

Machinery Health™ System

A6500-CC Com Card



Copyright

© 2024, Emerson. All rights reserved.

No part of this publication may be reproduced, transmitted, transcribed, stored in a retrieval system, or translated into any language in any form by any means without the written permission of Emerson.

Disclaimer

This manual is provided for informational purposes. EMERSON MAKES NO WARRANTY OF ANY KIND WITH REGARD TO THIS MATERIAL, INCLUDING, BUT NOT LIMITED TO, THE IMPLIED WARRANTIES OF MERCHANTABILITY AND FITNESS FOR A PARTICULAR PURPOSE. Emerson shall not be liable for errors, omissions, or inconsistencies that may be contained herein or for incidental or consequential damages in connection with the furnishing, performance, or use of this material. Information in this document is subject to change without notice and does not represent a commitment on the part of Emerson. The information in this manual is not all-inclusive and cannot cover all unique situations.

Patents

The product(s) described in this manual are covered under existing and pending patents.

Vermerk zur Installation der Messketten in explosionsgefährdeter Umgebung.



Soll die Messkette in explosionsgefährdeter Umgebung installiert werden, so ist auf die Einhaltung der in der Gebrauchsanweisung enthaltenen Installationshinweise zu achten. Sollten dabei sprachliche Schwierigkeiten auftreten, wenden Sie sich bitte an die Herstellerfirma, sie wird Ihnen eine Übersetzung der relevanten Artikel in der Landessprache des Verwendungslandes zukommen lassen.

Nota fuq l-installazzjoni tal-ktajjen tal-kejl f'ambjent esploziv



Jekk il-katina tal-kejl suppost li tigi installata f'ambjent esploziv, hu importanti li ssegwi l-istruzzjonijiet pertinenti tal-manwal. Jekk issib xi diffikultà bil-lingwa, jekk joghgbok ikkuntattja lill-manifattur biex tikseb traduzzjoni tal-paragrafi rilevanti fil-lingwa mehtiega.

Anmärkning beträffande installation av mätkedjorna i explosionsfarlig miljö.



Ska mätkedjan installeras i explosionsfarlig miljö, måste de anvisningar följas som ges i instruktionsboken beträffande installationen. Skulle därvid språkproblem uppstå, ber vi dig kontakta det tillverkande företaget som då kommer att sända dig en översättning av de relevanta artiklarna på användningslandets språk.

Opomba za namestitev merilne verige v eksplozivno ogroženem okolju



Èe se merilna veriga namešèa v eksplozivno ogroženem okolju, je potrebno upoštevati namestitvena opozorila, ki so v Navodilih za uporabo. Èe se pri tem pojavijo jezikovne težave, se posvetujte z izdelovalcem; poslali vam bodo prevod ustreznih èlankov v jeziku države, kjer se naprava uporablja.

Záznam k inštalácii meracích reťazcov vo výbušnom prostredí



Ak má byť merací reťazec inštalovaný vo výbušnom prostredí, treba dbať na dodržiavanie pokynov k inštalácii, uvedených v návode na použitie. V prípade, že by sa pritom vyskytli jazykové problémy, obráťte sa prosím na výrobcu, ktorý Vám zašle preklad relevantných èlánkov v jazyku Vašej krajiny.

Nota referente à instalação de cadeias de agrimensur em ambientes potencialmente explosivos



Caso a cadeia de agrimensur deva ser instalada em um ambiente potencialmente explosivo, é imprescindível observar e cumprir as indicações de instalação das instruções de serviço. Caso tenha dificuldades idiomáticas, queira entrar em contato com a firma produtora, esta poderá enviar-lhe uma tradução dos capítulos mais importantes no idioma do país onde o produto deverá ser empregado.

Wskazówka dotycząca instalacji łańcuchów mierniczych w otoczeniach zagrożonych eksplozją.



Jeżeli łańcuch mierniczy ma być zainstalowany w otoczeniu zagrożonym eksplozją, należy uwzględnić wskazówki dotyczące instalacji, które są zawarte w instrukcji obsługi. Jeżeli w trakcie lektury wystąpią jakiegokolwiek problemy związane ze zrozumieniem tekstu, prosimy zwrócić się do producenta, który chętnie wykona tłumaczenie wybranych części dokumentacji na język danego kraju.



Opmerking m.b.t. installatie van elektrische meet circuits in explosiegevaarlijke omgeving

Dient de installatie van elektrische meet circuits in een explosiegevaarlijke omgeving te geschieden, moet men toezien dat de in de gebruikshandleiding opgenomen installatieinstructies worden nageleefd. Bij taalkundige problemen gelieve contact op te nemen met de fabrikant, deze zal u vervolgens een vertaling in de taal van het gebruiksland doen toekomen.



Pastaba dėl matavimo grandinės įrengimo sprogimo atžvilgiu pavojingoje aplinkoje

Jei matavimo grandinė turi būti įrengta sprogimo atžvilgiu pavojingoje aplinkoje, privaloma laikytis vartotojo instrukcijoje pateiktų įrengimo nurodymų. Jei kiltų sunkumų dėl kalbos, prašome kreiptis į gamintojo įmonę, kuri pateiks Jums reikiamo skyriaus vertimą į vartotojo valstybės kalbą.



Nota sull'installazione delle catene per misurazione in ambienti a rischio di esplosioni

Nel caso in cui si debbano installare le catene per misurazione in ambienti a rischio di esplosioni, è necessario attenersi alle avvertenze per l'installazione contenute nelle istruzioni d'uso. Per difficoltà di carattere linguistico, rivolgetevi alla ditta produttrice. Quest'ultima Vi farà pervenire una traduzione degli articoli rilevanti nella lingua del paese d'impiego.



Megjegyzés a mérőláncok robbanásveszélyes környezetben történő szereléséhez.

Ha a mérőláncot robbanásveszélyes környezetben kell felszerelni, akkor ügyeljen a Használati útmutatóban közölt szerelési utasítások betartására. Amennyiben nyelvi nehézségek merülnek fel, szíveskedjen a gyártó céghez fordulni, amely elküldni Önnek a felhasználó ország nyelvére lefordított, erre vonatkozó cikket.



Remarque concernant l'installation des chaînes de mesure dans un environnement présentant un risque d'explosion

Si la chaîne de mesure doit être installée dans un environnement présentant un risque d'explosion, il est impératif de veiller à respecter les consignes d'installation contenues dans les instructions de service. S'il devait ce faisant surgir des problèmes linguistiques, veuillez vous adresser à la société fabricante: elle vous fera parvenir une traduction des articles significatifs dans la langue du pays de mise en oeuvre.



Huomautus mittausketjun asentamisesta räjähdysalttiissa ympäristössä

Jos mittausketju tulee asentaa räjähdysalttiissa ympäristössä, on käyttöohjeessa annettuja asennusohjeita noudatettava. Jos käyttöohjeessa käytetty kieli aiheuttaa ongelmia, kääntykää valmistajayrityksen puoleen. Se toimittaa käyttöönnne tarvittavat artikkelit käyttömaan viralliselle kielelle käännettynä.



Juhend mõõdukettide ülespanemiseks plahvatusohtlikus piirkonnas.

Kui panna üles mõõdukettid plahvatusohtlikkus piirkonnas, nii tuleb jälgida kasutusjuhendis sisalduvad instalationimärkmeid. Juhul kui tekkivad raskused keelega, siis pöörduge palun tootja poole. Tootja saadab emakeelse tõlge vastavalt artiklile ning maale.



Notas sobre la instalación de cadenas de medición en un entorno potencialmente explosivo.

Si ha de instalar la cadena de medición en un entorno potencialmente explosivo, deberá respetar las indicaciones sobre la instalación, contenidas en el manual de uso. Si surgieran dificultades lingüísticas, póngase en contacto con la empresa fabricante, que le facilitará una traducción del artículo en la lengua del país donde se emplee.



Note on the installation of the measuring chains in an explosive environment

If the measuring chain is supposed to be installed in an explosive environment, it is important to follow the pertinent installation instructions in the manual. Should you encounter difficulties with the language, please contact the manufacturer to obtain a translation of the relevant paragraphs into the language required.



Σημείωση για την εγκατάσταση αλισιδών μέτρησης σε περιβάλλον, στο οποίο υπάρχει κίνδυνος έκρηξης
Εάν η αλισουδα μέτρησης πρόκειται να εγκατασταθεί σε περιβάλλον, στο οποίο υπάρχει κίνδυνος έκρηξης, πρέπει να τηρηθούν οπωσδήποτε οι οδηγίες εγκατάστασης που περιλαμβάνονται στις οδηγίες Χρήσης. Εάν υπάρχουν γλωσσικές δυσκολίες καταούησης, παρακαλούμε να απευθυνθείτε στην κατασκευάστρια εταιρεία, η οποία θα φρουτίσει για την αποστολή μιας μετάφρασης των σχετικών άρθρων στη γλώσσα της Χώρας Χρήσης.



Info vedrørende installation af målekæderne i eksplosionstruede omgivelser

Hvis målekæden skal installeres i eksplosionstruede omgivelser, skal installationsanvisningerne i brugsanvisningen følges. Hvis der i denne forbindelse opstår sproglige problemer, bedes De henvende Dem til produktionsfirmaet, som så vil sørge for, at De modtager en oversættelse af den relevante artikel på Deres sprog.



Poznámka k instalaci měřicích řetězců v prostředí s nebezpečím výbuchu.

Když má být měřicí řetězec (sestavující z čidla a konvertoru) instalován v prostředí s nebezpečím výbuchu, tak je třeba respektovat instalační pokyny, které jsou součástí návodu k upotřebení. Kdyby při tom došlo k jazykovým potížím, tak prosíme kontaktujte výrobní firmu, která Vám relevantní článek zašle v jazyku krajiny použití.



Piezīme par mērišanas ķēžu instalēšanu sprādziena bīstamās zonās.

Ja mērišanas ķēde jāuzstāda sprādzienbīstamā zonā, ir jāievēro lietošanas instrukcijā dotie instalēšanas norādījumi. Ja rodas kādas valodas grūtības, lūdzu griezieties pie izgatavotāja firmas, kas Jums nosūtīs nozīmīgāko nodaļu tulkojumus lietotāja valsts valodā.

Emerson
epro GmbH
Jöbkesweg 3
48599 Gronau
Germany
T +49 2562 709 0
F +49 2562 709 401
www.Emerson.com

Contents

Chapter 1	General.....	7
	1.1 Using this manual.....	7
	1.2 Symbols.....	7
	1.3 Liability and guarantee.....	8
	1.4 Incoming goods inspection.....	8
	1.5 Technical support.....	8
	1.6 Storage and transport.....	9
	1.7 Disposal of the device.....	9
	1.8 China RoHS Compliance.....	9
	1.9 CCC Certification – AMS 6500 ATG.....	10
Chapter 2	Safety instructions.....	11
	2.1 Using the device.....	11
	2.2 Owner's responsibility.....	11
	2.3 Radio interference.....	12
	2.4 ESD safety.....	12
Chapter 3	Application and design.....	13
	3.1 Application.....	13
	3.2 Design.....	13
Chapter 4	Installation.....	17
	4.1 Ethernet and USB connection.....	17
	4.2 Micro SD card.....	18
	4.2.1 Install a micro SD card.....	19
	4.2.2 Replace a micro SD card.....	19
Chapter 5	Hazardous location installation	20
Chapter 6	Configuration.....	21
	6.1 General configuration procedure.....	21
	6.1.1 Offline configuration overview.....	21
	6.1.2 Online configuration overview.....	22
	6.2 Start of an offline card configuration.....	22
	6.3 Start of an online card configuration.....	23
	6.4 Configuration of an already existing card.....	24
	6.5 Configuration editor and parameters.....	24
	6.5.1 Ribbon command bar.....	25
	6.5.2 Basic.....	29
	6.5.3 LAN.....	30
	6.5.4 Auto discovery.....	31
	6.5.5 Configuration interface.....	32

	6.5.6 Mobile app interface.....	33
	6.6 Send and Reload a configuration.....	34
	6.6.1 Send a configuration.....	34
	6.6.2 Reload a configuration.....	35
Chapter 7	Redundancy.....	36
	7.1 Configuration.....	38
	7.2 Manual change of active/passive state.....	40
Chapter 8	Online View.....	43
	8.1 Overview.....	44
	8.2 Details.....	46
	8.3 Online commands.....	47
Chapter 9	Functions and applications.....	49
	9.1 Single Com Card communication.....	49
	9.2 Redundant Com Card communication.....	50
	9.2.1 Modbus RTU - Both cards with an identical device address.....	50
	9.2.2 Modbus RTU - Com Cards with unique device addresses.....	52
	9.2.3 Modbus over TCP/IP - both cards within the same LAN.....	54
	9.2.4 Modbus over TCP/IP - two separate LANs.....	56
Chapter 10	Maintenance.....	59
Chapter 11	Replace a Com Card.....	60
Chapter 12	Technical data.....	61
	12.1 Power supply.....	61
	12.2 Interfaces.....	61
	12.3 Mechanical design and environmental conditions.....	62
Chapter 13	Certificates.....	65
Appendix A	Card related system events.....	76
Index	79

1 General

1.1 Using this manual

This manual contains information concerning the use of the device.

Read the operating manual completely prior to starting installation and operating the device. Comply with all safety instructions.

This operating manual applies for the A6500-CC Com Cards with hardware revisions and software versions listed in [Table 1-1](#).

Table 1-1: Hardware and software revisions

Hardware revision	Firmware version	AMS Machine Studio version
04, 05, 06, 07, and 08 ¹	3.3	3.6

¹ See type plate for revision level.

The redundancy function is available for A6500-CC Com Cards with firmware version 1.2.0 and higher.

Include the operating manual when transferring the device to third parties.

Note

When requesting technical support, please indicate type and serial number from the type plate.

[Table 1-2](#) shows a list of documents that are referred to in this operating manual.

Table 1-2: Referenced documents

MHM-97873	Operating Manual A6500-UM Universal Measurement Card
MHM-97874	Operating Manual A6500-TP Temperature Process Card
MHM-97876	Operating Manual A6500-RC Relay Card
MHM-97877	Operating Manual A6500-xR System Racks
MHM-97879	Operating Manual AMS Machine Studio - General Function

1.2 Symbols

Note



This symbol marks passages that contain important information.

CAUTION

This symbol marks operations that can lead to malfunctions or faulty measurements, but will not damage the device.

⚠ DANGER

A danger indicates actions that can lead to property damage or personal injury.

	According to IEC 61010, this symbol means that this device must be operated with DC voltage.
	According to IEC 61010, this symbol means that the documentation of the device must completely be read and understood before installing and commissioning of the device. Observe all safety related instructions in this document.

1.3 Liability and guarantee

Emerson is not liable for damages that occur due to improper use. Proper use also includes the knowledge of, and compliance with, this document.

Customer changes to the device that have not been expressly approved by Emerson will result in the loss of guarantee.

Due to continuous research and further development, Emerson reserves the right to change technical specifications without notice.

1.4 Incoming goods inspection

Check the content of the shipment to ensure that it is complete; visibly inspect the goods to determine if the device has been damaged during transport. The following parts are included in the scope of delivery and must be contained in the shipment.

- Com Card
- Operating manual

If the contents are incomplete, or if you observe any defects, file a complaint with the carrier immediately. Inform the responsible Emerson sales organization so your device can be replaced. In this case, attach a tag with customer name and the observed defect.

1.5 Technical support

You may need to ship this product for return, replacement, or repair to an Emerson Product Service Center. Before shipping this product, contact Emerson Product Support to obtain a Return Materials Authorization (RMA) number and receive additional instructions.

Product Support

Emerson provides a variety of ways to reach your Product Support team to get the answers you need when you need them:

Phone Toll free 1 800 833 8314 (U.S. and Canada)
+1 512 832 3774 (Latin America)

+63 2 8702 1111 (Asia Pacific, Europe, and Middle East)

Email Guardian.GSC@Emerson.com

Web <http://www.emerson.com/en-us/contact-us>

To search for documentation, visit <http://www.emerson.com>.

To view toll free numbers for specific countries, visit <http://www.emerson.com/technicalsupport>.

Note

If the equipment has been exposed to a hazardous substance, a Material Safety Data Sheet (MSDS) must be included with the returned materials. An MSDS is required by law to be available to people exposed to specific hazardous substances.

1.6 Storage and transport

Store and transport the device only in its original packaging. Technical data specifies the environmental conditions for storage and transport.

Related information

[Technical data](#)

[Power supply](#)

[Interfaces](#)

[Mechanical design and environmental conditions](#)

1.7 Disposal of the device

Provided that no repurchase or disposal agreement exists, recycle the following components at appropriate facilities:

- Recyclable metal
- Plastic elements

Sort the remaining components for disposal, based on their condition. National laws or provisions on waste disposal and protection of the environment apply.

Note

Environmental hazards! Electrical waste and electronic components are subject to treatment as special waste and may only be disposed by approved specialized companies.

1.8 China RoHS Compliance

Our products manufactured later than June 30, 2016, and those which are sold in the People's Republic of China are marked with one of the following two logos to indicate the Environmental Friendly Use Period in which it can be used safely under normal operating conditions.

Products that do not have the following marking were either manufactured before June 30, 2026, or are not electrical equipment products (EEP).



Circling arrow symbol with "e": The product contains no hazardous substances over the Maximum Concentration Value and it has an indefinite Environmental Friendly Use Period.



Circling arrow symbol with a number: This product contains certain hazardous substances over the Maximum Concentration Value and it can be used safely under normal operating conditions for the number of years indicated in the symbol. The names and contents of hazardous substances can be found in chapter "Certificates".

1.9 CCC Certification – AMS 6500 ATG

With the announcement of the Chinese market regulation authority SAMR (State Administration for Market Regulation), a Compulsory Product Certification (CCC certification) is mandatory for many explosion protection products. This explosion proof ("Ex") product complies to the CCC obligation and is certified (certification number: 2020322304002386).



This China Compulsory Certificate mark (CCC), is a compulsory safety mark for many products imported, sold, or used in the Chinese market and indicates that the product is certified in accordance to GB/T 3836.1-2021, GB/T 3836.3-2021, and GB/T 3836.8-2021. If the product label is too small to contain the CCC certification mark, it is sufficient to have the mark printed on the minimum package and in the attached document.

2 Safety instructions

To ensure safe operation, carefully follow all the instructions in this manual.

The correct and safe use of this device requires that operating and service personnel both understand and comply with general safety guidelines and observe the special safety comments listed in this manual. Where necessary, safety-sensitive points on the device are marked.

⚠ DANGER

Because the device is electrical equipment, only specially trained and authorized personnel may commission, service, and maintain this equipment.

2.1 Using the device

Install and use the device as specified in this document.

If the device is used in a manner not specified by the manufacturer, the functions and protection provided by the device may be impaired.

2.2 Owner's responsibility

If there is a reason to suspect that hazard-free operation, and thus, adequate machine protection is no longer possible, take the device out of operation and safeguard it from unintentional operation. This is the case:

- if the device shows visible damage.
- if the device no longer works.
- after any kind of overload that has exceeded the permissible limits (see technical data of the device for permissible limits).

⚠ DANGER

If device tests have to be completed during operation or if the device has to be replaced or decommissioned, it will impair the machine protection and may cause the machine to shut down. Make sure to deactivate machine protection before starting such work, and reactivate it after work has been completed.

Related information

[Technical data](#)

[Power supply](#)

[Interfaces](#)

[Mechanical design and environmental conditions](#)

2.3 Radio interference

The device is carefully shielded and tested to be technically immune to radio interference and complies with current standards. However, if you operate this device together with other peripheral devices that are not properly shielded against radio interference, disturbances and radio interferences may occur.

2.4 ESD safety

DANGER

Internal components can be damaged or destroyed due to electrostatic discharge (ESD) during the handling of the device.

Take suitable precautions before handling the device to prevent electrostatic discharges through the electronics. Such measures might include, for example, wearing an ESD bracelet. Transport and storage of electronic components may only be made in ESD-safe packaging.

Handle the device with particular care during dry meteorological conditions with relative humidity below 30% as electrostatic discharges can occur more frequently.

3 Application and design

3.1 Application

The A6500-CC Com Card is a component of the AMS 6500 ATG system and mandatory for communication with all cards of the system as the A6500-UM Universal Measuring Card, the A6500-TP Temperature Process Card, and the A6500-RC Relay Card. The Com Card is required for the configuration of the protection cards. It servers also the cyclical polling of card data. The captured data are output by Modbus over TCP, Modbus RTU, and/or through the OPC UA communication. You can build up a redundant data communication with a second A6500-CC Com Card.

The card is designed for use in the communication slots (CD13 and CD14) of the A6500-xR System Racks. A second System Rack can be connected to the COM Card. See operating manual A6500-xR System Racks for further information.

3.2 Design

The Com Card is designed as standard Euro board (100 mm X 160 mm) and has an anodized front plate of 4TE (approximately 20 mm) width. The card is designed for use in A6500-xR System Racks. The electric connection is made by a 30-pole connector (DIN41612 / IEC60603-2 Design c/3).

The USB interface, the Ethernet interface, and the Modbus RTU interface are galvanically isolated.

Figure 3-1 shows the Com Card.

Figure 3-1: Side view

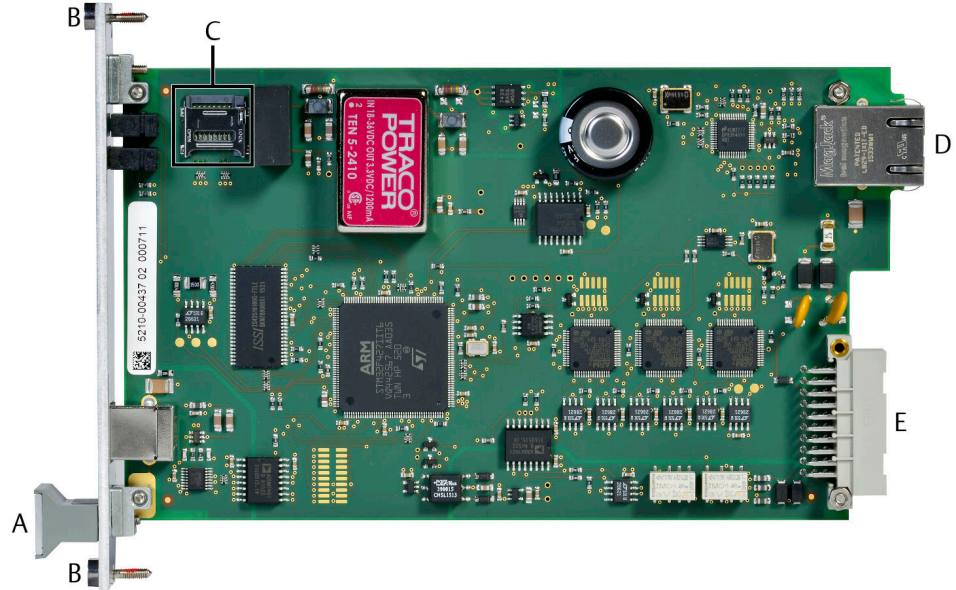

- A. Handle - for pulling the monitor from the rack; labeled with the serial number on a small sticker.
- B. Mounting screws
- C. Slot for micro SD card (use only Emerson authorized micro SD cards)
- D. RJ45 Ethernet connector
- E. Connector

The type plate with designation (PN), serial number (SN), and hardware revision (Rev.) is on the black cover.

Figure 3-2 shows the front plate elements of a Com Card.

Figure 3-2: Front view



- A. Handle
- B. Mounting screws
- C. green OK LED: Card power and status indication (see [Table 3-1](#))
- D. yellow Data LED: Data traffic (see [Table 3-1](#))
- E. USB connector

Table 3-1: Blinking pattern LEDs

Event	Blinking pattern
No power supply	Both LEDs off.
Start up phase	Alternate flashing of Data LED and OK LED (1,25 Hz) for approximately 5 seconds.
Phase before card restart	Data LED flashes according to the data traffic, OK LED flashes with 5Hz for approximately 5 seconds between receiving command and restart.
Temperature failure	Data LED flashes according to the data traffic, OK LED off.

Table 3-1: Blinking pattern LEDs (continued)

Event	Blinking pattern
Temperature warning	Data LED flashes according to the data traffic, OK LED flashes with approximately 0.8 Hz.
Default configuration	Data LED flashes according to the data traffic, OK LED is 0,5 seconds on and 2 seconds off (see Overview).
Configuration not in sync	Data LED flashes according to the data traffic, OK LED is 0,5 seconds on and 2 seconds off (see Overview).

4 Installation

The Com Card requires an installed and wired A6500-xR System Rack. See rack manual for further installation details. An A6500-xR System Rack (A6500-SR or A6500-RR) is equipped with two Com Card slots. Install a single Com Card either into the left slot or into the right slot. Emerson recommends to use the left slot (CD13) for single Com Card installations and for the primary Com Card in redundant systems the right slot (CD14).

Note

When moving the Com Card from one Com Card slot to another wait 15 seconds between removing the card and pushing it into the other slot. Otherwise AMS Machine Studio cannot recognize this change.

Procedure

1. Check whether the wiring of the slot meets the requirements.
 - a) Check the Modbus RTU wiring if Modbus RTU communication is required.
 - b) Check the connection of the 9-pole bus line linking cable if the bus lines of a second A6500-xR should be connected to the Com Card slot.
2. Push the Com Card firmly but gently into the slot.

Note

At single card communication (no redundant communication), Emerson recommends to install the Com Card into the left slot (CD13).

3. Hand-tight both screws at the front plate to secure the card.
4. Plug the Ethernet cable into the RJ45 socket if the card shall be integrated into a network.
5. Repeat these steps if a second Com Card for building a redundant communication shall be installed.

4.1 Ethernet and USB connection

The A6500-CC Com Card has an Ethernet interface for connecting the card to an Ethernet network. This Ethernet interface and the USB interface are for the communication with the AMS Machine Studio configuration software. The Ethernet interface also serves the Modbus over TCP/IP and OPC UA communication.

The following communication tasks are available with the USB and Ethernet interface:

- Reading measuring data from the protection cards by AMS Machine Studio.
- Reading status data from the protection cards by AMS Machine Studio.
- Configuration of the protection cards by AMS Machine Studio.
- Sending commands by AMS Machine Studio.

Note

The USB interface does not provide Modbus or OPC UA data.

Time data cannot be read through the USB interface. That means time waveforms and frequency spectrums of the A6500-UM cards cannot be displayed if the card is connected through the USB interface.

Ethernet

The Ethernet interface is a 10/100 MBit interface with a RJ 45 socket. Use CAT5 Patch cables or Cross over cables for connection. The maximal cable length is 100 m.

USB

The USB 2.0 interface has a type B socket. The maximal cable length is 5 m. It is not necessary to install a driver for the USB interface. The required driver is already part of the operating system Microsoft Windows 10.

Note

Use the USB interface if the Com Card is not connected to an Ethernet network or the Laptop/ PC used has no access to the network.

4.2 Micro SD card

The A6500-CC Com Card is equipped with a slot for a micro SD card (see [Figure 3-1](#) for location). A micro SD card is required for storing of events and for ATG systems with data collection function. If a Com Card is not yet equipped with a micro SD card upgrade it with an Emerson authorized micro SD card as described in [Install a micro SD card](#). The data collection function is available for Com Cards with firmware version 2.x.xx and later versions. The storage of events is available for Com Cards with firmware version 3.x and later. Follow the steps in [Replace a micro SD card](#) to replace a micro SD card. This could be necessary in case of a defect or after five years of operation.

[Figure 4-1](#) shows the micro SD card slot.

Figure 4-1: Micro SD card slot

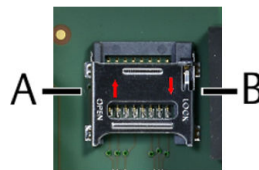

- A. Arrow up: unlock micro SD card slot
 - B. Arrow down: lock micro SD card slot
-

Note

Use only micro SD cards authorized by Emerson.

Emerson recommends replacing the micro SD card after five years of operation.

4.2.1 Install a micro SD card

Procedure

1. Slide the cover (silver colored part) of the slot in direction open (see [Figure 4-1](#)) to unlock it.
2. Open the cover.
3. Place the micro SD card with contacts downwards into the slot. The card fits only in one direction.
4. Close the cover.
5. Slide the cover in direction lock (see [Figure 4-1](#)) to lock the cover.

4.2.2 Replace a micro SD card

Procedure

1. Slide the cover (silver colored part) of the slot in direction open (see [Figure 4-1](#)) to unlock it.
2. Open the cover.
3. Remove the old micro SD card.
4. Place the new micro SD card with contacts downwards into the slot. The card fits only in one direction.
5. Close the cover.
6. Slide the cover in direction lock (see [Figure 4-1](#)) to lock the cover.

5 Hazardous location installation

The ex-approval of the A6500-CC Com Card is only valid if the Com Card is installed in an A6500-xR System Rack. See chapter "Hazardous location installation" of the A6500-xR System Racks operating manual (MHM-97877) for details.

6 Configuration

6.1 General configuration procedure

The configuration can be performed offline that means without connection to the card or online, with a connection to the card. In any case, the configuration has to be loaded into the card to become active.

Prerequisites

- USB cable with Type-A and Type-B plug or Ethernet cable
- AMS Machine Studio (configuration software)
- PC or laptop with Microsoft Windows 10

Note

At the first configuration of an AMS 6500 ATG system use the USB interface to set the IP address for the network connection. The default IP address of a new A6500-CC Com Card installed in slot 13 is **192.168.1.100** and **192.168.1.101** for a new A6500-CC in slot 14.

6.1.1 Offline configuration overview

Procedure

1. Start AMS Machine Studio.
2. Enter configuration parameter according to the communication requirements.
3. Save the configuration.
When there is a connection to the system, you can load the saved configuration file to the card (see [Send a saved configuration file to the Com Card](#)).

Send a saved configuration file to the Com Card

Procedure

1. Switch on the power supply of the system if not already done.
2. Connect the laptop to the Com Card of the system by using the USB or Ethernet connection.
3. Start the AMS Machine Studio.
4. Select the card to be configured and click **Configure**.
5. Open the saved configuration file (window **File**, menu item **Open**).
6. Send the configuration to the card.
7. Close AMS Machine Studio and disconnect the connection to the Com Card.
After these steps, the Com Card is ready for operation.

6.1.2 Online configuration overview

Procedure

1. Switch on the power supply of the system if not already done.
2. Connect the laptop to the Com Card of the system by using the UBS or Ethernet connection.
3. Start AMS Machine Studio.
4. Select the card to be configured and click **Configure**.
5. Enter the configuration parameters according to the communication requirements (IP address, and so on).
6. Send the configuration to the card.
7. Save the configuration.
8. Close the AMS Machine Studio and disconnect the connection to the Com Card.
After these steps, the Com Card is ready for operation.

6.2 Start of an offline card configuration

Procedure

1. Select **Workspace** in the left part of the **Home** view then click **Item** (see [Figure 6-1](#)).

Figure 6-1: Start new device configuration

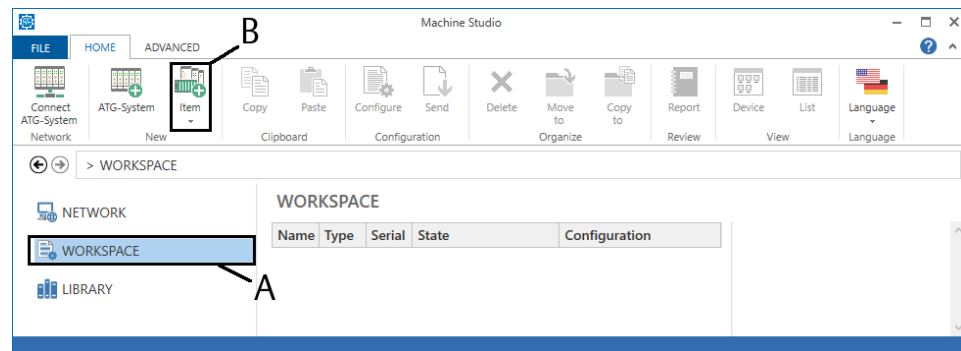

- A. Workspace
- B. Button Item

2. Select A6500-CC from the device list (see [Figure 6-2](#)).

Figure 6-2: Card selection

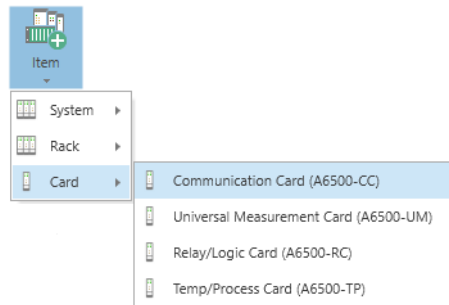

The Com Card is added to the list below **Workspace**.

3. Select **A6500-CC** from the Workspace list and click **Configure** (see [Figure 6-3](#)).

Figure 6-3: Configure

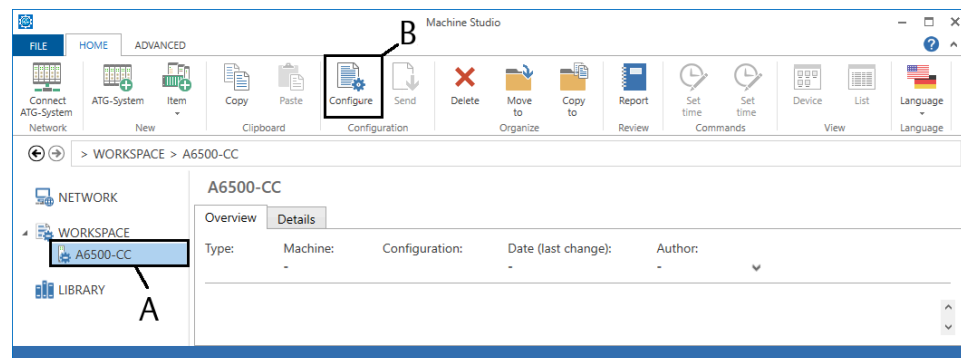

- A. New A6500-CC card
- B. Button **Configure** to open the configuration editor.

The window for the selection of the measuring application opens if an unconfigured card has been selected, otherwise the editor with configuration of the card directly opens.

4. Select an application. This step and the next step can be skipped if the editor has been directly opened.
5. Click **Create Configuration** to open the configuration.
See [Configuration editor and parameters](#) for parameter description and settings, depending on the selected measurement application.

6.3 Start of an online card configuration

Procedure

1. Select the A6500-CC card from the Network list in the left part of the **Home** view, then click **Configure** (see [Figure 6-4](#)).

Figure 6-4: Select a Com Card for online configuration

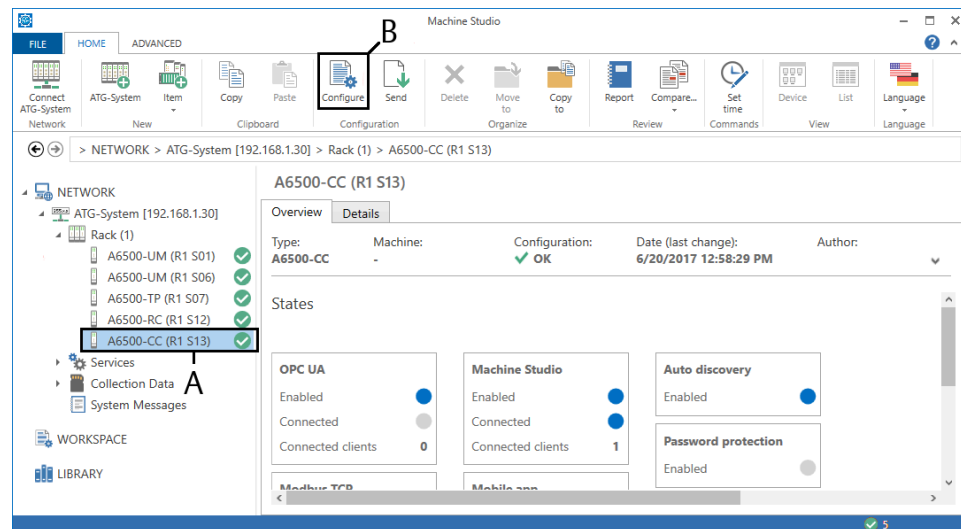

A. Selected A6500-CC card.

B. Button **Configure** for opening the configuration editor.

The window for the selection of the measuring application opens if an unconfigured card has been selected, otherwise the editor with the configuration opens.

2. Select an application.
3. Click **Create Configuration** to open the configuration.
4. Check the configuration and modify it in accordance to the communication requirements. See [Configuration editor and parameters](#) for parameter description and settings.

6.4 Configuration of an already existing card

Procedure

1. Select the card to be reconfigured from the **Network** list.
2. Click **Configure** to open the configuration window.
3. Make the changes to the configuration.
4. Send the configuration to the card (see [Send a configuration](#)).

6.5 Configuration editor and parameters

Figure 6-5 shows an overview of the general configuration editor **Configuration**.

Figure 6-5: Configuration editor

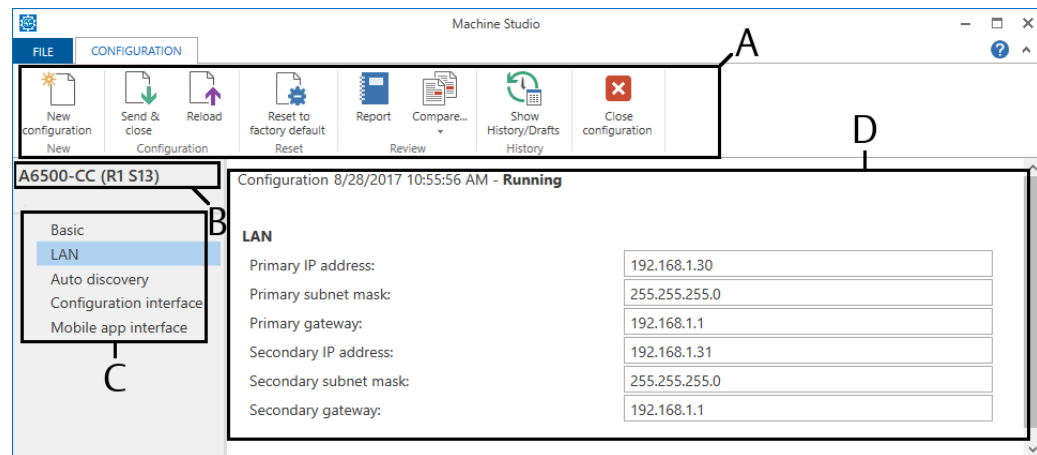

- A. Ribbon command bar
- B. Card name and position within the rack (only visible at connected racks, for example: R1 = Rack 1; S13 = Slot 13)
- C. List of configuration pages
- D. Configuration page

6.5.1 Ribbon command bar

New configuration

Figure 6-6: Button "New configuration"

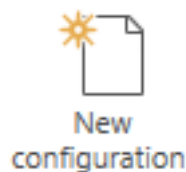

Click **New configuration** to start a new configuration with default parameters.

Send & close

Figure 6-7: Button "Send & close"



Click **Send & close** to send the configuration to the Com Card. The configuration editor automatically closes after the sending process. This command requires an online connection to the card.

Reload

Figure 6-8: Button "Reload"



Click **Reload** to reload the configuration from the Com Card to the configuration editor. Any configuration changes you made in AMS Machine Studio will be reset to the existing configuration from the Com Card.

Reset to factory default

Figure 6-9: Button "Reset to factory default"

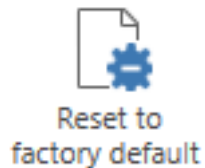

Click **Reset to factory default** to reset the connected Com Card to the default parameter settings. A reset card is marked with the "No configuration" sign in the Online View (see [Figure 6-10](#)).

Figure 6-10: No configuration sign



This command requires an online connection to the card.

⚠ CAUTION

The preset configuration on the card will be deleted and replaced by the default configuration.

Compare

Figure 6-11: Button "Compare"



Click **Compare** to show differences between the configuration on the card and in the memory of the used Laptop or PC.

Report

Figure 6-12: Button "Report"



Click **Report** to open the report viewer. This report shows all configured parameters and some additional information as, for example, serial number and user information. This report can be exported to different formats as PDF, XPS, and Microsoft Excel or can be printed.

The logos in the header of the report can be changed.

1. Close the configuration editor.
2. Click tab **File** and then **Settings**.
The window **Settings** opens (see [Figure 6-13](#)).
3. Click the buttons with the dotted line within the **Report settings** area to browse for logos.
Logos with file format "png" or "jpg" can be selected.
4. Click **OK** to confirm your settings.
The window closes.
5. Open the configuration editor and go back to the report.
Now the report contains the selected logos.

Figure 6-13: General settings

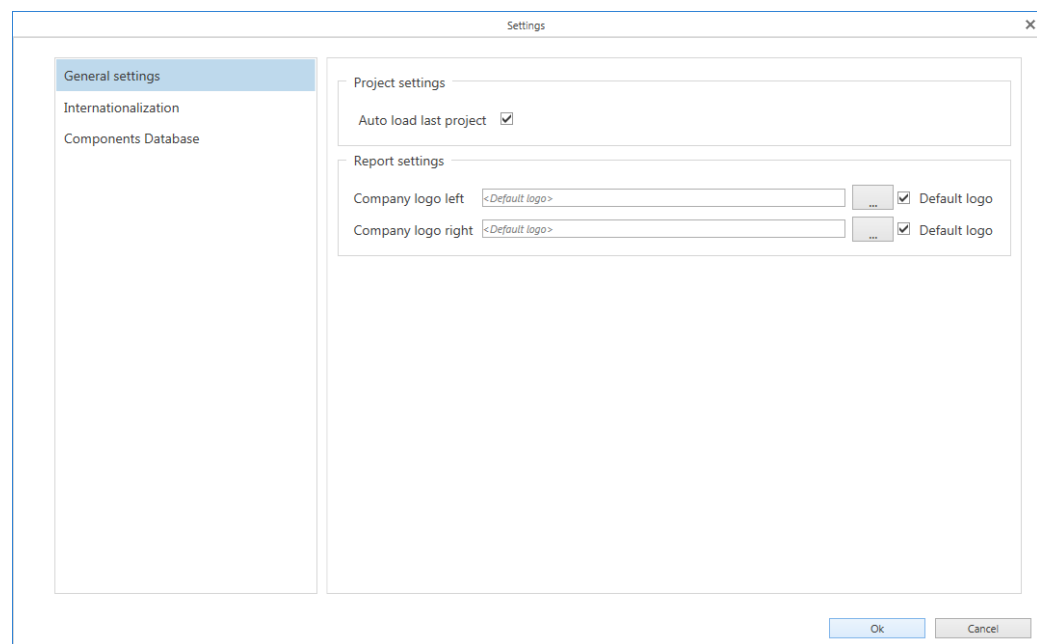

Show History/Drafts

Figure 6-14: Button "Show History/Drafts"

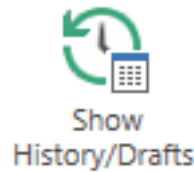

Click **Show History/Drafts** to open the History (see Figure 6-15).

Figure 6-15: History

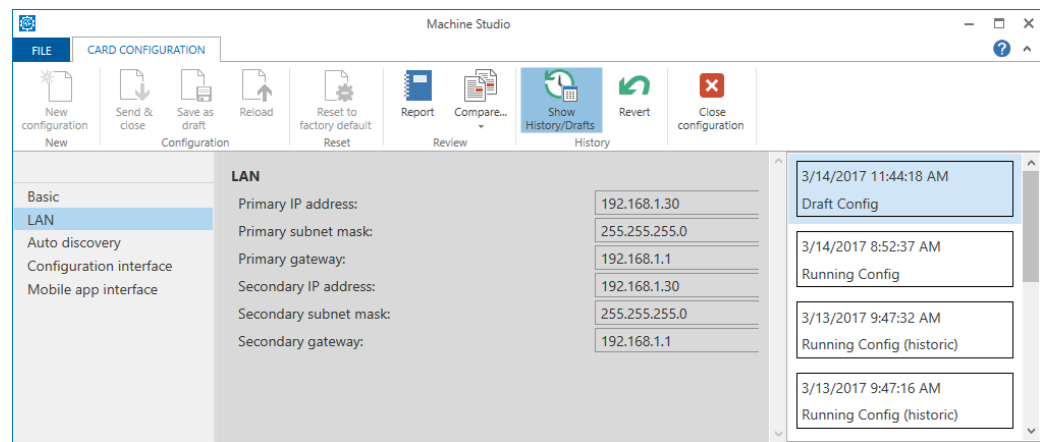

The right part of Figure 6-15 shows the configuration history. The individual files are marked with date and time and type:

- **Draft Config**
A saved preliminary configuration file which has not yet been sent to the card.
- **Running Config**
This configuration file is running on the connected card.
- **Running Config (historic)**
An old configuration file which was running in the past.

The editor area is grayed out. You can see the parameters of the historic files but you can not change them. Parameters can only be changed in the editor. To copy a historic configuration to the editor:

1. Select a draft or historic file from the list.
The parameters of the selected file are displayed in the grayed out editor area.
2. Click **Revert** (see Figure 6-16). The selected file is copied to the editor and the history window is closed. Click **Show History/Drafts** again, if you want to leave the history without any file copying.

Figure 6-16: Button "Revert"



Close configuration

Figure 6-17: Button "Close configuration"



Click **Close configuration** to leave the editor. Changes are automatically saved as a draft configuration. A saved draft can be opened in the history view.

6.5.2 Basic

Enter general machine and plant information and make basic settings for the AMS 6500 ATG system (see [Figure 6-18](#)).

Figure 6-18: Basic

ComCard (R1 S13)		Configuration 3/21/2023 2:01:15 PM - Running
<ul style="list-style-type: none"> Basic LAN Auto discovery Configuration interface Mobile app interface 	Basic	
	System name:	My ATG
	Card name:	ComCard
	Machine:	
	Area:	
	Plant:	
	User:	
	Date (last change):	3/21/2023 2:01:15 PM
	Configuration version:	3.5.0-dev38-rc.2
	Allow reboot by Modbus/OPC UA:	<input checked="" type="checkbox"/>

Rack name	Enter the name or a short description of the Rack.
Card name	Enter the card name or short description of the measurement.
Machine	Enter the machine designation.
Area	Enter a name or short description of the area where the machine is located.
Plant	Enter the plant/factory name.
User	The name of the user who made the last configuration is displayed. The user name of the login data of the operation

	system is used for this automatic entry. It is not possible to change the content of this field.
Date (last change)	The date and time of the last card configuration is displayed. Time and date of the configuration PC is used. It is not possible to change the content of this field.
Configuration version	The version of AMS Machine Studio used to configure the card is displayed.
Allow reboot by Modbus/OPC UA	Check this box to allow the reboot of the A6500-CC through Modbus or OPC UA communication. See Manual change of active/passive state .

6.5.3 LAN

The LAN section contains the IP addresses of the primary and secondary card (see [Figure 6-19](#)). These addresses are generally provided by the local network administrators.

Note

The configuration requires an IP address for the secondary card even if only the primary card is used. If only one Com Card is used enter the same IP address, subnet mask, and gateway for the primary and secondary card.

Figure 6-19: LAN

A6500-CC (R1 S13)		Configuration 3/14/2017 11:44:18 AM - Draft*
<ul style="list-style-type: none"> Basic LAN Auto discovery Configuration interface Mobile app interface 	LAN	
	Primary IP address:	192.168.1.30
	Primary subnet mask:	255.255.255.0
	Primary gateway:	192.168.1.1
	Secondary IP address:	192.168.1.30
	Secondary subnet mask:	255.255.255.0
	Secondary gateway:	192.168.1.1

Primary IP address

Enter here the IP address (IP4 standard) for the Com Card installed in the left communication card slot (CD13).

Primary subnet mask

Enter here the subnet mask for the Com Card installed in the left communication card slot (CD13).

Primary gateway

Enter here the gateway address for the Com Card installed in the left communication card slot (CD13).

Secondary IP address

Enter here the IP address (IP4 standard) for the Com Card installed in the right communication card slot (CD14).

Secondary subnet mask

Enter here the subnet mask for the Com Card installed in the right communication card slot (CD14).

Secondary gateway

Enter here the gateway address for the Com Card installed in the right communication card slot (CD14).

Note

The sending of a configuration with changed IP addresses causes a disconnect of all connections to AMS Machine Studio. Afterwards the connections are automatically reestablished.

6.5.4 Auto discovery

The **Auto discovery** section allows you to enable or disable the auto discovery function (see [Figure 6-20](#)).

Figure 6-20: Auto discovery

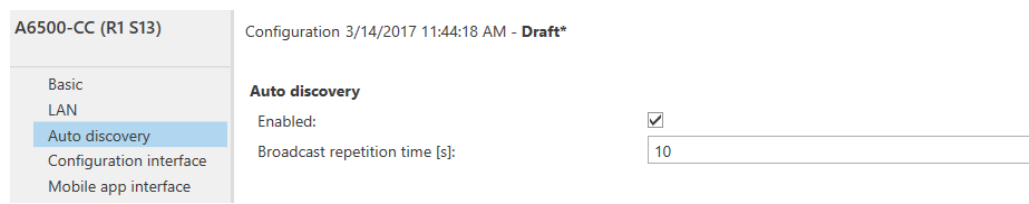

Enable

Check this box to enable auto discovery. This function sends out a recurring broadcast through the connected network. AMS Machine Studio installed on a PC/Laptop within the same network will receive this command and add the discovered host to the TCP/IP connection list (see [Figure 6-22](#)). Open this window by clicking the connect button in the ribbon command bar (see [Figure 6-21](#)).

Figure 6-21: Connect button



Figure 6-22: List of discovered hosts

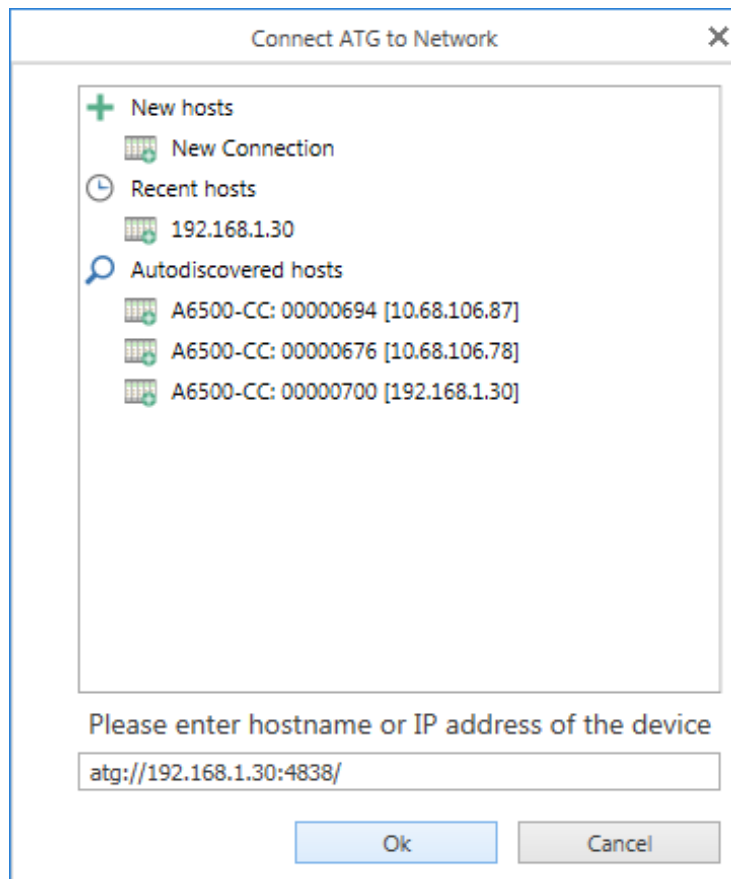

Broadcast repetition time [s]

Enter here the repetition time for the broadcast.

6.5.5 Configuration interface

Configure here the configuration interface (see [Figure 6-23](#)). Define a configuration interface if you want to allow additional interfaces to change the configuration settings.

Up to three AMS Machine Studios can simultaneously connect to the configuration interface.

Figure 6-23: Configuration interface settings

A6500-CC (R1 S13)		Configuration 3/14/2017 11:44:18 AM - Draft*
<ul style="list-style-type: none"> Basic LAN Auto discovery Configuration interface Mobile app interface 	Configuration interface	
	Enabled:	<input checked="" type="checkbox"/>
	Port:	<input type="text" value="4838"/>
	Use IP white list:	<input type="checkbox"/>
	IP address 1:	<input type="text" value="0.0.0.0"/>
	IP address 2:	<input type="text" value="0.0.0.0"/>
IP address 3:	<input type="text" value="0.0.0.0"/>	
IP address 4:	<input type="text" value="0.0.0.0"/>	
IP address 5:	<input type="text" value="0.0.0.0"/>	

Enable

Check this box to enable configuration through the TCP/IP interface.

Port

Enter here the TCP port for the network communication. Ensure that the port entered is unique and not used by another AMS 6500 ATG interface.

Note

Sending of a configuration with a changed port causes a disconnect of all connections to AMS Machine Studio. Afterward the connections are automatically reestablished.

Use IP white list

Check this box to enable the IP white list.

IP address 1 to IP address 5

Enter here up to five IP addresses of devices which are allowed to communicate with the configuration interface.

6.5.6 Mobile app interface

Configure here the interface to the mobile app (see [Figure 6-24](#)).

Up to five mobile devices can simultaneously connect to the app interface. The interface supports the reading of data. Use AMS Machine Studio to configure AMS 6500 ATG.

Figure 6-24: Mobile App Interface settings

A6500-CC (R1 S13)		Configuration 3/14/2017 11:44:18 AM - Draft*
<ul style="list-style-type: none"> Basic LAN Auto discovery Configuration interface Mobile app interface 	Mobile app interface	
	Enabled:	<input checked="" type="checkbox"/>
	Port:	<input type="text" value="4839"/>
	Use IP white list:	<input type="checkbox"/>
	IP address 1:	<input type="text" value="0.0.0.0"/>
	IP address 2:	<input type="text" value="0.0.0.0"/>
IP address 3:	<input type="text" value="0.0.0.0"/>	
IP address 4:	<input type="text" value="0.0.0.0"/>	
IP address 5:	<input type="text" value="0.0.0.0"/>	

Enabled

Check this box to allow mobile devices the connection to the Com Card.

Port

Enter here the port for the communication. Ensure that the port entered is unique and not used by another AMS 6500 ATG interface.

Note

Sending of a configuration with a changed port causes a disconnect to connected mobile devices. Afterward the connections are automatically reestablished.

Use IP white list

Check this box to enable the IP white list.

IP address 1 to IP address 5

Enter here up to five IP addresses of mobile devices which are allowed to communicate with the Com Card.

6.6 Send and Reload a configuration

6.6.1 Send a configuration

CAUTION

Connections to external devices may be interrupted when sending configurations.

Note

Modbus requests are answered with **Server Device Busy (0x06)** when sending a configuration.

Procedure

1. Ensure that there is an online connection between the Com Card and AMS Machine Studio running on a PC or laptop.

AMS Machine Studio will automatically establish an online connection to the cards of the AMS 6500 ATG system as soon as there is a physical connection through the USB port of the A6500-CC Com Card of the system. Click **Connect ATG** on the ribbon command bar of **Home** to establish a connection at TCP/IP connection.

2. Click **Send & close** in the ribbon command bar to send the configuration to the card.

The confirmation dialog opens:

Figure 6-25: Confirmation – overwrite configuration

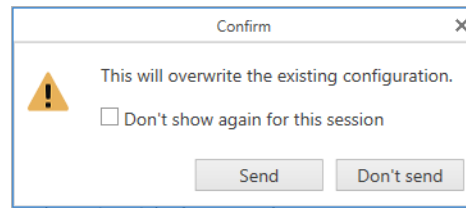

Click **Send** to overwrite the existing configuration. Connections to external devices may be interrupted when sending the configuration.

The configuration editor automatically closes after the sending process.

A successful sent configuration will be indicated by a message in the upper right corner of the software window. This message window will automatically disappear. Otherwise close it by clicking on the cross.

The card is ready to use when the "OK" LED on the card front shows a green steady light.

6.6.2 Reload a configuration

Once an online connection has been established, the configuration of all cards of a AMS 6500 ATG system are automatically loaded to AMS Machine Studio. Click **Reload** in the ribbon command bar if the card's configuration must be loaded again.

7 Redundancy

Note

The redundancy function is available for A6500-CC Com Cards with firmware version 1.2.0 and higher.

Ensure that both A6500-CC Com Cards used for the redundancy have the same firmware version installed.

Install two A6500-CC Com Cards to establish a system with redundant communication. See [Installation](#) for installation details.

[Figure 7-1](#) shows the structure of an redundant communication setup.

Figure 7-1: Redundancy

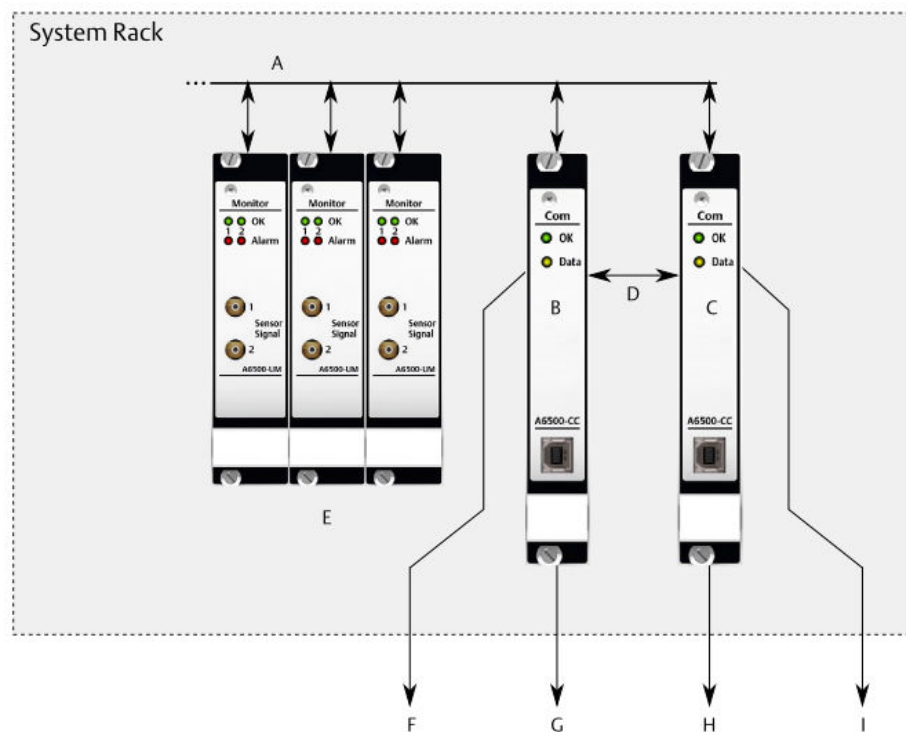

- A. System Rack Bus
- B. Primary Master (Slot 13)
- C. Secondary Master (Slot 14)
- D. Com Card link
- E. Cards
- F. Primary Master: Modbus over TCP/IP and OPC UA
- G. Primary Master: Modbus RTU
- H. Secondary Master: Modbus over TCP/IP and OPC UA
- I. Secondary Master: Modbus RTU

- The left Com Card slot (slot 13) is the primary Com Card slot. The right Com Card slot (slot 14) is the secondary Com Card slot.
- Both Com Cards are linked through the backplane.
- One Com Card communicates through the backplane with the installed cards (active on the bus). The other COM Card is passive.
- The active Com Card collects the data and copies it to the passive card.

Note

Collection data is not copied from the active to the passive card.

- Both Com Cards can provide data, Modbus over TCP/IP, Modbus RTU, and/or OPC UA.
- Configuration of the protection cards is possible through both cards.

Figure 7-2 shows an example scenario with a defect Com Card in slot 13 (primary master slot). In this scenario, the primary Com Card is no longer active on the System Rack bus. The secondary Com Card (slot 14) recognizes this failure and becomes active on the bus. Modbus and OPC data are now only provided by the secondary Com Card.

After replacing the defect primary Com Card, the secondary Com Card stays active at the bus. The replaced Com Card gets data from the secondary Com Card and continues with providing Modbus and OPC UA data.

Figure 7-2: Example: Primary card fails

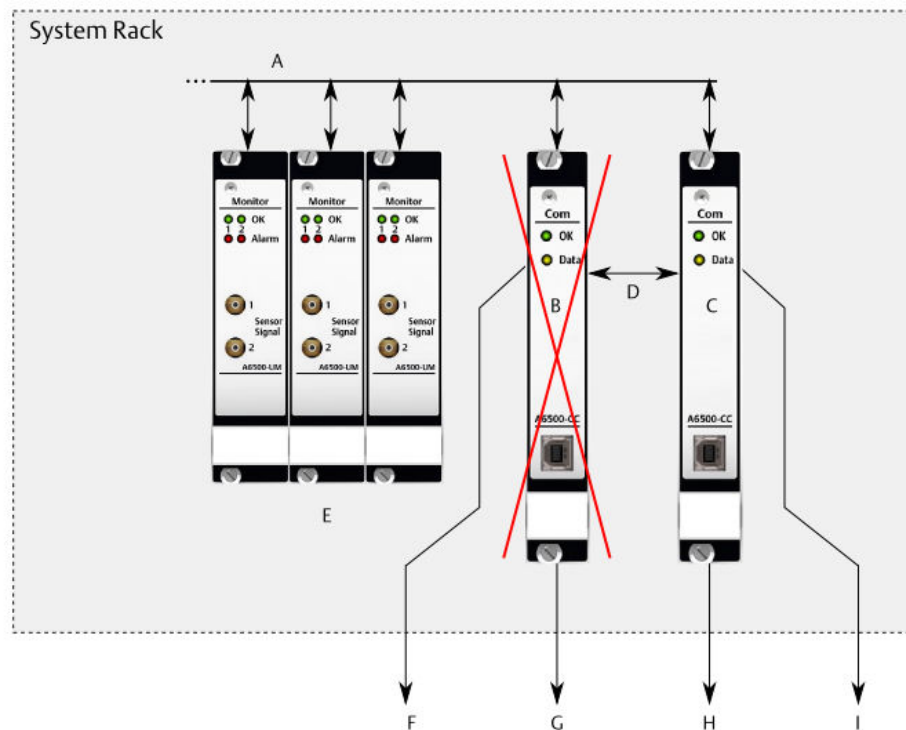

- A. System Rack Bus
- B. Primary Master (Slot 13)
- C. Secondary Master (Slot 14)
- D. Com Card link
- E. Cards
- F. Primary Master: Modbus over TCP/IP and OPC UA
- G. Primary Master: Modbus RTU
- H. Secondary Master: Modbus over TCP/IP and OPC UA
- I. Secondary Master: Modbus RTU

7.1 Configuration

See [Configuration editor and parameters](#) and AMS Machine Studio operating manual for the general configuration procedure and the parameter description. For a redundant communication configure the parameters listed in [Table 7-1](#).

Table 7-1: Parameters for redundancy

Configuration Page	Parameter
LAN	Primary IP address
	Primary subnet mask
	Primary gateway
	Secondary IP address

Table 7-1: Parameters for redundancy (continued)

Configuration Page	Parameter
	Secondary subnet mask
	Secondary gateway
Modbus	Primary master address
	Secondary master address
Modbus RTU ¹	Bus termination primary master
	Biasing resistors primary master
	Bus termination secondary master
	Biasing resistors secondary master

¹ Only if Modbus RTU communication is necessary

Note

Only the active Com Card can be configured.

The configured addresses (IP, subnet mask, and so on) are assigned to the slots and not to the Com Cards. That means that the Com Cards can be swapped or replaced without reconfiguration of the addresses. If one card is replaced, the configuration of the remaining card is automatically copied to the new card. Only at power on, the configuration of the card in slot 13 is always copied to the card in slot 14. [Figure 7-3](#) shows the copy behavior if one card is replaced.

Figure 7-3: Copy of configuration

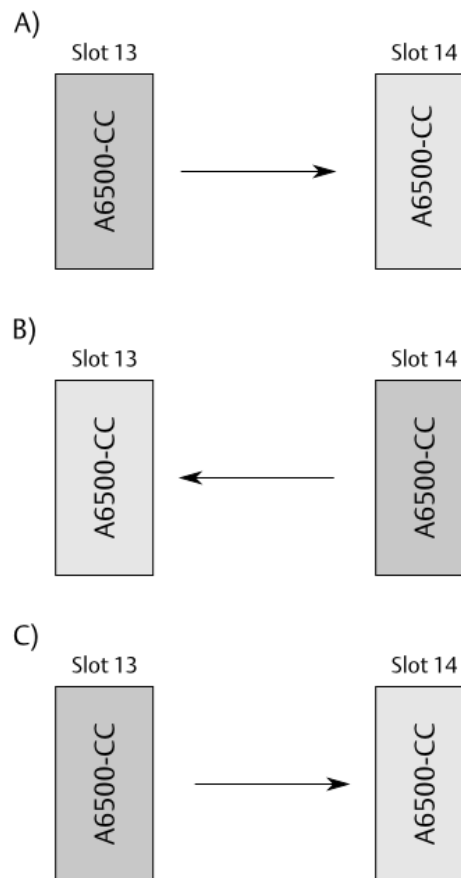

- A. At power on, Com Cards installed in both slots (13 and 14): The configuration file of the Com Card in slot 13 is automatically copied to the card in slot 14.
- B. Already powered on rack, Com Card installed in slot 14: The configuration file of the Com Card in slot 14 is automatically copied to a newly installed Com Card in slot 13.
- C. Already powered on rack, Com Card installed in slot 13: The configuration file of the Com Card in slot 13 is automatically copied to a newly installed Com Card in slot 14.

7.2 Manual change of active/passive state

The A6500-CC Com Card in the left communication card slot is the primary card and in general also the active communication card. In case of communication issues the Com Card in the secondary communication card slot (right slot) becomes automatically active and the primary Com Card in the left slot becomes passive. If there is a need to switch back a Com Card into the active state, reboot the currently active Com Card and the currently passive Com Card becomes active.

For the state of the A6500-CC Com Card (active or passive) see **Online View** → **Overview** → **Redundancy** or Modbus **Holding** register / OPC UA data point **Info.IsActiveCard**.

Table 7-2: Modbus Holding register – Active/passive state

Register	Type	Name	Description
65106	16 Bit Integer	Active Com Card left slot	Indication whether the Com Card in the left-most communication card slot is active. 1: active 0: passive
65116	16 Bit Integer	Active Com Card right slot	Indication whether the Com Card in the right communication card slot is active. 1: active 0: passive

⚠ CAUTION

All connections to the A6500-CC Com Card are disconnected during the reboot. Afterward the connections are automatically reestablished.

Data collections in progress are interrupted.

Perform a reboot using one of the following options:

Modbus Modbus **Holding** register **RebootComCard**, available if **Configuration** → **Basic** → **Allow reboot by Modbus/OPC UA** is activated.

Table 7-3: Modbus Holding register – Reboot

Register	Type	Name	Description
64004	16 Bit Integer	Reboot Com Card left	Use this register to send a command to reboot the A6500-CC in the left communication card slot. -1: Waiting for command 0: Busy 1: Send reboot

Table 7-3: Modbus Holding register – Reboot (continued)

Register	Type	Name	Description
64005	16 Bit Integer	Reboot Com Card right	Use this register to send a command to reboot the A6500-CC in the right communication card slot. -1: Waiting for command 0: Busy 1: Send reboot

OPC UA OPC UA data point **Command.RebootComCard**, available if **Configuration** → **Basic** → **Allow reboot by Modbus/OPC UA** is activated.
-1: Waiting for command
0: Busy
1: Send reboot command

AMS Machine Studio Online command **Reboot**. See [Online commands](#).

8 Online View

In AMS Machine Studio, when you connect to an A6500-xR System Rack, the Online View of the connected rack appears on the main page. [Figure 8-1](#) shows this view.

Figure 8-1: Overview Online View

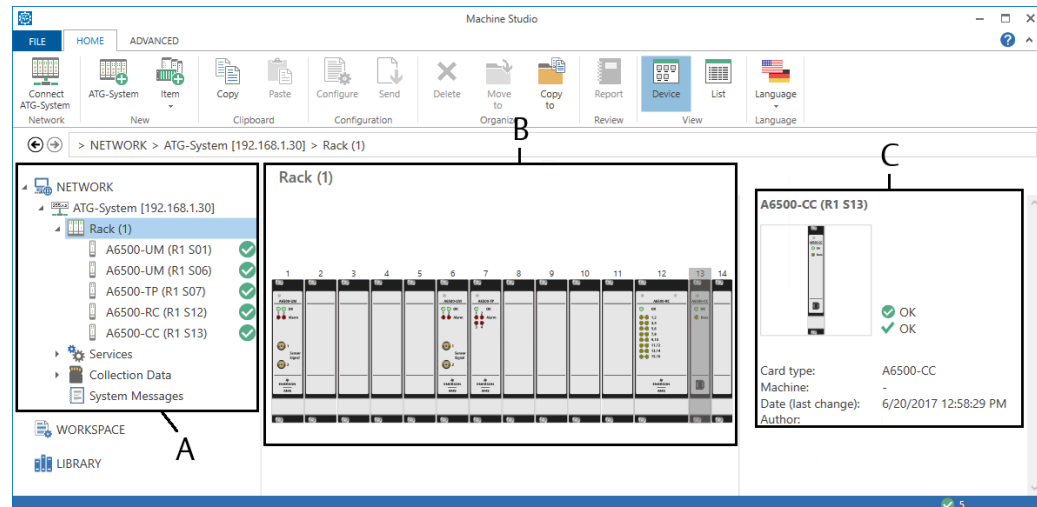

- A. Connected devices with state indication.
- B. Main window with rack view.
- C. A few details of the selected card from the rack overview.

Click an A6500-CC card in the device tree or double click a A6500-CC card shown in the rack view to open the Online View of the card. The Online View has two pages. **Overview** and **Details**. Machine name, plant name, area, serial number, module type, firmware version, date of last change to the configuration, and the author of the last configuration are shown at the top of each online view page. There is a small additional icon, "No configuration". This icon appears on the card symbol in the **Network** list if the card has no configuration.

No configuration

Figure 8-2: No configuration



A Com Card without a configuration is marked with this symbol. This card state is also indicated by slowly flashing of the green OK LED on the front plate.

Note

The information and data on these pages are helpful for finding the cause of an unexpected behavior of the card.

8.1 Overview

Figure 8-3 shows the Overview page.

Figure 8-3: Overview

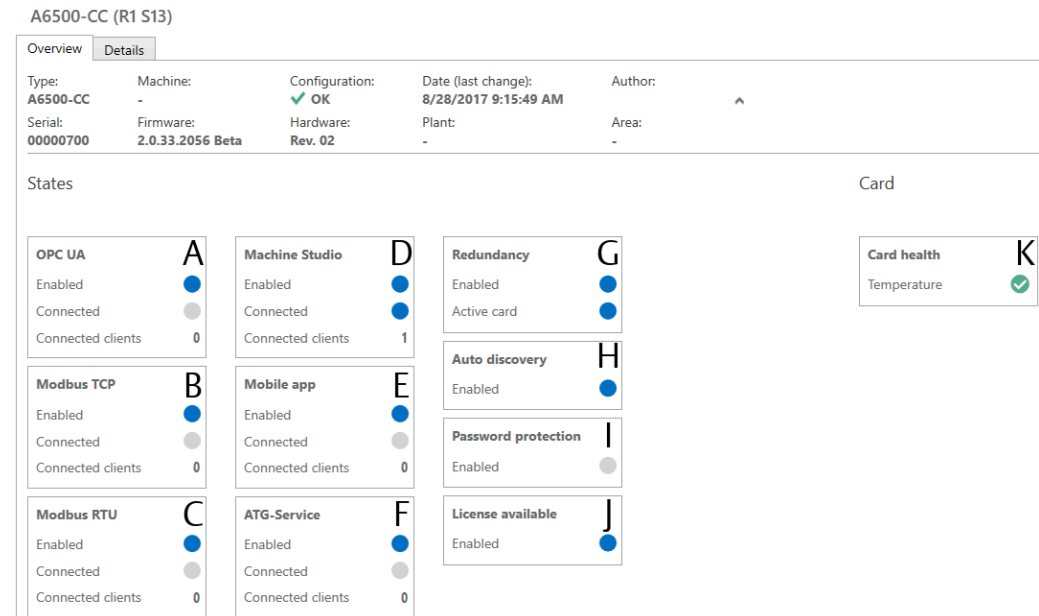

- A. State OPC UA connection
- B. State Modbus TCP connection
- C. State Modbus serial connection
- D. State AMS Machine Studio connection
- E. State Mobile app connection
- F. State ATG Service connection
- G. State Redundancy
- H. State Auto discovery
- I. State Password protection
- J. State of the data collection license
- K. Card health information

State of the interface connection

These graphic objects display the state of the following interfaces:

- OPC UA
- Modbus TCP
- Modbus RTU
- AMS Machine Studio
- Mobile app
- AMS 6500 ATG Service

The graphic objects contain the following information:

- **Enabled**
The state of the interface is indicated. A blue solid circle indicates an enabled interface. The solid circle is gray if the interface is disabled (see Com Card configuration).
- **Connected**
Indicates a connection from the interface to the Com Card. An established connection is indicated with a blue solid circle. Otherwise the circle is gray.
- **Connected clients**
Displays the number of interface clients connected to the Com Card.

Redundancy

The enabled redundancy function is indicated with a blue solid circle. This circle is gray, if no second Com Card is installed.

The active Com Card is indicated with a blue solid circle. Otherwise this circle is gray.

Auto discovery

The enabled auto discovery function is indicated with a blue solid circle. Otherwise this circle is gray. For further information see [Auto discovery](#).

Password protection

The enabled password protection is indicated with a blue solid circle. Otherwise this circle is gray. For further information see [Online commands](#).

License available



An enabled ATG Prediction Extension license for the data collection is indicated with a blue solid circle. This circle is gray if no license is available.

Card health

This graphic object indicates the card health.

- A fault free card is indicated by a check mark within a green solid circle.
- A faulty card is marked with a yellow warning triangle.

Click on the row **Card health** to expand the object and get more information about the card health. Table 7-2 explains these flags.

Flag	Meaning	Action
Temperature	Green solid circle with check mark 	No over-temperature. ---
	Yellow warning mark 	The temperature, measured by the internal temperature sensor, has exceeded the alert limit of 70°C. Take appropriate measures to reduce the environmental temperature.

Flag	Meaning	Action
	Red solid circle with x 	The temperature, measured by the internal temperature sensor, has exceeded the shut down limit of 80°C. We recommend to replace the card as parts might be stressed or damaged because of the high temperature. Take appropriate measures to reduce the environmental temperature.

8.2 Details

Figure 8-4 shows the **Details** page. Some graphic objects on this page are the same as on the **Overview** page (see [Overview](#)). Only new graphic objects are described.

Figure 8-4: Details

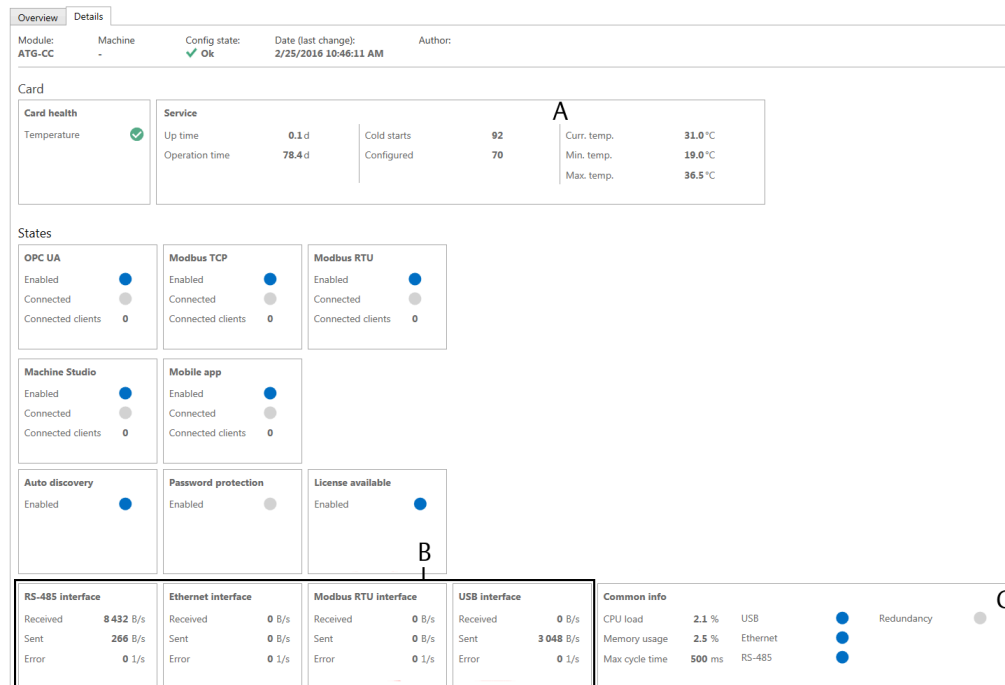

- A. Service data
- B. State of the different interfaces
- C. Common card information

Service data

This graphical object contains some statistical values and temperature information.

- **Up time**
Days in operation since the last power on. This counter is reset at each power on.
- **Operation time**

Days in operation since the first power on.

- **Cold starts**
This counter is increase at every power on.
- **Configured**
This counter is increased at every send configuration.
- **Curr. temp.**
The current temperature, measured by the card internal temperature sensor, is displayed here.
- **Min. temp.**
The minimum measured temperature is displayed here.
- **Max. temp.**
The maximum measured temperature is displayed here.

RS485 Interface, Ethernet Interface, Modbus RTU Interface, and USB Interface

These graphic objects contain a communication error counter and indicate the communication speed.

Common info

This graphical object shows the CPU load, the maximum cycle time and the usage of the internal memory. Active interfaces and redundancy are indicated with a blue solid circle, inactive interfaces and redundancy with a gray solid circle.

The cycle time indicates the time within the data of all connected cards is cyclically read. Minimum cycle time is 500 ms.

8.3 Online commands

The A6500-CC card related commands are described. For description of all other buttons of the ribbon command bar see operating manual "AMS Machine Studio - General Functions" (MHM-97879). [Figure 8-5](#) shows the ribbon command bar with the marked online commands.

Note

Ensure that there is an online connection to the card before using these commands.

Figure 8-5: Command buttons

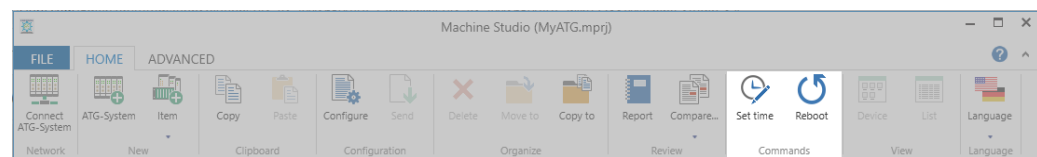

Set Time

Figure 8-6: Button "Set Time"



Click **Set Time** to synchronize the A6500-CC card time with the UTC time (Coordinated Universal Time).

Reboot

Figure 8-7: Button "Reboot"



Click **Reboot** to reboot the A6500-CC Com Card. The A6500-CC reboots immediately.

⚠ CAUTION

All connections to the A6500-CC Com Card are disconnected during the reboot. Afterward the connections are automatically reestablished.

Data collections in progress are interrupted.

9 Functions and applications

9.1 Single Com Card communication

For single Com Card communication one Com Card must be installed. Emerson recommends to install the card into the left Com Card slot (CD13) of the System Rack (A6500-SR or A6500-RR). This is the minimum setup for a AMS 6500 ATG system as the Com Card is required for the configuration of the complete system.

The Modbus RTU interface works as a slave interface.

Table 9-1 shows an example configuration with Modbus over TCP/IP and Modbus RTU communication.

Table 9-1: Single card communication - example configuration

Configuration page	Parameter	Value
LAN	Primary IP address	IP addresses depend on the local network settings, generally provided by the local system administrator.
	Primary subnet mask	
	Primary gateway	
	Secondary IP address	Enter primary addresses - slot not used
	Secondary subnet mask	
	Secondary gateway	
Modbus	Primary master address	1
	Secondary master address	Enter primary address - slot not used
	Read response for unmapped register	Illegal data address
	Write response for unmapped register	Illegal data address
Modbus TCP	Enabled	Box checked
	Port	502 (Modbus standard)
Modbus RTU	Enabled	Box checked
	Serial bus speed	19200 baud
	Serial Modbus mode	Only active card responses
	Serial bus parity	Even
	Response delay time	0
	Bus termination primary master	Box checked
	Biasing resistors primary master	Box checked
	Bus termination secondary master	Box not checked
Biasing resistors secondary master	Box not checked	

9.2 Redundant Com Card communication

For the redundancy two Com Cards, installed into the AMS 6500 ATG system, are required. The following communication interfaces are redundant:

- RS 485 interface for communication between cards and Com Card
- Modbus over TCP/IP communication
- Modbus over RTU communication (salve interface)
- OPC UA

Both communication cards are interconnected by the backplane. The primary master card (left slot) operates as the master on the RS 485 bus. The secondary master card is passive on the RS 485 bus. The primary master card collects the data from all connected cards. The data is mirrored to the secondary, passive card. Both Com Cards provides the data through the Modbus and OPC UA interfaces. If the primary master card fails then the secondary master card becomes the master on the RS 485 bus and takes over the communication with the connected cards. There are different redundant Modbus communication setups:

9.2.1 Modbus RTU - Both cards with an identical device address

Figure 9-1 shows a connection overview of a redundant Modbus RTU. Function:

- Single Modbus RTU connection to the control system.
- Both Com Cards have an identical device address.
Only active card responses is selected for parameter **Modbus RTU → Serial Modbus mode**.
- The primary master provides Modbus RTU data.
- Bus termination at primary master
- Bias activated at primary master
- If the primary master fails, the secondary master becomes active and provides Modbus data. The bus termination and the bias are automatically activated at the secondary master.

Figure 9-1: Redundant Modbus RTU with identical device address

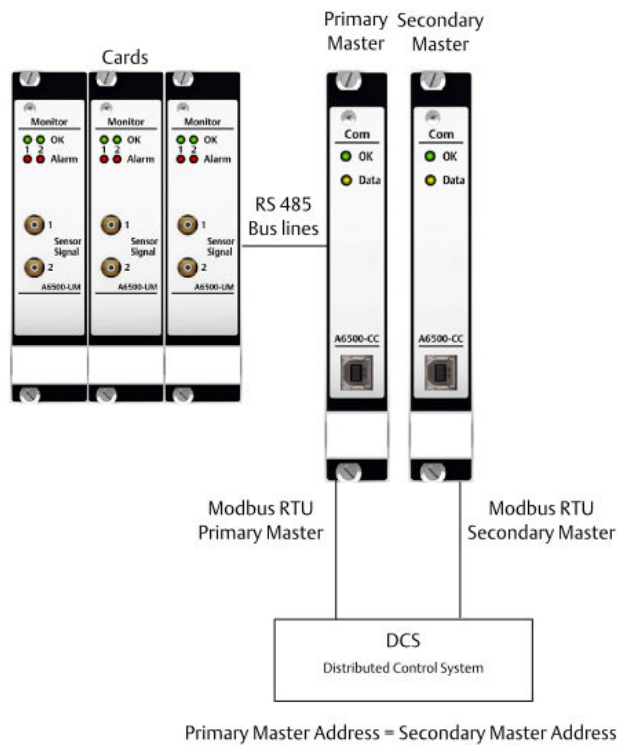

Table 9-2 shows an example configuration for redundant Modbus RTU communication with identical master addresses.

Table 9-2: Redundant card communication - example configuration Modbus RTU with same address

Configuration page	Parameter	Value
LAN	Primary IP address	IP addresses depend on the local network settings, generally provided by the local system administrator. If Ethernet communication is not required leave the default IP settings as they are.
	Primary subnet mask	
	Primary gateway	
	Secondary IP address	
	Secondary subnet mask	
	Secondary gateway	
Modbus	Primary master address	1
	Secondary master address	1
	Read response for unmapped register	Illegal data address
	Write response for unmapped register	Illegal data address
Modbus RTU	Enabled	Box checked
	Serial bus speed	19200 baud

Table 9-2: Redundant card communication - example configuration Modbus RTU with same address (continued)

Configuration page	Parameter	Value
	Serial Modbus mode	Only active card responses
	Serial bus parity	Even
	Response delay time	0
	Bus termination primary master	Box checked
	Biasing resistors primary master	Box checked
	Bus termination secondary master	Box not checked (automatically activated if master fails.)
	Biasing resistors secondary master	Box not checked (automatically activated if master fails.)

9.2.2 Modbus RTU - Com Cards with unique device addresses

Figure 9-2 shows a connection overview of a redundant Modbus RTU communication. Function:

- Single Modbus RTU connection to the control system.
- Each Com Card has an unique address.
Both card responses is selected for parameter **Modbus RTU** → **Serial Modbus mode**.
- The primary master and secondary master provide Modbus RTU data.
- Bus termination at primary master
- Bias activated at primary master
- If the primary master fails, the secondary master becomes active and takes over the communication with the cards. The bus termination and the bias are automatically activated at the secondary master.

Figure 9-2: Redundant Modbus RTU with unique device addresses

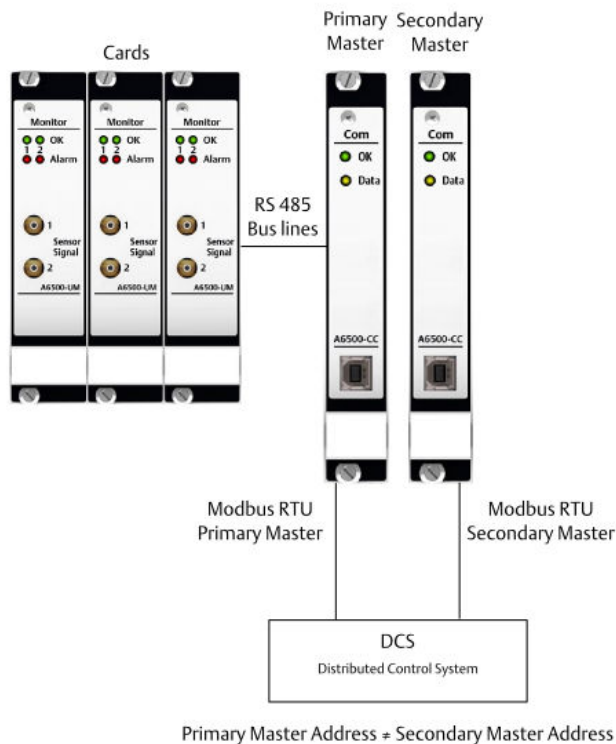

Table 9-3 shows an example configuration for redundant Modbus RTU communication with unique master addresses.

Table 9-3: Redundant card communication - example configuration Modbus RTU with unique device addresses

Configuration page	Parameter	Value
LAN	Primary IP address	IP addresses depend on the local network settings, generally provided by the local system administrator. If Ethernet communication is not required leave the default IP settings as they are.
	Primary subnet mask	
	Primary gateway	
	Secondary IP address	
	Secondary subnet mask	
	Secondary gateway	
Modbus	Primary master address	1
	Secondary master address	2
	Read response for unmapped register	Illegal data address
	Write response for unmapped register	Illegal data address
Modbus RTU	Enabled	Box checked
	Serial bus speed	19200 baud

Table 9-3: Redundant card communication - example configuration Modbus RTU with unique device addresses (continued)

Configuration page	Parameter	Value
	Serial Modbus mode	Both card responses
	Serial bus parity	Even
	Response delay time	0
	Bus termination primary master	Box checked
	Biasing resistors primary master	Box checked
	Bus termination secondary master	Box not checked (automatically activated if master fails.)
	Biasing resistors secondary master	Box not checked (automatically activated if master fails.)

9.2.3 Modbus over TCP/IP - both cards within the same LAN

Figure 9-3 shows a connection overview of a redundant Modbus over TCP communication whereat both Com Card are connected to the same LAN¹. Function:

- Both Com Cards are connected through the same LAN.
- The primary master and secondary master provide Modbus data.
- If the primary master fails, the secondary master becomes active and takes over the communication with the cards.

¹ Local Area Network

Figure 9-3: Modbus over TCP/IP - both cards within the same LAN

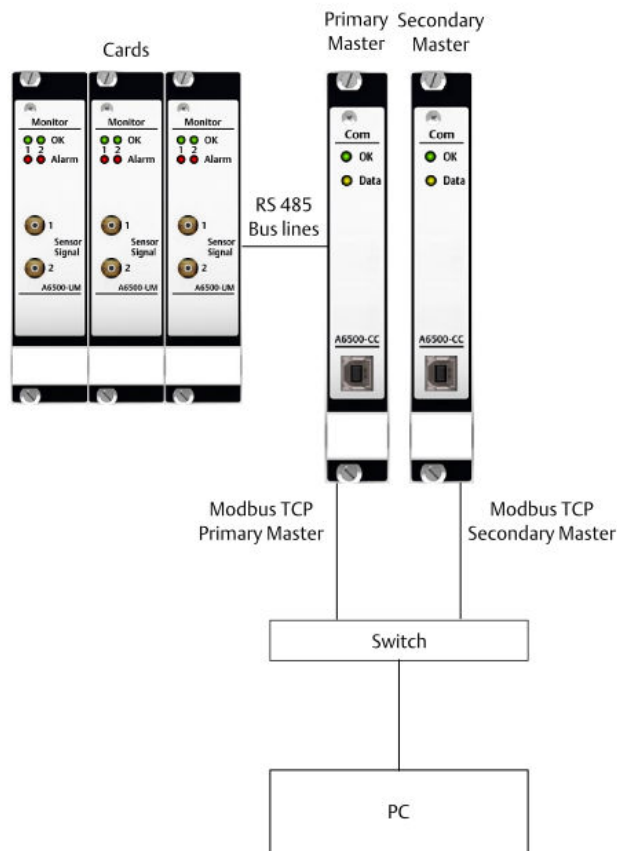

Table 9-4 shows an example configuration for redundant Modbus over TCP/IP with both Com Cards connected to the same LAN.

Table 9-4: Modbus over TCP/IP - example configuration both cards within the same LAN

Configuration page	Parameter	Value
LAN	Primary IP address	IP addresses depend on the local network settings, generally provided by the local system administrator.
	Primary subnet mask	
	Primary gateway	
	Secondary IP address	
	Secondary subnet mask	
	Secondary gateway	
Modbus	Primary master address	1 (also required for Modbus over TCP/IP)
	Secondary master address	2 (also required for Modbus over TCP/IP)
	Read response for unmapped register	Illegal data address

Table 9-4: Modbus over TCP/IP - example configuration both cards within the same LAN (continued)

Configuration page	Parameter	Value
	Write response for unmapped register	Illegal data address
Modbus TCP	Enabled	Box checked
	Port	502 (Modbus standard)
	Use IP white list	Box checked
	IP address 1 - IP address 5	Enter here the IP addresses of devices that are allowed to access the Modbus over TCP/IP interface.

9.2.4 Modbus over TCP/IP - two separate LANs

Figure 9-4 shows a connection overview of a redundant Modbus over TCP communication whereat the Com Cards are connected to different LANs. Function:

- Both Com Cards are connected through different networks (network (a) and network (b)).
- The primary master and secondary master provide Modbus data.
- If the primary master fails, the secondary master becomes active and takes over the communication with the cards.

Figure 9-4: Modbus over TCP/IP - two separate LANs

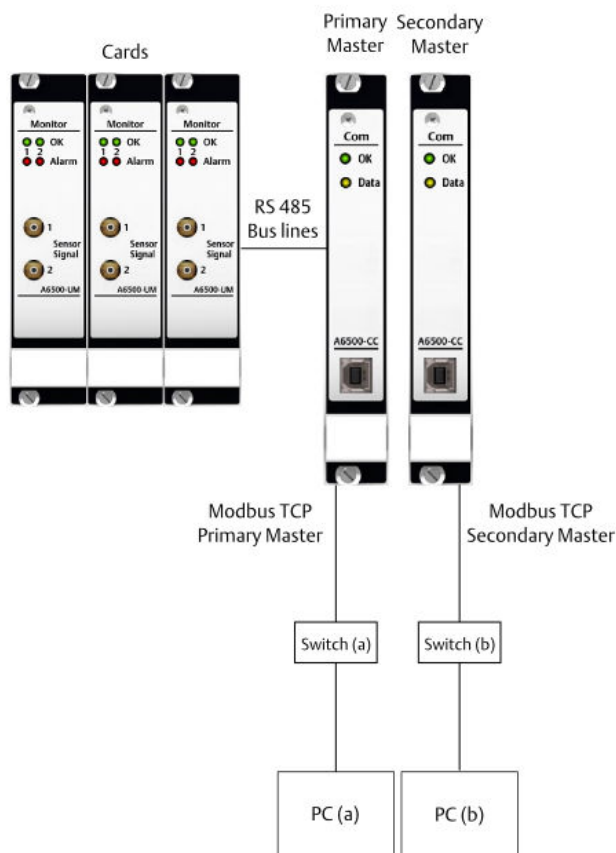

Table 9-5 shows an example configuration for redundant Modbus over TCP/IP whereat the Com Cards are connected to different LANs.

Table 9-5: Modbus over TCP /IP - example configuration with Com Cards connected to different LANs

Configuration page	Parameter	Value
LAN	Primary IP address	IP addresses depend on the local network settings, generally provided by the local system administrator.
	Primary subnet mask	
	Primary gateway	
	Secondary IP address	
	Secondary subnet mask	
Modbus	Primary master address	1 (also required for Modbus over TCP/IP)
	Secondary master address	2 (also required for Modbus over TCP/IP)
	Read response for unmapped register	Illegal data address
	Write response for unmapped register	Illegal data address

Table 9-5: Modbus over TCP/IP - example configuration with Com Cards connected to different LANs (continued)

Configuration page	Parameter	Value
Modbus TCP	Enabled	Box checked
	Port	502 (Modbus standard)
	Use IP white list	Box checked
	IP address 1 - IP address 5	Enter here the IP addresses of devices which are allowed to access the Modbus over TCP/IP interface.

10 Maintenance

The A6500-CC Com Card does not require any maintenance during normal operation.

11 Replace a Com Card

Follow this procedure if a Com Card needs to be replaced. This could be, for example, necessary due to a defect. The Com Card is hot-swappable.

⚠ CAUTION

Any work on the system may impair machine protection.

Procedure

1. Where applicable, disconnect the Ethernet connection at the rear of the Com Card.
 2. Unfasten the screws at the front plate and remove the card from the slot.
 3. Push the new Com Card firmly but gently into the slot.
 4. Hand-tighten both screws at the front plate to secure the card.
 5. Where applicable, reconnect the Ethernet cable.
 6. Establish a connection between AMS Machine Studio and Com Card to set the IP Addresses and Modbus parameters.
 7. Send the configuration to the card.
A solid green OK LED indicates the Com Card is working.
-

Note

No additional configuration is required for a redundant communication setup. The configuration of the remaining card will be automatically copied to the replaced card.

12 Technical data

Only specifications with indicated tolerances or limit values are binding. Data without tolerances or without error limits are informative data and not guaranteed. Technical modification, especially of the software, are subject to changes without notice. If not specified otherwise, all data are referred to an environmental temperature of +25°C.

12.1 Power supply

Nominal voltage	+24 V	redundant supply voltage inputs protected against polarity reversal
Permissible voltage range	+19 V to +32 V DC	in case of a single failure, supply voltage must not exceed the level of IEC 60204-1 or IEC 61131-2 (SELV/PELV)
Overvoltage protection	>+33 V DC	card shuts down at overvoltage condition
Maximum power consumption	4 W	

12.2 Interfaces

RS 485		
Communication bus	RS 485	according to EIA485 standard
Number of bus lines	6	
Maximum data rate	512 kbit	

Ethernet		
Connector	RJ45	
Data rate	10/100 Mbit	with auto negotiation and auto MDI-X
Maximum cable length	100m	shielded cable required
Voltage	2 V peak-to-peak	
Rated current	100 mA	
Rated power	200 mW	

USB interface		
Socket	type B	
Isolation	interface is connected to earth	

Modbus		
Communication bus	RS 485	according to EIA485 standard
Bus termination	internal	line polarization and termination switchable by configuration
Data rate	9600 or 19.2 kBaud	default 19.2 kBaud
Voltage	200 mV peak-to-peak	
Rated current	1.6 mA	
Rated power	0.4 mW	

12.3 Mechanical design and environmental conditions

Mechanical design		
Rack slot	3RU/4HP	
Material front panel	aluminum, clear anodized	
Board dimensions	100x160 mm + Ethernet extension	euro-card format conform to IEC 60297
Board coating	Airborne contaminants resistance	ISA-S71.04-1985 airborne contaminants class G3, Conformal Coating
	Material: HumiSeal® 1B31 EPA	according to IPC-CC-830B and IPC-A 610
Card connector	type C30 male	according to IEC 60603-2
Status indication	LED (3mm)	one green OK and one yellow Data LED at front panel
Weight	approximately 170 g	without packaging
Overall dimensions		see Figure 12-1

Environmental conditions		
Protection class	IP20	according to IEC 60529 rack mounted, otherwise IP00
Approval class for general safety	Class 2253 01	industrial automation products
	Class 2253 81	industrial automation products - (certified to U.S. standards)
Allowed degree of pollution	Category 2	according to IEC 61010-1
Operating temperature	-20°C to +70°C	with forced cooling ¹
	-20°C to +55°C	without forced cooling
Storage temperature	-40°C to +85°C	

Environmental conditions		
Relative humidity	5 to 95%	noncondensing
Shock	150 m/s ²	according to IEC 60068-2-27, 4000 shocks per axis
Vibration	0.15 mm 20 m/s ²	10 to 55Hz 55 to 150Hz according to IEC 60068-2-6, float sinus, three axis
Operating altitude	<2000 m	above see level
Environmental area	Indoor use only	
External devices		in case of a single failure, externally connected devices must not exceed the level of IEC60204-1 or IEC 61131-2

¹ An airflow of $\geq 440 \text{ m}^3/\text{h}$ is required.

Figure 12-1: Dimensions

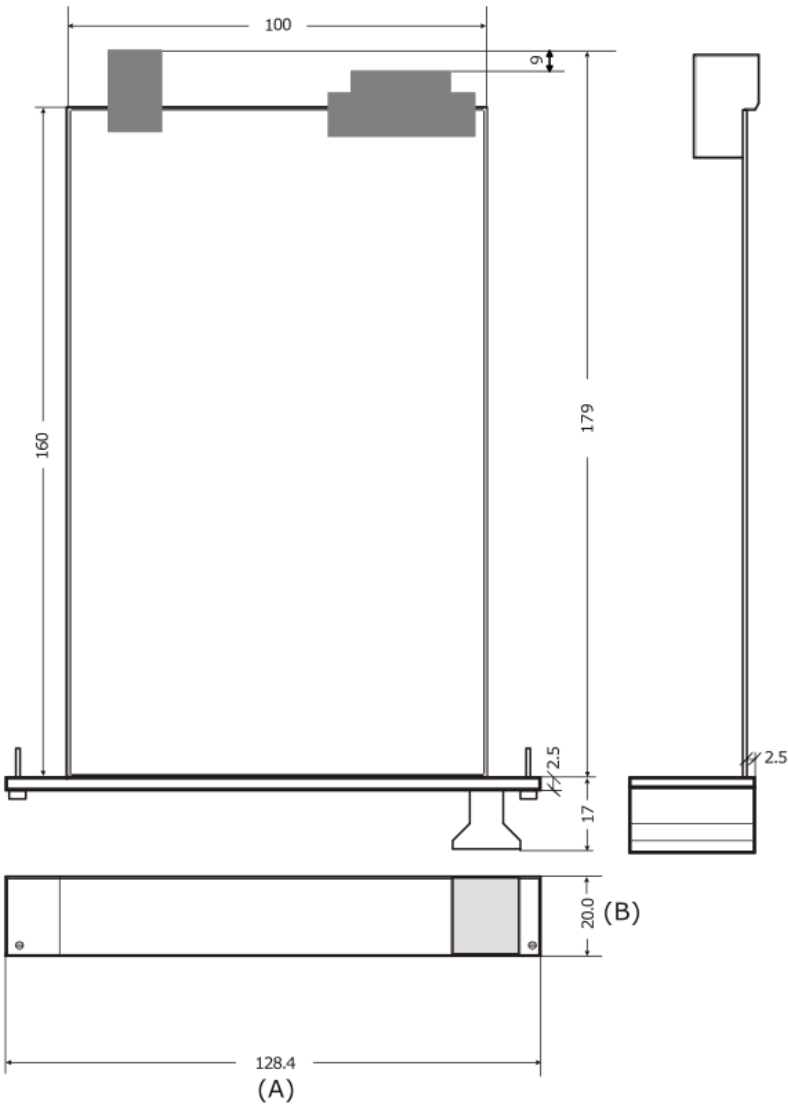

- A. 3 RU
- B. 4 HP

All dimensions in mm

13 Certificates



EU-Declaration of Conformity (Translation)

We: epro GmbH, Jöbkesweg 3, 48599 Gronau
declare under our sole responsibility that following product(s):

Product designation:	AMS 6500 ATG
Product description:	Protection system for rotating equipment with integrated prediction capabilities
Part numbers	A6500-CC A6500-UM A6500-TP A6500-RC A6500-SR A6500-RR A6500-FR

are in conformity with the terms of the directives mentioned below including any amendment valid at the date of declaration:

2014/30/EU	Electromagnetic compatibility
2014/34/EU	Equipment and protective system intended for use in potentially explosive atmospheres
2011/65/EU	The restriction of the use of certain hazardous substances in electrical and electronic equipment

Following harmonized standards have been applied:

2014/30/EU	EN 61326-1	Electrical equipment for measurement, control and laboratory use. EMC requirements.
2014/34/EU	EN 60079-0	Part 1: General requirements
		Explosive atmospheres -
	Part 0: Equipment - General requirements	
	EN 60079-7	Explosive atmospheres -
		Part 7: Equipment protection by increased safety "e"
2011/65/EU	EN 63000	Technical documentation for the assessment of electrical and electronic products with respect to the restriction of hazardous substances

For the type examination according to EN 60079-0 and EN 60079-7 the following notified body has been involved;

DEKRA EXAM GmbH
Type examination certificate BVS 16 ATEX E 016 U

Authorized person for technical documentation:
Bruno Hecker, Jöbkesweg 3, 48599 Gronau

Gronau, 06 May 2022
Place, Date

Managing Director

Quality



EU-Konformitätserklärung (Original)



Wir: epro GmbH, Jöbkesweg 3, 48599 Gronau
erklären in alleiniger Verantwortung, dass folgende Produkte:

Produktbezeichnung: AMS 6500 ATG
Produktbeschreibung: Schutzsystem für rotierende Maschinen mit integrierten Diagnosemöglichkeiten
Artikelnummern: A6500-CC
A6500-UM
A6500-TP
A6500-RC
A6500-SR
A6500-RR
A6500-FR

den Bestimmungen der unten genannten Richtlinien, einschließlich deren zum Zeitpunkt der Erklärung geltenden Änderungen, entsprechen:

2014/30/EU	Elektromagnetische Verträglichkeit
2014/34/EU	Geräte und Schutzsysteme zur bestimmungsgemäßen Verwendung in explosionsgefährdeten Bereichen
2011/65/EU	Beschränkung der Verwendung bestimmter gefährlicher Stoffe in Elektro- und Elektronikgeräten

Folgende harmonisierte Normen wurden angewandt:

2014/30/EU	EN 61326-1	Elektrische Mess-, Steuer-, Regel- und Laborgeräte – EMV Anforderungen - Teil 1: Allgemeine Anforderungen
2014/34/EU	EN 60079-0	Explosionsgefährdete Bereiche - Teil 0: Betriebsmittel – Allgemeine Anforderungen
	EN 60079-7	Explosionsgefährdete Bereiche - Teil 7: Geräteschutz durch erhöhte Sicherheit "e"
2011/65/EU	EN 63000	Technische Dokumentation zur Beurteilung von Elektro- und Elektronikgeräten hinsichtlich der Beschränkung gefährlicher Stoffe

Für die Baumusterprüfung nach EN 60079-0 und EN 60079-7 ist folgende Benannte Stelle eingeschaltet worden:

DEKRA EXAM GmbH
Baumusterprüfnummer BVS 16 ATEX E 016 U

Bevollmächtigter für die Technische Dokumentation:

Bruno Hecker, Jöbkesweg 3, 48599 Gronau

Gronau, 06. Mai 2022
Ort, Datum

Geschäftsführung

Qualitätsmanagement



UKCA-Declaration of Conformity

We, the manufacturer: epro GmbH, Jöbkesweg 3, 48599 Gronau, Germany
declare under our sole responsibility that following product(s):

Product designation:	AMS 6500 ATG
Product description:	Protection system for rotating equipment with integrated prediction capabilities
Part numbers	A6500-CC A6500-UM A6500-TP A6500-RC A6500-SR A6500-RR

are in conformity with the terms of the directives mentioned below including any amendment valid at the date of declaration:

S.I. 2016 No. 1091	Electromagnetic Compatibility Regulations 2016
S.I. 2016 No. 1107	Equipment and Protective Systems Intended for use in Potentially Explosive Atmospheres Regulations 2016
S.I. 2012 No. 3032	The restriction of the use of certain hazardous substances in electrical and electronic equipment

Following standards have been applied:

S.I. 2016 No. 1091	EN 61326-1	Electrical equipment for measurement, control and laboratory use. EMC requirements. Part 1. General requirements
S.I. 2016 No. 1107	EN 60079-0	Explosive atmospheres -Part 0: Equipment- General requirements
	EN 60079-7	Explosive atmospheres - Part 7: Equipment protection by increased safety "e"
S.I. 2012 No. 3032	EN IEC 63000	Technical documentation for the assessment of electrical and electronic products with respect to the restriction of hazardous substances

For the type examination according to EN 60079-0 and EN 60079-7 the following notified body has been involved:

DEKRA Testing and Certification GmbH
Type examination certificate BVS 16 ATEX E 016 X

Authorized person for technical documentation:

Bruno Hecker, Jöbkesweg 3, 48599 Gronau, Germany

Authorized Representative:

Emerson Process Management Limited,
company No 00671801
Meridian East,
Leicester
LE19 1UX, United Kingdom
Regulatory Compliance Department
email: ukproductcompliance@emerson.com
Phone: +44 11 6282 23 64

M. Fränzer
Managing Director

B. Hecker
Quality

Place, Date: Gronau, 13 September 2022



Emerson Process Management
1100 W. Louis Henna Blvd.
Round Rock, TX 78681

Statement Regarding the China RoHS Compliance of Emerson Product – A6500-UM

Please refer to Table 1 for the names and contents of the toxic or hazardous substances or elements contained in Emerson products.

Table 1: Names and Contents of Toxic or Hazardous Substances or Elements
表1：有毒有害物质或元素的名称及含量

部件名称 Part Name	有毒有害物质或元素 Toxic or hazardous Substances and Elements						
	铅 Lead (Pb)	汞 Mercury (Hg)	镉 Cadmium (Cd)	六价铬 Hexavalent Chromium (Cr (VI))	多溴联苯 Polybrominated biphenyls (PBB)	多溴二苯醚 Polybrominated diphenyl ethers (PBDE)	
印刷电路板组装 PC BD ASSY	X	0	0	0	0	0	
面板 FACEPLATE	0	0	0	0	0	0	
印刷电路板组装支持 PC BD ASSY SUPPORT	0	0	0	0	0	0	
<p>0 表示该有毒有害物质在该部件所有均质材料中的含量均在GB/T 26572规定的限量要求以下 0: Indicates that this toxic or hazardous substance contained in all of the homogeneous materials for this part is below the limit requirement in GB/T 26572.</p> <p>X 表示该有毒有害物质至少在该部件的某一均质材料中的含量超出GB/T 26572规定的限量要求。 X: Indicates that this toxic or hazardous substance contained in at least one of the homogeneous materials used for this part is above the limit requirement in GB/T 26572</p> <p>环保期限 (EFUP) 的产品及其部件是每个列出的符号，除非另有标明。使用期限只适用于产品在产品手册中规定的条件下工作 The Environmentally Friendly Period (EFUP) for the product and its parts are per the symbol listed, unless otherwise marked. Use Period is valid only when the product is operated under the conditions defined in the product manual.</p>							

James McFerrin
Environmental Compliance Manager PSG
T 512.832.3271 E james.mcferrin@emerson.com



Emerson Process Management
1100 W. Louis Henna Blvd.
Round Rock, TX 78681

Statement Regarding the China RoHS Compliance of Emerson Product – A6500-TP

Please refer to Table 1 for the names and contents of the toxic or hazardous substances or elements contained in Emerson products.

Table 1: Names and Contents of Toxic or Hazardous Substances or Elements
表1：有毒有害物质或元素的名称及含量

部件名称 Part Name	有毒有害物质或元素 Toxic or hazardous Substances and Elements						
	铅 Lead (Pb)	汞 Mercury (Hg)	镉 Cadmium (Cd)	六价铬 Hexavalent Chromium (Cr (VI))	多溴联苯 Polybrominated biphenyls (PBB)	多溴二苯醚 Polybrominated diphenyl ethers (PBDE)	
印刷电路板组装 PC BD ASSY	X	0	0	0	0	0	
面板 FACEPLATE	0	0	0	0	0	0	
印刷电路板组装支持 PC BD ASSY SUPPORT	0	0	0	0	0	0	
0 表示该有毒有害物质在该部件所有均质材料中的含量均在GB/T 26572规定的限量要求以下 0: Indicates that this toxic or hazardous substance contained in all of the homogeneous materials for this part is below the limit requirement in GB/T 26572.							
X 表示该有毒有害物质至少在该部件的某一均质材料中的含量超出GB/T 26572规定的限量要求。 X: Indicates that this toxic or hazardous substance contained in at least one of the homogeneous materials used for this part is above the limit requirement in GB/T 26572.							
环保期限 (EFUP) 的产品及其部件是每个列出的符号，除非另有标明。使用期限只适用于产品在产品手册中规定的条件下工作 The Environmentally Friendly Period (EFUP) for the product and its parts are per the symbol listed, unless otherwise marked. Use Period is valid only when the product is operated under the conditions defined in the product manual.							

James McFerrin
Environmental Compliance Manager PSG
T 512.832.3271 E james.mcferrin@emerson.com



Emerson Process Management
1100 W. Louis Henna Blvd.
Round Rock, TX 78681

Statement Regarding the China RoHS Compliance of Emerson Product – A6500-RC

Please refer to Table 1 for the names and contents of the toxic or hazardous substances or elements contained in Emerson products.

Table 1: Names and Contents of Toxic or Hazardous Substances or Elements
表1：有毒有害物质或元素的名称及含量

部件名称 Part Name	有毒有害物质或元素 Toxic or hazardous Substances and Elements						
	铅 Lead (Pb)	汞 Mercury (Hg)	镉 Cadmium (Cd)	六价铬 Hexavalent Chromium (Cr (VI))	多溴联苯 Polybrominated biphenyls (PBB)	多溴二苯醚 Polybrominated diphenyl ethers (PBDE)	
印刷电路板组装 PC BD ASSY	X	0	0	0	0	0	
面板 FACEPLATE	0	0	0	0	0	0	
印刷电路板组装支持 PC BD ASSY SUPPORT	0	0	0	0	0	0	
0 表示该有毒有害物质在该部件所有均质材料中的含量均在GB/T 26572规定的限量要求以下 0: Indicates that this toxic or hazardous substance contained in all of the homogeneous materials for this part is below the limit requirement in GB/T 26572.							
X 表示该有毒有害物质至少在该部件的某一均质材料中的含量超出GB/T 26572规定的限量要求。 X: Indicates that this toxic or hazardous substance contained in at least one of the homogeneous materials used for this part is above the limit requirement in GB/T 26572.							
环保期限 (EFUP) 的产品及其部件是每个列出的符号，除非另有标明。使用期限只适用于产品在产品手册中规定的条件下工作 The Environmentally Friendly Period (EFUP) for the product and its parts are per the symbol listed, unless otherwise marked. Use Period is valid only when the product is operated under the conditions defined in the product manual.							

James McFerrin
Environmental Compliance Manager PSG
T 512.832.3271 E james.mcferrin@emerson.com



Emerson Process Management
1100 W. Louis Henna Blvd.
Round Rock, TX 78681

Statement Regarding the China RoHS Compliance of Emerson Product – A6500-CC

Please refer to Table 1 for the names and contents of the toxic or hazardous substances or elements contained in Emerson products.

Table 1: Names and Contents of Toxic or Hazardous Substances or Elements
表1：有毒有害物质或元素的名称及含量

部件名称 Part Name	有毒有害物质或元素 Toxic or hazardous Substances and Elements						
	铅 Lead (Pb)	汞 Mercury (Hg)	镉 Cadmium (Cd)	六价铬 Hexavalent Chromium (Cr (VI))	多溴联苯 Polybrominated biphenyls (PBB)	多溴二苯醚 Polybrominated diphenyl ethers (PBDE)	
印刷电路板组装 PC BD ASSY	X	0	0	0	0	0	
面板 FACEPLATE	0	0	0	0	0	0	
印刷电路板组装支持 PC BD ASSY SUPPORT	0	0	0	0	0	0	
<p>0 表示该有毒有害物质在该部件所有均质材料中的含量均在GB/T 26572规定的限量要求以下 0: Indicates that this toxic or hazardous substance contained in all of the homogeneous materials for this part is below the limit requirement in GB/T 26572.</p> <p>X 表示该有毒有害物质至少在该部件的某一均质材料中的含量超出GB/T 26572规定的限量要求。 X: Indicates that this toxic or hazardous substance contained in at least one of the homogeneous materials used for this part is above the limit requirement in GB/T 26572</p> <p>环保期限 (EFUP) 的产品及其部件是每个列出的符号，除非另有标明。使用期限只适用于产品在产品手册中规定的条件下工作 The Environmentally Friendly Period (EFUP) for the product and its parts are per the symbol listed, unless otherwise marked. Use Period is valid only when the product is operated under the conditions defined in the product manual.</p>							

James McFerrin
Environmental Compliance Manager PSG
T 512.832.3271 E james.mcferrin@emerson.com



Emerson Process Management
1100 W. Louis Henna Blvd.
Round Rock, TX 78681

Statement Regarding the China RoHS Compliance of Emerson Product – A6500-SR

Please refer to Table 1 for the names and contents of the toxic or hazardous substances or elements contained in Emerson products.

Table 1: Names and Contents of Toxic or Hazardous Substances or Elements

表1：有毒有害物质或元素的名称及含量

部件名称 Part Name	有毒有害物质或元素 Toxic or hazardous Substances and Elements						
	铅 Lead (Pb)	汞 Mercury (Hg)	镉 Cadmium (Cd)	六价铬 Hexavalent Chromium (Cr (VI))	多溴联苯 Polybrominated biphenyls (PBB)	多溴二苯醚 Polybrominated diphenyl ethers (PBDE)	
印刷电路板组装 PC BD ASSY	X	0	0	0	0	0	
围堰 ENCLOSURE	0	0	0	0	0	0	
硬件 HARDWARE	0	0	0	0	0	0	
印刷电路板组装支持 PC BD ASSY SUPPORT	0	0	0	0	0	0	
0 表示该有毒有害物质在该部件所有均质材料中的含量均在GB/T 26572规定的限量要求以下 0: Indicates that this toxic or hazardous substance contained in all of the homogeneous materials for this part is below the limit requirement in GB/T 26572.							
X 表示该有毒有害物质至少在该部件的某一均质材料中的含量超出GB/T 26572规定的限量要求。 X: Indicates that this toxic or hazardous substance contained in at least one of the homogeneous materials used for this part is above the limit requirement in GB/T 26572.							
环保期限 (EFUP) 的产品及其部件是每个列出的符号，除非另有标明。使用期限只适用于产品在产品手册中规定的条件下工作 The Environmentally Friendly Period (EFUP) for the product and its parts are per the symbol listed, unless otherwise marked. Use Period is valid only when the product is operated under the conditions defined in the product manual.							

James McFerrin
Environmental Compliance Manager PSG
T 512 832 3271 E james.mcferrin@emerson.com



Emerson Process Management
1100 W. Louis Henna Blvd.
Round Rock, TX 78681

Statement Regarding the China RoHS Compliance of Emerson Product – A6500-RR

Please refer to Table 1 for the names and contents of the toxic or hazardous substances or elements contained in Emerson products.

Table 1: Names and Contents of Toxic or Hazardous Substances or Elements

表1：有毒有害物质或元素的名称及含量

部件名称 Part Name	有毒有害物质或元素 Toxic or hazardous Substances and Elements						
	铅 Lead (Pb)	汞 Mercury (Hg)	镉 Cadmium (Cd)	六价铬 Hexavalent Chromium (Cr (VI))	多溴联苯 Polybrominated biphenyls (PBB)	多溴二苯醚 Polybrominated diphenyl ethers (PBDE)	
印刷电路板组装 PC BD ASSY	X	0	0	0	0	0	
围堵 ENCLOSURE	0	0	0	0	0	0	
硬件 HARDWARE	0	0	0	0	0	0	
印刷电路板组装支持 PC BD ASSY SUPPORT	0	0	0	0	0	0	
<p>0 表示该有毒有害物质在该部件所有均质材料中的含量均在GB/T 26572规定的限量要求以下 0: Indicates that this toxic or hazardous substance contained in all of the homogeneous materials for this part is below the limit requirement in GB/T 26572.</p> <p>X 表示该有毒有害物质至少在该部件的某一均质材料中的含量超出GB/T 26572规定的限量要求。 X: Indicates that this toxic or hazardous substance contained in at least one of the homogeneous materials used for this part is above the limit requirement in GB/T 26572</p> <p>环保期限（EFUP）的产品及其部件是每个列出的符号，除非另有标明，使用期限只适用于产品在产品手册中规定的条件下工作 The Environmentally Friendly Period (EFUP) for the product and its parts are per the symbol listed, unless otherwise marked. Use Period is valid only when the product is operated under the conditions defined in the product manual.</p>							

James McFerrin
Environmental Compliance Manager PSG
T 512 832 3271 E james.mcferrin@emerson.com



Emerson Automation Solutions
1100 W. Louis Henna Blvd.
Round Rock, TX 78681

Statement Regarding the China RoHS Compliance of Emerson Product - A6500-FR

Please refer to Table 1 for the names and contents of the toxic or hazardous substances or elements contained in Emerson products.

Table 1: Names and Contents of Toxic or Hazardous Substances or Elements

表1：有毒有害物质或元素的名称及含量

部件名称 Part Name	有毒有害物质或元素 Toxic or hazardous Substances and Elements						
	铅 Lead (Pb)	汞 Mercury (Hg)	镉 Cadmium (Cd)	六价铬 Hexavalent Chromium (Cr (VI))	多溴联苯 Polybrominated biphenyls (PBB)	多溴二苯醚 Polybrominated diphenyl ethers (PBDE)	
印刷电路板组装 PC BD ASSY	X	0	0	0	0	0	
硬件 HARDWARE	0	0	0	0	0	0	
<p>0 表示该有毒有害物质在该部件所有均质材料中的含量均在GB/T 26572规定的限量要求以下 0: Indicates that this toxic or hazardous substance contained in all of the homogeneous materials for this part is below the limit requirement in GB/T 26572.</p> <p>X 表示该有毒有害物质至少在该部件的某一均质材料中的含量超出GB/T 26572规定的限量要求。 X: Indicates that this toxic or hazardous substance contained in at least one of the homogeneous materials used for this part is above the limit requirement in GB/T 26572</p> <p>环保期限 (EFUP) 的产品及其部件是每个列出的符号，除非另有标明。使用期限只适用于产品在产品手册中规定的条件下工作 The Environmentally Friendly Period (EFUP) for the product and its parts are per the symbol listed, unless otherwise marked. Use Period is valid only when the product is operated under the conditions defined in the product manual.</p>							

James McFerrin
Environmental Compliance Manager
Systems and Solutions
T 512 832 3271 E james.mcferrin@emerson.com



Emerson Automation Solutions
1100 W. Louis Henna Blvd.
Round Rock, TX 78681

Statement Regarding the China RoHS Compliance of Emerson Product - A6500-PE

Please refer to Table 1 for the names and contents of the toxic or hazardous substances or elements contained in Emerson products.

Table 1: Names and Contents of Toxic or Hazardous Substances or Elements

表1：有毒有害物质或元素的名称及含量

部件名称 Part Name	有毒有害物质或元素 Toxic or hazardous Substances and Elements						
	铅 Lead (Pb)	汞 Mercury (Hg)	镉 Cadmium (Cd)	六价铬 Hexavalent Chromium (Cr (VI))	多溴联苯 Polybrominated biphenyls (PBB)	多溴二苯醚 Polybrominated diphenyl ethers (PBDE)	
印刷电路板组装 C PC BD ASSY C	X	O	O	O	O	O	
印刷电路板组装 PC BD ASSY	X	O	O	O	O	O	
硬件 HARDWARE	O	O	O	O	O	O	
<p>O 表示该有毒有害物质在该部件所有均质材料中的含量均在GB/T 26572规定的限量要求以下 O: Indicates that this toxic or hazardous substance contained in all of the homogeneous materials for this part is below the limit requirement in GB/T 26572.</p> <p>X 表示该有毒有害物质至少在该部件的某一均质材料中的含量超出GB/T 26572规定的限量要求。 X: Indicates that this toxic or hazardous substance contained in at least one of the homogeneous materials used for this part is above the limit requirement in GB/T 26572</p> <p>环保期限 (EFUP) 的产品及其部件是每个列出的符号，除非另有标明。使用期限只适用于产品在产品手册中规定的条件下工作 The Environmentally Friendly Period (EFUP) for the product and its parts are per the symbol listed, unless otherwise marked. Use Period is valid only when the product is operated under the conditions defined in the product manual.</p>							

James McFerrin
Environmental Compliance Manager
Systems and Solutions
T 512 832 3271 E james.mcferrin@emerson.com

A Card related system events

The possible system events provided by the A6500-CC card are listed in [Table A-1](#). See column **Cross reference / Note** for further event related information. See Machine Studio – General Functions manual for a common description of the system events.

Table A-1: Card events

Event	Cross reference / Note
No event mapping available for card in [rack number] and [Slot number]	A6500-CC card cannot interpret received events. Ensure that the latest version of AMS Machine Studio is used and resend the configuration of the A6500-CC card and the configuration of the card mentioned in the event.
Redundancy connected	Redundancy
Redundancy disconnected	
Redundancy firmware version mismatch	Redundancy
Redundancy active mode entered	Overview , see Redundancy
Redundancy passive mode entered	
Bus error x	x: bus line 1 to 6 Internal error, cause could be a hardware defect
Memory error x	x: 1 or 2 1: Static memory 2: Dynamic memory Internal error, cause could be a hardware defect
Machine Studio connected	Overview , see State of the interface connection
Machine Studio disconnected	
Mobile App connected	
Mobile App disconnected	
Temperature danger alarm entered	Overview , see Card health
Temperature danger alarm left	
Temperature alert alarm entered	
Temperature alert alarm left	
System time set by user	Online commands
Card started up successfully	-/-
Card detected	Detected card is indicated with rack number, slot number, type, and serial number.

Table A-1: Card events (continued)

Event	Cross reference / Note
Card not communicating	Card with communication issue is indicated with rack number, slot number, and type.
USB connected	Ethernet and USB connection, Overview
USB disconnected	
Ethernet connected	
Ethernet disconnected	
ATG Service interface activated	Overview , see State of the interface connection
ATG Service interface deactivated	
ATG Service connected	
ATG Service disconnected	
Hardware error	Replace the card
Card configured	Send a configuration
Card configuration error	Try to send the configuration again, if this does not solve the problem, contact support, see Technical support .
Card events lost [Rack number] [Slot number] [Number of lost events]	-/-
Event storage clean up x ¹ to y ¹ , z ²	Total number of z events from x to y are deleted
Two active ComCards detected x	x: 0 or 1 0: Other Com Card is expected to reboot 1: Card will be rebooted
Manual reboot of card	Rebooted card is indicated with rack number, slot number, type of command source, and source information. Type of command source: 0: Unknown 1: Modbus 2: OPC 3: AMS Machine Studio Source information: Name of the logged in user or IP address of the client that initiated the card reboot. Manual change of active/passive state, Reboot

¹ Event number

2 *Number of deleted events*

Index

A

AMS Machine Studio 21, 34, 44
Application 13
ATG-Service 44
Auto discovery 31, 45

B

Basic 29

C

CCC Certification 10
Close editor 29
Configuration editor 24
Configuration offline 21
Configuration online 22
Configuration reload 35
Configuration send 34

D

Device tree 43
Disposal 9

E

ESD 12
Ethernet 18

F

Front view 14

I

Installation 17
IP Address 30

L

LAN 30, 54, 56
License 45

M

Maintenance 59
Mobile App 33, 44
Modbus RTU 44

Modbus TCP/IP 44

N

New 25

O

Online View 43
OPC UA 44

P

Password protection 45
Print configuration 26

R

Redundancy 36
Reload 26
Reset to factory default 26

S

Save & Send 25
Service data 46
Show History/Draft 27
Side view 13
Slot 13

T

Technical support 8

U

USB 18

Emerson

12001 Technology Drive
Eden Prairie, MN 55344 USA
T 1(952)828-3000
www.Emerson.com

Emerson

835 Innovation Drive
Knoxville, TN 37932 USA
T +1 865-675-2400
F +1 865-218-1401
www.Emerson.com

Emerson

Jöbkesweg 3
48599 Gronau
Germany
T +49 2562 709 0
F +49 2562 709 401
www.Emerson.com/ams

©2024, Emerson. All rights reserved.

The contents of this publication are presented for informational purposes only, and while diligent efforts were made to ensure their accuracy, they are not to be construed as warranties or guarantees, express or implied, regarding the products or services described herein or their use or applicability. All sales are governed by our terms and conditions, which are available on request. We reserve the right to modify or improve the designs or specifications of our products at any time without notice.

The Emerson logo is a trademark and service mark of Emerson Electric Co. The AMS logo is a mark of one of the Emerson family of companies. All other marks are the property of their respective owners.

