

Machinery Health™ System

A6500-xR System Racks

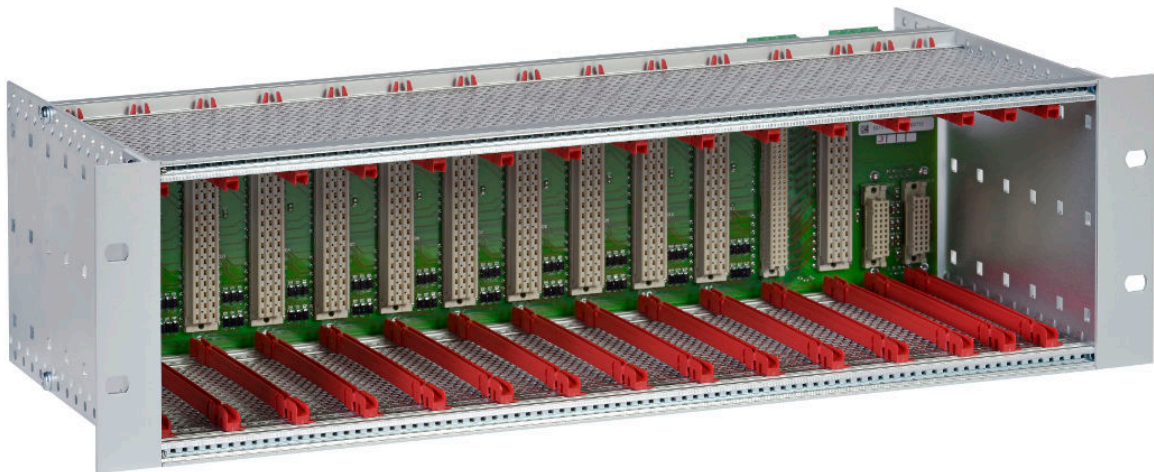

Copyright

© 2024, Emerson. All rights reserved.

No part of this publication may be reproduced, transmitted, transcribed, stored in a retrieval system, or translated into any language in any form by any means without the written permission of Emerson.

Disclaimer

This manual is provided for informational purposes. EMERSON MAKES NO WARRANTY OF ANY KIND WITH REGARD TO THIS MATERIAL, INCLUDING, BUT NOT LIMITED TO, THE IMPLIED WARRANTIES OF MERCHANTABILITY AND FITNESS FOR A PARTICULAR PURPOSE. Emerson shall not be liable for errors, omissions, or inconsistencies that may be contained herein or for incidental or consequential damages in connection with the furnishing, performance, or use of this material. Information in this document is subject to change without notice and does not represent a commitment on the part of Emerson. The information in this manual is not all-inclusive and cannot cover all unique situations.

Patents

The product(s) described in this manual are covered under existing and pending patents.

-  Vermerk zur Installation der Messketten in explosionsgefährdeter Umgebung.
Soll die Messkette in explosionsgefährdeter Umgebung installiert werden, so ist auf die Einhaltung der in der Gebrauchsanweisung enthaltenen Installationshinweise zu achten. Sollten dabei sprachliche Schwierigkeiten auftreten, wenden Sie sich bitte an die Herstellerfirma, sie wird Ihnen eine Übersetzung der relevanten Artikel in der Landessprache des Verwendungslandes zukommen lassen.
-  Nota fuq l-installazzjoni tal-ktajjen tal-kejl f'ambjent esploziv
Jekk il-katina tal-kejl suppost li tigi installata f'ambjent esploziv, hu importanti li ssegwi l-istruzzjonijiet pertinenti tal-manwal. Jekk issib xi diffikultà bil-lingwa, jekk joghgbok ikkuntattja lill-manifattur biex tikseb traduzzjoni tal-paragrafi rilevanti fil-lingwa mehtiega.
-  Anmärkning beträffande installation av mätkedjorna i explosionsfarlig miljö.
Ska mätkedjan installeras i explosionsfarlig miljö, måste de anvisningar följas som ges i instruktionsboken beträffande installationen. Skulle därvid språkproblem uppstå, ber vi dig kontakta det tillverkande företaget som då kommer att sända dig en översättning av de relevanta artiklarna på användningslandets språk.
-  Opomba za namestitve merilne verige v eksplozivno ogroženem okolju
Èe se merilna veriga namešèa v eksplozivno ogroženem okolju, je potrebno upoštevati namestitvena opozorila, ki so v Navodilih za uporabo. Èe se pri tem pojavijo jezikovne težave, se posvetujte z izdelovalcem; poslali vam bodo prevod ustreznih èlankov v jeziku države, kjer se naprava uporablja.
-  Záznam k inštalácii meracích reťazcov vo výbušnom prostredí
Ak má byť merací reťazec inštalovaný vo výbušnom prostredí, treba dbať na dodržiavanie pokynov k inštalácii, uvedených v návode na použitie. V prípade, že by sa pritom vyskytli jazykové problémy, obráťte sa prosím na výrobcu, ktorý Vám zašle preklad relevantných èlánkov v jazyku Vašej krajiny.
-  Nota referente à instalação de cadeias de agrimensur em ambientes potencialmente explosivos
Caso a cadeia de agrimensur deva ser instalada em um ambiente potencialmente explosivo, é imprescindível observar e cumprir as indicações de instalação das instruções de serviço. Caso tenha dificuldades idiomáticas, queira entrar em contato com a firma produtora, esta poderá enviar-lhe uma tradução dos capítulos mais importantes no idioma do país onde o produto deverá ser empregado.
-  Wskazówka dotycząca instalacji łańcuchów mierniczych w otoczeniach zagrożonych eksplozją.
Jeżeli łańcuch mierniczy ma być zainstalowany w otoczeniu zagrożonym eksplozją, należy uwzględnić wskazówki dotyczące instalacji, które są zawarte w instrukcji obsługi. Jeżeli w trakcie lektury wystąpią jakiegokolwiek problemy związane ze zrozumieniem tekstu, prosimy zwrócić się do producenta, który chętnie wykona tłumaczenie wybranych części dokumentacji na język danego kraju.



Opmerking m.b.t. installatie van elektrische meet circuits in explosiegevaarlijke omgeving

Dient de installatie van elektrische meet circuits in een explosiegevaarlijke omgeving te geschieden, moet men toezien dat de in de gebruikshandleiding opgenomen installatieinstructies worden nageleefd. Bij taalkundige problemen gelieve contact op te nemen met de fabrikant, deze zal u vervolgens een vertaling in de taal van het gebruiksland doen toekomen.



Pastaba dėl matavimo grandinės įrengimo sprogimo atžvilgiu pavojingoje aplinkoje

Jei matavimo grandinė turi būti įrengta sprogimo atžvilgiu pavojingoje aplinkoje, privaloma laikytis vartotojo instrukcijoje pateiktų įrengimo nurodymų. Jei kiltų sunkumų dėl kalbos, prašome kreiptis į gamintojo įmonę, kuri pateiks Jums reikiamo skyriaus vertimą į vartotojo valstybės kalbą.



Nota sull'installazione delle catene per misurazione in ambienti a rischio di esplosioni

Nel caso in cui si debbano installare le catene per misurazione in ambienti a rischio di esplosioni, è necessario attenersi alle avvertenze per l'installazione contenute nelle istruzioni d'uso. Per difficoltà di carattere linguistico, rivolgetevi alla ditta produttrice. Quest'ultima Vi farà pervenire una traduzione degli articoli rilevanti nella lingua del paese d'impiego.



Megjegyzés a mérőláncok robbanásveszélyes környezetben történő szereléséhez.

Ha a mérőláncot robbanásveszélyes környezetben kell felszerelni, akkor ügyeljen a Használati útmutatóban közölt szerelési utasítások betartására. Amennyiben nyelvi nehézségek merülnek fel, szíveskedjen a gyártó céghez fordulni, amely elküldni Önnek a felhasználó ország nyelvére lefordított, erre vonatkozó cikket.



Remarque concernant l'installation des chaînes de mesure dans un environnement présentant un risque d'explosion

Si la chaîne de mesure doit être installée dans un environnement présentant un risque d'explosion, il est impératif de veiller à respecter les consignes d'installation contenues dans les instructions de service. S'il devait ce faisant surgir des problèmes linguistiques, veuillez vous adresser à la société fabricante: elle vous fera parvenir une traduction des articles significatifs dans la langue du pays de mise en oeuvre.



Huomautus mittausketjun asentamisesta räjähdysalttiissa ympäristössä

Jos mittausketju tulee asentaa räjähdysalttiissa ympäristössä, on käyttöohjeessa annettuja asennusohjeita noudatettava. Jos käyttöohjeessa käytetty kieli aiheuttaa ongelmia, kääntykää valmistajayrityksen puoleen. Se toimittaa käyttöönnne tarvittavat artikkelit käyttömaan viralliselle kielelle käännettynä.



Juhend mõõdukettide ülespanemiseks plahvatusohtlikus piirkonnas.

Kui panna üles mõõdukettid plahvatusohtlikkus piirkonnas, nii tuleb jälgida kasutusjuhendis sisalduvad instalationimärkmeid. Juhul kui tekkivad raskused keelega, siis pöörduge palun tootja poole. Tootja saadab emakeelse tõlge vastavalt artiklile ning maale.



Notas sobre la instalación de cadenas de medición en un entorno potencialmente explosivo.

Si ha de instalar la cadena de medición en un entorno potencialmente explosivo, deberá respetar las indicaciones sobre la instalación, contenidas en el manual de uso. Si surgieran dificultades lingüísticas, póngase en contacto con la empresa fabricante, que le facilitará una traducción del artículo en la lengua del país donde se emplee.



Note on the installation of the measuring chains in an explosive environment

If the measuring chain is supposed to be installed in an explosive environment, it is important to follow the pertinent installation instructions in the manual. Should you encounter difficulties with the language, please contact the manufacturer to obtain a translation of the relevant paragraphs into the language required.



Σημείωση για την εγκατάσταση αλισιδών μέτρησης σε περιβάλλον, στο οποίο υπάρχει κίνδυνος έκρηξης
Εάν η αλισουδα μέτρησης πρόκειται να εγκατασταθεί σε περιβάλλον, στο οποίο υπάρχει κίνδυνος έκρηξης, πρέπει να τηρηθούν οπωσδήποτε οι οδηγίες εγκατάστασης που περιλαμβάνονται στις οδηγίες Χρήσης. Εάν υπάρχουν γλωσσικές δυσκολίες καταούησης, παρακαλούμε να απευθυνθείτε στην κατασκευάστρια εταιρεία, η οποία θα φρουτίσει για την αποστολή μιας μετάφρασης των σχετικών άρθρων στη γλώσσα της Χώρας Χρήσης.



Info vedrørende installation af målekæderne i eksplosionstruede omgivelser

Hvis målekæden skal installeres i eksplosionstruede omgivelser, skal installationsanvisningerne i brugsanvisningen følges. Hvis der i denne forbindelse opstår sproglige problemer, bedes De henvende Dem til produktionsfirmaet, som så vil sørge for, at De modtager en oversættelse af den relevante artikel på Deres sprog.



Poznámka k instalaci měřicích řetězců v prostředí s nebezpečím výbuchu.

Když má být měřicí řetězec (sestavující z čidla a konvertoru) instalován v prostředí s nebezpečím výbuchu, tak je třeba respektovat instalační pokyny, které jsou součástí návodu k upotřebení. Kdyby při tom došlo k jazykovým potížím, tak prosíme kontaktujte výrobní firmu, která Vám relevantní článek zašle v jazyku krajiny použití.



Piezīme par mērišanas ķēžu instalēšanu sprādziena bīstamās zonās.

Ja mērišanas ķēde jāuzstāda sprādzienbīstamā zonā, ir jāievēro lietošanas instrukcijā dotie instalēšanas norādījumi. Ja rodas kādas valodas grūtības, lūdzu griezieties pie izgatavotāja firmas, kas Jums nosūtīs nozīmīgāko nodaļu tulkojumus lietotāja valsts valodā.

Emerson
epro GmbH
Jöbkesweg 3
48599 Gronau
Germany
T +49 2562 709 0
F +49 2562 709 401
www.Emerson.com

Contents

Chapter 1	General.....	7
	1.1 Using this manual.....	7
	1.2 Symbols.....	7
	1.3 Liability and guarantee.....	8
	1.4 Incoming goods inspection.....	8
	1.5 Technical support.....	8
	1.6 Storage and transport.....	9
	1.7 Disposal of the device.....	9
	1.8 China RoHS Compliance.....	9
	1.9 CCC Certification – AMS 6500 ATG.....	10
	1.10 Installation awareness.....	10
Chapter 2	Safety instructions.....	11
	2.1 Using the device.....	11
	2.2 Owner's responsibility.....	11
	2.3 Radio interference.....	12
	2.4 ESD safety.....	12
Chapter 3	Application and Design.....	13
	3.1 Application.....	13
	3.1.1 A6500-SR System Rack.....	13
	3.1.2 A6500-RR System Rack for redundant Relay Cards.....	14
	3.1.3 A6500-FR System Rack with front terminal connectors	14
	3.2 Design.....	16
	3.2.1 A6500-SR System Rack.....	16
	3.2.2 A6500-RR System Rack for redundant Relay Cards.....	18
	3.2.3 A6500-FR System Rack with front terminal connectors.....	21
Chapter 4	Installation and Mounting.....	25
	4.1 CSA - General safety.....	25
	4.2 Mount the System Rack – A6500-SR and A6500-RR.....	26
	4.2.1 AMS 6500 ATG Fan Kit for A6500-SR.....	27
	4.3 Mount the system rack – A6500-FR.....	28
	4.3.1 AMS 6500 ATG Fan Kit for A6500-FR.....	31
	4.4 Required installation space including cables and ventilation.....	33
	4.5 EMC-compliant installation and grounding example.....	34
	4.6 Connect I/O signals.....	35
	4.6.1 Power supply.....	45
	4.6.2 Connecting sensors to the System Rack.....	48
	4.7 Slide switch settings – digital inputs and key-signals	68

4.7.1	Digital inputs.....	69
4.7.2	Key-signal.....	71
4.8	Communication.....	75
4.8.1	Bus line interconnection of two System Racks.....	76
4.8.2	A6500-FR – Ethernet connection.....	77
4.9	Sensor raw signal.....	78
4.10	Connection of current outputs.....	83
4.11	Digital outputs and Relay Card.....	83
4.12	A6500-RR - external inputs.....	85
4.13	A6500-FR - external inputs.....	86
4.14	Commission the System Rack.....	86
Chapter 5	Hazardous location installation.....	87
5.1	General installation requirements.....	87
5.2	Field housing requirements.....	87
5.3	Connection requirements.....	89
5.4	CSA - Special conditions of safe use.....	89
5.5	Technical data, explosion protection.....	90
5.6	Control drawing – A6500-SR and A6500-RR.....	92
5.7	Control drawing – A6500-FR.....	97
5.8	Revision history.....	102
Chapter 6	Maintenance.....	103
Chapter 7	Replace the System Rack.....	104
Chapter 8	Technical data.....	105
8.1	Power supply.....	105
8.2	Slot distribution.....	105
8.3	Mechanical design and environmental conditions.....	105
Chapter 9	Certificates.....	108

1 General

1.1 Using this manual

This manual contains information concerning the use of the device.

Read the operating manual completely prior to starting installation and operating the device. Comply with all safety instructions.

This operating manual applies for A6500-xR System Racks with hardware revision listed in [Table 1-1](#). See type plate for revision level.

Table 1-1: Hardware revision

A6500-SR System Rack	03, 04, 05, 06, 07
A6500-RR System Rack for redundant Relay Cards	00, 01, 02, 03
A6500-FR Small System Rack with front connectors	02, 03, 04

Include the operating manual when transferring the device to third parties.

Note

When requesting technical support, please indicate type and serial number from the type plate.

[Table 1-2](#) shows a list of documents that are referred to in this operating manual.

Table 1-2: Referenced documents

MHM-97873	Operating Manual A6500-UM Universal Measurement Card
MHM-97874	Operating Manual A6500-TP Temperature Process Card
MHM-97876	Operating Manual A6500-RC Relay Card
MHM-97875	Operating Manual A6500-CC Com Card
MHM-97878	Operating Manual A6500-LC LVDT Converter

1.2 Symbols

Note



This symbol marks passages that contain important information.

⚠ CAUTION

This symbol marks operations that can lead to malfunctions or faulty measurements, but will not damage the device.

⚠ DANGER

A danger indicates actions that can lead to property damage or personal injury.

	According to IEC 61010, this symbol means that this device must be operated with DC voltage.
	According to IEC 61010, this symbol means that the documentation of the device must completely be read and understood before installing and commissioning of the device. Observe all safety related instructions in this document.

1.3 Liability and guarantee

Emerson is not liable for damages that occur due to improper use. Proper use also includes the knowledge of, and compliance with, this document.

Customer changes to the device that have not been expressly approved by Emerson will result in the loss of guarantee.

Due to continuous research and further development, Emerson reserves the right to change technical specifications without notice.

1.4 Incoming goods inspection

Check the content of the shipment to ensure that it is complete, visibly inspect the goods to determine if the device has been damaged during transport. The following parts are included in the scope of delivery and must be contained in the shipment:

- Backplane mounted in a rack
- Cage clamps – only A6500-SR and A6500-RR
- 2HP blind plate, pre-assembled – only A6500-RR
- Short Ethernet cable (approximately 0.5 m) for A6500-CC connection - only A6500-FR
- Operating manual on CD

If the contents are incomplete, or if you observe any defects, file a complaint with the carrier immediately. Inform the responsible Emerson sales organization so your device can be replaced. In this case, attach a tag with customer name and the observed defect.

1.5 Technical support

You may need to ship this product for return, replacement, or repair to an Emerson Product Service Center. Before shipping this product, contact Emerson Product Support to obtain a Return Materials Authorization (RMA) number and receive additional instructions.

Product Support

Emerson provides a variety of ways to reach your Product Support team to get the answers you need when you need them:

Phone Toll free 1 800 833 8314 (U.S. and Canada)
+1 512 832 3774 (Latin America)

+63 2 8702 1111 (Asia Pacific, Europe, and Middle East)

Email Guardian.GSC@Emerson.com

Web <http://www.emerson.com/en-us/contact-us>

To search for documentation, visit <http://www.emerson.com>.

To view toll free numbers for specific countries, visit <http://www.emerson.com/technicalsupport>.

Note

If the equipment has been exposed to a hazardous substance, a Material Safety Data Sheet (MSDS) must be included with the returned materials. An MSDS is required by law to be available to people exposed to specific hazardous substances.

1.6 Storage and transport

Store and transport the device only in its original packaging. Technical data specifies the environmental conditions for storage and transport.

Related information

[Technical data](#)

[Power supply](#)

[Slot distribution](#)

[Mechanical design and environmental conditions](#)

1.7 Disposal of the device

Provided that no repurchase or disposal agreement exists, recycle the following components at appropriate facilities:

- Recyclable metal
- Plastic elements

Sort the remaining components for disposal, based on their condition. National laws or provisions on waste disposal and protection of the environment apply.

Note

Environmental hazards! Electrical waste and electronic components are subject to treatment as special waste and may only be disposed by approved specialized companies.

1.8 China RoHS Compliance

Our products manufactured later than June 30, 2016, and those which are sold in the People's Republic of China are marked with one of the following two logos to indicate the Environmental Friendly Use Period in which it can be used safely under normal operating conditions.

Products that do not have the following marking were either manufactured before June 30, 2026, or are not electrical equipment products (EEP).



Circling arrow symbol with "e": The product contains no hazardous substances over the Maximum Concentration Value and it has an indefinite Environmental Friendly Use Period.



Circling arrow symbol with a number: This product contains certain hazardous substances over the Maximum Concentration Value and it can be used safely under normal operating conditions for the number of years indicated in the symbol. The names and contents of hazardous substances can be found in chapter "Certificates".

1.9 CCC Certification – AMS 6500 ATG

With the announcement of the Chinese market regulation authority SAMR (State Administration for Market Regulation), a Compulsory Product Certification (CCC certification) is mandatory for many explosion protection products. This explosion proof ("Ex") product complies to the CCC obligation and is certified (certification number: 2020322304002386).



This China Compulsory Certificate mark (CCC), is a compulsory safety mark for many products imported, sold, or used in the Chinese market and indicates that the product is certified in accordance to GB/T 3836.1-2021, GB/T 3836.3-2021, and GB/T 3836.8-2021. If the product label is too small to contain the CCC certification mark, it is sufficient to have the mark printed on the minimum package and in the attached document.

1.10 Installation awareness

Note

When planning a measurement, follow these guidelines:

- Consider environmental conditions which might have an influence on the measurement such as temperature, humidity, substances aggressive to the sensor, and pollution.
- Always use a stiff and vibration-free sensor holder.
- Define a suitable measuring range, not larger than necessary, in consultation with the operator of the plant.
- Define the trip limit in consultation with the operator of the plant.
- Take measurement deviations into account when defining trip limits.
- Use a sensor that meets the requirements of the defined measuring range.
- Ensure an EMC-compatible installation including the use of proper cables.
- Ensure proper function of the measurement before activating the measurement in the production environment.

2 Safety instructions

To ensure safe operation, carefully follow all the instructions in this manual.

The correct and safe use of this device requires that operating and service personnel both understand and comply with general safety guidelines and observe the special safety comments listed in this manual. Where necessary, safety-sensitive points on the device are marked.

⚠ DANGER

Because the device is electrical equipment, only specially trained and authorized personnel may commission, service, and maintain this equipment.

2.1 Using the device

Install and use the device as specified in this document.

If the device is used in a manner not specified by the manufacturer, the functions and protection provided by the device may be impaired.

2.2 Owner's responsibility

If there is a reason to suspect that hazard-free operation, and thus, adequate machine protection is no longer possible, take the device out of operation and safeguard it from unintentional operation. This is the case:

- if the device shows visible damage.
- if the device no longer works.
- after any kind of overload that has exceeded the permissible limits (see technical data of the device for permissible limits).

⚠ DANGER

If device tests have to be completed during operation or if the device has to be replaced or decommissioned, it will impair the machine protection and may cause the machine to shut down. Make sure to deactivate machine protection before starting such work, and reactivate it after work has been completed.

Related information

[Technical data](#)

[Power supply](#)

[Slot distribution](#)

[Mechanical design and environmental conditions](#)

2.3 Radio interference

The device is carefully shielded and tested to be technically immune to radio interference and complies with current standards. However, if you operate this device together with other peripheral devices that are not properly shielded against radio interference, disturbances and radio interferences may occur.

2.4 ESD safety

DANGER

Internal components can be damaged or destroyed due to electrostatic discharge (ESD) during the handling of the device.

Take suitable precautions before handling the device to prevent electrostatic discharges through the electronics. Such measures might include, for example, wearing an ESD bracelet. Transport and storage of electronic components may only be made in ESD-safe packaging.



Handle the device with particular care during dry meteorological conditions with relative humidity below 30% as electrostatic discharges can occur more frequently.

3 Application and Design

3.1 Application

Different System Racks are part of the AMS 6500 ATG system. See [Table 3-1](#).

Table 3-1: System Racks

System Rack	Description
A6500-SR 	11 slots for A6500-UM Universal Measurement Cards or A6500-TP Temperature Process Cards
	One slot for an A6500-RC Relay Card
	Two slots for A6500-CC Com Cards
A6500-RR 	Nine slots for A6500-UM Universal Measurement Cards or A6500-TP Temperature Process Cards
	Two slots for A6500-RC Relay Cards
	2HP blind plate already mounted between the A6500-RC Relay Card slots
	Two slots for A6500-CC Com Cards
A6500-FR 	Six slots for A6500-UM Universal Measurement Cards or A6500-TP Temperature Process Cards
	One slot for an A6500-RC Relay Card
	One slot for an A6500-CC Com Card

3.1.1 A6500-SR System Rack

The A6500-SR System Rack is part of the AMS 6500 ATG system. It is a 19" rack (84HP width and 3RU height). The System Rack allows you to install up to 11 protection cards (two channel A6500-UM Universal Measuring Card and/or four channel A6500-TP Temperature Process Card), one A6500-RC Relay Card, and one A6500-CC Com Card – two Com Cards for redundant communication.

The rear of the System Rack is equipped with screw terminal connectors to connect input and output signals, with D-Sub connectors to provide sensor raw signals, and slide switches to configure key signals and binary inputs.

Each of the 11 slots for protection cards has four eight-pole screw terminal connectors for connecting several sensor types (eddy current sensors, piezoelectric sensors, seismic sensors, RTDs, etc.), binary inputs, binary outputs (function outputs), current outputs, and pulse outputs. The available number of measuring channels and all other functions depend on the installed cards.

The function outputs of the protection cards are connected by the backplane of the System Rack to the relay card. The changeover contacts of the 16 output relays are connected to the six eight-pole screw terminal connectors of the Relay Card slot.

The Com Card is required to configure the installed protection cards and provides data using Modbus TCP/IP, Modbus RTU, and OPC UA.

You can extend the system with a second System Rack to a 6RU system. In this case, the Com Card(s) of the first rack are used for both System Racks.

3.1.2 A6500-RR System Rack for redundant Relay Cards

The A6500-RR System Rack for redundant Relay Cards allows you to install two A6500-RC Relay Cards. The inputs of the Relay Cards are connected in parallel to use redundancy. Up to 12 external signals can be connected to the Relay Cards to logically combine them with the internal signals. Because of the second Relay Card, the number of slots for installing protection cards (A6500-UM Universal Measuring Card and/or A6500-TP Temperature Process Card) is limited to nine. All other function and connections of the A6500-RR are identical with the A6500-SR.

Note

A6500-CC Com Cards with firmware version 2.xx support the A6500-RR System Rack.

3.1.3 A6500-FR System Rack with front terminal connectors

The A6500-FR System Rack with front terminal connectors allows you to mount the system rack in boxes or cabinets with no space for connecting cables at the rear. Because of the smaller size than the A6500-SR and A6500-RR 19" racks, the number of slots for installing protection cards (A6500-UM Universal Measuring Card and/or A6500-TP Temperature Process Card) is limited to six. The A6500-FR is designed for one A6500-RC Relay Card and one A6500-CC Com Card. The scope of functions is slightly limited compared to the A6500-SR and A6500-RR System Racks (see [Table 3-2](#))

Note

A6500-CC Com Cards with firmware version 2.xx support the A6500-FR System Rack.

Table 3-2: System Racks - overview differences

Functions / connections	A6500-SR	A6500-RR	A6500-FR
Redundant communication	x	x	-
Redundant A6500-RC Relay Cards	-	x	-
Connection of external alarm signals to the A6500-RC	-	x (12 signals)	x (6 signals)
Connection of a second system rack to the A6500-CC Com Card(s)	x	x	-
Number of slots for A6500-UM and/or A6500-TP	11	9	6
Number of slots for A6500-CC	2	2	1
Number of slots for A6500-RC	1	2	1
Sensor raw through D-Sub connectors	x	x	x
Modbus RTU	x	x	x
Modbus TCP/IP	x	x	x
OPC UA	x	x	x
Cable termination side	rear	rear	front

Table 3-2: System Racks - overview differences (continued)

Functions / connections	A6500-SR	A6500-RR	A6500-FR
Dimensions	3RU/84HP	3RU/84HP	6RU/50HP

3.2 Design

3.2.1 A6500-SR System Rack

Figure 3-1 and Figure 3-2 show the structure of the A6500-SR System Rack backplane.

Figure 3-1: A6500-SR front view

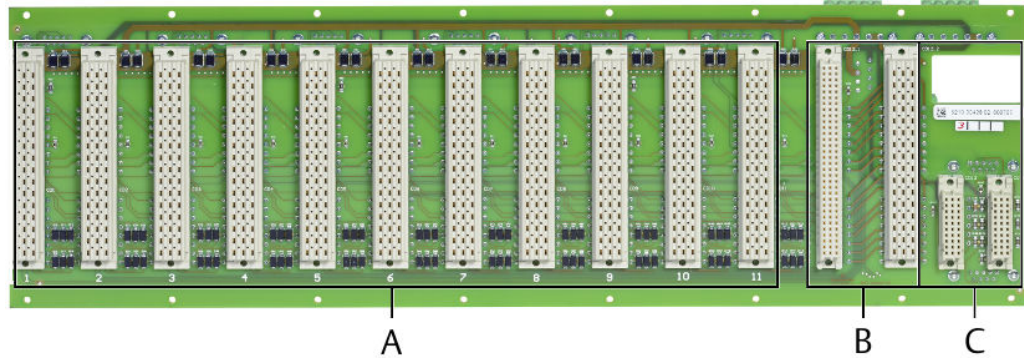

- A. Slots 1 to 11 for Universal Measurement Cards and Temperature Process Cards
- B. Slot for the Relay Card
- C. Slots for Com Cards (one card or two cards for redundant communication)
Left slot: recommended for single card communication and primary card of redundant communication
Right slot: recommended for secondary card of the redundant communication

Figure 3-2: A6500-SR rear view

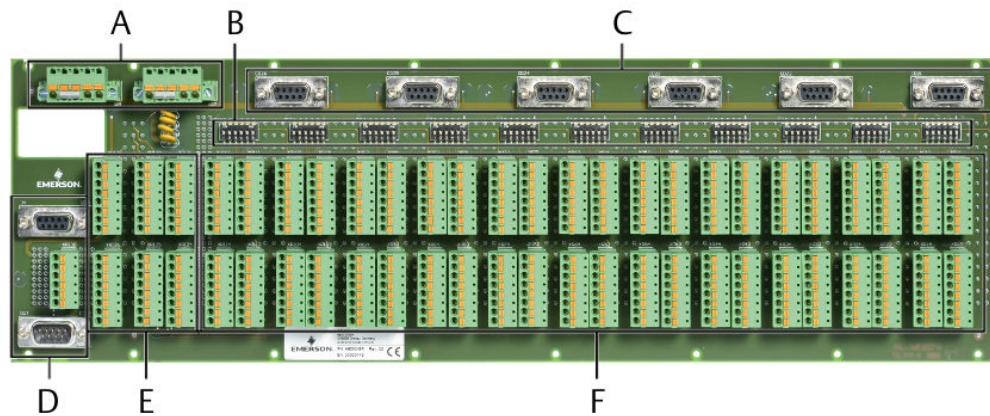

- A. Redundant power supply (+24 V DC).
- B. Slide switches for slots 1 to 11 to assign digital inputs and activate the pulse pull-up voltage.
- C. D-Sub connectors for the sensor raw signals. One connector for four raw signals (two cards with two channels each).
- D. D-Sub connectors for communication in a two-rack system, and 6-pole screw terminal connectors for Modbus RTU communication.¹
- E. Screw terminal connectors to connect the 16 output relays of the Relay Card.¹
- F. Screw terminal connectors to connect to input and output signals of Universal Measuring Cards and Temperature Process Cards.¹

¹ Pictured push-in spring cage connectors are an optional accessory.

3.2.2 A6500-RR System Rack for redundant Relay Cards

Figure 3-3 and Figure 3-5 show the structure of the backplane with redundant relays.

Figure 3-3: A6500-RR front view

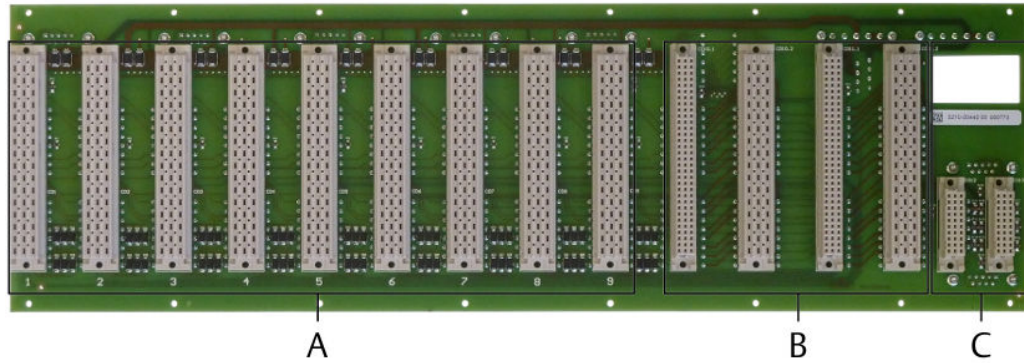

- A. Slots 1 to 9 for Universal Measurement Cards and Temperature Process Cards
- B. Slots for two Relay Cards, separated by a 2HP blind plate (see Figure 3-4 for position)
- C. Slots for Com Cards (one card or two cards for redundant communication)
Left slot: recommended for single card communication and primary card of redundant communication
Right slot: recommended for secondary card of the redundant communication

Figure 3-4: Position 2HP blind plate

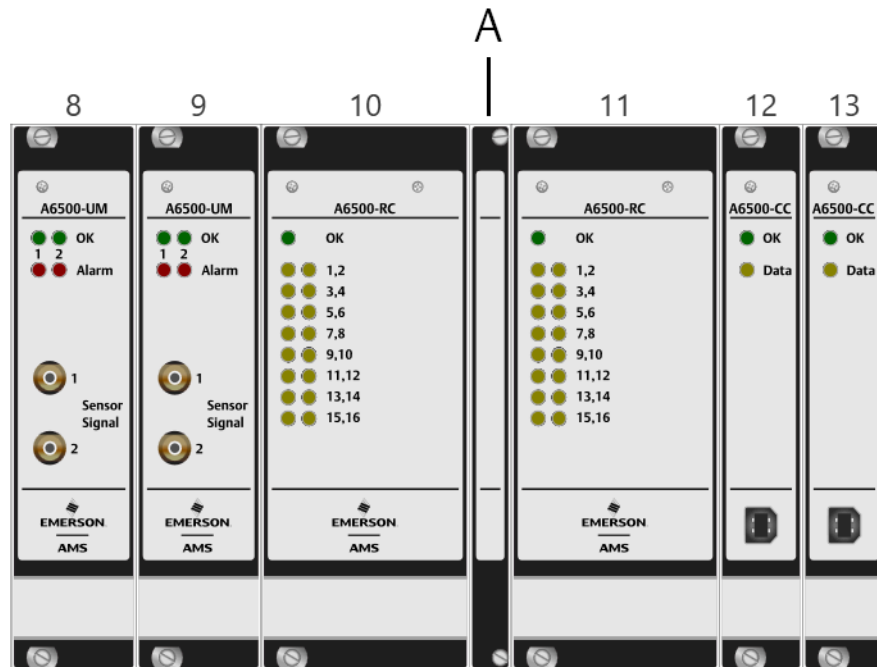

A. 2HP blind plate

Figure 3-5: A6500-RR rear view

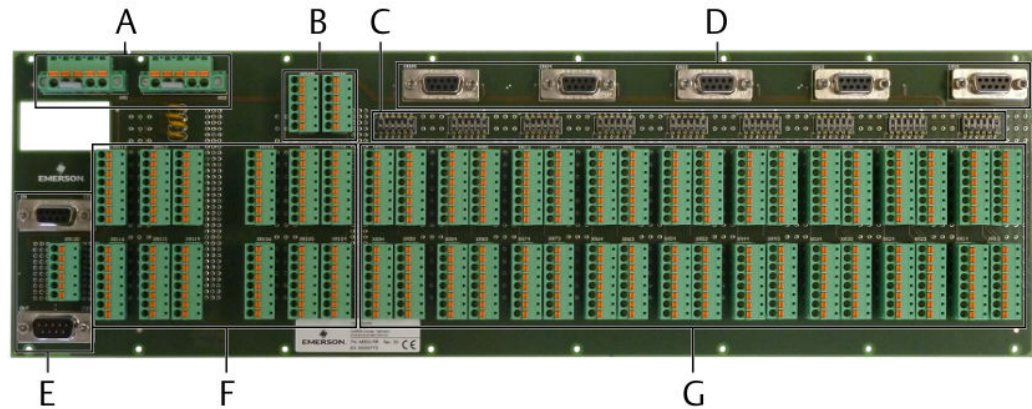

- A. Redundant power supply (+24 V DC).
- B. Screw terminal connectors to connect external signals to the Relay Card.²
- C. Slide switches for slots 1 to 9 to assign digital inputs and activate the pulse pull-up voltage.
- D. D-Sub connectors for the sensor raw signals. One connector for four raw signals (two cards with two channels each).
- E. D-Sub connectors for communication in a two-rack system, and 6-pole screw terminal connectors for Modbus RTU communication.²
- F. Screw terminal connectors to connect the 16 output relays of each Relay Card.²
- G. Screw terminal connectors to connect to input and output signals of Universal Measuring Cards and Temperature Process Cards.²

² Pictured push-in spring cage connectors are an optional accessory.

3.2.3 A6500-FR System Rack with front terminal connectors

[Figure 3-6](#) and [Figure 3-7](#) show the structure of the backplane with front terminal connectors.

Figure 3-6: A6500-FR front view

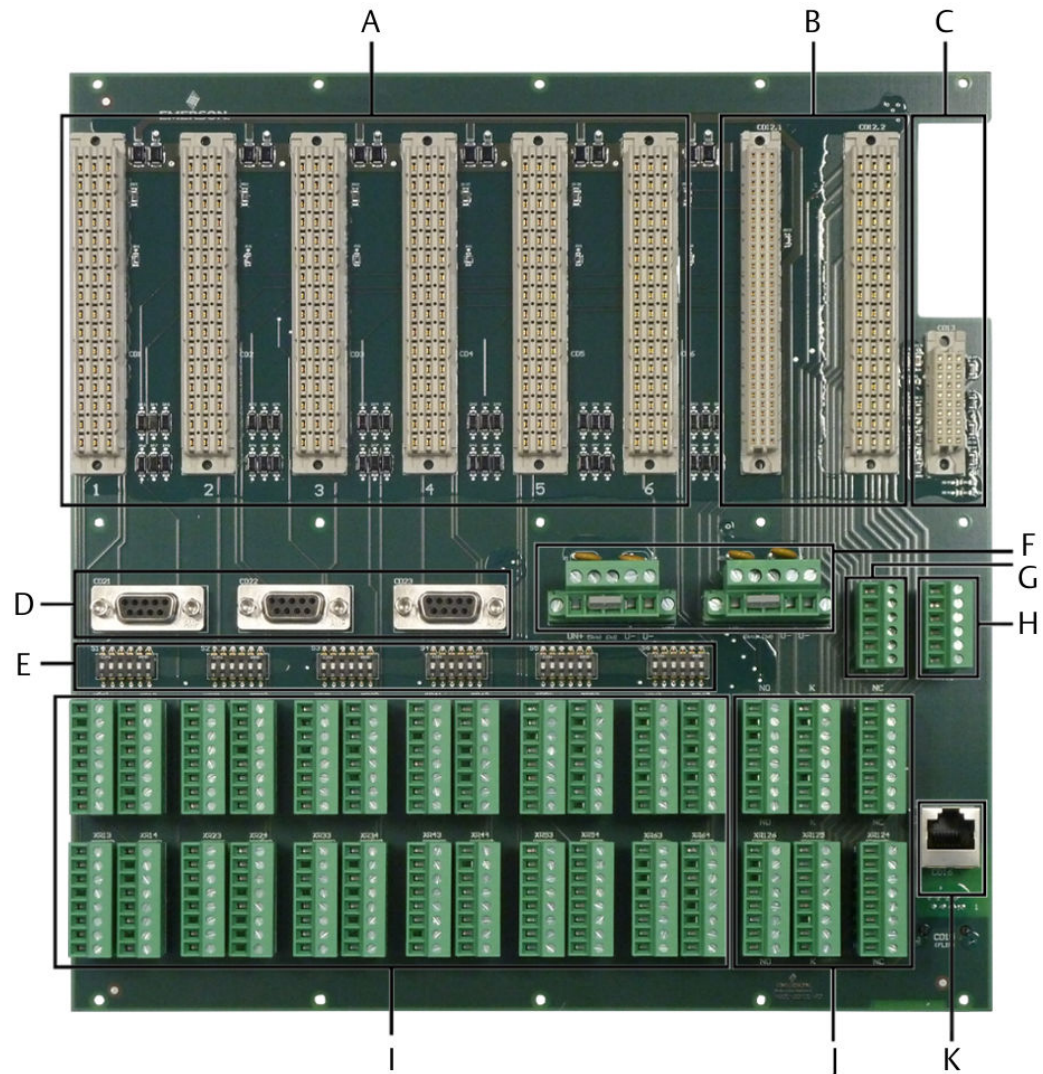

- A. Slots 1 to 6 for Universal Measurement Cards and Temperature Process Cards
- B. Slot for Relay Card
- C. Slot for Com Card with cut-out opening for the Ethernet cable. The Ethernet cable connect to the Com Card passes through this cut-out opening and connects to the RJ45 socket on the rear.
- D. D-Sub connectors for the sensor raw signals. One connector for four raw signals (two cards with two channels each).
- E. Slide switches for slots 1 to 6 to assign digital inputs and activate the pulse pull-up voltage.
- F. Redundant power supply (+24 V DC).
- G. Screw terminal connector for Modbus RTU communication.
- H. Screw terminal connector to connect external signals to the Relay Card.
- I. Screw terminal connectors to connect to input and output signals of Universal Measuring Cards and Temperature Process Cards.

- J. Screw terminal connectors to connect the 16 output relays of the Relay Card.
- K. RJ45 connector to connect an Ethernet to the Com Card. This connector allows you to access the Ethernet signal of the Com Card.

Figure 3-7: A6500-FR rear view

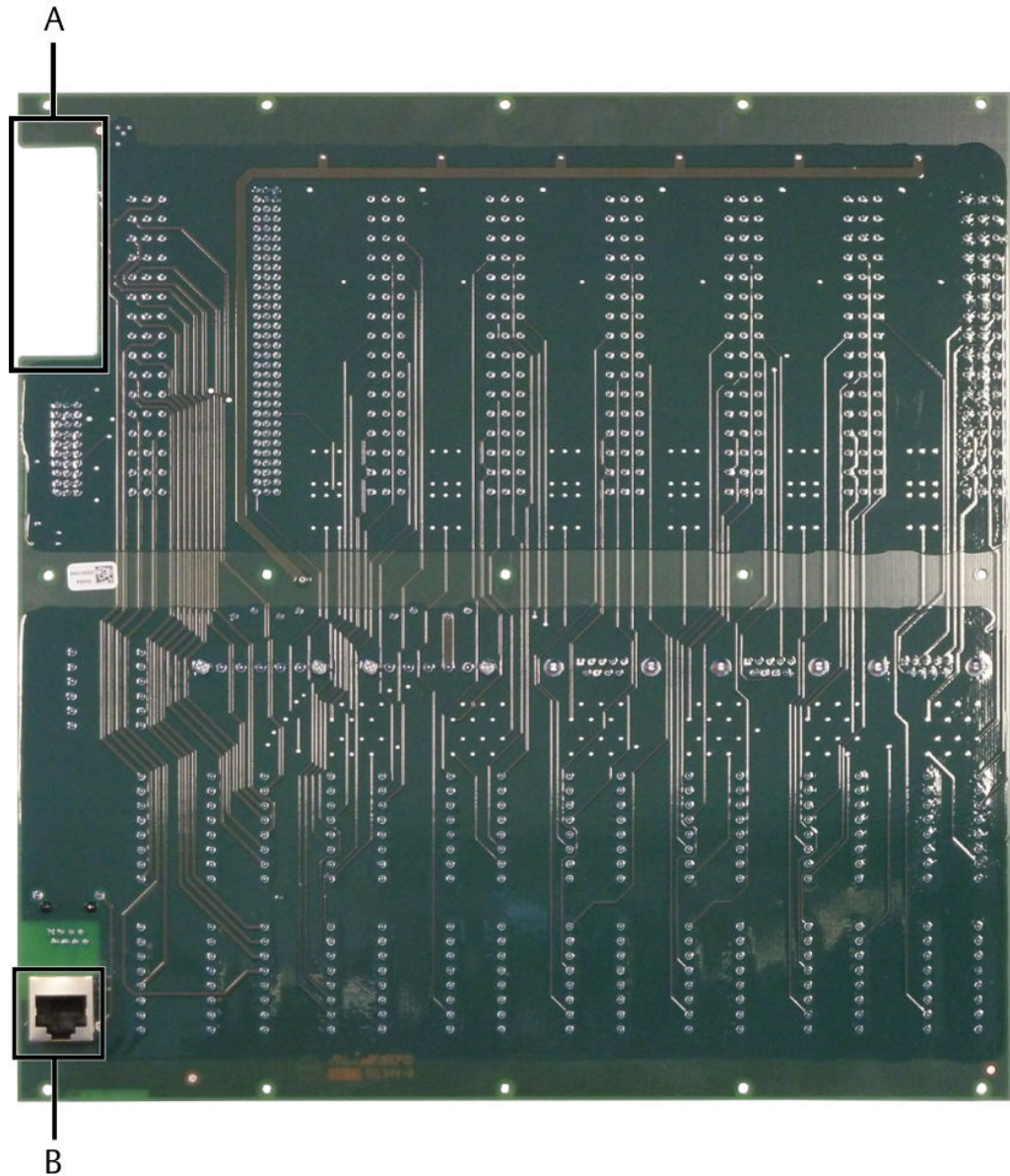

- A. Cut-out opening for the RJ45 socket of the Com Card and the Ethernet cable.
- B. RJ45 socket to forward the Ethernet of the A6500-CC Com Card to the RJ45 socket at the front (see [Figure 3-6](#)) Use the included cable for the Ethernet connection between the Com Card socket and this RJ45 socket.

Figure 3-8 shows the complete A6500-FR System Rack.

Figure 3-8: Front view of the complete A6500-FR System Rack

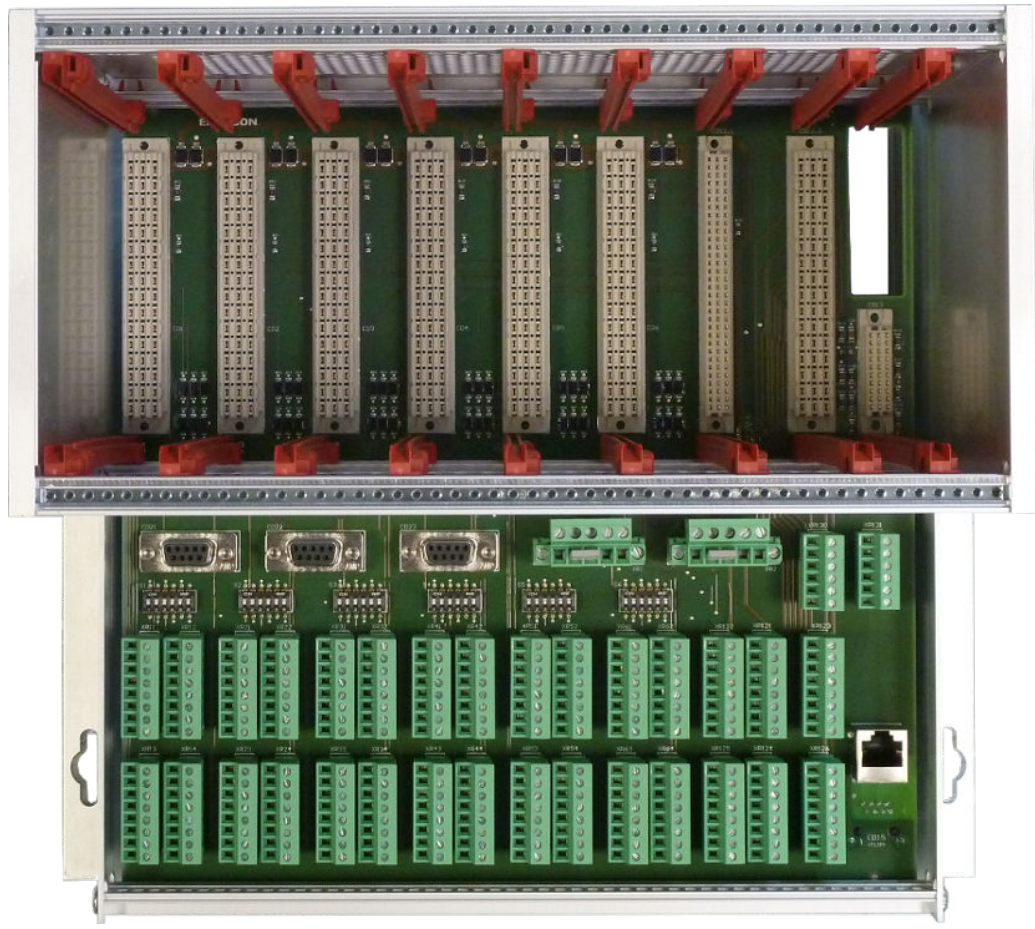

4 Installation and Mounting

4.1 CSA - General safety

Conditions of acceptability

Observe the listed conditions to built-up a system in accordance with the CSA approval:

- A disconnecting device – required by clause 6.11 of IEC 61010-1:2010 – has to be provided, the power supply disconnecting device or interrupt facility may be used.
- The equipment is supplied by a certified power source which is approved in accordance to IEC 60950-1 or IEC 61010-1. The DC output of this separately certified power source shall be below the limits of clause 6.3.1 and 9.4 of IEC 61010-1:2010.
- In combination with a certified external fuse or circuit breaker (see [Power supply](#)) that shall be used with these devices, all devices are considered to fulfill the requirements of a limited energy source to clause 9.4 of IEC 61010-1:2010.
- External circuits of relay card A6500-RC are separated by at least basic insulation. External relay circuits are only intended for connection to voltage levels not exceeding 48 Vac / 2 A or 32 Vdc / 2 A and shall be fused externally to exclude occurrence of higher currents.
- Suitable external cords shall be used in the end application and shall be according to local rules/standards.
- Modules shall be installed within another enclosure, which provides the safety aspects and protects the operator from hazards.
- If at any time there is a conflict between the system safety provisions and any relevant local (national or regional) requirements, the local requirements always take precedence.
- No cooling fan is required for ambient temperatures up to +55 °C. Above ambient temperatures of +55 °C up to +70 °C, a cooling fan is required. This cooling fan shall be separately approved according to relevant local (national or regional) requirements and fulfil the airflow requirements of 440 m³/h.

AMS 6500 ATG Fan Kits

- AMS 6500 ATG Fan Kit for A6500-SR** • The ambient temperature within the end use enclosure shall not exceed 70 °C if a fan tray with three fans and a minimum airflow volume of at least 440 m³/h is mounted directly on the bottom side of the rack.
 - The installation of the AMS 6500 ATG Fan Kit must be verified according to the country-specific regulations.
- AMS 6500 ATG Fan Kit for A6500-FR** • The ambient temperature within the end use enclosure shall not exceed 70 °C if a fan tray with two fans and a minimum airflow volume of at least 300 m³/h is mounted directly on the top side of the rack.

- The installation of the AMS 6500 ATG Fan Kit must be verified according to the country-specific regulations.

4.2 Mount the System Rack – A6500-SR and A6500-RR

The steps below describe the installation of the A6500-SR and A6500-RR System Racks in a cabinet or housing suitable for 19" racks. [Figure 4-1](#) shows an exploded drawing of the AMS 6500 ATG.

Figure 4-1: AMS 6500 ATG exploded drawing

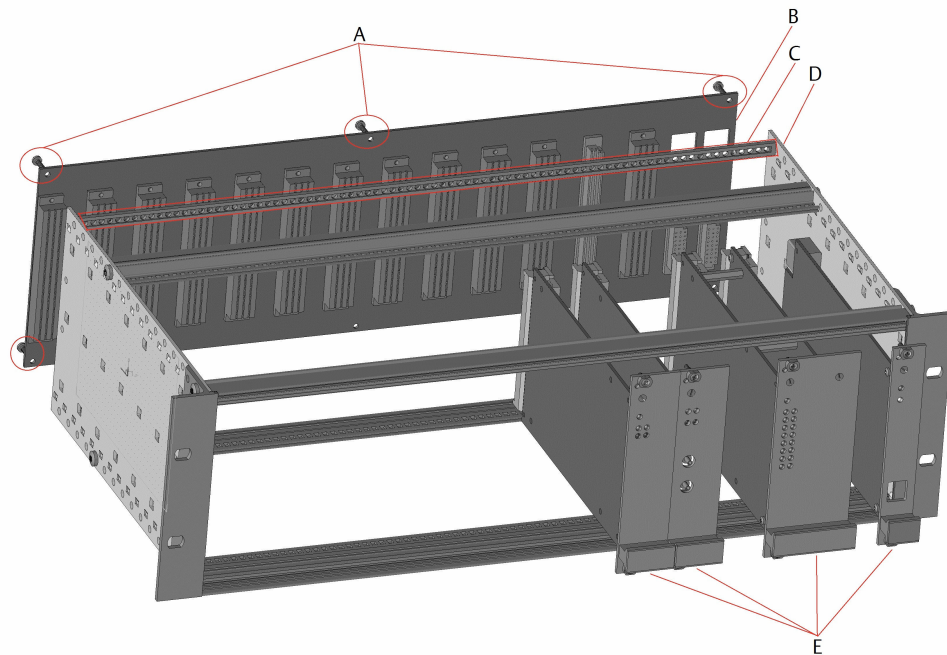

- A. Screws
- B. Backplane
- C. Plastic rail
- D. 19" frame
- E. Cards

Note

Be sure to account for the environmental condition, especially the environmental temperature for the System Rack. Install fan trays or other accommodations if necessary.

Prerequisites

You will need the following equipment to mount the System Rack in a cabinet:

- Suitable Phillips screwdriver for mounting the System Rack with the cage nuts into the cabinet

- Suitable screwdriver for the screw terminal connectors
Recommendation:
Screwdriver 0.4 x 2.5 x 80 mm (Phoenix Contact SZS 0.4X2.5 VDE - 1205037) for the 6-, and 8-pole screw terminal connectors
Screwdriver 0.6 x 3.5 x 100 mm (Phoenix Contact SZS 0.6X3.5 VDE - 1212602) for the 5-pole screw terminal connector

Procedure

1. Mount the System Rack in a suitable housing or cabinet. See [Required installation space including cables and ventilation](#).
2. Connect the sensors, voltage supply, and all other required input and output signals to the System Rack by using the connectors at the rear. See [Connect I/O signals](#).
3. Install the required cards and secure them by tightening the front-plate screws.

4.2.1 AMS 6500 ATG Fan Kit for A6500-SR

The AMS 6500 ATG Fan Kit for A6500-SR (MHM-9199-50009) is an optional accessory to ventilate A6500-SR or A6500-RR System Racks and can be mounted directly at the bottom of these system racks.

Note

Ensure a sufficient space around the fan tray so that the airflow volume of the fans of approximately 440 m³/h is not impaired.

The kit contains the following item:

- Tray with three fans and a push-in spring cage terminal block for connecting the fan supply voltage.
- Six M5x12 screws for mounting the tray (self-cutting screws).

Figure 4-2: A6500-SR with fan tray including terminal block

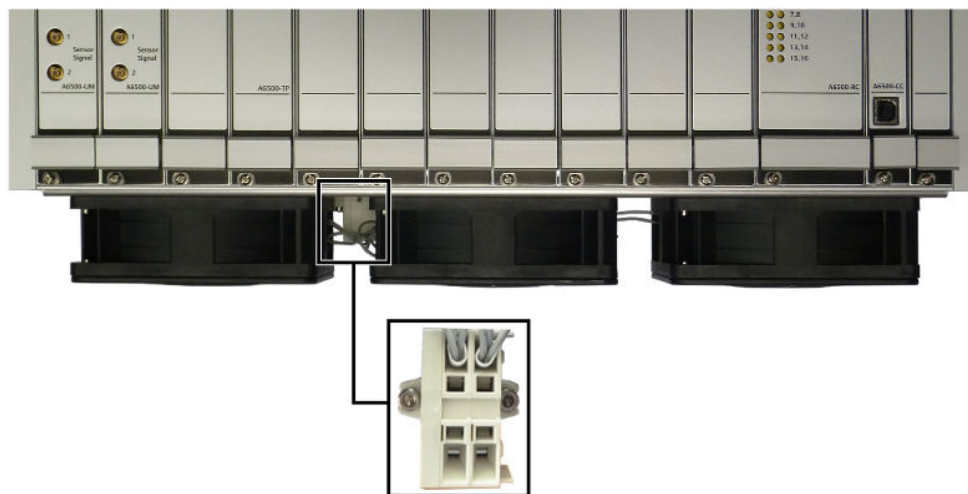

Mounting

Prerequisites

- Suitable screw driver for the M5x12 screws.
- Suitable screw driver for the push-in spring cage terminal block.

Procedure

1. Place the fan tray at the bottom of the A6500-SR or A6500-RR System Rack.
The fan tray fits only in one position.
2. Secure the fan tray with the six self-cutting M5x12 screws.

Figure 4-3: Screws

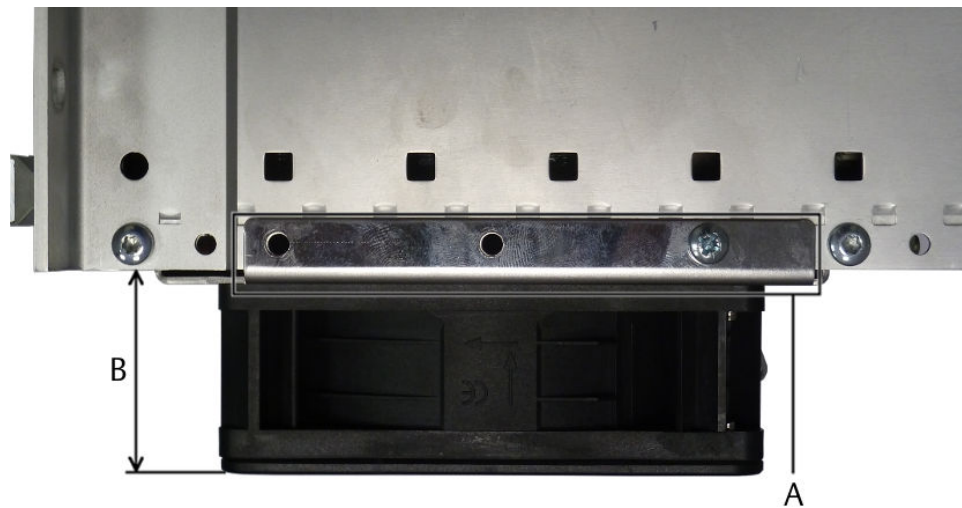

- A. Location of the screw holes. Three on each side of the rack.*
B. Height of the mounted fan tray, approximately 45 mm.

3. Connect a suitable power supply to the fans.

Rated voltage of one fan: 100 V AC to 240 V AC; 50/60 Hz

Rated power of one fan: 3.4 W

For further electrical data of the fans und further installation hints see fan label and operating manual of the fan.

4.3 Mount the system rack – A6500-FR

The steps below describe the installation of the A6500-FR System Rack in a cabinet or housing equipped with a suitable mounting plate.

Note

Be sure to account for the environmental condition, especially the environmental temperature for the System Rack. Install fan trays or other accommodations if necessary.

The minimum recommended cabinet size to use with the A6500-FR is 406.4 mm x 406.4 mm x 304.8 mm (16"x16"x12") assuming external power supplies are used and only A6500-FR is installed inside. A larger cabinet will be needed if power supplies or other equipment are included inside the cabinet.

Circulation fans on the top of the A6500-FR System Rack are recommended whenever there is no other method of air circulation within an enclosed cabinet. If the ambient temperature inside the cabinet adjacent to the System Rack will rise above 40°C at the maximum expected external temperature then fans or other cooling methods must be used. Card temperatures must be kept below 75°C to prevent temperature alerts.

There should be at least 50 mm (2 inches) clear space above the fans or the top of the System Rack to allow air circulation. Field wiring should be routed down, or to the side, from the field connectors and away from the bottom of the card rack. There should be at least 25 mm (1 inch) clear space below the grate on the bottom of the card rack.

Prerequisites

You will need the following equipment to mount the System Rack in a cabinet:

- Four suitable screws for mounting the System Rack on the mounting plate. For example: M6 or UNF 1/4-28 with washer.
- Suitable screwdriver for mounting the System Rack on the mounting plate
- Suitable screwdriver for the screw terminal connectors

Recommendation:

Screwdriver 0.4 x 2.5 x 80 mm (Phoenix Contact SZS 0.4X2.5 VDE - 1205037) for the 6-, and 8-pole screw terminal connectors

Screwdriver 0.6 x 3.5 x 100 mm (Phoenix Contact SZS 0.6X3.5 VDE - 1212602) for the 5-pole screw terminal connector

For dimensions see [Figure 4-4](#) and [Figure 4-5](#).

Figure 4-4: Dimensions

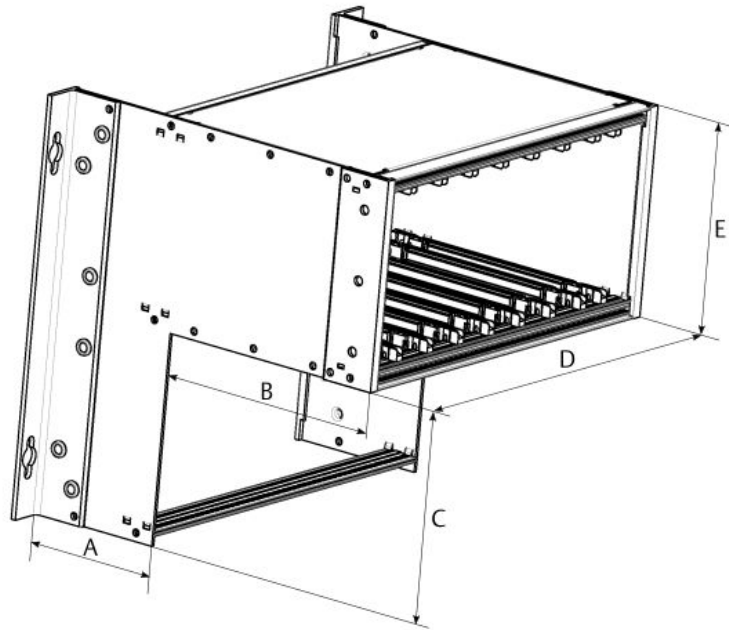

- A. 88.2 mm
- B. 153.5 mm
- C. 133.9 mm
- D. 268.0 mm
- E. 132.5 mm

Prerequisites

Before mounting the System Rack connect the included Ethernet cable. See [A6500-FR – Ethernet connection](#).

Procedure

1. Mount the System Rack through the assembly brackets (see [Figure 4-5](#) for location) on a suitable mounting plate in a housing or cabinet.

Figure 4-5: Assembly brackets

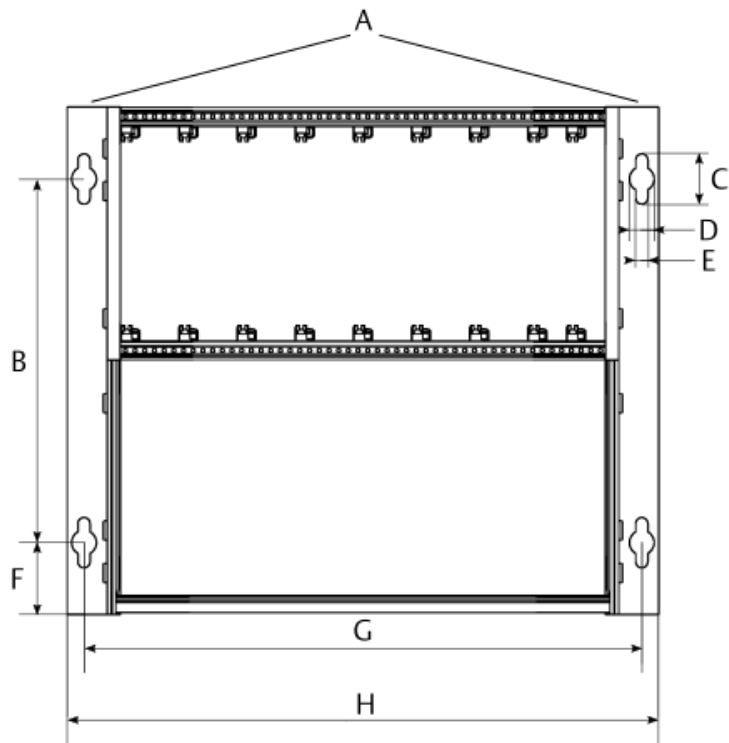

- A. Assembly brackets on the left and right side of the rack.
- B. 190 mm
- C. 26.2 mm
- D. 12.9 mm
- E. 6.3 mm
- F. 37.6 mm
- G. 292.2 mm
- H. 309.8 mm

2. Connect the sensors, voltage supply, and all other required input and output signals to the System Rack by using the screw terminal connectors at the front. See [Connect I/O signals](#).
3. Install the required cards and secure them by tightening the front-plate screws.

4.3.1 AMS 6500 ATG Fan Kit for A6500-FR

The AMS 6500 ATG Fan Kit for A6500-FR (MHM-9199-50010) is an optional accessory to ventilate A6500-FR System Racks and can be mounted directly at the top of the A6500-FR.

Note

Ensure a sufficient space around the fan tray so that the airflow volume of the fans of approximately 300 m³/h is not impaired.

The kit contains the following items:

- Tray with two fans.
- Push-in spring cage terminal block for connecting the fan supply voltage.
- Two 3x10 A2 screws for the terminal block mounting.
- Two ferrules.
- Six M5x12 screws for mounting the tray at to top of the A6500-FR (self-cutting screws).
- Two M4x16 screws with two M4 self-locking nuts for mounting the tray.

Figure 4-6: A6500-FR with fan tray



Mounting

Prerequisites

- Suitable screw driver for the M5x12 screws.
- Suitable screw driver for the M4x16 screws.
- Suitable spanner (wrench) for the M4 nuts.
- Suitable screw driver for the 3x10 A2 screws.
- Suitable screw driver for the push-in spring cage terminal block.
- Crimper for the ferrules.

Procedure

1. Place the fan tray at the top of the A6500-FR System Rack.
The fan tray only fits in one position.
2. Secure the fan tray with the six self-cutting M5x12 screws and the two M4x16 screws with the self-locking M4 nuts.

Figure 4-7: Screw hole location and fan tray height

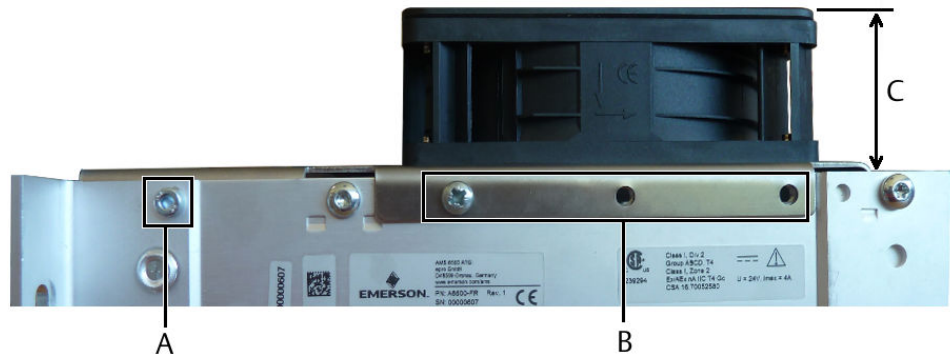

- A. Location of the screw hole for the M4x16 screw. One on each side of the rack.
- B. Location of the screw holes for the M5x12 screws. Three on each side of the rack.
- C. Height of the mounted fan tray, approximately 45 mm.

3. Strip off the isolation of the connection wires.
Stripping length approximately 8 mm.
4. Insert one stripped wire of each fan into one ferrule, and crimp the ferrule. Repeat this for the two remaining wires.
Two stripped wires fit into one of the included ferrules.
5. Find a suitable location to place the terminal block. Use the included 3x10 A2 screws or other screw types if the included screws are not suitable for the mounting surface.
6. Connect the wires with the terminal block.
7. Connect a suitable power supply to the fans.
Rated voltage of one fan: 100 V AC to 240 V AC; 50/60 Hz
Rated power of one fan: 3.4 W
For further electrical data of the fans and further installation hints, see fan label and operating manual of the fan.

4.4 Required installation space including cables and ventilation

When installing A6500-SR or A6500-RR System Racks, provide a minimum cable installation space of 100 mm x 438.6 mm x 132.5 mm, as shown in [Figure 4-8](#).

Figure 4-8: 19" System Rack mounting space

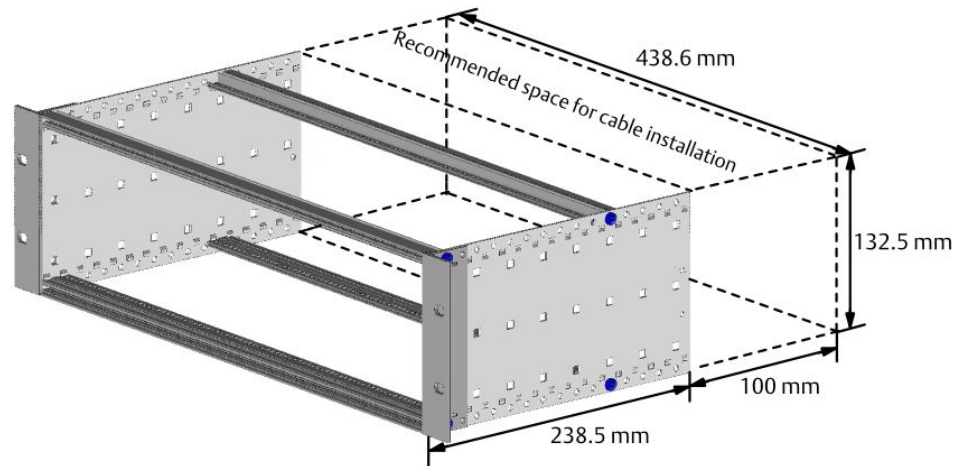

The following requirements apply to all System Racks:

You must provide an adequate ventilation space so that heat does not build up. The ventilation space must be at least 1RU (1.75 inch; 44.45 mm) in all directions. If the ambient temperature of the rack rises above 55°C, cool this instrument with a forced air fan, cooler, or something similar.

When mounting several units above each other in one cabinet, install cooling fan racks in between instead of leaving ventilation space. The necessary specifications for cooling fan racks result from where and how the cabinet is installed and therefore cannot be defined specifically.

The maximum operating temperature of devices of the AMS 6500 ATG is 70°C. Use cables designed for such conditions.

4.5 EMC-compliant installation and grounding example

For an EMC-compliant installation ensure:

- The system is installed in a suitable housing or cabinet.
- The signal cable shields must be connected to ground at the cable inlet of housing or cabinet. See [Figure 4-9](#) for grounding concept.
- Electrical connections use shielded cables.

Figure 4-9: Example grounding concept

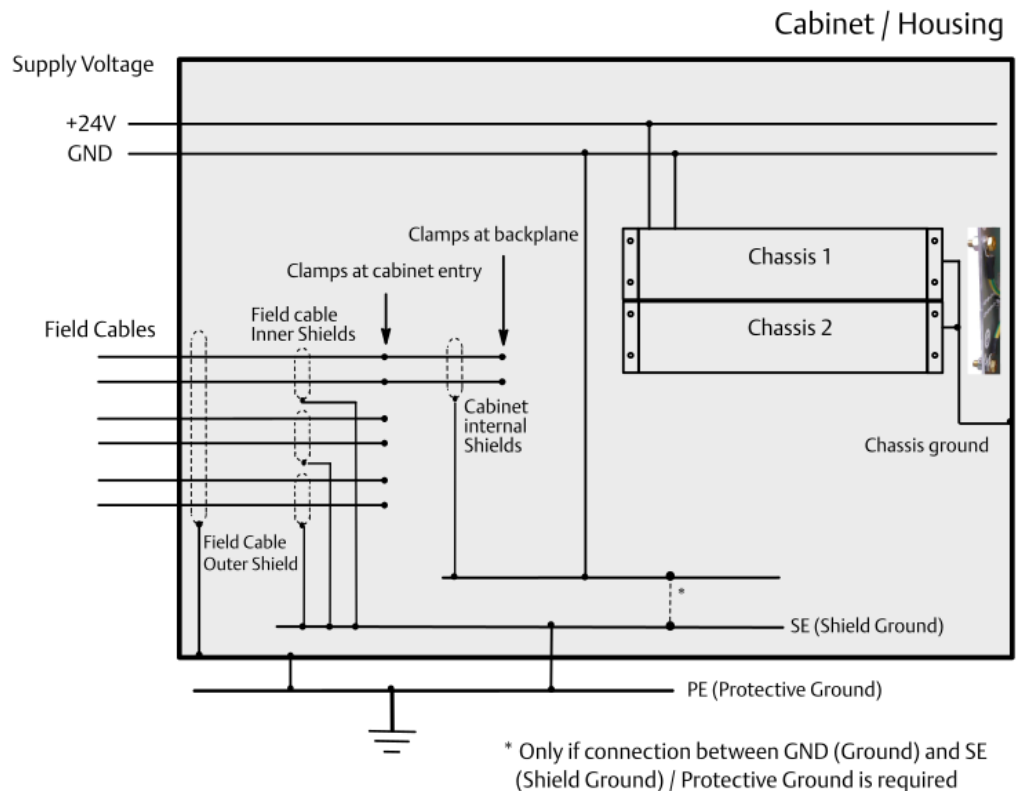

The diagram above shows a grounding example. The actual grounding concept depends on the on-site conditions. The following connections are made in this example:

- Outer shield of field / signal cables are connected at the cabinet inlet to PE (Protective Ground) by a connection to the cabinet.
- Inner shields of field / signal cables are connected to SE (Shield Ground).
- Cable shields used within the cabinet are connected to GND rail.
- Cabinet is connected to PE.
- Chassis are connected to PE by a connection to the cabinet.

By grounding as shown, field shields are connected at the cabinet inlet, so that disturbances do not affect the entire cabinet.

When connecting sensor signals, Emerson recommends LiYCY-CY cables.

4.6 Connect I/O signals

The connections of the input and output signals as well as the voltage supply is made by 5-, 6-, and 8-pole screw terminal connectors. The permitted wire cross-section for these terminals are shown in [Table 4-1](#) and [Table 4-3](#).

Push-in spring cage connectors are an optional accessory. See [Table 4-2](#) and [Table 4-4](#) for permitted cross-sections for the spring cage connectors.

Table 4-1: 5-pole supply voltage screw terminal connectors

Wire description	Wire cross-section	
	Minimum	Maximum
Conductor cross section solid	0.34 mm ²	2.5 mm ²
Conductor cross section stranded	0.2 mm ²	2.5 mm ²
Conductor cross section stranded, with ferrule without plastic sleeve	0.25 mm ²	2.5 mm ²
Conductor cross section stranded, with ferrule with plastic sleeve	0.25 mm ²	2.5 mm ²
Conductor cross section AWG/kcmil	24	12
2 conductors with same cross section, solid	0.2 mm ²	1.5 mm ²
2 conductors with same cross section, stranded	0.2 mm ²	1.5 mm ²
2 conductors with same cross section, stranded, with ferrules without plastic sleeve	0.25 mm ²	1.0 mm ²
2 conductors with same cross section, stranded, TWIN ferrules with plastic sleeve	0.5 mm ²	1.0 mm ²
AWG according to UL/CUL	30	12

- Required stripped length of wire: 10 mm.
- Tightening torque: minimum 0.5 Nm and maximum 0.6 Nm.
- Flat head screwdriver is required.

Table 4-2: 5-pole supply voltage spring cage connector

Wire description	Wire cross-section	
	Minimum	Maximum
Conductor cross section solid and stranded	0.2 mm ²	2.5 mm ²
Conductor cross section stranded, with ferrule without plastic sleeve	0.25 mm ²	2.5 mm ²
Conductor cross section stranded, with ferrule with plastic sleeve	0.25 mm ²	2.5 mm ²
Conductor cross section AWG/kcmil	24	12
2 conductors with same cross section, solid	0.2 mm ²	1.5 mm ²
2 conductors with same cross section, stranded	0.2 mm ²	1.5 mm ²
2 conductors with same cross section, stranded, TWIN ferrules with plastic sleeve	0.5 mm ²	1.0 mm ²
AWG according to UL/CUL	26	12

- Required stripped length of wire: 10 mm.
- Flat head screwdriver is required for disconnecting wires.

Table 4-3: 6- and 8-pole screw terminal connectors

Wire description	Wire cross-section	
	Minimum	Maximum
Conductor cross section solid and stranded	0.14 mm ²	1.5 mm ²
Conductor cross section stranded, with ferrule without plastic sleeve	0.25 mm ²	1.5 mm ²
Conductor cross section stranded, with ferrule with plastic sleeve	0.25 mm ²	0.5 mm ²
Conductor cross section AWG/kcmil	28	16
2 conductors with same cross section, solid	0.14 mm ²	0.5 mm ²
2 conductors with same cross section, stranded	0.14 mm ²	0.75 mm ²
2 conductors with same cross section, stranded, ferrules without plastic sleeve	0.25 mm ²	0.35 mm ²
2 conductors with same cross section, stranded, TWIN ferrules with plastic sleeve	0.5 mm ²	0.5 mm ²
AWG according to UL/CUL	30	16

- Required stripped length of wire: 9 mm.
- Tightening torque: minimum 0.22 Nm and maximum 0.25 Nm.
- Flat head screwdriver is required.

Table 4-4: 6- and 8-pole spring cage connectors

Wire description	Wire cross-section	
	Minimum	Maximum
Conductor cross section solid and stranded	0.14 mm ²	1.5 mm ²
Conductor cross section stranded, with ferrule without plastic sleeve ¹	0.25 mm ²	1.5 mm ²
Conductor cross section stranded, with ferrule with plastic sleeve ¹	0.25 mm ²	0.5 mm ²
Conductor cross section AWG/kcmil	26	16
2 conductors with same cross section, stranded, ferrules without plastic sleeve ¹	0.14 mm ²	0.75 mm ²
2 conductors with same cross section, stranded, TWIN ferrules with plastic sleeve ¹	0.14 mm ²	0.5 mm ²
AWG according to UL/CUL	28	16

¹ Stripped length of wire: 10mm

- Required stripped length of wire: 9 mm.
- Flat-head screwdriver is required for disconnecting wires.

Pin assignment

The following figures show an overview of the connection terminals of the System Racks.

Note

The position of the connectors depends on the System Rack used. The pin assignment of the connectors is identical for all System Racks.

When viewing the connectors on the A6500-SR and A6500-RR System Racks, the connectors are counted from right to left (see [Figure 4-10](#)).

Figure 4-10: A6500-SR and A6500-RR rear connectors counting direction: right to left

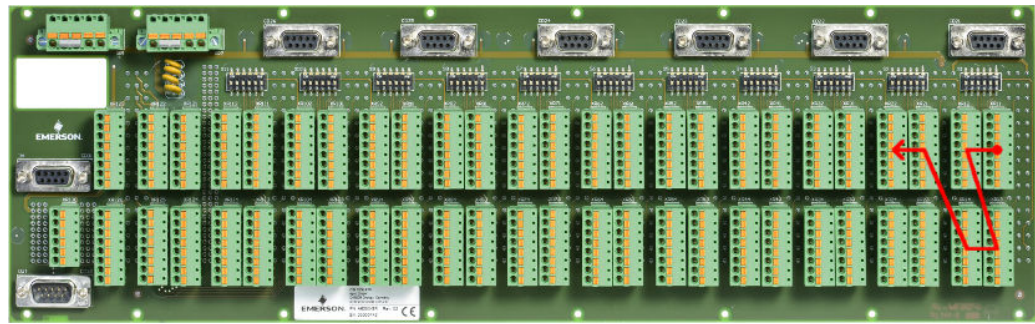

When viewing the connectors on the A6500-FR System Rack, the connectors are counted from left to right (see [Figure 4-11](#)).

Figure 4-11: A6500-F front connectors counting direction: left to right

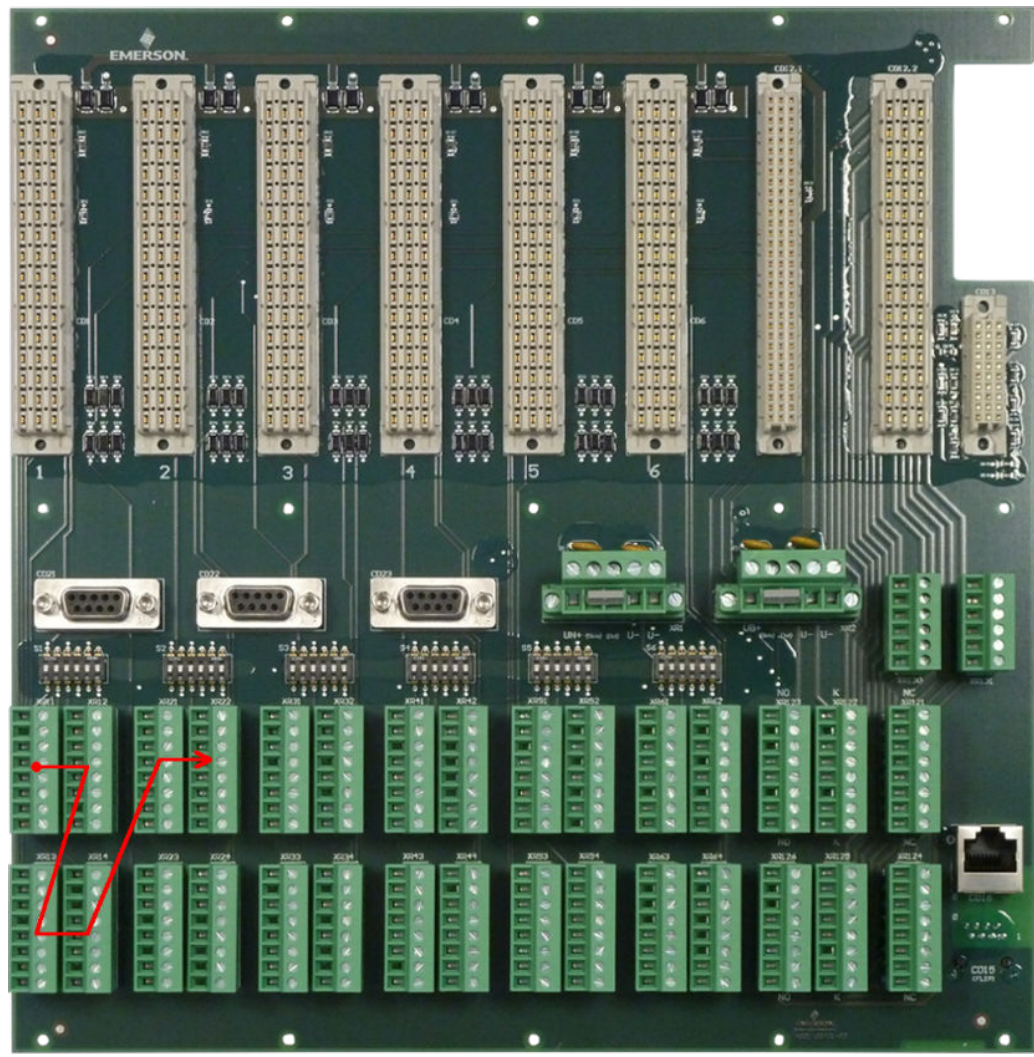

Pin assignment card slot

Figure 4-12 and Figure 4-13 show the pin assignment of the protection card slots if you use a two-channel Universal Measurement Card. Figure 4-14 and Figure 4-15 show pin assignments if a four-channel Temperature Process Card is used. Each slot has four 8-pole screw terminal connectors XR_x1 to XR_x4, where x refers to the slot number.

Figure 4-12: A6500-SR and A6500-RR – Pin assignment slot with Universal Measurement Card

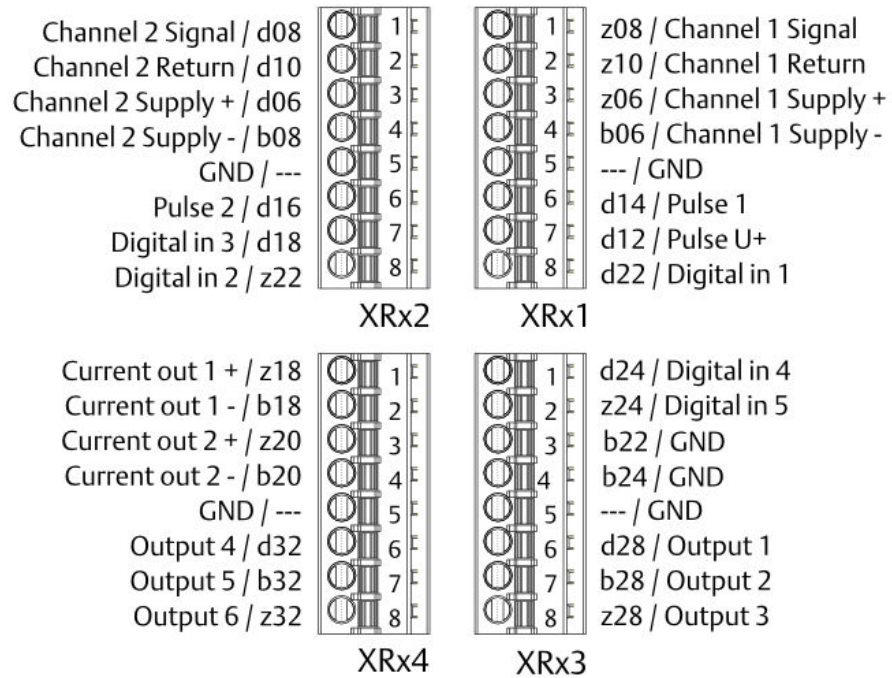

A6500-SR: Slots 1 to 11

A6500-RR: Slots 1 to 9

Figure 4-13: A6500-FR – pin assignment slot with Universal Measurement Card

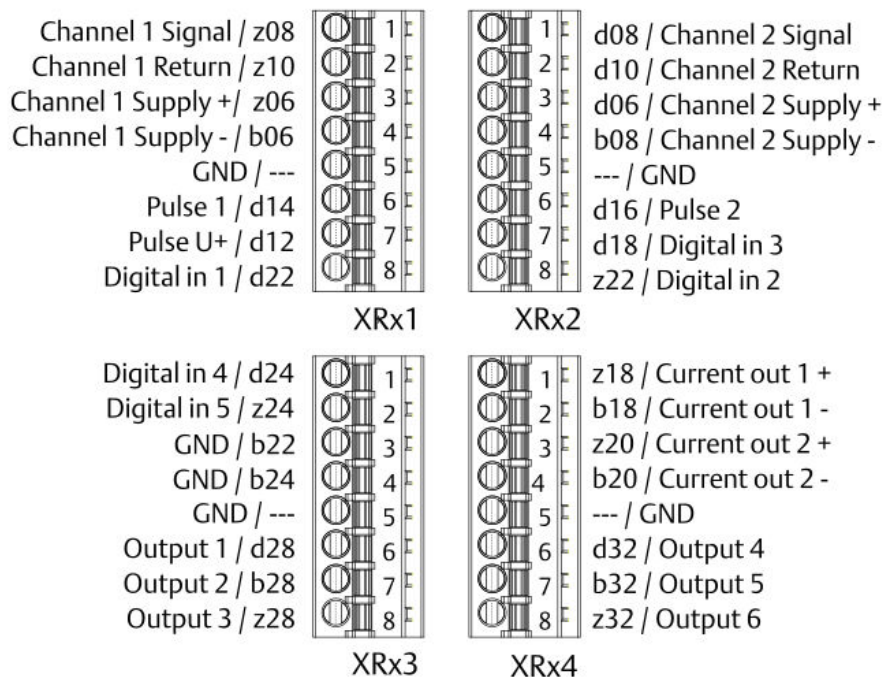

A6500-FR: Slots 1 to 6

Figure 4-14: A6500-SR and A6500-RR – pin assignment slot with Temperature Process Card

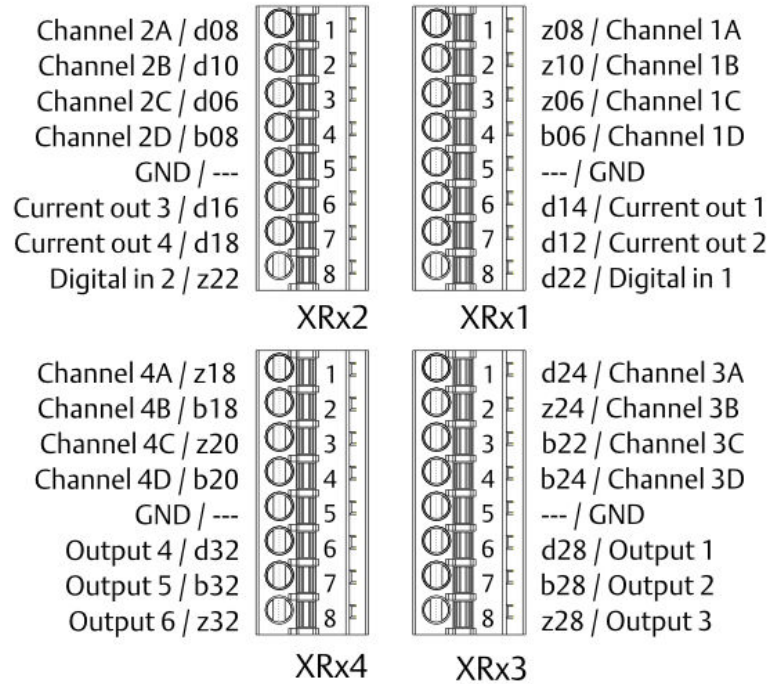

A6500-SR: Slots 1 to 11

A6500-RR: Slots 1 to 9

Figure 4-15: A6500-FR – pin assignment slot with Temperature Process Card

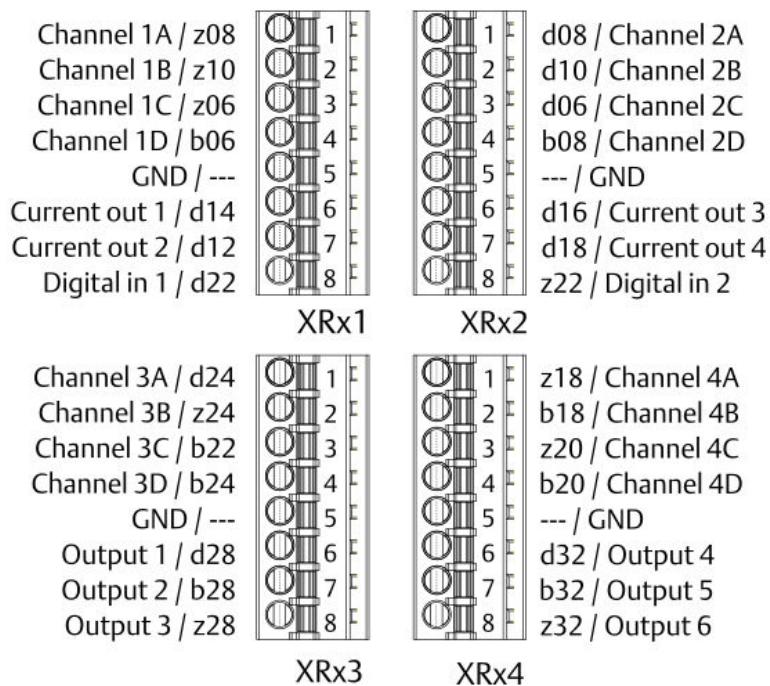

A6500-FR: Slots 1 to 6

Pin assignment Relay Card slot

Figure 4-16 shows the pin assignment of the Relay Card slot. Each slot has six 8-pole screw terminal connectors. See Table 4-5 for connector numbering depending on the System Rack used.

Table 4-5: Connector numbering

System Rack		Screw terminal connectors
A6500-RR	first Relay Card	XR101 to XR106
	second Relay Card	XR111 to XR116
A6500-SR and A6500-FR		XR121 to XR126

Figure 4-16: Pin assignment Relay Card

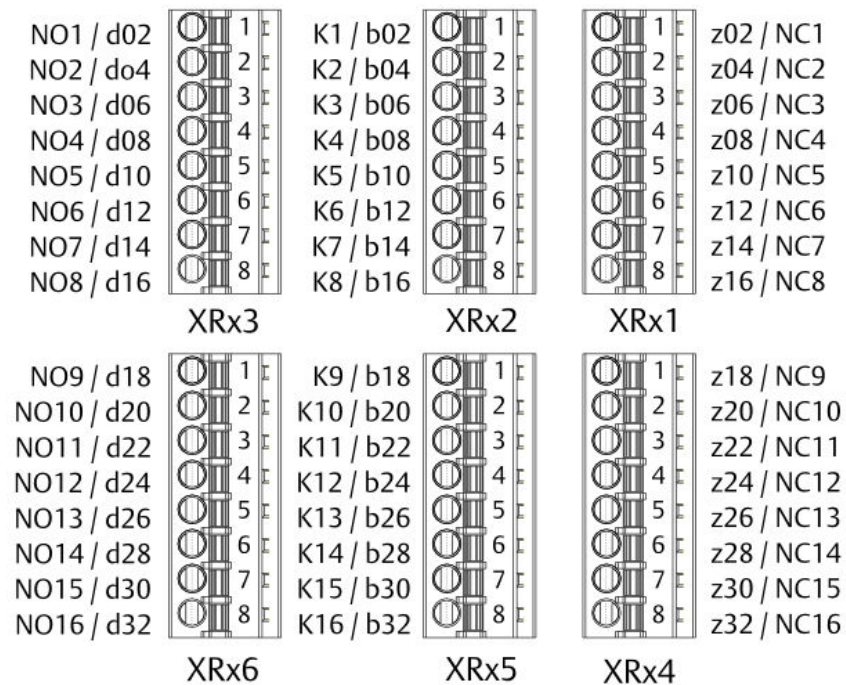

x = slot number 10 (A6500-RR, first Relay Card), 11 (A6500-RR, second Relay Card), or 12 (A6500-SR and A6500-FR)

Pin assignment Com Card slot

Figure 4-17 and Figure 4-18 show the pin assignment of the 6-pole screw terminal connector for the Modbus RTU connection. On the A6500-SR and A6500-RR System Racks, this connector is assigned to both Com Card slots. The A6500-FR has only one Com Card slot.

Figure 4-17: Pin assignment Com Card slot A6500-SR and A6500-RR

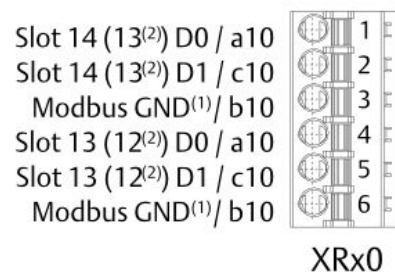

(1) Modbus GND is galvanically separated from the system GND.

(2) A6500-RR

x = 12 (A6500-RR) or 13 (A6500-SR)

Figure 4-18: Pin assignment Com Card slot A6500-FR

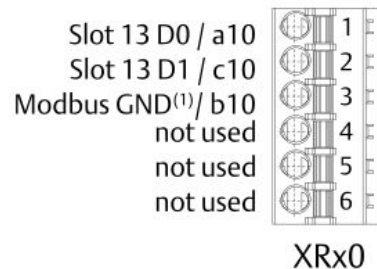

(1) Modbus GND is galvanically separated from the system GND.

x = 13

Pin Assignment supply voltage connection

Figure 4-19 shows the pin assignment of both 5-pole screw terminal connectors XR1 and XR2 of the redundant supply voltage connection.

Figure 4-19: Pin assignment supply voltage connection

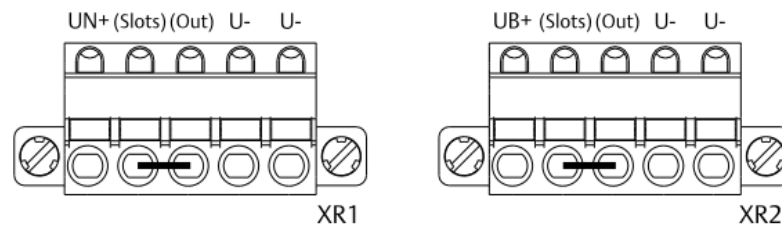

4.6.1 Power supply

The AMS 6500 ATG system must be supplied with safety extra-low voltage (24 V). A power supply unit is required that meets IEC 60950-1 (SELV) or IEC 60204-1 (PELV). The required voltage maximum is 32.0 V DC with a limited energy (see [Power supply](#)). All external devices connected to the AMS 6500 ATG system must also meet these requirements. External voltages on inputs and outputs driven by external devices must not exceed the level of IEC60204-1 or IEC61131-2 in case of a single failure.

The System Racks have two supply voltage connectors. XR1 is for single supply of the backplane. All cards (Universal Measuring Cards, Temperature Process Cards, Relay Card, and Com Cards) and the digital outputs of the System Racks can be supplied separately. XR2 is for the redundant supply of the System Racks. [Figure 4-20](#) to [Figure 4-23](#) show the different voltage supply options. The terminal for the card supply is designated with (Slots) and the terminal for the digital output supply is designated with (Out). In delivery state, a bridge is installed between the terminals (Slots) and (Out). This bridge must be removed if cards and binary outputs will be supplied separately.

Figure 4-20: Voltage supply option - one supply

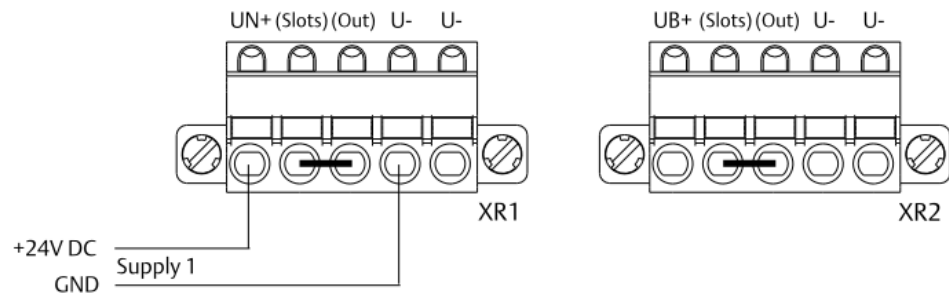

One supply for card slots (Slots) and digital outputs (Out).

Figure 4-21: Voltage supply option - two supplies, separate

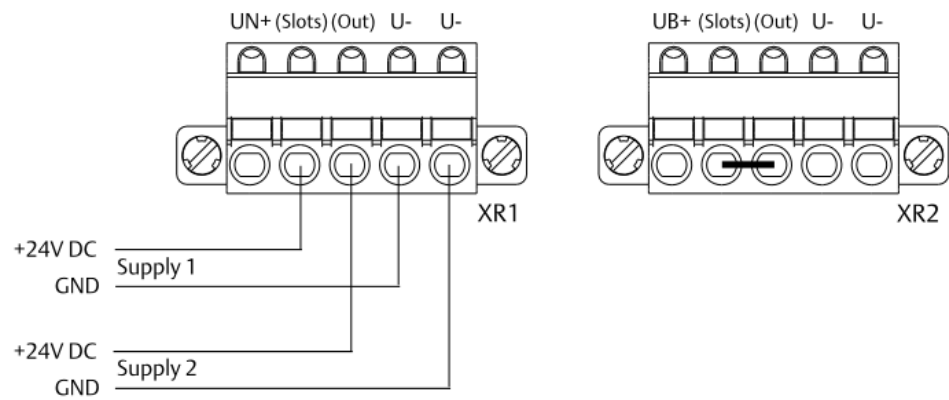

Two power supplies for separate supply of card slots (Slots) and digital outputs (Out).

Figure 4-22: Voltage supply option - two supplies, redundant supply

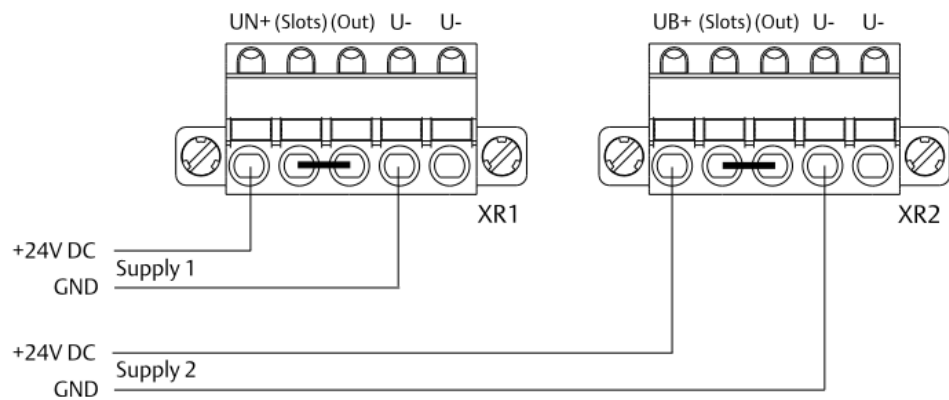

Two power supplies for redundant supply of card slots (Slots) and digital outputs (Out) without supply separation of slots and outputs.

Figure 4-23: Voltage supply option - four supplies, redundant and separate

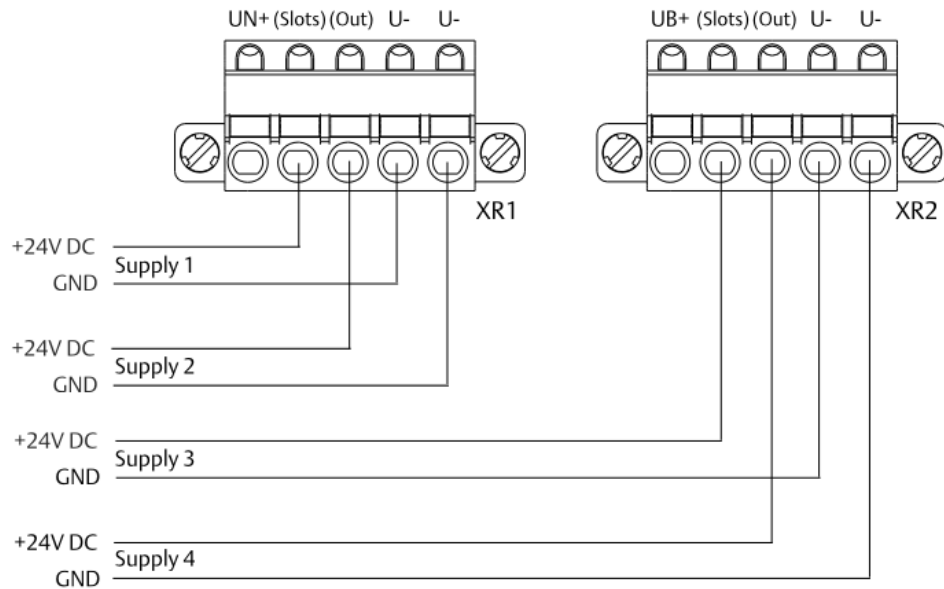

Four power supplies for redundant and separate supply of card slots (Slots) and digital outputs (Out).

Fuse protection

To meet IEC 61010-1, supply the AMS 6500 ATG with a limited energy source which must be clearly labeled and switchable. Use special power supplies (NEC Class 2 compliant) or a pre-fuse for each supply terminal to limit the energy to each of the connected supply terminals UN+ (Slot), UN+ (Out), UB+ (Slot), and UB+ (Out). According to IEC 61010-1, the total current of each supply terminal shall never exceed $I_{max} = 200 \text{ W/U}$ after 120 seconds. Emerson recommends using fuses with ON/OFF functionality to provide a switchable energy source.

How to define a suitable pre-fuse

The procedure is described with a supply voltage of 24.0 V and the circuit breaker family 1180-01 (E-T-A).

1. Calculate the maximum allowed current.

$$I_{max} = 200 \text{ W/U} = 200 \text{ W} / 24 \text{ V} = 8.33 \text{ A}$$
2. Find the multiple of the rated current for 120 seconds in the data sheet of the fuse intended for use (for example see [Figure 4-24](#)).

Figure 4-24: Rated current diagram

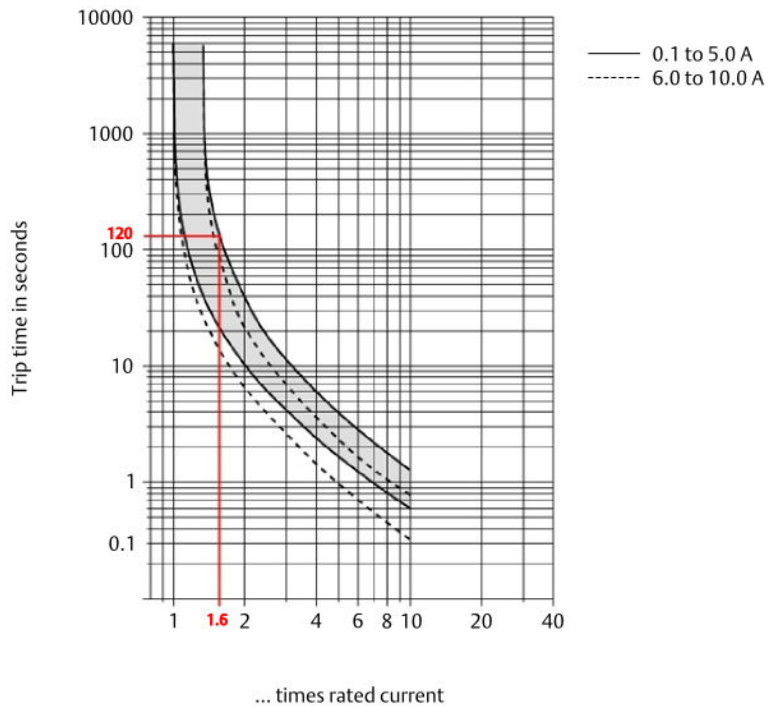

3. Calculate the required rated current by dividing the maximum allowed current by the multiple of the rated current.

$$I_{\text{rated}} = I_{\text{max}} / \text{multiple} = 8.33 \text{ A} / 1.6 = 5.2 \text{ A}$$

This example shows that all 1180-01 (E-T-A) circuit breakers with a rated current up to 5.0 A can be considered as feasible pre-fuses for a supply voltage of 24 V.

Use this procedure for any other fuse families. If applicable, consider the fuse temperature derating factor. Another circuit breaker family with ON/OFF functionality is the TCP family of Phoenix Contact.

4.6.2 Connecting sensors to the System Rack

The connection depends on the installed protection card and measuring task. The following sensor types and process signals can be connected:

- Eddy current measuring chains (for example PR 6423 with CON 011) – [Connect eddy current measuring chains](#)
- Piezoelectric sensors (for example PR 9270 -Ex) – [Connect piezoelectric sensors](#)
- Seismic sensors (for example PR 9268/600-000) – [Connect electrodynamic \(seismic\) sensors](#)
- Low frequency bearing vibration sensors (for example LF-24) – [Connect low frequency bearing vibration sensor LF-24](#)

- Linear displacement transducers (for example PR 9350) – [Connect linear displacement transducers](#)
- Speed sensors (for example PR 9376, Hall-effect sensor) – [Connect Hall-effect sensors](#)
- Variable reluctance sensors (VR sensors) – [Connect VR sensors](#)
- Temperature sensors (for example RTDs and thermocouple sensors) – [Connect temperature sensors](#)
- Voltage and current process signals – [Connect process signals](#)

Connect eddy current measuring chains

Eddy current measuring chains can be used for the following measuring tasks:

- Shaft vibration
- Shaft position, shaft expansion, differential expansion
- Speed
- Generation of key pulses for example for analysis purposes

[Figure 4-25](#) shows the connection of eddy current measuring chains consisting of sensor of type PR 6422, PR 6423, PR 6424, PR 6425 and PR 6426 and converter of type CON 011, CON 021, CON 031 and CON 041.

Recommendations

- Twisted pair and double screened cables, such as LiYCY-CY.
- Use one twisted pair for converter supply and another pair for the sensor signal.

Connections

- Channel 1 sensor signal: Connect the converter terminal **Out** to **XRx1.1** and terminal **GND** to **XRx1.2**.
- Channel 1 converter supply: Connect the converter terminal **-24V** to **XRx1.4** and terminal **GND** to **XRx1.3**.
- Channel 2 sensor signal: Connect the converter terminal **Out** to **XRx2.1** and terminal **GND** to **XRx2.2**.
- Channel 2 converter supply: Connect the converter terminal **-24V** to **XRx2.4** and terminal **GND** to **XRx2.3**.

Further information regarding the eddy current measuring chains can be found in their respective operating manuals. For information regarding grounding and connection of cable screens, see [EMC-compliant installation and grounding example](#).

Figure 4-25: Connection example for eddy current measuring chains

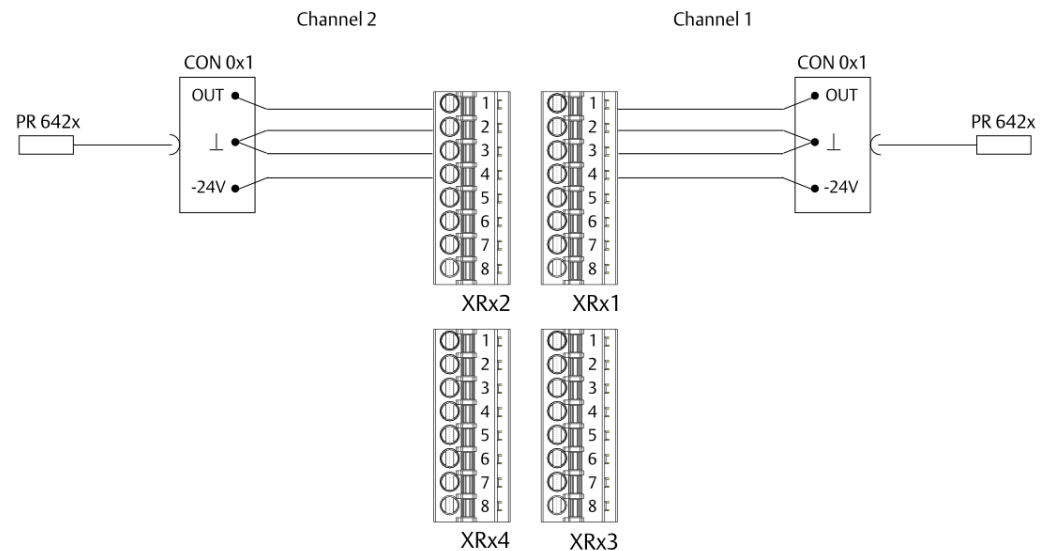

x = slot number 1 to 6 (A6500-FR), 1 to 9 (A6500-RR), or 1 to 11 (A6500-SR)

Connect 3-wire eddy current measuring chains

Use eddy current measuring chains for measuring tasks listed in [Connect eddy current measuring chains](#).

Figure 4-26 shows a 3-wire connection example of an eddy current measuring chain consisting of an AMS EZ 1000 Converter and an AMS EZ 1000 Sensor.

Recommendations

For the connection of an AMS EZ 1000 Converter, screened cables, for example, of type LiYCY 2x2x0.25 can be used.

Connections

- Channel 1 sensor signal: Connect the converter terminal **Out** to XRx1.1 and terminal **GND** to XRx1.2.
- Channel 1 converter supply: Connect the converter terminal **-24 V** to XRx1.4.
- Make a ground connection between XRx1.2 and XRx1.3.
- Channel 2 sensor signal: Connect the converter terminal **Out** to XRx2.1 and terminal **GND** to XRx2.2.
- Channel 2 converter supply: Connect the converter terminal **-24 V** to XRx2.4.
- Make a ground connection between XRx2.2 and XRx2.3.

Note

Because of the limited EMC robustness is the 3-wire connection of eddy current sensors not the preferred connection method.

For further information about the used eddy current measuring chains see the related operating manual. For information about grounding and connection of cable shields see [EMC-compliant installation and grounding example](#).

Figure 4-26: 3-wire connection example of an eddy current sensors

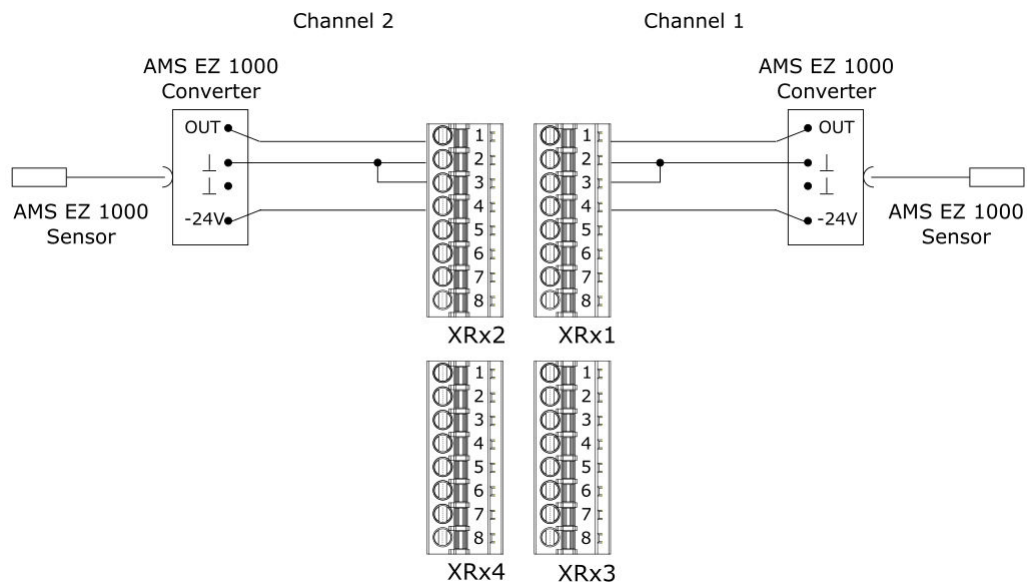

Connect piezoelectric sensors

Piezoelectric sensors like PR 9270-Ex (acceleration) or PR 9270V-Ex (velocity) are generally used to measure bearing vibration.

[Figure 4-27](#) shows the connection of piezoelectric sensors of type PR 9270-Ex.

Recommendations

- Twisted pair and double screened cables, such as LiYCY-CY.

Connections

- Channel 1: Connect the sensor terminal **A** to **XR1.1** and terminal **B** to **XR1.2**.
- Channel 2: Connect the sensor terminal **A** to **XR2.1** and terminal **B** to **XR2.2**.

Further information regarding piezoelectric sensors can be found in their respective operating manuals. For information regarding grounding and connection of cable screens, see [EMC-compliant installation and grounding example](#).

Figure 4-27: Connection example for piezoelectric sensors

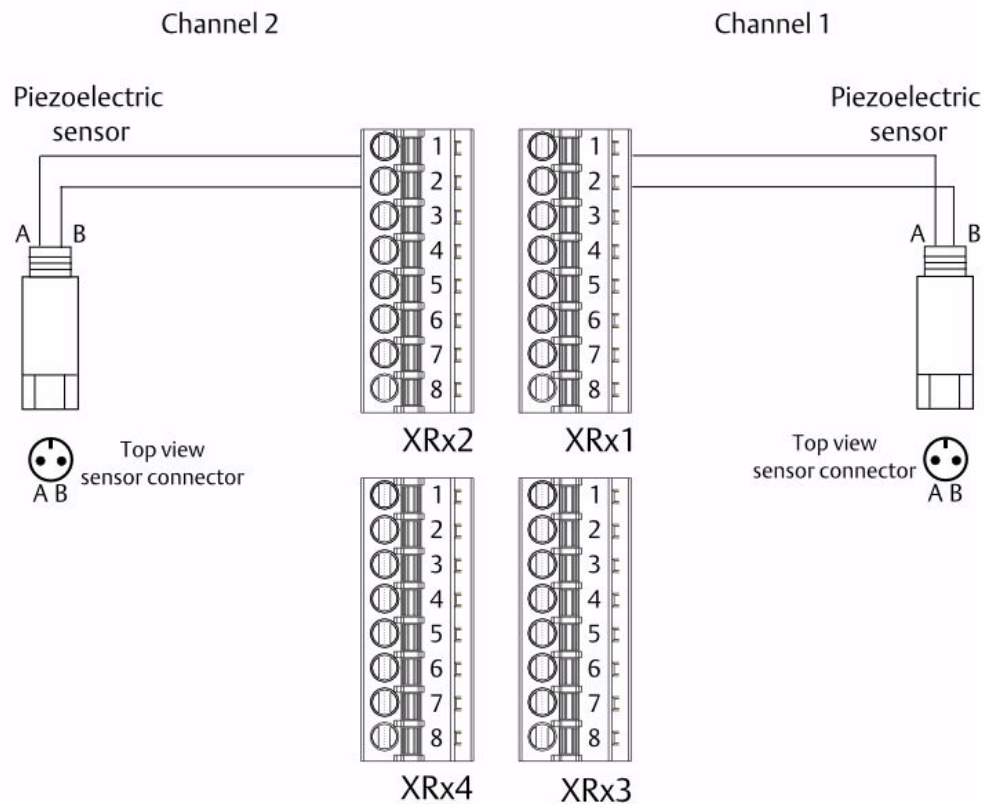

x = slot number 1 to 6 (A6500-FR), 1 to 9 (A6500-RR), or 1 to 11 (A6500-SR)

Connect 3-wire piezoelectric sensors

Piezoelectric sensors are generally used to measure bearing vibration.

Figure 4-28 shows the connection of -24 V DC powered 3-wire piezoelectric sensors such as GE 330400 and GE 330425.

Recommendations

- Twisted pair and double screened cables, such as LiYCY-CY.

Connections

- Channel 1 sensor signal: Connect the sensor terminal **A** to **XR1.1** and terminal **C** to **XR1.2**.
- Channel 1 sensor supply: Connect the sensor terminal **B** to **XR1.4** and terminal **C** to **XR1.3**.
- Channel 2 sensor signal: Connect the sensor terminal **A** to **XR2.1** and terminal **C** to **XR2.2**.
- Channel 2 sensor supply: Connect the sensor terminal **B** to **XR2.4** and terminal **C** to **XR2.3**.

Further information regarding 3-wire piezoelectric sensors can be found in their respective operating manuals. For information regarding grounding and connection of cable screens, see [EMC-compliant installation and grounding example](#).

Figure 4-28: Connection example for 3-wire piezoelectric sensors

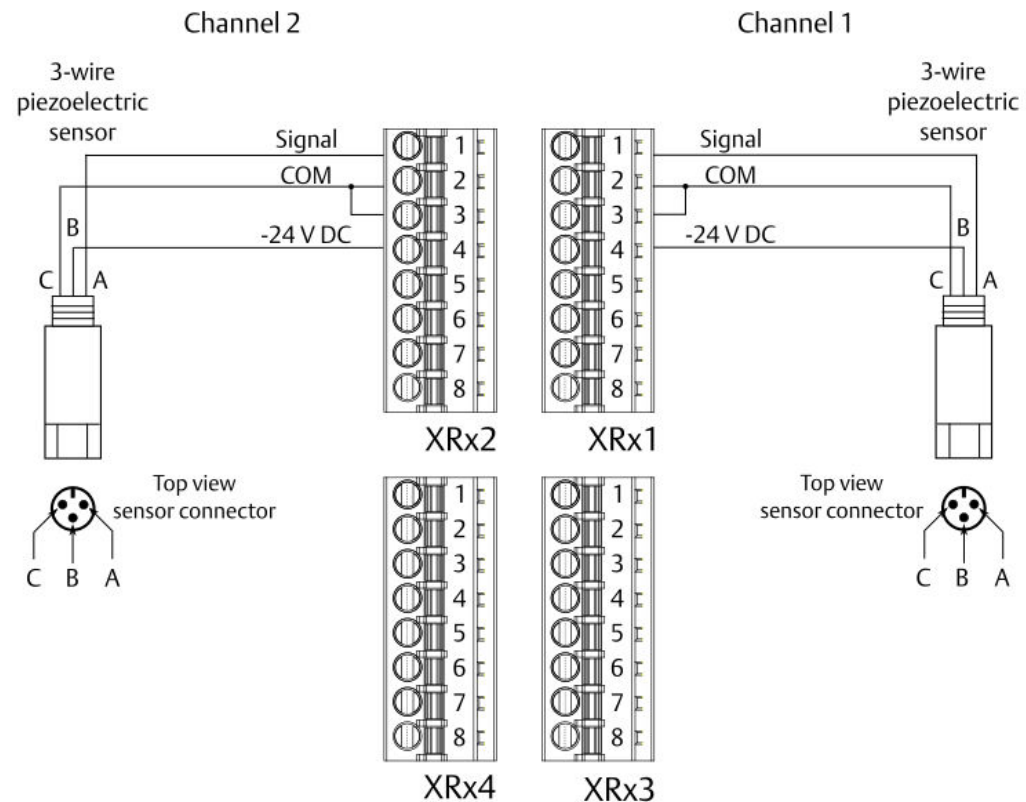

x = slot number 1 to 6 (A6500-FR), 1 to 9 (A6500-RR), or 1 to 11 (A6500-SR)

Connect dynamic pressure sensor chains

Dynamic pressure is often measured with sensor chains consisting of a piezoelectric sensor, a charge amplifier, and a galvanic isolator.

See [Figure 4-29](#) for an example for connection of a sensor chain for measuring dynamic pressure. The measuring chain is externally supplied.

Recommendations

- Twisted pair and double screened cables, such as LiYCY-CY.

Connections

- Channel 1: Connect the **Signal Output** terminal of the galvanic isolator to **XR1.1** and the **GND/0V** terminal to **XR1.2**.
- Channel 2: Connect the **Signal Output** terminal of the galvanic isolator to **XR2.1** and the **GND/0V** terminal to **XR2.2**.

For further information on dynamic pressure sensors, see their respective operating manuals. For information about grounding and connection of cable shields, see [EMC-compliant installation and grounding example](#). For connection of 2-wire dynamic pressure sensors with integrated charge amplifier, see [Connect piezoelectric sensors](#).

Figure 4-29: Connection example for dynamic pressure sensor chains

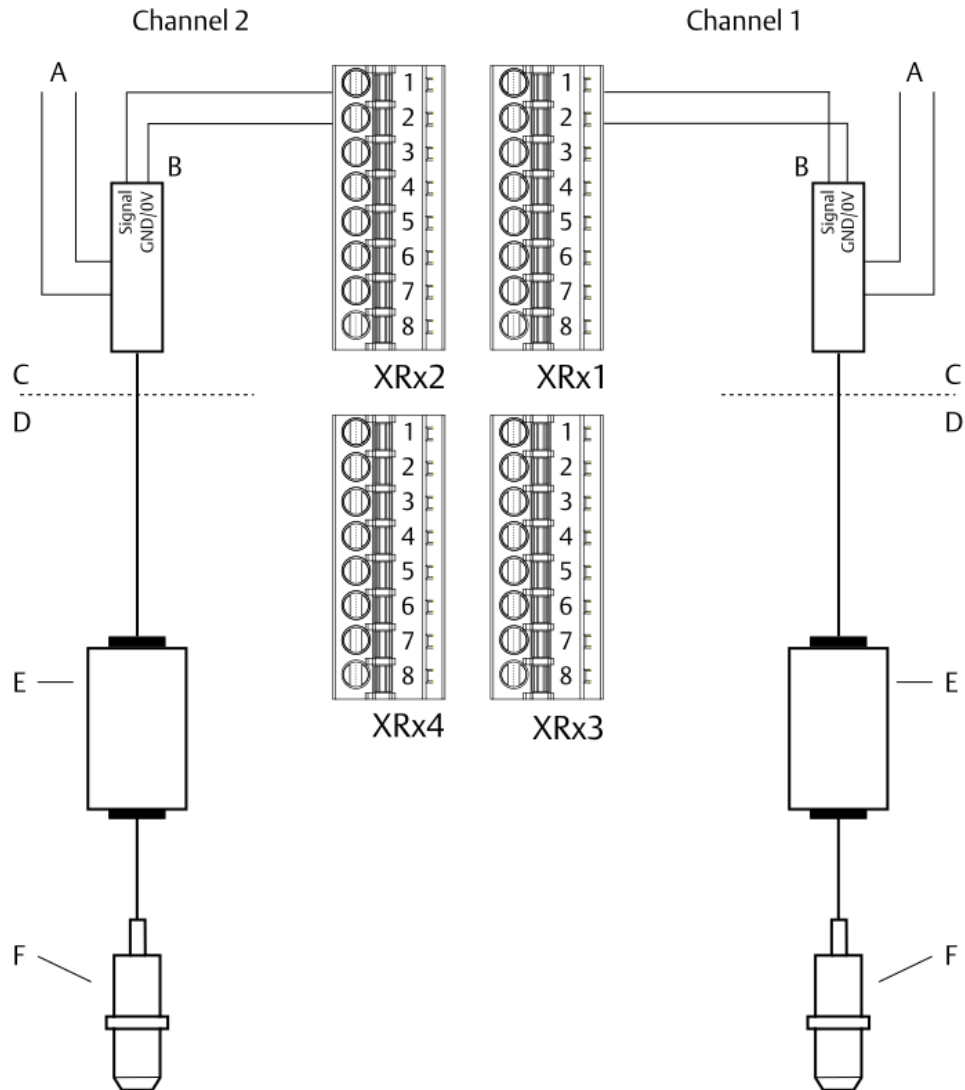

- A. External voltage supply to supply the sensor chain.
- B. Galvanic isolator
- C. Cabinet
- D. Field
- E. Charge amplifier
- F. Dynamic pressure sensor

Connect static pressure sensors – Bently Nevada 165855

Static pressure sensors are used to measure different kinds of quantities such as suction pressure, discharge pressure, or peak rod compression at reciprocating compressors.

See [Figure 4-30](#) for an example for connection of a static pressure sensor.

Connections

- Channel 1 sensor signal: Connect the **Signal output** terminal of the static pressure sensor to **XRx1.1** and the **Signal return/Common** terminal to **XRx1.2**.
- Channel 1 sensor supply: Connect the **Power supply +** terminal of the static pressure sensor to **XRx1.3** and connect **XRx1.4** to **XRx1.2**.
- Channel 2 sensor signal: Connect the **Signal output** terminal of the static pressure sensor to **XRx2.1** and the **Signal return/Common** terminal to **XRx2.2**.
- Channel 2 sensor supply: Connect the **Power supply +** terminal of the static pressure sensor to **XRx2.3** and connect **XRx2.4** to **XRx2.2**.

For further information on static pressure sensors, see their respective operating manuals. For information about grounding and connection of cable shields, see [EMC-compliant installation and grounding example](#).

Figure 4-30: Connection example for static pressure sensors – Bently Nevada 165855

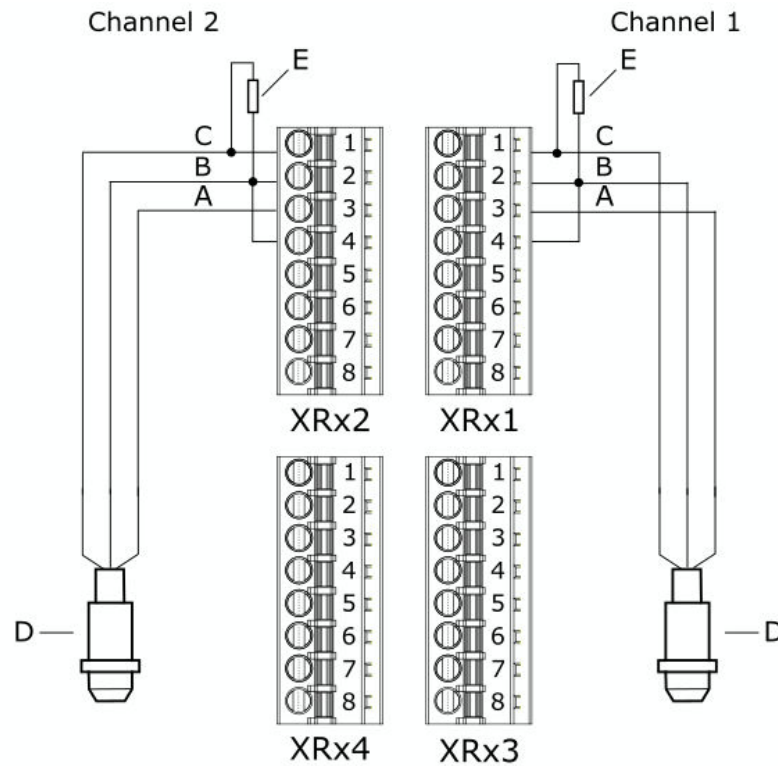

- A. Power supply +
- B. Common
- C. Signal
- D. Static pressure sensor
- E. Additional 20 kΩ resistor for channel OK detection if using Bently Nevada 165855 sensors

x = slot number 1 to 6 (A6500-FR), 1 to 9 (A6500-RR), or 1 to 11 (A6500-SR)

Open circuit detection

Add a 20 kΩ resistor to the sensor signal input to detect an open signal circuit if using Bently Nevada 165855 sensors. Place this resistor as close as possible to the sensor input terminals (see Figure 4-30).

Channel 1 Connect the resistor parallel to the signal input between XR1.1 and XR1.2.

Channel 2 Connect the resistor parallel to the signal input between XR2.1 and XR2.2.

x = slot number 1 to 6 (A6500-FR), 1 to 9 (A6500-RR), or 1 to 11 (A6500-SR)

Connect electrodynamic (seismic) sensors

Electrodynamic sensors are generally used to measure bearing vibration.

Figure 4-31 shows the connection of electrodynamic sensors of type PR 9268/20x-xxx and PR 9268/30x-xxx.

Recommendations

- Twisted pair and double screened cables, such as LiYCY-CY.

Connections

- Channel 1: Connect the sensor terminal 3 to **XRx1.2** and terminal 2 to **XRx1.1** (only if sinking is required, otherwise connect the sensor as shown for channel 2).
- Channel 2: Connect the sensor terminal 3 to **XRx2.1** and terminal 2 to **XRx2.2**.

Further information regarding seismic sensors can be found in their respective operating manuals. For information regarding grounding and connection of cable screens, see [EMC-compliant installation and grounding example](#).

Figure 4-31: Connection example for electrodynamic sensors

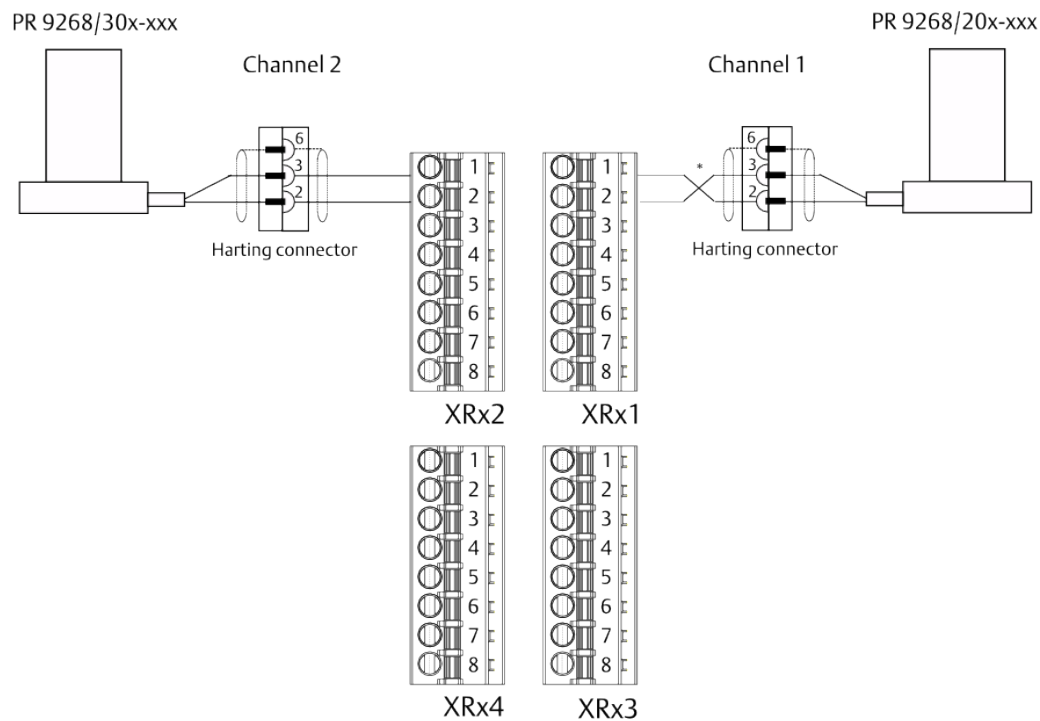

x = slot number 1 to 6 (A6500-FR), 1 to 9 (A6500-RR), or 1 to 11 (A6500-SR)

* To feed a sinking current for sensors in vertical measuring direction (PR 9268/20x-xxx or PR 9268/60x-xxx), swap the signal wires on terminal 2 and 3 of the Harting connector, as shown. See the sensor manual for details on sinking and lifting current.

Connect low frequency bearing vibration sensor LF-24

The sensor LF-24 is designed to measure low frequency bearing vibration.

[Figure 4-32](#) shows the connection of the LF-24.

Recommendations

- Twisted pair and double screened cables such as LiYCY-CY.

Connections

- Channel 1 sensor signal: Connect the sensor terminal 1 (Signal +) to **XRx1.1** and terminal 2 (Signal GND) to **XRx1.2**.
- Channel 1 sensor supply: Connect the sensor terminal 4 (Power +) to **XRx1.3**, terminal 5 (Power -) to **XRx1.4**, and terminal 3 (Power GND) to **XRx1.5**.
- Channel 2 sensor signal: Connect the sensor terminal 1 (Signal +) to **XRx2.1** and terminal 2 (Signal GND) to **XRx2.2**.
- Channel 2 sensor supply: Connect the sensor terminal 4 (Power +) to **XRx2.3**, terminal 5 (Power -) to **XRx2.4**, and terminal 3 (Power GND) to **XRx2.5**.

Further information regarding the LF-24 can be found in its operating manual. For information regarding grounding and connection of cable screens, see [EMC-compliant installation and grounding example](#).

Figure 4-32: Connection example for the low frequency sensor LF-24

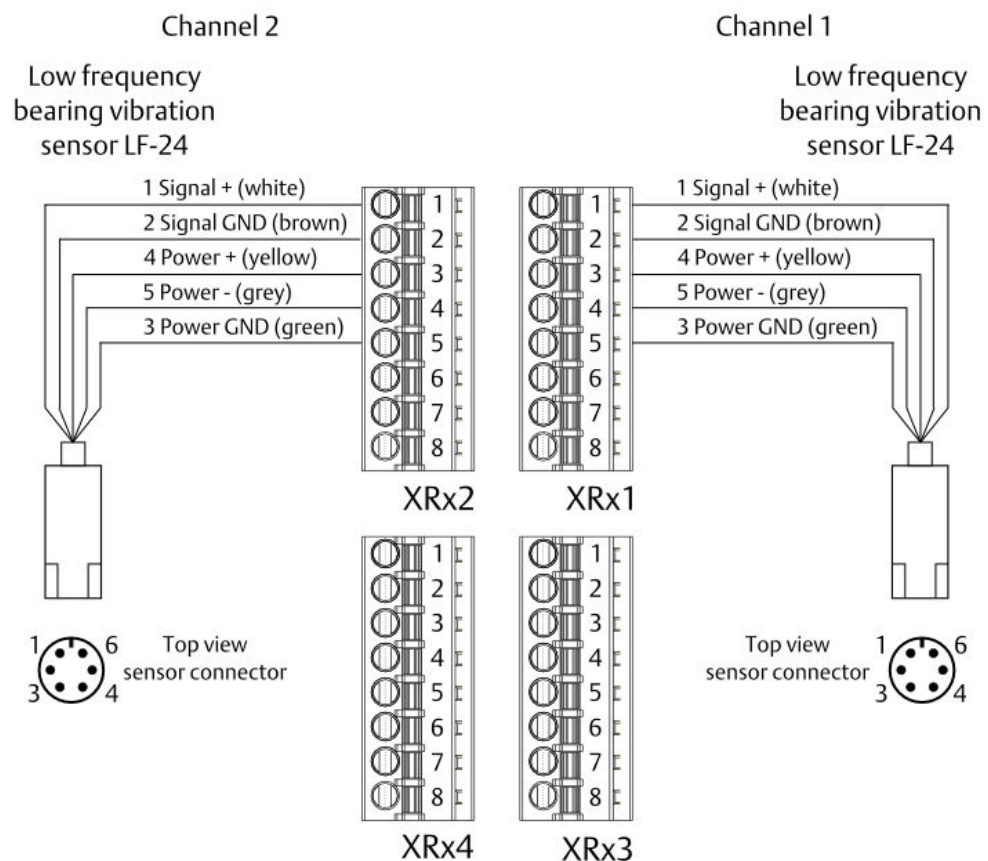

x = slot number 1 to 6 (A6500-FR), 1 to 9 (A6500-RR), or 1 to 11 (A6500-SR)

Connect linear displacement transducers

The A6500-LC converter is necessary for connecting linear displacement transducers. [Figure 4-33](#) shows the connection of an A6500-LC to the System Rack.

Recommendations

- Twisted pair and double screened cables, such as LiYCY-CY.
- Use one twisted pair for converter supply and another pair for the sensor signal.

Connections

- Channel 1 sensor signal: Connect the converter terminal 3 to **XR_x1.1** and terminal 4 to **XR_x1.2**.
- Channel 1 converter supply: Connect the converter terminal 1 to **XR_x1.3** and terminal 2 to **XR_x1.4**.
- Channel 2 sensor signal: Connect the converter terminal 3 to **XR_x2.1** and terminal 4 to **XR_x2.2**.
- Channel 2 converter supply: Connect the converter terminal 1 to **XR_x2.3** and terminal 2 to **XR_x2.4**.

Further information can be found in the operating manual of the A6500-LC LVDT Converter. For information regarding grounding and connection of cable screens, see [EMC-compliant installation and grounding example](#).

Figure 4-33: Connection example for A6500-LC LVDT Converter

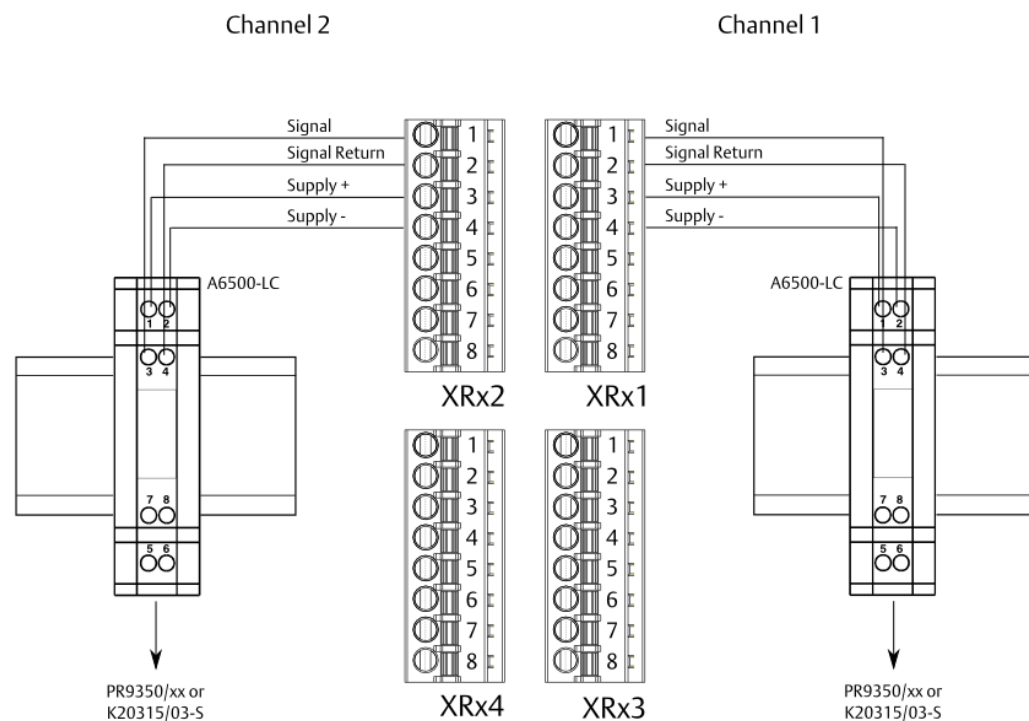

x = slot number 1 to 6 (A6500-FR), 1 to 9 (A6500-RR), or 1 to 11 (A6500-SR)

Connect Hall-effect sensors

The PR 9376 Hall-effect sensor is used to measure speed or to generate key pulses (for example, for analytical purposes).

Figure 4-34 shows the connection of Hall-effect sensors of type PR 9376.

Recommendations

- Twisted pair and double screened cables such as LiYCY-CY.

Connections

- Channel 1: Connect the **white sensor wire** to **XR_x1.1**, the **blue wire** to **XR_x1.3**, and the **sensor cable shield** to **XR_x1.2** and **XR_x1.4**.
- Channel 2: Connect the **white sensor wire** to **XR_x2.1**, the **blue wire** to **XR_x2.3**, and the **sensor cable shield** to **XR_x2.2** and **XR_x2.4**.

Further information regarding hall-effect sensors can be found in their respective operating manuals. For information regarding grounding and connection of cable screens, see [EMC-compliant installation and grounding example](#).

Figure 4-34: Connection example for Hall-effect sensors

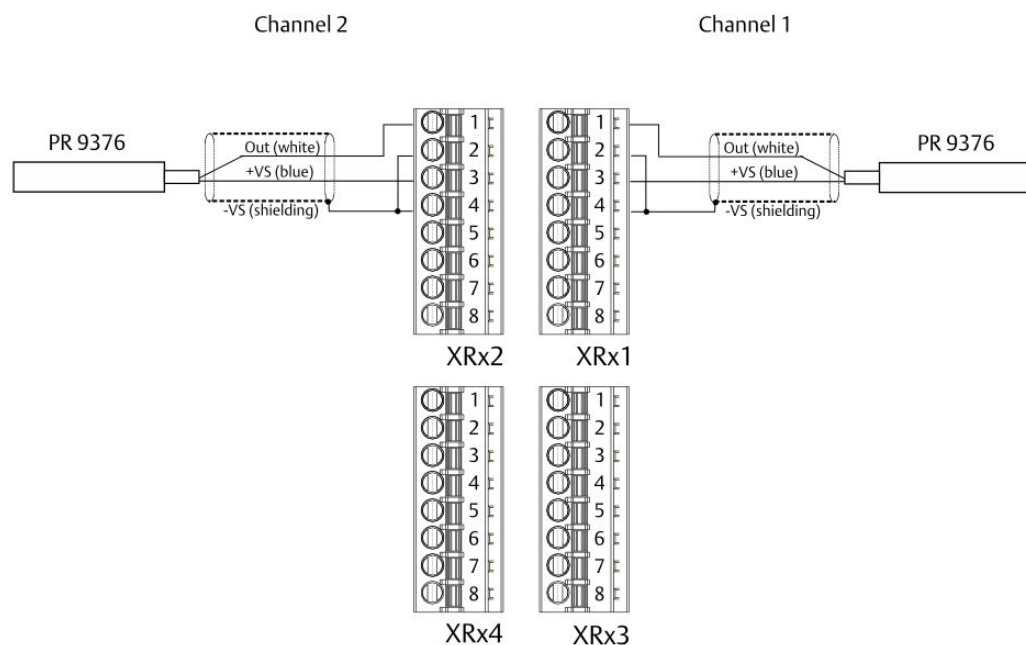

x = slot number 1 to 6 (A6500-FR), 1 to 9 (A6500-RR), or 1 to 11 (A6500-SR)

Connect VR sensors

Variable reluctance sensors (VR sensors), also known as MPUs (magnetic pickups), are used to measure machine speed or to generate key pulses for analytical purposes.

⚠ DANGER

The output voltage level of VR sensors depends on the mounting position and the speed of the measuring object and can reach voltages higher than the permissible input voltage range of 30 V of the A6500-UM card. Ensure that the voltage at the signal input does not exceed 30 V. Emerson recommends the use of a Zener barrier to limit the output voltage of the connected VR sensor to avoid damaging the card.

See [Figure 4-35](#) for a connection example.

Recommendations

- Twisted pair and double screened cables such as LiYCY-CY

Connections

- Channel 1: Connect the **Signal output** terminal of the barrier to **XRx1.1** and the **GND/0V** terminal to **XRx1.2**
- Channel 2: Connect the **Signal output** of the barrier to **XRx2.1** and the GND/0V terminal to **XRx2.2**.

Further information about VR sensors can be found in their respective operating manuals. For information about grounding and connection of cable screens, see [EMC-compliant installation and grounding example](#).

Figure 4-35: Connection example for VR sensors

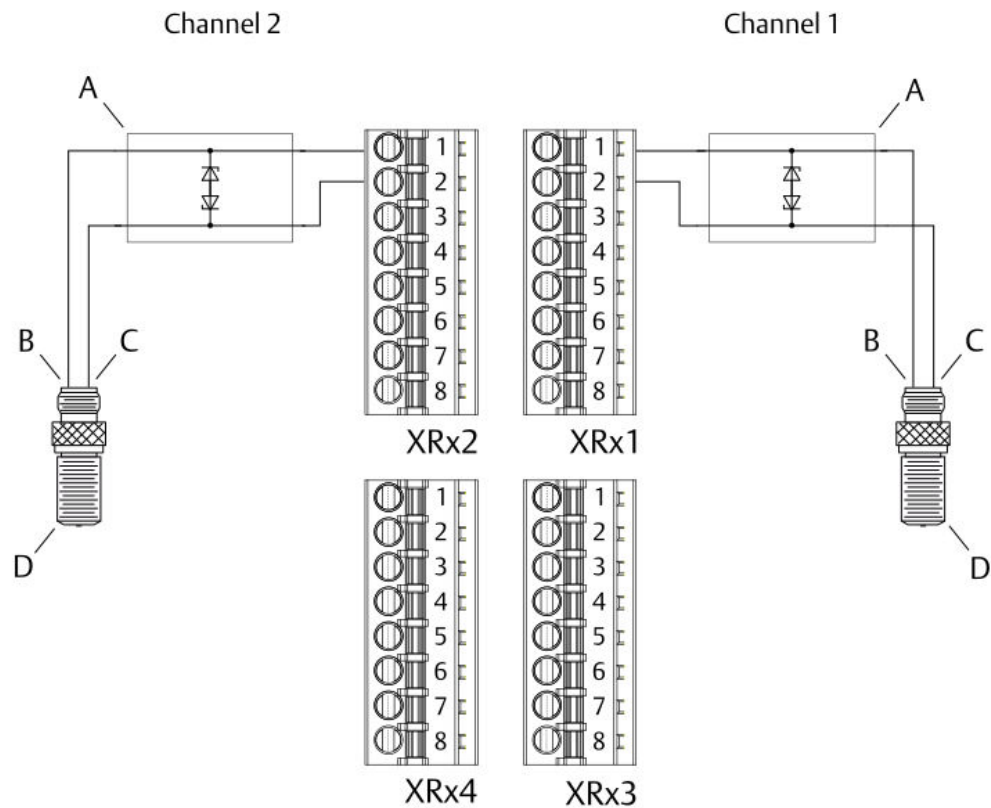

- A. Barrier for signal voltage limitation.
- B. Pin A of the sensor connector
- C. Pin B of the sensor connector
- D. VR sensor

Connect temperature sensors

⚠ CAUTION

Ensure that the thermocouples are always connected with the correct polarity. The thicker line of the thermocouple symbol always indicates the minus connection. The thin line marks the plus connection (see Figure 4-36).

Figure 4-36: General thermocouple connection symbol

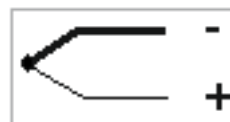

Thermocouple types and the polarities of thermocouple wires are identified with colors. The different coloring of thermocouple sheaths and wires are subject to various national standards. Figure 4-37 to Figure 4-41 show the colors of thermocouple sheaths, wires and their polarity that comply with the European standard IEC 584-3. Standards of other countries may differ.

Figure 4-37: Thermocouple - Type E

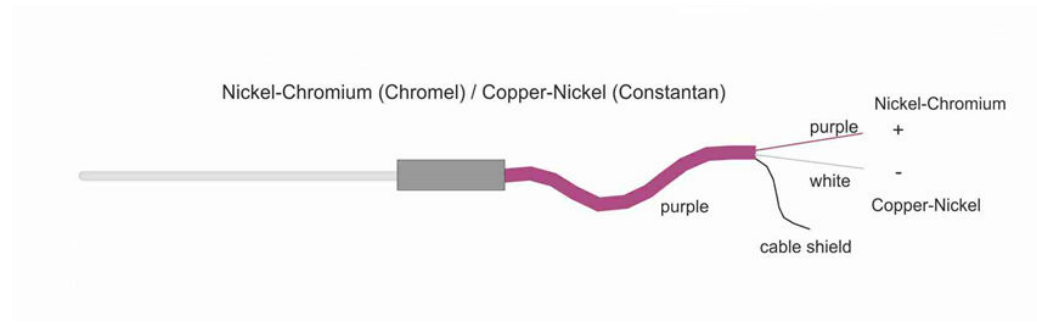

Figure 4-38: Thermocouple - Type J

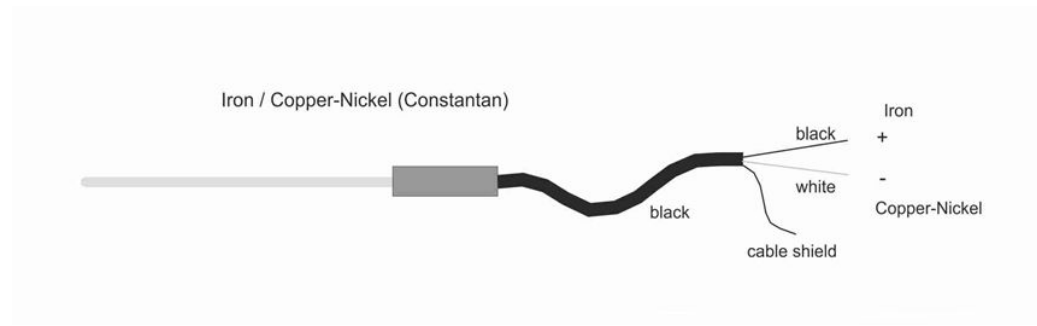

Figure 4-39: Thermocouple - Type K

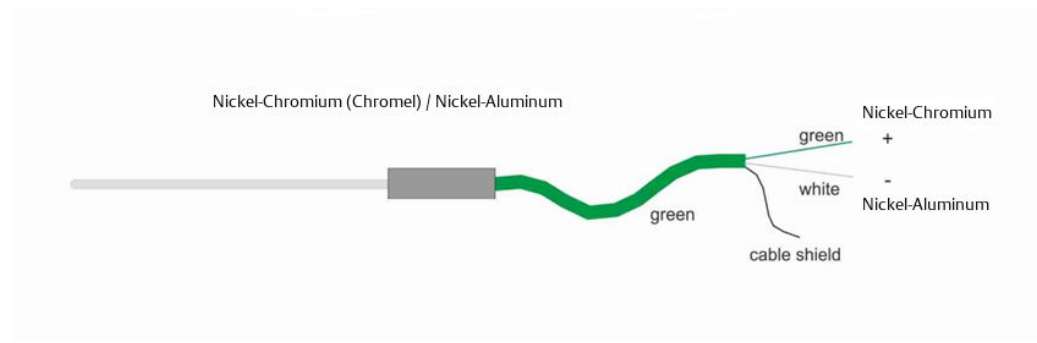

Figure 4-40: Thermocouple - Type N

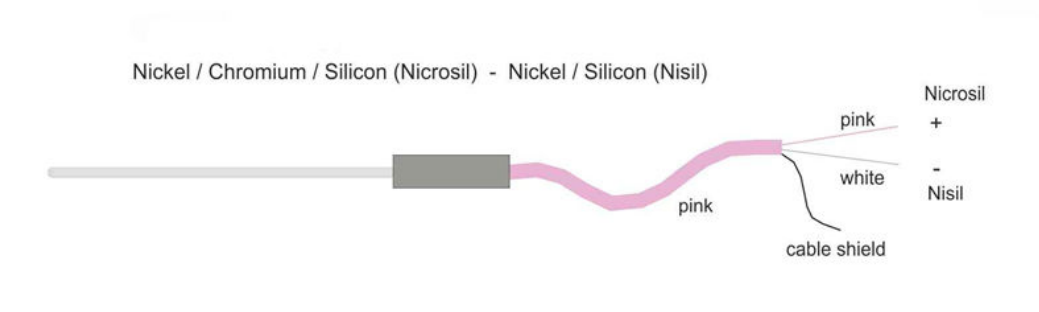
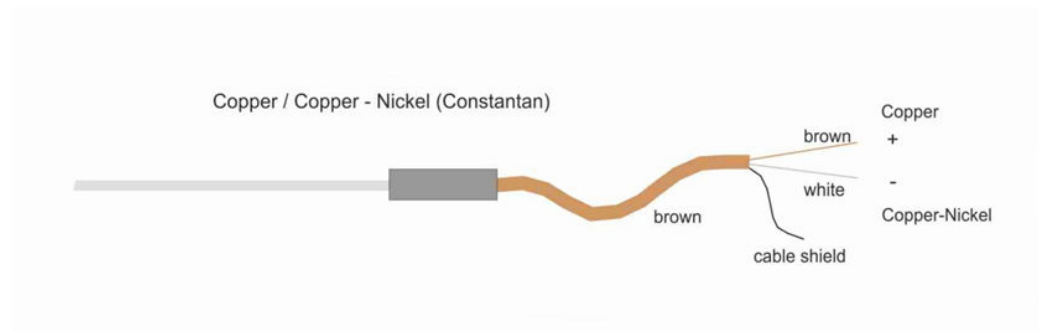

Figure 4-41: Thermocouple - Type T



To avoid errors in temperature measurements due to incorrectly connected thermocouples, observe the information provided by thermocouple supplier.

Shielding of thermocouple cables

Thermocouple cables consist of two thermocouple conductors, insulation material, cable shield and a metal protection sheath around the conductors. At one end, the two conductors and the sheath are welded and constitute the hot junction point. At insulated versions of thermocouples, the conductors of the thermopair are welded without electric contact to the sheath.

CAUTION

When connecting thermocouples to the A6500-TP Temperature Process Cards, ensure that insulated thermocouple versions are used. Uninsulated thermocouple versions may result in unstable or disturbed measurements because the electric potential (ground / earth) from the measuring points is lead via the thermocouple into the measuring circuits by disabling the electric isolation. See [Figure 4-42](#) and [Figure 4-43](#).

Figure 4-42: Design of insulated thermocouple versions

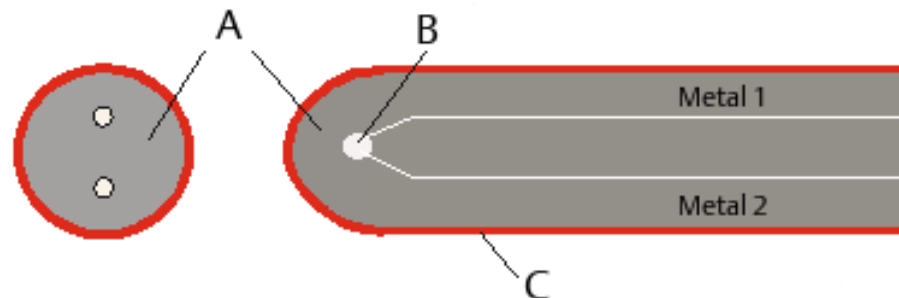

- A. Insulated material
- B. Welding point (hot junction point)
- C. Thermocouple sheath interconnected with cable screen

Figure 4-43: Design of uninsulated thermocouple versions

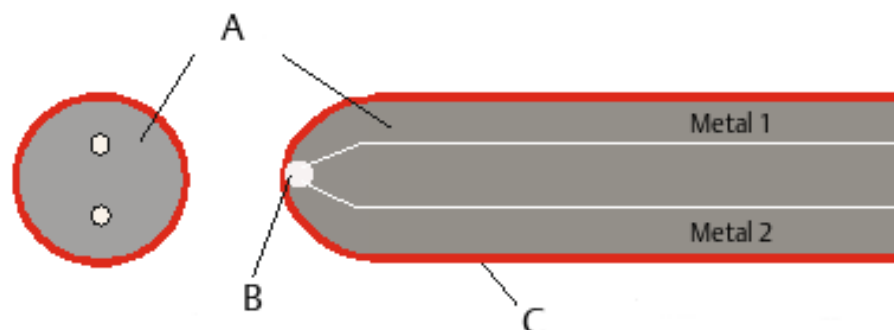

- A. Insulated material
- B. Welding point (hot junction point)
- C. Thermocouple sheath interconnected with cable screen

Connection of RTDs

Resistance temperature detectors (RTDs) are non-polarized components that change their resistance as the temperature changes. The A6500-TP Temperature Process Cards are designed for the connection of the following types:

Table 4-6: A6500-TP connection types

Type	Temperature sensor	Basic resistance	Temperature range	Sensor connection
Pt 100	Platin	100 Ω / 0°C	-200... +850°C	2-wire, 3-wire, 4-wire RTDs
Ni 100	Nickel	100 Ω / 0°C	-60... +180°C	
Ni 120	Nickel	120 Ω / 0°C	-80... +260°C	
Cu 10	Copper	10 Ω / 25°C	-200... +260°C	4-wire RTD

Table 4-7 and Figure 4-44 show the connection of 2-wire RTDs, 3-wire RTDs, 4-wire RTDs, and Thermocouples (TC).

Note

Temperature measurements with thermocouple sensors need to be equipped with a cold junction compensation to ensure proper measurement values and to eliminate influences of environmental mounting conditions.

Table 4-7: Sensor connections

Sensor type	Backplane terminals			
	Channel 1	Channel 2	Channel 3	Channel 4
2-wire RTD (Sub channel B)	XRx1.3	XRx2.3	XRx3.3	XRx4.3
	XRx1.4	XRx2.4	XRx3.4	XRx4.4
3-wire RTD	XRx1.2	XRx2.2	XRx3.2	XRx4.2
	XRx1.3	XRx2.3	XRx3.3	XRx4.3
	XRx1.4	XRx2.4	XRx3.4	XRx4.4
4-wire RTD	XRx1.1	XRx2.1	XRx3.1	XRx4.1
	XRx1.2	XRx2.2	XRx3.2	XRx4.2
	XRx1.3	XRx2.3	XRx3.3	XRx4.3
	XRx1.4	XRx2.4	XRx3.4	XRx4.4
Thermocouple (Sub channel A)	XRx1.1 (-)	XRx2.1 (-)	XRx3.1 (-)	XRx4.1 (-)
	XRx1.2 (+)	XRx2.2 (+)	XRx3.2 (+)	XRx4.2 (+)
Thermocouple (Sub channel B)	XRx1.3 (-)	XRx2.3 (-)	XRx3.3 (-)	XRx4.3 (-)
	XRx1.4 (+)	XRx2.4 (+)	XRx3.4 (+)	XRx4.4 (+)

x = slot number 1 to 6 (A6500-FR), 1 to 9 (A6500-RR), or 1 to 11 (A6500-SR)

Figure 4-44: Sensor connection

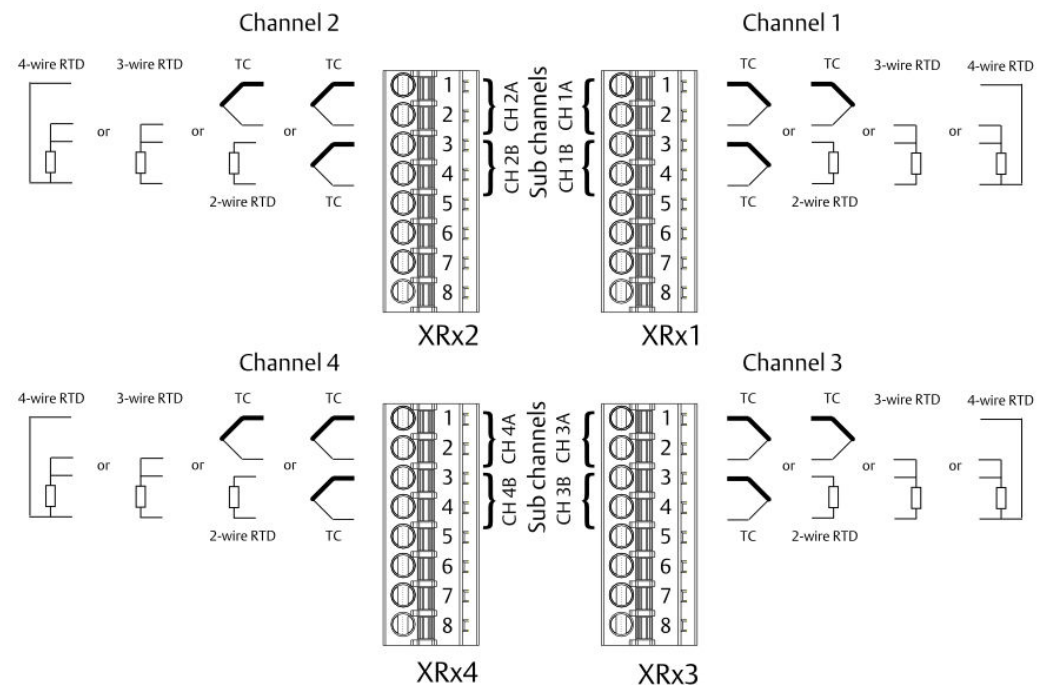

x = slot number 1 to 6 (A6500-FR), 1 to 9 (A6500-RR), or 1 to 11 (A6500-SR)

You can mix temperature input signals and process input signals channel-by-channel. For example, you can connect a voltage signal to channel 1 and a 3-wire RTD to channel 2 of the Temperature Process Card.

Connect process signals

Table 4-8 and Figure 4-45 shows the connection of process signals. Process signals within the following ranges can be connected:

- 0 to 1 V
- 0 to 10 V
- 0 to 20 mA
- 4 to 20 mA

Recommendations

- Twisted pair and double screened cables, such as LiYCY-CY.

Connections

Table 4-8: Signal connections

Signal	Channel 1	Channel 2	Channel 3	Channel 4
U (Voltage)	XR1.1	XR2.1	XR3.1	XR4.1
	XR1.3	XR2.3	XR3.3	XR4.3

Table 4-8: Signal connections (continued)

Signal	Channel 1	Channel 2	Channel 3	Channel 4
I (Current)	XR _x 1.1	XR _x 2.1	XR _x 3.1	XR _x 4.1
	XR _x 1.3	XR _x 2.3	XR _x 3.3	XR _x 4.3

x = slot number 1 to 6 (A6500-FR), 1 to 9 (A6500-RR), or 1 to 11 (A6500-SR)

Figure 4-45: Connection of process signals

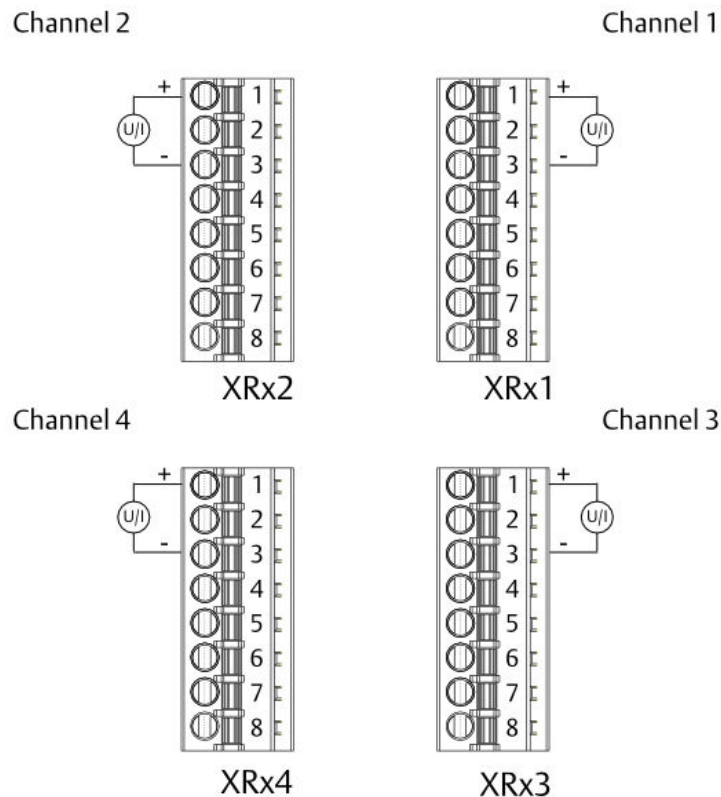

x = slot number 1 to 6 (A6500-FR), 1 to 9 (A6500-RR), or 1 to 11 (A6500-SR)

You can mix temperature input signals and process input signals channel-by-channel. For example, you can connect a voltage signal to channel 1 and a 3-wire RTD to channel 2 of the Temperature Process Card.

4.7 Slide switch settings — digital inputs and key-signals

The System Racks allow you to connect up to five digital inputs to the Universal Measurement Card and up to two digital inputs to the Temp / Process Card.

Key-signals are generated by an Universal Measurement Card in key mode and can be provided to other Universal Measurement Cards.

The slide switches for each slot configure the digital inputs and key-signals. Slide switches 1 to 5 configure the digital inputs, and slide switch 6 supplies the key-signal function. For location of the slide switches, see [Figure 3-2](#) (A6500-SR), [Figure 3-5](#) (A6500-RR), or [Figure 3-7](#) (A6500-FR).

4.7.1 Digital inputs

You can connect five digital inputs to a card slot. If an Universal Measurement Card is installed, use all five digital inputs. If a Temperature Process Card is installed, use the first two digital inputs.

The backplane of the System Racks interconnects the five digital inputs of slots 1 to 6 (A6500-FR), 1 to 9 (A6500-RR), or 1 to 11 (A6500-SR). Digital input signals can be fed at each slot. The connection terminals for the digital inputs are:

Digital input	Terminal
DIN 1	XR _x 1.8 ¹
DIN 2	XR _x 2.8 ¹
DIN 3	XR _x 2.7 ¹
DIN 4	XR _x 3.1 ¹
DIN 5	XR _x 3.2 ¹

¹ x = slot number 1 to 6 (A6500-FR), 1 to 9 (A6500-RR), or 1 to 11 (A6500-SR)

You can use a digital input signal connected to one of the card slots at all other slots. You can select the digital signals at the other slots with the slide switches S_x.1 to S_x.5. [Figure 4-46](#) shows the connection structure of the digital inputs. The figure shows that you can directly connect digital input signals with the 8-pole terminals, or that you can switch already available digital input signals with the slide switches to the slot.

Figure 4-46: Digital input general wiring diagram

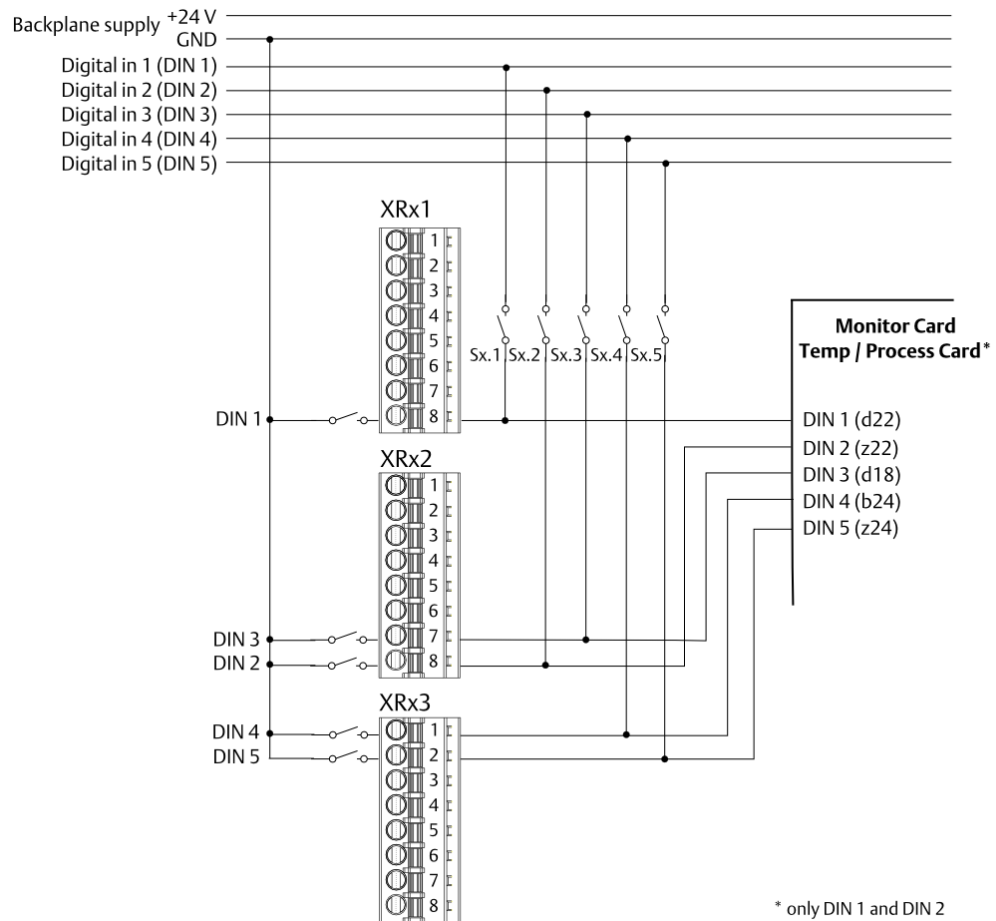

The function of the digital inputs depends on the configuration of the card installed in the appropriate slot. You can use these digital inputs for functions such as resetting of latched alarms, limit level multiplier, and bypass. The digital inputs work according to the "Low - active" principle. If the selected function is active, the input is switched to ground (GND). The function is inactive if the input is open or switched to +24 V DC.

Wiring and configuration example for function reset latch

Figure 4-47 shows a wiring and configuration example for digital input 1 used as reset latch for a card in slot 1 and slot 2. In this example, digital input 1 (DIN 1) of slot 1 is connected to GND. The digital input becomes active if the switch between GND and terminal XR11.8 is closed. The digital signal is connected through the backplane to the second card by the closed slide switches S1.1 and S2.1.

Figure 4-47: Digital input example diagram

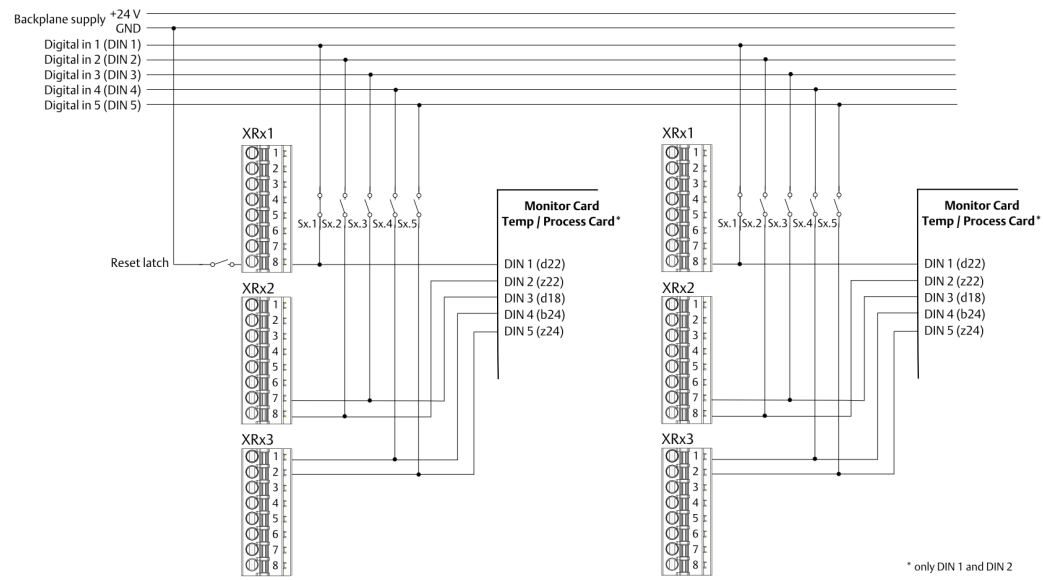

4.7.2

Key-signal

This section describes the System Rack configuration for providing key-signals. Each Universal Measurement Card can work as a two-channel key card. Universal Measurement Cards in key mode can be installed in slots 1 to 6 (A6500-FR), 1 to 9 (A6500-RR), or 1 to 11 (A6500-SR). The following steps describe the configuration of an arbitrary slot for providing a key-signal.

Prerequisites

Determine the slot you want to configure to provide a key-signal.

Determine if you want to use digital input 1 and/or digital input 2 for your key-signal.

Procedure

1. Close slide switch Sx.6 to supply both key-signals with 24 V.
2. Install a wire jumper between XR1.6 and XR1.8 to connect the key-signal to digital input 1.
3. Close slide switch Sx.1 to connect key-signal 1 to the digital input 1 track of the backplane.
4. If you are using the second channel of the Universal Measurement Card in key mode:
 - a) Install a wire jumper from XR2.6 to XR2.8 to connect the key-signal to digital input 2.
 - b) Close slide switch Sx.2 to connect key-signal 2 to the digital input 2 of the backplane.

Prerequisites

Note

Only digital input 1 and digital input 2 can be used for forwarding key-signals to other slots.

The following items describe the configuration of an arbitrary slot for key-signal input.

- If using key-signal 1, close slide switch Sx.1.
- If using key-signal 2, close slide switch Sx.2.

Figure 4-48 shows the slot configuration for Universal Measurement Card in key mode and how a key-signal is supplied to other Universal Measurement Cards.

Figure 4-48: Key-signal configuration

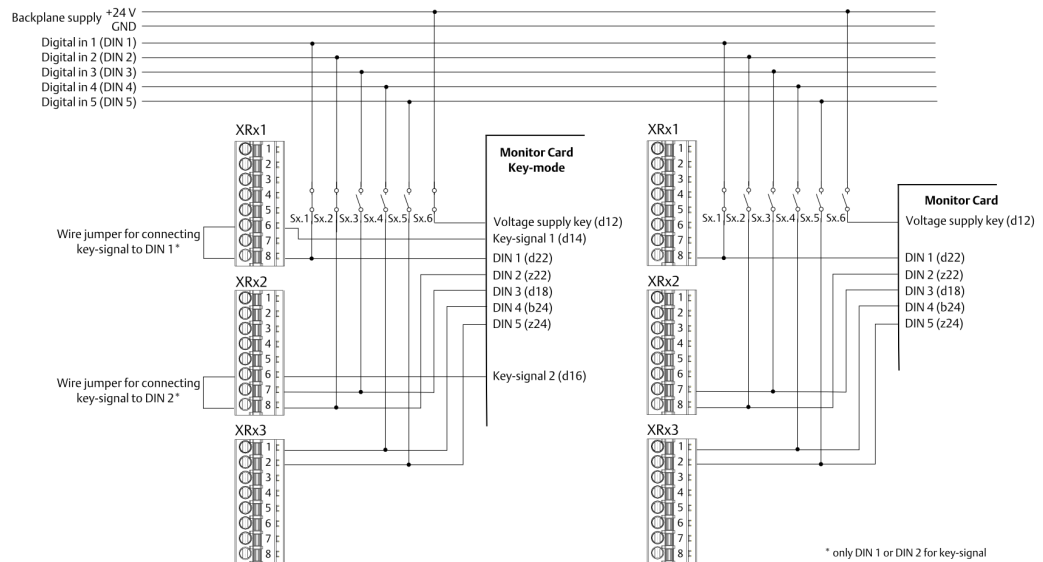

x = number of slots 1 to 6 (A6500-FR), 1 to 9 (A6500-RR), or 1 to 11 (A6500-SR)

Note

Key-signal 1 and key-signal 2 are also available on the 9-pole D-Sub connector CD25 (A6500-RR) or CD26 (A6500-SR) to connect to prediction systems.

Key-signal 1: pin 6; GND: pin 7

Key-signal 2: pin 8; GND: pin 9

Not for A6500-FR.

The 9-pole D-Sub connector is output only. Do not use this connector for feeding in signals.

Connect a key-signal to a second A6500-xR System Rack

The key-signal, generated by an A6500-UM card in key mode, can be connected to further A6500-UM cards installed in a second A6500-xR System Rack. Up to 21 A6500-UM card channels can be connected to one channel of an A6500-UM card in key mode.

Figure 4-49 explains the connection of a key-signal to a second rack. In this example, slot 1 of the first A6500-SR System Rack is configured to generate a key-signal (Key 1) with channel 1 of an installed A6500-UM card:

- Wire jumper between XR11.6 and XR11.8
- Slide switches S1.1 and S1.6 are closed (ON)

The slide switch Sx.1 of the slots 2 to 11 (of the first System Rack) is closed to distribute the key-signal to all installed A6500-UM cards. The key-signal is connected with a wire bridge between terminal XR11.8 of the first System Rack and terminal XR11.8 of the second System Rack to slot 1 of the second System Rack from where the key-signal is distributed to the slots 2 to 11.

Figure 4-49: Example for a connection of a key-signal to a second rack

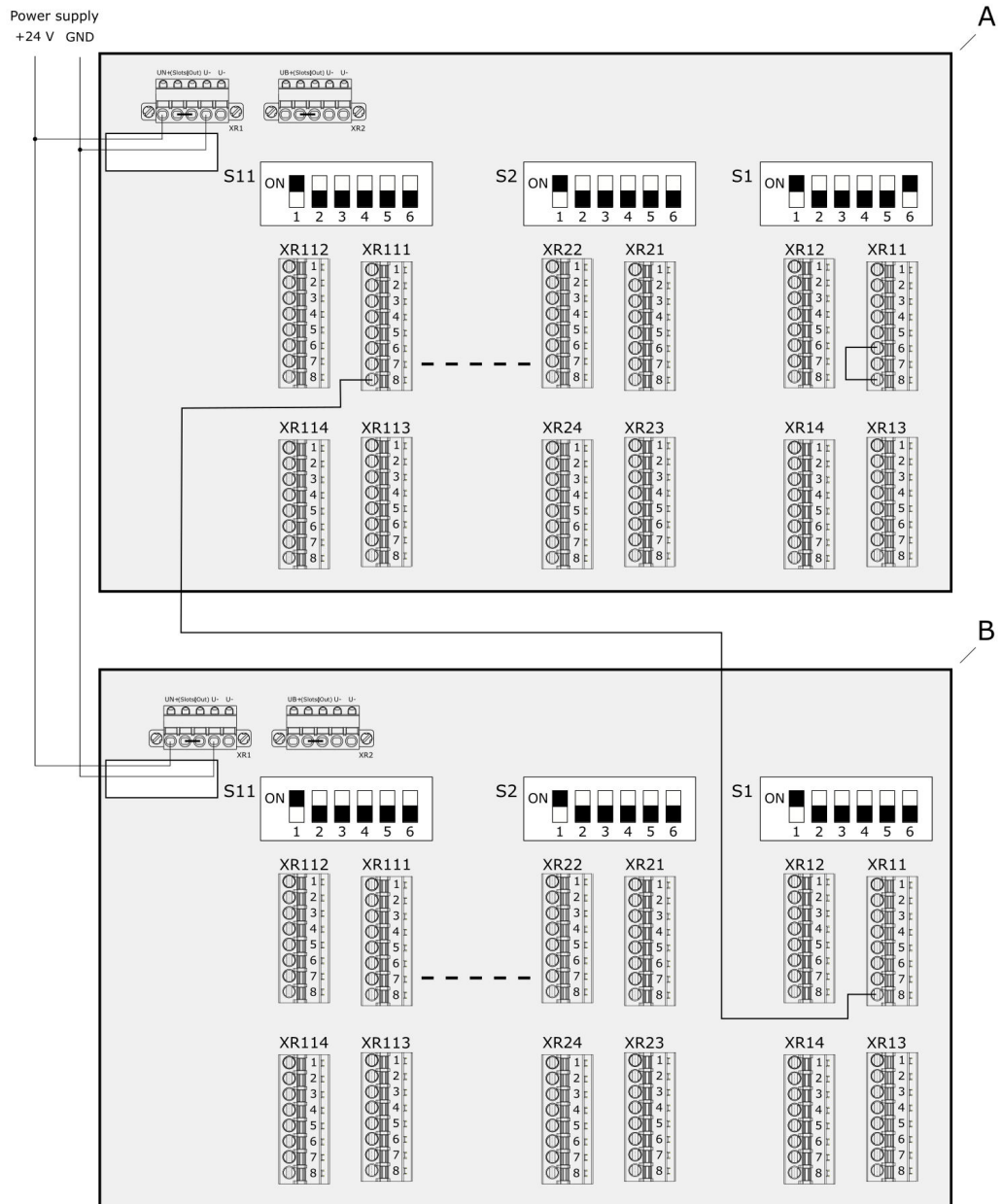

- A. First A6500-SR System Rack
- B. Second A6500-SR System Rack

Prerequisites

- Short wire jumper for connecting the key-signal to the digital input, wire cross section in accordance to [Table 4-3](#) (6- and 8-pole screw terminal connectors) or [Table 4-4](#) (6- and 8-pole spring cage connectors).

- Wire with a suitable length for connecting the key-signal to the second rack, same wire cross section as used for the wire jumper.
- Flat head screwdriver for the screw terminal connectors.
- Ensure that both A6500-xR System Racks are connected to the same ground (GND). Emerson recommends to use the same power supply connection option (see [Power supply](#)) for both System Racks.
- Determine the slot you want to configure to provide a key-signal.
- Determine which digital input you want to use for the key-signal, digital input 1, digital input 2, or both of them if both channels of the A6500-UM card are used for generating key-signals.

Procedure

1. Prepare the slot of the A6500-UM card used for the generation of the key-signal as described in [Key-signal](#).
2. Close the appropriate slide switch of each slot of the first System Rack where an A6500-UM card is installed that requires a key-signal. Close slide switch 1 (ON) if key-signal 1 is used or close slide switch 2 (ON) if key-signal 2 is used. Both key-signals can be also connected to one A6500-UM card.
3. Connect the key-signal with a wire bridge to the second System Rack.

Key-signal (Key 1) Install a wire bridge between terminal XR111.8 of the first System Rack and terminal XR11.8 of the second System Rack.

Key-signal (Key 2) Install a wire bridge between terminal XR112.8 of the first System Rack and terminal XR12.8 of the second System Rack.

4. Close the appropriate slide switch of each slot of the second System Rack where an A6500-UM card is installed that requires a key-signal. Close slide switch 1 (ON) if key-signal 1 is used or close slide switch 2 (ON) if key-signal 2 is used.

4.8 Communication

The system can be operated with one or two Com Cards (A6500-FR: one Com Card). At least one Com Card is required to configure Universal Measurement Cards, Temperature Process Cards, and the Relay Card. If redundant Modbus communication is required, install a second Com Card.

Note

The bus communication structure requires no further configuration. All necessary bus terminations and references exist on the backplane and cards.

The Com Card is equipped with a RJ45 socket for configuration, OPC UA, and Modbus over TCP/IP communication. The backplane has a recess for the RJ45 socket of the Com Card(s).

The 6-pole screw terminal connector connects the serial Modbus communication (Modbus RTU) to the Com Card. The pin assignment of this connector is shown in [Figure 4-50](#) for A6500-SR and A6500-RR and in [Figure 4-51](#) for A6500-FR.

Figure 4-50: Pin assignment Modbus RTU communication – A6500-SR and A6500-RR

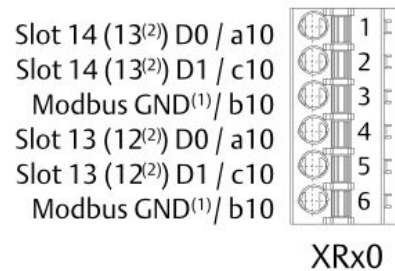

(1) Modbus GND is galvanically separated from the system GND.

(2) A6500-RR

x = 12 (A6500-RR) or 13 (A6500-SR)

Figure 4-51: Pin assignment Modbus RTU communication – A6500-FR

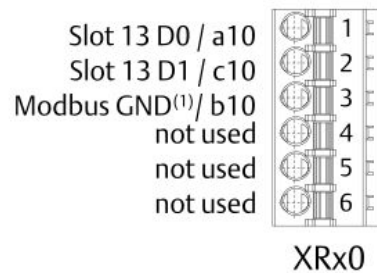

(1) Modbus GND is galvanically separated from the system GND.

x = 13

4.8.1 Bus line interconnection of two System Racks

The bus lines of two System Racks can be interconnected. This setup consists of two System Racks (A6500-RR or A6500-SR) and one or two Com Cards installed in the first System Rack. Com Cards are not required for the second System Rack.

The A6500-FR System Rack does not support the bus line interconnection of two racks.

Procedure

1. Install one Com Card into the left communication card slot (A6500-RR: slot CD12, A6500-SR: slot CD13).
Install an additional Com Card in the remaining communication slot if you require redundant communication.

Note

Emerson recommends using the left slot (A6500-RR: slot CD12, A6500-SR: slot CD13) for single Com Card installations and for the primary Com Card in redundant

systems, and the right slot (A6500-RR: slot CD13, A6500-SR: slot CD14) for the secondary Com Card in redundant systems.

2. Use the 9-pole male and female D-Sub 1 m cable to connect the bus lines.
 - a) Connect the female connector of the cable to the 9-pole D-Sub socket OUT (CD32) of the first System Rack with the installed Com Card(s).
 - b) Connect the male connector of the cable to the 9-pole D-Sub socket IN (CD31) of the second System Rack.

Available accessory for interconnection of the bus lines of two racks:

 - MHM-6XXX-RC-Cable - Rack connection cable, SUB-D connector, 9-pole, 1 meter
3. Secure the 9-pole connectors by gently fastening the screws.

The bus lines of the second System Rack are now connected to the first System Rack. The bus lines of both System Racks are now assigned to the Com Card(s).

4.8.2 A6500-FR – Ethernet connection

The A6500-CC Com Card must be connected to the rear of the A6500-FR with the included Ethernet cable for system operation. This connection is forwarded through to the front of the A6500-FR for access to the Com Card RJ45 after installation.

⚠ CAUTION

To keep the specifications of the A6500-FR, always use the cable supplied with the system rack.

[Figure 4-52](#) shows the rear of the A6500-FR with installed A6500-CC Com Card and the connected Ethernet cable.

Figure 4-52: Rear view A6500-FR with Ethernet cable

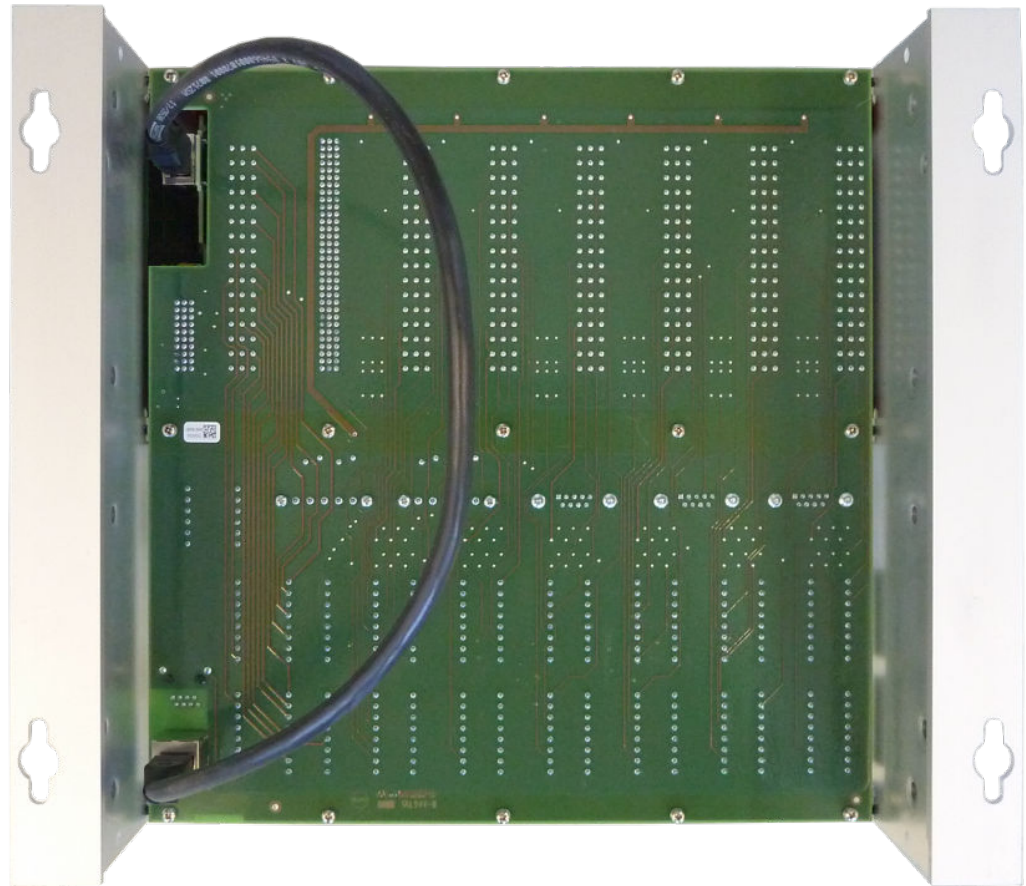

4.9 Sensor raw signal

The backplane of the System Racks is equipped with 9-pole D-Sub connectors that connect the sensor raw signals of each A6500-UM Universal Measurement Card installed to a prediction system. [Figure 4-53](#) shows the female 9-pole D-Sub connector. Maximum cable length for these outputs is 4 meters. The 9-pole connector CD25 (A6500-RR) or CD26 (A6500-SR) also provides two key-signals if they are switched to the digital input 1 track or the digital input 2 track of the System Rack.

Note

The A6500-TP Temperature Process Card does not provide sensor raw signals. If a Temperature Process Card has been installed, both sensor raw signal terminals of the slot are connected to GND.

Figure 4-53: Female 9-pole D-Sub connector

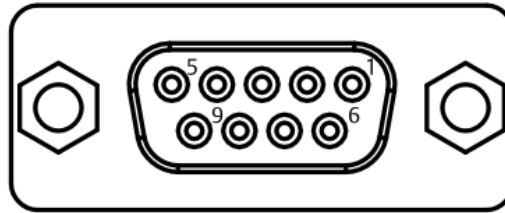

Table 4-9 lists the pin assignment of the 9-pole connectors.

⚠ CAUTION

Ensure that the shielding of the used connection cables is not connected to the System Rack and the prediction system. Connect cable shields only to the prediction system.

Table 4-9: Pin assignment sensor raw signal connectors

9-pole connector	Slot	Signal	Pin
CD21	1	Sensor raw signal 1	2
		GND	3
		Sensor raw signal 2	4
		GND	5
	2	Sensor raw signal 1	6
		GND	7
		Sensor raw signal 2	8
		GND	9
CD22	3	Sensor raw signal 1	2
		GND	3
		Sensor raw signal 2	4
		GND	5
	4	Sensor raw signal 1	6
		GND	7
		Sensor raw signal 2	8
		GND	9
CD23	5	Sensor raw signal 1	2
		GND	3
		Sensor raw signal 2	4
		GND	5
	6	Sensor raw signal 1	6

Table 4-9: Pin assignment sensor raw signal connectors (continued)

9-pole connector	Slot	Signal	Pin
		GND	7
		Sensor raw signal 2	8
		GND	9
CD24 ¹	7	Sensor raw signal 1	2
		GND	3
		Sensor raw signal 2	4
		GND	5
	8	Sensor raw signal 1	6
		GND	7
		Sensor raw signal 2	8
		GND	9
CD25 ¹	9	Sensor raw signal 1	2
		GND	3
		Sensor raw signal 2	4
		GND	5
	10 ³	Sensor raw signal 1	6
		GND	7
		Sensor raw signal 2	8
		GND	9
	Key-signal ²	DIN1 (Digital input 1)	6
		GND	7
		DIN2 (Digital input 2)	8
		GND	9
CD26 ³	11	Sensor raw signal 1	2
		GND	3
		Sensor raw signal 2	4
		GND	5
	Key-signal	DIN1 (Digital input 1)	6
		GND	7
		DIN2 (Digital input 2)	8
		GND	9

1 Not A6500-FR
2 Only A6500-RR
3 Only A6500-SR

Use these outputs for connecting sensor raw signals to prediction systems. The wiring example in [Figure 4-54](#) shows the connection of the sensor raw signals of the first two slots to four inputs of the AMS 6500 prediction system.

Figure 4-54: Sensor raw signal - connection example

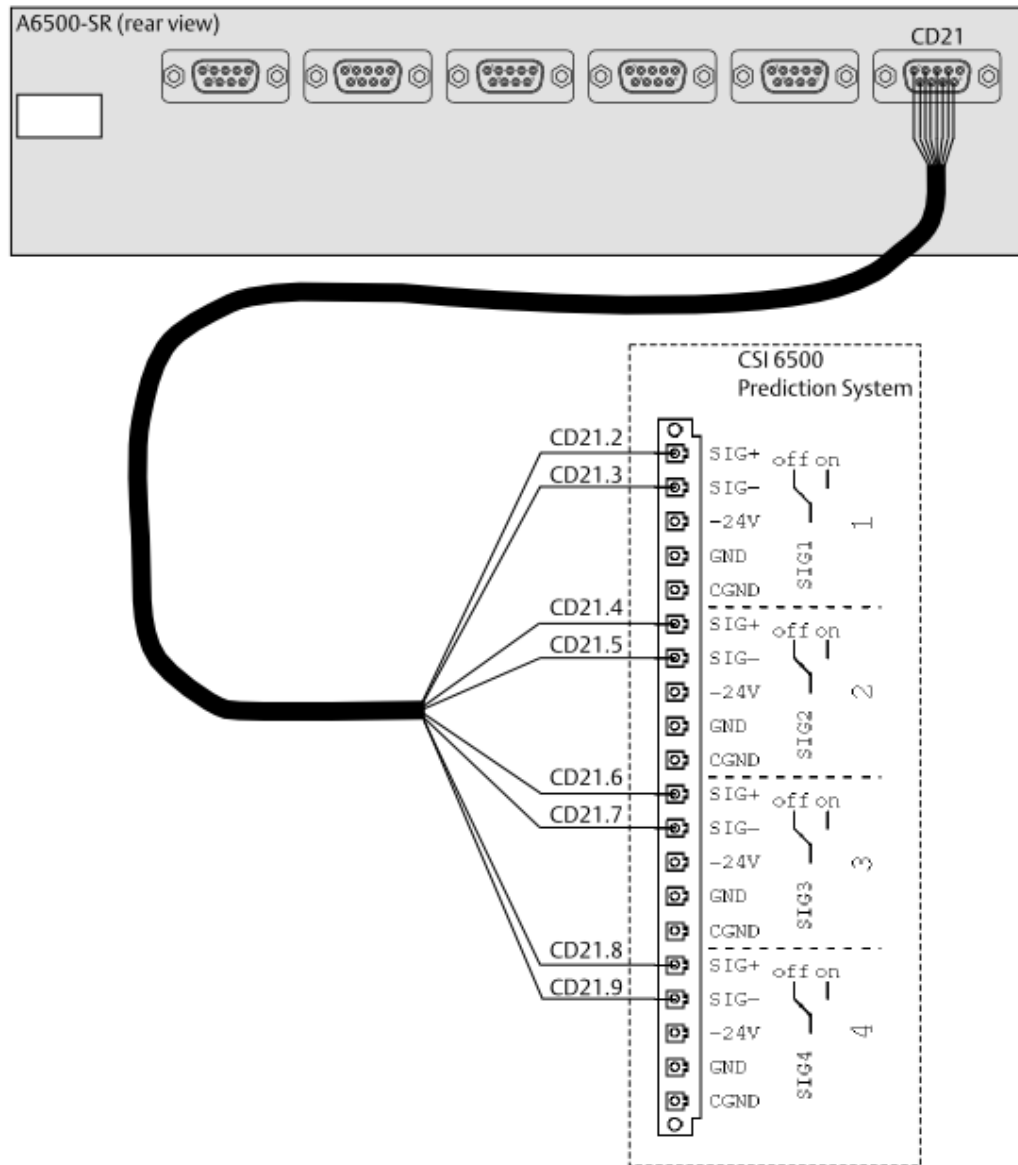

- CD21.2: Sensor raw signal slot 1, channel 1
- CD21.3: GND slot 1, channel 1
- CD21.4: Sensor raw signal slot 1, channel 2
- CD21.5: GND slot 1, channel 2
- CD21.6: Sensor raw signal slot 2, channel 1
- CD21.7: GND slot 2, channel 1
- CD21.8: Sensor raw signal slot 2, channel 2
- CD21.9: GND slot 2, channel 2

Available accessory for raw signal connection to a prediction system:

- Connection cable to 6500 Prediction: D25676 (9-pole male to blunt cut wire)

4.10 Connection of current outputs

Table 4-10 lists the terminal assignment of the two current outputs of the Universal Measurement Card and the four current outputs of the Temperature Process Card. Further information regarding the current outputs can be found in the respective operating manuals.

Table 4-10: Connection terminals current outputs

Current output	Terminal spring cage connectors	
	Universal Measurement Card	Temperature Process Card
1	XR _x 4.1 (Iout1+)	XR _x 1.6 (Iout1)
	XR _x 4.2 (Iout1-)	
2	XR _x 4.3 (Iout2+)	XR _x 1.7 (Iout2)
	XR _x 4.4 (Iout2-)	
3	---	XR _x 2.6 (Iout3)
4	---	XR _x 2.7 (Iout4)
Reference current output (GND)	---	XR _x 1.5 (for example, each GND of the slot can be used)

x = slot number 1 to 6 (A6500-FR), 1 to 9 (A6500-RR), or 1 to 11 (A6500-SR)

4.11 Digital outputs and Relay Card

The six digital outputs of the Universal Measurement Card and the Temperature Process Card are connected by the backplane of the System Rack to the inputs of the Relay Card. These digital outputs are also assigned to the 8-pole screw terminal connectors XR_x3 and XR_x4 of the slots 1 to 6 (A6500-FR), 1 to 9 (A6500-RR), or 1 to 11 (A6500-SR) for connection of standard relays. The digital outputs are nonreactive and internally supplied with 24 V by the voltage supply of the System Rack. Table 4-11 shows the assignment of the digital outputs of all slots to the 66 Relay Card inputs.

Table 4-11: Assignment of digital outputs to Relay Card inputs

Slot	Digital output	Input Relay Card	Slot	Digital output	Input Relay Card	Slot	Digital output	Input Relay Card
1	DOUT1	IN01	4	DOUT5	IN23	8 ²	DOUT3	IN45
	DOUT2	IN02		DOUT6	IN24		DOUT4	IN46
	DOUT3	IN03	5	DOUT1	IN25		DOUT5	IN47
	DOUT4	IN04		DOUT2	IN26		DOUT6	IN48
	DOUT5	IN05		DOUT3	IN27	9 ²	DOUT1	IN49

Table 4-11: Assignment of digital outputs to Relay Card inputs (continued)

Slot	Digital output	Input Relay Card	Slot	Digital output	Input Relay Card	Slot	Digital output	Input Relay Card
2	DOUT6	IN06	6	DOUT4	IN28	10 ¹	DOUT2	IN50
	DOUT1	IN07		DOUT5	IN29		DOUT3	IN51
	DOUT2	IN08		DOUT6	IN30		DOUT4	IN52
	DOUT3	IN09		DOUT1	IN31		DOUT5	IN53
	DOUT4	IN10		DOUT2	IN32		DOUT6	IN54
	DOUT5	IN11		DOUT3	IN33		DOUT1	IN55
3	DOUT6	IN12	7 ²	DOUT4	IN34	11 ¹	DOUT2	IN56
	DOUT1	IN13		DOUT5	IN35		DOUT3	IN57
	DOUT2	IN14		DOUT6	IN36		DOUT4	IN58
	DOUT3	IN15		DOUT1	IN37		DOUT5	IN59
	DOUT4	IN16		DOUT2	IN38		DOUT6	IN60
	DOUT5	IN17		DOUT3	IN39		DOUT1	IN61
4	DOUT6	IN18	8 ²	DOUT4	IN40		DOUT2	IN62
	DOUT1	IN19		DOUT5	IN41		DOUT3	IN63
	DOUT2	IN20		DOUT6	IN42		DOUT4	IN64
	DOUT3	IN21		DOUT1	IN43		DOUT5	IN65
	DOUT4	IN22		DOUT2	IN44		DOUT6	IN66

¹ Only A6500-SR
² Only A6500-SR and A6500-RR

The 66 digital signals connected to the System Rack can be processed within the Relay Card. The Relay Card is equipped with 16 relays with changeover contacts to output the results. At the A6500-SR and A6500-FR System Racks, the relay contacts are assigned to the 8-pole screw terminal connectors XR121 to XR126. At the A6500-RR System Rack, the relay contacts of the first Relay Card are assigned to the 8-pole screw terminal connectors XR101 to XR106 and of the second Relay Card to the connectors XR111 to XR116.

Figure 4-55 shows an example connection of external relays to the digital outputs. You can use relays of type PLC-RSC-24DC/21-21 (Phoenix) to connect to the digital outputs.

Figure 4-55: Digital outputs connection example

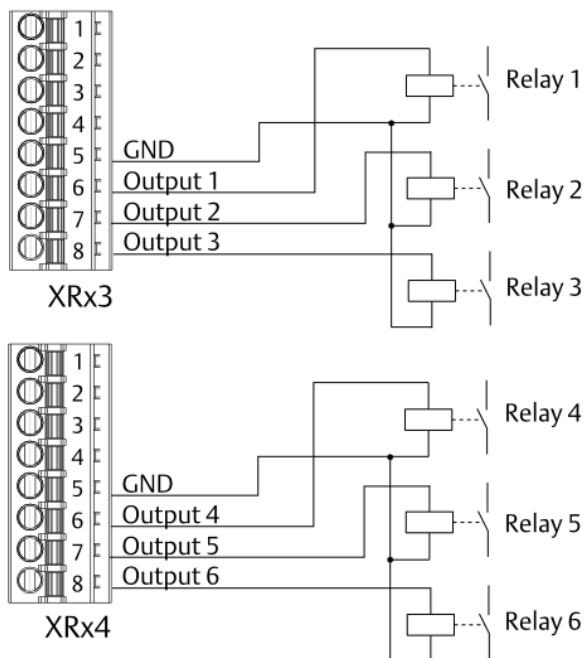

4.12 A6500-RR - external inputs

Because of the reduced number of protection card slots, 9 instead of 11, up to 12 external digital signals can be connected in parallel to both Relay Cards. Figure 4-56 shows the pin assignment of the 6-pole screw terminal connectors XR107 and XR108. See A6500-RC Relay Card operating manual (MHM-97876) for technical data of these digital inputs.

Figure 4-56: Pin assignment external Relay Card inputs

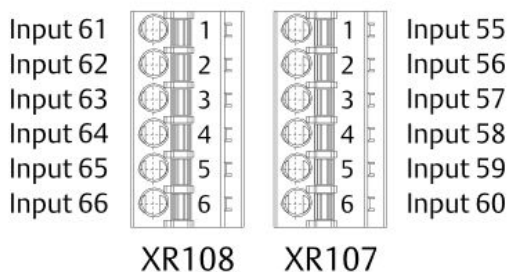

⚠ CAUTION

When connecting external signals to the Relay Cards, ensure that U- (GND) of the supply of the external signals is identical with U- (GND) of the digital output supply of the System Rack (see [Power supply](#)).

4.13 A6500-FR - external inputs

Up to six external digital signals can be connected to the Relay Card. [Figure 4-57](#) shows the pin assignment of the 6-pole screw terminal connector XR131. See A6500-RC Relay Card operating manual (MHM-97876) for technical data of these digital inputs.

Figure 4-57: Pin assignment external Relay Card inputs – A6500-FR

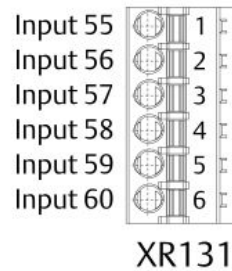

⚠ CAUTION

When connecting external signals to the Relay Card, ensure that U- (GND) of the supply of the external signals is identical with U-(GND) of the digital output supply of the System Rack (see [Power supply](#)).

4.14 Commission the System Rack

Procedure

1. Ensure that the System Rack has been correctly installed and meets the environmental requirements.
Cooling might be necessary due to the environmental temperature (see [Required installation space including cables and ventilation](#) and [Table 8-4](#)).
2. Ensure that all required cards are installed.
3. Ensure proper wiring.
4. Switch on the power supply.

5 Hazardous location installation

Version 1.10

5.1 General installation requirements

The A6500-SR, A6500-RR, and A6500-FR System Racks must be solely connected to SELV/PELV electrical circuits to meet the requirements for explosion protection. This also applies to all devices connected to the System Racks. The System Racks must be mounted into a suitable Ex e field housing for operation in hazardous areas Zone 2.

5.2 Field housing requirements

The field housing, including cable glands, must meet the following requirements:

- Protection class IP 54
- Allowed degree of pollution 2 or better as defined in IEC 60664-1
- Ex e approval according to EN 60079-0 and EN 60079-7
- Accessible only by using a tool

The following warning must be clearly legible on the outside:

WARNING - DO NOT OPEN IN HAZARDOUS ATMOSPHERE

ATTENTION - NE PAS OUVRIR DANS L'ATMOSPHÈRE DANGEREUSE

The terminal compartment must accommodate cable connections without any complications.

The [Figure 5-1](#) shows the recommended dimensions for the A6500-SR and A6500-RR System Racks and the [Figure 5-2](#) for the A6500-FR System Rack.

Figure 5-1: Dimension terminal compartment – A6500-SR and A6500-RR

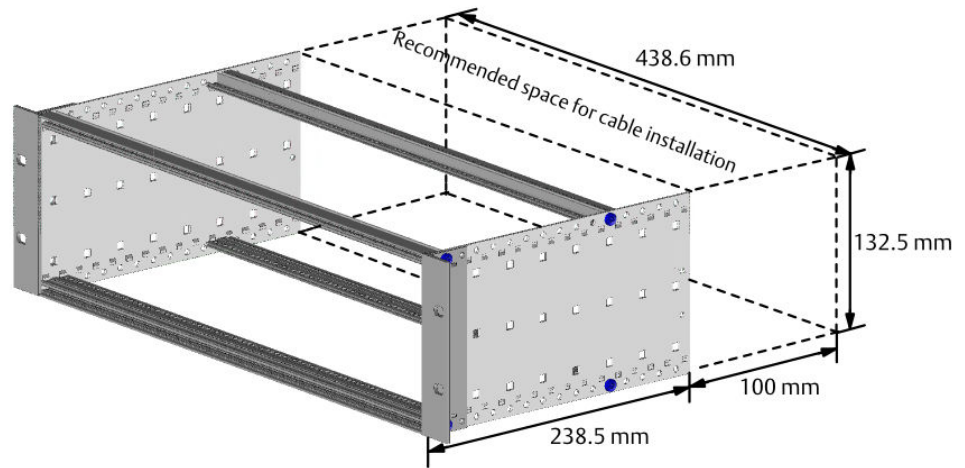
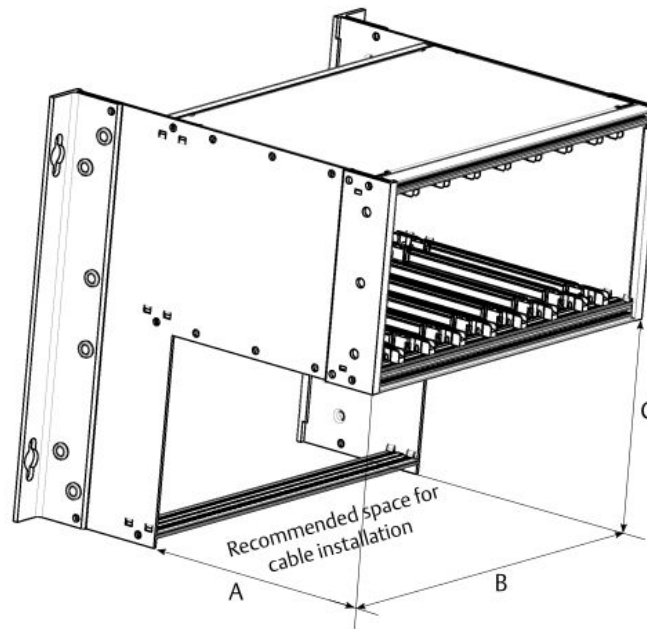

Figure 5-2: Dimensions terminal compartment – A6500-FR



- A. 153.5 mm
- B. 268.0 mm
- C. 132.5 mm

The cable glands must match the diameter of the used cables. The cable diameters are variable and must be considered.

Ensure a transition resistance of $<10^9 \Omega$ between frame of the system rack and potential equalization.

5.3 Connection requirements

The wire cross section of the used cables must be within the range of $0.34 < F < 2.5 \text{ mm}^2$. Use ferrules at stranded conductors.

Connect the shield of the Ethernet cable to ground at the remote station. If this is not possible, ground the shield using a shield clamp within the field housing. Integrate the grounding of all cable shields into the potential equalization system.

All used connectors (Ethernet, D-Sub, and the power supply terminals XR1 and XR2) must be locked. Only use the USB port of the A6500-CC Com Card and the SMB sockets "Sensor Signal 1" and "Sensor Signal 2" of the A6500-UM Universal Measurement Card at open field housing, which requires a hazard-free environment. It is not permitted to use other bridges than the provided bridges on the connectors for the supply XR1 and XR2. See red markings on [Figure 5-3](#) and [Figure 5-4](#).

Figure 5-3: Permitted bridge – A6500-SR and A6500-RR

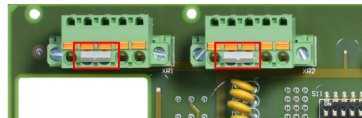
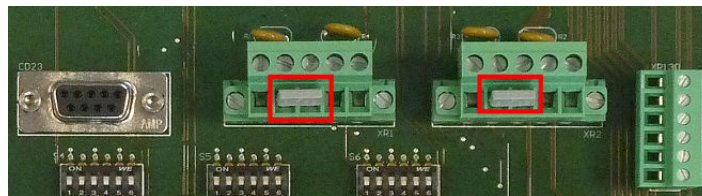

Figure 5-4: Permitted bridge – A6500-FR



You must connect the terminals of all live cables.

5.4 CSA - Special conditions of safe use

1. The modular rack based system AMS 6500 ATG shall be installed completely inside an additional enclosure, providing a degree of protection of not less than IP 54 according to CSA/UL 60079-0 and CSA/UL 60079-7.

Ambient temperature – A6500-SR and A6500-RR

The ambient temperature within the end use enclosure shall not exceed 55 °C.

The ambient temperature within the end use enclosure shall not exceed 70 °C if a fan tray with three fans and a minimum airflow volume of at least 440 m³/h is mounted directly on the bottom side of the rack.

Ambient temperature – A6500-FR

The ambient temperature within the end use enclosure shall not exceed 55 °C.

The ambient temperature within the end use enclosure shall not exceed 70 °C if a fan tray with two fans and a minimum airflow volume of at least 300 m³/h is mounted directly on the top side of the rack.

2. The USB port, the SMB connectors, and the slide switches shall be used in a safe area, known to be non-hazardous, only.
3. The end user shall ensure appropriate earthing upon installation.
4. Final acceptance of this equipment when installed is subject to the jurisdiction of the local inspection authority.

Observe the following warning notes attached to the device.

WARNING: EXPLOSION HAZARD - DO NOT CONNECT OR DISCONNECT WHILE CIRCUITS ARE LIVE UNLESS AREA IS KNOWN TO BE NON-HAZARDOUS

AVERTISSEMENT: RISQUE D'EXPLOSION- NE PAS CONNECTER OU DECONNECTER TANT QUE LES CIRCUITS SONT SUR TENSION SEULEMENT SI LA ZONE EST CONNU POUR ÊTRE NON DANGEREUX

WARNING: DO NOT USE USB PORT, SMB CONNECTORS OR SLIDSWITCHES UNLESS THE AREA IS KNOWN TO BE NON-HAZARDOUS

AVERTISSEMENT: NE PAS UTILISER PORT USB, CONNECTEURS SMB OU INTERUPTEUR COULISSANT SEULEMENT SI LA ZONE EST CONNU POUR ÊTRE NON DANGEREUX

5.5 Technical data, explosion protection

The A6500-SR, A6500-RR, and A6500-FR System Racks are checked and certified for the following, if connected to SELV/PELV - electrical circuits for use in potentially explosive atmospheres:

Explosion protection class

IECEX/ATEX/CSA		
Type of protection		non-sparking ec in combination with nC
Identification	IECEX/ATEX	II 3G - Ex ec nC IIC Gc
	CSA	Class I Division 2, Groups A, B, C, D, T4 Class 1, Zone 2 Ex/AEx ec nC IIC T4 Gc
Standards	IECEX	IEC 60079-0:2017 IEC 60079-7:2015/A1:2017
	ATEX	EN IEC 60079-0:2018 EN IEC 60079-7:2015/A1:2018

IECEX/ATEX/CSA	
CSA	CAN/CSA-C22.2 NO. 0-10 CAN/CSA-C22.2 NO. 61010-1-12 CAN/CSA-22.2 No. 60079-0:15 CAN/CSA-22.2 No. 60079-7 IEC 60529:2013 + COR2:2015 UL 61010-1:12 UL 60079-0:13 UL 60079-7
IECEX approval number	IECEX BVS 16.0012U
ATEX approval number	BVS 16 ATEX E 016 U
CSA approval number	CSA 16.70052580

A6500-SR and A6500-RR The operation of the system in an enclosure with temperatures of -20°C up to 55°C without forced convection and up to 70°C with forced convection according to the defined properties is permissible. Under these circumstances, the requirements according to the temperature class T4 are fulfilled and no permitted component service temperature is exceeded.

A6500-FR The operation of the system in an enclosure with temperatures of -20°C up to 55°C without forced convection and up to 70°C with forced convection according to the defined properties is permissible. Under these circumstances, the requirements according to the temperature class T4 are fulfilled and no permitted component service temperature is exceeded.

5.6 Control drawing – A6500-SR and A6500-RR

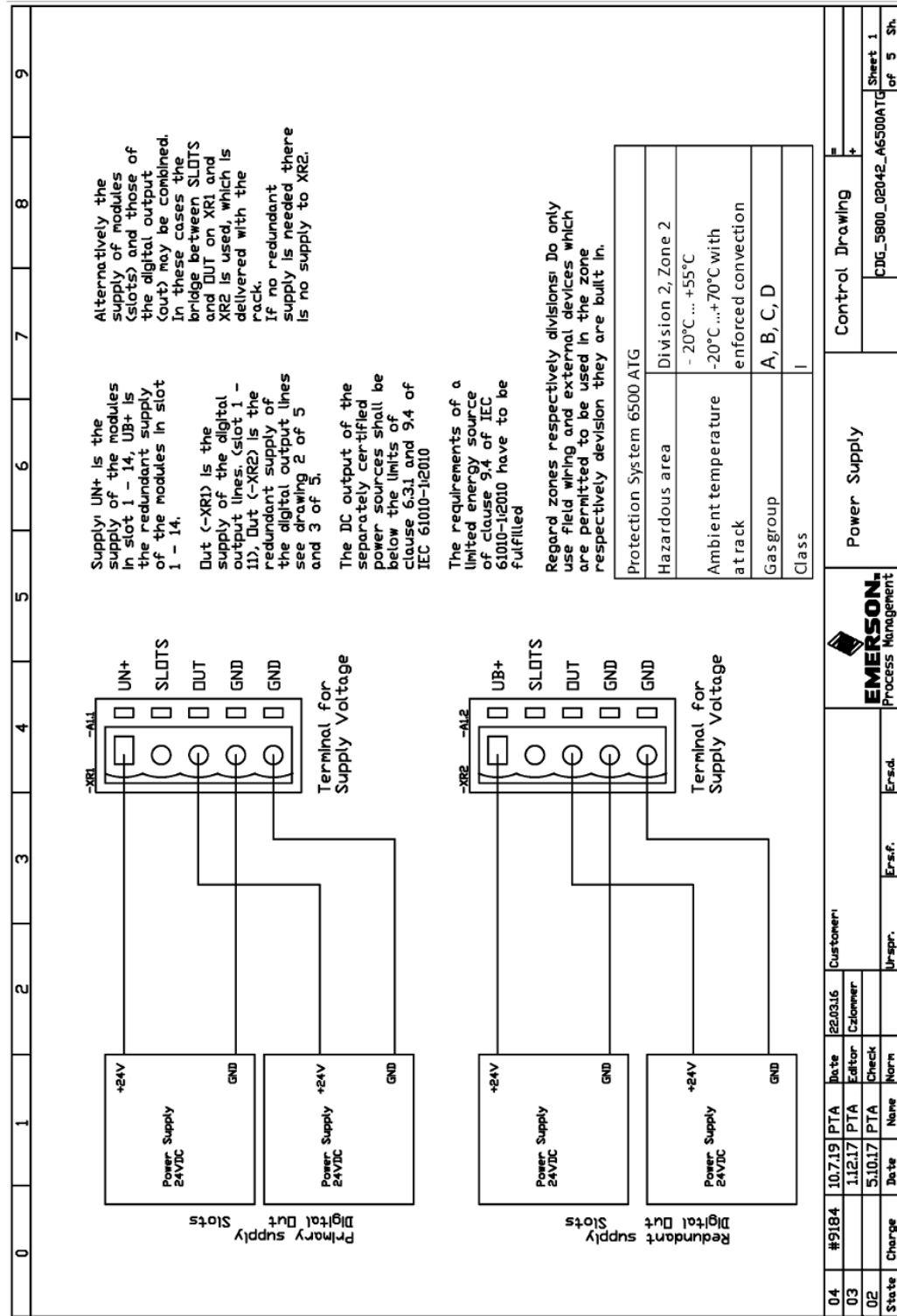

04	#9184	10.7.19	PTA	Date	22/03/16	Customer	
03		11.2.17	PTA	Editor			
02		5.10.17	PTA	Check			
State	Charge	Date	Name	Norm.	Er.spr.	Er.srd.	
							Control Drawing
Power Supply							CDG_5600_02042_A6500AIG
							Sheet 1 of 5 Sh.

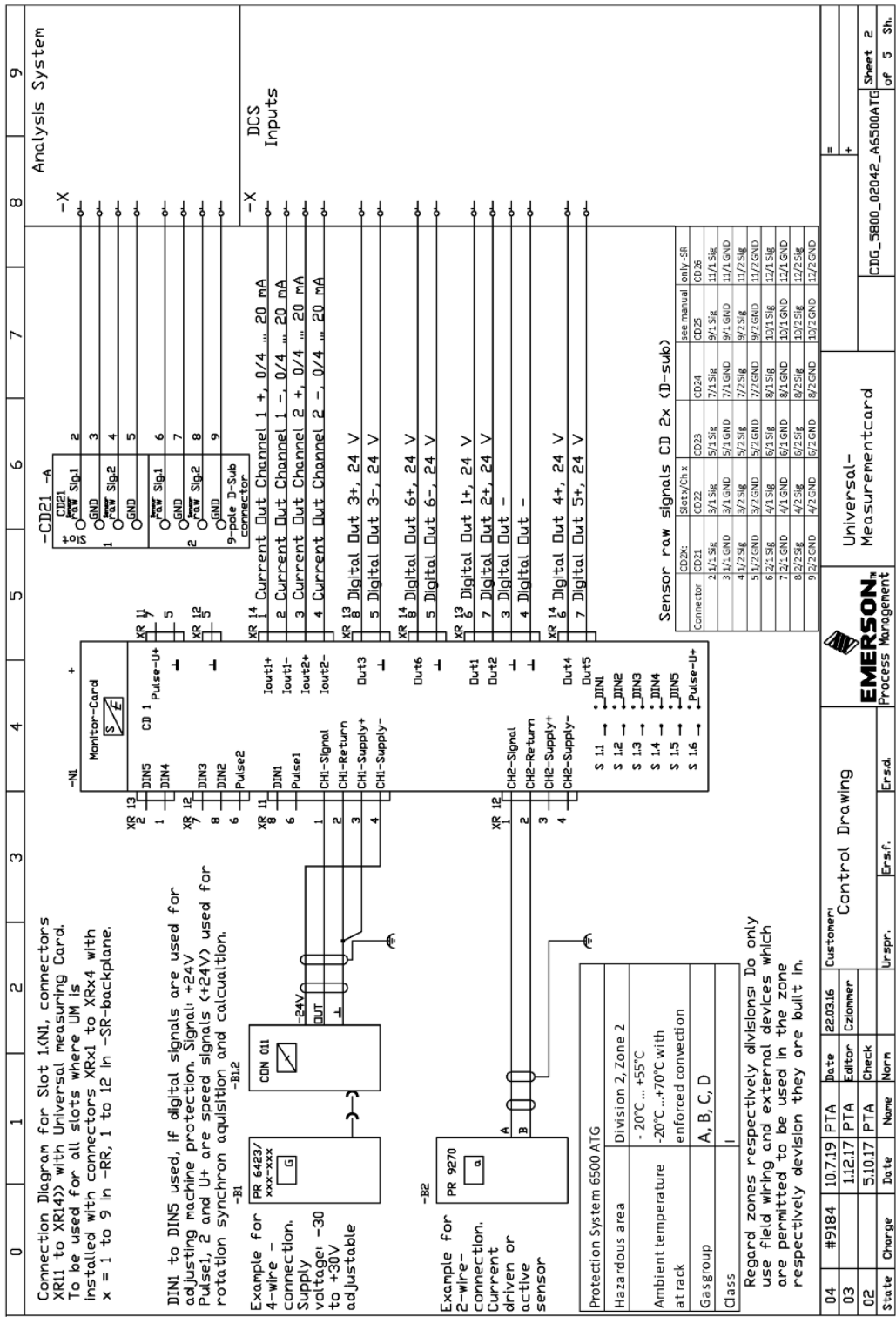

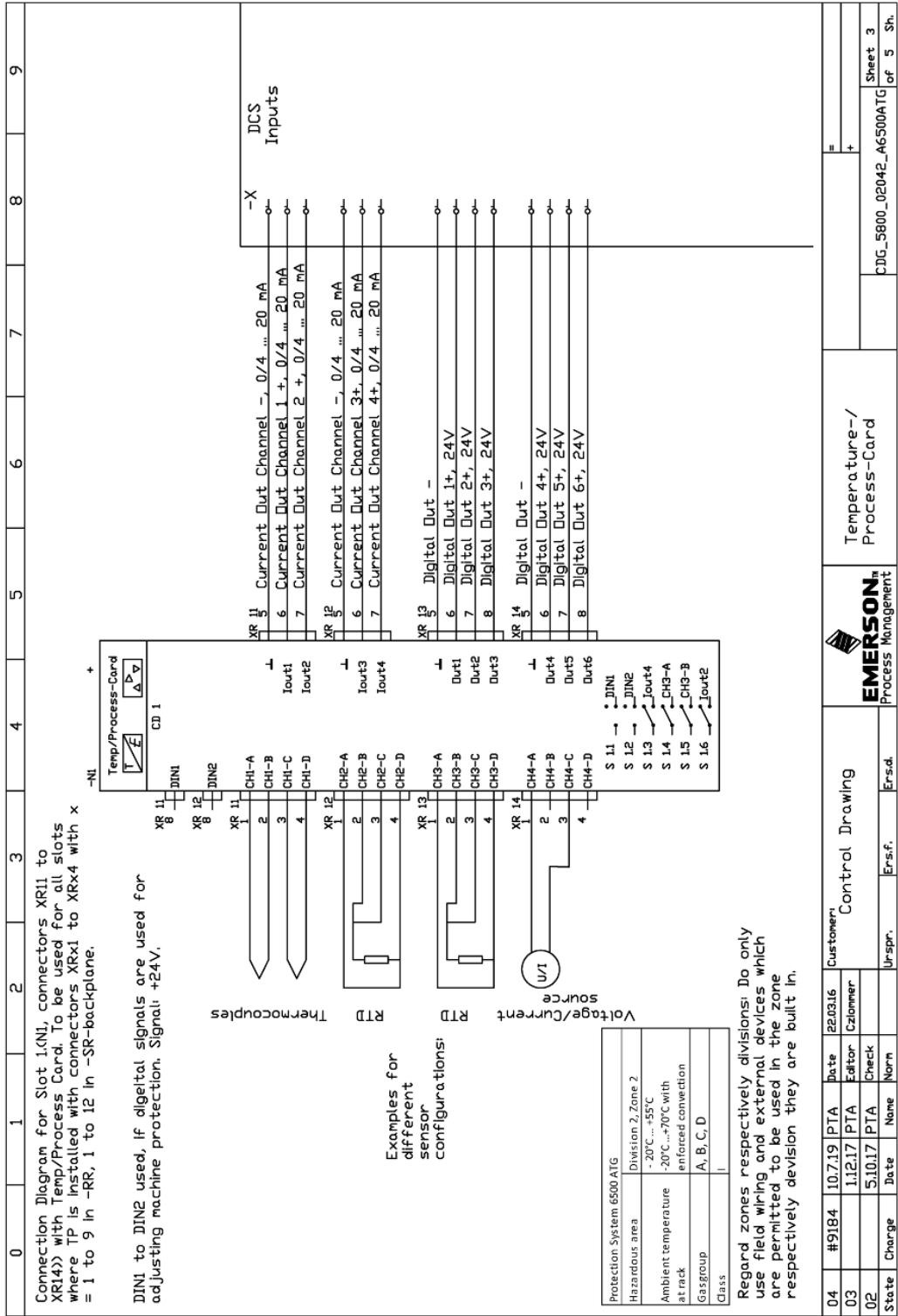

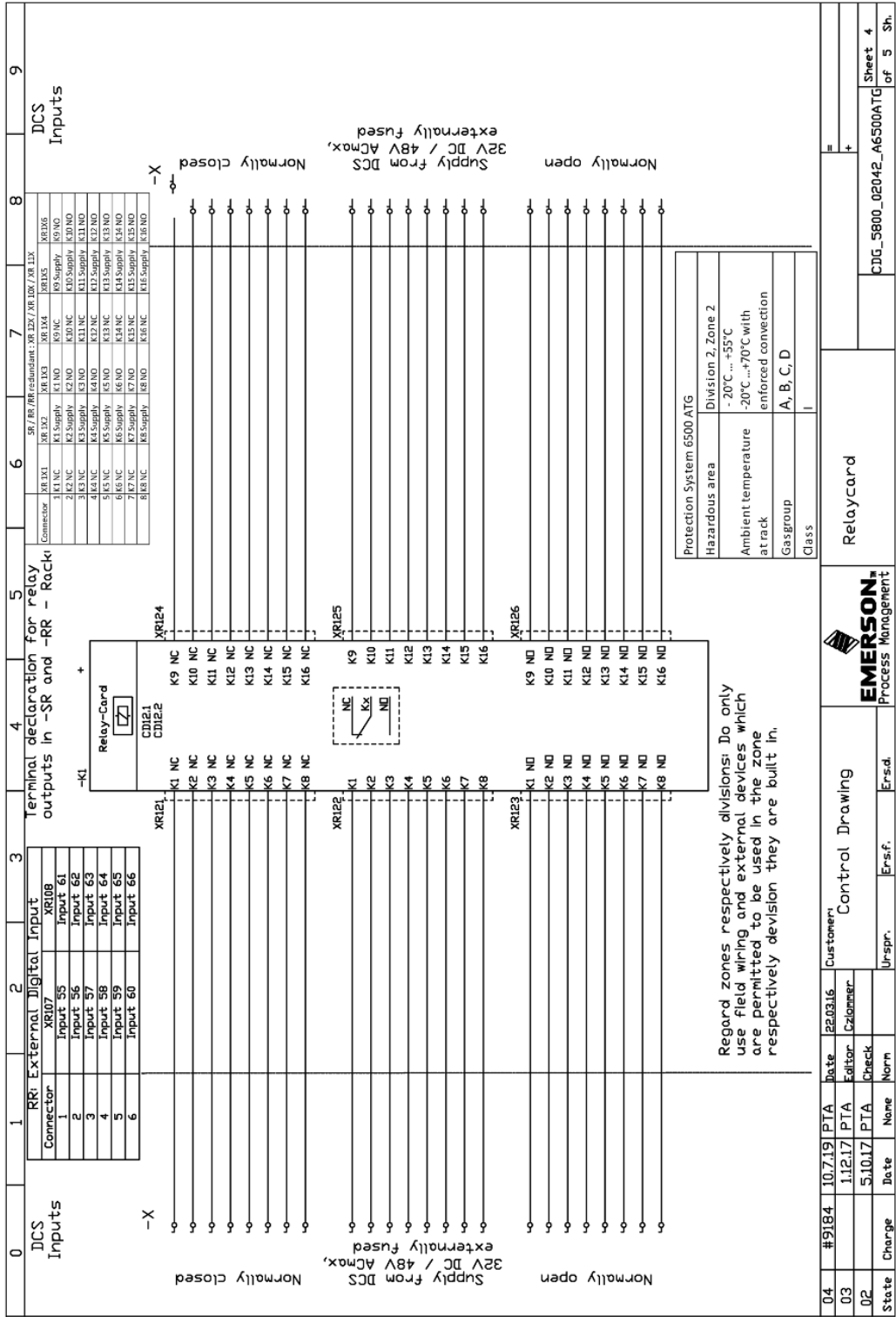

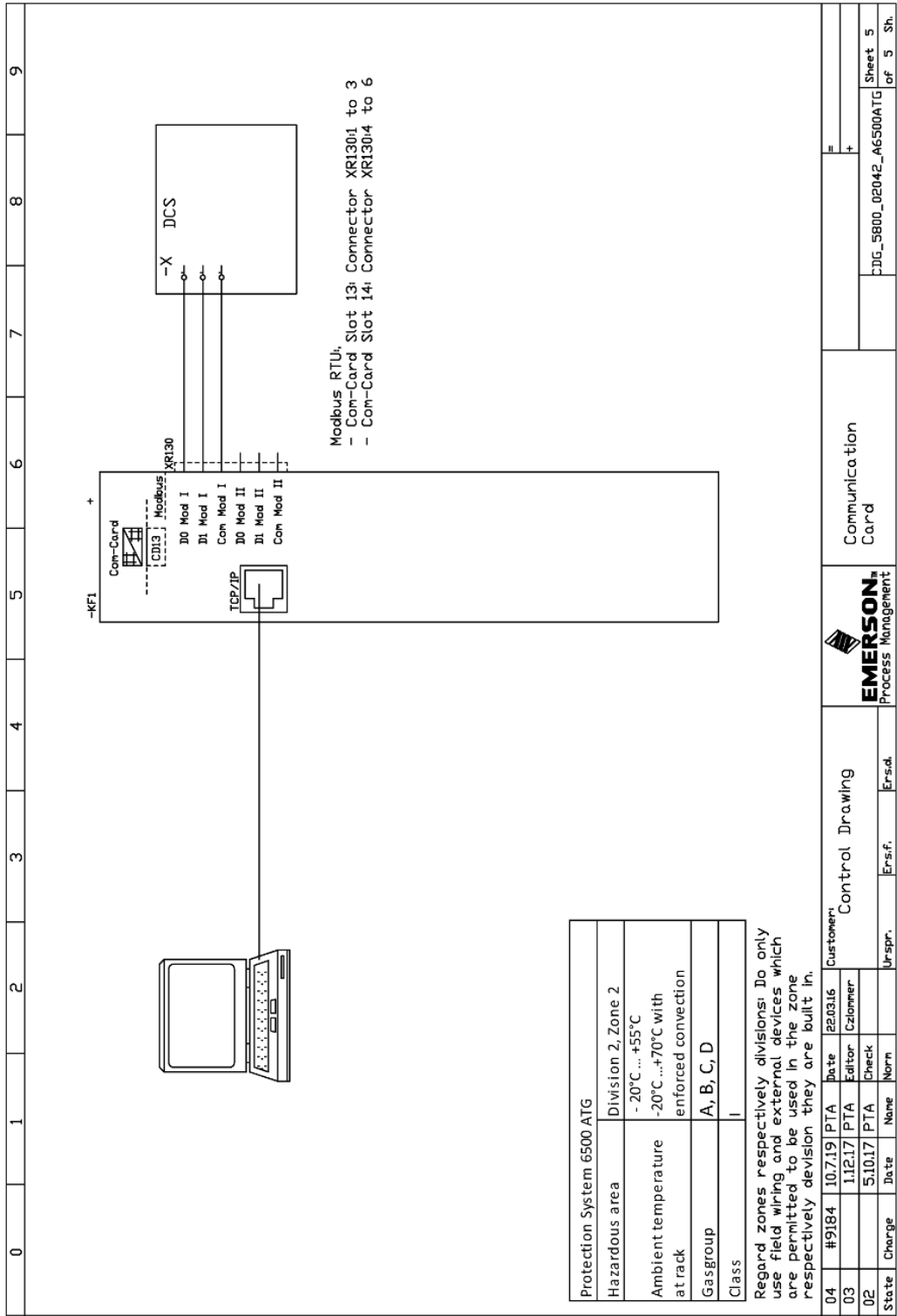

5.7 Control drawing – A6500-FR

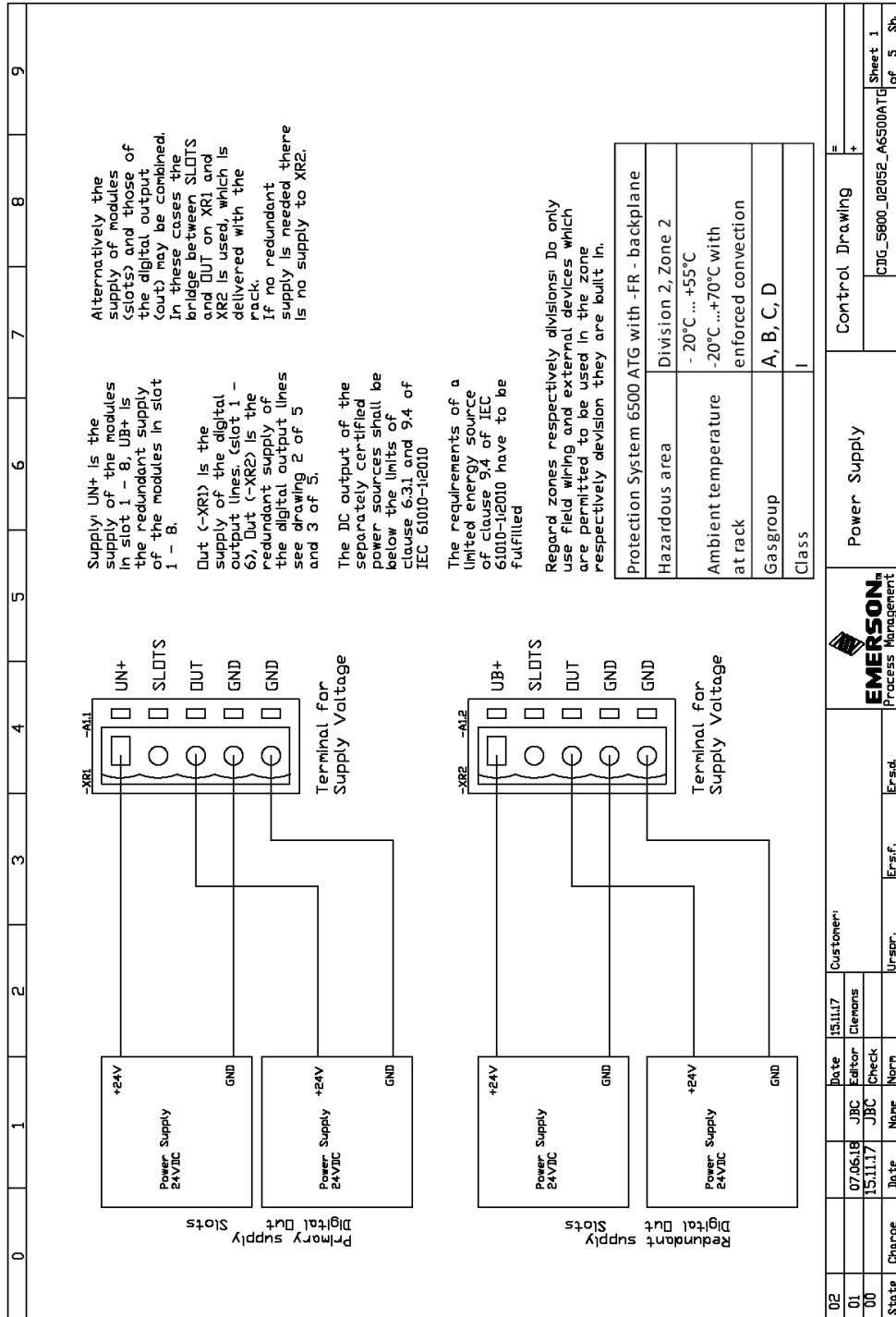

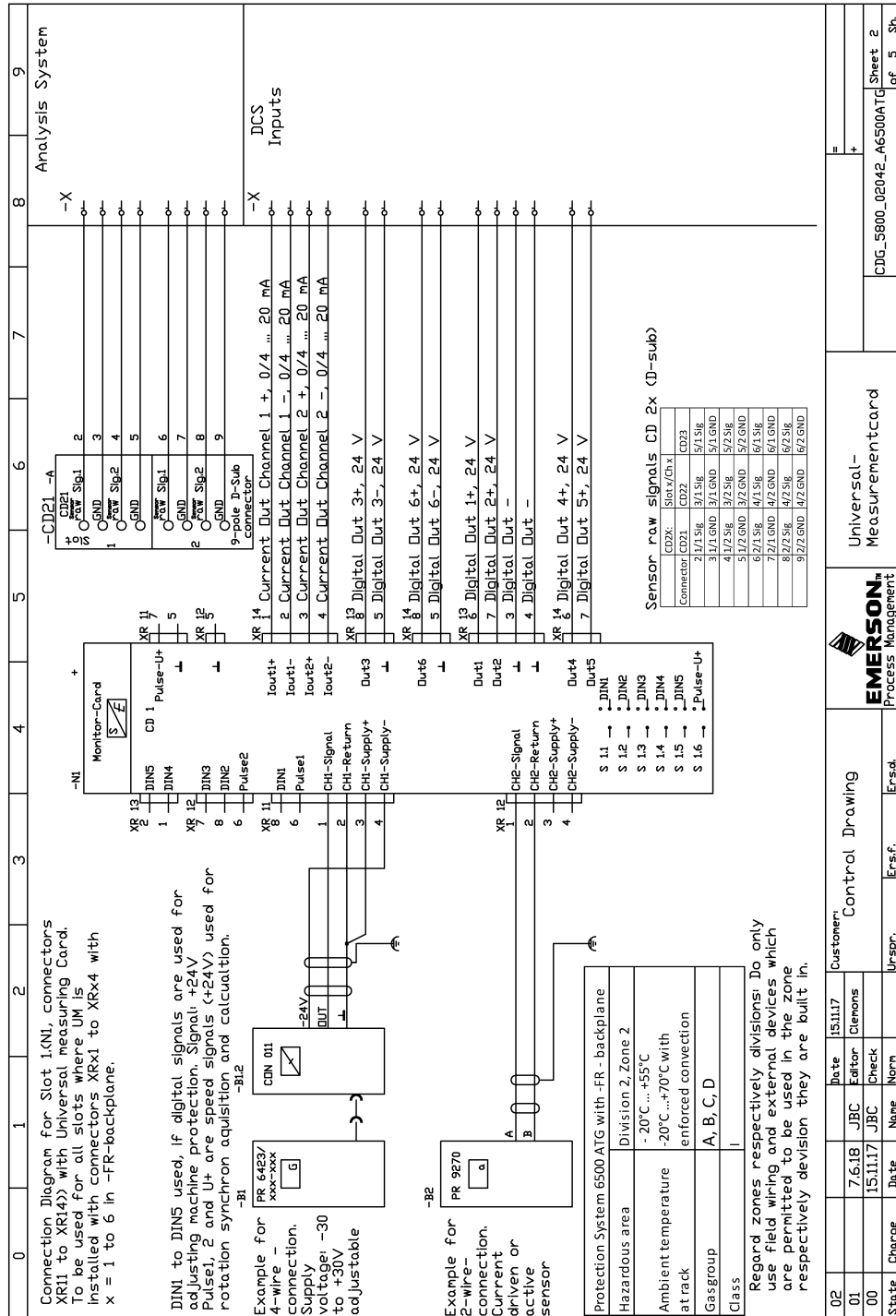

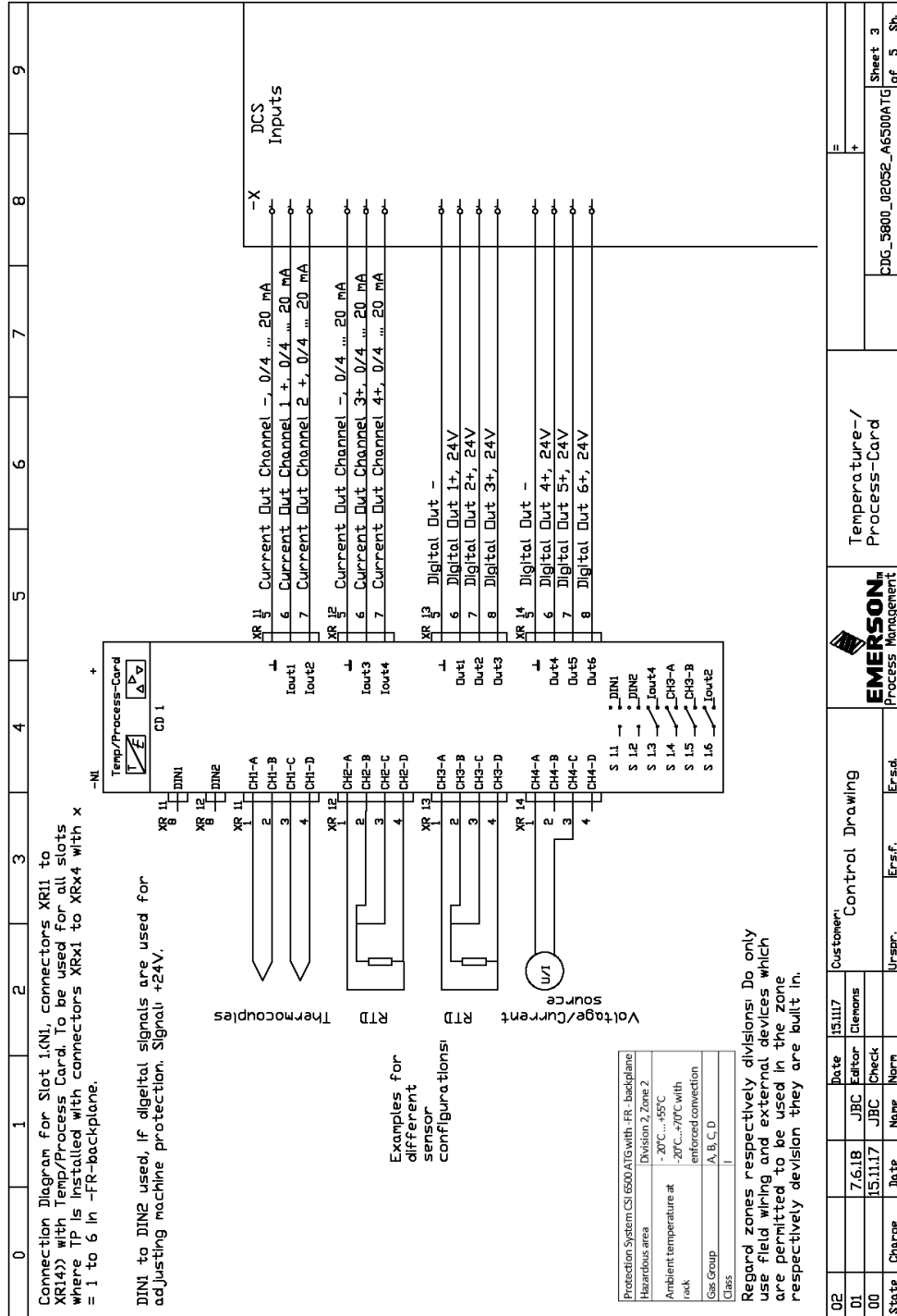

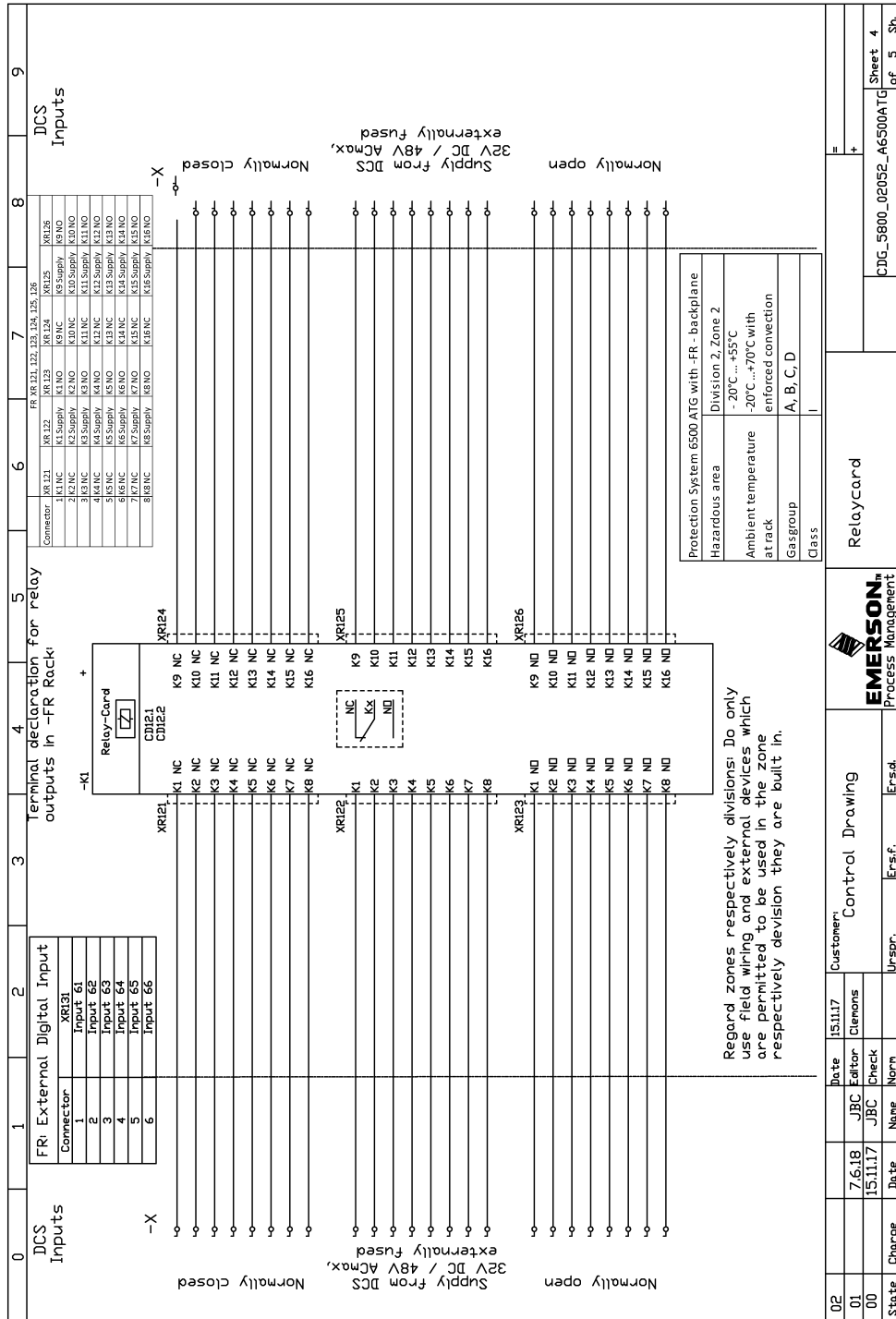

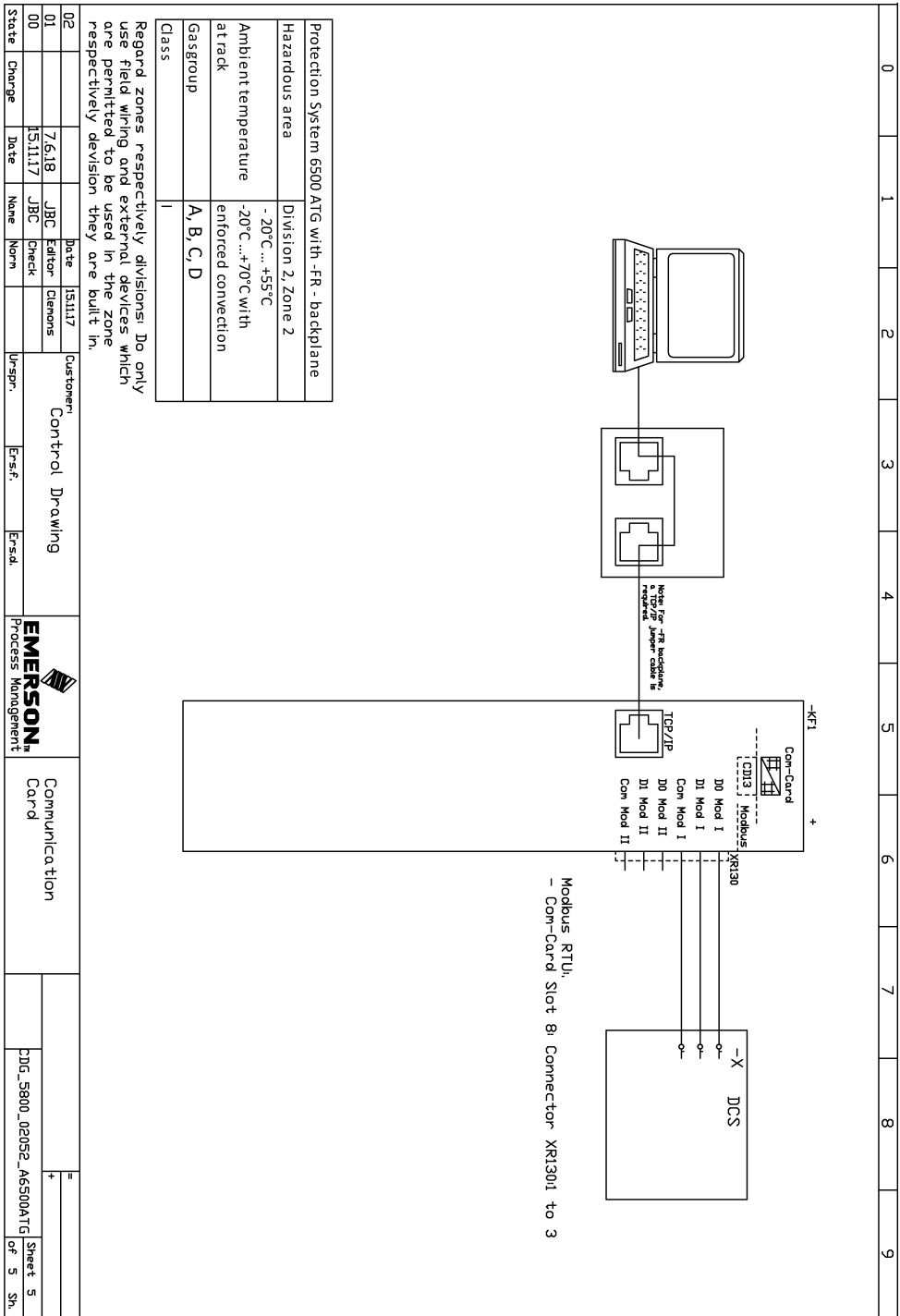

5.8 Revision history

Version	Date	Remarks/Changes
1.0	06. August 2015	Initial version
1.2	24. February 2016	Correction of chapter "Connection requirements"
1.3	09. May 2016	CSA parts added
1.4	18. May 2016	Warning notes
1.5	13. June 2017	Added A6500-RR System Rack and Control Drawing update
1.6	05. October 2017	CSA - Special conditions and Control Drawing update
1.7	04. December 2017	A6500-SR and A6500-RR Control Drawing update
1.8	12. December 2017	Added A6500-FR System Rack and Control Drawing update
1.9	11. July 2019	Update Control Drawings for A6500-SR, A6500-RR, and A6500-FR
1.10	8. March 2022	Standards and identification update

6 Maintenance

The A6500-FR, A6500-RR, and A6500-SR System Racks do not require any maintenance during normal operation.

7 Replace the System Rack

Follow the steps listed below if the System Rack needs to be replaced. For example, as a result of a defect.

⚠ CAUTION

Any work at the system may impair machine protection.

Procedure

1. Switch off the supply voltage.
2. Unfasten the mounting screws of all installed devices, and remove them from the slots.
3. Disconnect all screw terminal connectors and D-Sub connectors from the System Rack.
4. Remove the defective System Rack.
5. Set the slide switches of the new System Rack to match the slide switch settings of the defective System Rack.
6. Mount the new System Rack as described in [Mount the System Rack – A6500-SR and A6500-RR](#) (A6500-SR and A6500-RR) or [Mount the system rack – A6500-FR](#) (A6500-FR).
7. Reconnect all screw terminal connectors and D-Sub connectors.
8. Switch on the supply voltage.

8 Technical data

Only specifications with indicated tolerances or limit values are required. Data without tolerances or without error limits are informative data and not guaranteed. Technology is under constant development, and specifications are subject to change without notice. If not specified otherwise, all data are referred to an environmental temperature of +25°C.

8.1 Power supply

Table 8-1: Power Supply Specifications

Nominal supply voltage	+24 V DC	redundant (Slots and Out)
Limit	+19 V to +32 V DC	in case of a single failure, supply voltage must not exceed the level of IEC 60204-1 or IEC 61131-2 (SELV/PELV)
Rated current (Slots)	4 A	installed cards
Rated current (Out)	6 A	additional supply for external use of digital outputs
Rated power (Slots)	<100 W	installed cards
Rated power (Out)	<150 W	additional supply for external use of digital outputs

8.2 Slot distribution

Table 8-2: Slot Distribution Specifications

Number of measurement card slots (A6500-UM and A6500-TP)	11 (A6500-SR)	each slot 6HP
	9 (A6500-RR)	
	6 (A6500-FR)	
Number of Relay Card slots	1 (A6500-SR and A6500-FR)	each slot 10HP
	2 (A6500-RR)	
Number of COM Card slots	2 (A6500-SR and A6500-RR)	each slot 4HP (redundant)
	1 (A6500-FR)	4HP

8.3 Mechanical design and environmental conditions

Table 8-3: Mechanical Design Specifications

Dimensions	3RU/84HP (A6500-SR and A6500-RR)	conform to IEC 60297
------------	----------------------------------	----------------------

Table 8-3: Mechanical Design Specifications (continued)

	6RU/50HP (A6500-FR)	
Board coating	Airborne contaminants resistance	ISA-S71.04-1985 airborne contaminants class G3, Conformal Coating
	Material: HumiSeal® 1B31 EPA	according to IPC-CC-830B and IPC-A 610
Connector measurement card slot	type F48 female	according to IEC 60603-2
Connector relay card slot	type C96 female type F48 female	according to IEC 60603-2
Connector COM card	type C30 female	according to IEC 60603-2
Terminals power supply	2.5 mm ²	screw terminal connection ¹
Terminals I/O	1.5 mm ²	screw terminal connection ¹
D-Sub connector	D-Sub 9	shielded, UNC 4-40 screw lock
Weight	approximately 2600 g (A6500-SR and A6500-RR) approximately 2400 g (A6500-FR)	exclusive packaging

¹ Push-in spring cage connectors are an optional accessory.

Table 8-4: Environmental Conditions Specifications

Protection class	IP20	according to IEC 60529 rack mounted, otherwise IP00
Approval class for general safety	Class 2253 01	industrial automation products
	Class 2253 81	industrial automation products - (certified to U.S. standards)
Allowed degree of pollution	Category 2	according to IEC 61010-1
Operating temperature	-20°C to +70°C	with forced cooling ¹
	-20°C to +55°C	without forced cooling
Storage temperature	-40°C to +85°C	
Relative humidity	5 to 95%	noncondensing
Shock	150 m/s ²	according to IEC 60068-2-27, 4000 shocks per axis
Vibration	0.15 mm	10 to 55Hz
	20 m/s ²	55 to 150Hz according to IEC 60068-2-6, float sinus, three axis
Operating altitude	<2000 m	above sea level
Environmental area	Indoor use only	

Table 8-4: Environmental Conditions Specifications (continued)

External devices		in case of a single failure, externally connected devices must not exceed the level of IEC 60204-1 or IEC 61131-2
------------------	--	---

¹ An airflow of $\geq 440 \text{ m}^3/\text{h}$ is required.

9 Certificates



EU-Declaration of Conformity (Translation)

We: epro GmbH, Jöbkesweg 3, 48599 Gronau
declare under our sole responsibility that following product(s):

Product designation:	AMS 6500 ATG
Product description:	Protection system for rotating equipment with integrated prediction capabilities
Part numbers	A6500-CC A6500-UM A6500-TP A6500-RC A6500-SR A6500-RR A6500-FR

are in conformity with the terms of the directives mentioned below including any amendment valid at the date of declaration:

2014/30/EU	Electromagnetic compatibility
2014/34/EU	Equipment and protective system intended for use in potentially explosive atmospheres
2011/65/EU	The restriction of the use of certain hazardous substances in electrical and electronic equipment

Following harmonized standards have been applied:

2014/30/EU	EN 61326-1	Electrical equipment for measurement, control and laboratory use. EMC requirements.
2014/34/EU	EN 60079-0	Explosive atmospheres - Part 1: General requirements
		Part 0: Equipment - General requirements
	EN 60079-7	Explosive atmospheres - Part 7: Equipment protection by increased safety "e"
2011/65/EU	EN 63000	Technical documentation for the assessment of electrical and electronic products with respect to the restriction of hazardous substances

For the type examination according to EN 60079-0 and EN 60079-7 the following notified body has been involved;

DEKRA EXAM GmbH
Type examination certificate BVS 16 ATEX E 016 U

Authorized person for technical documentation:
Bruno Hecker, Jöbkesweg 3, 48599 Gronau

Gronau, 06 May 2022
Place, Date

Managing Director

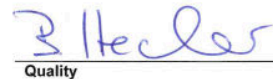
Quality



EU-Konformitätserklärung (Original)



Wir: epro GmbH, Jöbkesweg 3, 48599 Gronau
erklären in alleiniger Verantwortung, dass folgende Produkte:

Produktbezeichnung: AMS 6500 ATG
Produktbeschreibung: Schutzsystem für rotierende Maschinen mit integrierten Diagnosemöglichkeiten
Artikelnummern: A6500-CC
A6500-UM
A6500-TP
A6500-RC
A6500-SR
A6500-RR
A6500-FR

den Bestimmungen der unten genannten Richtlinien, einschließlich deren zum Zeitpunkt der Erklärung geltenden Änderungen, entsprechen:

2014/30/EU	Elektromagnetische Verträglichkeit
2014/34/EU	Geräte und Schutzsysteme zur bestimmungsgemäßen Verwendung in explosionsgefährdeten Bereichen
2011/65/EU	Beschränkung der Verwendung bestimmter gefährlicher Stoffe in Elektro- und Elektronikgeräten

Folgende harmonisierte Normen wurden angewandt:

2014/30/EU	EN 61326-1	Elektrische Mess-, Steuer-, Regel- und Laborgeräte – EMV Anforderungen - Teil 1: Allgemeine Anforderungen
2014/34/EU	EN 60079-0	Explosionsgefährdete Bereiche - Teil 0: Betriebsmittel – Allgemeine Anforderungen
	EN 60079-7	Explosionsgefährdete Bereiche - Teil 7: Geräteschutz durch erhöhte Sicherheit "e"
2011/65/EU	EN 63000	Technische Dokumentation zur Beurteilung von Elektro- und Elektronikgeräten hinsichtlich der Beschränkung gefährlicher Stoffe

Für die Baumusterprüfung nach EN 60079-0 und EN 60079-7 ist folgende Benannte Stelle eingeschaltet worden:

DEKRA EXAM GmbH
Baumusterprüfnummer BVS 16 ATEX E 016 U

Bevollmächtigter für die Technische Dokumentation:

Bruno Hecker, Jöbkesweg 3, 48599 Gronau

Gronau, 06. Mai 2022
Ort, Datum

Geschäftsführung
Qualitätsmanagement



UKCA-Declaration of Conformity

We, the manufacturer: epro GmbH, Jöbkesweg 3, 48599 Gronau, Germany
declare under our sole responsibility that following product(s):

Product designation:	AMS 6500 ATG
Product description:	Protection system for rotating equipment with integrated prediction capabilities
Part numbers	A6500-CC A6500-UM A6500-TP A6500-RC A6500-SR A6500-RR

are in conformity with the terms of the directives mentioned below including any amendment valid at the date of declaration:

S.I. 2016 No. 1091	Electromagnetic Compatibility Regulations 2016
S.I. 2016 No. 1107	Equipment and Protective Systems Intended for use in Potentially Explosive Atmospheres Regulations 2016
S.I. 2012 No. 3032	The restriction of the use of certain hazardous substances in electrical and electronic equipment

Following standards have been applied:

S.I. 2016 No. 1091	EN 61326-1	Electrical equipment for measurement, control and laboratory use. EMC requirements. Part 1. General requirements
S.I. 2016 No. 1107	EN 60079-0	Explosive atmospheres -Part 0: Equipment- General requirements
	EN 60079-7	Explosive atmospheres - Part 7: Equipment protection by increased safety "e"
S.I. 2012 No. 3032	EN IEC 63000	Technical documentation for the assessment of electrical and electronic products with respect to the restriction of hazardous substances

For the type examination according to EN 60079-0 and EN 60079-7 the following notified body has been involved:

DEKRA Testing and Certification GmbH
Type examination certificate BVS 16 ATEX E 016 X

Authorized person for technical documentation:

Bruno Hecker, Jöbkesweg 3, 48599 Gronau, Germany

Authorized Representative:

Emerson Process Management Limited,
company No 00671801
Meridian East,
Leicester
LE19 1UX, United Kingdom
Regulatory Compliance Department
email: ukproductcompliance@emerson.com
Phone: +44 11 6282 23 64

M. Fränzer
Managing Director

B. Hecker
Quality

Place, Date: Gronau, 13 September 2022



Emerson Process Management
1100 W. Louis Henna Blvd.
Round Rock, TX 78681

Statement Regarding the China RoHS Compliance of Emerson Product – A6500-UM

Please refer to Table 1 for the names and contents of the toxic or hazardous substances or elements contained in Emerson products.

Table 1: Names and Contents of Toxic or Hazardous Substances or Elements
表1：有毒有害物质或元素的名称及含量

部件名称 Part Name	有毒有害物质或元素 Toxic or hazardous Substances and Elements						
	铅 Lead (Pb)	汞 Mercury (Hg)	镉 Cadmium (Cd)	六价铬 Hexavalent Chromium (Cr (VI))	多溴联苯 Polybrominated biphenyls (PBB)	多溴二苯醚 Polybrominated diphenyl ethers (PBDE)	
印刷电路板组装 PC BD ASSY	X	0	0	0	0	0	
面板 FACEPLATE	0	0	0	0	0	0	
印刷电路板组装支持 PC BD ASSY SUPPORT	0	0	0	0	0	0	
<p>0 表示该有毒有害物质在该部件所有均质材料中的含量均在GB/T 26572规定的限量要求以下 0: Indicates that this toxic or hazardous substance contained in all of the homogeneous materials for this part is below the limit requirement in GB/T 26572.</p> <p>X 表示该有毒有害物质至少在该部件的某一均质材料中的含量超出GB/T 26572规定的限量要求。 X: Indicates that this toxic or hazardous substance contained in at least one of the homogeneous materials used for this part is above the limit requirement in GB/T 26572</p> <p>环保期限 (EFUP) 的产品及其部件是每个列出的符号，除非另有标明。使用期限只适用于产品在产品手册中规定的条件下工作 The Environmentally Friendly Period (EFUP) for the product and its parts are per the symbol listed, unless otherwise marked. Use Period is valid only when the product is operated under the conditions defined in the product manual.</p>							

James McFerrin
Environmental Compliance Manager PSG
T 512.832.3271 E james.mcferrin@emerson.com



Emerson Process Management
1100 W. Louis Henna Blvd.
Round Rock, TX 78681

Statement Regarding the China RoHS Compliance of Emerson Product – A6500-TP

Please refer to Table 1 for the names and contents of the toxic or hazardous substances or elements contained in Emerson products.

Table 1: Names and Contents of Toxic or Hazardous Substances or Elements
表1：有毒有害物质或元素的名称及含量

部件名称 Part Name	有毒有害物质或元素 Toxic or hazardous Substances and Elements						
	铅 Lead (Pb)	汞 Mercury (Hg)	镉 Cadmium (Cd)	六价铬 Hexavalent Chromium (Cr (VI))	多溴联苯 Polybrominated biphenyls (PBB)	多溴二苯醚 Polybrominated diphenyl ethers (PBDE)	
印刷电路板组装 PC BD ASSY	X	0	0	0	0	0	
面板 FACEPLATE	0	0	0	0	0	0	
印刷电路板组装支持 PC BD ASSY SUPPORT	0	0	0	0	0	0	
<p>0 表示该有毒有害物质在该部件所有均质材料中的含量均在GB/T 26572规定的限量要求以下 0: Indicates that this toxic or hazardous substance contained in all of the homogeneous materials for this part is below the limit requirement in GB/T 26572.</p> <p>X 表示该有毒有害物质至少在该部件的某一均质材料中的含量超出GB/T 26572规定的限量要求。 X: Indicates that this toxic or hazardous substance contained in at least one of the homogeneous materials used for this part is above the limit requirement in GB/T 26572</p> <p>环保期限 (EFUP) 的产品及其部件是每个列出的符号，除非另有标明，使用期限只适用于产品在产品手册中规定的条件下工作 The Environmentally Friendly Period (EFUP) for the product and its parts are per the symbol listed, unless otherwise marked. Use Period is valid only when the product is operated under the conditions defined in the product manual.</p>							

James McFerrin
Environmental Compliance Manager PSG
T 512.832.3271 E james.mcferrin@emerson.com



Emerson Process Management
1100 W. Louis Henna Blvd.
Round Rock, TX 78681

Statement Regarding the China RoHS Compliance of Emerson Product – A6500-RC

Please refer to Table 1 for the names and contents of the toxic or hazardous substances or elements contained in Emerson products.

Table 1: Names and Contents of Toxic or Hazardous Substances or Elements
表1：有毒有害物质或元素的名称及含量

部件名称 Part Name	有毒有害物质或元素 Toxic or hazardous Substances and Elements						
	铅 Lead (Pb)	汞 Mercury (Hg)	镉 Cadmium (Cd)	六价铬 Hexavalent Chromium (Cr (VI))	多溴联苯 Polybrominated biphenyls (PBB)	多溴二苯醚 Polybrominated diphenyl ethers (PBDE)	
印刷电路板组装 PC BD ASSY	X	0	0	0	0	0	
面板 FACEPLATE	0	0	0	0	0	0	
印刷电路板组装支持 PC BD ASSY SUPPORT	0	0	0	0	0	0	
<p>0 表示该有毒有害物质在该部件所有均质材料中的含量均在GB/T 26572规定的限量要求以下 0: Indicates that this toxic or hazardous substance contained in all of the homogeneous materials for this part is below the limit requirement in GB/T 26572.</p> <p>X 表示该有毒有害物质至少在该部件的某一均质材料中的含量超出GB/T 26572规定的限量要求。 X: Indicates that this toxic or hazardous substance contained in at least one of the homogeneous materials used for this part is above the limit requirement in GB/T 26572</p> <p>环保期限 (EFUP) 的产品及其部件是每个列出的符号，除非另有标明。使用期限只适用于产品在产品手册中规定的条件下工作 The Environmentally Friendly Period (EFUP) for the product and its parts are per the symbol listed, unless otherwise marked. Use Period is valid only when the product is operated under the conditions defined in the product manual.</p>							

James McFerrin
Environmental Compliance Manager PSG
T 512.832.3271 E james.mcferrin@emerson.com



Emerson Process Management
1100 W. Louis Henna Blvd.
Round Rock, TX 78681

Statement Regarding the China RoHS Compliance of Emerson Product – A6500-CC

Please refer to Table 1 for the names and contents of the toxic or hazardous substances or elements contained in Emerson products.

Table 1: Names and Contents of Toxic or Hazardous Substances or Elements
表1：有毒有害物质或元素的名称及含量

部件名称 Part Name	有毒有害物质或元素 Toxic or hazardous Substances and Elements						
	铅 Lead (Pb)	汞 Mercury (Hg)	镉 Cadmium (Cd)	六价铬 Hexavalent Chromium (Cr (VI))	多溴联苯 Polybrominated biphenyls (PBB)	多溴二苯醚 Polybrominated diphenyl ethers (PBDE)	
印刷电路板组装 PC BD ASSY	X	0	0	0	0	0	
面板 FACEPLATE	0	0	0	0	0	0	
印刷电路板组装支持 PC BD ASSY SUPPORT	0	0	0	0	0	0	
<p>0 表示该有毒有害物质在该部件所有均质材料中的含量均在GB/T 26572规定的限量要求以下 0: Indicates that this toxic or hazardous substance contained in all of the homogeneous materials for this part is below the limit requirement in GB/T 26572.</p> <p>X 表示该有毒有害物质至少在该部件的某一均质材料中的含量超出GB/T 26572规定的限量要求。 X: Indicates that this toxic or hazardous substance contained in at least one of the homogeneous materials used for this part is above the limit requirement in GB/T 26572</p> <p>环保期限 (EFUP) 的产品及其部件是每个列出的符号，除非另有标明。使用期限只适用于产品在产品手册中规定的条件下工作 The Environmentally Friendly Period (EFUP) for the product and its parts are per the symbol listed, unless otherwise marked. Use Period is valid only when the product is operated under the conditions defined in the product manual.</p>							

James McFerrin
Environmental Compliance Manager PSG
T 512.832.3271 E james.mcferrin@emerson.com



Emerson Process Management
1100 W. Louis Henna Blvd.
Round Rock, TX 78681

Statement Regarding the China RoHS Compliance of Emerson Product – A6500-SR

Please refer to Table 1 for the names and contents of the toxic or hazardous substances or elements contained in Emerson products.

Table 1: Names and Contents of Toxic or Hazardous Substances or Elements
表1：有毒有害物质或元素的名称及含量

部件名称 Part Name	有毒有害物质或元素 Toxic or hazardous Substances and Elements						
	铅 Lead (Pb)	汞 Mercury (Hg)	镉 Cadmium (Cd)	六价铬 Hexavalent Chromium (Cr (VI))	多溴联苯 Polybrominated biphenyls (PBB)	多溴二苯醚 Polybrominated diphenyl ethers (PBDE)	
印刷电路板组装 PC BD ASSY	X	0	0	0	0	0	
围堰 ENCLOSURE	0	0	0	0	0	0	
硬件 HARDWARE	0	0	0	0	0	0	
印刷电路板组装支持 PC BD ASSY SUPPORT	0	0	0	0	0	0	
0 表示该有毒有害物质在该部件所有均质材料中的含量均在GB/T 26572规定的限量要求以下 0: Indicates that this toxic or hazardous substance contained in all of the homogeneous materials for this part is below the limit requirement in GB/T 26572.							
X 表示该有毒有害物质至少在该部件的某一均质材料中的含量超出GB/T 26572规定的限量要求。 X: Indicates that this toxic or hazardous substance contained in at least one of the homogeneous materials used for this part is above the limit requirement in GB/T 26572.							
环保期限 (EFUP) 的产品及其部件是每个列出的符号，除非另有标明。使用期限只适用于产品在产品手册中规定的条件下工作 The Environmentally Friendly Period (EFUP) for the product and its parts are per the symbol listed, unless otherwise marked. Use Period is valid only when the product is operated under the conditions defined in the product manual.							

James McFerrin
Environmental Compliance Manager PSG
T 512 832 3271 E james.mcferrin@emerson.com



Emerson Process Management
1100 W. Louis Henna Blvd.
Round Rock, TX 78681

Statement Regarding the China RoHS Compliance of Emerson Product – A6500-RR

Please refer to Table 1 for the names and contents of the toxic or hazardous substances or elements contained in Emerson products.

Table 1: Names and Contents of Toxic or Hazardous Substances or Elements

表1：有毒有害物质或元素的名称及含量

部件名称 Part Name	有毒有害物质或元素 Toxic or hazardous Substances and Elements						
	铅 Lead (Pb)	汞 Mercury (Hg)	镉 Cadmium (Cd)	六价铬 Hexavalent Chromium (Cr (VI))	多溴联苯 Polybrominated biphenyls (PBB)	多溴二苯醚 Polybrominated diphenyl ethers (PBDE)	
印刷电路板组装 PC BD ASSY	X	0	0	0	0	0	
围堵 ENCLOSURE	0	0	0	0	0	0	
硬件 HARDWARE	0	0	0	0	0	0	
印刷电路板组装支持 PC BD ASSY SUPPORT	0	0	0	0	0	0	
<p>O 表示该有毒有害物质在该部件所有均质材料中的含量均在GB/T 26572规定的限量要求以下 O: Indicates that this toxic or hazardous substance contained in all of the homogeneous materials for this part is below the limit requirement in GB/T 26572.</p> <p>X 表示该有毒有害物质至少在该部件的某一均质材料中的含量超出GB/T 26572规定的限量要求。 X: Indicates that this toxic or hazardous substance contained in at least one of the homogeneous materials used for this part is above the limit requirement in GB/T 26572</p> <p>环保期限（EFUP）的产品及其部件是每个列出的符号，除非另有标明，使用期限只适用于产品在产品手册中规定的条件下工作 The Environmentally Friendly Period (EFUP) for the product and its parts are per the symbol listed, unless otherwise marked. Use Period is valid only when the product is operated under the conditions defined in the product manual.</p>							

James McFerrin
Environmental Compliance Manager PSG
T 512 832 3271 E james.mcferrin@emerson.com



Emerson Automation Solutions
1100 W. Louis Henna Blvd.
Round Rock, TX 78681

Statement Regarding the China RoHS Compliance of Emerson Product - A6500-FR

Please refer to Table 1 for the names and contents of the toxic or hazardous substances or elements contained in Emerson products.

Table 1: Names and Contents of Toxic or Hazardous Substances or Elements

表1：有毒有害物质或元素的名称及含量

部件名称 Part Name	有毒有害物质或元素 Toxic or hazardous Substances and Elements						
	铅 Lead (Pb)	汞 Mercury (Hg)	镉 Cadmium (Cd)	六价铬 Hexavalent Chromium (Cr (VI))	多溴联苯 Polybrominated biphenyls (PBB)	多溴二苯醚 Polybrominated diphenyl ethers (PBDE)	
印刷电路板组装 PC BD ASSY	X	0	0	0	0	0	
硬件 HARDWARE	0	0	0	0	0	0	
<p>0 表示该有毒有害物质在该部件所有均质材料中的含量均在GB/T 26572规定的限量要求以下 0: Indicates that this toxic or hazardous substance contained in all of the homogeneous materials for this part is below the limit requirement in GB/T 26572.</p> <p>X 表示该有毒有害物质至少在该部件的某一均质材料中的含量超出GB/T 26572规定的限量要求。 X: Indicates that this toxic or hazardous substance contained in at least one of the homogeneous materials used for this part is above the limit requirement in GB/T 26572</p> <p>环保期限 (EFUP) 的产品及其部件是每个列出的符号，除非另有标明。使用期限只适用于产品在产品手册中规定的条件下工作 The Environmentally Friendly Period (EFUP) for the product and its parts are per the symbol listed, unless otherwise marked. Use Period is valid only when the product is operated under the conditions defined in the product manual.</p>							

James McFerrin
Environmental Compliance Manager
Systems and Solutions
T 512 832 3271 E james.mcferrin@emerson.com



Emerson Automation Solutions
1100 W. Louis Henna Blvd.
Round Rock, TX 78681

Statement Regarding the China RoHS Compliance of Emerson Product - A6500-PE

Please refer to Table 1 for the names and contents of the toxic or hazardous substances or elements contained in Emerson products.

Table 1: Names and Contents of Toxic or Hazardous Substances or Elements

表1：有毒有害物质或元素的名称及含量

部件名称 Part Name	有毒有害物质或元素 Toxic or hazardous Substances and Elements						
	铅 Lead (Pb)	汞 Mercury (Hg)	镉 Cadmium (Cd)	六价铬 Hexavalent Chromium (Cr (VI))	多溴联苯 Polybrominated biphenyls (PBB)	多溴二苯醚 Polybrominated diphenyl ethers (PBDE)	
印刷电路板组装 C PC BD ASSY C	X	0	0	0	0	0	
印刷电路板组装 PC BD ASSY	X	0	0	0	0	0	
硬件 HARDWARE	0	0	0	0	0	0	
0 表示该有毒有害物质在该部件所有均质材料中的含量均在GB/T 26572规定的限量要求以下 0: Indicates that this toxic or hazardous substance contained in all of the homogeneous materials for this part is below the limit requirement in GB/T 26572.							
X 表示该有毒有害物质至少在该部件的某一均质材料中的含量超出GB/T 26572规定的限量要求。 X: Indicates that this toxic or hazardous substance contained in at least one of the homogeneous materials used for this part is above the limit requirement in GB/T 26572							
环保期限 (EFUP) 的产品及其部件是每个列出的符号，除非另有标明。使用期限只适用于产品在产品手册中规定的条件下工作 The Environmentally Friendly Period (EFUP) for the product and its parts are per the symbol listed, unless otherwise marked. Use Period is valid only when the product is operated under the conditions defined in the product manual.							

James McFerrin
Environmental Compliance Manager
Systems and Solutions
T 512 832 3271 E james.mcferrin@emerson.com

Emerson
12001 Technology Drive
Eden Prairie, MN 55344 USA
T 1(952)828-3000
www.Emerson.com

Emerson
835 Innovation Drive
Knoxville, TN 37932 USA
T +1 865-675-2400
F +1 865-218-1401
www.Emerson.com

Emerson
Jöbkesweg 3
48599 Gronau
Germany
T +49 2562 709 0
F +49 2562 709 401
www.Emerson.com/ams

©2024, Emerson. All rights reserved.

The contents of this publication are presented for informational purposes only, and while diligent efforts were made to ensure their accuracy, they are not to be construed as warranties or guarantees, express or implied, regarding the products or services described herein or their use or applicability. All sales are governed by our terms and conditions, which are available on request. We reserve the right to modify or improve the designs or specifications of our products at any time without notice.

The Emerson logo is a trademark and service mark of Emerson Electric Co. The AMS logo is a mark of one of the Emerson family of companies. All other marks are the property of their respective owners.

