



Automate your valves with the
trusted Bettis family of actuators

Bettis™ RPX-Series Rack and Pinion Pneumatic Actuators
Reliable and cost effective



You're concerned about unreliable actuators affecting the efficiency of your plant

Reliability is always the first requirement in any facility. Most of the time, you will have to go through difficult selection on wide offerings of pneumatic and electric products in the market to ensure your choice will match your precise requirements of each installation. At the same time, cost is always part of the criteria during the selection process. To maintain productivity and profitability, you need to ensure your equipment are able to function with years of trouble-free operation and easy installation throughout the lifecycle.

“As much as 43% of unplanned downtime is caused by equipment failure.”

–Large Property Damage Losses in the Hydrocarbon-Chemical Industries, 17th Edition, David Mahoney, p. 3



“Lost production can equate to between 60 to 90% of total maintenance costs in process industries.”

–Maintenance Performance Assessment - Strategies and Indicators, in Department of Production Economic, Hagery, M. and M. Johansen





Instead of being distracted by constant challenges, what if you could improve productivity in a cost effective way while protecting the people and environment?

Bettis RPX-Series

Over 40 years of design experience provides true dollar per torque value



Bettis RPX-Series rack and pinion actuators are designed to automate the most popular quarter turn valves like ball, butterfly and plug valves and are easily adaptable for almost any other quarter turn (90° rotation) application.

The RPX-Series are constructed from high quality extruded aluminium and with end caps from cast aluminium. The actuator body is “glass blasted” and end caps are powder coated to provide a unique aesthetically pleasing satin finish.

Built using quality assurance methods according to ISO 9001 and manufactured to comply with the latest European directives like ATEX and PED, the RPX actuators can be operated with dry or lubricated air or non-corrosive gas and will operate continuously at pressures up to 8 bar / 120 psi. Capable of withstanding a wide range of temperatures between -20°C to +80°C/-4°F to 176°F. These actuators will provide years of service for indoor and outdoor applications.

Dual travel stops mounted near the top of the pinion allow for fine adjustment to the opening and closing strokes ensuring that valve operations are confirmed as fully open or closed. This feature also allows for re-configuration at site or in the workshop.





RPX has corrosion protection meeting with international industry standard requirements. Quality materials of construction and manufactured with state-of-the-art techniques makes the RPX a superior, long-lasting product.

Dual travel stops for accurate valve position adjustments

- Dual travel stops allow for fine adjustment of the open and closed positions.
- The nominal stroke (90°) has an adjustable range of $\pm 5^\circ$ at each end of travel.
- Optional end cap stroke limiter available

Reliability

- Springs are specially designed for a long cycle life.
- Equipped with individual spring cartridges allowing safe and quick conversion of spring sets to match your torque and pressure requirements.
- Double rack and pinion design nullifies side loads on the pinion shaft, minimizing bearing wear and extending life.
- Bearings are designed for lower bearing forces and a longer cycle life.

Designed for trouble-free cycle life

- Equipped with O-ring seals, low-friction piston and pinion bearing materials and grease for a low maintenance and trouble-free cycle life.
- Optimum corrosion resistance is achieved with anodized housing, zinc plated/chromated pinion, powder coated end caps, chromated pistons and stainless steel fasteners.
- Successful completion of a salt spray test according to ASTM 117B.

Global product safety requirements

- Complies with the latest European directives like ATEX (2014/34/EU), and PED (2014/68/EU) for use in a wide range of industrial applications.
- Flexible and cost effective valve mounting is achieved by fitting the valve flange with 2x ISO drilling patterns and fits the pinion with a Star Drive for both ISO5211 and DIN3337 installations.
- Standard NAMUR (VDI/VDE3845) equipment can be mounted to the solenoid and top accessory flanges.

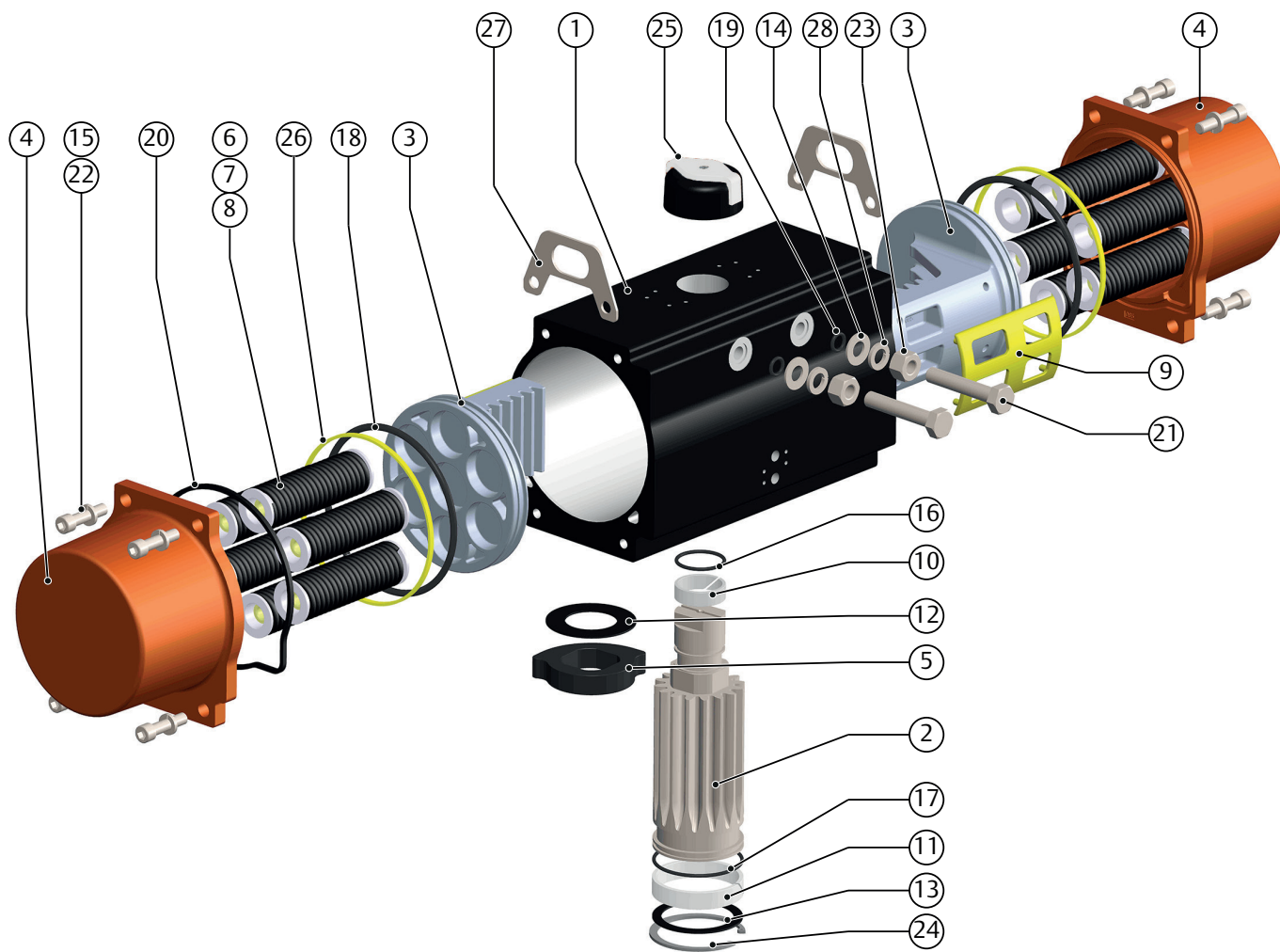

Construction Parts and Materials

Pos.	Description	Material	Notes
1	Body	Extruded Aluminium	3
2	Pinion	Hot rolled carbon steel	4
3	Piston	Die cast aluminium alloy	5
4	End cap	Die cast aluminium alloy	6
5	Cam	Cast grade SAE 1045/C45/ EN8	7
6	Spring	Spring steel	8
7	Spring retainer	Carbon steel	9
8	Spring cup	Polyamide grade 66 (up size 52) Die cast aluminium alloy (Size 84 and larger)	5
9	Piston guide	Zytel 101F NCO10	1
10	Top bearing	POM Acetal Resin	1
11	Bottom bearing	POM Acetal Resin	1
12	Top thrust washer	Polyamide grade 66	1
13	Bottom thrust washer	Polyamide grade 66	1
14	Travel stop washer	SS ISO 3506 A2-70 grade	2

Pos.	Description	Material	Notes
15	End cap washer	SS ISO 3506 A2-70 grade	2
16	O-ring pinion top	NBR shore 70 A	1
17	O-ring pinion bottom	NBR shore 70 A	1
18	O-ring Piston	NBR shore 70 A	1
19	O-ring travel stop	NBR shore 70 A	1
20	Gasket end cap	NBR shore 70 A	1
21	Travel stop screw	SS ISO 3506 A2-70 grade	2
22	End cap screw	SS ISO 3506 A2-70 grade	2
23	Travel stop nut	SS ISO 3506 A2-70 grade	2
24	Circlip	Carbon steel	1 / 4
25	Indicator assy	ABS + SS A2-70 grade screw	
26	Piston head guide	Zytel 101F NCO10	1 / 10
27	Lifting eyes	SS ISO 3506 A2-70 grade	9 / 10
28	Travel stop lock washer	SS ISO 3506 A2-70 grade	2

Notes:

- Included in repair kits
- SS = Stainless steel
- Anodized: 5-8 microns + ESPC 60-130 microns
- Zinc-Nickel plated: 8-12 microns
- Anodized
- Anodized + ESPC 60-130 microns
- Blackodised
- Epoxy coated 20-30 microns
- Zinc plated
- Only on sizes 084 and larger

Torque Output

Available in 11 models with either a spring return or double acting function. Table illustrates a portion of the torque range available.

For full torque and dimensional data, please refer to the applicable data sheets on the [Bettis RPX-Series web site](#).

Actuator size	Double Acting		Spring Set	Spring Return				Spring Return			
	Metric (@ 5.5 barg) Nm	Imperial (@ 80 psi) lbf.in		Spring stroke (Nm)		Air Stroke (Nm) @ 5.5 barg		Spring stroke (lbf.in)		Air Stroke (lbf.in) @ 80 psig	
				Start	End	Start	End	Start	End	Start	End
RPX 003	31	275	10	22	15	16	8	196	128	142	74
RPX 004	46	408	10	32	21	25	14	287	189	221	123
RPX 006	66	586	10	60	31	36	7	530	273	317	65
RPX 009	106	941	10	73	49	57	33	646	429	511	295
RPX 014	166	1474	10	112	75	91	54	989	664	807	482
RPX 020	243	2157	10	175	117	126	68	1551	1032	1122	606
RPX 032	381	3383	10	279	186	195	102	2466	1644	1739	917
RPX 052	577	5123	10	449	299	278	128	3974	2650	2475	1151
RPX 084/085	963	8549	10	736	491	473	227	6515	4343	4209	2037
RPX 140/141	1674	14862	10	1227	818	856	447	10856	7238	7626	4007
RPX 240	2765	24547	10	2079	1386	1379	686	18397	12265	12284	6148

Product Configuration Code

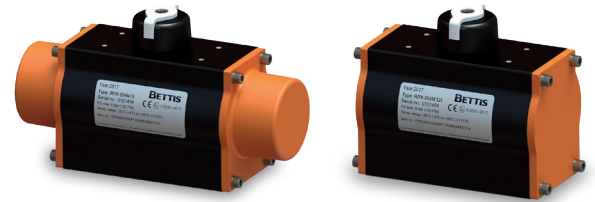
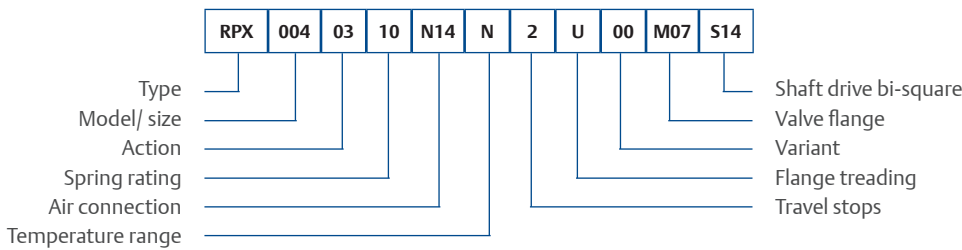

Type					
RPX	Bettis RPX-Series rack and pinion actuators				
Model / Size					
Code	Size	Code	Size	Code	Size
003	003	014	014	084	084
004	004	020	020	085	085
006	006	032	032	140	140
009	009	052	052	141	141
				240	240
Action					
01	DA				
03	SR FC CW [std]				
04	SR FC CCW				
Spring Rating					
04	4 springs	08	8 springs	12	12 springs
05	5 springs	09	9 springs	XX	not applicable
06	6 springs	10	10 springs		
07	7 springs	11	11 springs		
Air Connection					
N14	1/4" NPT	P14	1/4" BSPP		
N12	1/2" NPT	P12	1/2" BSPP		

Temperature Range	
H	High temp. -15°/+150°C +5°/+302°F (FKM)
N	Standard temp. -20°/+80°C -4°/+176°F (NBR)
L	Low temp. -40°/+65°C -40°/+149°F (L-NBR)
Travel Stops	
2	Dual shaft (std)
3	End cap (single)
4	End cap (double)
Flange Threading	
M	Metric
U	Imperial
Variant	
00	Standard visual indicator knob
A4	Visual indicator and A4 SST bolts
N0	No indicator
N4	A4 SST bolts, no indicator

Valve Flange			
Actuator Size	Code	ISO Drilling Patterns	
003	M07	= F05 + F07	
004	M07	= F05 + F07	
006	M07	= F05 + F07	
009	M07	= F05 + F07	
014	F07	= F07	
020	M11	= F07 + F10 + F12	
032	M12	= F10 + F12	
052	M12	= F10 + F12	
084	F14	= F14	
085	M16	= F12 + F16	
140	F14	= F14	
141	M16	= F12 + F16	
240	M25	= F16 + F25	
Shaft drive bi-square			
Actuator Size	Code	mm	Inch
003	S14	14	0.551
004	S14	14	0.551
006	S17	17	0.669
009	S17	17	0.669
014	S17	17	0.669
020	S22	22	0.866
032	S27	27	1.063
052	S27	27	1.063
084	S36	36	1.417
085	S36	36	1.417
140	S46	46	1.811
141	S46	46	1.811
240	S46	46	1.811

This product is only intended for use in large-scale fixed installations excluded from the scope of Directive 2011/65/EU on the restriction of the use of certain hazardous substances in electrical and electronic equipment (RoHS 2).

Precision quarter-turn action provides accurate 90 degree movement ensuring complete open and closed positioning for rotary valves



BETTIS™

NORTH & SOUTH AMERICA

19200 Northwest Freeway
Houston TX 77065
USA
T +1 281 477 4100

Av. Hollingsworth
325 Iporanga Sorocaba
SP 18087-105
Brazil
T +55 15 3413 8888

ASIA PACIFIC

No. 9 Gul Road
#01-02 Singapore 629361
T +65 6777 8211

No. 1 Lai Yuan Road
Wuqing Development Area
Tianjin 301700
P. R. China
T +86 22 8212 3300

MIDDLE EAST & AFRICA

P. O. Box 17033
Jebel Ali Free Zone
Dubai
T +971 4 811 8100

P. O. Box 10305
Jubail 31961
Saudi Arabia
T +966 3 340 8650

EUROPE

Holland Faszor 6
Székesfehérvár 8000
Hungary
T +36 22 53 09 50

Strada Biffi 165
29017 Fiorenzuola d'Arda (PC)
Italy
T +39 0523 944 411

 go.emersonprocess.com/bettisrpx

 [emrsn.co/facebook](https://www.facebook.com/emrsn.co)

 [emrsn.co/linkedin](https://www.linkedin.com/company/emrsn.co)

 [emrsn.co/twitter](https://twitter.com/emrsn.co)

The Emerson logo is a trademark and service mark of Emerson Electric Co. © 2019 Emerson Electric Co. Bettis logotype is registered trademarks of one of the Emerson family of companies. All other marks are the property of their respective owners. © 2019 Emerson. All rights reserved.
BRO-02-02-0040-EN Rev C 11-19



CONSIDER IT SOLVED.™