

AVENTICS 

**OUR APPLICATION
EXPERTISE**
PNEUMATICS IN
HYGIENIC DESIGN

Pneumatics
It's that easy





AVENTICS 7742
Ø 32 SL: 40 FD: 10w04
pmax: 10 bar TYP: ICS
ICS-D1-032-0040-0-00MP4106A1W04NF000000
MNR: R480178677
Made in Sweden

1 - F - PUR - 6x1.05 - max. Driftleistung

“Best-in-class” components and proven pneumatic solutions for optimal automation

Handling food requires the greatest care. Requirements on hygienic work processes are particularly high, and extensively regulated by laws, directives, and standards. All activities have a single goal: food safety.

As a specialist for automation solutions in your industry, we know what really counts

The automation of work processes in the food and beverage industry is a very demanding task which requires a high level of attention to numerous factors – for machine and component design, as well as during the ongoing production process. Our specialists offer in-depth industry expertise and assist you in implementing your tasks efficiently taking into account all relevant specifications.

- Ensuring food safety
- Hazard analysis and HACCP plan
- Hygiene standards and adjusted electrical protection class
- Ensuring compressed air quality
- Food-safe lubricants
- Chemical resistance

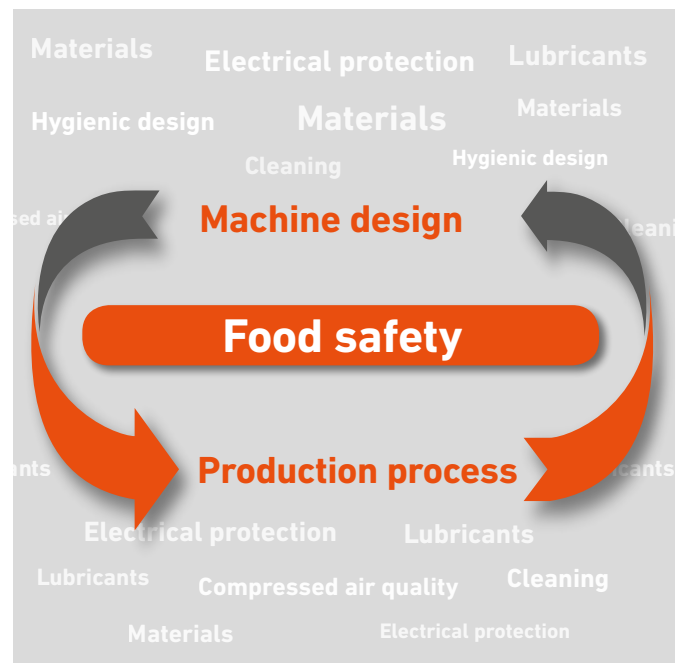



Comply with hygiene standards is an absolute must, particularly in wash-down applications

Wherever components can come into direct contact with food, frequent wash-down is required to comply with hygiene standards. Our components and actuators have been designed with these extreme operating conditions in mind. This is why they can be placed close to or directly in the production process.

The wide variety of versions and sizes provides the basis for fully flexible dimensioning of machines and systems, based on operating conditions and exact needs.

- Most extensive range of products in stainless steel
- Market leader in the use of high-tech plastics
- Comprehensive spectrum of variants for needs-based configuration

Production process from process technology to packaging

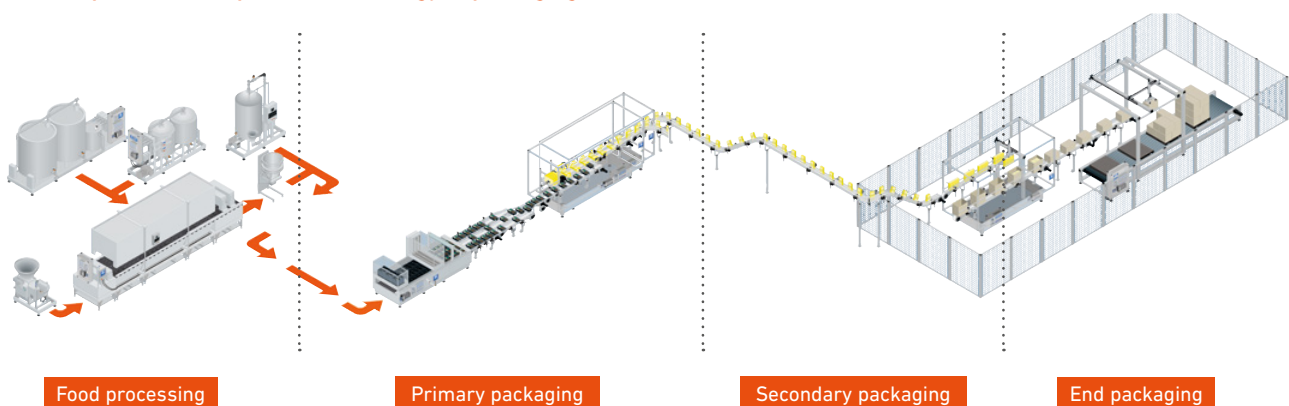

For those who don't want to compromise

Product quality, cost-effectiveness, hygiene. Food and beverage manufacturers have to offer high-quality products at competitive prices. The high level of competition in the food and beverage industry requires increasingly cost-effective work processes. Of course, food safety is paramount. Our pneumatics solutions will help you along the way.

Process technology and primary packaging

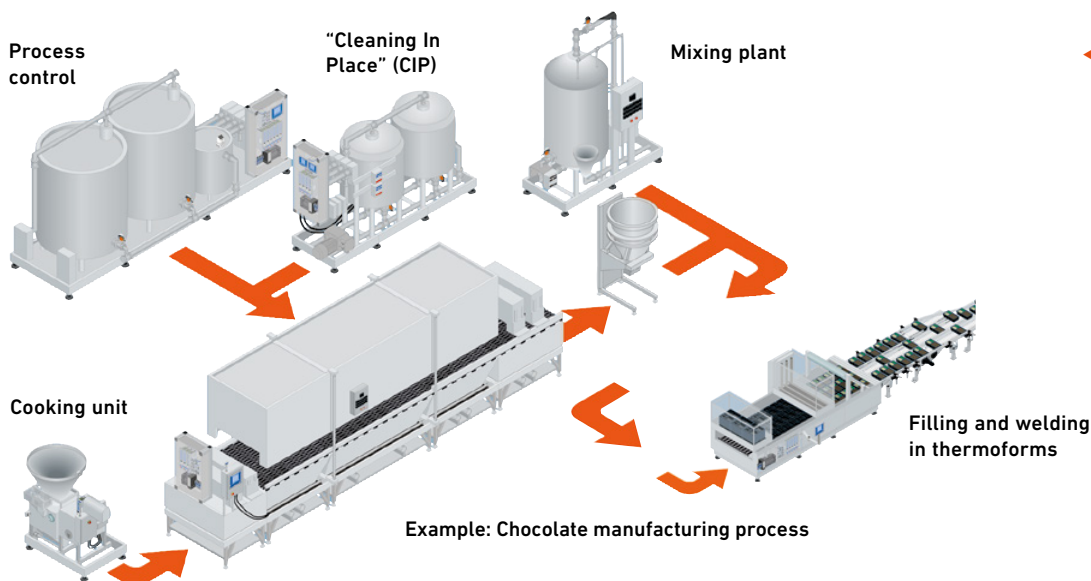

◀ Easy cleaning, chemical resistance, and the high component protection classes are all important parameters for the food production and primary packaging industries.

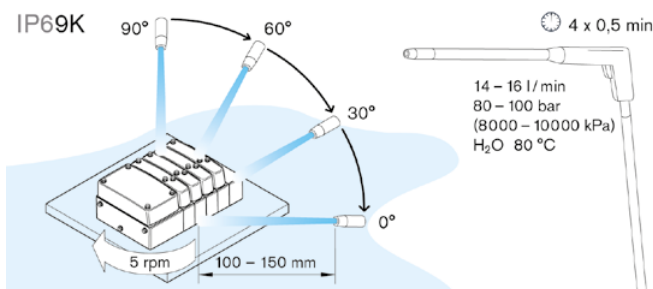

Designation	Meaning
IP65	Protected against low-pressure jets of water from all directions
IP66	Protected against strong jets of water
IP67	Protected against the effects of immersion in water at a depth of 1 m
IP68	Protected against the effects of continuous immersion in water at a depth exceeding 1 m
IP69K	Protected against high-pressure water and steam jet cleaning

Complete pneumatic automation for the food and beverage industry – from compressed air preparation to the actuator

Developed for you: Our wide range of products has been tailored specifically to the requirements of the food and beverage industry and offers all the options you need for individual configurations – with matching components and comprehensive solutions that are both safe and efficient.

Hygienic design

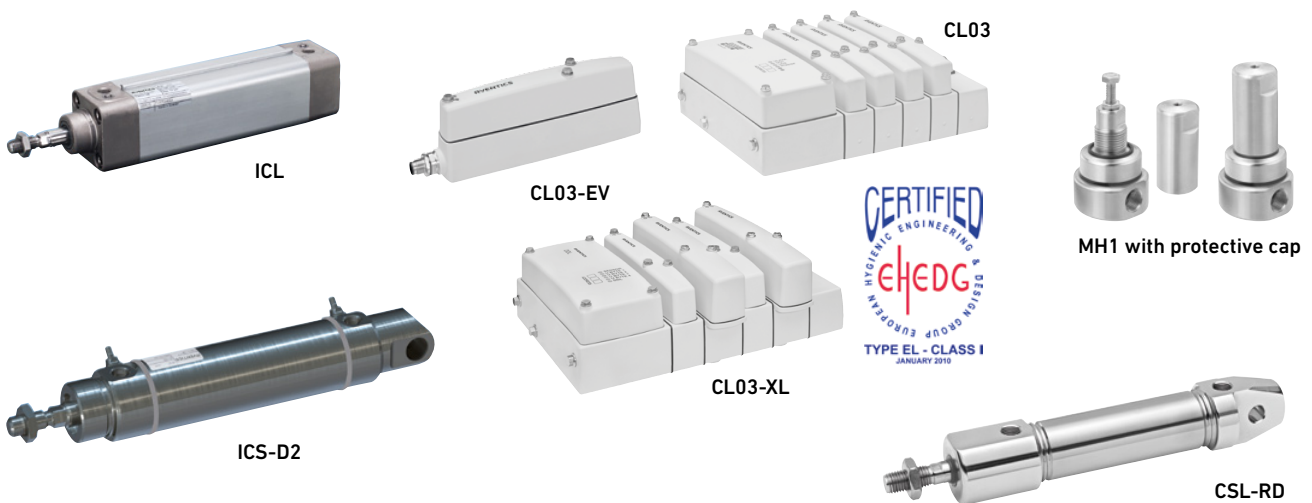

ICL series cylinders

Cylinder series ICL, Clean Line for easy cleaning. NSF H1 lubrication.

ICS-D2 series cylinders

Stainless steel cylinders from series ICS-D2 meet the highest requirements for hygienic design and chemical resistance. Seals designed specifically for the food industry. NSF H1 lubrication.

CL03 series valve system

Valve system series CL03 with bus module and excellent protection class IP69K. NSF H1 lubrication. EHEDG-certified with bus connection. CL03 series available in two sizes also with multipole plug and as a CL03-EV series single valve.

MH1 series pressure regulators

Pressure regulator series MH1 in a stainless steel version, optionally with protective cover in hygienic design. Materials comply with standards NACE MR0175 and ISO 15156.

Application optimized - impeccable hygiene



Advantages

- ✓ Food safety guaranteed
- ✓ Hygiene standards fulfilled
- ✓ Increased energy efficiency
- ✓ Cleaning procedures simplified
- ✓ Reduced downtimes

Components for process technology and primary packaging

Products with a **hygienic design** meet all essential requirements for hygienic engineering and material selection.

Products in a **stainless steel version** also provide the required corrosion resistances, in addition to being resistant to cleaning agents and disinfectants.

Products for **specific applications** offer special solutions for handling foodstuffs, as well as a range of accessories suitable for food products.

Stainless steel version

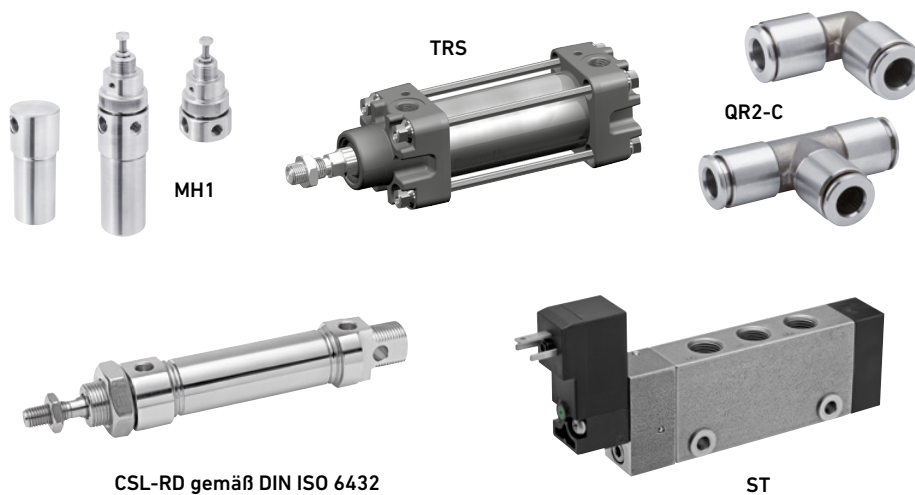

Specific products

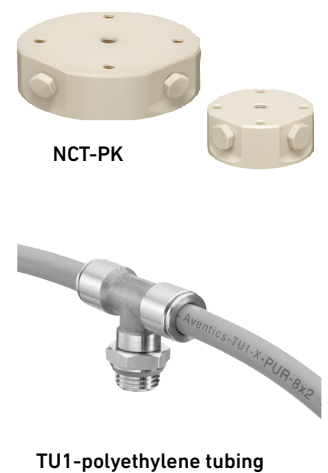

CSL-RD series cylinder

Round cylinder series CSL-RD Stainless Line, optionally in hygienic design or in accordance with DIN ISO 6432. NSF H1 lubrication.

TRS series cylinders

Stainless steel, acid-proof tie rod cylinders available with diameters of 32 – 160 mm.

ST series valves

Highly resistant single valve with stainless steel housing, available as 3/2 and 5/2-way valves, actuated electrically, pneumatically, or mechanically.

QR2-C series plug-in connectors

QR2 fitting series, stainless steel.

Specific products

Non-contact gripping with series NCT-PK, made of PEEK (FDA-approved), suitable for direct contact with food products. PE tubing ensures high resistance to chemicals.

More information:



Ensure your technological lead – using only the best for your application

Innovative product concepts based on user experiences from daily practice

Hygienic design, high-quality materials, special surface properties – AVENTICS components and solutions are designed to be better than the market standard – more advanced, more efficient, and flexible. Take the new CL03 series single valve, for example, which opens up many new applications, or the CSL-RD series cylinder with innovative features.

- Industry-specific product development, "best-in-class" components
- Application-based component configuration and dimensioning
- Application-specific product customization

These are the services we provide – in dialog with you, incorporating your experiences and suggestions. In addition, our online portal is available for you around the clock.

- All products and technical details in the online catalog
- Calculation tools
- Product configurators for a complete unit, including accessories and comprehensive technical documentation
- D&C Scheme Editor for creating complete circuit diagrams with bills of material

CL03-EV series

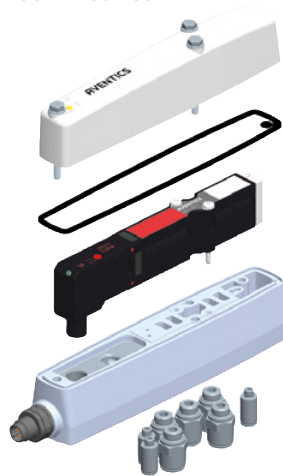

- ▶ The CL03 series valve provides all valve functions, has the highest protection class (IP69K), and is currently the only hygienically designed single valve on the market.
 - PA12 base plate and cover, M12 connection (V4A)
 - Pneumatic connections on the bottom, electrical connection on the front
 - Protection classes: IP69K, IP67, and IP65

CSL-RD series

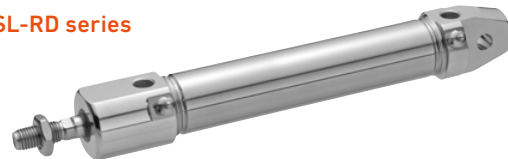

- ▶ The CSL-RD has a smooth profile, has low surface roughness, and works with a food grade lubricants and sealings.
 - Innovative roll-up process without detectable gaps on the covers
 - Wide range of variants: hygienic design, ISO version, short version

- ▶ The free-of-charge programs allow you to configure components online, bringing you a step closer to your optimal solution.

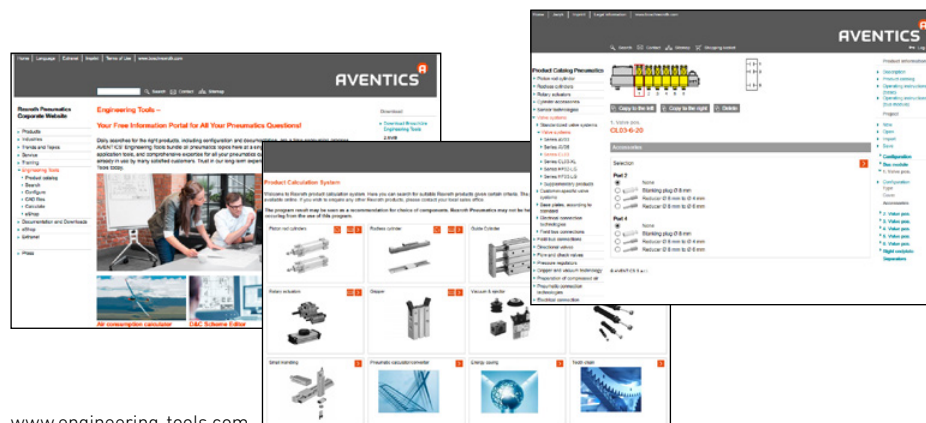

AVENTICS

www.aventics.com
info@aventics.com

Follow us:



www.aventics.com/hygienic-design



Germany

AVENTICS GmbH
Ulmer Straße 4
30880 Laatzen, Germany
Tel +49 511 2136-522
Fax +49 511 2136-163
www.aventics.de

USA

AVENTICS Corporation
PO Box 13597
1953 Mercer Road (40511)
Lexington, KY 40512
Tel +1 859 254-8031
www.aventics.us

China

AVENTICS Group
2002 Unit, Asdendas Plaza, No 333
Tianyaoqiao Road, Xuhui district
Shanghai, China, 200030
Tel +86 21 2426 9666
www.aventics.cn

Further contacts

www.aventics.com/contact

Your contact:

The data specified above only serve to describe the product. No statements concerning a certain condition or suitability for a certain application can be derived from our information. The information given does not release the user from the obligation of own judgment and verification. It must be remembered that our products are subject to a natural process of wear and aging.