



High-Precision Gas Purity Analysis: Techniques and Technologies

Process Gas Analytical Solutions
For gas purity



Gas Purity Solutions

Visualize *the ability to analyze impurities and measure purities across your entire process.*

Analyze *the entire scope of process measurements using analyzers from one company – Emerson.*

Optimize *your analytical process by combining multiple measurements in a single analyzer to reduce the complexity of the system.*

To purify process gas, high-quality analytical data is required for monitoring trace components, reducing undesired accumulations, eliminating equipment plugging, avoiding catalyst poisoning, and ensuring overall asset integrity.

Rosemount uses a strategic approach to enable the production of high-purity gases for the refinery, petrochemical, chemical, and gas processing industries; in bottling processes for food & beverage, medical, and welding/shielding gases; and in air separation plants.



Visualize

Analysis and Measurement for High-Purity Gases

Whether your application requires medical-grade gas or a specialty gas mixture unique to your particular instrument or industry, Emerson's Rosemount Analytical process gas analyzers offer analysis and measurement of chemical gas down to a low ppm range.

With an analytical solution from Emerson, you can expect:

- ✓ Improved production efficiency
- ✓ Improved safety conditions
- ✓ Improved asset availability
- ✓ Reduced maintenance and spare parts costs

In addition, we ensure full compliance with international legislation and country-specific regulations governing gas purity within food production and medical gas bottling, including those governed by the US FDA, European and US pharmacopoeia, EIGA, and the Compressed Gas Association.

Gas Purity Solutions for Your Process

> Gas Processing

- Syn Gas:
 - Steam reforming of natural gas
 - Coal and wood gasification
 - Biomass or waste gasification
- Gas cleaning:
 - Pressure swing absorption (PSA)
 - Amine washers

> Gas Bottling

- Food and Beverage
- Medical
- Welding / Shielding

> Air Separation

Precise analysis across your entire range.

Gas Purity Applications

Visualize

Gas Processing in Refinery Petrochemical and Chemical Industries

A wide range of refinery, petrochemical and chemical processes require a certain level of purity in their feed gas streams for ethylene, ammonia, and methanol production. Syngas is produced from steam reforming of natural gas, coal, and wood, as well as biomass/waste gasification,

and can be used for production of pure hydrogen (H₂) or carbon monoxide (CO). Syngas is also an important building block for processes like Fischer-Tropsch. Feed gases contain impurities that can affect the process chain and integrity of the end product.



Your Process Requirements	Your Process Goals	Our Analytical Measurement Capabilities
Monitor trace carbon monoxide in hydrogen	Avoid catalyst poisoning and improve catalyst durability	X-STREAM CO: 0-10 / 100 ppm
Analyze trace oxygen impurities	Maintain an inert atmosphere to prevent oxidation processes or explosive conditions	X-STREAM Trace O ₂ : 0-10 / 100 / 1,000 ppm O ₂ : 0-1%
Measure carbon dioxide within process streams	Reduce problems caused by hydrocarbon interference or build up of carbamates / carbonates plugging the tubes or vessels	X-STREAM CO ₂ : 0-5 / 10 / 100 / 1,000 ppm
Monitor carbon monoxide at a phosgene production plant	Ensure phosgene purity with the gas stream, and at ppm levels in the stacks	X-STREAM CO: 0-15%



Gas Bottling Solutions

High-purity gases are used throughout the food and beverage industry, medical field, and welding/shielding gas processes. Controlling the purity of carbon dioxide, nitrous oxide, and oxygen through

the bottling process and maintaining specific gas mixtures helps to slow product degradation, manage the ripening process, eliminate infestations, and ensure the quality of the final product.

Your Process Requirements	Your Process Goals	Our Analytical Solutions
<p>Food & Beverage Industry gases are used as:</p> <ul style="list-style-type: none"> • food additives • food processing aids • food ingredients <p>Different regulations have to be fulfilled to ensure consumer safety.</p>	<p>Purity/Impurity measurement</p> <ul style="list-style-type: none"> • CO₂ carbonation of beverages • liquid N₂ or CO₂ for preservation • SO₂ wine and dried fruit preservation • N₂O stops the growth of bacteria and acts as foaming agent <p>Controlled mix of gases</p> <ul style="list-style-type: none"> • N₂ and C₂H₄ in ripening • Controlled Atmosphere Storage (CAS) • Modified Atmosphere Packaging (MAP) 	<p>X-STREAM O₂: 80 / 90 / 95 / 98–100% and 20–22% CO₂: 90 / 95 / 98–100% N₂O: 90 / 95 / 98–100% CO: 0–5 / 10 / 100 / 1,000 ppm SO₂: 0–25 / 50 ppm C₂H₄: 0–400 ppm</p> <p>Trace O₂: 0–10 / 100 / 1000 ppm</p> <p>CLD NOx: 0–5 / 10 / 100 ppm</p>
<p>Medical The European and US Pharmacopoeia set minimum requirements on quality</p>	<p>Monitor product qualities to fulfill medical regulations</p> <p>O₂: > 99.5% or 20.4% < O₂ < 21.4% CO₂: > 99.5% N₂O: > 98.0 or 99.0% CO: < 5 ppm CO₂: < 300 ppm or < 500 ppm H₂O: < 67 ppm O₂: < 50 ppm or < 5 ppm NOx: < 2 ppm</p>	<p>X-STREAM O₂: 98–100% and 20–22% CO₂: 98–100% N₂O: 98–100% CO: 0–10 / 20 ppm Trace CO₂: 0–1,000 ppm</p> <p>H₂O: 0–100 / 300 / 3000 ppm Trace O₂: 0–10 / 100 ppm</p> <p>CLD NOx: 0–5 / 10 ppm</p>
<p>Welding / Shielding Measure carbon dioxide, oxygen, helium and hydrogen in argon as components</p>	<p>Provide high quality shielding gases to improve weld characteristics</p>	<p>X-STREAM CO₂: 0–5 / 10 / 60% O₂: 0–2 / 10% He: 0–20 / 100% H₂: 0–2 / 5 / 20%</p>

Gas Purity Applications

Analyze

Air Separation Solutions

Cryogenic air separation processes ensure a reliable gas and liquid supply, which are critical for process applications such as steel production. Using a process of compressing and cooling atmospheric air, these plants separate nitrogen, oxygen, argon, and other inert gases from contaminants such as moisture, carbon dioxide, and hydrocarbons. Trace and purity measurements are required throughout the

removal process to ensure quality control. Emerson delivers the complete product range to optimize the air separation process and monitor product quality without the need to combine analytical equipment from multiple suppliers.

Your Process Requirements	Your Process Goals	Our Analytical Solutions
Ensure that all gaseous hydrocarbons have been removed	Reduce the likelihood of problems in the air distillation process	X-STREAM O ₂ : 80–100% and 0–20%
Ensure that all moisture has been removed from the process air	Avoid freezing in the cryogenic equipment Ensure quality of all product streams	X-STREAM Dew point: -100 °C to -10 °C H ₂ O: 0–100 / 300 / 3,000 ppm
Ensure that all carbon dioxide has been removed from the process air	Avoid freezing in the cryogenic equipment Ensure quality of all product streams	X-STREAM CO ₂ : 0–5 / 10 / 100 / 1,000 ppm
Measure percent oxygen: - after HC removal - before and after crude argon column - in the oxygen product stream	Ensure efficient operation of the low-pressure column and crude argon column Ensure quality of oxygen product stream	X-STREAM O ₂ : 0–50% O ₂ : 80–100% and 0–20% O ₂ : 98–100%
Measure trace oxygen in argon and nitrogen product streams	Control the product purity	X-STREAM O ₂ : 0–10 / 100 / 1,000 ppm
Measure argon in crude argon column feed and product	Control crude argon column and quality of Ar product	X-STREAM Ar: 0–50% Ar: 85–100%
Measure hydrogen behind oxygen removal unit	Minimize the excess hydrogen that is introduced to the crude argon column product	X-STREAM H ₂ : 0–3%

Figure 1 - Gas Purity Solutions

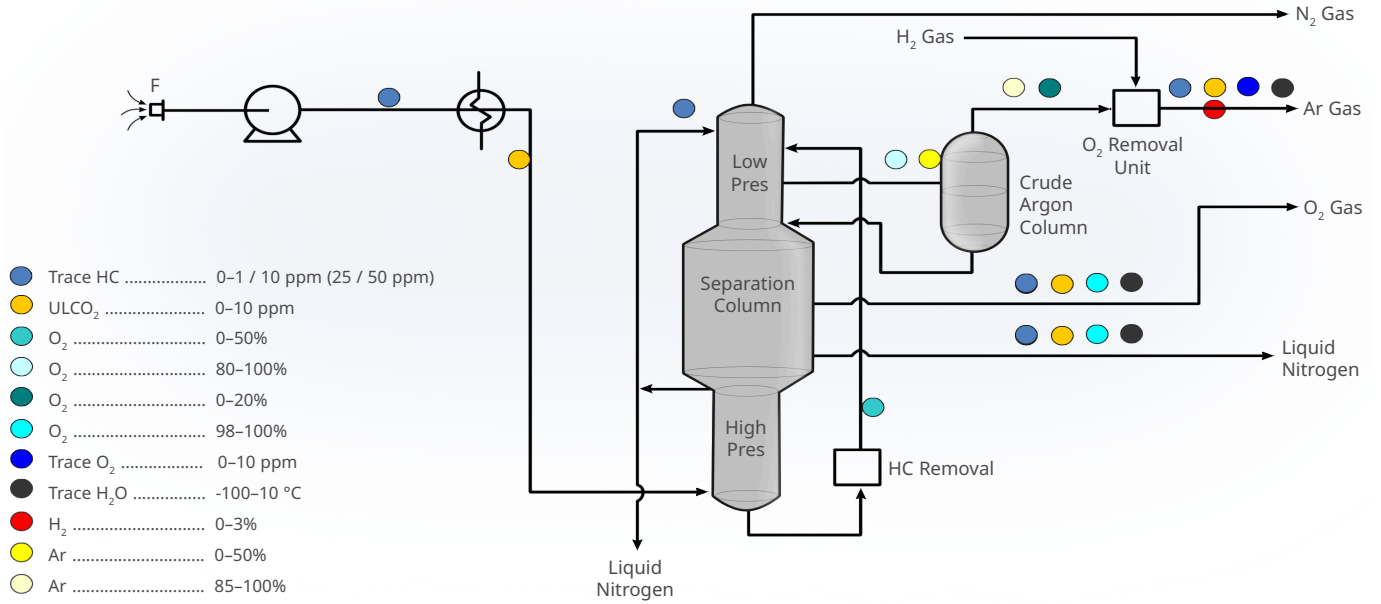

Gas Purity Applications

Analyze

You can expect exceptional operational reliability and high on-spec yields with analytical equipment from Emerson.

X-STREAM Process Gas Analyzers

The X-STREAM process gas analyzer is perfect for multi-component analysis. It uses non-dispersive infrared, ultraviolet, and visible photometry (NDIR/UV/VIS), paramagnetic and electrochemical oxygen (pO_2/eO_2), and thermal conductivity (TCD) sensor technologies, as well as trace oxygen (trace O_2) and trace moisture (trace H_2O) for consistent, precise process gas measurement.

X-STREAM measures up to five components in various combinations and its versatile design allows physical benches to be installed in their own compartment, separate from the electronics.

X-STREAM Enhanced Process Gas Analyzers

Rosemount sets new standards of ease of use with the X-STREAM *Enhanced* process gas analyzer. With a unique web-based interface that securely enables remote diagnostics without additional software installation and provides a host of convenient new features and user capabilities, the X-STREAM *Enhanced* simplifies the analytical experience. The X-STREAM *Enhanced* features the lowest total cost of ownership, lowest span drift, lowest temperature dependency, broadest total operating temperature range, and highest protection classes. The standard warranty is now 18 months from ship date / 12 months from installation.



X-STREAM XECLD Analyzer Enable Ultra-low NOx Measurements

The X-STREAM *Enhanced* XECLD continuous gas analyzer is purpose-built to detect ultra-low concentrations of NOx emissions in industrial and commercial operations.

It uses highly stable Chemiluminescence Detection (CLD) for compliance with environmental regulations, including U.S. EPA Method 7E and EN 14792-2017.



Gas Purity Applications

Optimize

Analytical Solutions for the Upper and Lower Ends of the Concentration Scale

Cryogenic air separation processes ensure a reliable gas and liquid supply, which are critical for process applications such as steel production. Using a process of compressing and cooling atmospheric air, these plants separate nitrogen, oxygen, argon, and other inert gases from contaminants such as moisture, carbon dioxide, and hydrocarbons. Trace and purity measurements are required throughout the removal process to ensure quality control.



Measurement	Lowest range	Our Analytical Measurement Capabilities
Trace O ₂	0–10 ppm	Trace oxygen fuel cell measurements in various backgrounds, including acid components such as carbon dioxide (CO ₂). It can be combined with other measurement technologies in one analyzer.
Trace H ₂ O	-100 °C to -10 °C dew point 0–100 / 300 / 3,000 ppm	Aluminum-oxide-based sensor technology for low maintenance measurement of trace moisture concentrations with an accuracy of ±2 °C dew point.
UltraLow CO	0–10 ppm	NDIR photometer measurements with a detection limit (4σ) of 0.2 ppm combined with robustness against vibration for uncompromising performance even in toughest environments.
UltraLow CO ₂	0–5 ppm	NDIR photometer measurements with a detection limit (4σ) of 0.1 ppm combined with robustness against vibration for uncompromising performance even in toughest environments.
Low H ₂ Low N ₂	0–1,000 ppm	Thermal conductivity measurement of impurities in hydrogen or impurities of hydrogen. A constant flow is essential for low TCD measurements and provided internally for both (sample and reference) sides working in flow-reference mode.
Suppressed ranges CO ₂ , N ₂ O, O ₂ , H ₂	98–100% additionally 20–22% O ₂	Using NDIR photometer technology, paramagnetic and thermal conductivity detectors purity measurements in suppressed ranges up to 98–100%. Best-in-class linearities enable us to use 100% gases for calibration, avoiding additional errors from test gas mixtures (H ₂ is an exception).
CLD for NO _x	0–5 ppm	With a chemiluminescence detector, the lowest NO _x range of 0–5 ppm in combination with a selective converter and very low quenching is available.

Analytical Lifecycle Systems and Services

Systems Engineering and Project Management

The Rosemount™ global systems experts manage and implement full-scale analytical systems projects of all sizes and scope. We use detailed processes to ensure that systems are delivered on time and on budget.

Our project management process includes:

- Project Identification & Scope
- Initial Engineering & Design
- Implementation & Testing
- Commissioning & Startup
- Training
- Maintenance
- Lifecycle Services Contracts



Lifecycle Services and Support

Our team of trained and certified field experts know and understand the requirements needed to develop a customized service program to suit your application. We provide complete turn-key services and problem solving to assist you every step of the way. From pre-installation services to on-going maintenance and support long after commissioning, we have the expertise to ensure your Rosemount™ system runs at ideal operating conditions during its lifecycle.

Field services include, but are not limited to the following:

- Startup and commissioning
- Scheduled maintenance
- On-site support
- Field retrofits
- Training



High Precision Gas Purity Analysis: Product Solutions and Applications for Measurement



The Emerson logo is a trademark and service mark of Emerson Electric Co.
Rosemount is a registered trademark of one of the Emerson family of companies.
All other marks are the property of their respective owners.
© 2024 Emerson Electric Co. All rights reserved.

00803-0100-3701 Rev AA

