

Optimize production, improve reliability and reduce operating costs.



ASCO™ Series 290/390 Angle Seat Valves
Achieve unparalleled flow or pressure control of liquids, steam and gases.



You are challenged to optimize production and reduce operating costs, whilst maintaining the highest levels of reliability.

You are tasked with reducing operating costs year on year through efficiency improvements and increased process availability, but unplanned downtimes, often caused by valve failure and leakages, are hampering production and sustainability efforts. Minimizing unplanned downtime and maintaining overall production efficiency must remain your priority. Time is precious, especially when implementing new processes or developing new machines. This requires you to quickly identify valves that fulfill the specification, environment and certification requirements.

Unscheduled downtime is responsible for significant costs in global process industries. For example, an estimated \$20bn, or 5% of annual production, is lost as a result of this downtime every year.
– ARC Advisory Group



“Valves account for more than 51 percent of fugitive emissions, and greenhouse gases are part of this.”
– Gobind Khiani, Fluor Canada



“Time delays in launching new machines cause much greater reduction in profitability than cost overruns, so there is increasing emphasis on reducing development times.”
– Managing innovation and entrepreneurship in technology-based firms – Michael J. C. Martin





Instead of losing productivity due to unplanned shutdowns or slowdowns caused by valves, what if you could minimize process failures and reduce maintenance frequency?

The ASCO Series 290 optimizes production performance and improves your overall process reliability.



The ASCO Series 290 angle seat valves are designed to simplify your fluid control project challenges, improve plant and worker safety and lower operating costs. Setting new standards in performance and reliability, this flexible modular solution meets the requirements of a diverse range of media with a single valve reference, simplifying engineering, installation and commissioning. Proven reliability, a long service life in high cycle frequency applications and smart diagnostic functionality supporting preventative maintenance strategies, helps to increase process availability and lower your plant operating costs. The safety of installations, workers and the impact on the environment are reinforced by a rigorous design and unique know-how.

ASCO[™]



“Our fermenter thermo-regulation system has been improved by the extremely precise and reliable closed-loop temperature control provided by ASCO Series 290 valves.”
– Integrator and manufacturer of process vessels

Don't let valve reliability reduce productivity and increase operating costs.

A high throughput machine for form, fill and sealing required a valve that could provide high cycles and improved reliability over its lifetime. The ASCO Series 290 was selected and helped to create a machine that increased productivity and reduced overall maintenance costs.

– Packaging equipment supplier, Italy

Reliability ► p6

Ensure that valves do not affect your project timescales.

For a life science sterilizer system a valve was needed that could handle a variety of media, such as water, steam, and vacuum. The ASCO Series 290 valves were selected because a single valve design was capable to handle all of the medias without requiring specific options which would have delayed the project.

– Autoclaves manufacturer, USA.

Commissioning ► p10

Increase plant and worker safety and reduce environmental impact.

The ASCO Series 290 valves have an anti-water hammer design, which protects both pipework and instrumentation from potential damage, they have numerous certifications that protect our environment, their design protects workers during their use or during maintenance.

– Global product manager for ASCO products, Emerson

Safety ► p8

Optimize production with greater valve diagnostics and data accessibility.

As producers look towards data-driven decision making, and remote monitoring with improved visualization, ASCO is staying ahead by offering a comprehensive range of signal boxes with improved diagnostics and industry leading protocols such as IO link.

Production ► p12



Reduce your total OPERATING COSTS

You are under continued pressure to reduce operating costs by increasing operating efficiencies and equipment and process availability. High performance ASCO Series 290 valves provide reliable and precise control, helping to optimize production and maximize the efficiency of processes. Lower compressed air consumption helps to reduce energy costs. A long operating life extends the intervals between maintenance, while the rugged design meets the demands of challenging operating environments and aggressive media. Diagnostics supporting preventative maintenance help minimize unexpected downtime that reduces productivity and increases maintenance costs.

What's your challenge?



Unscheduled downtime is responsible for significant costs in global process industries. For example, an estimated \$20bn, or 5% of annual production, is lost as a result of this downtime every year.

– ARC Advisory Group



What's your opportunity?

The greater flow capacity provided by the ASCO Series 290 on/off valves helped to reduce operating costs by increasing the efficiency of new on-site pressure swing adsorption N2 and O2 generators. High performance valves combined with Emerson's outstanding customer service helped to create the fluid control solution.

– European oxygen/nitrogen generator manufacturer

Lower energy costs



Reduced compressed air requirements due to very low actuator volume that requires 3 to 4 times less pilot air volume than a ball valve.

Increase production efficiency



Proportional control enables precise and accurate control within a closed loop system, increasing and optimizing process performance contributing towards lower operating costs.



Highest Kv/flow rate in its class, helping to improve production efficiency of the customer process.



Large pilot orifice size enables very fast opening and closing, helping to increase the performance and productivity of machines and processes.

Lower maintenance costs



Long lifecycle in applications with high number of cycles extends the time between replacement helping to increase equipment and process availability.

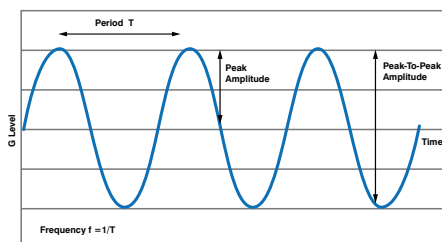

Rugged design and high quality construction provides strength, resiliency and reliability in demanding applications such as those with high levels of vibration extending service life and reducing replacement costs.



Actuator requires almost no maintenance over the lifetime of the valve, helping to reduce costs.



Find out more about the ASCO Series 290 at Emerson.com/ASCO



Enhance the SAFETY of plant and workers

Health and safety of plant and workers is the number one priority, which requires you to assess the impact of implementing different automation technologies. Valves play a crucial role in worker and plant safety. The ASCO Series 290 valves have been developed with safety in mind, with a design that enables safe dismantling during maintenance procedures. An anti-water hammer design helps to prevent damage to pipework that could cause dangerous leaks impacting instrumentation critical for maintaining process control and safety. The series 290 is designed to minimize fugitive emissions, further reducing the risk to workers and environmental impact.

What's your challenge?

51%

"Besides the environmental impact, fugitive emissions are also considered as the main source of background exposure of workers to harmful chemical substances in chemical plants. Continuous, daily exposure to such emissions may pose a serious threat to the health of the workers."

– Alhamdani Y.A., Hassim M.H., Salim S.M.,
Occupational health risk assessment and control
of fugitive emissions



What's your opportunity?

Protecting maintenance staff must be a top priority and dismantling an actuator can be a dangerous procedure. The ASCO Series 290 actuator requires almost no maintenance and a safe actuator dismantling feature helps to minimize risk to workers.
– Global product manager for ASCO products,
Emerson

Protect equipment and environment

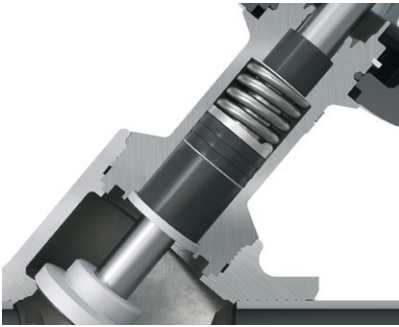

Heavy duty PTFE seal provides exceptional and repeatable tight shutoff and prevents the passage of dirt or external particles that causes wear. Designed to cope with aggressive fluids and high temperatures.



Anti-water hammer design For fast closing operations with liquids, the angle seat valve has an anti-water hammer design capable to absorb high peak pressures preventing damage to pipework and equipment.

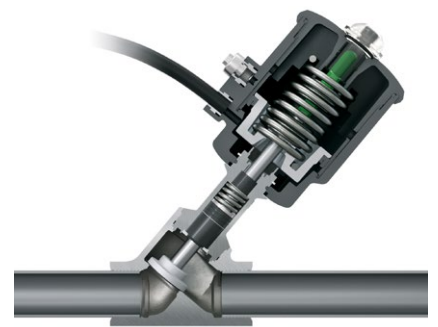

Body constructed with high grade corrosion-resistant materials including 316L stainless-steel that protects all parts of the valve over its lifetime from aggressive liquids/atmospheres.

Safety applications



ATEX and IECEX certifications for use in hazardous and explosive areas, SIL rated for safety instrumented systems and certified for use in machinery safety applications.



RoHS and REACH compliant materials meet the standards relating to the restriction of dangerous substances.

Safe operation and maintenance

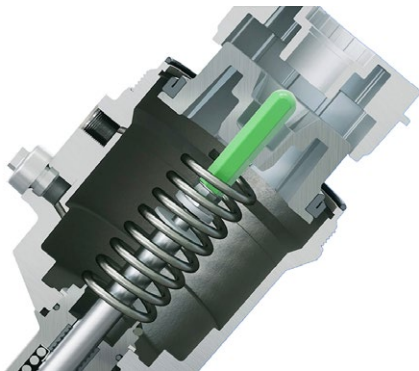

Safe actuator dismantling ensures that should the actuator need to be dismantled, maintenance workers are protected during this dangerous procedure.



Back pressure resistance increases process reliability and removes the need to add check valves, simplifying design and engineering tasks.



Find out more about the ASCO Series 290 at Emerson.com/ASCO



Increase project engineering and commissioning speed

As the complexity of projects increases, so does the time spent designing, engineering and installing fluid control solutions. Specifying valves can be arduous, but the ASCO Series 290 is designed for a broad range of media and application specifications, with a vast array of materials options, industry approvals and certifications. This outstanding versatility enables a single valve type to be deployed for different fluid lines, helping to reduce project engineering time. The flexibility provided by the modular design, comprehensive range of bodies and interchangeable actuator and control box, also helps to streamline installation and commissioning, simplify maintenance and reduce spare part management costs.

What's your challenge?



"Time delays in launching new machines cause much greater reduction in profitability than cost overruns, so there is increasing emphasis on reducing development times."

– Managing innovation and entrepreneurship in technology-based firms – Michael J. C. Martin



What's your opportunity?

The smaller footprint design of Emerson's ASCO Series 290 provided greater flexibility and enabled installation within the tight space constraints of the biscuit and cracker dough mixer.

– Major snack food manufacturer

Reduce design engineering time



Exceptional versatility enables a single valve to be selected for different media and applications, helping to minimize design and engineering time.



Compact actuators with smaller footprints help to reduce overall machine size.



QR code laser marking provides link to video tutorials and paperless product information, helping to speed up commissioning and maintenance.

Broad capability

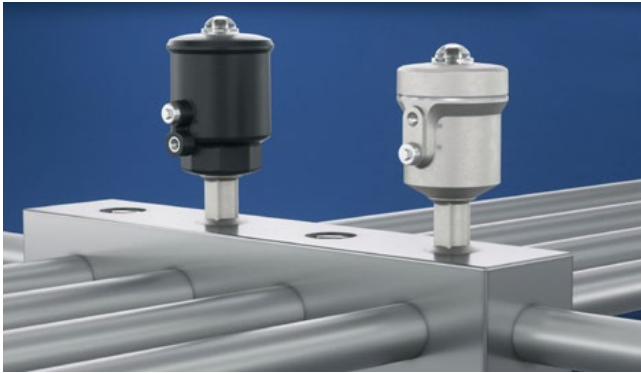

Manifold blocks makes it is easy to combine different functions, pressures and materials expanding the range of applications.

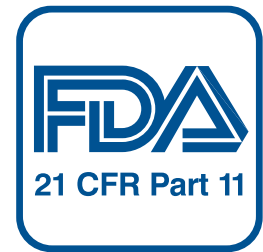

EC 1935/2004 and FDA CFR 21 certifications for use in food and beverage applications, helping to streamline industry approvals for skids and machines.

Reduce installation and commissioning time



Modular design with wide range of body connections, interchangeable actuators and switchbox provides efficient and easier assembly and commissioning. ▶ p14

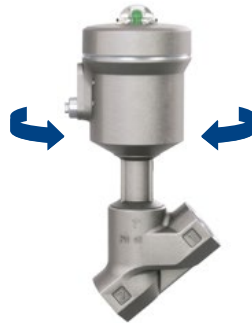

Pilot port 360 degree adjustable positioning to ensure easy access and help speed up commissioning.



Pre-tested at manufacturing site helping to prevent problems during start up.



Find out more about the ASCO Series 290 at [Emerson.com/ASCO](https://www.emerson.com/ASCO)

The ASCO Series 290: Enhanced fluid control performance for increased operational efficiency and safety

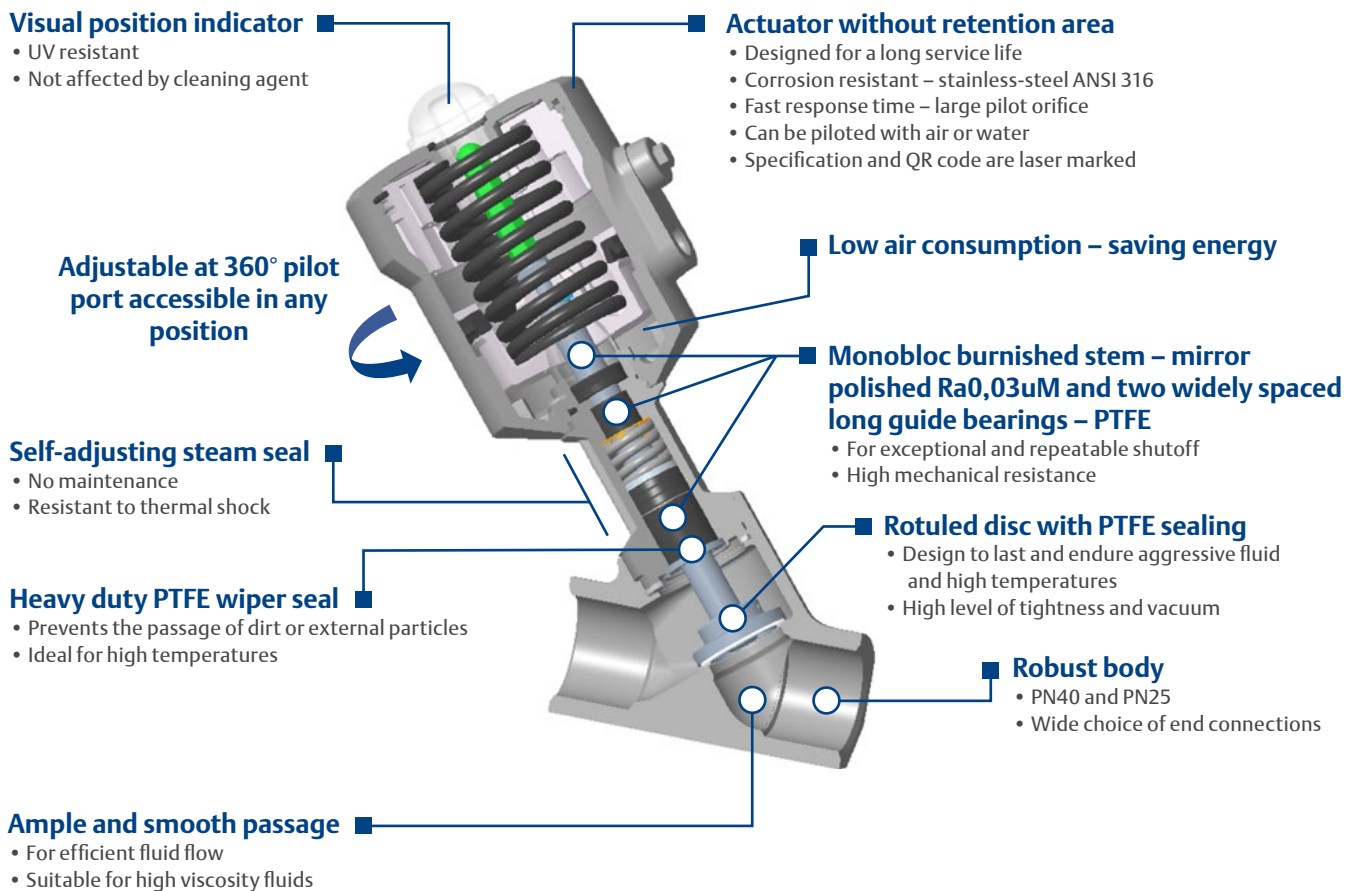

ASCO Series 290 overview

With hundreds of thousands of units installed and operating worldwide, Emerson’s ASCO Series 290 sets the standard for pressure-operated, direct acting angle-body piston valves. Providing up to five million cycles over its lifetime, these high-performance valves are designed to provide reliable fluid control performance in general service applications controlling air, inert gas, water, oil, light slurries, steam, hot water, vacuum, and all the auxiliary fluids required for the different industrial processes. At the heart of its design is an

extremely reliable fluid control mechanism that offers incredibly tight shut off, preventing leaks and fugitive emissions. The modularity of the ASCO Series 290 enables different actuators to be fitted to the same valve body. This provides exceptional flexibility and simplifies valve engineering by allowing a single valve reference to be deployed across different fluid lines. Outstanding durability, reliability and performance are complemented by digital connectivity and functionality for smarter operations. [Emerson.com/ASCO](https://www.emerson.com/ASCO)

Application flexibility and versatility



- Comprehensive range of bodies, actuators, options, control box and certifications



- Suitable for a wide range of media including aggressive fluids, steam, gas, vacuum and superheated water. Efficient flow design provides ample and smooth passage of fluids, including those with high viscosity

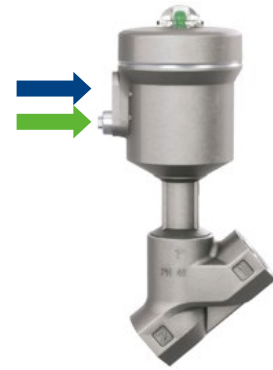

- Piloted by air or water with pilot pressure up to 10 bar, providing application flexibility and simplifying design and commissioning



- Robust PN16, PN25 and PN40 bodies available in bronze or stainless-steel resistant to aggressive and high temperature fluids, with a wide choice of end connections

- Broad range of pipe connection sizes, from DN10 to DN65 and suitable for pressures up to 25 bar ensure single valve reference can be used for many different applications

ASCO Series 290 switchbox



- Diagnostics to support preventative maintenance strategies, including cycle counting function to determine performance level and probability of a dangerous failure. Optical position status indicator enables operators to quickly check if the valve is operating correctly



- AS-Interface communications simplify installation



- Designed for fast and easy assembling, with IP66 and IP69K enclosures suitable for indoor or outdoor installations and splash zones

ASCO Series 290: Modular solution simplifies commissioning

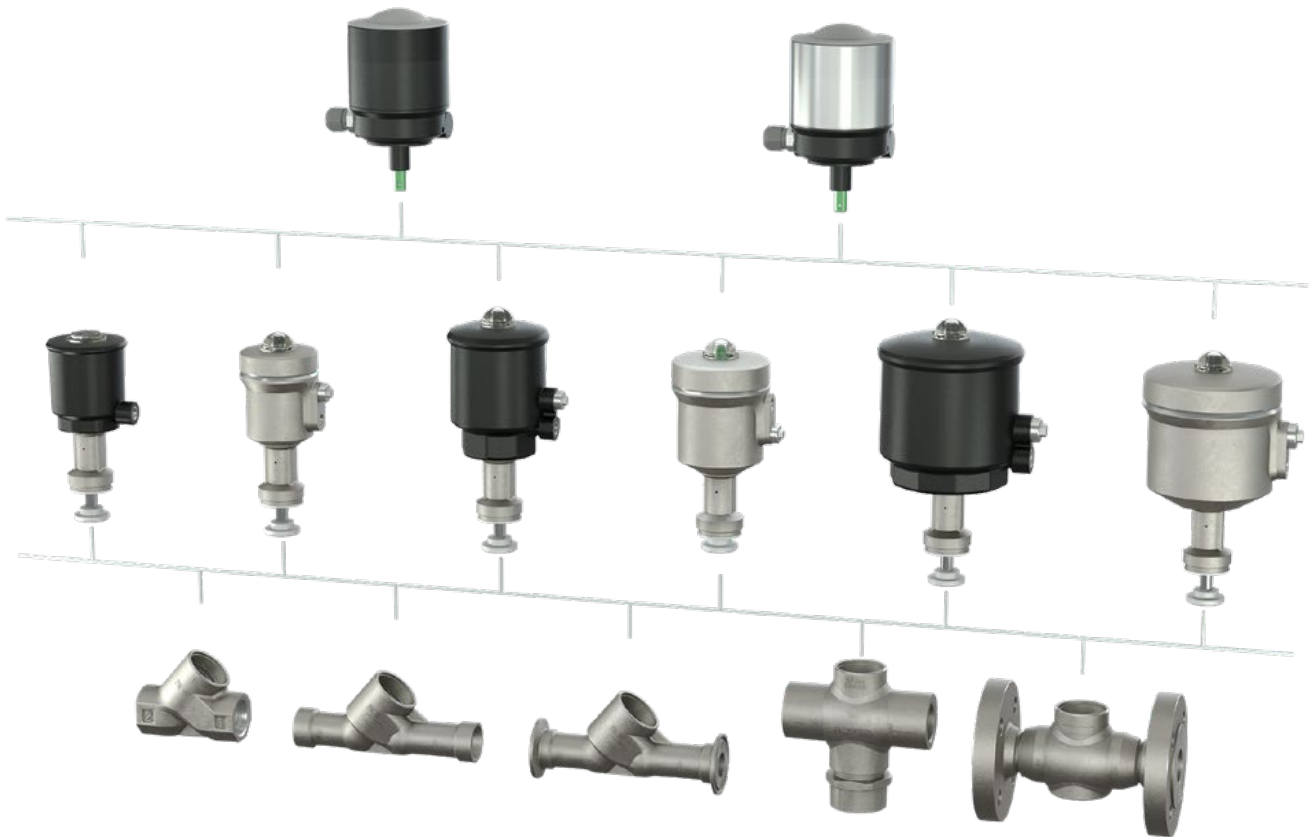

The modularity of the ASCO Series 290 makes it possible to interchange actuators of different size and materials on the same body. This allows quick and easy modification of the valve characteristics after assembly on site. This is very useful when mounting valves on a manifold block. Any combination of the broad range of different sized actuators, bodies and various switchbox types can be used.

- Easy assembly and commissioning
- Fast maintenance renovation and revamps
- Easy retrofitting on the same body

	Series 290 with 316 stainless-steel actuator				Series 290 with polyamid actuator				
	Actuator Size (mm)								
	32	50	63	90	32	50	63	90	125
Body material	DN10 to DN65								
Bronze body PN16						✓	✓	✓	✓
316 stainless-steel body PN16-PN25-PN40	✓	✓	✓	✓	✓	✓	✓	✓	✓
Function									
2-way normally closed	✓	✓	✓	✓	✓	✓	✓	✓	✓
2-way normally open	✓	✓	✓	✓	✓	✓	✓	✓	✓
2-way double acting	✓	✓	✓		✓	✓	✓		
3-way normally closed			✓	✓			✓	✓	✓
3-way normally open			✓	✓			✓	✓	✓
Connection type									
G/Rp (combination of ISO 228-1 and ISO 7-1)	✓	✓	✓	✓	✓	✓	✓	✓	✓
NPT (ANSI 1.20.3)	✓	✓	✓	✓	✓	✓	✓	✓	✓
ISO 7/1 "Rc"	✓	✓	✓	✓	✓	✓	✓	✓	✓
Flange DIN EN 1092-1 (ISO 7005) standard		✓	✓	✓		✓	✓	✓	✓
Flange ANSI standard 150		✓	✓	✓		✓	✓	✓	✓
Butt welding ISO 1127	✓	✓	✓	✓	✓	✓	✓	✓	✓
Butt welding DIN 11850 s2		✓	✓	✓		✓	✓	✓	✓
Butt welding SMS 3017		✓	✓	✓		✓	✓	✓	✓
Butt welding ASME BPE	✓	✓	✓	✓	✓	✓	✓	✓	✓
Clamp ISO 1127	✓	✓	✓	✓	✓	✓	✓	✓	✓
Clamp DIN 11850 s2		✓	✓	✓		✓	✓	✓	✓
Clamp SMS 3008		✓	✓	✓		✓	✓	✓	✓
Clamp ASME BPE	✓	✓	✓	✓	✓	✓	✓	✓	✓
Option type									
Without body for manifold	✓	✓	✓	✓	✓	✓	✓	✓	✓
Combustible gas certified			✓		✓	✓	✓		
Explosive area: ATEX and IECEx	✓	✓	✓	✓	✓	✓	✓	✓	✓
Oxygen service	✓	✓	✓	✓	✓	✓	✓	✓	✓
Saturated steam up to 220°C /428°F		✓	✓	✓					
Low temperature -60°C /-76°F			✓	✓					
CUTR certification (EAC) for product	✓	✓	✓	✓	✓	✓	✓	✓	✓
Stroke limiter for opening		✓	✓	✓		✓	✓	✓	✓
Test tightness: FCI 70-2 class VI	✓	✓	✓	✓	✓	✓	✓	✓	✓
High level of vacuum	✓	✓	✓	✓	✓	✓	✓	✓	✓
Material Certification 3,1	✓	✓	✓	✓	✓	✓	✓	✓	✓
Fugitive emission Class BH			✓						
Specific actuator for Namur pilot		✓	✓	✓			✓	✓	✓
Food contact 1935/2004 and FDA CFR21	✓	✓	✓	✓	✓	✓	✓	✓	✓
Manual override		✓	✓	✓		✓	✓	✓	✓
Switchbox									
Switchbox with position colored LEDs		✓	✓	✓			✓	✓	✓
Switchbox range IP69K		✓	✓	✓			✓	✓	✓
ASI communication		✓	✓	✓			✓	✓	✓
Integrated pilot		✓	✓	✓			✓	✓	✓
Digital positioner range			✓	✓			✓	✓	✓
Diagnostics			✓	✓			✓	✓	✓
Compact signalling units	✓	✓	✓	✓	✓	✓	✓	✓	✓

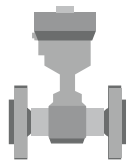

Enhance plant and worker safety,
reduce operating costs and minimize
project time.



ASCO[™]

Designed to simplify your fluid control project challenges, the ASCO Series 290 angle seat valves set new standards in performance and reliability, helping you to improve plant and worker safety and lower operating costs.

Visit us: [Emerson.com/ASCO](https://www.emerson.com/ASCO)

Your local contact: [Emerson.com/contactus](https://www.emerson.com/contactus)



[Emerson.com/ASCO](https://www.emerson.com/ASCO)



[Facebook.com/EmersonAutomationSolutions](https://www.facebook.com/EmersonAutomationSolutions)



[LinkedIn.com/company/Emerson-Automation-Solutions](https://www.linkedin.com/company/Emerson-Automation-Solutions)



[Twitter.com/EMR_Automation](https://twitter.com/EMR_Automation)



valvesales@emerson.com

The Emerson logo is a trademark and service mark of Emerson Electric Co. Brand logotype are registered trademarks of one of the Emerson family of companies. All other marks are the property of their respective owners. © 2021 Emerson Electric Co. All rights reserved. BR000244ENUS-01_06-21



CONSIDER IT SOLVED[™]