



Ultraweld® L20 System

Branson's Ultraweld® L20 system is designed and built to assure you the highest degree of reliability and weld quality.

Branson Ultrasonics Corporation is the world leader in ultrasonic metal joining. We have partnered with industries in many markets including, photovoltaic, medical, automotive, battery, refrigeration, electrical and appliance. Our many years of experience have given us a broad base of applications knowledge.

Ultrasonic metal welding provides our customers with a sound solution, superior performance, improved throughput, and reduced maintenance.

Branson welding systems are designed and built to ensure the highest degree of reliability and weld quality.

The Branson Ultraweld 20 system offers the following features:

- A precision roller bearing slide to assure smooth operation and extreme accuracy.
- Precise adjustments for accurate setting of both upper and lower positive stops.
- Conveniently located flow controls offering easy adjustment of head speed in both directions.
- A polar mounted ultrasonic stack to facilitate linear and axial setup and efficient transmission of ultrasonic energy to the horn.
- Titanium horns with low cost replaceable tips or solid tool steel horns for fast setup and minimum tooling cost.
- Fixturing which is changed quickly and easily for various applications by means of a dovetail mounting.
- Optional vortex cooling to allow high-speed operation without heat buildup.

Ultrasonic Welding

- Ultraweld® L20 - 20 kHz Welding System rugged and easily tooled for a wide range of nonferrous welding applications.

Welding Power: 4.0kW & 6.0kW

Electrical: 220VAC, 50/60 Hz, 20 Amp.

Compressed Air: clean, dry 80 psig (5.5 bar)

Make the Branson Connection

Ultrasonic metal welding is the most technologically advanced method of bonding conductive metals such as aluminum, copper, and brass.

For nearly three decades, Branson has pioneered the development of high quality welders that produce a variety of products ranging from wire terminations to solar panels.

Branson's ergonomically designed systems offer manufacturers the fastest and cleanest method of reliably assembling components.

With cycle times of under one second and Branson's Intelligent Process Controls productivity and quality are maximized.

Unending commitments to process improvement, application advancement, engineering excellence and customer service are the attributes which have made Branson the world leader in ultrasonic metal welding technology.

Advantages of Ultrasonics

Reliability: Ultrasonic welding can be monitored through time, energy, power, and height limits, assuring excellent process control.

Cost Savings: Elimination of consumables such as solder, flux, crimp connectors and braze materials make ultrasonic welding the most cost effective and environmentally safe process available for welding.

Tool Life: Multi-lobe ultrasonic tools are precision machined from high quality tool steel, providing long life, ease of setup, and weld accuracy.

Speed: Typical weld cycles are under 0.5 seconds.

Low operating costs: Ultrasonics require less than 1/30 of the energy of resistance welding.

Automation potential: Efficient size, minimal maintenance and orientation flexibility make Branson ultrasonic equipment the best choice for automatic assembly.

Low operating temperature: Since ultrasonic welding does not generate appreciable heat, it will not anneal metal parts or require cooling water.

Insulation dispersal: In most cases, the high frequency scrubbing action of the ultrasonic process eliminates the need to strip insulation from magnet wire or to preclean parts.

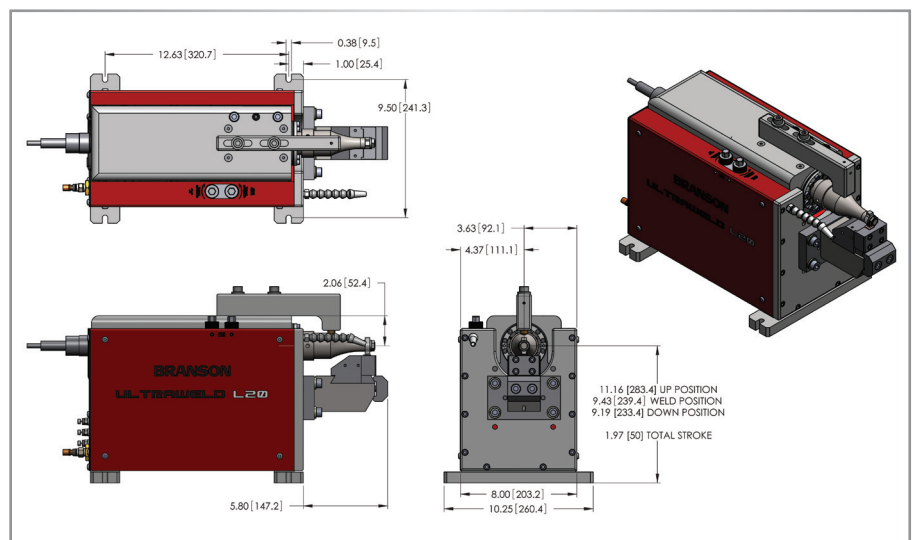

BRANSON

Branson Ultrasonics Corporation
41 Eagle Road, Danbury, CT 06813-1961
(203) 796-0400 • Fax: (203) 796-9838
www.bransonultrasonics.com
e-mail: info@bransonultrasonics.com

Ultraweld® L20 © Branson Ultrasonics Corporation 2011
The Emerson logo is a trademark and service mark of Emerson Electric Co.
Revised and printed in the U.S.A. 3/2012