

## Series CH01



AVENTICS™ Series CH01



# Series CH01

- Qn = 38-2800 l/min

- Internal thread / Internal thread



Working pressure min./max.	0 ... 10 bar
Ambient temperature min./max.	0 ... 80 °C
Medium temperature min./max.	0 ... 80 °C
Medium	Compressed air
Weight	See table below



## Technical data

Part No.	Port 1	Port 2	Throttle bore	Flow	Weight	Fig.
			Ø	Qn		
0821201010	G 1/8	G 1/8	1 mm	38 l/min	0.035 kg	Fig. 1
0821201004	G 1/8	G 1/8	2 mm	140 l/min	0.035 kg	Fig. 1
0821201011	G 1/4	G 1/4	4 mm	700 l/min	0.045 kg	Fig. 1
0821201006	G 1/2	G 1/2	8.5 mm	2800 l/min	0.17 kg	Fig. 2

Nominal flow Qn at 6 bar and  $\Delta p = 1$  bar

## Technical information

Material	
Housing	Aluminum, anodized
Seals	Acrylonitrile butadiene rubber
Flow control screw	Steel, galvanized

## Dimensions

Fig. 1

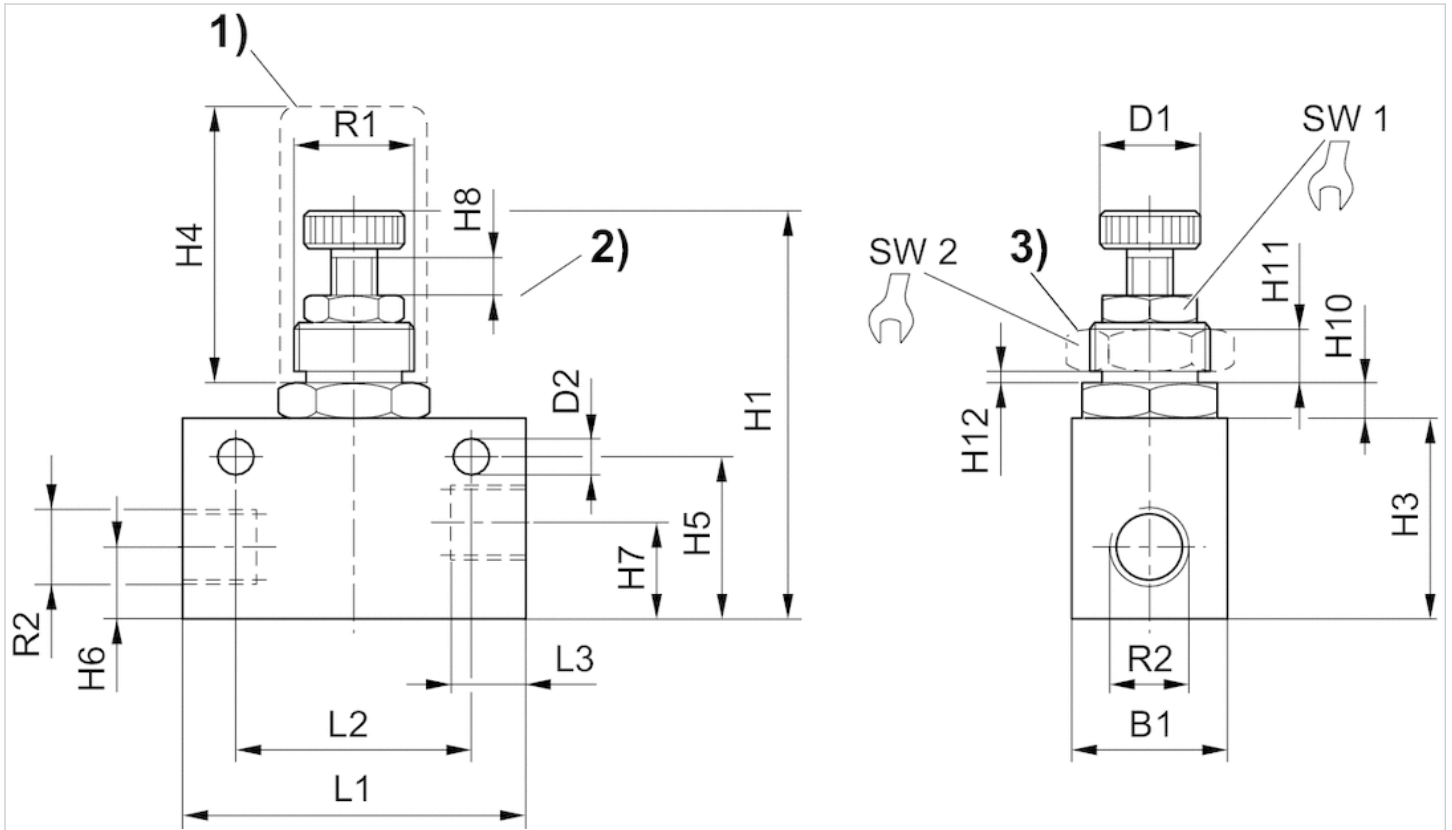

1) protective cap 2) throttle setting range 3) nut for control panel installation

## Dimensions

Part No.	Port G	R1	R2	B1	D1	D2	H1	H3	H4	H5	H6	H7	H8	H10	H11	H12	L1	L2	L3
0821201010	G 1/8	M12x1	G 1/8	16	9,8	4,5	56	20	35	16,5	8	8	4	4,2	4	0	35	25	8
0821201004	G 1/8	M12x1	G 1/8	16	9,8	4,5	56	20	35	16,5	8	8	4	4,2	4	0	35	25	8
0821201011	G 1/4	M20x1,5	G 1/4	25	15	5,5	70	32	40	26	11	15	5	5,5	6	0	55	38	12

SW1	SW2
10	17
10	17
13	24

## Dimensions

Fig. 2

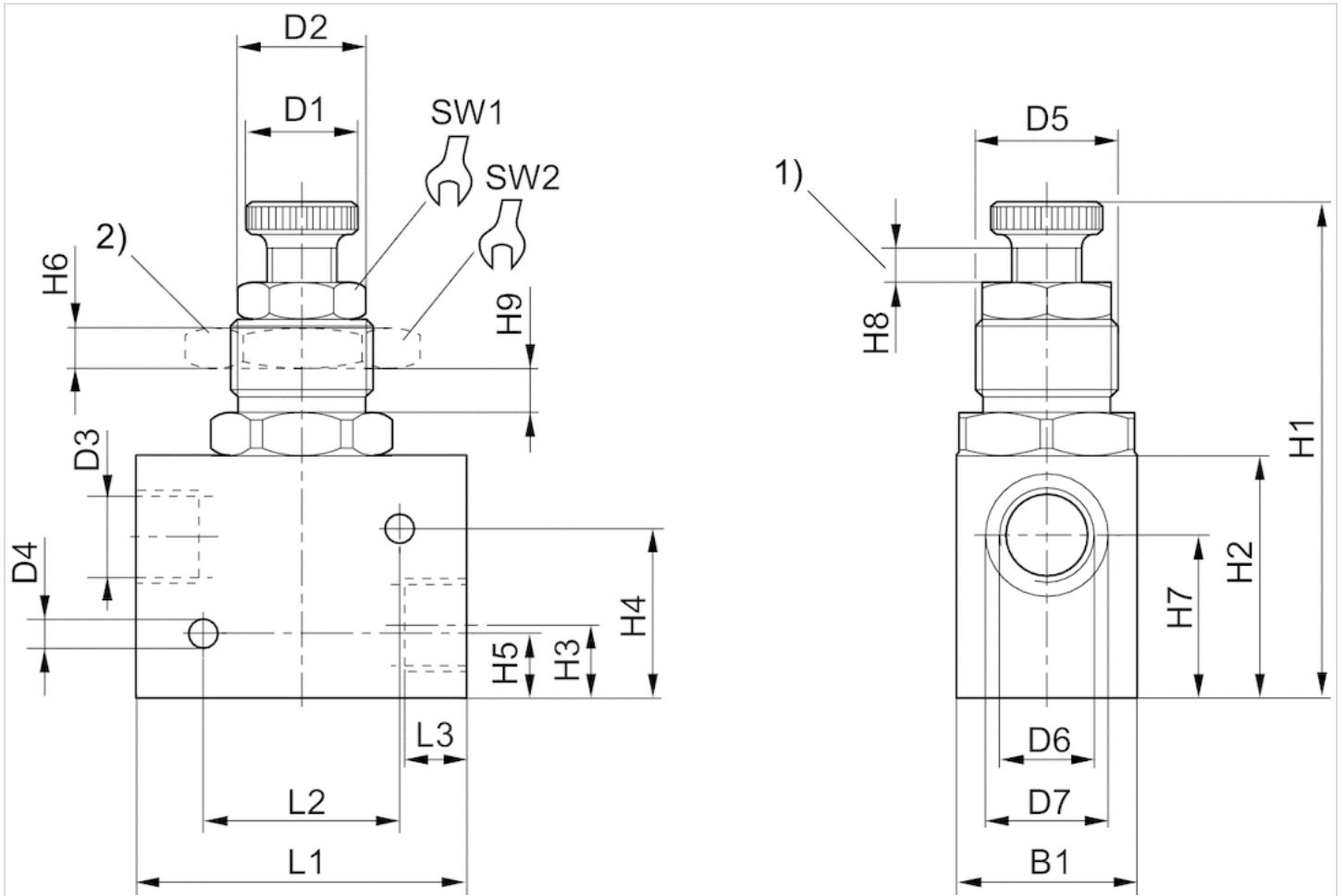

1) throttle setting range 2) nut for control panel installation

## Dimensions

Part No.	Port G	D1	D2	D3	D4	D5	D6	D7	B1	H1	H2	H3	H4	H5	H6	H7	H8	H9	L1	L2
0821201006	G 1/2	27	27,5	19	6,5	M32x1,5	G1/2	27	40	120	50	17	40.5	15.5	9	38	8	9	75.3	45
					L3					SW1					SW2					
					14					24					46					

# Protective cap



Weight

See table below

## Technical data

Part No.	Delivery unit	Weight
1823317003	10 piece	0.002 kg
1823317002	10 piece	0.004 kg

## Dimensions

### Dimensions

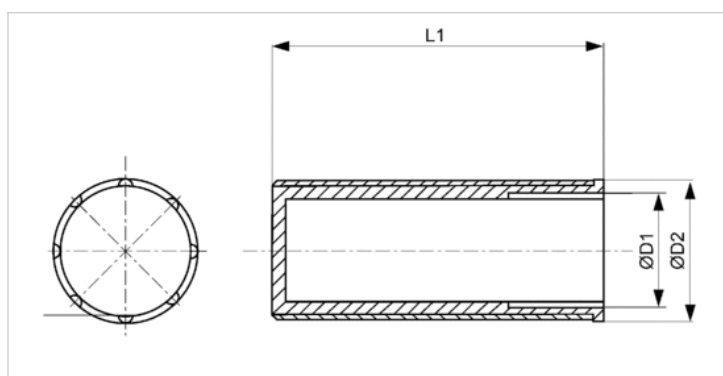

## Dimensions

Part No.	Ø D1	Ø D2	L1
1823317003	M12x1	15	35
1823317002	M20x1,5	24	40

# Hexagonal nut for panel installation



## Technical data

Part No.	Thread connection	Delivery unit
1823300009	M20x1,5	10 piece
1823300010	M32x1,5	5 piece

## Dimensions

### Dimensions

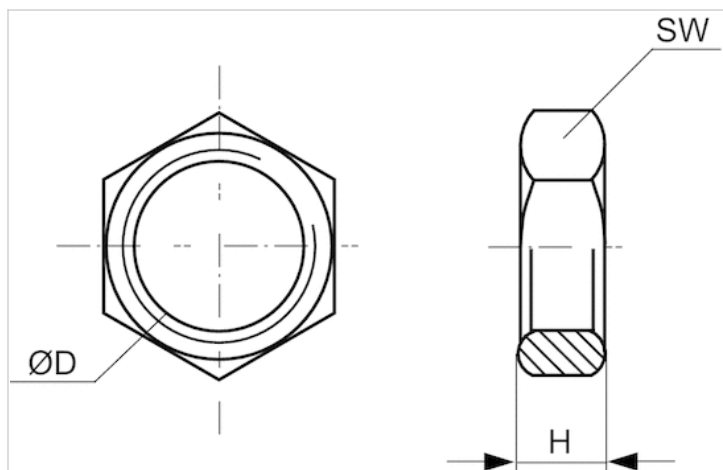

## Dimensions

Part No.	Ø D	H	SW
1823300009	M20x1,5	6	24
1823300010	M32x1,5	9	46

# Efficient pneumatic solutions, our program: cylinders and drives, valves and valve systems, air supply management



Visit us: [Emerson.com/Aventics](http://Emerson.com/Aventics)

Your local contact: [Emerson.com/contactus](http://Emerson.com/contactus)



[Emerson.com](http://Emerson.com)



[Facebook.com/EmersonAutomationSolutions](https://Facebook.com/EmersonAutomationSolutions)



[LinkedIn.com/company/Emerson-Automation-Solutions](https://LinkedIn.com/company/Emerson-Automation-Solutions)



[Twitter.com/EMR\\_Automation](https://Twitter.com/EMR_Automation)

An example configuration is depicted on the title page. The delivered product may thus vary from that in the illustration. Subject to change. This Document, as well as the data, specifications and other information set forth in it, are the exclusive property of AVENTICS GmbH. It may not be reproduced or given to third parties without its consent. Only use the AVENTICS products shown in industrial applications. Read the product documentation completely and carefully before using the product. Observe the applicable regulations and laws of the respective country. When integrating the product into applications, note the system manufacturer's specifications for safe use of the product. The data specified only serve to describe the product. No statements concerning a certain condition or suitability for a certain application can be derived from our information. The information given does not release the user from the obligation of own judgment and verification. It must be remembered that the products are subject to a natural process of wear and aging.

The Emerson logo is a trademark and service mark of Emerson Electric Co. Brand logotype are registered trademarks of one of the Emerson family of companies. All other marks are the property of their respective owners. © 2017 Emerson Electric Co. All rights reserved.  
2019-03



**CONSIDER IT SOLVED™**