

Series CKP

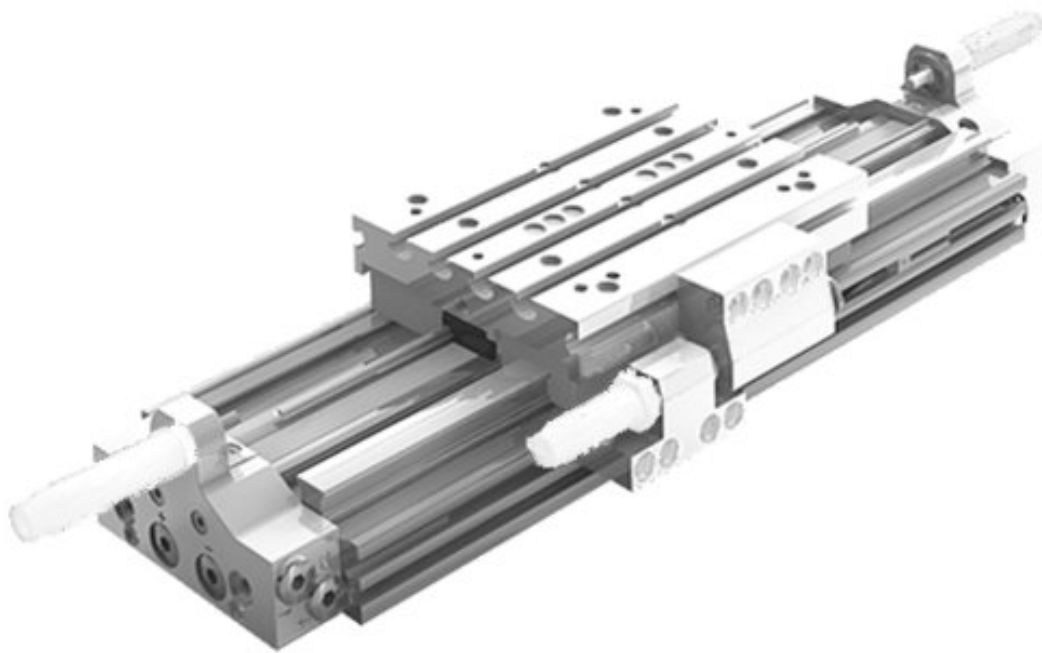

AVENTICS™ Series CKP



Rodless cylinders, Series CKP

- Ø 16-32 mm
- Ports M7 G 1/8
- double-acting
- with magnetic piston
- ball rail guide
- Cushioning pneumatically adjustable
- Easy2Combine capable with connection kit

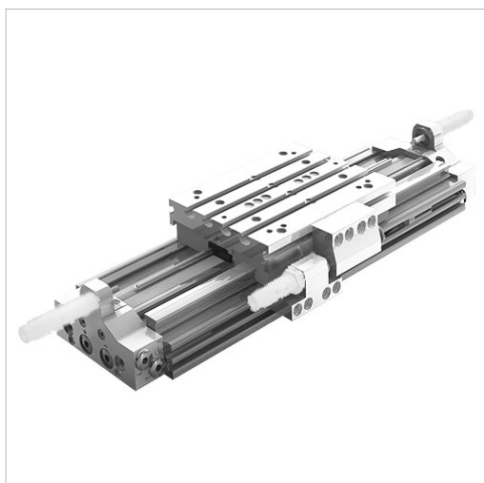

Working pressure min./max.	3 ... 8 bar
Ambient temperature min./max.	-10 ... 60 °C
Medium temperature min./max.	-10 ... 60 °C
Medium	Compressed air
Max. particle size	5 µm
Pressure for determining piston forces	6.3 bar
Weight	See table below

An example configuration is illustrated.
The delivered product may thus deviate from the illustration.

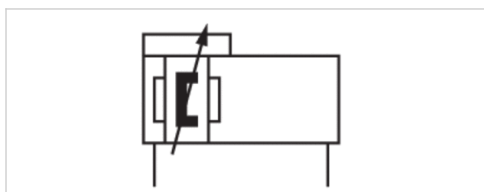

Technical data

Piston Ø	16 mm	25 mm	32 mm
Stroke 100	R480163938	R480163948	R480163958
200	R480163939	R480163949	R480163959
300	R480163940	R480163950	R480163960
400	R480163941	R480163951	R480163961
500	R480163942	R480163952	R480163962
600	R480163943	R480163953	R480163963
700	R480163944	R480163954	R480163964
800	R480163945	R480163955	R480163965
900	R480163946	R480163956	R480163966
1000	R480163947	R480163957	R480163967

Technical data

Piston Ø	16 mm	25 mm	32 mm
Piston force	127 N	309 N	507 N
Cushioning length	20 mm	20 mm	20 mm
Cushioning energy	1.5 J	4 J	7 J

Piston Ø	16 mm	25 mm	32 mm
Speed max.	2 m/s	2 m/s	2 m/s
Stroke max.	1800 mm	3700 mm	3700 mm

Technical information

The pressure dew point must be at least 15 °C under ambient and medium temperature and may not exceed 3 °C .

The delivered product is lubricated for lifetime.

This product may only be operated with oil-free, dry compressed air.

SA = stroke adjustment with use of shock absorber.

Adjustment made with adjustment screw.

Shock absorber can be replaced without readjustment of end position.

Technical information

Material	
Cap	Aluminum, anodized
Seal	Polyurethane
Sealing strips	Polyurethane Stainless steel
Ball rail table	Aluminum, anodized
Guide rail	Steel, hardened

Dimensions

Piston Ø	B	E	BU	CC	EE	FH	GA	GB	GC	GD	GN	GE	GF	GH	GI	GJ	GK	GL	GM	GT	GU
16 mm	90	27.3	125	28	M7	56	15	20	20	20	93.5	38.5	110	20	40	40	60	80	-	57	80
25 mm	110	31.4	155	28	G 1/8	66	25	20	20	20	107.5	47.5	120	42	80	40	60	80	-	66	106
32 mm	145	37.8	190	28	G 1/8	85	19	40	27	40	120	40	160	35	80	40	80	120	80	88	111

Piston Ø	MC	PL	PM	PO	PP	PS	PT	PU	PW	Q1	Q2	Q3	RG	Ø RP
16 mm	93.5	8	21	12.8	6.8	33	29.8	6.8	6	73.5	40	-	M5	9 F7
25 mm	107.5	8	20	22	10.5	37.5	24	10.5	10.5	87.5	40	12.5	M5	9 F7
32 mm	120	8	19	23.8	10.3	57	51	12	12	100	40	12.5	M6	12 F7

Piston Ø	RQ t = depth of thread	Ø RR	Ø RS	RT	Ø RU	SG	SL	SU	SW	T	TT	W1	W2	T1
16 mm	M5 t=10,5	4 F7	9 F7	M6	12 F7	20.3	43	37	20	M4	N6	112	102	16
25 mm	M6 t=14,5	5 F7	12 F7	M6	12 F7	14	60	43	23	N6	N6	140	126	20
32 mm	M6 t=14,5	6 F7	12 F7	M6	12 F7	32.5	60	59	23	N6	N8	175	161	23

Piston Ø	ZD	SA	Moving mass kg
16 mm	187	0-10	0.64
25 mm	215	0-10	1.11
32 mm	240	0-10	2.62

Weight [kg]

Piston Ø	S	Weight kg
16 mm	100	2.18 kg
16 mm	200	2.65 kg
16 mm	300	3.13 kg
16 mm	400	3.6 kg
16 mm	500	4.08 kg
16 mm	600	4.56 kg
16 mm	700	5.03 kg
16 mm	800	5.51 kg
16 mm	900	5.98 kg
16 mm	1000	6.46 kg
25 mm	100	3.88 kg
25 mm	200	4.69 kg
25 mm	300	5.49 kg
25 mm	400	6.29 kg
25 mm	500	7.1 kg
25 mm	600	7.9 kg
25 mm	700	8.7 kg
25 mm	800	9.5 kg
25 mm	900	10.31 kg
25 mm	1000	11.11 kg
32 mm	100	7.5 kg
32 mm	200	8.77 kg
32 mm	300	10.04 kg
32 mm	400	11.31 kg

Piston Ø	S	Weight kg
32 mm	500	12.58 kg
32 mm	600	13.85 kg
32 mm	700	15.12 kg
32 mm	800	16.39 kg
32 mm	900	17.66 kg
32 mm	1000	18.93 kg

S = stroke

Dimensions

Permissible forces F_x, F_y, F_z and torques M_x, M_y, M_z

$$\frac{M_x}{M_{x_{max.}}} + \frac{M_y}{M_{y_{max.}}} + \frac{M_z}{M_{z_{max.}}} \leq 1$$

With simultaneously moments on the cylinder this equation must be used in addition to the maximum moments check. In the cushioning phase of the movement additional forces occur and must be considered. Please use our calculation tool for rodless cylinders on the <http://www.aventics.com>.

Permissible forces F_x, F_y, F_z and torques M_x, M_y, M_z

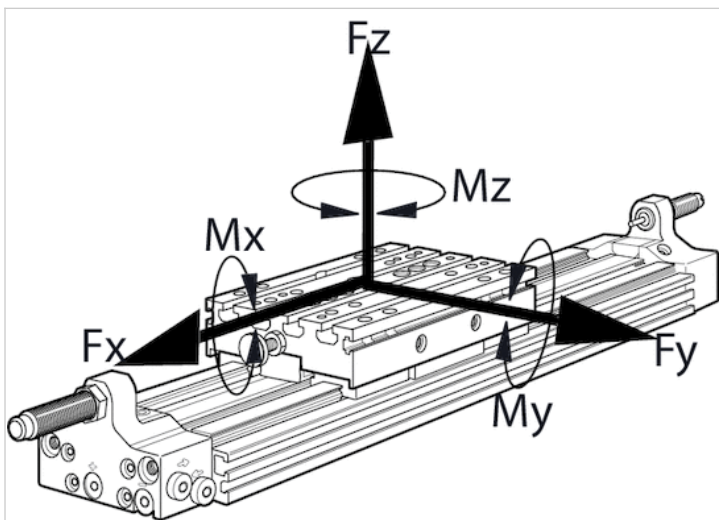

With simultaneously moments on the cylinder this equation must be used in addition to the maximum moments check. In the cushioning phase of the movement additional forces occur and must be considered. Please use our calculation tool for rodless cylinders on the <http://www.aventics.com>.

Max. dynamic forces and torques

Piston Ø	F_x [N]	F_y [N]	F_z [N]	M_x [Nm]	M_y [Nm]	M_z [Nm]
16 mm	2912	2912	2912	83	116	143
25 mm	3280	3280	8568	283	454	205
32 mm	5280	5280	15620	687	867	374

Recommended values for an expected lifetime of 3200 km

Diagrams

Horizontally mounted, with pneumatic cushioning

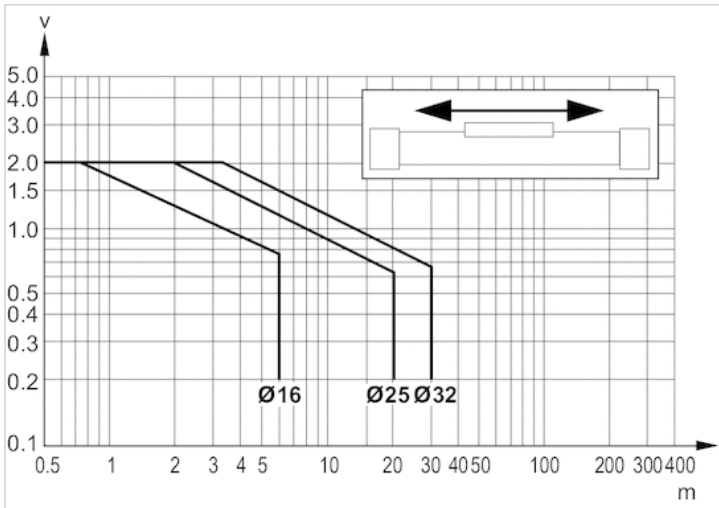

v = Piston velocity [m/s]
m = Cushionable mass [kg]

Vertically mounted, with pneumatic cushioning

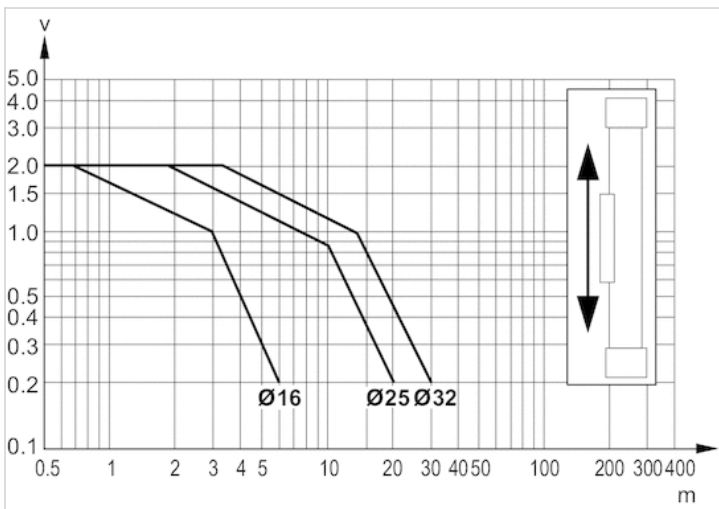

v = Piston velocity [m/s]
m = Cushionable mass [kg]

CKP is part of the compact module family.

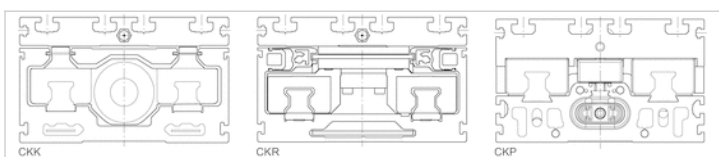

Further information can be found in the operating instructions.

fastening a customer attachment onto the CRP with T-groove nuts.

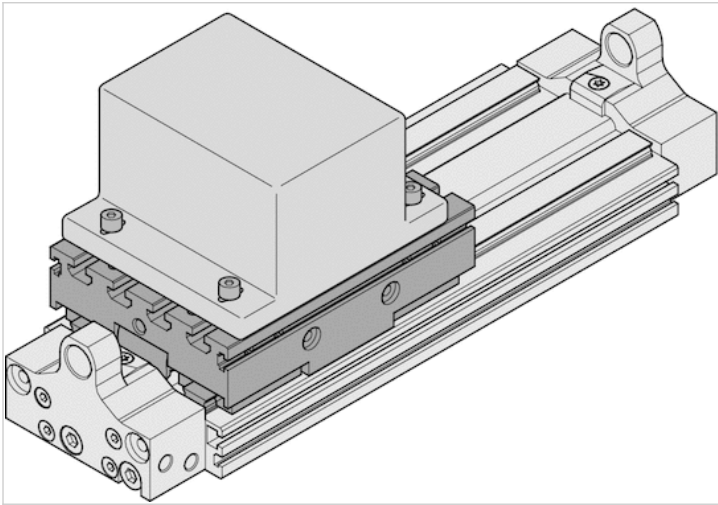

fastening of automation system Easy2Combine to CRP using center rings and T-groove nuts (example: mini slide MSC)

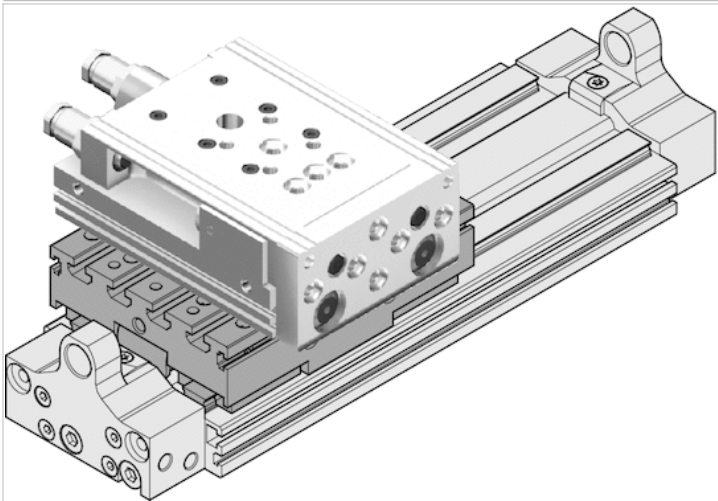

fastening of CRP to customer-built mounting base via clamping fixtures

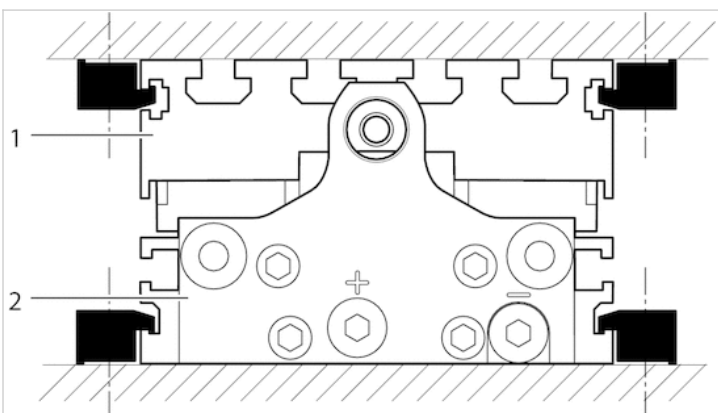

fastening of CKP on BME (Basic mechanical elements) profile construction via connection plates and clamping fixtures

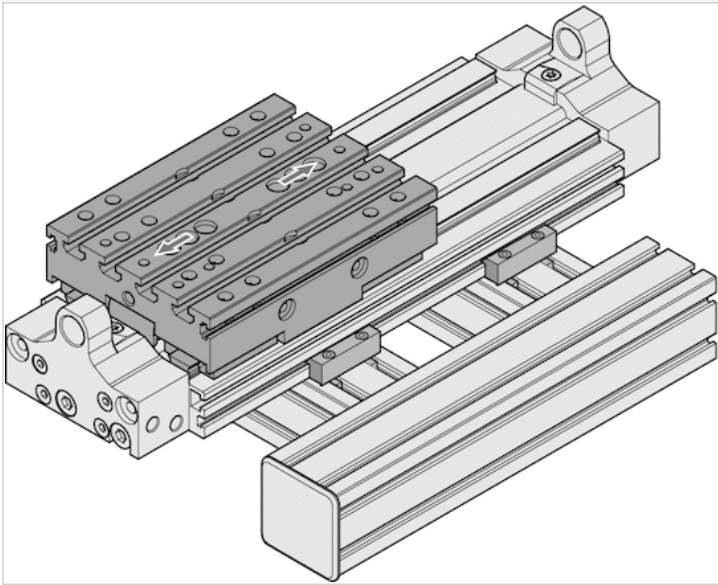

Rodless cylinders, Series CKP-CL

- Ø 16-32 mm
- Ports M7 G 1/8
- double-acting
- with magnetic piston
- ball rail guide
- Cushioning pneumatically adjustable
- Easy2Combine capable with electrical axes

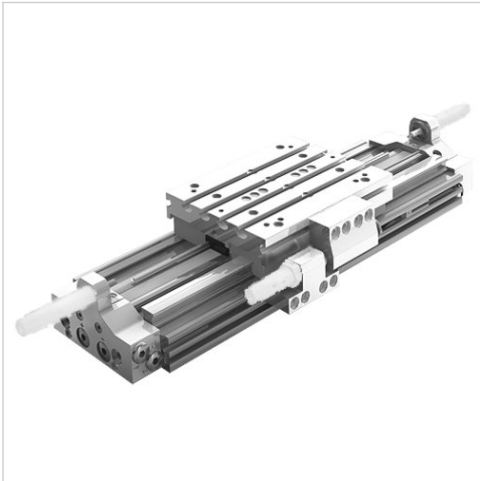

Working pressure min./max.	3 ... 8 bar
Ambient temperature min./max.	-10 ... 60 °C
Medium temperature min./max.	-10 ... 60 °C
Medium	Compressed air
Max. particle size	5 µm
Pressure for determining piston forces	6.3 bar
Weight	See table below

An example configuration is illustrated.
The delivered product may thus deviate from the illustration.

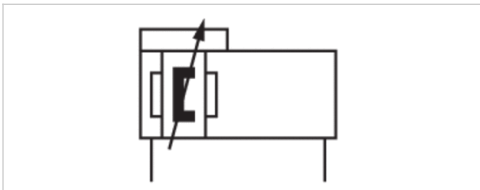

Technical data

Piston Ø	16 mm	25 mm	32 mm
Stroke 200	R480163968	R480163978	R480163988
320	R480163969	R480163979	R480163989
400	R480163970	R480163980	R480163990
520	R480163971	R480163981	R480163991
600	R480163972	R480163982	R480163992
800	R480163973	R480163983	R480163993
1000	R480163974	R480163984	R480163994
1240	R480163975	R480163985	R480163995

Technical data

Piston Ø	16 mm	25 mm	32 mm
Piston force	127 N	309 N	507 N
Cushioning length	20 mm	20 mm	20 mm
Cushioning energy	1.5 J	4 J	7 J
Speed max.	2 m/s	2 m/s	2 m/s
Stroke max.	1400 mm	1400 mm	1400 mm

Technical information

The pressure dew point must be at least 15 °C under ambient and medium temperature and may not exceed 3 °C .
The delivered product is lubricated for lifetime.
This product may only be operated with oil-free, dry compressed air.

Technical information

Material	
Cap	Aluminum, anodized
Seal	Polyurethane
Sealing strips	Polyurethane Stainless steel
Ball rail table	Aluminum, anodized
Guide rail	Steel, hardened

Dimensions

Dimensions

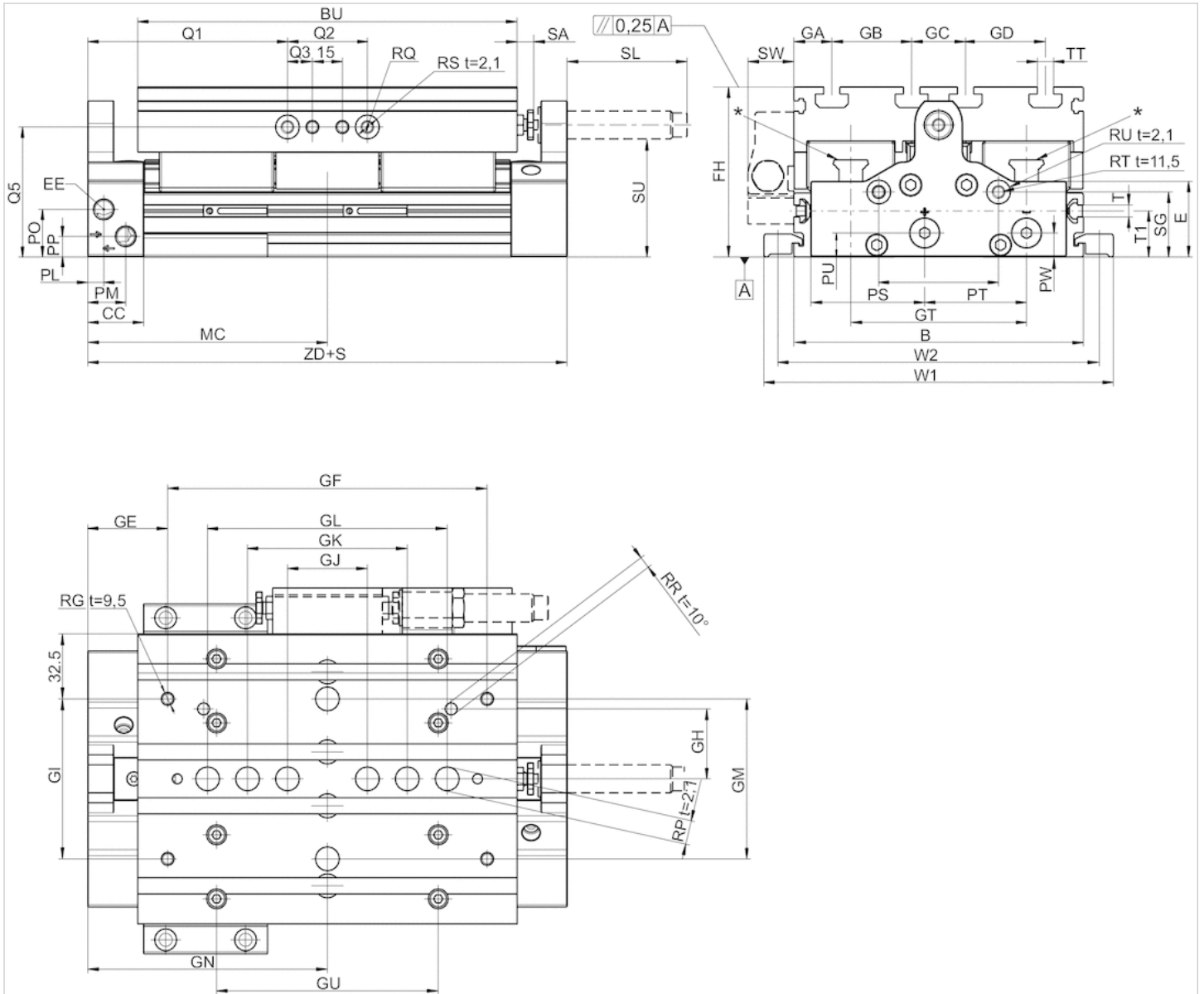

t = depth

* CKP 16: 2x Lube ports on each runner block, CKP 25 / 30: Lube nipple of funnel type with thread connection M3

Dimensions

Piston Ø	B	E	BU	CC	EE	FH	GA	GB	GC	GD	GN	GE	GF	GH	GI	GJ	GK	GL	GM	GT	GU
16 mm	90	27.3	125	28	M7	56	15	20	20	20	93.5	38.5	110	20	40	40	60	80	-	57	80
25 mm	110	31.4	155	28	G 1/8	66	25	20	20	20	107.5	47.5	120	42	80	40	60	80	-	66	106
32 mm	145	37.8	190	28	G 1/8	85	19	40	27	40	120	40	160	35	80	40	80	120	80	88	111

Piston Ø	MC	PL	PM	PO	PP	PS	PT	PU	PW	Q1	Q2	Q3	RG	Ø RP
16 mm	93.5	8	21	12.8	6.8	33	29.8	6.8	6	73.5	40	-	M5	9 F7
25 mm	107.5	8	20	22	10.5	37.5	24	10.5	10.5	87.5	40	12.5	M5	9 F7
32 mm	120	8	19	23.8	10.3	57	51	12	12	100	40	12.5	M6	12 F7

Piston Ø	RQ t = depth of thread	Ø RR	Ø RS	RT	Ø RU	SG	SL	SU	SW	T	TT	W1	W2	T1
16 mm	M5 t=10,5	4 F7	9 F7	M6	12 F7	20.3	43	37	20	M4	N6	112	102	16
25 mm	M6 t=14,5	5 F7	12 F7	M6	12 F7	14	60	43	23	N6	N6	140	126	20
32 mm	M6 t=14,5	6 F7	12 F7	M6	12 F7	32.5	60	59	23	N6	N8	175	161	23

Piston Ø	ZD	SA	Moving mass kg
16 mm	187	0-10	0.64
25 mm	215	0-10	1.11
32 mm	240	0-10	2.62

Weight [kg]

Piston Ø	S	Weight kg
16 mm	200	2.65 kg
16 mm	320	3.22 kg
16 mm	400	3.6 kg
16 mm	520	4.18 kg
16 mm	600	4.56 kg
16 mm	800	5.51 kg
16 mm	1000	6.46 kg
16 mm	1240	7.6 kg
25 mm	200	4.69 kg
25 mm	320	5.65 kg
25 mm	400	6.29 kg
25 mm	520	7.26 kg
25 mm	600	7.9 kg
25 mm	800	9.5 kg
25 mm	1000	11.11 kg
25 mm	1240	13.04 kg
32 mm	200	8.77 kg
32 mm	320	10.29 kg
32 mm	400	11.31 kg
32 mm	520	12.83 kg
32 mm	600	13.85 kg
32 mm	800	16.39 kg
32 mm	1000	18.93 kg
32 mm	1240	21.98 kg

S = stroke

Dimensions

Additional Easy2Combine interface on CKP-CL

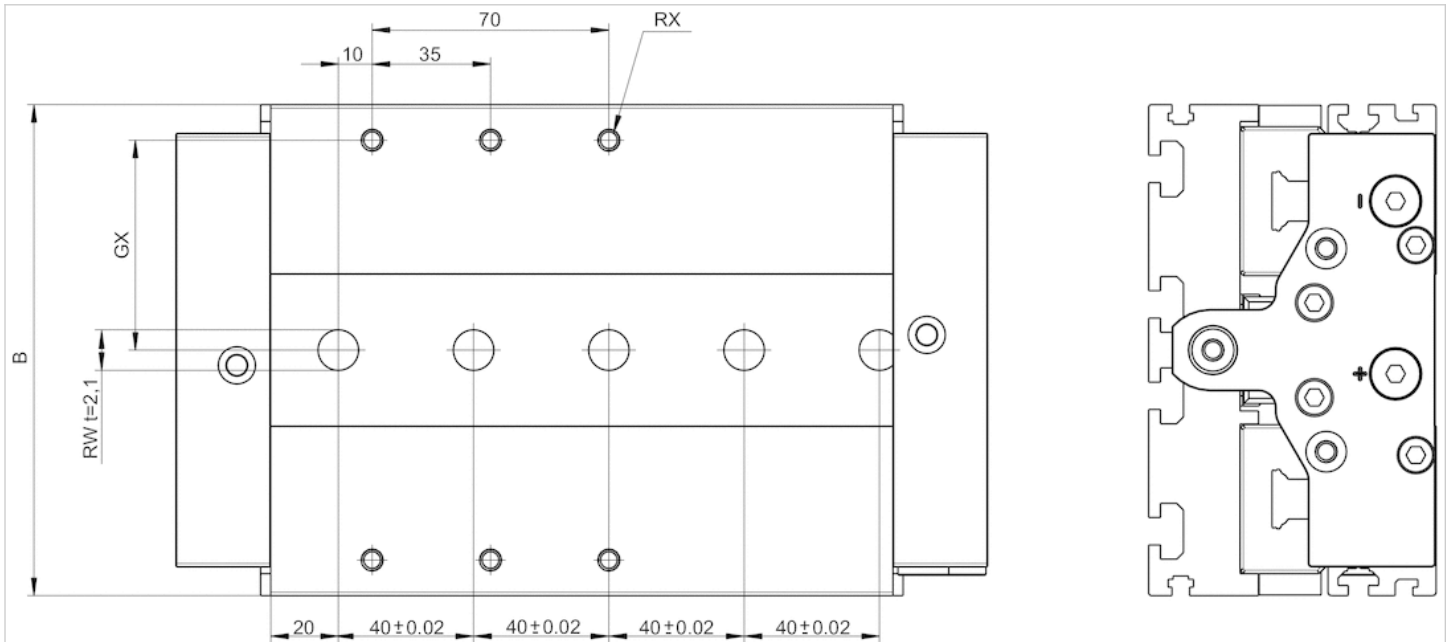

Dimensions

Piston Ø	B	Ø RW t = depth of thread	RX t = depth of thread	GX
16 mm	90	9 H7 t=2,1	M4 t=7,5	38
25 mm	110	9 H7 t=2,1	M5 t=9	46
32 mm	145	12 H7 t=2,1	M6 t=13	62

Dimensions

Permissible forces F_x, F_y, F_z and torques M_x, M_y, M_z

$$\frac{M_x}{M_{x_{max.}}} + \frac{M_y}{M_{y_{max.}}} + \frac{M_z}{M_{z_{max.}}} \leq 1$$

With simultaneously moments on the cylinder this equation must be used in addition to the maximum moments check. In the cushioning phase of the movement additional forces occur and must be considered. Please use our calculation tool for rodless cylinders on the <http://www.aventics.com>.

Permissible forces F_x, F_y, F_z and torques M_x, M_y, M_z

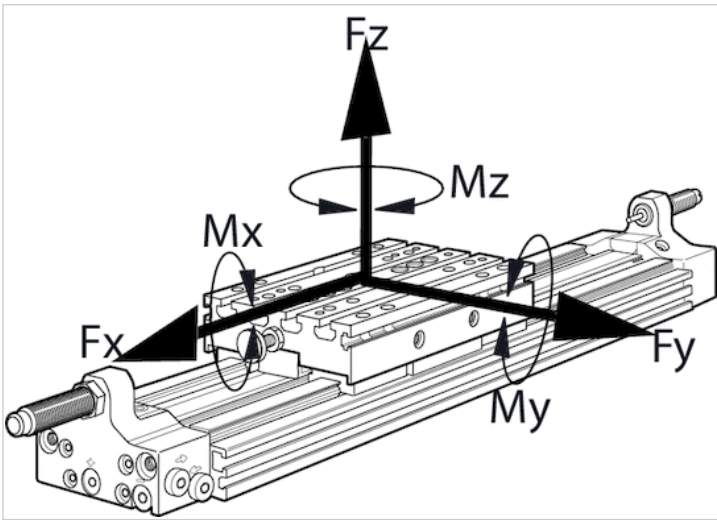

With simultaneously moments on the cylinder this equation must be used in addition to the maximum moments check. In the cushioning phase of the movement additional forces occur and must be considered. Please use our calculation tool for rodless cylinders on the <http://www.aventics.com>.

Max. dynamic forces and torques

Piston Ø	F_x [N]	F_y [N]	F_z [N]	M_x [Nm]	M_y [Nm]	M_z [Nm]
16 mm	2912	2912	2912	83	116	143
25 mm	3280	3280	8568	283	454	205
32 mm	5280	5280	15620	687	867	374

Recommended values for an expected lifetime of 3200 km

Diagrams

Horizontally mounted, with pneumatic cushioning

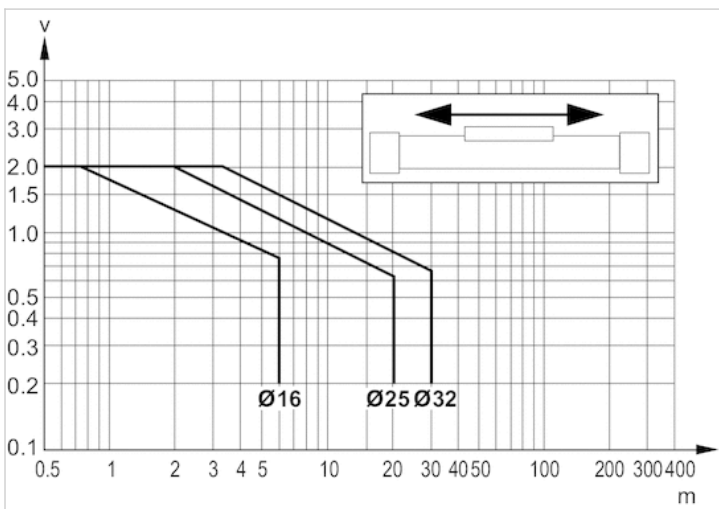

v = Piston velocity [m/s]
 m = Cushionable mass [kg]

Vertically mounted, with pneumatic cushioning

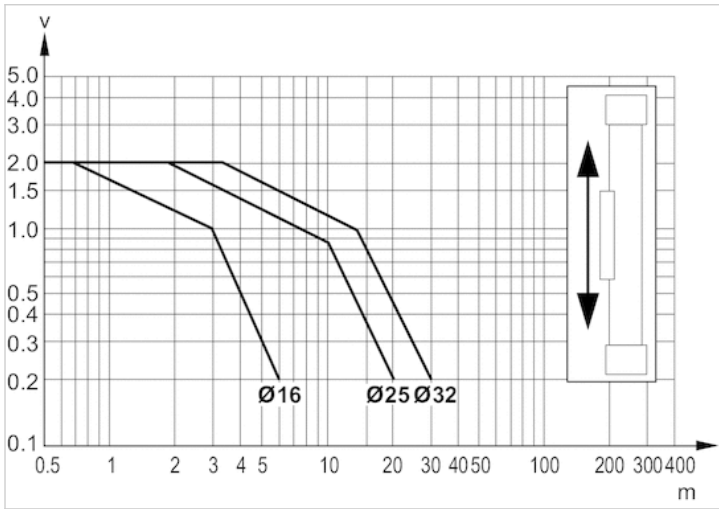

v = Piston velocity [m/s]
 m = Cushionable mass [kg]

CKP is part of the compact module family.

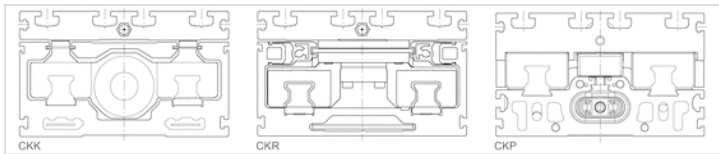

Further information can be found in the operating instructions.

fastening a customer attachment onto the CKP with T-groove nuts.

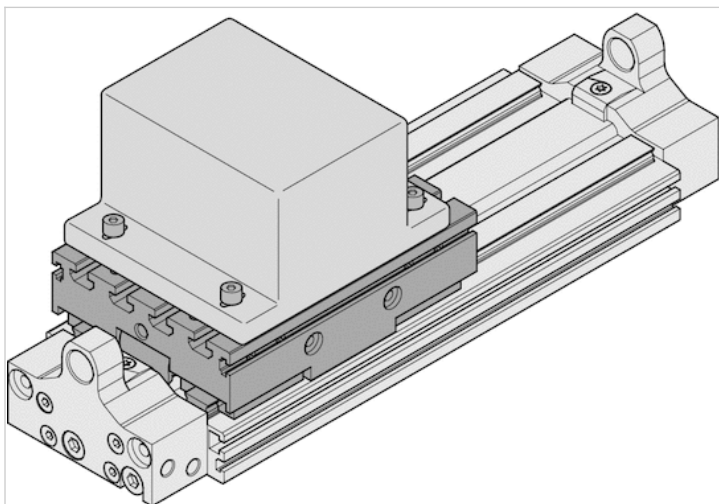

fastening of automation system Easy2Combine to CKP using center rings and T-groove nuts (example: mini slide MSC)

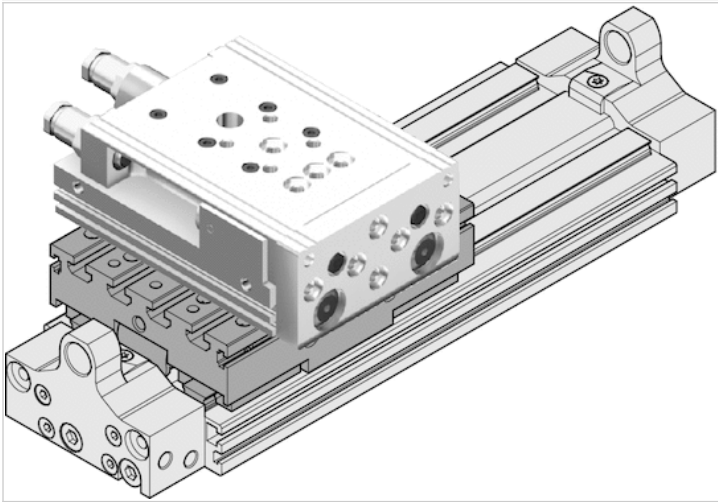

fastening of CKP to customer-built mounting base via clamping fixtures

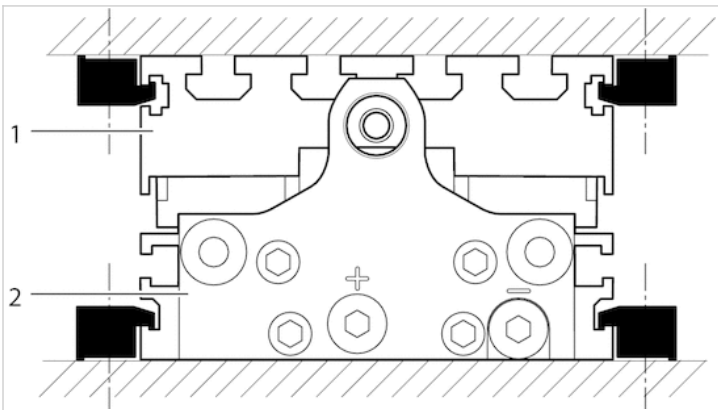

fastening of CKP on BME (Basic mechanical elements) profile construction via connection plates and clamping fixtures

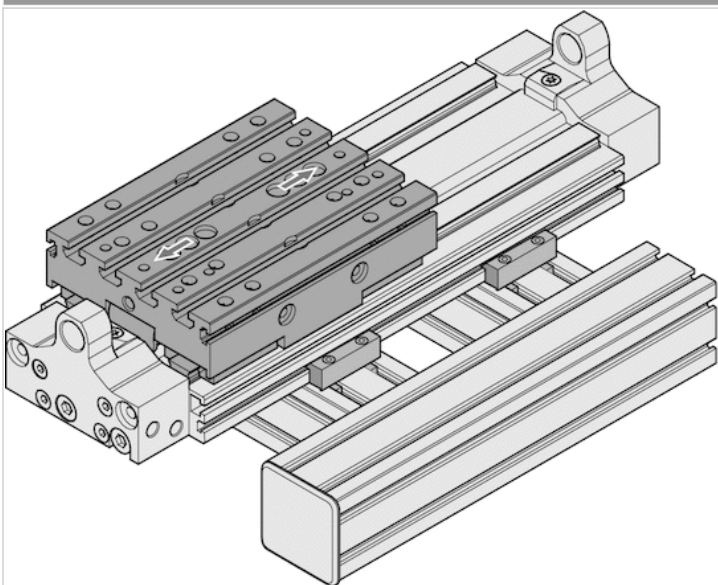

Clamping fixtures

- for series CKP-16, MSC-20 CKP-25, CKP-32, MSC-25



Technical data

Part No.
R037531000
R037531032
R037531033
R037531026
R037541026
R037551000
R037551033
R037551034

Technical information

Material	
Material	Aluminum

Dimensions

Clamping fixtures

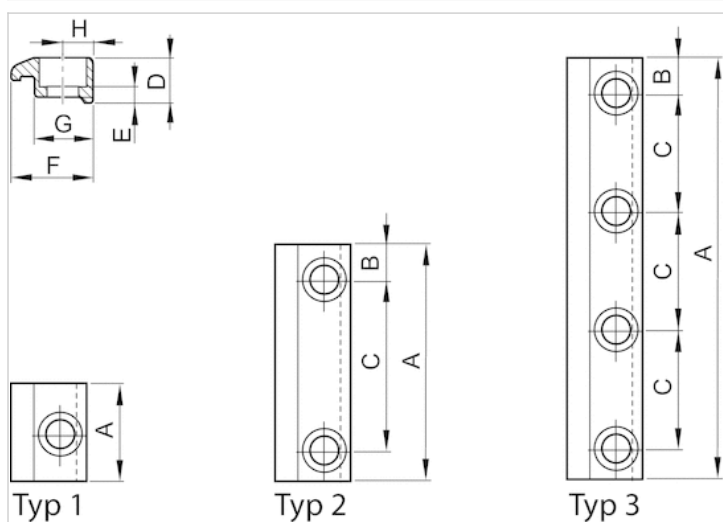

Dimensions

Part No.	1)	Typ	A	B	C	D	E	F	G	H
R037531000	M4	1	25	-	-	9	4.6	14.5	10.5	5
R037531032	M4	2	72	11	50	9	4.6	14.5	10.5	5
R037531033	M4	2	62	11	40	9	4.6	14.5	10.5	5
R037531026	M4	3	77	8.5	20	9	4.6	14.5	10.5	5
R037541026	M5	3	77	8.5	20	11.5	4.8	19.3	14	7
R037551000	M6	1	25	-	-	11.5	5.3	19.3	14	7
R037551033	M6	2	72	11	50	11.5	5.3	19.3	14	7
R037551034	M6	2	62	11	40	11.5	5.3	19.3	14	7

1) countersink for screw

Shock absorber kit for stroke length adjustment



Technical data

Part No.	for series	Cushioning hardness	Diameter
R402002804	RTC-HD, RTC-CG, CKP	M = medium	Ø 16 mm
R402003618	RTC-HD, RTC-CG, CKP	H = hard	Ø 16 mm
R402002805	RTC-HD, RTC-CG, CKP	S = soft	Ø 25 mm, Ø 32 mm, Ø 40
R402003619	RTC-HD, RTC-CG, CKP	M = medium	Ø 25 mm, Ø 32 mm, Ø 40

Dimensions

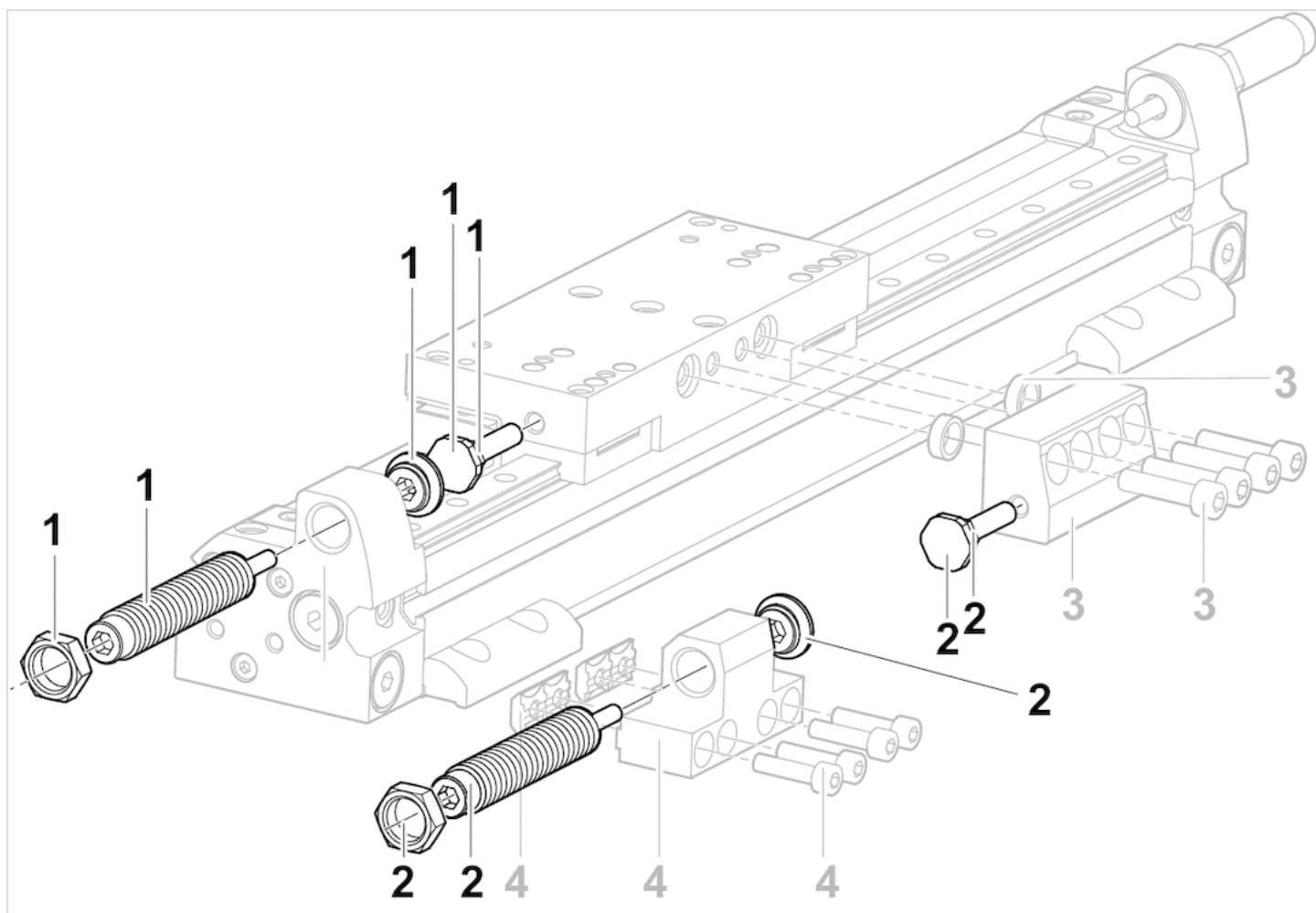

- 1) Shock absorber kit
- 2) Shock absorber kit
- 3) Stop
- 4) Holder for shock absorber

Diagrams

Cushioning diagram, Ø 16 mm

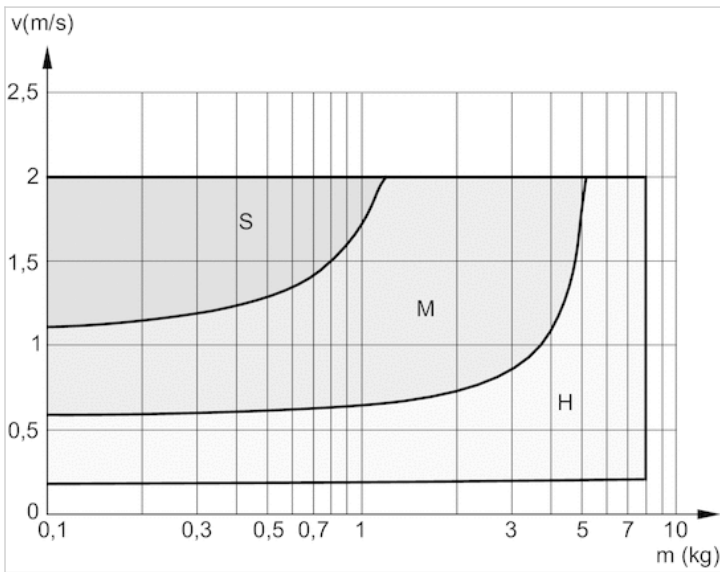

V = velocity [m/s]
 M = moving mass
 S = soft
 M = medium
 H = hard

Cushioning diagram, Ø 25 mm

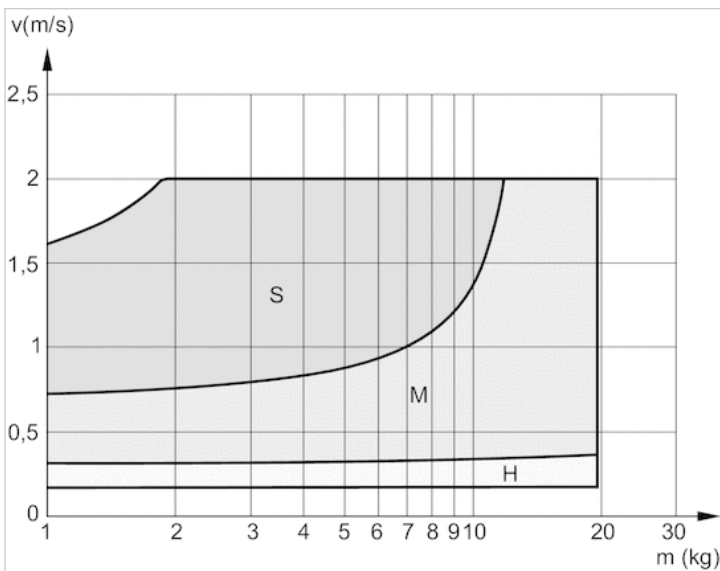

V = velocity [m/s]
 M = moving mass
 S = soft
 M = medium
 H = hard

Cushioning diagram, Ø 32 mm

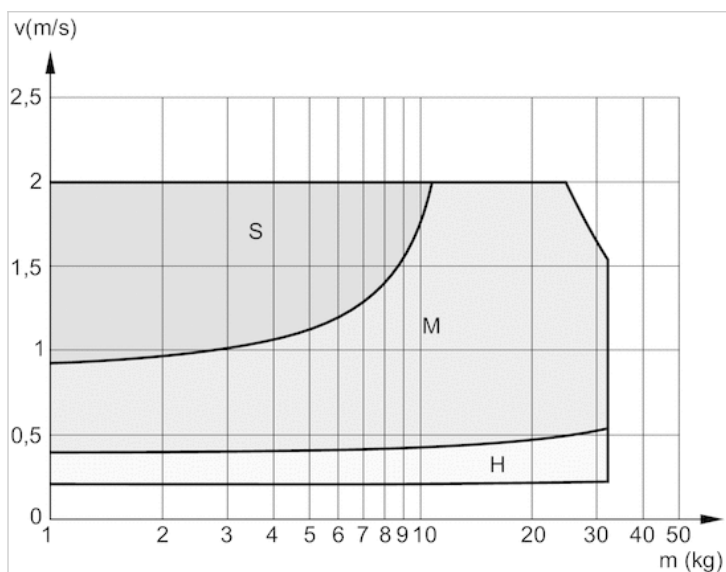

V = velocity [m/s]
 M = moving mass
 S = soft
 M = medium
 H = hard

Cushioning diagram, Ø 40 mm

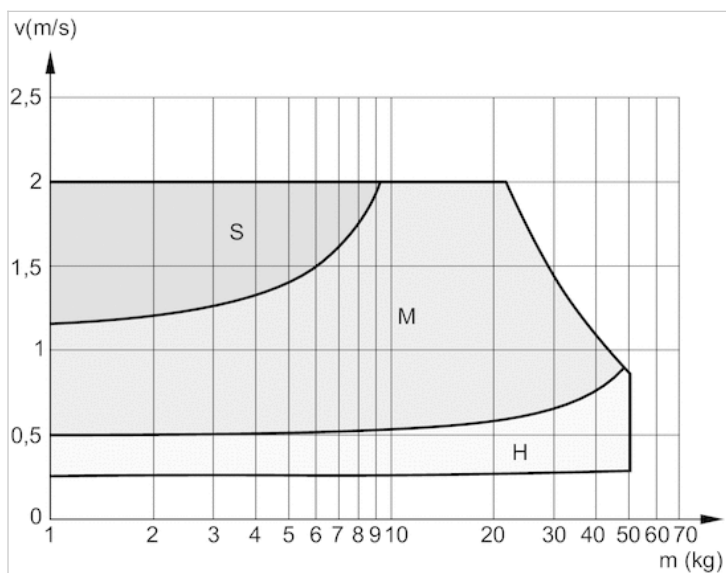

V = velocity [m/s]
 M = moving mass
 S = soft
 M = medium
 H = hard

Cushioning diagram, Ø 50 mm

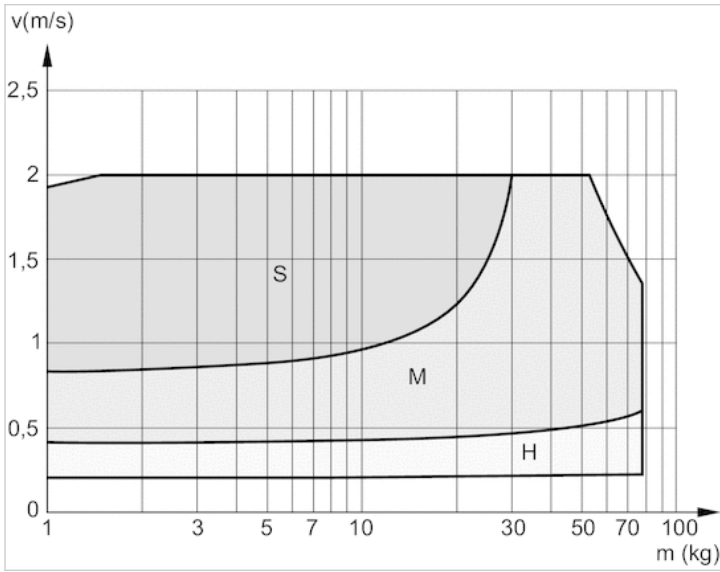

V = velocity [m/s]
 M = moving mass
 S = soft
 M = medium
 H = hard

Cushioning diagram, Ø 63 mm

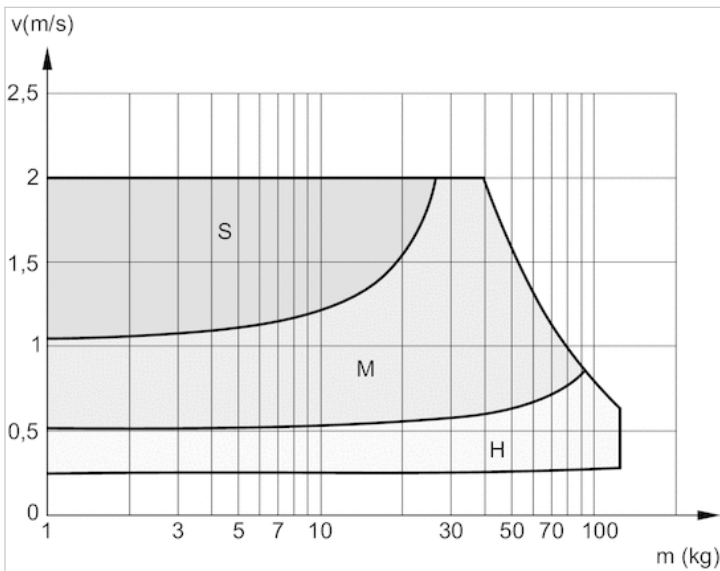

V = velocity [m/s]
 M = moving mass
 S = soft
 M = medium
 H = hard

Stop for stroke length adjustment

- Ø 16 mm Ø 25 mm Ø 32 mm

- for CKP



Technical data

Part No.	for series	Diameter
R402004156	CKP	Ø 16 mm
R402004157	CKP	Ø 25 mm
R402004158	CKP	Ø 32 mm

Dimensions

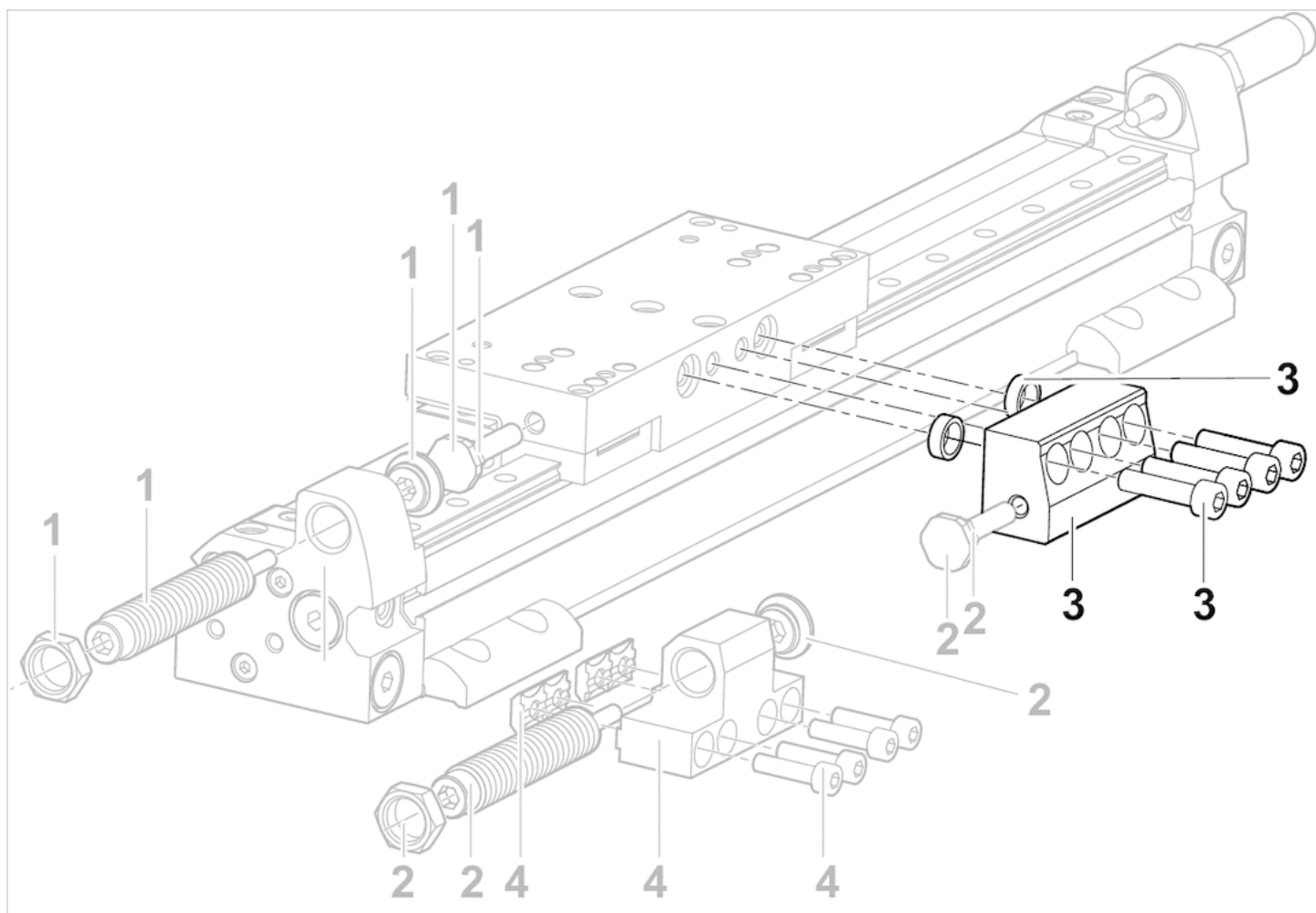

- 1) Shock absorber kit
- 2) Shock absorber kit
- 3) Stop
- 4) Holder for shock absorber

Holder for the shock absorber for stroke length adjustment

- Ø 16 mm Ø 25 mm Ø 32 mm, Ø 40 mm

- for RTC-HD, RTC-CG, CKP



Technical data

Part No.	for series	Diameter
R402002702	RTC-HD, RTC-CG, CKP	Ø 16 mm
R402002703	RTC-HD, RTC-CG, CKP	Ø 25 mm
R402002704	RTC-HD, RTC-CG, CKP	Ø 32 mm, Ø 40 mm

Dimensions

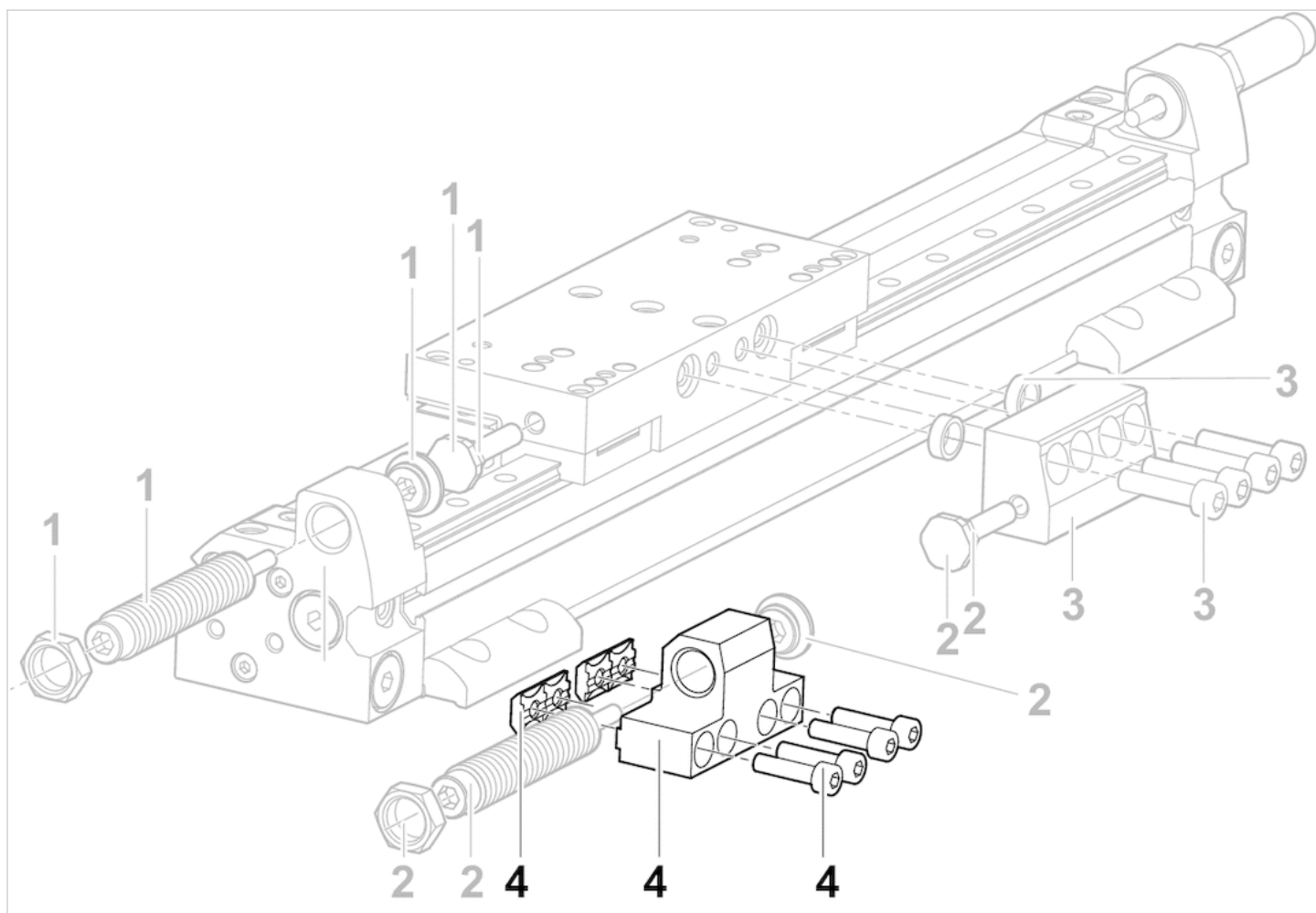

- 1) Shock absorber kit
- 2) Shock absorber kit
- 3) Stop
- 4) Holder for shock absorber

Kit for intermediate position

- for RTC-CG, RTC-HD, CKP
- double-acting
- with magnetic piston



Weight

0.87 kg

Technical data

Part No.

R412024700

for RTC-CG (25, 32, 40 mm), RTC-HD (25, 32, 40 mm), CKP

Technical information

The volume per stroke is 4.6 cm³.
 Returning from the stop position is only permissible when not under power.
 The stopper must not be operated without a shock absorber.

Dimensions

Overview drawing

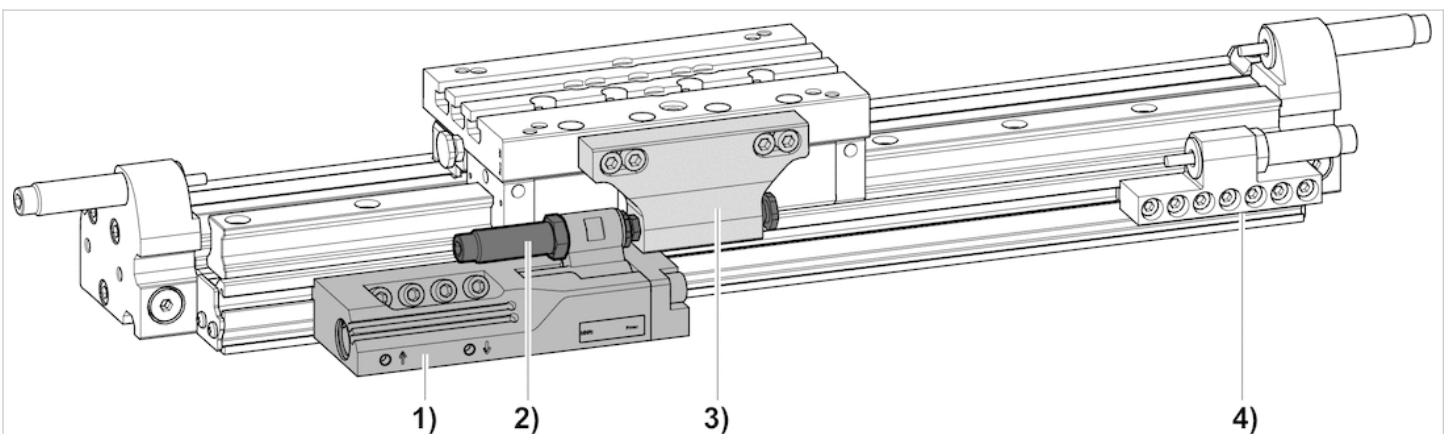

- 1) Intermediate stop
- 2) Shock absorber kit

- 3) Stop
- 4) Holder for the shock absorber: see stroke length adjustment kit for details

Dimensions

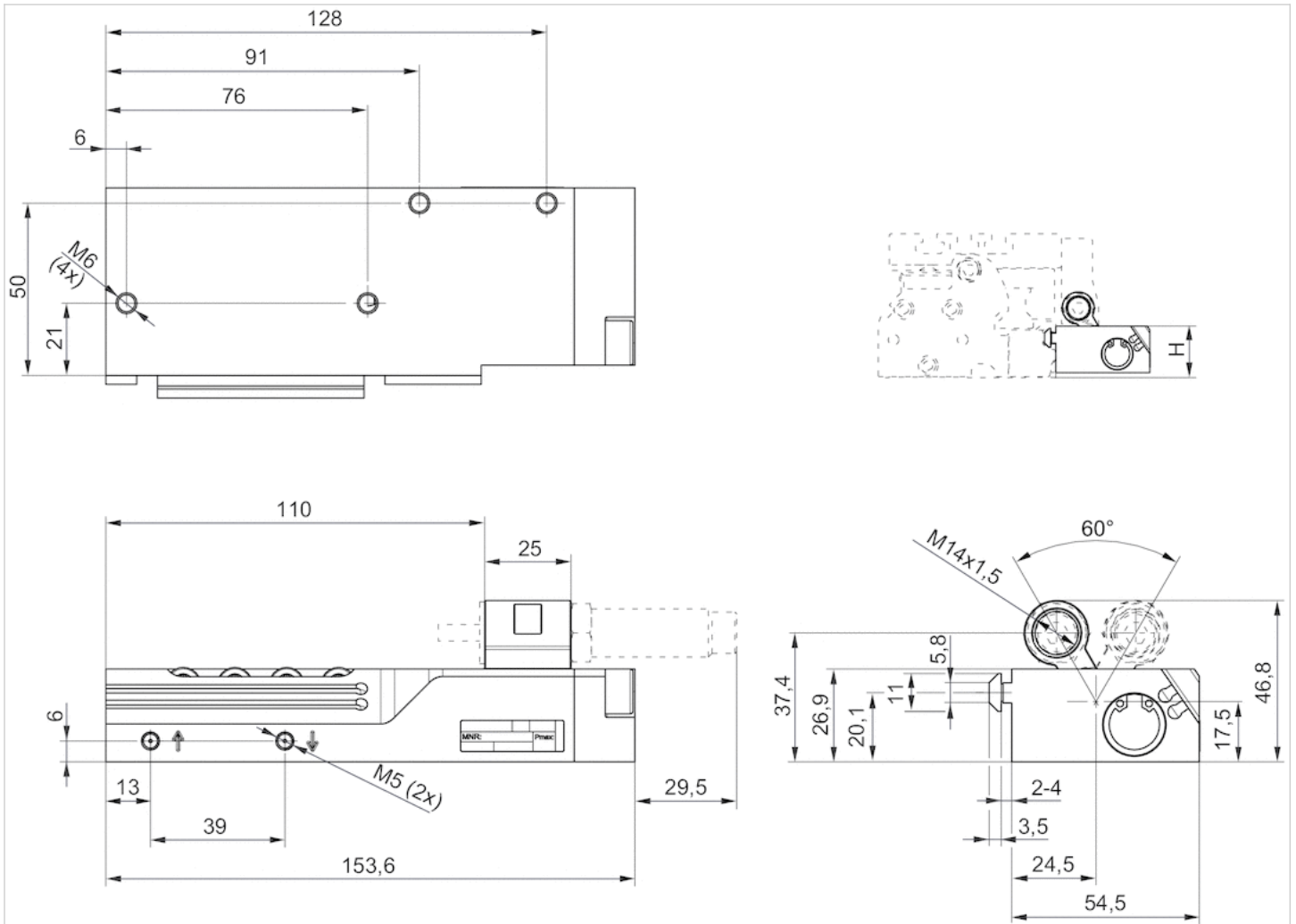

Direction of travel: left, Stopper position A restricted

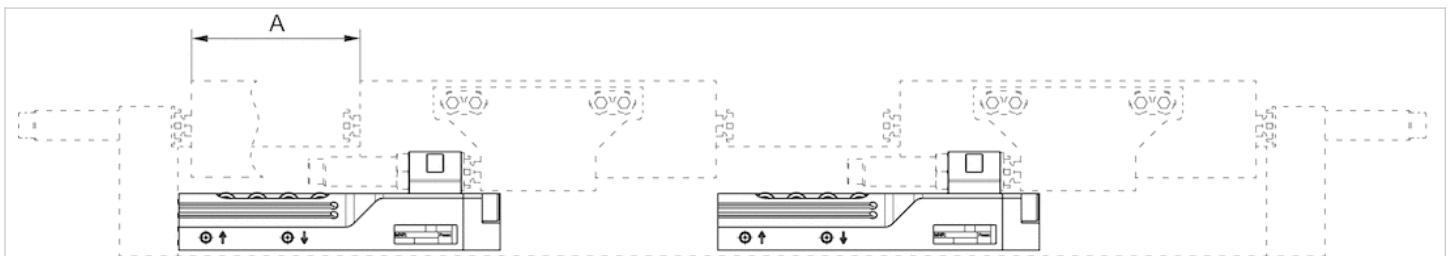

Direction of travel: right, No restriction of the stopper position



Multiple installation, Minimum stopper distance B

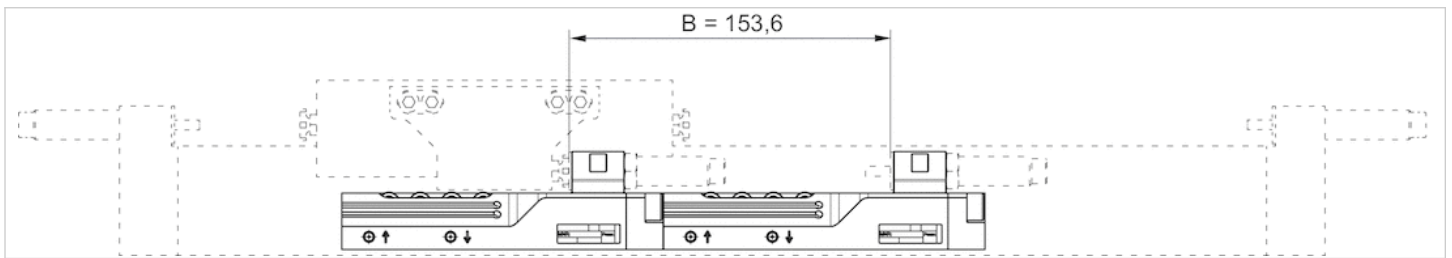

Dimensions

	RTC-CG25	RTC-CG32	RTC-CG40	RTC-HD25	RTC-HD32	RTC-HD40
A	92,5	80	79,5	92,5	80	79,5
H	33,5	38,5	48,5	27	30	31,5

Sensor, Series ST4

- 4 mm T-slot
- with cable
- Plug, M8, 3-pin, with knurled screw
- UL certification
- Reed electronic PNP
- Direct mounting for series PRA, SSI, GSU, RTC, CKP, GPC, MSC, MSN, RCM, CVI
- Indirect mounting for series MNI, CSL-RD, ICM



Certificates	UL (Underwriters Laboratories) cULus RoHS
Ambient temperature min./max.	-30 ... 80 °C
Protection class	IP65, IP67
Switching point precision	±0,1 mT
Min./max. DC operating voltage	See table below
Switching logic	NO (make contact)
Display	LED
LED status display	Yellow
Vibration resistance	10 - 55 Hz, 1 mm
Shock resistance	30 g / 11 ms
Cable length L	0.3 0.5 m
Mounting screw	Combination: slotted and hexagon socket

Technical data

Part No.		for
R412019490		PRA, SSI, GSU, RTC, CKP, GPC, MSC, MSN, RCM, CVI
R412019686		PRA, SSI, GSU, RTC, CKP, GPC, MSC, MSN, RCM, CVI
R412019493		PRA, SSI, GSU, RTC, CKP, GPC, MSC, MSN, RCM, CVI
R412019687		PRA, SSI, GSU, RTC, CKP, GPC, MSC, MSN, RCM, CVI

Part No.	Type of contact	Cable length L	Min./max. DC operating voltage
R412019490	Reed	0.3 m	5 ... 30 V DC
R412019686	Reed	0.5 m	5 ... 30 V DC
R412019493	electronic PNP	0.3 m	10 ... 30 V DC
R412019687	electronic PNP	0.5 m	10 ... 30 V DC

Part No.	Voltage drop U at I _{max}	DC switching current, max.
R412019490	≤ 0,5 V	0.13 A
R412019686	≤ 0,5 V	0.13 A
R412019493	≤ 2,5 V	0.1 A
R412019687	≤ 2,5 V	0.1 A

Part No.	AC switching current, max.	Switching capacity
R412019490	0.13 A	3 W / 3 VA

Part No.	AC switching current, max.	Switching capacity
R412019686	0.13 A	3 W / 3 VA
R412019493	-	-
R412019687	-	-

Part No.	Version
R412019490	Protected against polarity reversal
R412019686	Protected against polarity reversal
R412019493	short circuit resistant Protected against polarity reversal
R412019687	short circuit resistant Protected against polarity reversal

Technical information

The max. switching capacity must not be exceeded.

Technical information

Material	
Housing	Polyamide fiber-glass reinforced
Cable sheath	Polyurethane

Dimensions

Dimensions

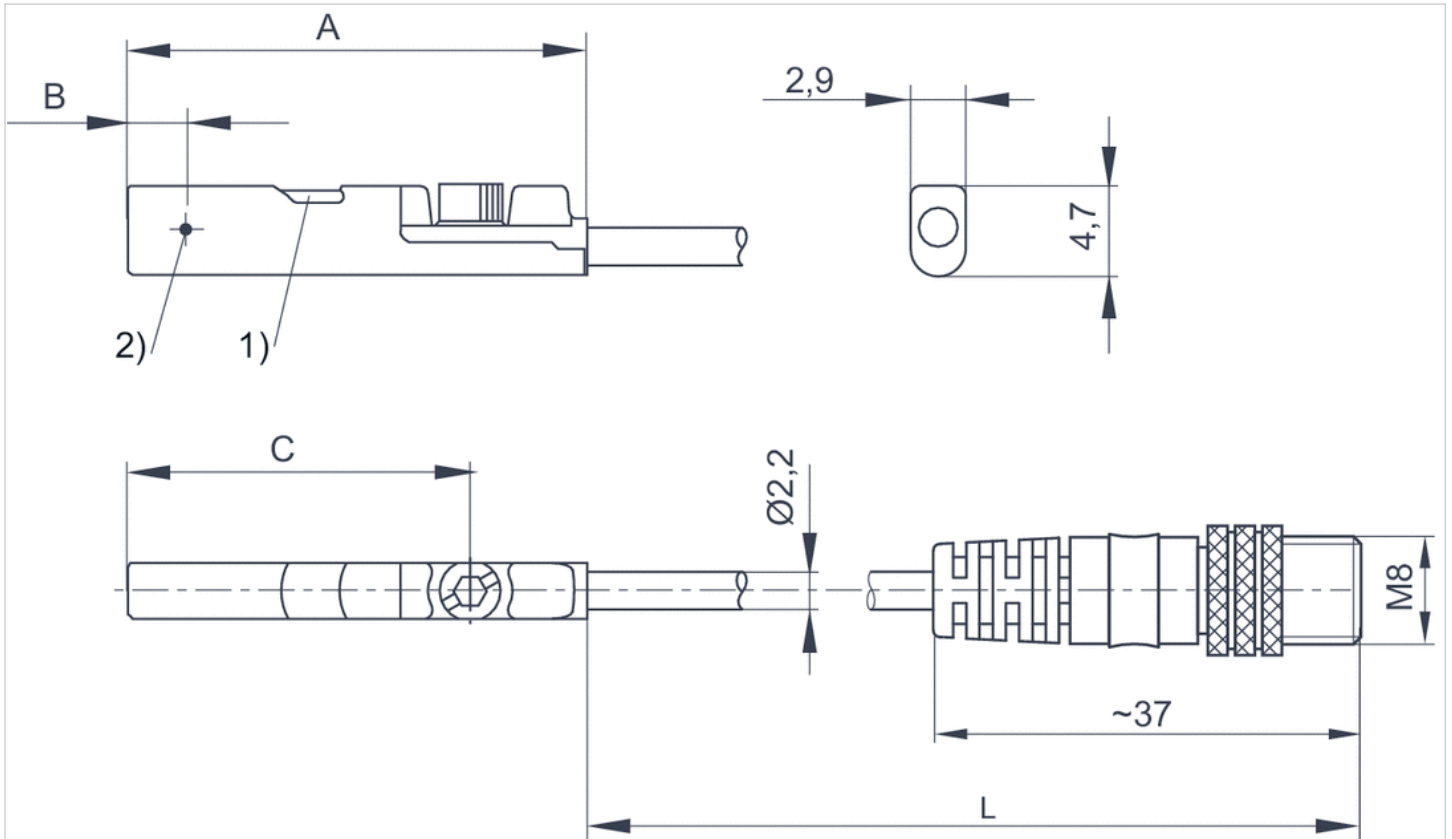

1) LED 2) Switching point
L = cable length

Dimensions

Part No.	A	B	C
R412019490	26.3	6.3	20.3
R412019686	26.3	6.3	20.3
R412019493	23.7	2.8	17.7
R412019687	23.7	2.8	17.7

Pin assignments

Pin assignments

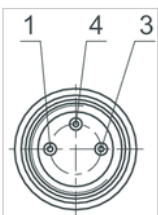

Pin	1	3	4
Allocation	(+)	(-)	(OUT)

Sensor, Series ST4

- 4 mm T-slot
- with cable
- Plug, M8, 3-pin
- UL certification
- Reed electronic PNP electronic NPN
- Direct mounting for series PRA, SSI, GSU, RTC, CKP, GSP, MSC, MSN, RCM, CVI
- Indirect mounting for series MNI, CSL-RD, ICM



Certificates	UL (Underwriters Laboratories) cULus RoHS
Ambient temperature min./max.	-30 ... 80 °C
Protection class	IP65, IP67
Switching point precision	±0,1 mT
Min./max. DC operating voltage	See table below
Switching logic	NO (make contact)
Display	LED
LED status display	Yellow
Vibration resistance	10 - 55 Hz, 1 mm
Shock resistance	30 g / 11 ms
Cable length L	0.3 m
Mounting screw	Combination: slotted and hexagon socket

Technical data

Part No.		for
R412019682		PRA, SSI, GSU, RTC, CKP, GSP, MSC, MSN, RCM, CVI
R412019683		PRA, SSI, GSU, RTC, CKP, GSP, MSC, MSN, RCM, CVI
R412019694		PRA, SSI, GSU, RTC, CKP, GSP, MSC, MSN, RCM, CVI

Part No.	Type of contact	Cable length L	Min./max. DC operating voltage
R412019682	Reed	0.3 m	5 ... 30 V DC
R412019683	electronic PNP	0.3 m	10 ... 30 V DC
R412019694	electronic NPN	0.3 m	10 ... 30 V DC

Part No.	Voltage drop U at I _{max}	DC switching current, max.
R412019682	≤ 0,5 V	0.13 A
R412019683	≤ 2,5 V	0.1 A
R412019694	≤ 2,5 V	0.1 A

Part No.	AC switching current, max.	Switching capacity
R412019682	0.13 A	3 W / 3 VA
R412019683	-	-
R412019694	-	-

Part No.	Version
R412019682	Protected against polarity reversal
R412019683	short circuit resistant Protected against polarity reversal
R412019694	short circuit resistant Protected against polarity reversal

Technical information

The max. switching capacity must not be exceeded.

Technical information

Material	
Housing	Polyamide fiber-glass reinforced
Cable sheath	Polyurethane

Dimensions

Dimensions

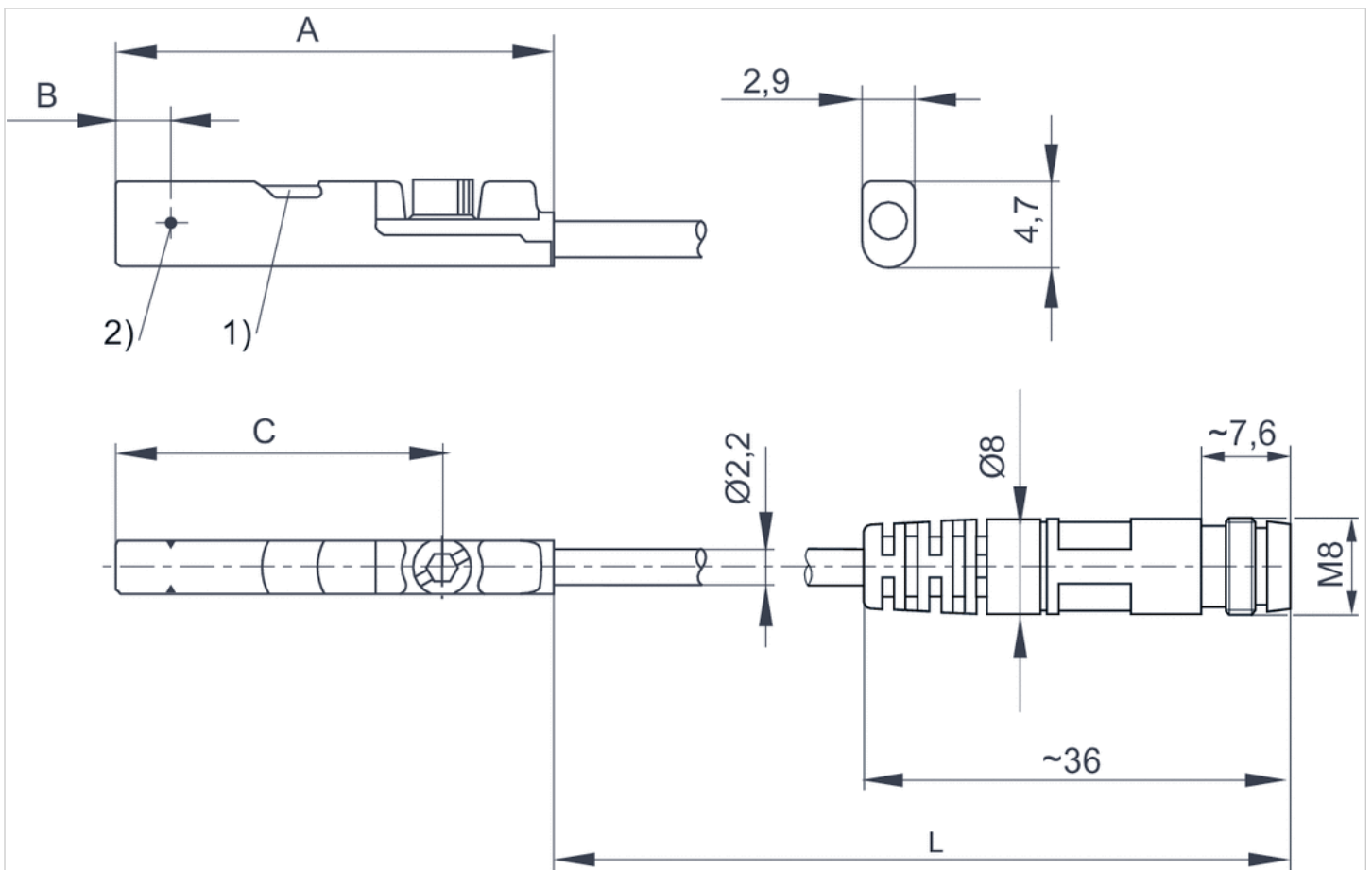

1) LED 2) Switching point
L = cable length

Dimensions

Part No.	A	B	C
R412019682	26.3	6.3	20.3
R412019683	23.7	2.8	17.7
R412019694	23.7	2.8	17.7

Pin assignments

Pin assignments

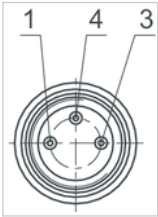

Pin	1	3	4
Allocation	(+)	(-)	(OUT)

Sensor, Series ST4

- 4 mm T-slot
- with cable
- open cable ends, 3-pin
- UL certification
- Reed electronic PNP electronic NPN
- Direct mounting for series PRA, SSI, GSU, RTC, CKP, GPC, MSC, MSN, RCM, CVI
- Indirect mounting for series MNI, CSL-RD, ICM



Certificates	UL (Underwriters Laboratories) cULus RoHS
Ambient temperature min./max.	-30 ... 80 °C
Protection class	IP65, IP67
Switching point precision	±0,1 mT
Min./max. DC operating voltage	See table below
Switching logic	NO (make contact)
Display	LED
LED status display	Yellow
Vibration resistance	10 - 55 Hz, 1 mm
Shock resistance	30 g / 11 ms
Cable length L	3 5 m
Mounting screw	Combination: slotted and hexagon socket

Technical data

Part No.		for
R412019488		PRA, SSI, GSU, RTC, CKP, GPC, MSC, MSN, RCM, CVI
R412019489		PRA, SSI, GSU, RTC, CKP, GPC, MSC, MSN, RCM, CVI
R412019680		PRA, SSI, GSU, RTC, CKP, GPC, MSC, MSN, RCM, CVI
R412019681		PRA, SSI, GSU, RTC, CKP, GPC, MSC, MSN, RCM, CVI
R412019684		PRA, SSI, GSU, RTC, CKP, GPC, MSC, MSN, RCM, CVI
R412019685		PRA, SSI, GSU, RTC, CKP, GPC, MSC, MSN, RCM, CVI

Part No.	Type of contact	Cable length L	Min./max. DC operating voltage
R412019488	Reed	3 m	5 ... 30 V DC
R412019489	Reed	5 m	5 ... 30 V DC
R412019680	electronic PNP	3 m	10 ... 30 V DC
R412019681	electronic PNP	5 m	10 ... 30 V DC
R412019684	electronic NPN	3 m	10 ... 30 V DC
R412019685	electronic NPN	5 m	10 ... 30 V DC

Part No.	Voltage drop U at I _{max}	DC switching current, max.
R412019488	≤ 0,5 V	0.13 A
R412019489	≤ 0,5 V	0.13 A
R412019680	≤ 2,5 V	0.1 A
R412019681	≤ 2,5 V	0.1 A

Part No.	Voltage drop U at I _{max}	DC switching current, max.
R412019684	≤ 2,5 V	0.1 A
R412019685	≤ 2,5 V	0.1 A

Part No.	AC switching current, max.	Switching capacity
R412019488	0.13 A	3 W / 3 VA
R412019489	0.13 A	3 W / 3 VA
R412019680	-	-
R412019681	-	-
R412019684	-	-
R412019685	-	-

Part No.	Version
R412019488	Protected against polarity reversal
R412019489	Protected against polarity reversal
R412019680	short circuit resistant Protected against polarity reversal
R412019681	short circuit resistant Protected against polarity reversal
R412019684	short circuit resistant Protected against polarity reversal
R412019685	short circuit resistant Protected against polarity reversal

Technical information

The max. switching capacity must not be exceeded.

Technical information

Material	
Housing	Polyamide fiber-glass reinforced
Cable sheath	Polyurethane

Dimensions

Dimensions

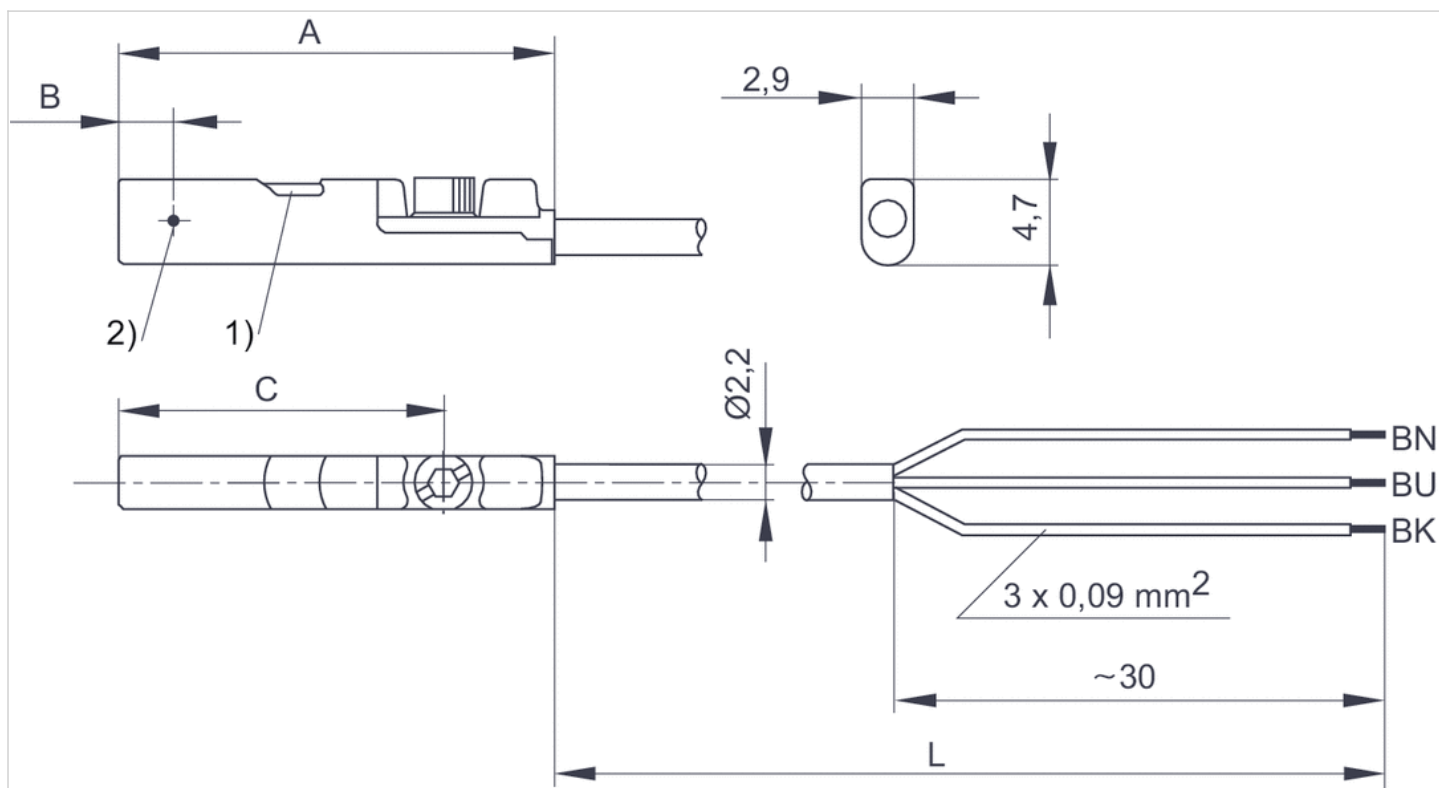

1) LED 2) Switching point

L = cable length

BN = brown, BK = black, BU = blue

Dimensions

Part No.	A	B	C
R412019488	26.3	6.3	20.3
R412019489	26.3	6.3	20.3
R412019680	23.7	2.8	17.7
R412019681	23.7	2.8	17.7
R412019684	23.7	2.8	17.7
R412019685	23.7	2.8	17.7

Sensor mounting, Series ST4

- for series ST4

- to mount on cylinder CKP



Weight

0.034 kg

Technical data

Part No.	for series
R402004226	ST4
R402004227	ST4

Technical information

Note that Serie CKP are normally delivered with 2 pairs of sensor holders.

Technical information

Material
Aluminum

Dimensions

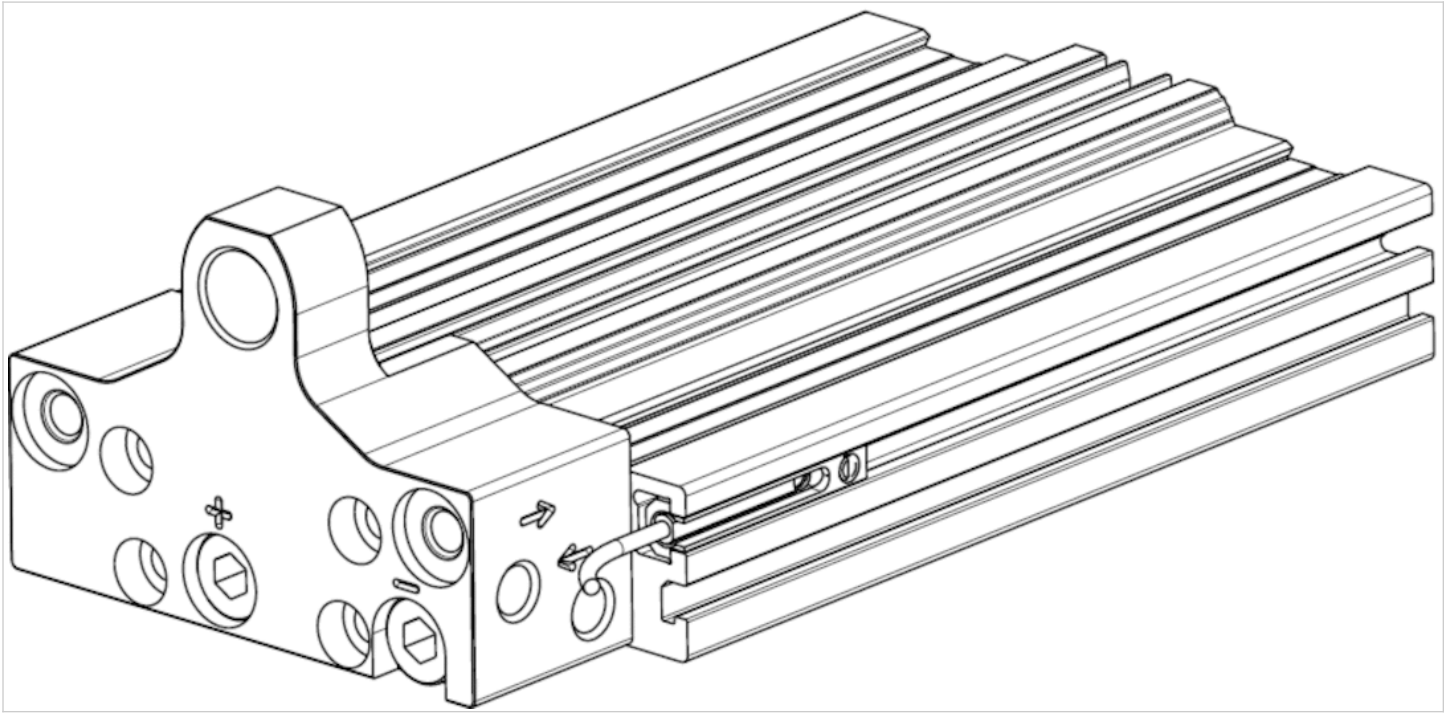

T-groove nut

- for series CKP, GPC, RTC



Weight

See table below

Technical data

Part No.	Type	for series	Material	Scope of delivery	Weight
3842523142	N6	CKP, GPC, RTC	Stainless steel	10 piece	0.003 kg
3842514931	N8	CKP, GPC, RTC	Steel	100 piece	0.007 kg

Technical information

Material	
Housing	Stainless steel Steel, galvanized

Dimensions

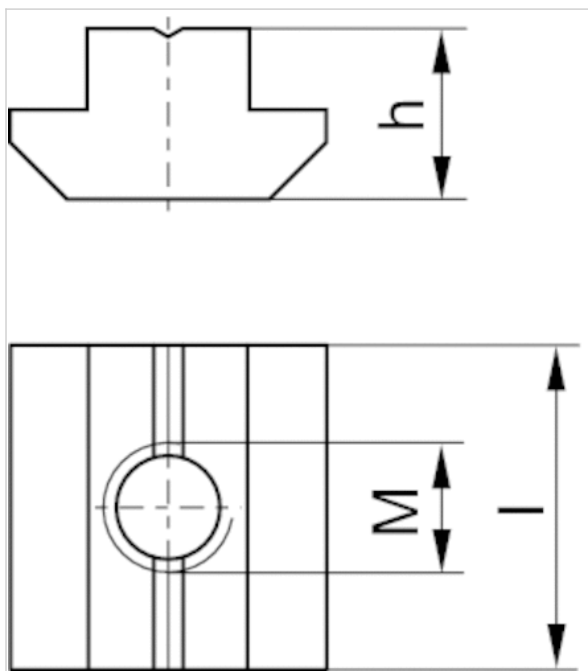

Dimensions

Part No.	Type	M	h	l
3842523142	N6	M5	4	20
3842514931	N8	M8	6	16

For N4 grooves on CKP 16 a square nut according to DIN 557 can be used.

Round plug connector, Series CON-RD

- Socket M8x1 3-pin A-coded straight 180°
- open cable ends
- with cable
- unshielded



Operational voltage	30 / 36 V AC/DC
Protection class	IP67
Wire cross-section	0.34 mm ²
Weight	See table below

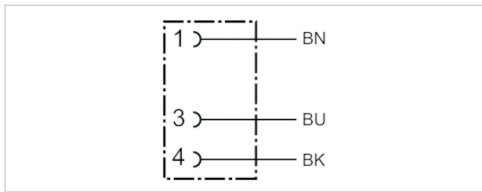

Technical data

Part No.	Max. current	Number of wires	Cable-Ø	Cable length	Weight
8946201312	2.5 A	3	3.5 mm	2 m	0.066 kg
8946201332	2.5 A	3	3.5 mm	15 m	0.466 kg

Technical information

The specified protection class is only valid in assembled and tested state.

Technical information

Material	
Cable sheath	Polyvinyl chloride

Dimensions

Dimensions

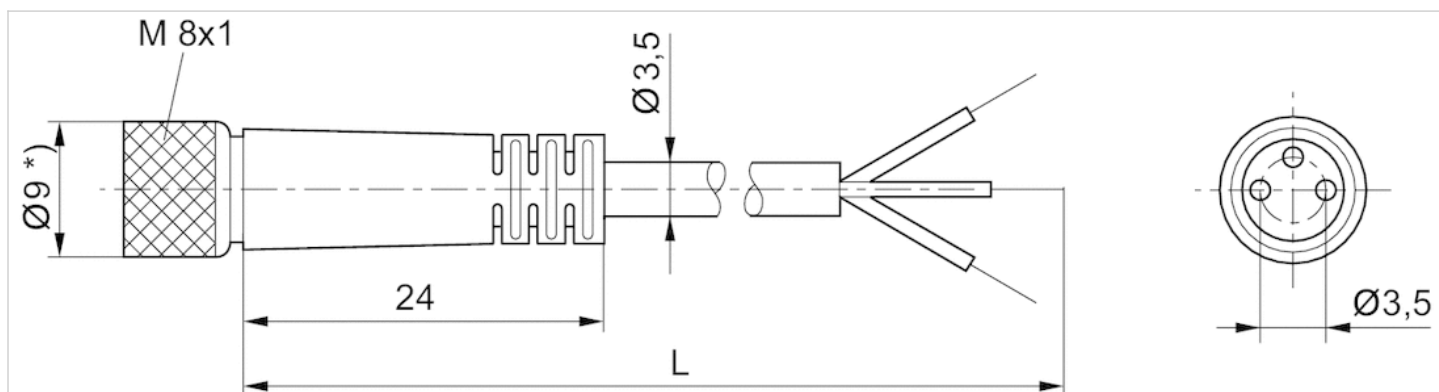

L = length

*) With 15 m cable length $\varnothing 12$

Pin assignments

Pin assignment, socket

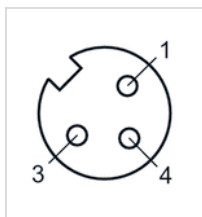

(1) BN=brown

(3) BU=blue

(4) BK=black

Round plug connector, Series CON-RD

- Socket Snap Ø8 3-pin with detent straight 180°
- open cable ends
- with cable
- unshielded



Operational voltage	48 V AC/DC
Protection class	IP65
Wire cross-section	0.25 mm ²
Weight	0.058 kg

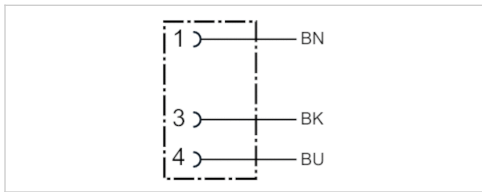

Technical data

Part No.	Max. current	Number of wires	Cable-Ø	Cable length
8946016112	3 A	3	4.5 mm	2.5 m

Technical information

The specified protection class is only valid in assembled and tested state.

Technical information

Material	
Cable sheath	Polyvinyl chloride

Dimensions

Dimensions

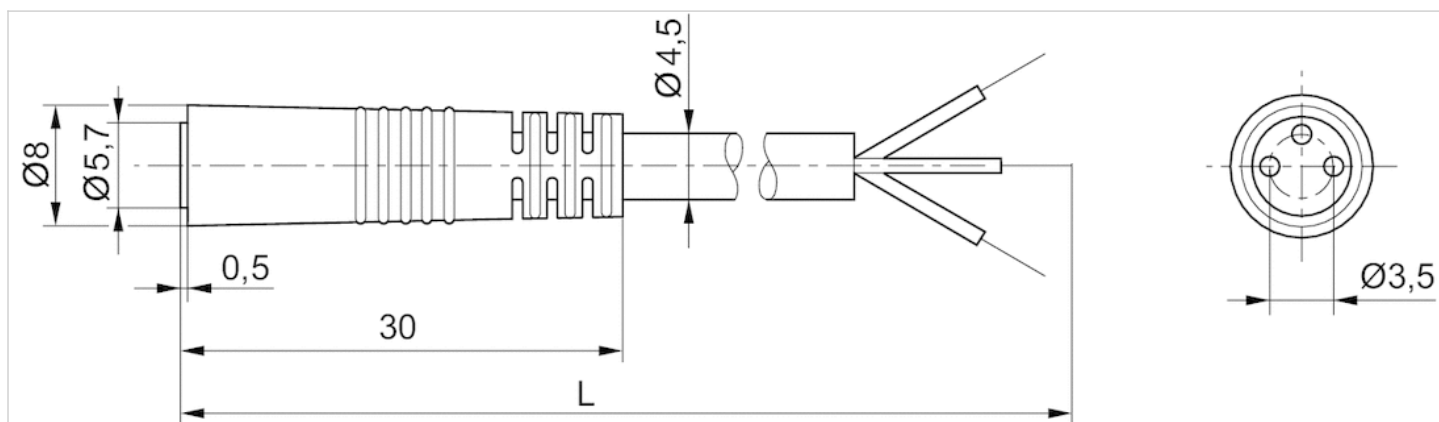

L = length

Pin assignments

Pin assignment, socket

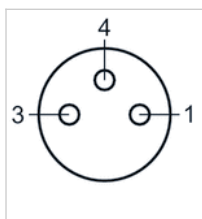

- (1) BN=brown
- (2) BK=black
- (3) BU=blue

Efficient pneumatic solutions, our program: cylinders and drives, valves and valve systems, air supply management



Visit us: [Emerson.com/Aventics](https://www.emerson.com/Aventics)

Your local contact: [Emerson.com/contactus](https://www.emerson.com/contactus)



Emerson.com



[Facebook.com/EmersonAutomationSolutions](https://www.facebook.com/EmersonAutomationSolutions)



[LinkedIn.com/company/Emerson-Automation-Solutions](https://www.linkedin.com/company/Emerson-Automation-Solutions)



[Twitter.com/EMR_Automation](https://twitter.com/EMR_Automation)

An example configuration is depicted on the title page. The delivered product may thus vary from that in the illustration. Subject to change. This Document, as well as the data, specifications and other information set forth in it, are the exclusive property of AVENTICS GmbH. It may not be reproduced or given to third parties without its consent. Only use the AVENTICS products shown in industrial applications. Read the product documentation completely and carefully before using the product. Observe the applicable regulations and laws of the respective country. When integrating the product into applications, note the system manufacturer's specifications for safe use of the product. The data specified only serve to describe the product. No statements concerning a certain condition or suitability for a certain application can be derived from our information. The information given does not release the user from the obligation of own judgment and verification. It must be remembered that the products are subject to a natural process of wear and aging.

The Emerson logo is a trademark and service mark of Emerson Electric Co. Brand logotype are registered trademarks of one of the Emerson family of companies. All other marks are the property of their respective owners. © 2017 Emerson Electric Co. All rights reserved.
2019-03



CONSIDER IT SOLVED™