

Series HF04

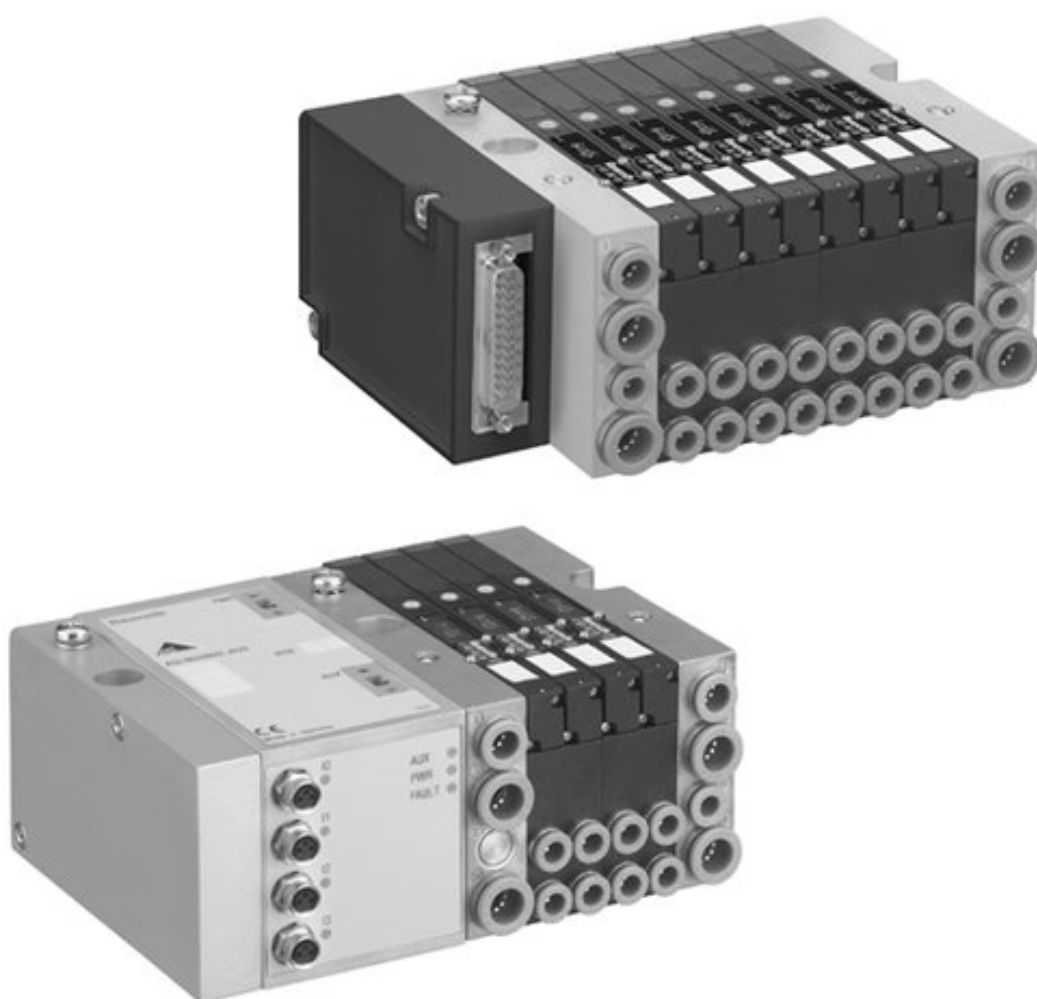

AVENTICS™ Series HF04



Valve system, Series HF04

- Configurable valve systems, Multipole Fieldbus



Blocking principle	Double base plate principle
Working pressure min./max.	-0.9 ... 10 bar
Control pressure min./max.	3 ... 8 bar
Ambient temperature min./max.	-5 ... 50 °C
Medium temperature min./max.	0 ... 50 °C
Medium	Compressed air
Max. particle size	5 µm
Oil content of compressed air	0 ... 5 mg/m ³
Nominal flow Qn	400 l/min
Number of valve positions max.	24
Number of solenoid coils max.	24
Protection class with connection	IP65
DC operating voltage	24 V
Voltage tolerance DC	-10% / +10%

An example configuration is illustrated. The delivered product may thus deviate from the illustration.

Overview of variants

	Version	You have the following options:
	Multipole	D-Sub plug, 25-pin, on the side D-Sub plug, 44-pin, on the side
	Direct fieldbus connection	PROFIBUS DP CANopen DeviceNet PROFINET IO EtherCAT EtherNET/IP EtherNET/IP POWERLINK
	Fieldbus connection with AS i	4 outputs 8 outputs 4 inputs / 4 outputs 8 inputs / 8 outputs
	Fieldbus connection with I/O functionality (CMS)	PROFIBUS DP CANopen DeviceNet EtherNET/IP PROFINET IO
	Connection with diagnosis, optionally with I/O function (DDL)	PROFIBUS DP Interbus-S DeviceNet PROFINET IO
	Connection with diagnosis (DDL)	PROFIBUS DP Interbus-S DeviceNet PROFINET IO

Technical information

The min. control pressure must be adhered to, since otherwise faulty switching and valve failure may result!

The pressure dew point must be at least 15 °C under ambient and medium temperature and may not exceed 3 °C .

The oil content of compressed air must remain constant during the life cycle.

Use only the approved oils from AVENTICS. Further information can be found in the "Technical information" document (available in the MediaCentre).

See the following pages on the series for technical data on individual components.

For push-in fittings, only use plug accessories made of plastic (polyamide) from our catalog.

It is necessary to maintain the electrical current in the coil of double solenoid valves to avoid unexpected auto-switching.

Technical information

Material	
End plate	Aluminum
Plug box	Polyamide
Base plate	Polyamide

Dimensions

Dimensions in mm, D-Sub plug, 25-pin, on the side

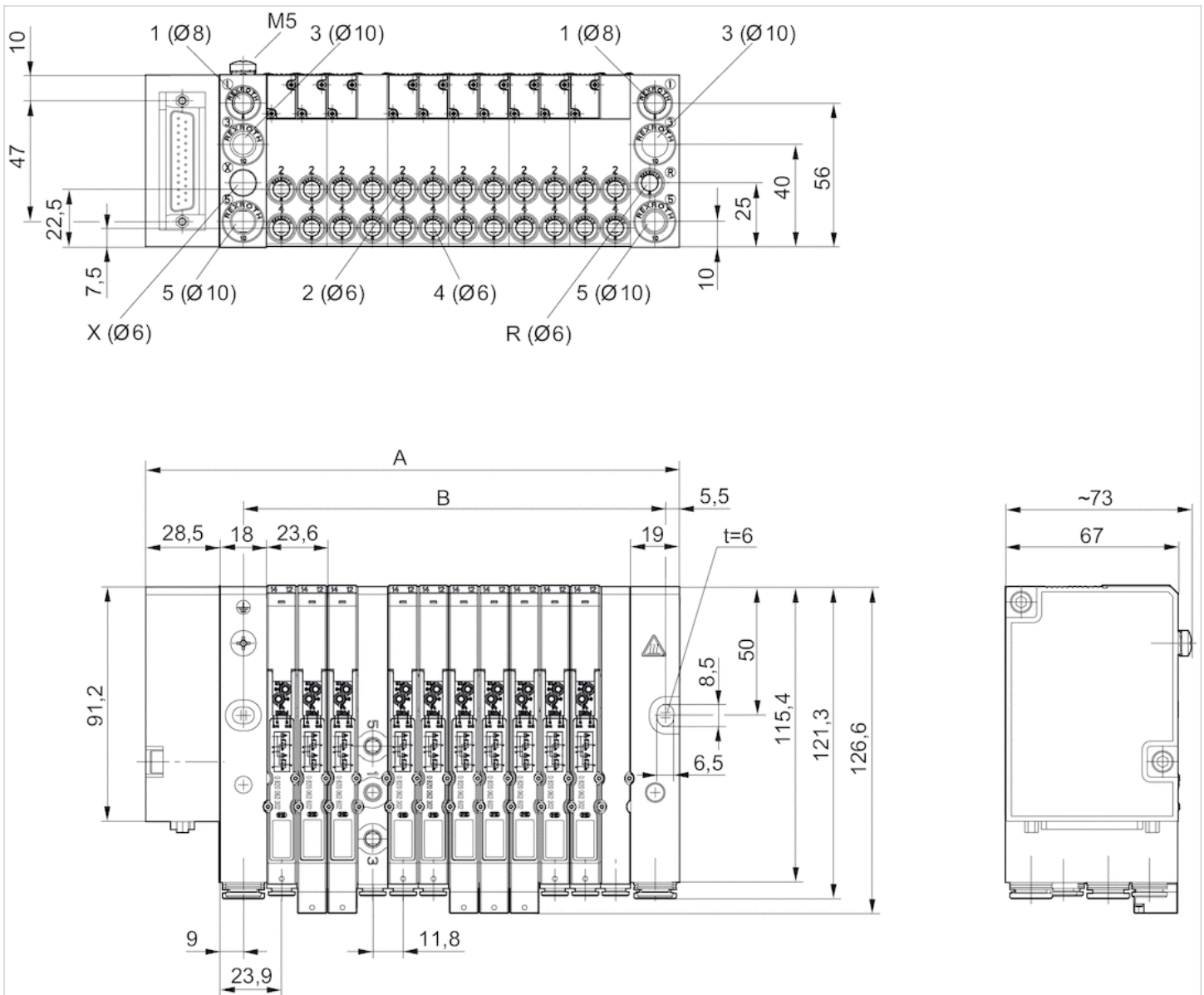

1 = plug-in connection Ø 8 mm or plug-in connection 3/8" (inch)
 2 and 4 = plug-in connections Ø 6 mm or thread connections M7(inch)
 3 and 5 = plug-in connections Ø 10 mm or plug-in connections 3/8" (inch)
 R = collected pilot exhaust, plug-in connection Ø 6 mm or plug-in connection 1/4" (inch)
 X = external pilot, plug-in connection Ø 6 mm or plug-in connection 1/4" (inch), connection X plugged with internal pilot control
 An example configuration is illustrated. The delivered product may thus deviate from the illustration.

Dimensions

n	A	A
1	60.6	60.6
2	84.2	84.2
3	107.8	107.8
4	131.4	131.4
5	155	155

n	A	A
6	178.6	178.6
7	202	202
8	225.8	225.8
9	249.4	249.4
10	273	273
11	296.6	296.6
12	320	320

n = number of double subplates

Dimensions

Dimensions in mm, Direct fieldbus connection

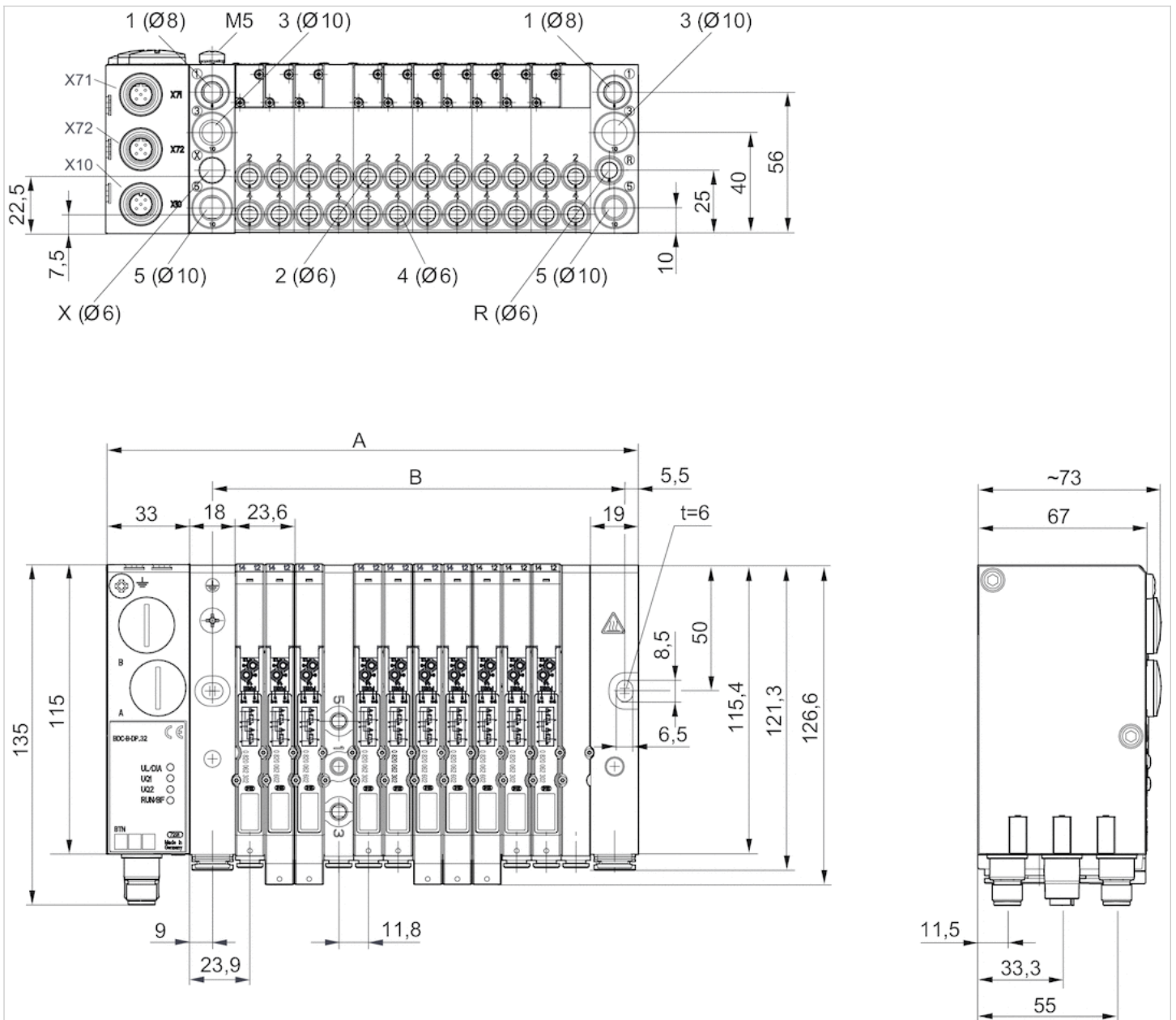

- 1 = plug-in connection Ø 8 mm or plug-in connection 3/8" (inch)
- 2 and 4 = plug-in connections Ø 6 mm or thread connections M7(inch)
- 3 and 5 = plug-in connections Ø 10 mm or plug-in connections 3/8" (inch)
- R = collected pilot exhaust, plug-in connection Ø 6 mm or plug-in connection 1/4" (inch)

X = external pilot, plug-in connection Ø 6 mm or plug-in connection 1/4" (inch), connection X plugged with internal pilot control
 An example configuration is illustrated. The delivered product may thus deviate from the illustration.

Dimensions

n	A	B
1	93.6	46.1
2	117.2	69.7
3	140.8	93.3
4	164.4	116.9
5	188	140.5
6	211.6	164.1
7	235.2	187.7
8	258.8	211.3
9	282.4	234.9
10	306	258.5
11	329.6	282.1
12	353.2	305.7

n = number of double subplates

Dimensions

Dimensions in mm, Optional fieldbus connection with I/O function (CMS), B-design

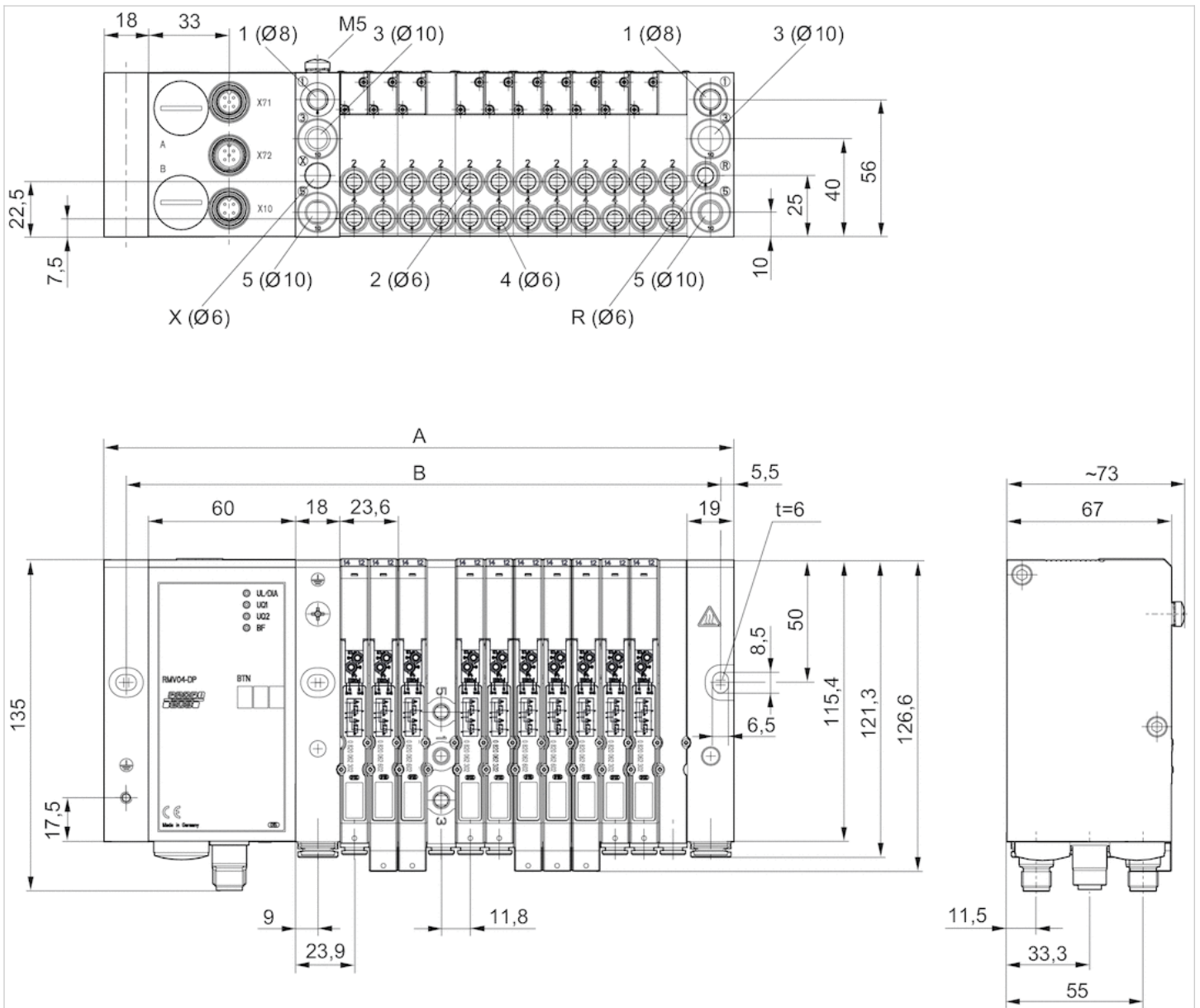

- 1 = plug-in connection Ø 8 mm or plug-in connection 3/8" (inch)
 - 2 and 4 = plug-in connections Ø 6 mm or thread connections M7 (inch)
 - 3 and 5 = plug-in connections Ø 10 mm or plug-in connections 3/8" (inch)
 - R = collected pilot exhaust, plug-in connection Ø 6 mm or plug-in connection 1/4" (inch)
 - X = external pilot, plug-in connection Ø 6 mm or plug-in connection 1/4" (inch), connection X plugged with internal pilot control
- An example configuration is illustrated. The delivered product may thus deviate from the illustration.

Dimensions

n	A	B
1	138.6	124.1
2	162.2	147.7
3	185.8	171.3
4	209.4	194.9
5	233	218.5

n	A	B
6	256.6	242.1
7	280.2	265.7
8	303.8	289.3
9	327.4	312.9
10	351	336.5
11	374.6	360.1
12	398.2	383.7

n = number of double subplates

Dimensions

Dimensions in mm, Connection with diagnosis (DDL)

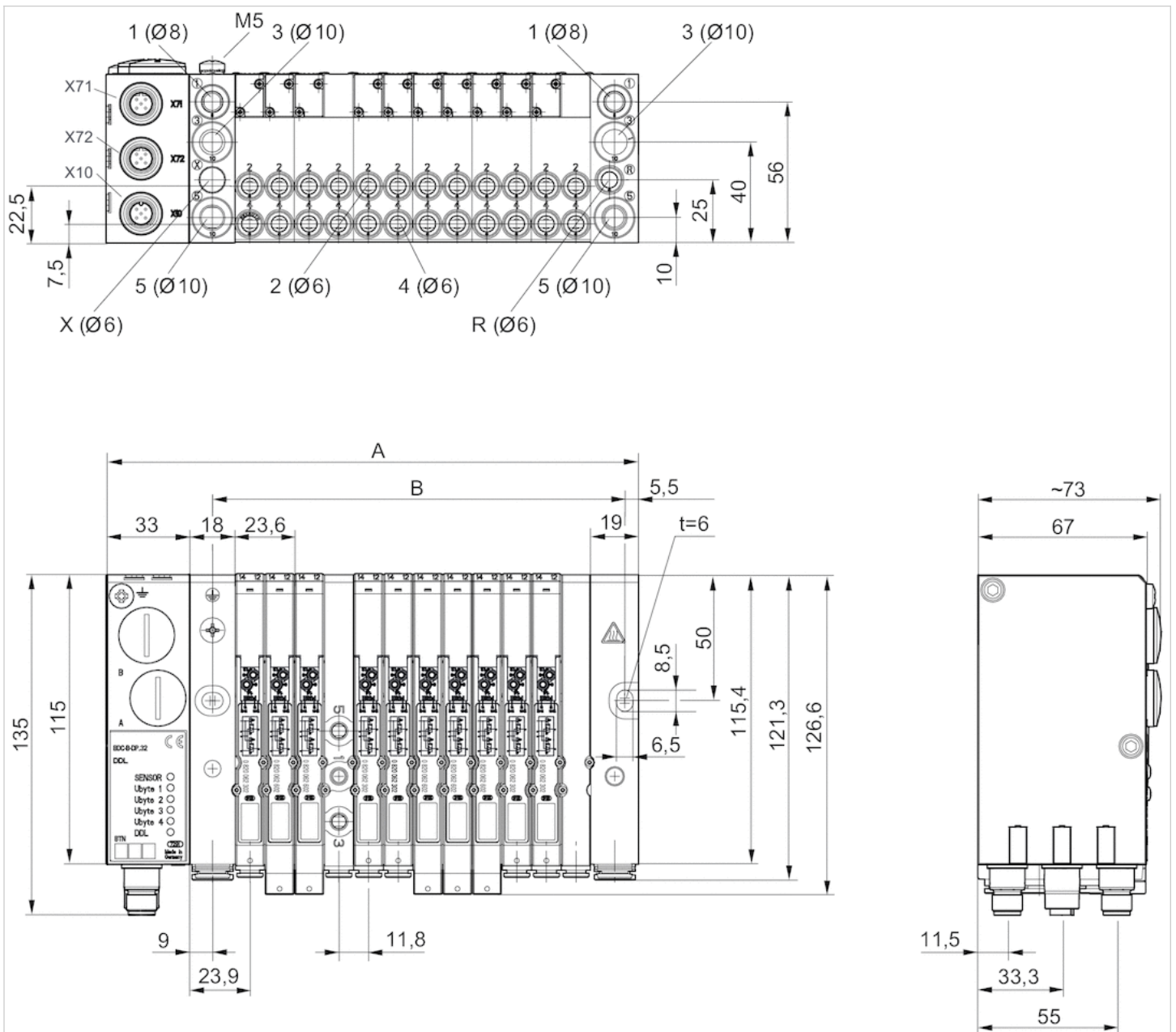

- 1 = plug-in connection Ø 8 mm or plug-in connection 3/8" (inch)
- 2 and 4 = plug-in connections Ø 6 mm or thread connections M7(inch)
- 3 and 5 = plug-in connections Ø 10 mm or plug-in connections 3/8" (inch)

R = collected pilot exhaust, plug-in connection Ø 6 mm or plug-in connection 1/4" (inch)

X = external pilot, plug-in connection Ø 6 mm or plug-in connection 1/4" (inch), connection X plugged with internal pilot control

An example configuration is illustrated. The delivered product may thus deviate from the illustration.

Dimensions

n	A	B
1	93.6	46.1
2	117.2	69.7
3	140.8	93.3
4	164.4	116.9
5	188	140.5
6	211.6	164.1
7	235.2	187.7
8	258.8	211.3
9	282.4	234.9
10	306	258.5
11	329.6	282.1
12	353.2	305.7

n = number of double subplates

Dimensions

Dimensions in mm, Connection with diagnosis, optionally with I/O function (DDL)

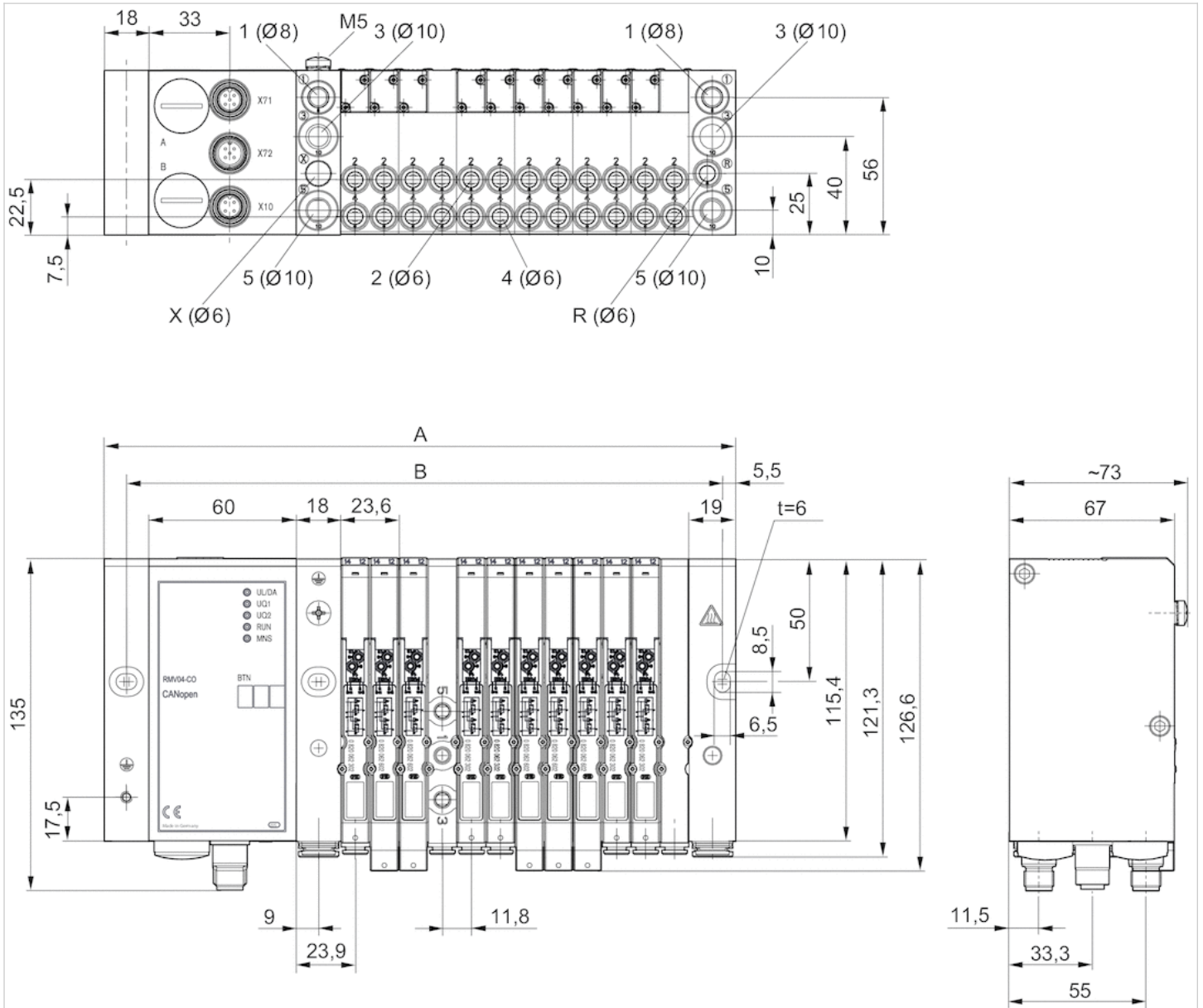

- 1 = plug-in connection Ø 8 mm or plug-in connection 3/8" (inch)
 - 2 and 4 = plug-in connections Ø 6 mm or thread connections M7 (inch)
 - 3 and 5 = plug-in connections Ø 10 mm or plug-in connections 3/8" (inch)
 - R = collected pilot exhaust, plug-in connection Ø 6 mm or plug-in connection 1/4" (inch)
 - X = external pilot, plug-in connection Ø 6 mm or plug-in connection 1/4" (inch), connection X plugged with internal pilot control
- An example configuration is illustrated. The delivered product may thus deviate from the illustration.

Dimensions

n	A	B
1	138.6	124.1
2	162.2	147.7
3	185.8	171.3
4	209.4	194.9
5	233	218.5

n	A	B
6	256.6	242.1
7	280.2	265.7
8	303.8	289.3
9	327.4	312.9
10	351	336.5
11	374.6	360.1
12	398.2	383.7

n = number of double subplates

Dimensions

Dimensions in mm, 8DI/8DO-AUX

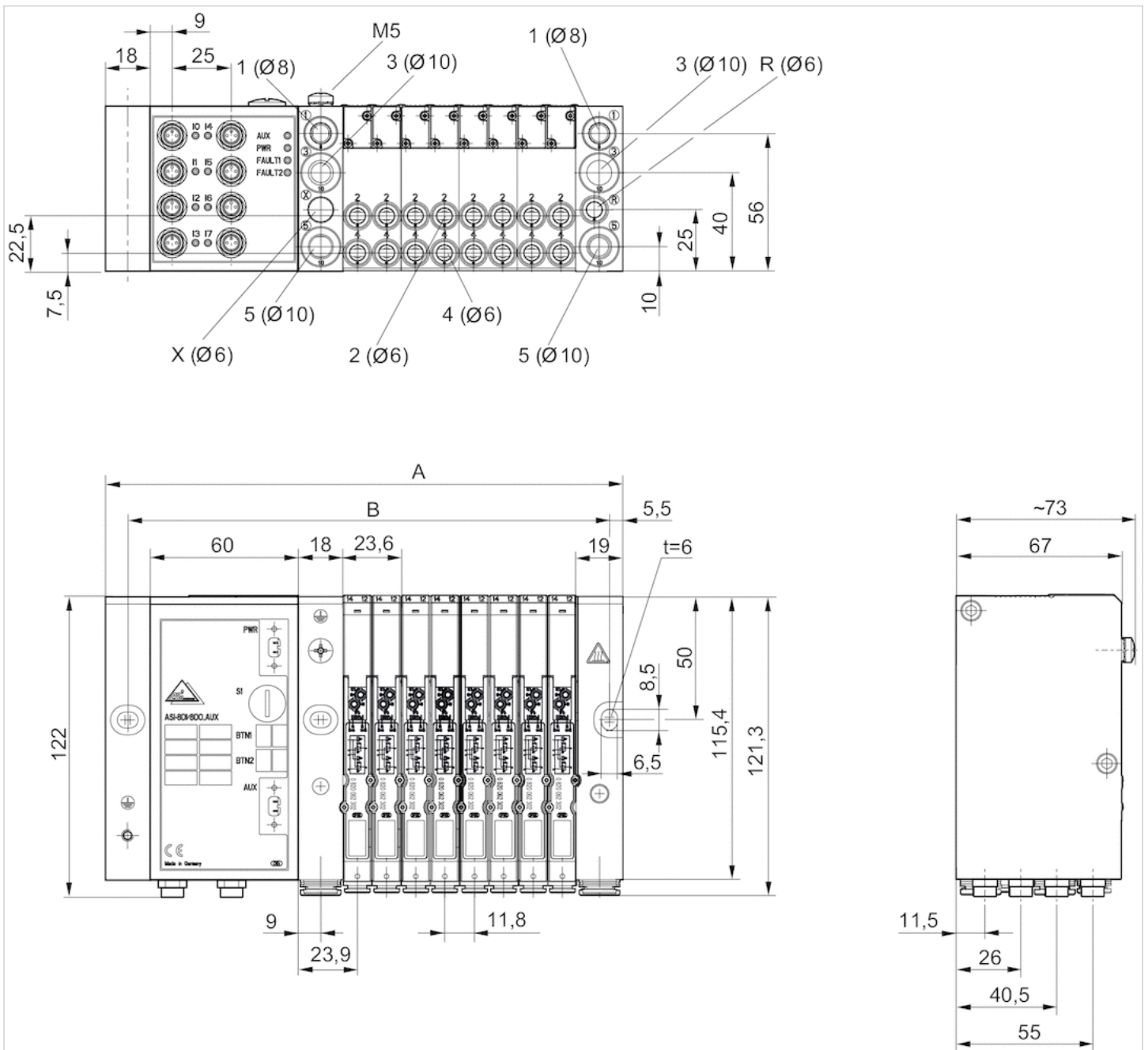

1 = plug-in connection Ø 8 mm or plug-in connection 3/8" (inch)
 2 and 4 = plug-in connections Ø 6 mm or thread connections M7 (inch)

3 and 5 = plug-in connections Ø 10 mm or plug-in connections 3/8" (inch)

R = collected pilot exhaust, plug-in connection Ø 6 mm or plug-in connection 1/4" (inch)

X = external pilot, plug-in connection Ø 6 mm or plug-in connection 1/4" (inch), connection X plugged with internal pilot control

Max. 4 double subbases possible, max. 8 valves

An example configuration is illustrated. The delivered product may thus deviate from the illustration.

Dimensions

n	A	B
1	138.6	124.1
2	162.2	147.7
3	185.8	171.3
4	209.4	194.9

n = number of double subplates







2x3/2-directional valve, Series HF04

- For series : HF04, LP04, HF04-XF
- 2x3/2
- Qn = 400 l/min
- Pilot valve width : 10 mm
- NC/NC NO/NO NC/NO
- Plate connection
- Manual override : with detent
- Pilot : External, Internal



Version	Spool valve, positive overlapping
Activation	Electrically
Pilot	External, Internal
Sealing principle	Soft sealing
Blocking principle	Double base plate principle
Working pressure min./max.	-0.9 ... 10 bar
Control pressure min./max.	3 ... 8 bar
Ambient temperature min./max.	-5 ... 50 °C
Medium temperature min./max.	0 ... 50 °C
Medium	Compressed air
Max. particle size	5 µm
Oil content of compressed air	0 ... 5 mg/m ³
Nominal flow Qn	400 l/min
Pilot control exhaust	With collective pilot air exhaust
Protection class with connection	IP65
Protective circuit	Z-diode
Reverse polarity protection	Protected against polarity reversal
LED status display	Yellow
Duty cycle	100 %
Typ. switch-on time	13 ms
Typ. switch-off time	20 ms
mounting screws	cross recessed DIN EN ISO 4757-Z0
Mounting screw tightening torque	0.25 Nm
Weight	0.048 kg

Technical data

Part No.		MO		Operational voltage	
				DC	Voltage tolerance
0820062101			NC/NC	24 V	-10% / +10%
0820062201			NO/NO	24 V	-10% / +10%
0820062301			NC/NO	24 V	-10% / +10%

Part No.	Power consumption	
	DC	
0820062101	0.55 W	
0820062201	0.55 W	
0820062301	0.55 W	

Nominal flow Q_n at 6 bar and $\Delta p = 1$ bar, MO = Manual override

Technical information

The min. control pressure must be adhered to, since otherwise faulty switching and valve failure may result!

The pressure dew point must be at least 15 °C under ambient and medium temperature and may not exceed 3 °C .

The oil content of compressed air must remain constant during the life cycle.

Use only the approved oils from AVENTICS. Further information can be found in the "Technical information" document (available in the MediaCentre).

The pilot type (external/internal) is not implemented in the valve, but in the end plate of the valve system.

Technical information

Material	
Housing	Polyamide
Seals	Acrylonitrile butadiene rubber Polyurethane







2x3/2-directional valve, Series HF04

- For series : HF04, LP04, HF04-XF
- 2x3/2
- $Q_n = 400$ l/min
- Pilot valve width : 10 mm
- NC/NC NO/NO NC/NO
- Plate connection
- Manual override : without detent
- Pilot : External, Internal



Version	Spool valve, positive overlapping
Activation	Electrically
Pilot	External, Internal
Sealing principle	Soft sealing
Blocking principle	Double base plate principle
Working pressure min./max.	-0.9 ... 10 bar
Control pressure min./max.	3 ... 8 bar
Ambient temperature min./max.	-5 ... 50 °C
Medium temperature min./max.	0 ... 50 °C
Medium	Compressed air
Max. particle size	5 µm
Oil content of compressed air	0 ... 5 mg/m ³
Nominal flow Q_n	400 l/min
Protection class with connection	IP65
Protective circuit	Z-diode
Reverse polarity protection	Protected against polarity reversal
LED status display	Yellow
Duty cycle	100 %
Typ. switch-on time	13 ms
Typ. switch-off time	20 ms
mounting screws	cross recessed DIN EN ISO 4757-Z0
Mounting screw tightening torque	0.25 Nm
Weight	0.048 kg

Technical data

Part No.		MO		Operational voltage	
				DC	DC
0820062102			NC/NC	24 V	-10% / +10%
0820062202			NO/NO	24 V	-10% / +10%
0820062302			NC/NO	24 V	-10% / +10%

Part No.	Power consumption	
	DC	
0820062102	0.55 W	
0820062202	0.55 W	
0820062302	0.55 W	

Nominal flow Q_n at 6 bar and $\Delta p = 1$ bar, MO = Manual override

Technical information

The min. control pressure must be adhered to, since otherwise faulty switching and valve failure may result!

The pressure dew point must be at least 15 °C under ambient and medium temperature and may not exceed 3 °C .

The oil content of compressed air must remain constant during the life cycle.

Use only the approved oils from AVENTICS. Further information can be found in the “Technical information” document (available in the MediaCentre).

The pilot type (external/internal) is not implemented in the valve, but in the end plate of the valve system.

Technical information

Material	
Housing	Polyamide
Seals	Acrylonitrile butadiene rubber Polyurethane

Dimensions

Dimensions

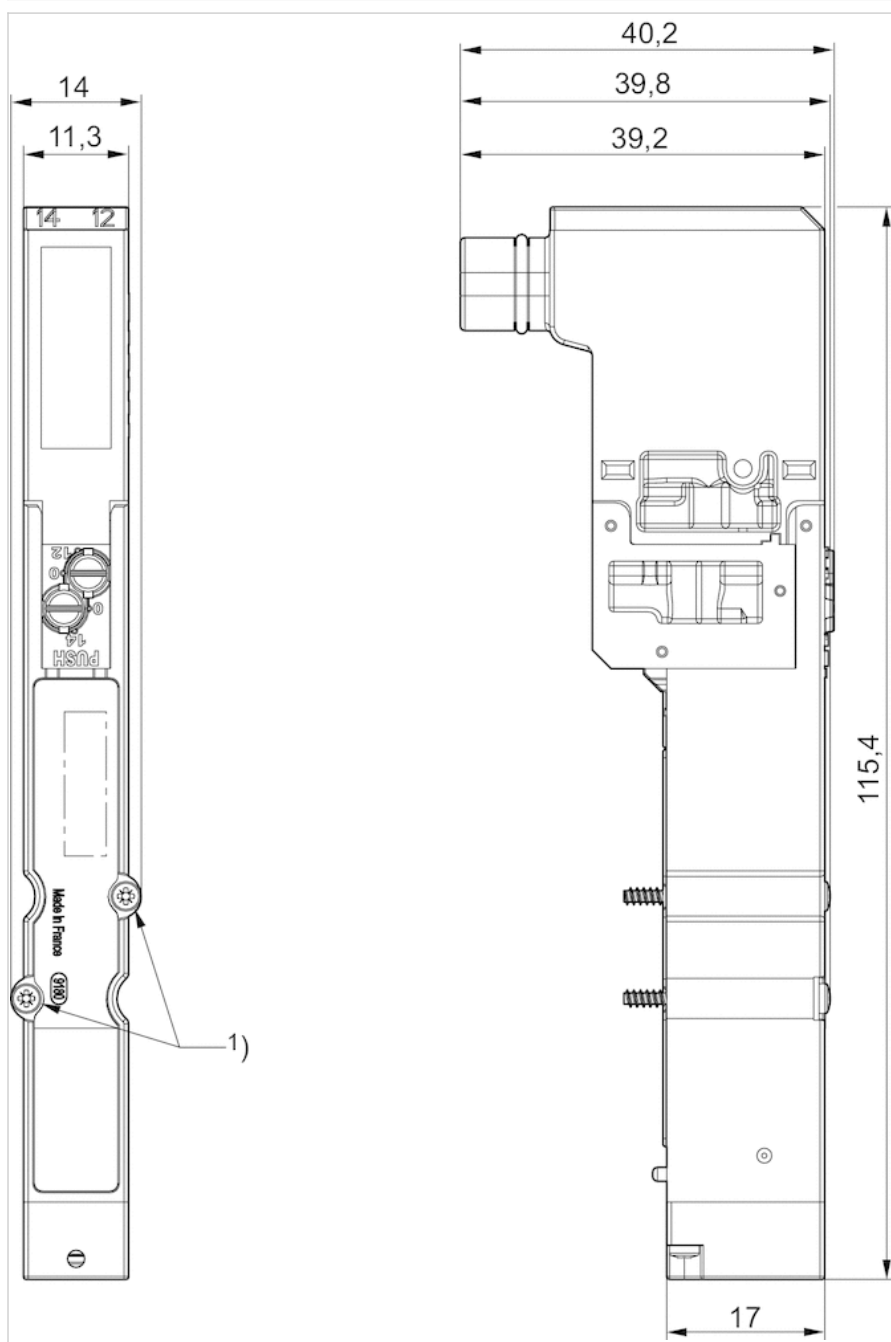

1) Mounting screw: X-slot DIN EN ISO 4757-Z0
tightening torque for mounting screw [Nm]: 0.25







5/2-directional valve, Series HF04

- For series : HF04, LP04, HF04-XF
- 5/2
- Qn = 400 l/min
- Pilot valve width : 10 mm
- Plate connection
- Manual override : with detent
- single solenoid double solenoid
- Pilot : External, Internal



Version	Spool valve, positive overlapping
Activation	Electrically
Pilot	External, Internal
Sealing principle	Soft sealing
Blocking principle	Double base plate principle
Working pressure min./max.	-0.9 ... 10 bar
Control pressure min./max.	3 ... 8 bar
Ambient temperature min./max.	-5 ... 50 °C
Medium temperature min./max.	0 ... 50 °C
Medium	Compressed air
Max. particle size	5 µm
Oil content of compressed air	0 ... 5 mg/m ³
Nominal flow Qn	400 l/min
Protection class with connection	IP65
Protective circuit	Z-diode
Reverse polarity protection	Protected against polarity reversal
LED status display	Yellow
Duty cycle	100 %
mounting screws	cross recessed DIN EN ISO 4757-Z0
Mounting screw tightening torque	0.25 Nm
Weight	0.048 kg

Technical data

Part No.		MO	Operational voltage	Voltage tolerance
			DC	DC
0820062051			24 V	-10% / +10%
0820062001			24 V	-10% / +10%
0820062501			24 V	-10% / +10%

Part No.	Power consumption	Typ. switch-on time	Typ. switch-off time
	DC		
0820062051	0.55 W	9 ms	28 ms
0820062001	0.55 W	16 ms	18 ms
0820062501	0.55 W	7 ms	8 ms

Nominal flow Qn at 6 bar and $\Delta p = 1$ bar, MO = Manual override

Technical information

The min. control pressure must be adhered to, since otherwise faulty switching and valve failure may result!

The pressure dew point must be at least 15 °C under ambient and medium temperature and may not exceed 3 °C .

The oil content of compressed air must remain constant during the life cycle.

Use only the approved oils from AVENTICS. Further information can be found in the "Technical information" document (available in the MediaCentre).

The pilot type (external/internal) is not implemented in the valve, but in the end plate of the valve system.

Technical information

Material	
Housing	Polyamide
Seals	Acrylonitrile butadiene rubber Polyurethane

Dimensions

Dimensions

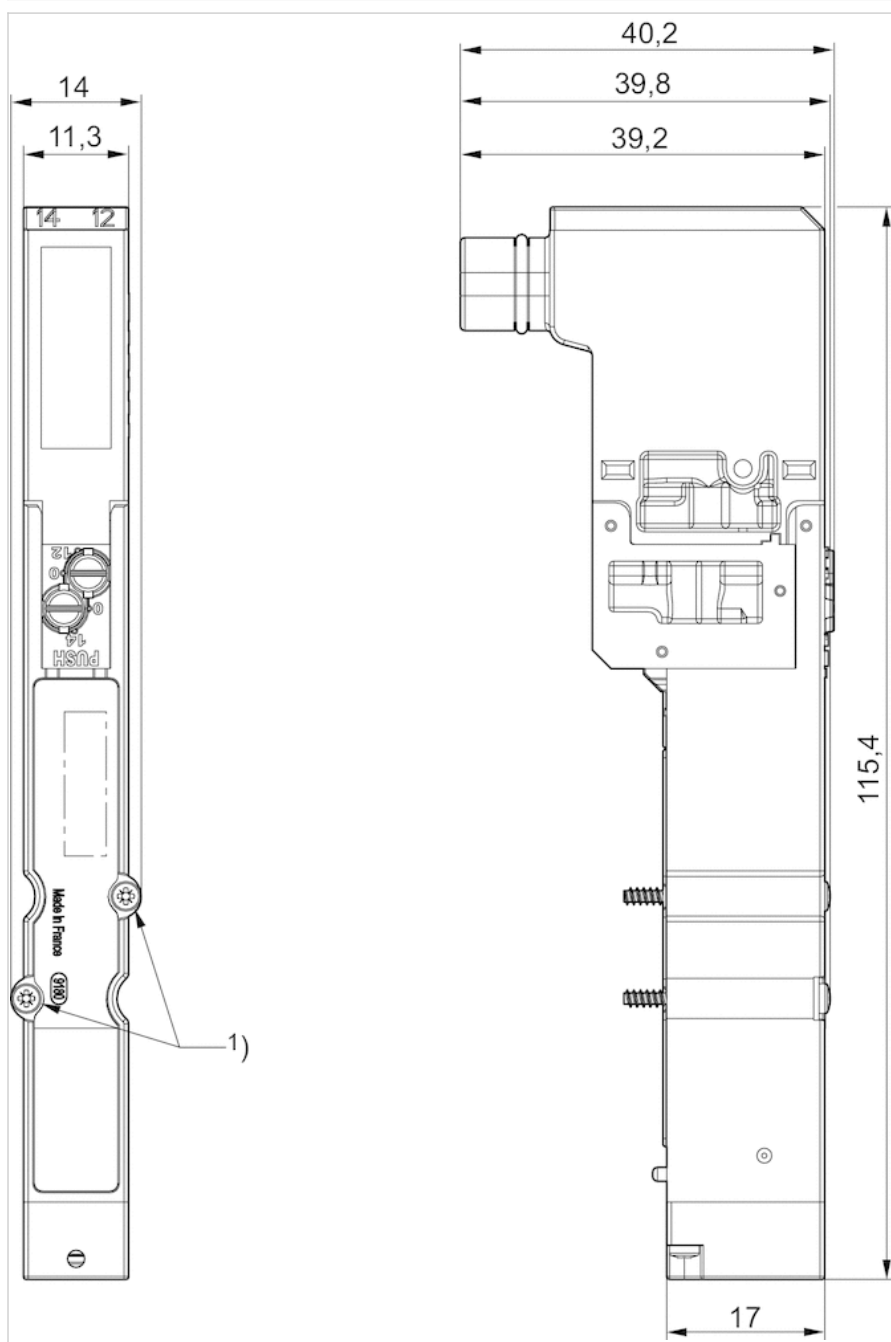

1) Mounting screw: X-slot DIN EN ISO 4757-Z0
tightening torque for mounting screw [Nm]: 0.25



5/2-directional valve, Series HF04

- For series : HF04, LP04, HF04-XF
- 5/2
- Qn = 400 l/min
- Pilot valve width : 10 mm
- Plate connection
- Manual override : without detent
- single solenoid double solenoid
- Pilot : External, Internal



Version	Spool valve, positive overlapping
Activation	Electrically
Pilot	External, Internal
Sealing principle	Soft sealing
Blocking principle	Double base plate principle
Working pressure min./max.	-0.9 ... 10 bar
Control pressure min./max.	3 ... 8 bar
Ambient temperature min./max.	-5 ... 50 °C
Medium temperature min./max.	0 ... 50 °C
Medium	Compressed air
Max. particle size	5 µm
Oil content of compressed air	0 ... 5 mg/m ³
Nominal flow Qn	400 l/min
Protection class with connection	IP65
Protective circuit	Z-diode
Reverse polarity protection	Protected against polarity reversal
LED status display	Yellow
Duty cycle	100 %
mounting screws	cross recessed DIN EN ISO 4757-Z0
Mounting screw tightening torque	0.25 Nm
Weight	0.048 kg

Technical data

Part No.	MO	Operational voltage	Voltage tolerance	
			DC	DC
0820062052		24 V	-10% / +10%	-10% / +10%
0820062002		24 V	-10% / +10%	-10% / +10%
0820062502		24 V	-10% / +10%	-10% / +10%

Part No.	Power consumption		Typ. switch-on time	Typ. switch-off time
	DC			
0820062052	0.55 W		9 ms	28 ms
0820062002	0.55 W		16 ms	18 ms
0820062502	0.55 W		7 ms	8 ms

Nominal flow Qn at 6 bar and $\Delta p = 1$ bar, MO = Manual override

Technical information

The min. control pressure must be adhered to, since otherwise faulty switching and valve failure may result!

The pressure dew point must be at least 15 °C under ambient and medium temperature and may not exceed 3 °C .

The oil content of compressed air must remain constant during the life cycle.

Use only the approved oils from AVENTICS. Further information can be found in the “Technical information” document (available in the MediaCentre).

The pilot type (external/internal) is not implemented in the valve, but in the end plate of the valve system.

Technical information

Material	
Housing	Polyamide
Seals	Acrylonitrile butadiene rubber Polyurethane

Dimensions

Dimensions

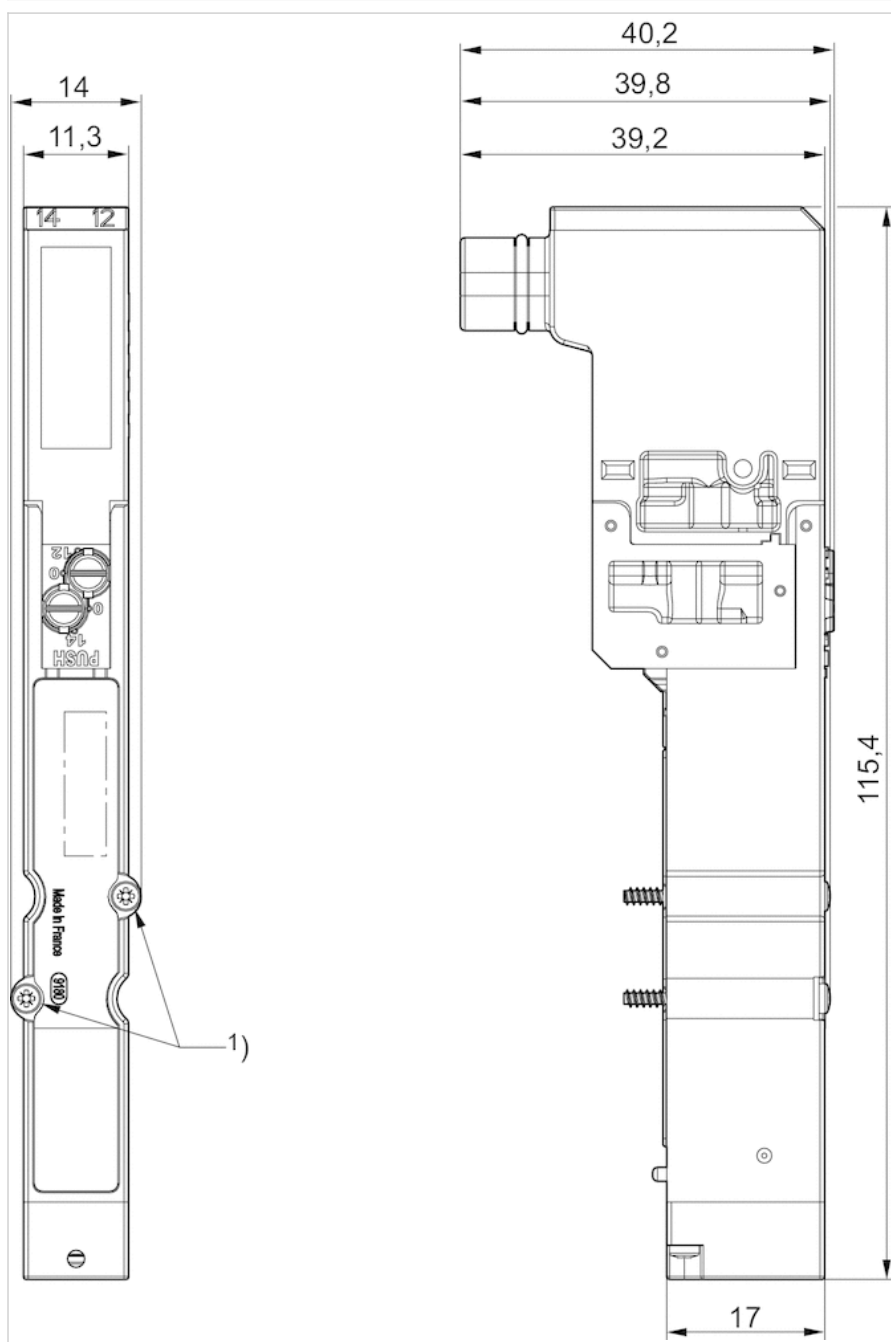

1) Mounting screw: X-slot DIN EN ISO 4757-Z0
tightening torque for mounting screw [Nm]: 0.25

5/3-directional valve, Series HF04

- For series : HF04, LP04, HF04-XF
- 5/3
- Qn = 400 l/min
- Pilot valve width : 10 mm
- closed center
- Plate connection
- Manual override : with detent
- Pilot : External, Internal

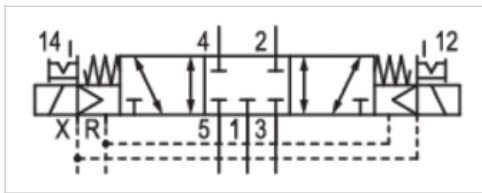

Version	Spool valve, positive overlapping
Activation	Electrically
Pilot	External, Internal
Sealing principle	Soft sealing
Blocking principle	Double base plate principle
Working pressure min./max.	-0.9 ... 10 bar
Control pressure min./max.	3 ... 8 bar
Ambient temperature min./max.	-5 ... 50 °C
Medium temperature min./max.	0 ... 50 °C
Medium	Compressed air
Max. particle size	5 µm
Oil content of compressed air	0 ... 5 mg/m³
Nominal flow Qn	400 l/min
Protection class with connection	IP65
Protective circuit	Z-diode
Reverse polarity protection	Protected against polarity reversal
LED status display	Yellow
Duty cycle	100 %
Typ. switch-on time	8 ms
Typ. switch-off time	10 ms
mounting screws	cross recessed DIN EN ISO 4757-Z0
Mounting screw tightening torque	0.25 Nm
Weight	0.048 kg

Technical data

Part No.	MO		Operational voltage	
			DC	Voltage tolerance
0820062601		closed center	24 V	DC -10% / +10%

Part No.	Power consumption	
	DC	
0820062601	0.55 W	

Nominal flow Qn at 6 bar and Δp = 1 bar, MO = Manual override

Technical information

The min. control pressure must be adhered to, since otherwise faulty switching and valve failure may result!

The pressure dew point must be at least 15 °C under ambient and medium temperature and may not exceed 3 °C .

The oil content of compressed air must remain constant during the life cycle.

Use only the approved oils from AVENTICS. Further information can be found in the "Technical information" document (available in the MediaCentre).

The pilot type (external/internal) is not implemented in the valve, but in the end plate of the valve system.

Technical information

Material	
Housing	Polyamide
Seals	Acrylonitrile butadiene rubber Polyurethane

Dimensions

Dimensions

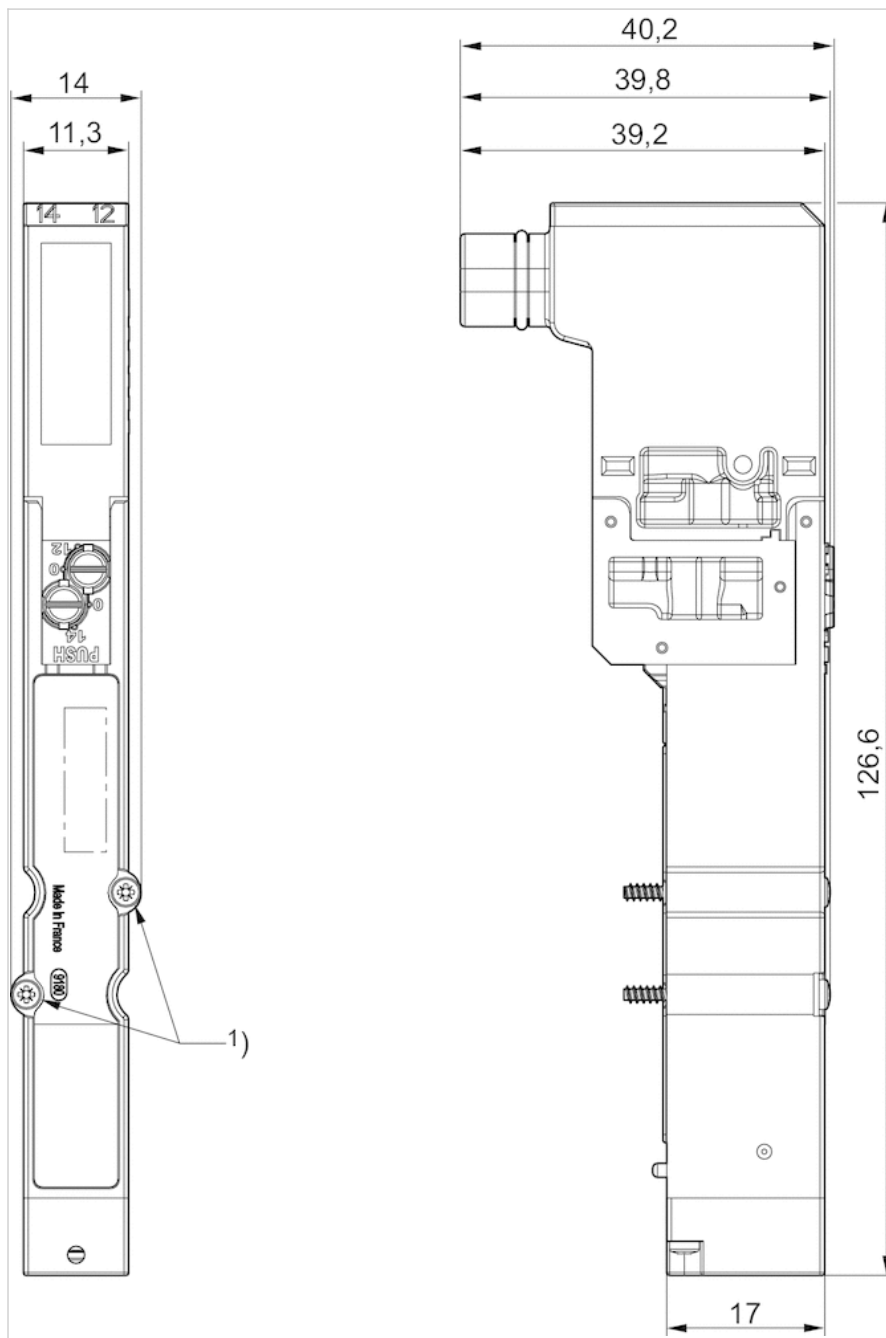

1) Mounting screw: X-slot DIN EN ISO 4757-Z0
tightening torque for mounting screw [Nm]: 0.25

5/3-directional valve, Series HF04

- For series : HF04, LP04, HF04-XF
- 5/3
- Qn = 400 l/min
- Pilot valve width : 10 mm
- closed center
- Plate connection
- Manual override : without detent
- Pilot : External, Internal

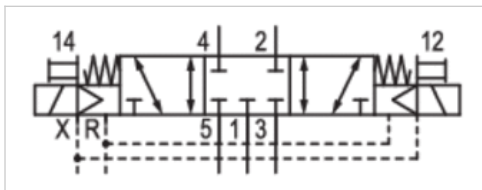

Version	Spool valve, positive overlapping
Activation	Electrically
Pilot	External, Internal
Sealing principle	Soft sealing
Blocking principle	Double base plate principle
Working pressure min./max.	-0.9 ... 10 bar
Control pressure min./max.	3 ... 8 bar
Ambient temperature min./max.	-5 ... 50 °C
Medium temperature min./max.	0 ... 50 °C
Medium	Compressed air
Max. particle size	5 µm
Oil content of compressed air	0 ... 5 mg/m³
Nominal flow Qn	400 l/min
Protection class with connection	IP65
Protective circuit	Z-diode
Reverse polarity protection	Protected against polarity reversal
LED status display	Yellow
Duty cycle	100 %
Typ. switch-on time	8 ms
Typ. switch-off time	10 ms
mounting screws	cross recessed DIN EN ISO 4757-Z0
Mounting screw tightening torque	0.25 Nm
Weight	0.048 kg

Technical data

Part No.	MO		Operational voltage	
			DC	Voltage tolerance
0820062602		closed center	24 V	DC -10% / +10%

Part No.	Power consumption	
	DC	
0820062602	0.55 W	

Nominal flow Qn at 6 bar and Δp = 1 bar, MO = Manual override

Technical information

The min. control pressure must be adhered to, since otherwise faulty switching and valve failure may result!

The pressure dew point must be at least 15 °C under ambient and medium temperature and may not exceed 3 °C .

The oil content of compressed air must remain constant during the life cycle.

Use only the approved oils from AVENTICS. Further information can be found in the “Technical information” document (available in the MediaCentre).

The pilot type (external/internal) is not implemented in the valve, but in the end plate of the valve system.

Technical information

Material	
Housing	Polyamide
Seals	Acrylonitrile butadiene rubber Polyurethane

Dimensions

Dimensions

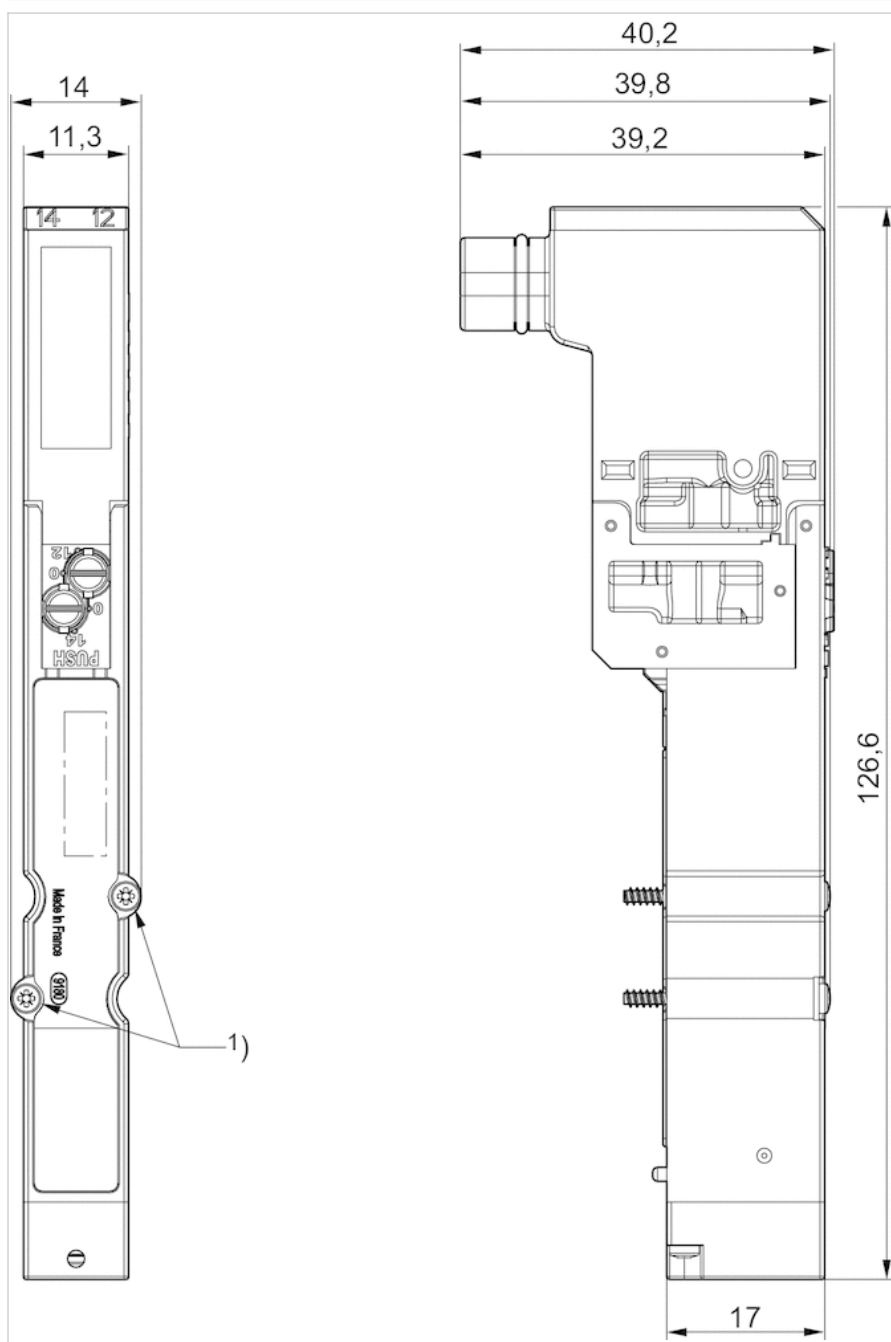

1) Mounting screw: X-slot DIN EN ISO 4757-Z0
tightening torque for mounting screw [Nm]: 0.25

Series BDC

- B-design
- Bus coupler with driver
- Fieldbus protocol EtherCAT PROFIBUS DP CANopen CANopen sb DeviceNet sercos III



Version	Bus coupler with driver
Ambient temperature min./max.	0 ... 50 °C
Operational voltage electronics	24 V DC
Electronics voltage tolerance	-15% / +20%
Power consumption electronics	0.05 A
Operating voltage, actuators	24 V DC
Total current for actuators	3 A
Protection class	IP65
Number of solenoid coils max.	32
Max. power consumption per coil	0.1 mA
Generic emission standard in accordance with norm	EN 61000-6-4
Generic immunity standard in accordance with norm	IEC 61000-6-2
Weight	0.29 kg

Technical data

Part No.	Fieldbus protocol	Port
		1
R412009573	EtherCAT	Socket (female), M12x1, 5-pin, D-coded
R412008537	PROFIBUS DP	Plug (male), M12x1, 5-pin, B-coded
R412008538	CANopen	Plug (male), M12x1, 5-pin, A-coded
R412008990	CANopen sb	Plug (male), M12x1, 5-pin, A-coded
R412008539	DeviceNet	Plug (male), M12x1, 5-pin, A-coded
R412009516	sercos III	Socket (female), M12x1, 5-pin, D-coded

Part No.	Port	power supply
	2	
R412009573	Socket (female), M12x1, 5-pin, D-coded	Plug (male), M12, 4-pin, A-coded
R412008537	Socket (female), M12x1, 5-pin, B-coded	Plug (male), M12, 4-pin, A-coded
R412008538	Socket (female), M12x1, 5-pin, A-coded	Plug (male), M12, 4-pin, A-coded
R412008990	Socket (female), M12x1, 5-pin, A-coded	Plug (male), M12, 4-pin, A-coded
R412008539	Socket (female), M12x1, 5-pin, A-coded	Plug (male), M12, 4-pin, A-coded
R412009516	Socket (female), M12x1, 5-pin, D-coded	Plug (male), M12, 4-pin, A-coded

Scope of delivery incl. 2 screws and seal, The following operating instructions can be found in the Media Center for: ←PROFIBUS DP: R412009414 ←CANopen /-sb: R412009415 ←DeviceNet: R412009416 ←EtherCAT: R412012792 ←sercos III: R412012610

Technical information

Max. number of valves: 16 double solenoid or 32 single solenoid

You will find assignment schemes for the product in the operating instructions, or contact the nearest AVENTICS sales office.

Caution: A reduced temperature range in accordance with the operating instructions may need to be considered in ATEX applications.

Technical information

Material

Housing

Die-cast aluminum

Dimensions

Dimensions

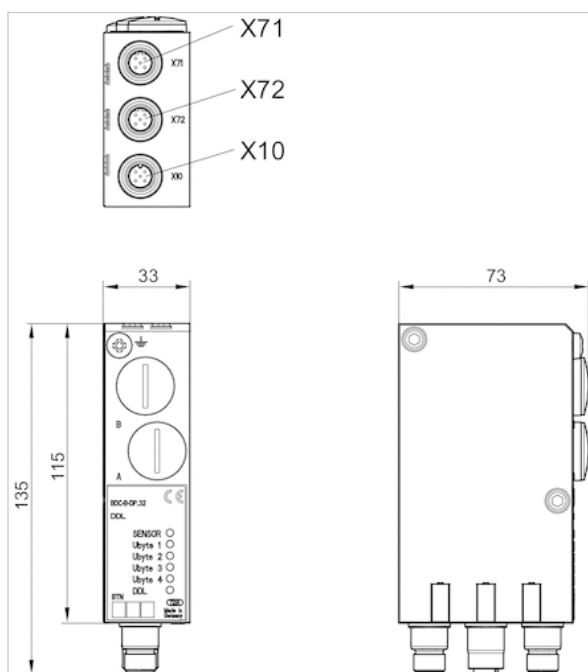

X71 = Bus IN

X72 = Bus OUT

X10 = power supply

Series AS-i, B-design

- B-design
- Bus coupler with driver
- Yellow AS-i flat cable
- Fieldbus protocol AS-i



Version	Bus coupler with driver
Ambient temperature min./max.	0 ... 50 °C
Operating voltage, actuators	24 V DC
Protection class	IP65
Max. power consumption per coil	0.03 mA
Port Valve system	Socket, 2.0 mm strip, 2x13-pin
ID Code / ID2 Code	F / E
I/O Code	8
Generic emission standard in accordance with norm	EN 50295
Generic immunity standard in accordance with norm	EN 50295
Weight	0.14 kg

The delivered product may vary from that in the illustration.

Technical data

Part No.	Fieldbus protocol	Port	power supply
		1	
R412003488	AS-i	Yellow AS-i flat cable	Black AS-i flat cable
R412006761	AS-i	Yellow AS-i flat cable	Black AS-i flat cable

Part No.	Number of outputs for valve coils	Power consumption electronics	Fig.
R412003488	4	0.05 A	Fig. 1
R412006761	8	0.08 A	Fig. 2

Scope of delivery incl. seal and mounting screws, The following operating instructions can be found in the Media Center for: →AS-i: R499050017

Technical information

Caution: A reduced temperature range in accordance with the operating instructions may need to be considered in ATEX applications. You will find assignment schemes for the product in the operating instructions, or contact the nearest AVENTICS sales office.

Technical information

Material	
Housing	Aluminum Die-cast aluminum

Dimensions

Fig. 1

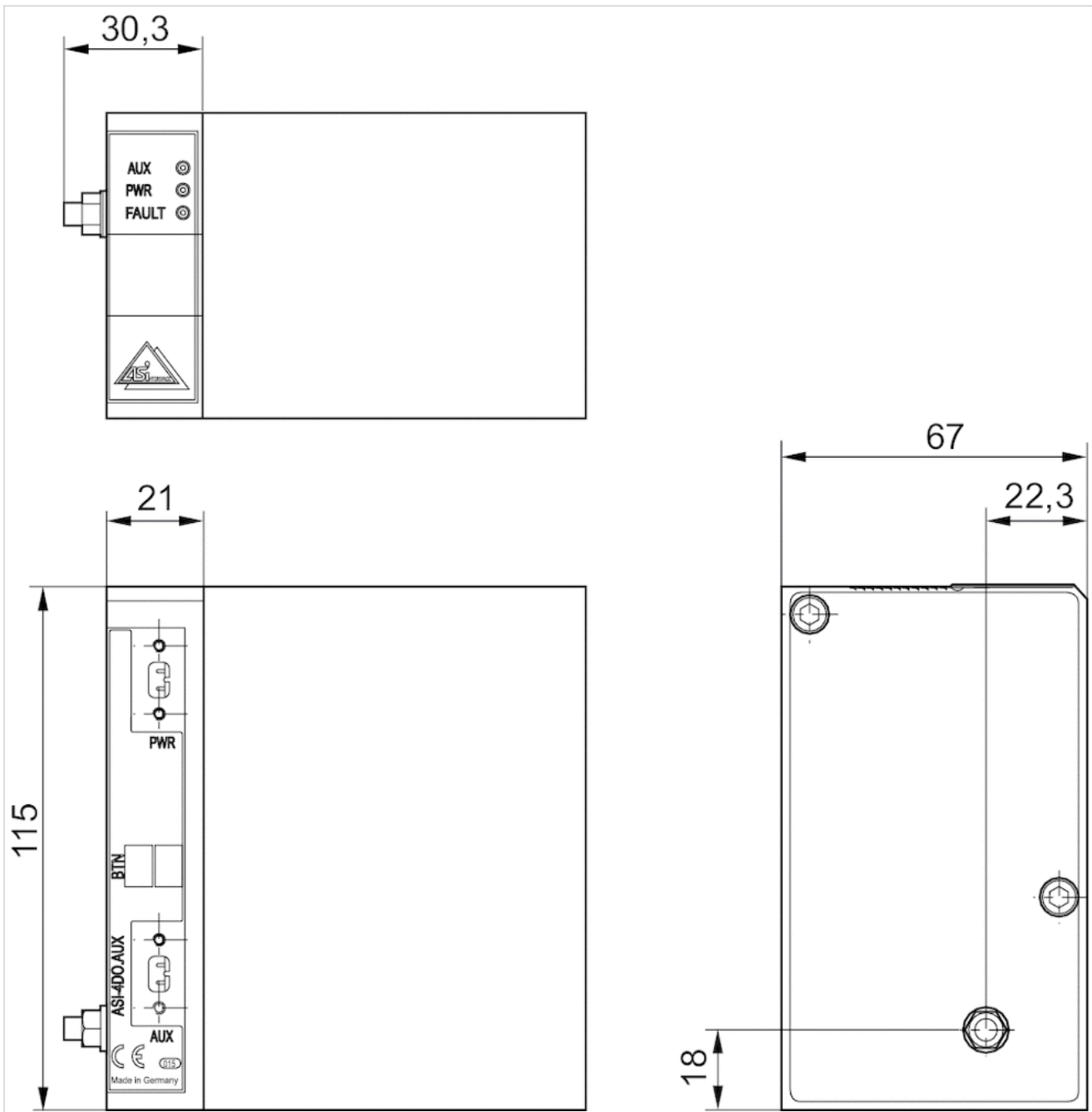

AS-i, 4DO-AUX

Fig. 2

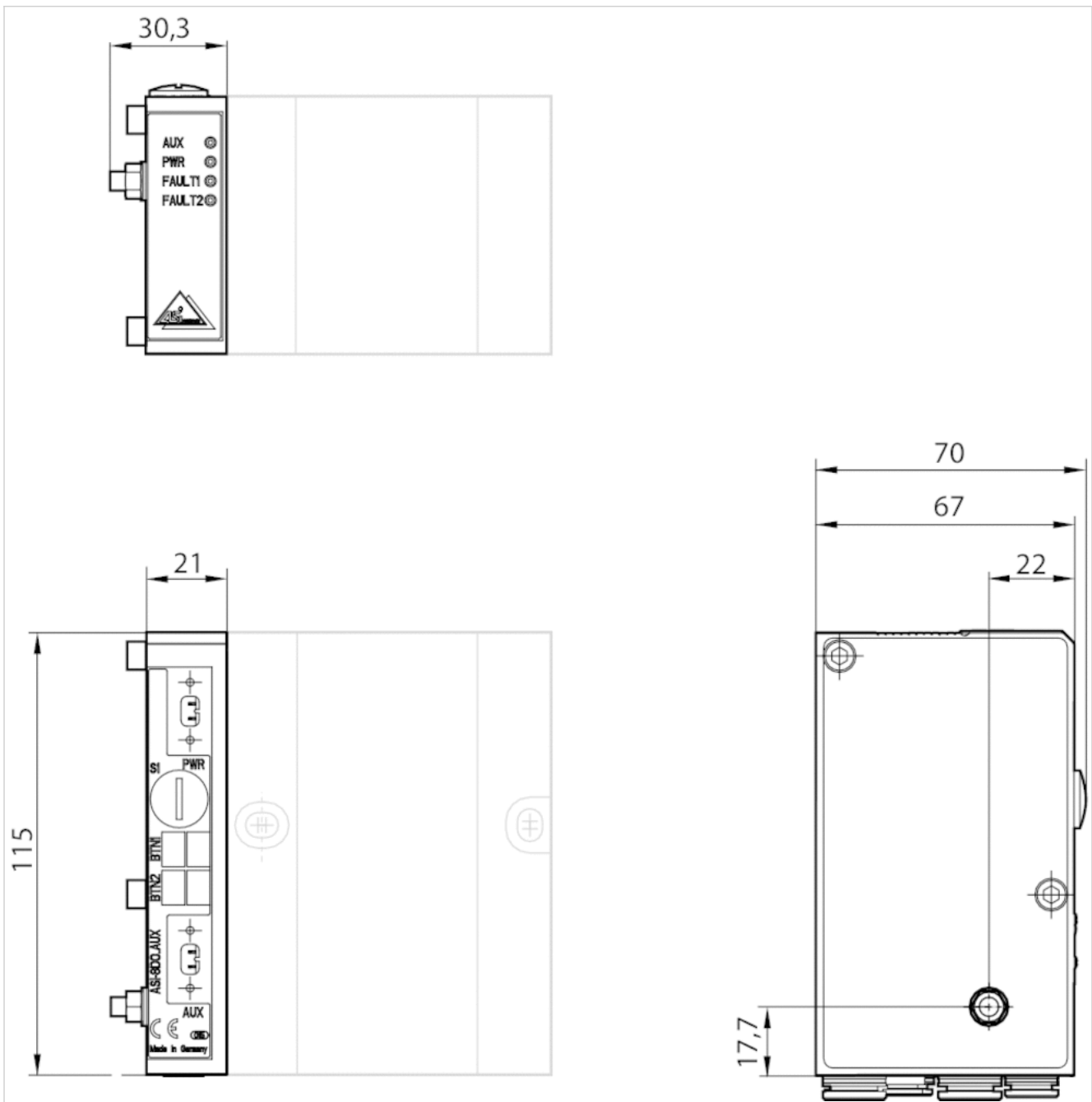

AS-i, 8DO-AUX

Series AS-i, B-design

- B-design
- Bus coupler with driver
- Yellow AS-i flat cable
- Fieldbus protocol AS i with inputs



Version	Bus coupler with driver
Ambient temperature min./max.	0 ... 50 °C
Operating voltage, actuators	24 V DC
Protection class	IP65
Max. power consumption per coil	0.03 mA
Port Valve system	Socket, 2.0 mm strip, 2x13-pin
ID Code / ID2 Code	F / E
I/O connection	input or output, Socket, M8
I/O Code	7
Generic emission standard in accordance with norm	EN 50295
Generic immunity standard in accordance with norm	EN 50295

The delivered product may vary from that in the illustration.

Technical data

Part No.	Fieldbus protocol	Port	power supply	Number of inputs
		1		
R412003486	AS i with inputs	Yellow AS-i flat cable	Black AS-i flat cable	8
R412003487	AS i with inputs	Yellow AS-i flat cable	Black AS-i flat cable	4

Part No.	Number of outputs for valve coils	I/O connection	I/O connection
			Number
R412003486	8	input or output, Socket, M8	8
R412003487	4	input or output, Socket, M8	4

Part No.	Power consumption electronics	Fig.
R412003486	0.1 A	Fig. 2
R412003487	0.05 A	Fig. 1

Scope of delivery incl. 2 tie rod extensions and seal, The following operating instructions can be found in the Media Center for: ←AS-i: R499050017

Technical information

Caution: A reduced temperature range in accordance with the operating instructions may need to be considered in ATEX applications. You will find assignment schemes for the product in the operating instructions, or contact the nearest AVENTICS sales office.

Technical information

Material

Housing

Aluminum

Dimensions

Fig. 1

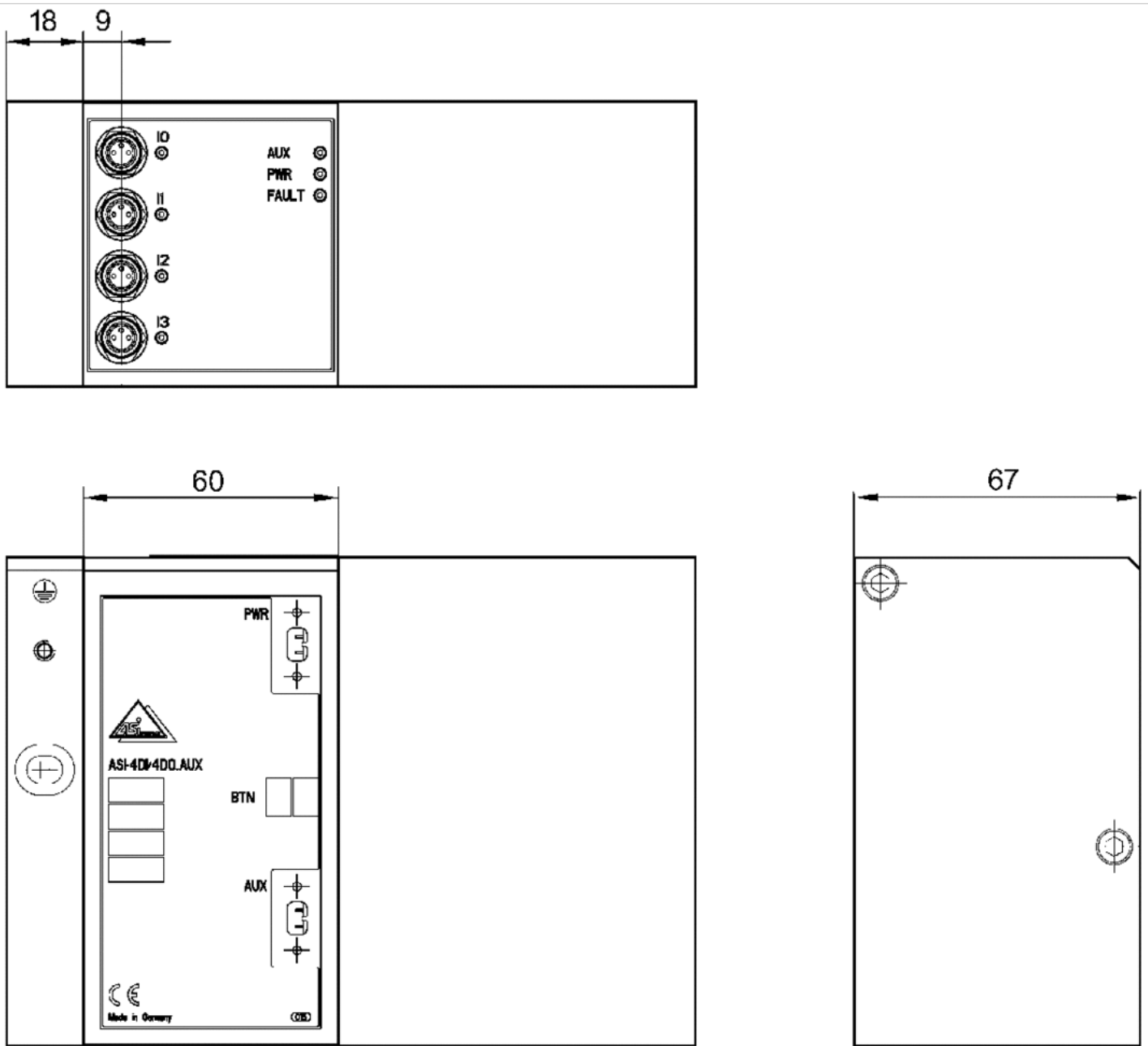

4DI/4DO-AUX

Fig. 2

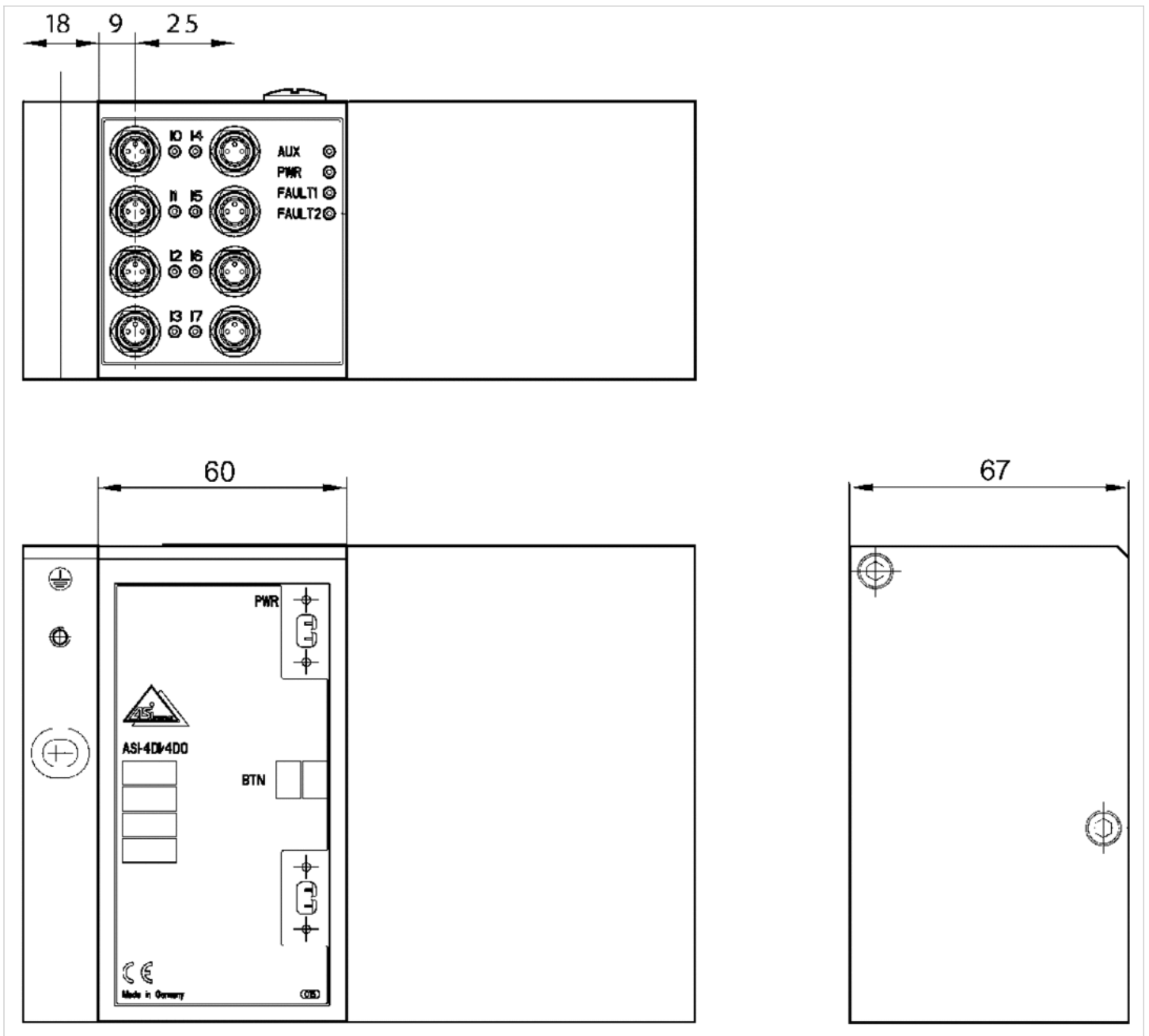

8DI/8DO-AUX

Adapter module

- for series AES on B-design
- for series HF02-LG, HF03-LG, HF04, CD01-PI, CD10-PI, CD20-PI



Ambient temperature min./max. -10 ... 60 °C
 Weight 0.16 kg

Technical data

Part No.	Type	Scope of delivery	Scope of delivery
R412023458	32 outputs	Includes screws and seals.	1 piece

Technical information

The adapter module is mounted on valve systems with a B-design interface for use with AES fieldbus couplers and AES I/O modules. See the operating instructions for further information (R412018150).

Technical information

Material	
Housing	Aluminum
Seals	Nitrile rubber

Dimensions

Dimensions

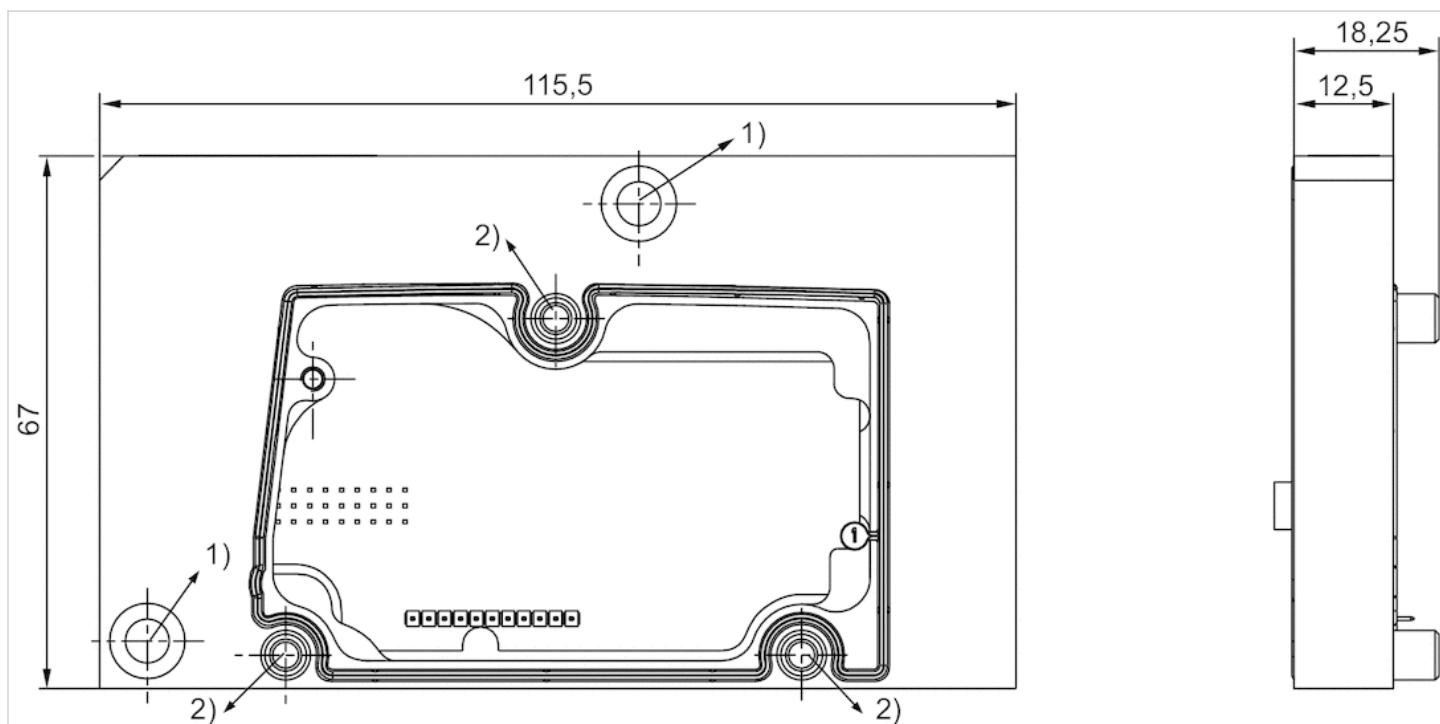

Includes screws and seals.

1) Torque: 3 Nm +0.5 Nm

2) Torque: 1.6 Nm +0.4 Nm

Optional fieldbus connection with I/O function (CMS), B-design

- B-design
- Bus coupler with driver
- Fieldbus protocol PROFIBUS DP CANopen DeviceNet EtherNET/IP PROFINET IO



Version	Bus coupler with driver
Ambient temperature min./max.	0 ... 50 °C
Operational voltage electronics	24 V DC
Electronics voltage tolerance	-15% / +20%
Operating voltage, actuators	24 V DC
Protection class	IP65
I/O module extension max.	6
Weight	See table below
	The delivered product may vary from that in the illustration.

Technical data

Part No.	Fieldbus protocol	Port
		1
R412003484	PROFIBUS DP	Plug (male), M12, 5-pin, B-coded
R412008516	PROFIBUS DP	Plug (male), M12, 5-pin, B-coded
R412005747	CANopen	Plug (male), M12, 5-pin, A-coded
R412008518	CANopen	Plug (male), M12, 5-pin, A-coded
R412004346	DeviceNet	Plug (male), M12, 5-pin, A-coded
R412008517	DeviceNet	Plug (male), M12, 5-pin, A-coded
R412012755	EtherNET/IP	-
R412014581	PROFINET IO	Socket (female), M12x1, 4-pin, D-coded
R412014583	PROFINET IO	Socket (female), M12x1, 4-pin, D-coded

Part No.	Port	power supply
	2	
R412003484	Socket (female), M12, 5-pin, B-coded	Plug (male), M12, 4-pin, A-coded
R412008516	Socket (female), M12, 5-pin, B-coded	Plug (male), M12, 4-pin, A-coded
R412005747	Socket (female), M12, 5-pin, A-coded	Plug (male), M12, 4-pin, A-coded
R412008518	Socket (female), M12, 5-pin, A-coded	Plug (male), M12, 4-pin, A-coded
R412004346	Socket (female), M12, 5-pin, A-coded	Plug (male), M12, 4-pin, A-coded
R412008517	Socket (female), M12, 5-pin, A-coded	Plug (male), M12, 4-pin, A-coded
R412012755	Socket (female), M12, 5-pin, D-coded	Plug (male), M12, 4-pin, A-coded
R412014581	Socket (female), M12x1, 4-pin, D-coded	Plug (male), M12x1, 4-pin, A-coded
R412014583	Socket (female), M12x1, 4-pin, D-coded	Plug (male), 7/8"-16UNF, 5-pin

Part No.	Number of outputs for valve coils	Port
		Valve system
R412003484	24	Socket, 2.0 mm strip, 2x13-pin
R412008516	32	Socket, 2.0 mm strip, 3x13-pin

Part No.	Number of outputs for valve coils	Port
		Valve system
R412005747	24	Socket, 2.0 mm strip, 2x13-pin
R412008518	32	Socket, 2.0 mm strip, 3x13-pin
R412004346	24	Socket, 2.0 mm strip, 2x13-pin
R412008517	32	Socket, 2.0 mm strip, 3x13-pin
R412012755	32	Socket, 2.0 mm strip, 3x13-pin
R412014581	32	-
R412014583	32	-

Part No.	Power consumption electronics	Max. power consumption per coil	Weight	Fig.	
R412003484	0.12 A	0.063 mA	0.84 kg	Fig. 1	1)
R412008516	0.12 A	0.063 mA	0.84 kg	Fig. 1	1)
R412005747	0.12 A	0.063 mA	1 kg	Fig. 1	1)
R412008518	0.12 A	0.063 mA	1 kg	Fig. 1	1)
R412004346	0.12 A	0.063 mA	1 kg	Fig. 1	1)
R412008517	0.12 A	0.063 mA	1 kg	Fig. 1	1)
R412012755	0.12 A	0.063 mA	1 kg	Fig. 2	2)
R412014581	0.1 A	0.1 mA	0.91 kg	Fig. 1	1)
R412014583	0.1 A	0.1 mA	0.91 kg	Fig. 3	1)

Scope of delivery incl. 2 tie rod extensions and seal, The following operating instructions can be found in the Media Center for:↔PROFIBUS DP: R499050016↔CANopen: R412005742↔DeviceNet: R499050019↔EtherNET/IP: R412012728

1) Connection with two valve voltage circuits.

2) Connection with two valve voltage circuits., Only star topology

Technical information

Caution: A reduced temperature range in accordance with the operating instructions may need to be considered in ATEX applications. You will find assignment schemes for the product in the operating instructions, or contact the nearest AVENTICS sales office.

Technical information

Material	
Housing	Die-cast aluminum

Dimensions

Fig. 1

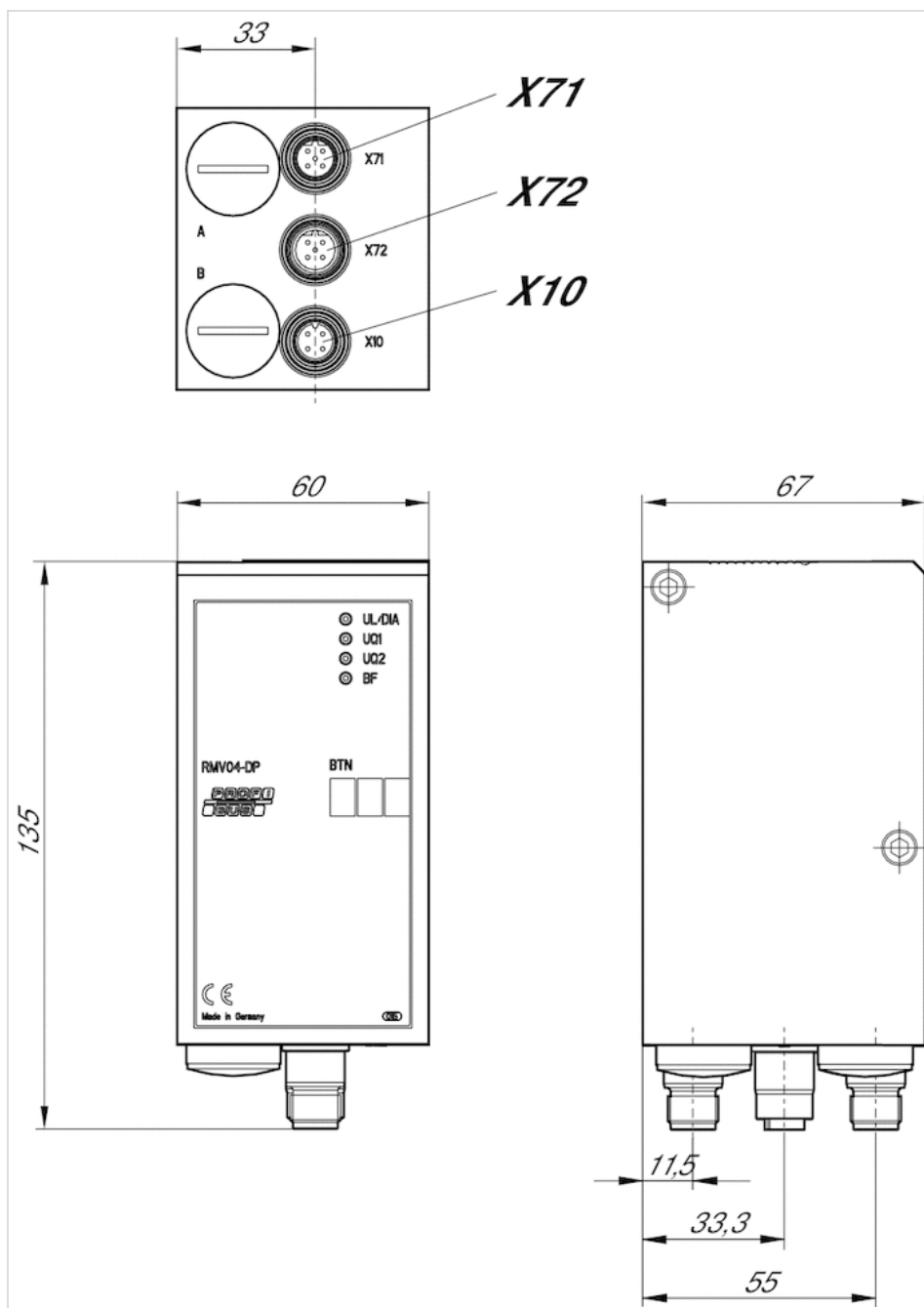

- X71, (Bus IN), M12x1
- X72, (Bus OUT), M12x1
- X10, (Power), M12x1

Fig. 2

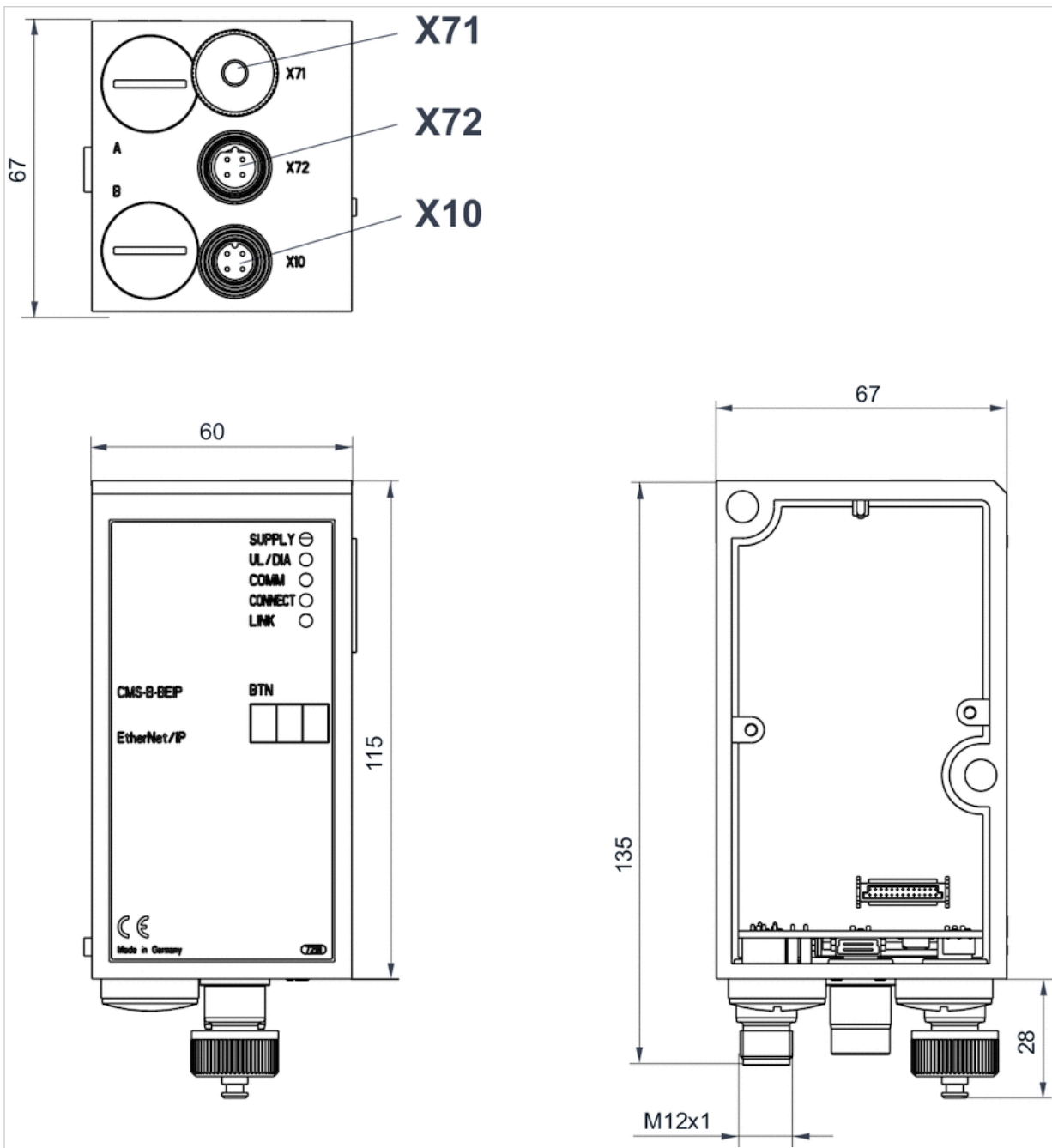

- X71 = optional interface
- X72 = Bus
- X10 = Power

Fig. 3

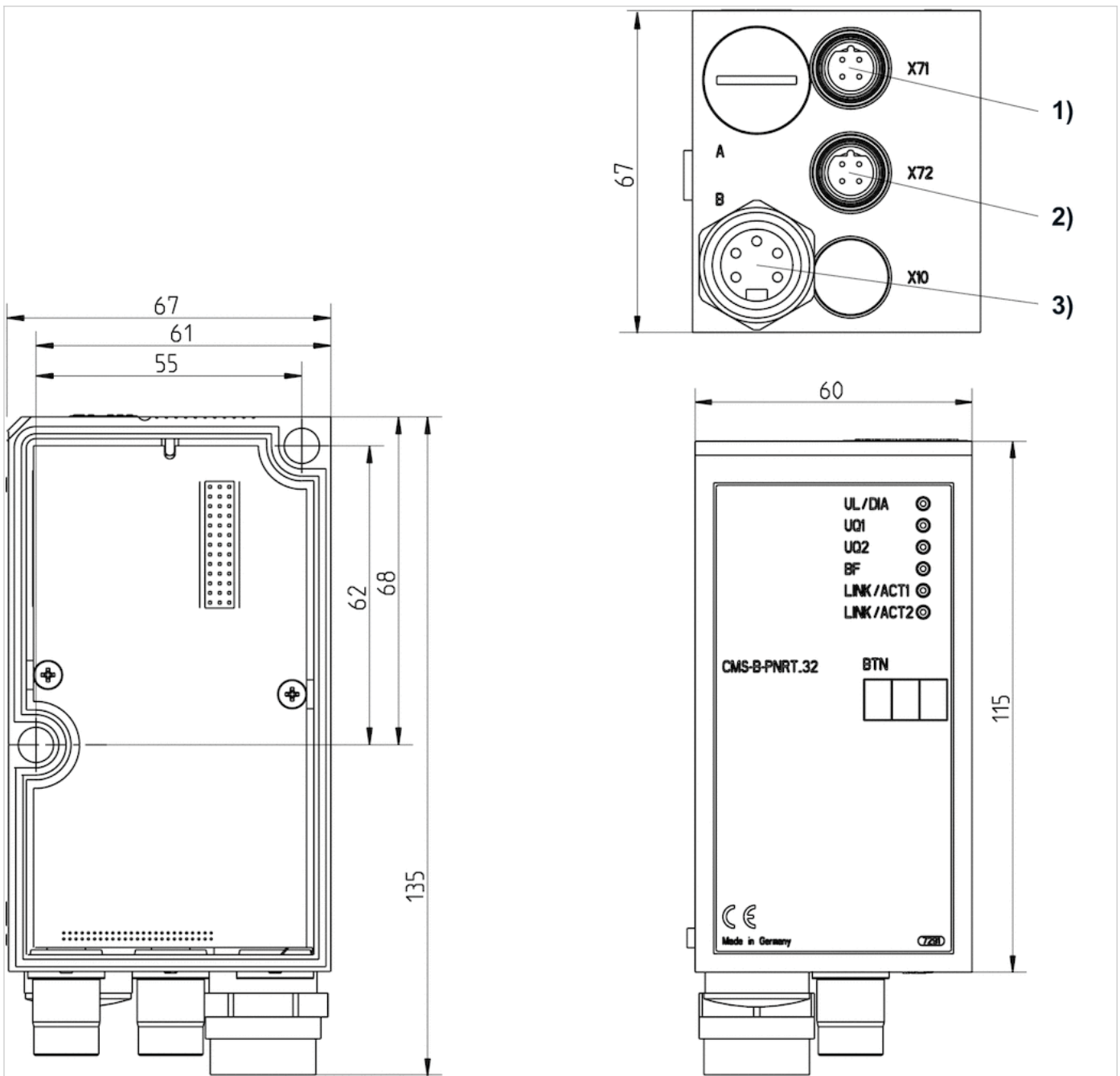

1) Bus IN 2) Bus OUT 3) Power supply

Series DDL

- B-design
- Driver
- Plug (male), M12, 5-pin, A-coded



Version	Driver
Ambient temperature min./max.	0 ... 50 °C
Operational voltage electronics	24 V DC
Power consumption electronics	0.2 A
Operating voltage, actuators	24 V DC
Actuator voltage tolerance	-10% / +10%
Total current for actuators	3 A
Protection class	IP65
Number of solenoid coils max.	24
Max. power consumption per coil	0.1 mA
Max. cable length	40 m
Max. number of DDL participants	14
Port Valve system	Socket (female), 2.0 mm strip, 3x13-pin
I/O module extension max.	6
I/O module extension Input Max.	3
I/O module extension Output Max.	3
Weight	1.04 kg

Technical data

Part No.	Port	
	1	2
R412006880	Plug (male), M12, 5-pin, A-coded	Socket (female), M12, 5-pin, A-coded

Part No.	power supply
R412006880	Plug (male), M12, 4-pin, A-coded

Scope of delivery incl. 2 tie rod extensions and seal, The following operating instructions can be found in the Media Center: R412009417 + R499050020

Technical information

Max. current in 0 V line: 4 A

You will find assignment schemes for the product in the operating instructions, or contact the nearest AVENTICS sales office.

Caution: A reduced temperature range in accordance with the operating instructions may need to be considered in ATEX applications.

Technical information

Material	
Housing	Die-cast aluminum

Dimensions

Dimensions

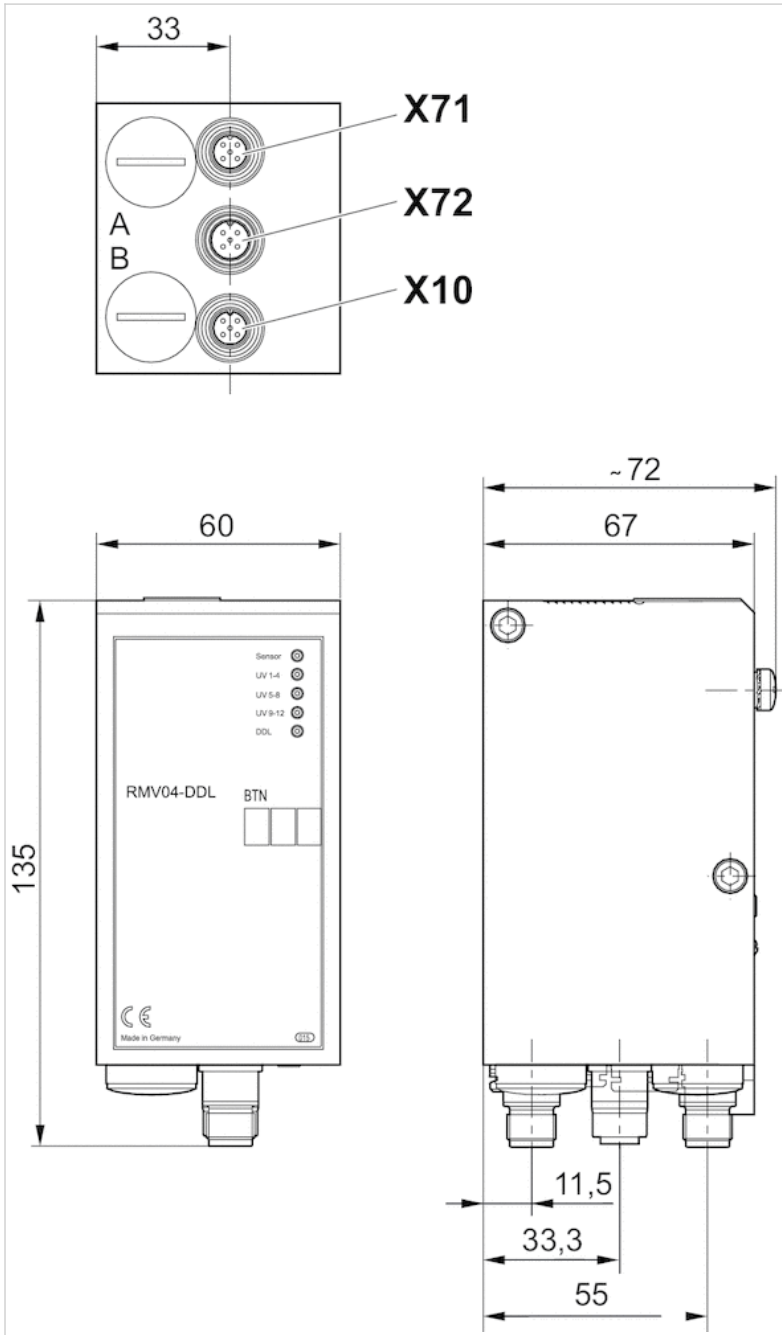

Series DDL

- B-design
- Driver
- Plug (male), M12, 5-pin, A-coded



Version	Driver
Ambient temperature min./max.	0 ... 50 °C
Operational voltage electronics	24 V DC
Power consumption electronics	0.05 A
Operating voltage, actuators	24 V DC
Actuator voltage tolerance	-10% / +10%
Total current for actuators	3 A
Protection class	IP65
Number of solenoid coils max.	32
Max. power consumption per coil	0.1 mA
Max. cable length	40 m
Max. number of DDL participants	14
Port Valve system	Socket (female), 2.0 mm strip, 2x13-pin
Weight	0.29 kg

Technical data

Part No.	Port	
	1	2
R412008541	Plug (male), M12, 5-pin, A-coded	Socket (female), M12, 5-pin, A-coded

Part No.	power supply
R412008541	Plug (male), M12, 4-pin, A-coded

Scope of delivery incl. 2 tie rod extensions and seal, The following operating instructions can be found in the Media Center: R412009417 + R499050020

Technical information

Max. current in 0 V line: 4 A

You will find assignment schemes for the product in the operating instructions, or contact the nearest AVENTICS sales office.

Caution: A reduced temperature range in accordance with the operating instructions may need to be considered in ATEX applications.

Technical information

Material	
Housing	Die-cast aluminum

Dimensions

Dimensions

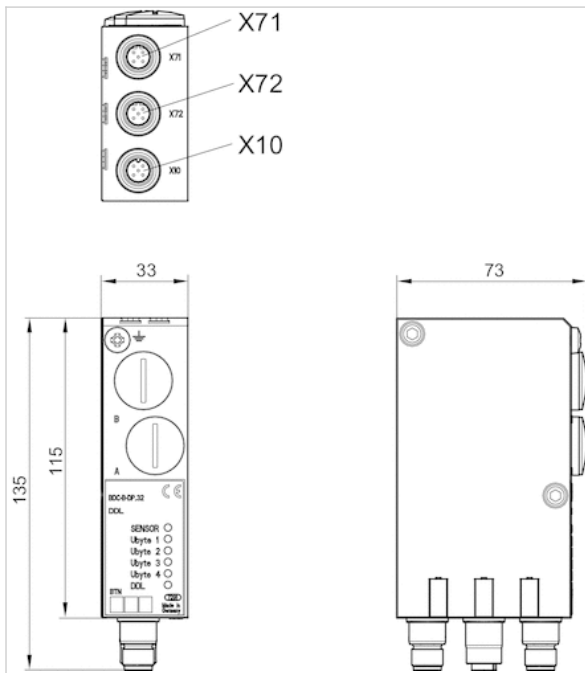

X71 = Bus IN
 X72 = Bus OUT
 X10 = power supply

Bus coupler, series AES

R412018218

General series information Series AES

- The AVENTICS Series AES fieldbus connection can be integrated into all AVENTICS fieldbus-compatible valve systems or can also be configured as a stand-alone solution. AES connects your AVENTICS valve system to all relevant fieldbus protocols and offers the integration of I/O-modules and enables optimized decentralized wiring of sensors. The integration of the Digital Twin enables users to be IIoT ready and use the AES to solve their interoperability challenges.



Technical data

Industry
Industrial

Version
Bus coupler

Fieldbus protocol
PROFIBUS DP

E/A capable
connection with I/O

Number of I/O connections
512 inputs / 512 outputs

Power plug IN type
Plug

Power plug IN size
M12x1

Power plug IN number of pole
4-pin

Power plug IN coding
A-coded

Fieldbus design
D-design

Min. ambient temperature
-10 °C

Max. ambient temperature
60 °C

Number of solenoid coils max.
128

Max. number of valve positions
64

Operational voltage electronics
24 V DC

Electronics voltage tolerance
-25% / +25%

Power consumption electronics
0.1 A

Operating voltage, actuators
24 V DC

Total current for actuators
4 A

Protection class
IP65

Cycle time at 256 bits
< 1 ms

Logic/actuator voltage
Galvanically isolated

Diagnosis	Communication port, Number of poles
Short circuit	5-pin
Undervoltage	Communication port, Coding
I/O module extension max.	B-coded
10	Communication port 2
Generic emission standard in accordance with norm	Socket
EN 61000-6-4	Communication port 2
Generic immunity standard in accordance with norm	M12x1
EN 61000-6-2	Communication port 2
Communication port Type	5-pin
Plug	Communication port 2
Communication port, Thread size	B-coded
M12x1	Weight
	0.16 kg

Material

Housing material	Part No.
Polyamide fiber-glass reinforced	R412018218

Technical information

You will find assignment schemes for the product in the operating instructions, or contact the nearest AVENTICS sales office.

Voltage and short-circuit monitoring per LED.

During cyclical data transfer, the bus coupler can send 512 bits of input data to the controller and receive 512 bits of output data from the controller.

Scope of delivery: Incl. mounting screws 3x

Dimensions

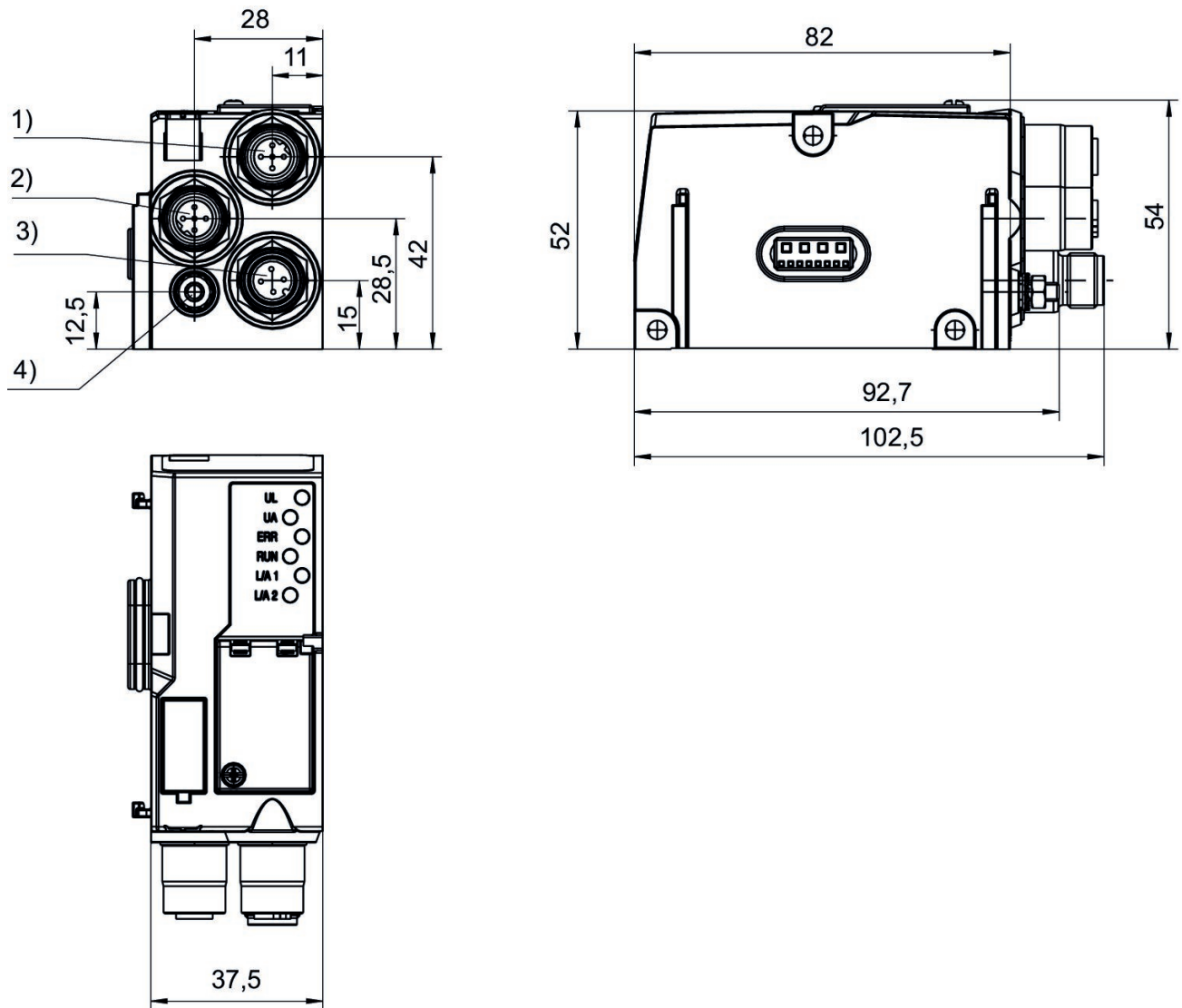

1) Fieldbus connection 2) Fieldbus connection 3) Power supply 4) Functional ground

Bus coupler, series AES

R412018220

General series information Series AES

- The AVENTICS Series AES fieldbus connection can be integrated into all AVENTICS fieldbus-compatible valve systems or can also be configured as a stand-alone solution. AES connects your AVENTICS valve system to all relevant fieldbus protocols and offers the integration of I/O-modules and enables optimized decentralized wiring of sensors. The integration of the Digital Twin enables users to be IIoT ready and use the AES to solve their interoperability challenges.



Technical data

Industry
Industrial

Version
Bus coupler

Fieldbus protocol
CANopen

E/A capable
connection with I/O

Number of I/O connections
512 inputs / 512 outputs

Power plug IN type
Plug

Power plug IN size
M12x1

Power plug IN number of pole
4-pin

Power plug IN coding
A-coded

Fieldbus design
D-design

Min. ambient temperature
-10 °C

Max. ambient temperature
60 °C

Number of solenoid coils max.
128

Max. number of valve positions
64

Operational voltage electronics
24 V DC

Electronics voltage tolerance
-25% / +25%

Power consumption electronics
0.1 A

Operating voltage, actuators
24 V DC

Total current for actuators
4 A

Protection class
IP65

Cycle time at 256 bits
< 1 ms

Logic/actuator voltage
Galvanically isolated

Diagnosis	Communication port, Number of poles
Short circuit	5-pin
Undervoltage	Communication port, Coding
I/O module extension max.	A-coded
10	Communication port 2
Generic emission standard in accordance with norm	Socket
EN 61000-6-4	Communication port 2
Generic immunity standard in accordance with norm	M12x1
EN 61000-6-2	Communication port 2
Communication port Type	5-pin
Plug	Communication port 2
Communication port, Thread size	A-coded
M12x1	Weight
	0.16 kg

Material

Housing material	Part No.
Polyamide fiber-glass reinforced	R412018220

Technical information

You will find assignment schemes for the product in the operating instructions, or contact the nearest AVENTICS sales office.

Voltage and short-circuit monitoring per LED.

During cyclical data transfer, the bus coupler can send 512 bits of input data to the controller and receive 512 bits of output data from the controller.

Scope of delivery: Incl. mounting screws 3x

Dimensions

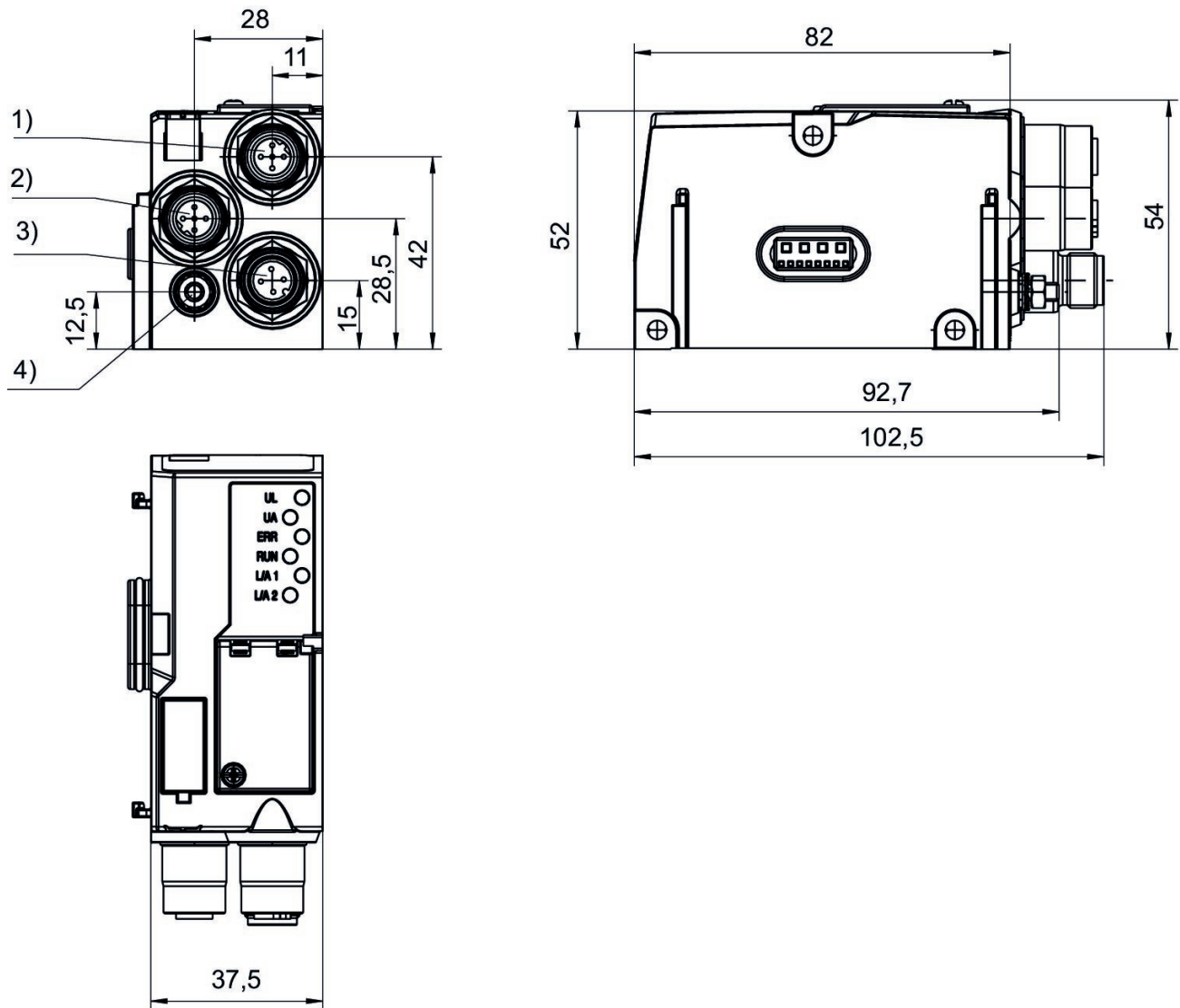

1) Fieldbus connection 2) Fieldbus connection 3) Power supply 4) Functional ground

Bus coupler, series AES

R412018221

General series information Series AES

- The AVENTICS Series AES fieldbus connection can be integrated into all AVENTICS fieldbus-compatible valve systems or can also be configured as a stand-alone solution. AES connects your AVENTICS valve system to all relevant fieldbus protocols and offers the integration of I/O-modules and enables optimized decentralized wiring of sensors. The integration of the Digital Twin enables users to be IIoT ready and use the AES to solve their interoperability challenges.



Technical data

Industry
Industrial

Version
Bus coupler

Fieldbus protocol
DeviceNet

E/A capable
connection with I/O

Number of I/O connections
512 inputs / 512 outputs

Power plug IN type
Plug

Power plug IN size
M12x1

Power plug IN number of pole
4-pin

Power plug IN coding
A-coded

Fieldbus design
D-design

Min. ambient temperature
-10 °C

Max. ambient temperature
60 °C

Number of solenoid coils max.
128

Max. number of valve positions
64

Operational voltage electronics
24 V DC

Electronics voltage tolerance
-25% / +25%

Power consumption electronics
0.1 A

Operating voltage, actuators
24 V DC

Total current for actuators
4 A

Protection class
IP65

Cycle time at 256 bits
< 1 ms

Logic/actuator voltage
Galvanically isolated

Diagnosis	Communication port, Number of poles
Short circuit	5-pin
Undervoltage	Communication port, Coding
I/O module extension max.	A-coded
10	Communication port 2
Generic emission standard in accordance with norm	Socket
EN 61000-6-4	Communication port 2
Generic immunity standard in accordance with norm	M12x1
EN 61000-6-2	Communication port 2
Communication port Type	5-pin
Plug	Communication port 2
Communication port, Thread size	A-coded
M12x1	Weight
	0.16 kg

Material

Housing material	Part No.
Polyamide fiber-glass reinforced	R412018221

Technical information

You will find assignment schemes for the product in the operating instructions, or contact the nearest AVENTICS sales office.

Voltage and short-circuit monitoring per LED.

During cyclical data transfer, the bus coupler can send 512 bits of input data to the controller and receive 512 bits of output data from the controller.

Scope of delivery: Incl. mounting screws 3x

Dimensions

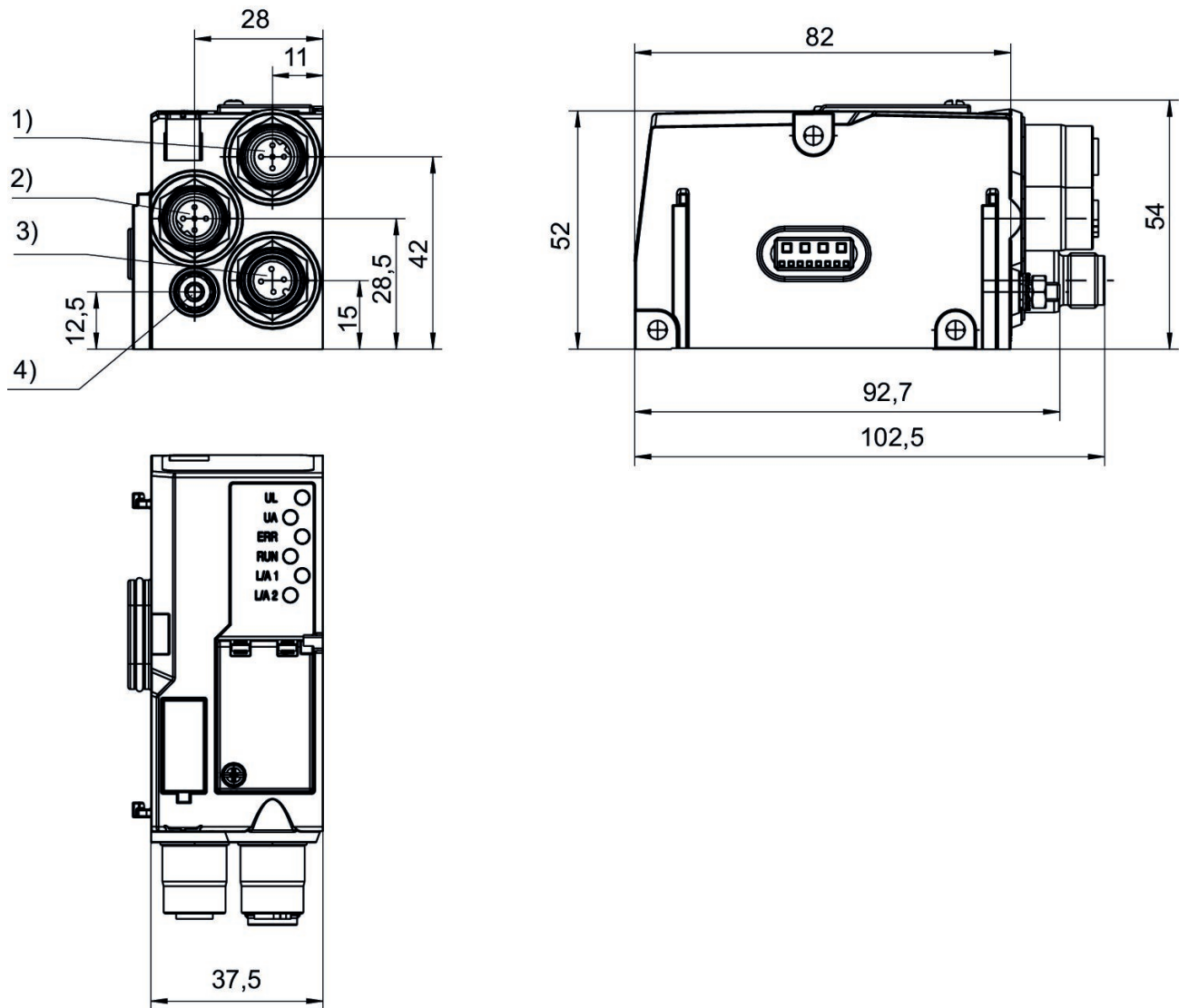

1) Fieldbus connection 2) Fieldbus connection 3) Power supply 4) Functional ground

Bus coupler, series AES

R412088222

General series information Series AES

- The AVENTICS Series AES fieldbus connection can be integrated into all AVENTICS fieldbus-compatible valve systems or can also be configured as a stand-alone solution. AES connects your AVENTICS valve system to all relevant fieldbus protocols and offers the integration of I/O-modules and enables optimized decentralized wiring of sensors. The integration of the Digital Twin enables users to be IIoT ready and use the AES to solve their interoperability challenges.



Technical data

Industry
Industrial

Version
Bus coupler

Type
Generation 2
Note: supports DLR

Fieldbus protocol
EtherNet/IP

E/A capable
connection with I/O

Number of I/O connections
512 inputs / 512 outputs

Power plug IN type
Plug

Power plug IN size
M12x1

Power plug IN number of pole
4-pin

Power plug IN coding
A-coded

Fieldbus design
D-design

Min. ambient temperature
-10 °C

Max. ambient temperature
60 °C

Number of solenoid coils max.
128

Max. number of valve positions
64

Operational voltage electronics
24 V DC

Electronics voltage tolerance
-25% / +25%

Power consumption electronics
0.1 A

Operating voltage, actuators
24 V DC

Total current for actuators
4 A

Protection class
IP65

Cycle time at 256 bits
< 1 ms

Logic/actuator voltage
Galvanically isolated

Diagnosis
System error
Undervoltage

I/O module extension max.
10

Generic emission standard in accordance with
norm
EN 61000-6-4

Generic immunity standard in accordance with
norm
EN 61000-6-2

Communication port Type
Socket

Communication port, Thread size
M12x1

Communication port, Number of poles
4-pin

Communication port, Coding
D-coded

Communication port 2
Socket

Communication port 2
M12x1

Communication port 2
4-pin

Communication port 2
D-coded

Weight
0.175 kg

Material

Housing material
Polyamide fiber-glass reinforced

Part No.
R412088222

Technical information

You will find assignment schemes for the product in the operating instructions, or contact the nearest AVENTICS sales office.

Voltage and short-circuit monitoring per LED.

During cyclical data transfer, the bus coupler can send 512 bits of input data to the controller and receive 512 bits of output data from the controller.

Scope of delivery: Incl. mounting screws 3x

Dimensions

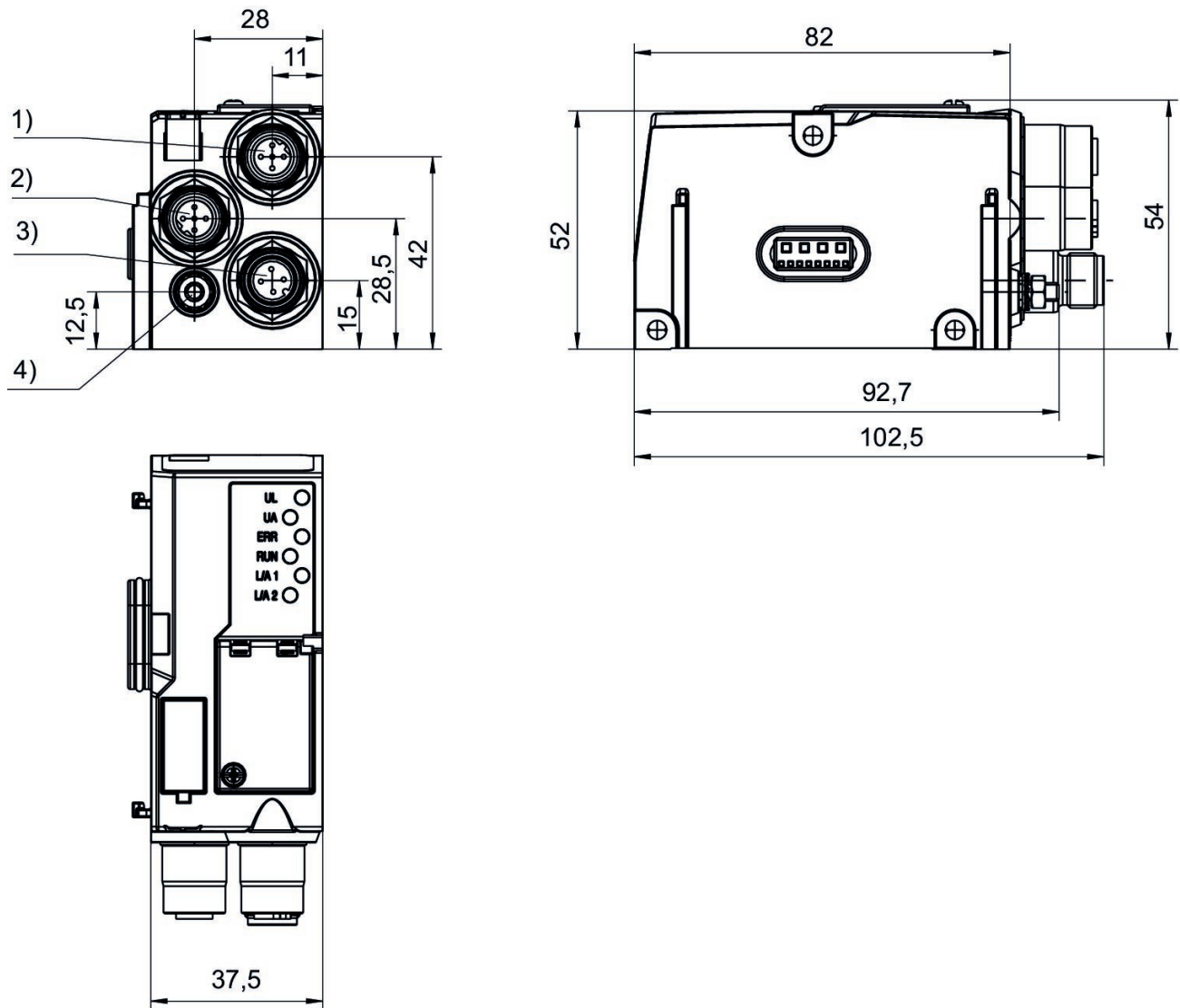

1) Fieldbus connection 2) Fieldbus connection 3) Power supply 4) Functional ground

Bus coupler, series AES

R412018222

General series information Series AES

- The AVENTICS Series AES fieldbus connection can be integrated into all AVENTICS fieldbus-compatible valve systems or can also be configured as a stand-alone solution. AES connects your AVENTICS valve system to all relevant fieldbus protocols and offers the integration of I/O-modules and enables optimized decentralized wiring of sensors. The integration of the Digital Twin enables users to be IIoT ready and use the AES to solve their interoperability challenges.



Technical data

Industry
Industrial

Version
Bus coupler

Note
Do not use in new constructions!

Fieldbus protocol
EtherNet/IP

E/A capable
connection with I/O

Number of I/O connections
512 inputs / 512 outputs

Power plug IN type
Plug

Power plug IN size
M12x1

Power plug IN number of pole
4-pin

Power plug IN coding
A-coded

Fieldbus design
D-design

Min. ambient temperature
-10 °C

Max. ambient temperature
60 °C

Number of solenoid coils max.
128

Max. number of valve positions
64

Operational voltage electronics
24 V DC

Electronics voltage tolerance
-25% / +25%

Power consumption electronics
0.1 A

Operating voltage, actuators
24 V DC

Total current for actuators
4 A

Protection class
IP65

Cycle time at 256 bits
< 1 ms

Logic/actuator voltage
Galvanically isolated

Diagnosis
System error
Undervoltage

I/O module extension max.
10

Generic emission standard in accordance with
norm
EN 61000-6-4

Generic immunity standard in accordance with
norm
EN 61000-6-2

Communication port Type
Socket

Communication port, Thread size
M12x1

Communication port, Number of poles
4-pin

Communication port, Coding
D-coded

Communication port 2
Socket

Communication port 2
M12x1

Communication port 2
4-pin

Communication port 2
D-coded

Weight
0.175 kg

Material

Housing material
Polyamide fiber-glass reinforced

Part No.
R412018222

Technical information

You will find assignment schemes for the product in the operating instructions, or contact the nearest AVENTICS sales office.

Voltage and short-circuit monitoring per LED.

During cyclical data transfer, the bus coupler can send 512 bits of input data to the controller and receive 512 bits of output data from the controller.

Scope of delivery: Incl. mounting screws 3x

Dimensions

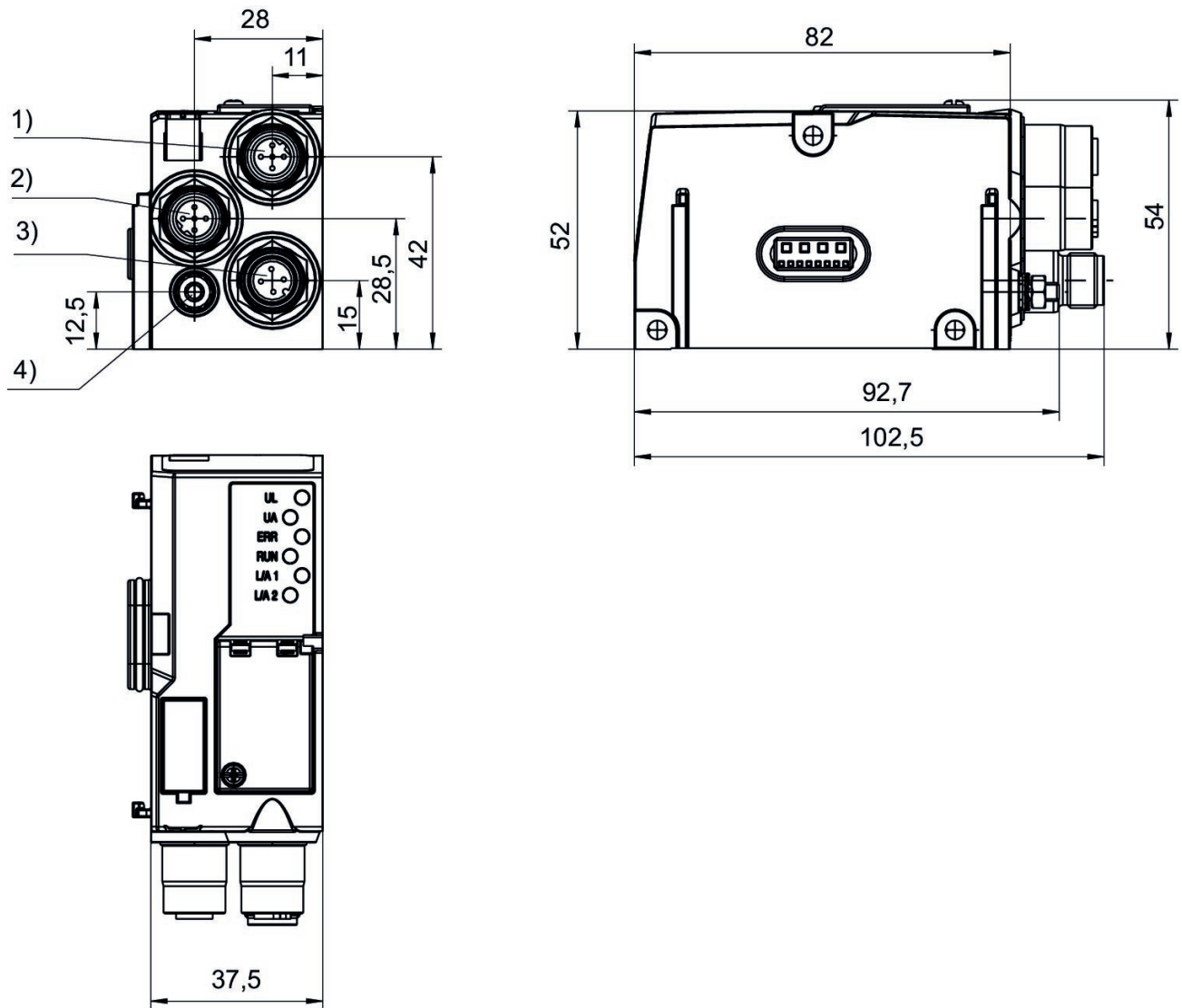

1) Fieldbus connection 2) Fieldbus connection 3) Power supply 4) Functional ground

Bus coupler, series AES

R412088223

General series information Series AES

- The AVENTICS Series AES fieldbus connection can be integrated into all AVENTICS fieldbus-compatible valve systems or can also be configured as a stand-alone solution. AES connects your AVENTICS valve system to all relevant fieldbus protocols and offers the integration of I/O-modules and enables optimized decentralized wiring of sensors. The integration of the Digital Twin enables users to be IIoT ready and use the AES to solve their interoperability challenges.



Technical data

Industry
Industrial

Version
Bus coupler

Type
Generation 2
Note: supports MRP and IRT (RT_CLASS 3)

Fieldbus protocol
PROFINET IO

E/A capable
connection with I/O

Number of I/O connections
512 inputs / 512 outputs

Power plug IN type
Plug

Power plug IN size
M12x1

Power plug IN number of pole
4-pin

Power plug IN coding
A-coded

Fieldbus design
D-design

Min. ambient temperature
-10 °C

Max. ambient temperature
60 °C

Number of solenoid coils max.
128

Max. number of valve positions
64

Operational voltage electronics
24 V DC

Electronics voltage tolerance
-25% / +25%

Power consumption electronics
0.1 A

Operating voltage, actuators
24 V DC

Total current for actuators
4 A

Protection class
IP65

Cycle time at 256 bits
< 1 ms

Logic/actuator voltage
Galvanically isolated

Diagnosis
System error
Undervoltage

I/O module extension max.
10

Generic emission standard in accordance with
norm
EN 61000-6-4

Generic immunity standard in accordance with
norm
EN 61000-6-2

Communication port Type
Socket

Communication port, Thread size
M12x1

Communication port, Number of poles
4-pin

Communication port, Coding
D-coded

Communication port 2
Socket

Communication port 2
M12x1

Communication port 2
4-pin

Communication port 2
D-coded

Weight
0.175 kg

Material

Housing material
Polyamide fiber-glass reinforced

Part No.
R412088223

Technical information

You will find assignment schemes for the product in the operating instructions, or contact the nearest AVENTICS sales office.

Voltage and short-circuit monitoring per LED.

During cyclical data transfer, the bus coupler can send 512 bits of input data to the controller and receive 512 bits of output data from the controller.

Scope of delivery: Incl. mounting screws 3x

Dimensions

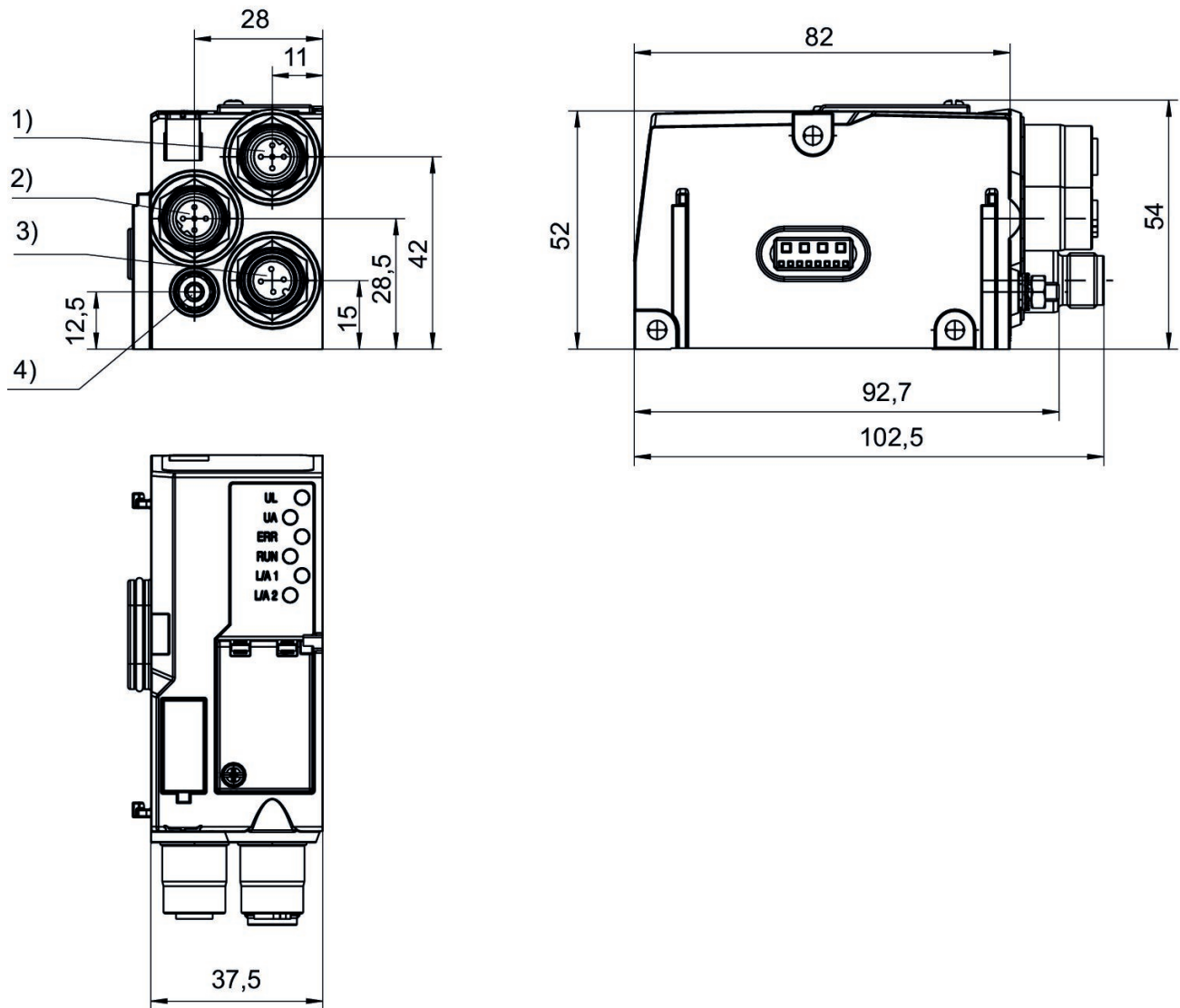

1) Fieldbus connection 2) Fieldbus connection 3) Power supply 4) Functional ground

Bus coupler, series AES

R412018223

General series information Series AES

- The AVENTICS Series AES fieldbus connection can be integrated into all AVENTICS fieldbus-compatible valve systems or can also be configured as a stand-alone solution. AES connects your AVENTICS valve system to all relevant fieldbus protocols and offers the integration of I/O-modules and enables optimized decentralized wiring of sensors. The integration of the Digital Twin enables users to be IIoT ready and use the AES to solve their interoperability challenges.



Technical data

Industry
Industrial

Version
Bus coupler

Note
Do not use in new constructions!

Fieldbus protocol
PROFINET IO

E/A capable
connection with I/O

Number of I/O connections
512 inputs / 512 outputs

Power plug IN type
Plug

Power plug IN size
M12x1

Power plug IN number of pole
4-pin

Power plug IN coding
A-coded

Fieldbus design
D-design

Min. ambient temperature
-10 °C

Max. ambient temperature
60 °C

Number of solenoid coils max.
128

Max. number of valve positions
64

Operational voltage electronics
24 V DC

Electronics voltage tolerance
-25% / +25%

Power consumption electronics
0.1 A

Operating voltage, actuators
24 V DC

Total current for actuators
4 A

Protection class
IP65

Cycle time at 256 bits
< 1 ms

Logic/actuator voltage
Galvanically isolated

Diagnosis
System error
Undervoltage

I/O module extension max.
10

Generic emission standard in accordance with
norm
EN 61000-6-4

Generic immunity standard in accordance with
norm
EN 61000-6-2

Communication port Type
Socket

Communication port, Thread size
M12x1

Communication port, Number of poles
4-pin

Communication port, Coding
D-coded

Communication port 2
Socket

Communication port 2
M12x1

Communication port 2
4-pin

Communication port 2
D-coded

Weight
0.175 kg

Material

Housing material
Polyamide fiber-glass reinforced

Part No.
R412018223

Technical information

You will find assignment schemes for the product in the operating instructions, or contact the nearest AVENTICS sales office.

Voltage and short-circuit monitoring per LED.

During cyclical data transfer, the bus coupler can send 512 bits of input data to the controller and receive 512 bits of output data from the controller.

Scope of delivery: Incl. mounting screws 3x

Dimensions

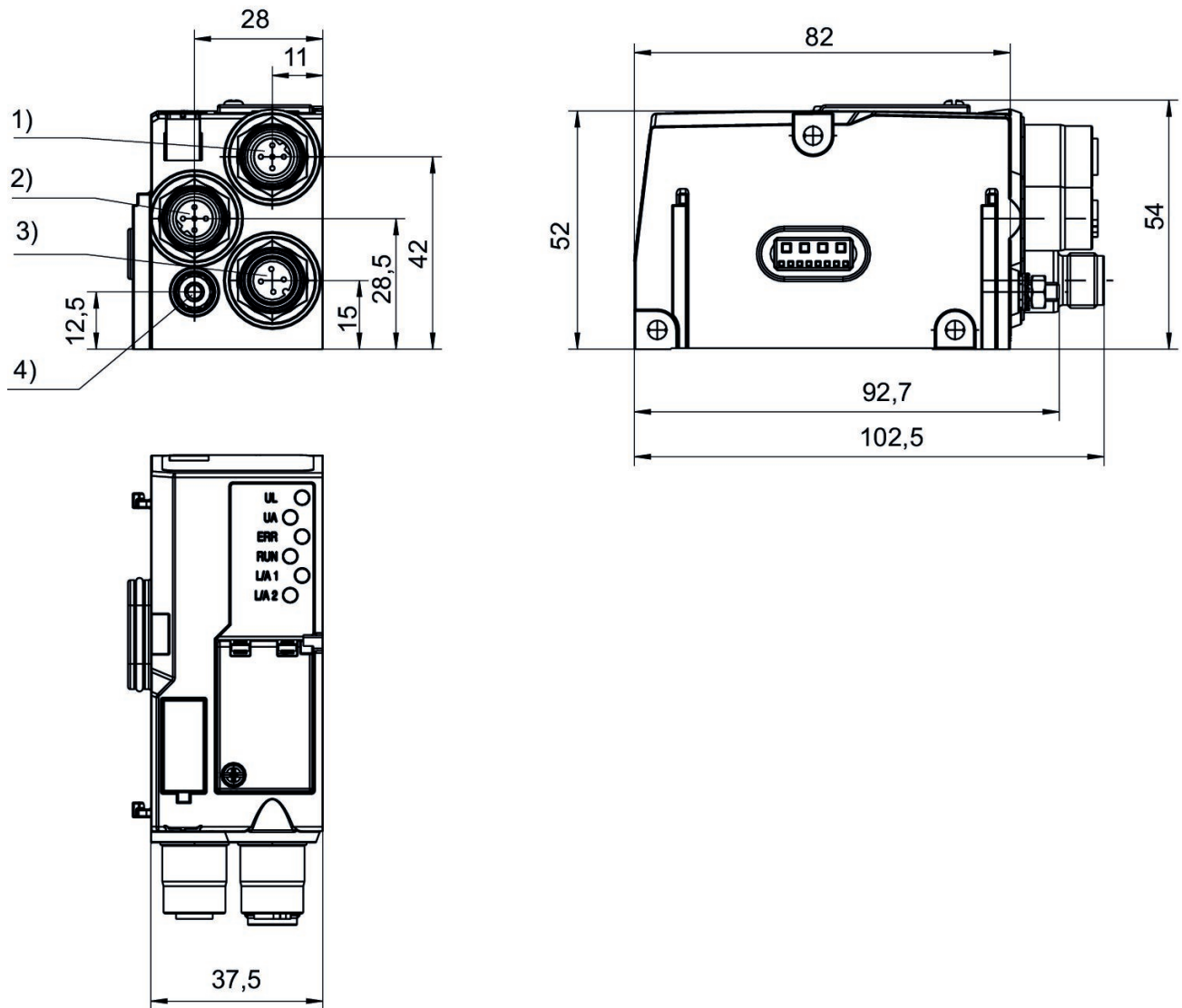

1) Fieldbus connection 2) Fieldbus connection 3) Power supply 4) Functional ground

Bus coupler, series AES

R412088225

General series information Series AES

- The AVENTICS Series AES fieldbus connection can be integrated into all AVENTICS fieldbus-compatible valve systems or can also be configured as a stand-alone solution. AES connects your AVENTICS valve system to all relevant fieldbus protocols and offers the integration of I/O-modules and enables optimized decentralized wiring of sensors. The integration of the Digital Twin enables users to be IIoT ready and use the AES to solve their interoperability challenges.



Technical data

Industry
Industrial

Version
Bus coupler

Type
Generation 2

Fieldbus protocol
EtherCAT

E/A capable
connection with I/O

Number of I/O connections
512 inputs / 512 outputs

Power plug IN type
Plug

Power plug IN size
M12x1

Power plug IN number of pole
4-pin

Power plug IN coding
A-coded

Fieldbus design
D-design

Min. ambient temperature
-10 °C

Max. ambient temperature
60 °C

Number of solenoid coils max.
128

Max. number of valve positions
64

Operational voltage electronics
24 V DC

Electronics voltage tolerance
-25% / +25%

Power consumption electronics
0.1 A

Operating voltage, actuators
24 V DC

Total current for actuators
4 A

Protection class
IP65

Cycle time at 256 bits
< 1 ms

Logic/actuator voltage
Galvanically isolated

Diagnosis
System error
Undervoltage

I/O module extension max.
10

Generic emission standard in accordance with
norm
EN 61000-6-4

Generic immunity standard in accordance with
norm
EN 61000-6-2

Communication port Type
Socket

Communication port, Thread size
M12x1

Communication port, Number of poles
4-pin

Communication port, Coding
D-coded

Communication port 2
Socket

Communication port 2
M12x1

Communication port 2
4-pin

Communication port 2
D-coded

Weight
0.175 kg

Material

Housing material
Polyamide fiber-glass reinforced

Part No.
R412088225

Technical information

You will find assignment schemes for the product in the operating instructions, or contact the nearest AVENTICS sales office.

Voltage and short-circuit monitoring per LED.

During cyclical data transfer, the bus coupler can send 512 bits of input data to the controller and receive 512 bits of output data from the controller.

Scope of delivery: Incl. mounting screws 3x

Dimensions

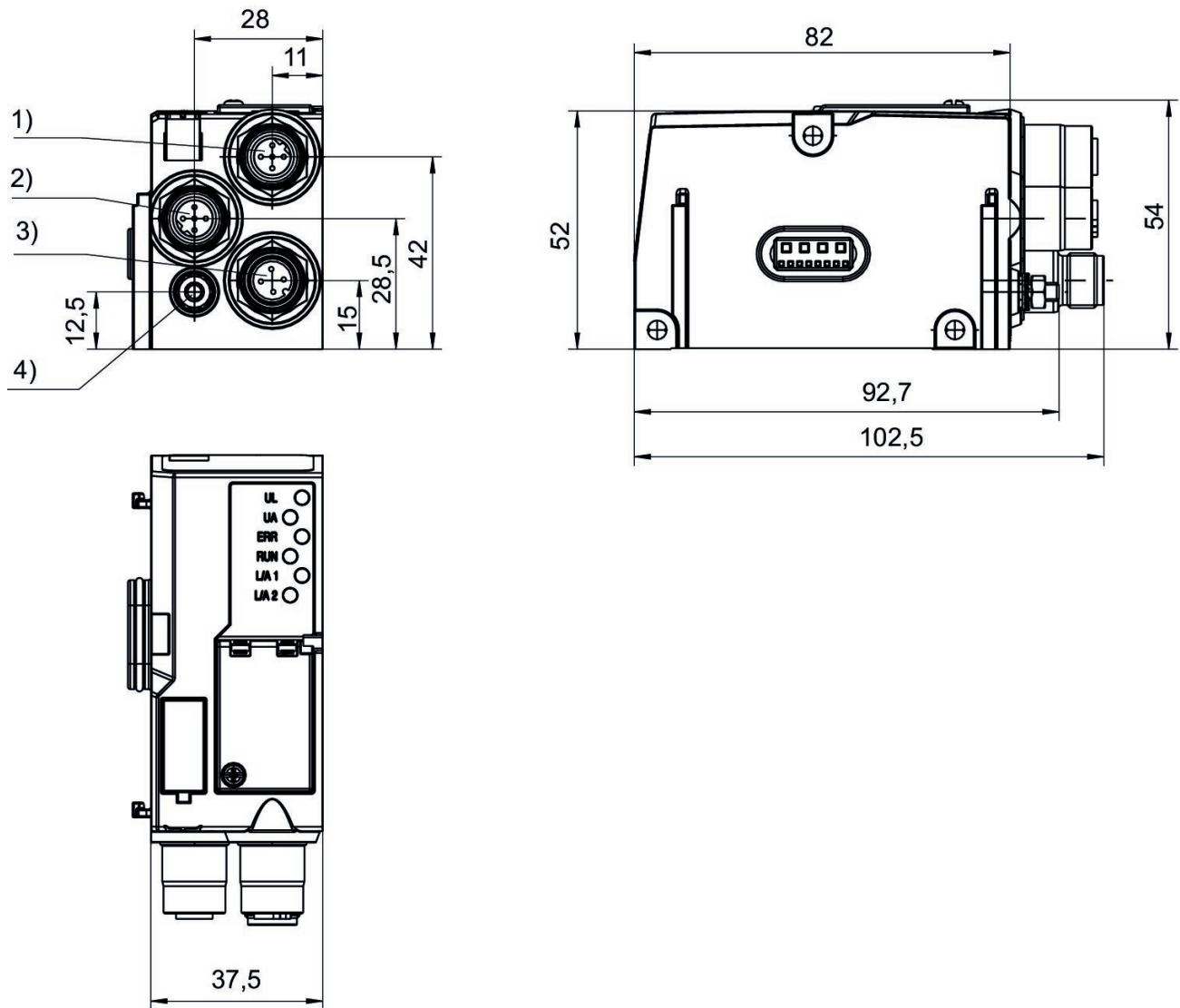

1) Fieldbus connection 2) Fieldbus connection 3) Power supply 4) Functional ground

Bus coupler, series AES

R412018225

General series information Series AES

- The AVENTICS Series AES fieldbus connection can be integrated into all AVENTICS fieldbus-compatible valve systems or can also be configured as a stand-alone solution. AES connects your AVENTICS valve system to all relevant fieldbus protocols and offers the integration of I/O-modules and enables optimized decentralized wiring of sensors. The integration of the Digital Twin enables users to be IIoT ready and use the AES to solve their interoperability challenges.



Technical data

Industry
Industrial

Version
Bus coupler

Note
Do not use in new constructions!

Fieldbus protocol
EtherCAT

E/A capable
connection with I/O

Number of I/O connections
512 inputs / 512 outputs

Power plug IN type
Plug

Power plug IN size
M12x1

Power plug IN number of pole
4-pin

Power plug IN coding
A-coded

Fieldbus design
D-design

Min. ambient temperature
-10 °C

Max. ambient temperature
60 °C

Number of solenoid coils max.
128

Max. number of valve positions
64

Operational voltage electronics
24 V DC

Electronics voltage tolerance
-25% / +25%

Power consumption electronics
0.1 A

Operating voltage, actuators
24 V DC

Total current for actuators
4 A

Protection class
IP65

Cycle time at 256 bits
< 1 ms

Logic/actuator voltage
Galvanically isolated

Diagnosis
System error
Undervoltage

I/O module extension max.
10

Generic emission standard in accordance with
norm
EN 61000-6-4

Generic immunity standard in accordance with
norm
EN 61000-6-2

Communication port Type
Socket

Communication port, Thread size
M12x1

Communication port, Number of poles
4-pin

Communication port, Coding
D-coded

Communication port 2
Socket

Communication port 2
M12x1

Communication port 2
4-pin

Communication port 2
D-coded

Weight
0.175 kg

Material

Housing material
Polyamide fiber-glass reinforced

Part No.
R412018225

Technical information

You will find assignment schemes for the product in the operating instructions, or contact the nearest AVENTICS sales office.

Voltage and short-circuit monitoring per LED.

During cyclical data transfer, the bus coupler can send 512 bits of input data to the controller and receive 512 bits of output data from the controller.

Scope of delivery: Incl. mounting screws 3x

Dimensions

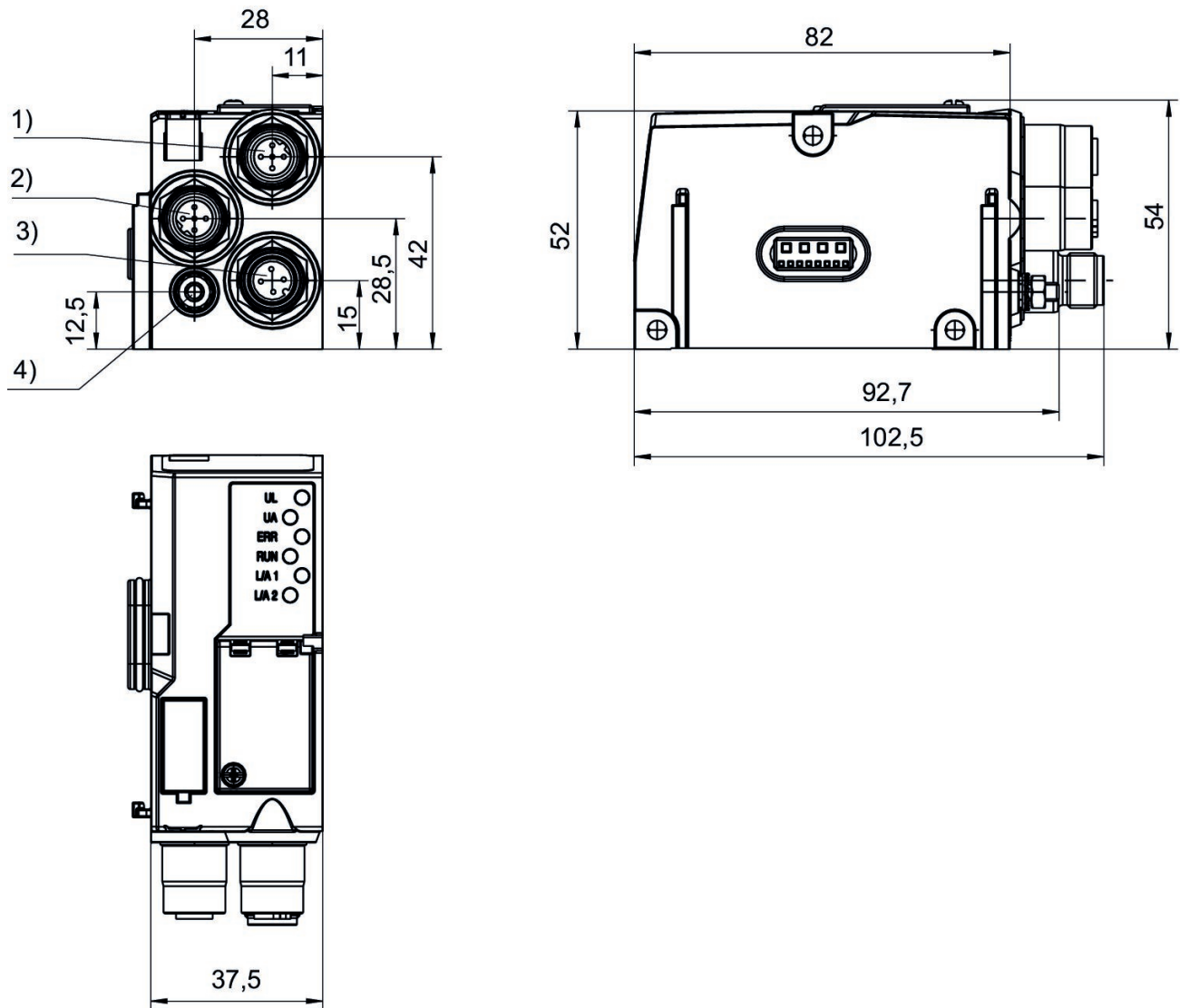

1) Fieldbus connection 2) Fieldbus connection 3) Power supply 4) Functional ground

Bus coupler, series AES

R412088226

General series information Series AES

- The AVENTICS Series AES fieldbus connection can be integrated into all AVENTICS fieldbus-compatible valve systems or can also be configured as a stand-alone solution. AES connects your AVENTICS valve system to all relevant fieldbus protocols and offers the integration of I/O-modules and enables optimized decentralized wiring of sensors. The integration of the Digital Twin enables users to be IIoT ready and use the AES to solve their interoperability challenges.



Technical data

Industry
Industrial

Version
Bus coupler

Type
Generation 2

Fieldbus protocol
POWERLINK

E/A capable
connection with I/O

Number of I/O connections
512 inputs / 512 outputs

Power plug IN type
Plug

Power plug IN size
M12x1

Power plug IN number of pole
4-pin

Power plug IN coding
A-coded

Fieldbus design
D-design

Min. ambient temperature
-10 °C

Max. ambient temperature
60 °C

Number of solenoid coils max.
128

Max. number of valve positions
64

Operational voltage electronics
24 V DC

Electronics voltage tolerance
-25% / +25%

Power consumption electronics
0.1 A

Operating voltage, actuators
24 V DC

Total current for actuators
4 A

Protection class
IP65

Cycle time at 256 bits
< 1 ms

Logic/actuator voltage

Galvanically isolated

Diagnosis

System error

Undervoltage

I/O module extension max.

10

Generic emission standard in accordance with norm

EN 61000-6-4

Generic immunity standard in accordance with norm

EN 61000-6-2

Communication port Type

Socket

Communication port, Thread size

M12x1

Communication port, Number of poles

4-pin

Communication port, Coding

D-coded

Communication port 2

Socket

Communication port 2

M12x1

Communication port 2

4-pin

Communication port 2

D-coded

Weight

0.175 kg

Material

Housing material

Polyamide fiber-glass reinforced

Part No.

R412088226

Technical information

You will find assignment schemes for the product in the operating instructions, or contact the nearest AVENTICS sales office.

Voltage and short-circuit monitoring per LED.

During cyclical data transfer, the bus coupler can send 512 bits of input data to the controller and receive 512 bits of output data from the controller.

Scope of delivery: Incl. mounting screws 3x

Dimensions

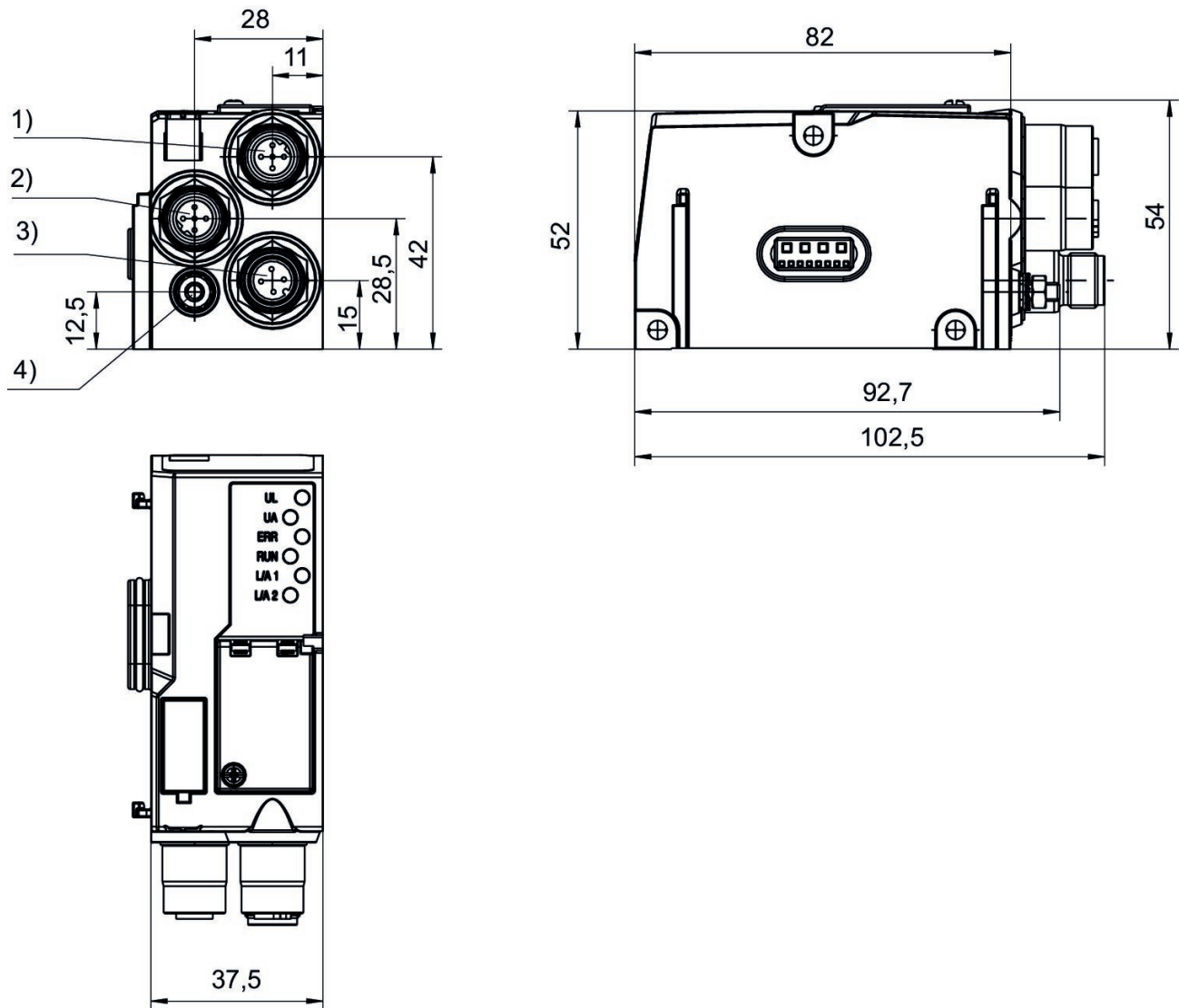

1) Fieldbus connection 2) Fieldbus connection 3) Power supply 4) Functional ground

Bus coupler, series AES

R412018226

General series information Series AES

- The AVENTICS Series AES fieldbus connection can be integrated into all AVENTICS fieldbus-compatible valve systems or can also be configured as a stand-alone solution. AES connects your AVENTICS valve system to all relevant fieldbus protocols and offers the integration of I/O-modules and enables optimized decentralized wiring of sensors. The integration of the Digital Twin enables users to be IIoT ready and use the AES to solve their interoperability challenges.



Technical data

Industry
Industrial

Version
Bus coupler

Note
Do not use in new constructions!

Fieldbus protocol
POWERLINK

E/A capable
connection with I/O

Number of I/O connections
512 inputs / 512 outputs

Power plug IN type
Plug

Power plug IN size
M12x1

Power plug IN number of pole
4-pin

Power plug IN coding
A-coded

Fieldbus design
D-design

Min. ambient temperature
-10 °C

Max. ambient temperature
60 °C

Number of solenoid coils max.
128

Max. number of valve positions
64

Operational voltage electronics
24 V DC

Electronics voltage tolerance
-25% / +25%

Power consumption electronics
0.1 A

Operating voltage, actuators
24 V DC

Total current for actuators
4 A

Protection class
IP65

Cycle time at 256 bits
< 1 ms

Logic/actuator voltage
Galvanically isolated

Diagnosis
System error
Undervoltage

I/O module extension max.
10

Generic emission standard in accordance with
norm
EN 61000-6-4

Generic immunity standard in accordance with
norm
EN 61000-6-2

Communication port Type
Socket

Communication port, Thread size
M12x1

Communication port, Number of poles
4-pin

Communication port, Coding
D-coded

Communication port 2
Socket

Communication port 2
M12x1

Communication port 2
4-pin

Communication port 2
D-coded

Weight
0.175 kg

Material

Housing material
Polyamide fiber-glass reinforced

Part No.
R412018226

Technical information

You will find assignment schemes for the product in the operating instructions, or contact the nearest AVENTICS sales office.

Voltage and short-circuit monitoring per LED.

During cyclical data transfer, the bus coupler can send 512 bits of input data to the controller and receive 512 bits of output data from the controller.

Scope of delivery: Incl. mounting screws 3x

Dimensions

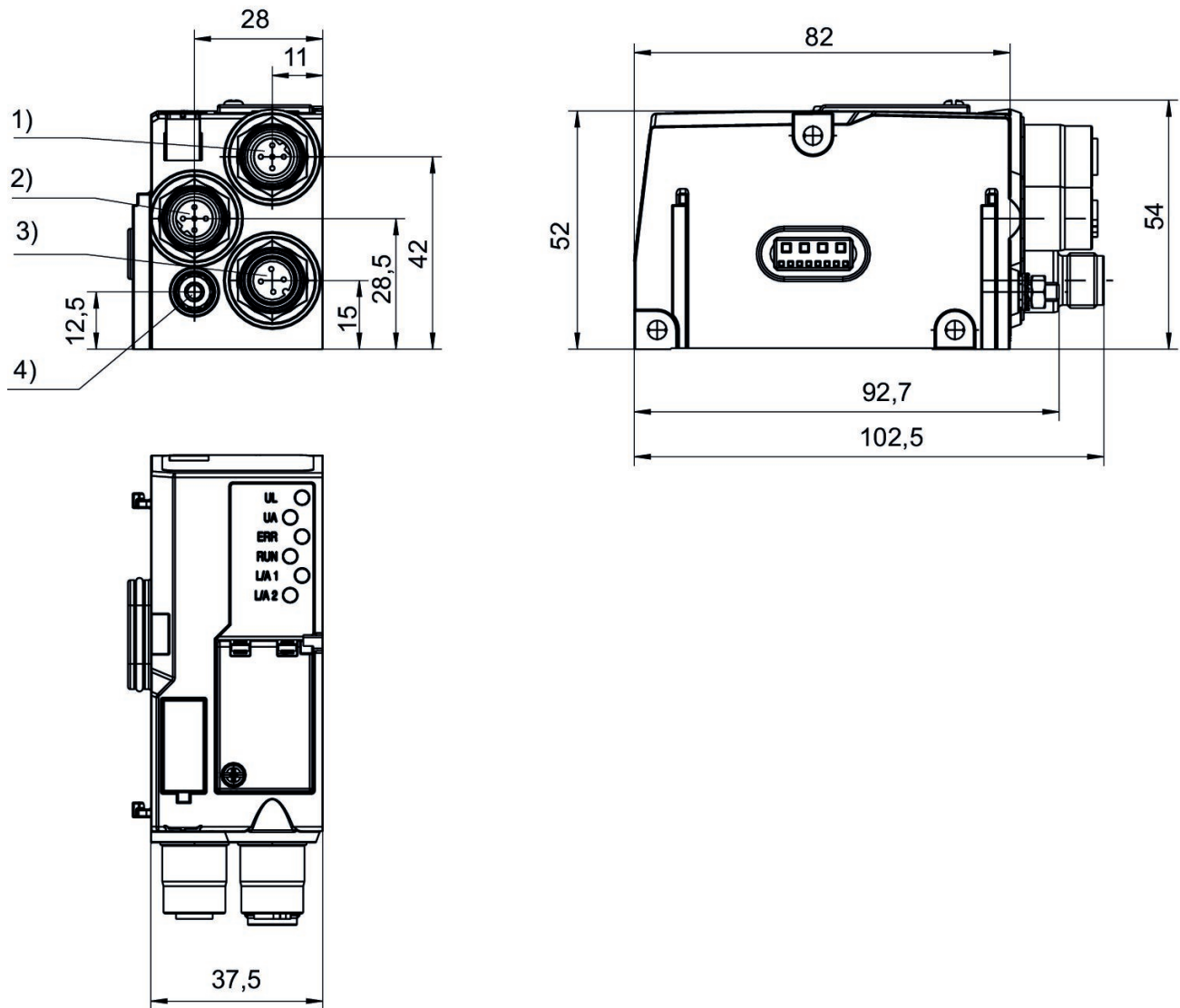

1) Fieldbus connection 2) Fieldbus connection 3) Power supply 4) Functional ground

Bus coupler, series AES

R412088227

General series information

Series AES

- The AVENTICS Series AES fieldbus connection can be integrated into all AVENTICS fieldbus-compatible valve systems or can also be configured as a stand-alone solution. AES connects your AVENTICS valve system to all relevant fieldbus protocols and offers the integration of I/O-modules and enables optimized decentralized wiring of sensors. The integration of the Digital Twin enables users to be IIoT ready and use the AES to solve their interoperability challenges.



Technical data

Industry

Industrial

Version

Bus coupler

Type

Generation 2

Fieldbus protocol

MODBUS TCP

E/A capable

connection with I/O

Number of I/O connections

512 inputs / 512 outputs

Power plug IN type

Plug

Power plug IN size

M12x1

Power plug IN number of pole

4-pin

Power plug IN coding

A-coded

Fieldbus design

D-design

Min. ambient temperature

-10 °C

Max. ambient temperature

60 °C

Number of solenoid coils max.

128

Max. number of valve positions

64

Operational voltage electronics

24 V DC

Electronics voltage tolerance

-25% / +25%

Power consumption electronics

0.1 A

Operating voltage, actuators

24 V DC

Total current for actuators

4 A

Protection class

IP65

Cycle time at 256 bits

< 1 ms

Logic/actuator voltage
Galvanically isolated

Diagnosis
System error
Undervoltage

I/O module extension max.
10

Generic emission standard in accordance with
norm
EN 61000-6-4

Generic immunity standard in accordance with
norm
EN 61000-6-2

Communication port Type
Socket

Communication port, Thread size
M12x1

Communication port, Number of poles
4-pin

Communication port, Coding
D-coded

Communication port 2
Socket

Communication port 2
M12x1

Communication port 2
4-pin

Communication port 2
D-coded

Weight
0.175 kg

Material

Housing material
Polyamide fiber-glass reinforced

Part No.
R412088227

Technical information

You will find assignment schemes for the product in the operating instructions, or contact the nearest AVENTICS sales office.

Voltage and short-circuit monitoring per LED.

During cyclical data transfer, the bus coupler can send 512 bits of input data to the controller and receive 512 bits of output data from the controller.

Scope of delivery: Incl. mounting screws 3x

Dimensions

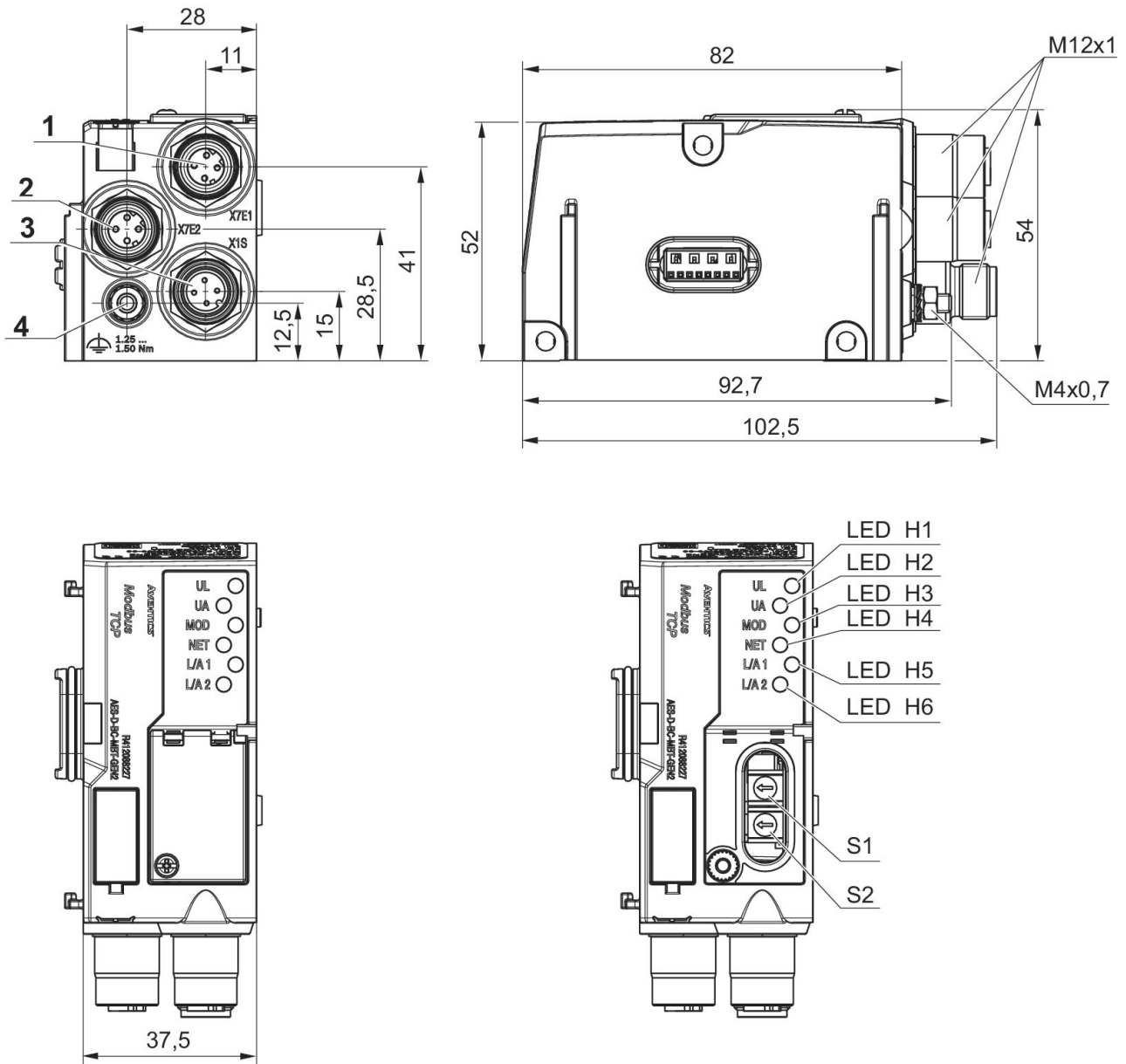

1) Fieldbus connection 2) Fieldbus connection 3) Power supply 4) Functional ground

Pin assignment, socket

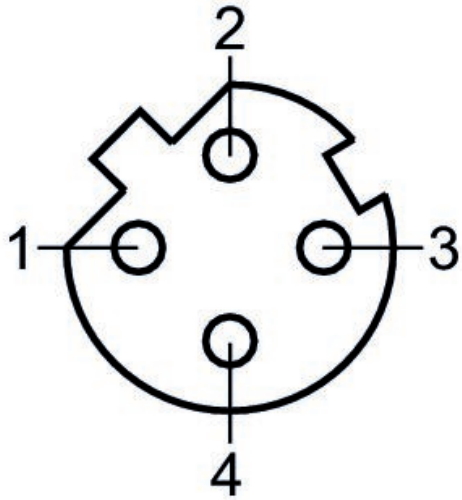

Plug pin assignment

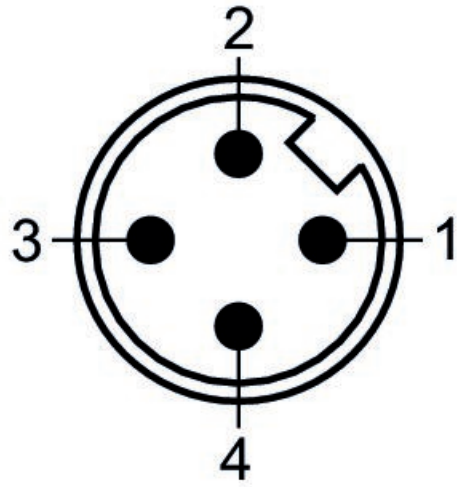

I/O modules, series AES

R412018269

General series information Series AES

- The AVENTICS Series AES fieldbus connection can be integrated into all AVENTICS fieldbus-compatible valve systems or can also be configured as a stand-alone solution. AES connects your AVENTICS valve system to all relevant fieldbus protocols and offers the integration of I/O-modules and enables optimized decentralized wiring of sensors. The integration of the Digital Twin enables users to be IIoT ready and use the AES to solve their interoperability challenges.



Technical data

Industry
Industrial

Version
I/O modules

Type
8DIDO8M8

Note
Combination module

E/A capable
connection with I/O

I/O module version
digital inputs/outputs

Number of I/O connections
8 inputs / 8 outputs

Power plug IN type
Internal

Signal connection E/A type
Socket

Signal connection E/A thread size
M8x1

Signal connection E/A number of poles
3-pin

Filter time
3 ms

Min. ambient temperature
-10 °C

Max. ambient temperature
60 °C

Operational voltage electronics
24 V DC

Electronics voltage tolerance
-25% / +25%

Max. current per channel
0.5 A

Total current for actuators
4 A

Protection class
IP65

Total current of sensors max.
1 A

Logic/actuator voltage
Galvanically isolated

Diagnosis
Short circuit
Undervoltage

Number of inputs 8	Generic immunity standard in accordance with norm EN 61000-6-2
Number of outputs 8	Weight 0.11 kg
Generic emission standard in accordance with norm EN 61000-6-4	

Material

Housing material Polyamide fiber-glass reinforced	Part No. R412018269
--	------------------------

Technical information

You will find assignment schemes for the product in the operating instructions, or contact the nearest AVENTICS sales office.

The total current of all outputs (including valves) must not exceed 4 A in the overall system.

Voltage and short-circuit monitoring per LED.

Delivery contents: incl. 2 spring clamp elements and seal

Function specification for fieldbus configuration.

Dimensions

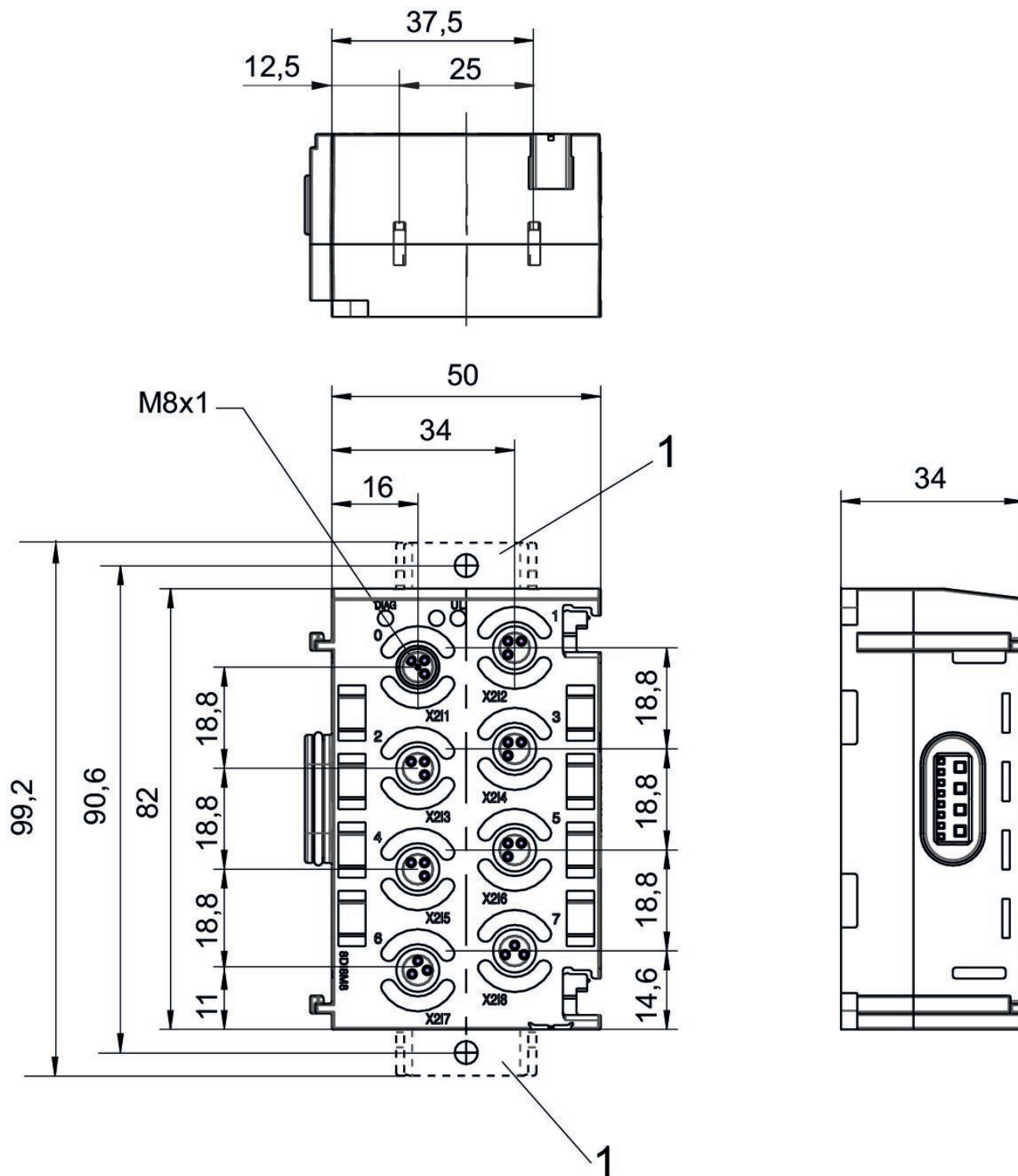

1) Retaining bracket (optional)
Pin assignment M8x1 (3-pin)

Pin assignments

PNP

3-pin

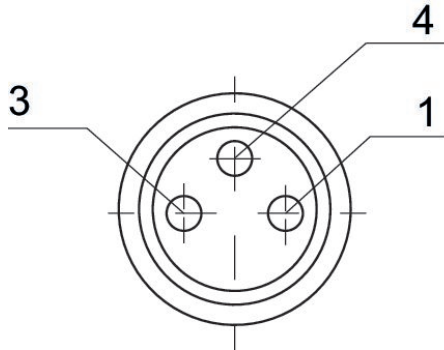

Pin	Input module	Output module
1	24 V DC	-
3	0 V DC	0 V DC
4	Input signal	Output signal

I/O modules, series AES

R412018233

General series information Series AES

- The AVENTICS Series AES fieldbus connection can be integrated into all AVENTICS fieldbus-compatible valve systems or can also be configured as a stand-alone solution. AES connects your AVENTICS valve system to all relevant fieldbus protocols and offers the integration of I/O-modules and enables optimized decentralized wiring of sensors. The integration of the Digital Twin enables users to be IIoT ready and use the AES to solve their interoperability challenges.



Technical data

Industry
Industrial

Version
I/O modules

Type
8DI8M8

E/A capable
connection with I/O

I/O module version
digital inputs

Number of I/O connections
8 inputs

Power plug IN type
Internal

Signal connection E/A type
Socket

Signal connection E/A thread size
M8x1

Signal connection E/A number of poles
3-pin

Filter time
3 ms

Min. ambient temperature
-10 °C

Max. ambient temperature
60 °C

Operational voltage electronics
24 V DC

Electronics voltage tolerance
-25% / +25%

Max. current per channel
0.5 A

Protection class
IP65

Total current of sensors max.
1 A

Diagnosis
Short circuit
Undervoltage

Number of inputs
8

Generic emission standard in accordance with
norm
EN 61000-6-4

Generic immunity standard in accordance with
norm
EN 61000-6-2

Weight
0.11 kg

Material

Housing material
Polyamide fiber-glass reinforced

Part No.
R412018233

Technical information

You will find assignment schemes for the product in the operating instructions, or contact the nearest AVENTICS sales office.

The total current of all outputs (including valves) must not exceed 4 A in the overall system.

Voltage and short-circuit monitoring per LED.

Delivery contents: incl. 2 spring clamp elements and seal

Dimensions

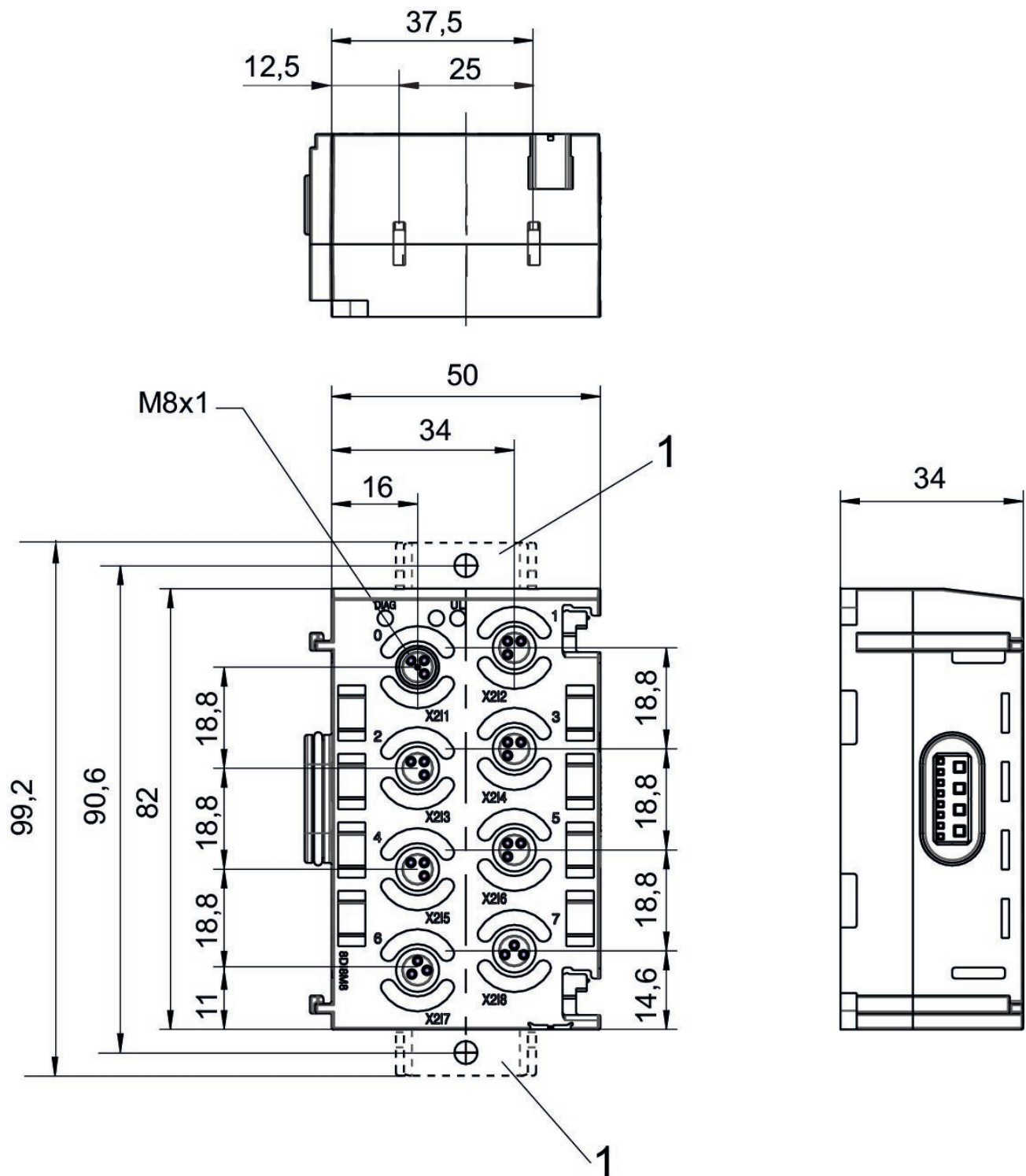

1) Retaining bracket (optional)
Pin assignment M8x1 (3-pin)

Pin assignments

PNP

3-pin

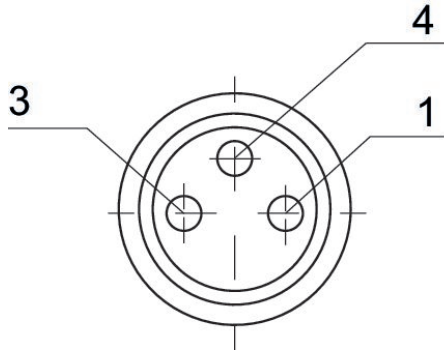

Pin	Input module	Output module
1	24 V DC	-
3	0 V DC	0 V DC
4	Input signal	Output signal

I/O modules, series AES

R412018248

General series information Series AES

- The AVENTICS Series AES fieldbus connection can be integrated into all AVENTICS fieldbus-compatible valve systems or can also be configured as a stand-alone solution. AES connects your AVENTICS valve system to all relevant fieldbus protocols and offers the integration of I/O-modules and enables optimized decentralized wiring of sensors. The integration of the Digital Twin enables users to be IIoT ready and use the AES to solve their interoperability challenges.



Technical data

Industry
Industrial

Version
I/O modules

Type
8DO8M8

E/A capable
connection with I/O

I/O module version
digital outputs

Number of I/O connections
8 outputs

Power plug IN type
Internal

Signal connection E/A type
Socket

Signal connection E/A thread size
M8x1

Signal connection E/A number of poles
3-pin

Filter time
3 ms

Min. ambient temperature
-10 °C

Max. ambient temperature
60 °C

Operational voltage electronics
24 V DC

Electronics voltage tolerance
-25% / +25%

Max. current per channel
0.5 A

Total current for actuators
4 A

Protection class
IP65

Total current of sensors max.
1 A

Logic/actuator voltage
Galvanically isolated

Diagnosis
Short circuit
Undervoltage

Number of outputs
8

Generic emission standard in accordance with
norm
EN 61000-6-4

Generic immunity standard in accordance with
norm
EN 61000-6-2
Weight
0.11 kg

Material

Housing material
Polyamide fiber-glass reinforced

Part No.
R412018248

Technical information

You will find assignment schemes for the product in the operating instructions, or contact the nearest AVENTICS sales office.

The total current of all outputs (including valves) must not exceed 4 A in the overall system.

Voltage and short-circuit monitoring per LED.

Delivery contents: incl. 2 spring clamp elements and seal

Dimensions

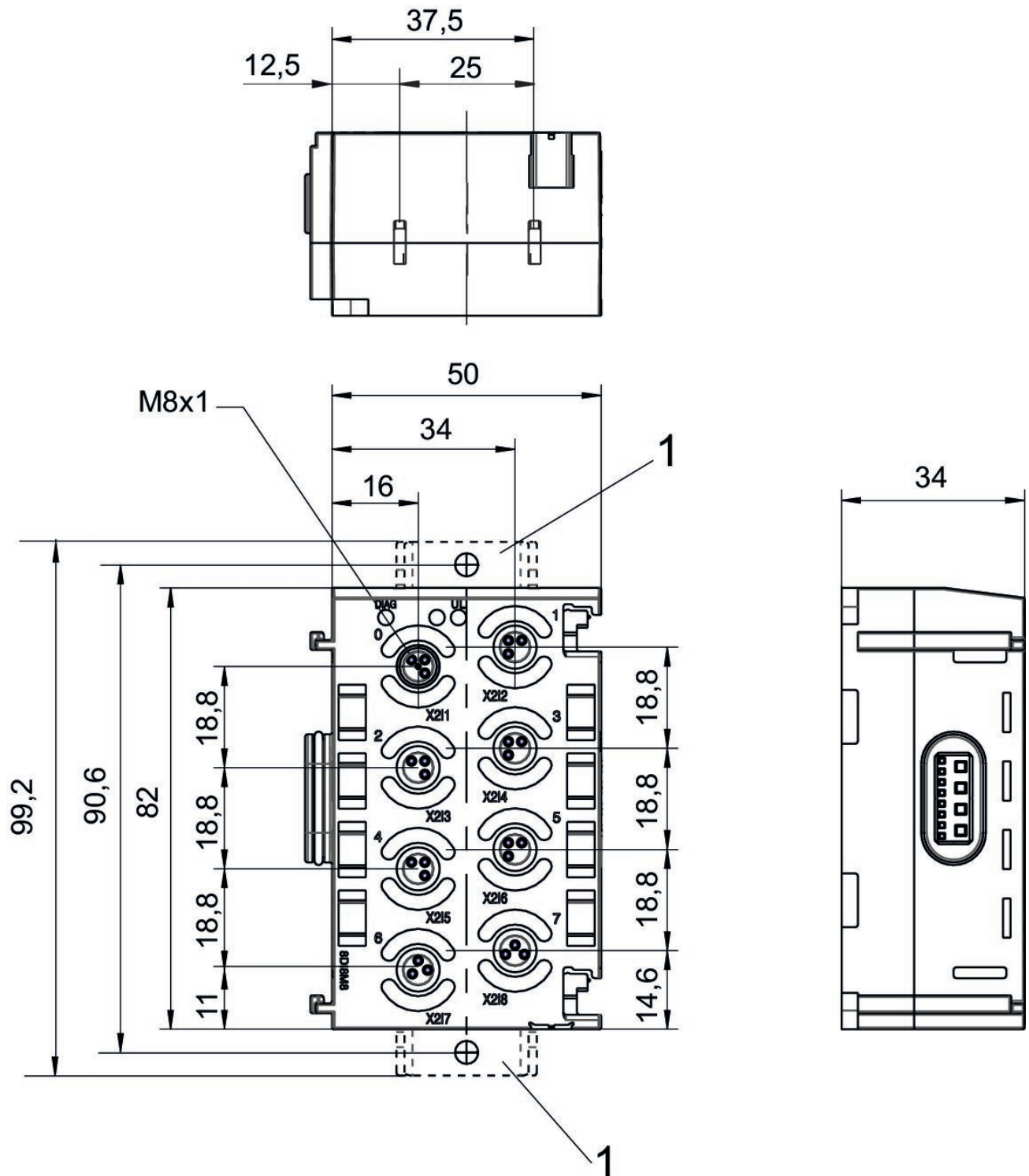

1) Retaining bracket (optional)
Pin assignment M8x1 (3-pin)

Pin assignments

PNP

3-pin

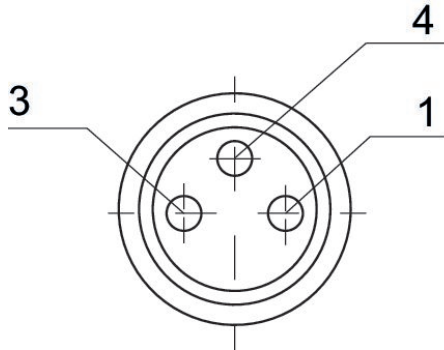

Pin	Input module	Output module
1	24 V DC	-
3	0 V DC	0 V DC
4	Input signal	Output signal

I/O modules, Series AES

R412018234

General series information Series AES

- The AVENTICS Series AES fieldbus connection can be integrated into all AVENTICS fieldbus-compatible valve systems or can also be configured as a stand-alone solution. AES connects your AVENTICS valve system to all relevant fieldbus protocols and offers the integration of I/O-modules and enables optimized decentralized wiring of sensors. The integration of the Digital Twin enables users to be IIoT ready and use the AES to solve their interoperability challenges.



Technical data

Industry
Industrial

Version
I/O modules

Type
16DI8M8

E/A capable
connection with I/O

I/O module version
digital inputs

Number of I/O connections
16 inputs

Power plug IN type
Internal

Signal connection E/A type
Socket

Signal connection E/A thread size
M8x1

Signal connection E/A number of poles
4-pin

Filter time
3 ms

Min. ambient temperature
-10 °C

Max. ambient temperature
60 °C

Operational voltage electronics
24 V DC

Electronics voltage tolerance
-25% / +25%

Max. current per channel
0.5 A

Protection class
IP65

Total current of sensors max.
1 A

Diagnosis
Short circuit
Undervoltage

Generic emission standard in accordance with
norm
EN 61000-6-4

Generic immunity standard in accordance with
norm
EN 61000-6-2

Weight
0.11 kg

Material

Housing material
Polyamide fiber-glass reinforced

Part No.
R412018234

Technical information

You will find assignment schemes for the product in the operating instructions, or contact the nearest AVENTICS sales office.

The total current of all outputs (including valves) must not exceed 4 A in the overall system.

Voltage and short-circuit monitoring per LED.

Delivery contents: incl. 2 spring clamp elements and seal

Dimensions

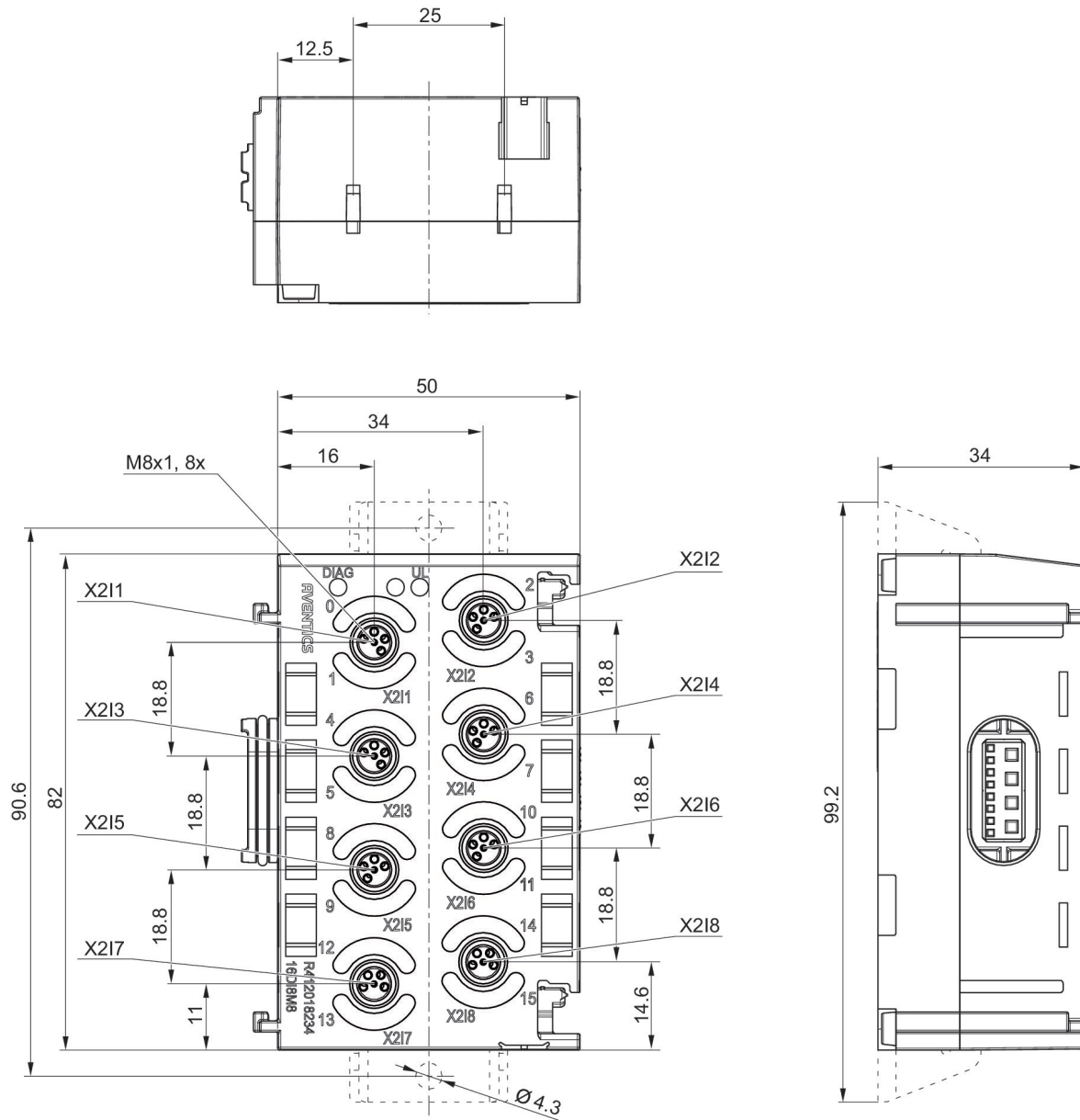

1) Retaining bracket (optional)
Pin assignment M8x1 (4-pin)

Pin assignments

X211-X218

4-pin

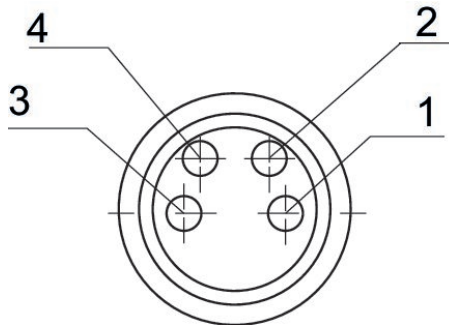

PNP

Pin	Input module
1	24 V DC sensor voltage
2	Input signal (most significant bit)
3	0 V DC sensor voltage
4	Input signal (lower order bit)

I/O modules, series AES

R412018235

General series information Series AES

- The AVENTICS Series AES fieldbus connection can be integrated into all AVENTICS fieldbus-compatible valve systems or can also be configured as a stand-alone solution. AES connects your AVENTICS valve system to all relevant fieldbus protocols and offers the integration of I/O-modules and enables optimized decentralized wiring of sensors. The integration of the Digital Twin enables users to be IIoT ready and use the AES to solve their interoperability challenges.



Technical data

Industry
Industrial

Version
I/O modules

Type
8DI4M12

E/A capable
connection with I/O

I/O module version
digital inputs

Number of I/O connections
8 inputs

Power plug IN type
Internal

Signal connection E/A type
Socket

Signal connection E/A thread size
M12x1

Signal connection E/A number of poles
5-pin

Filter time
3 ms

Min. ambient temperature
-10 °C

Max. ambient temperature
60 °C

Operational voltage electronics
24 V DC

Electronics voltage tolerance
-25% / +25%

Max. current per channel
0.5 A

Power supply for actuators
8x0,5 A

Protection class
IP65

Total current of sensors max.
1 A

Diagnosis
Short circuit

Generic emission standard in accordance with
norm
EN 61000-6-4

Generic immunity standard in accordance with
norm
EN 61000-6-2

Weight
0.11 kg

Material

Housing material
Polyamide fiber-glass reinforced

Part No.
R412018235

Technical information

You will find assignment schemes for the product in the operating instructions, or contact the nearest AVENTICS sales office.

The total current of all outputs (including valves) must not exceed 4 A in the overall system.

Voltage and short-circuit monitoring per LED.

Delivery contents: incl. 2 spring clamp elements and seal

Dimensions

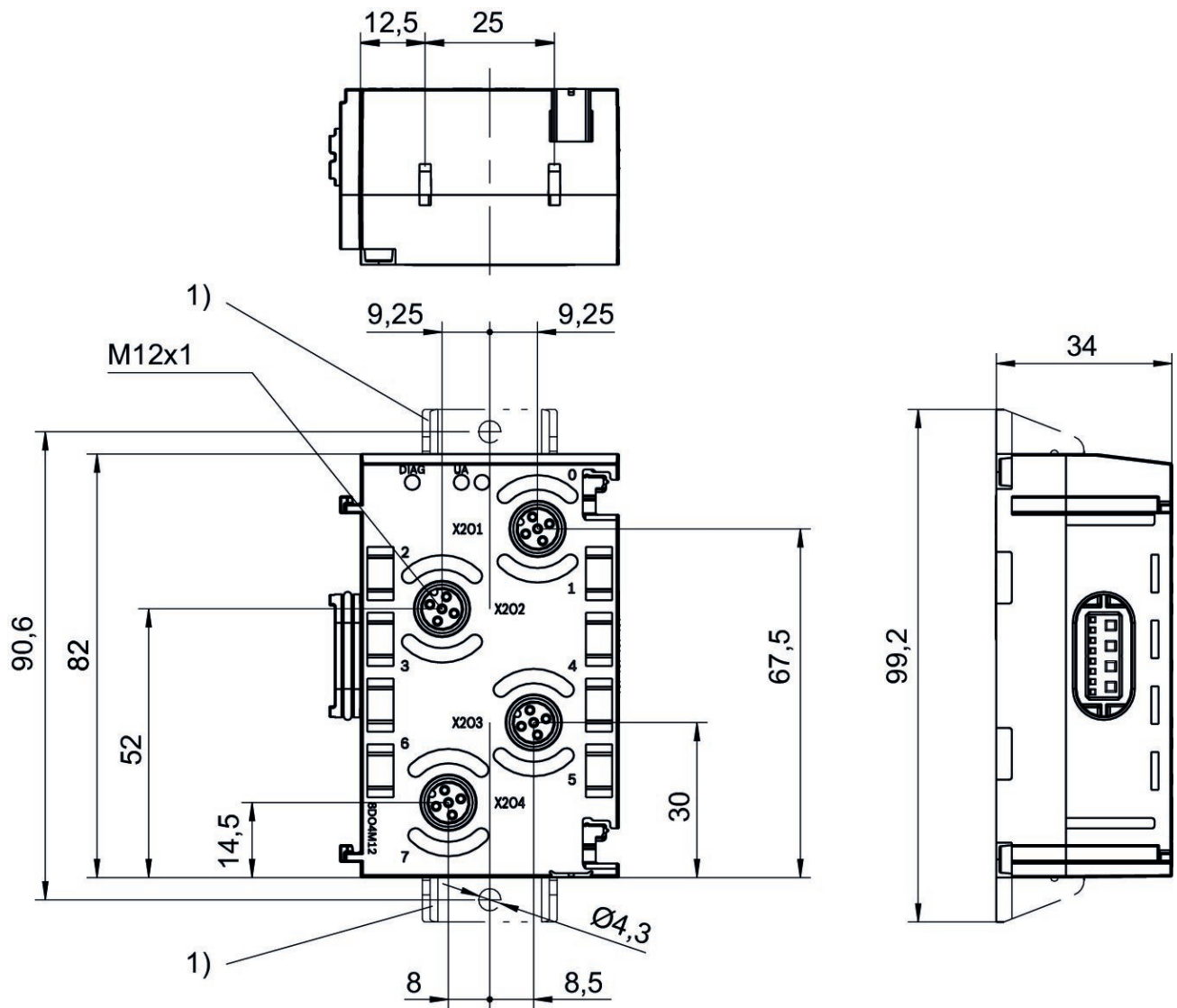

1) Retaining bracket (optional)

Pin assignments

PNP

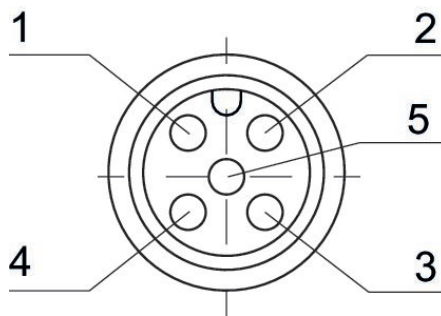

Pin	Input module	Output module
1	24 V DC	-
2	Input signal [X+1]	Output signal [X+1]
3	0 V DC	0 V DC
4	Input signal [X]	Output signal [X]
5	-	-

X = bit value

I/O modules, series AES

R412018250

General series information Series AES

- The AVENTICS Series AES fieldbus connection can be integrated into all AVENTICS fieldbus-compatible valve systems or can also be configured as a stand-alone solution. AES connects your AVENTICS valve system to all relevant fieldbus protocols and offers the integration of I/O-modules and enables optimized decentralized wiring of sensors. The integration of the Digital Twin enables users to be IIoT ready and use the AES to solve their interoperability challenges.



Technical data

Industry
Industrial

Version
I/O modules

Type
8DO4M12

E/A capable
connection with I/O

I/O module version
digital outputs

Number of I/O connections
8 outputs

Power plug IN type
Internal

Signal connection E/A type
Socket

Signal connection E/A thread size
M12x1

Signal connection E/A number of poles
5-pin

Filter time
3 ms

Min. ambient temperature
-10 °C

Max. ambient temperature
60 °C

Operational voltage electronics
24 V DC

Electronics voltage tolerance
-25% / +25%

Max. current per channel
0.5 A

Power supply for actuators
8x0,5 A

Total current for actuators
4 A

Protection class
IP65

Total current of sensors max.
1 A

Logic/actuator voltage
Galvanically isolated

Diagnosis
Short circuit

Generic emission standard in accordance with
norm
EN 61000-6-4

Generic immunity standard in accordance with
norm
EN 61000-6-2
Weight
0.11 kg

Material

Housing material
Polyamide fiber-glass reinforced

Part No.
R412018250

Technical information

You will find assignment schemes for the product in the operating instructions, or contact the nearest AVENTICS sales office.

The total current of all outputs (including valves) must not exceed 4 A in the overall system.

Voltage and short-circuit monitoring per LED.

Delivery contents: incl. 2 spring clamp elements and seal

Dimensions

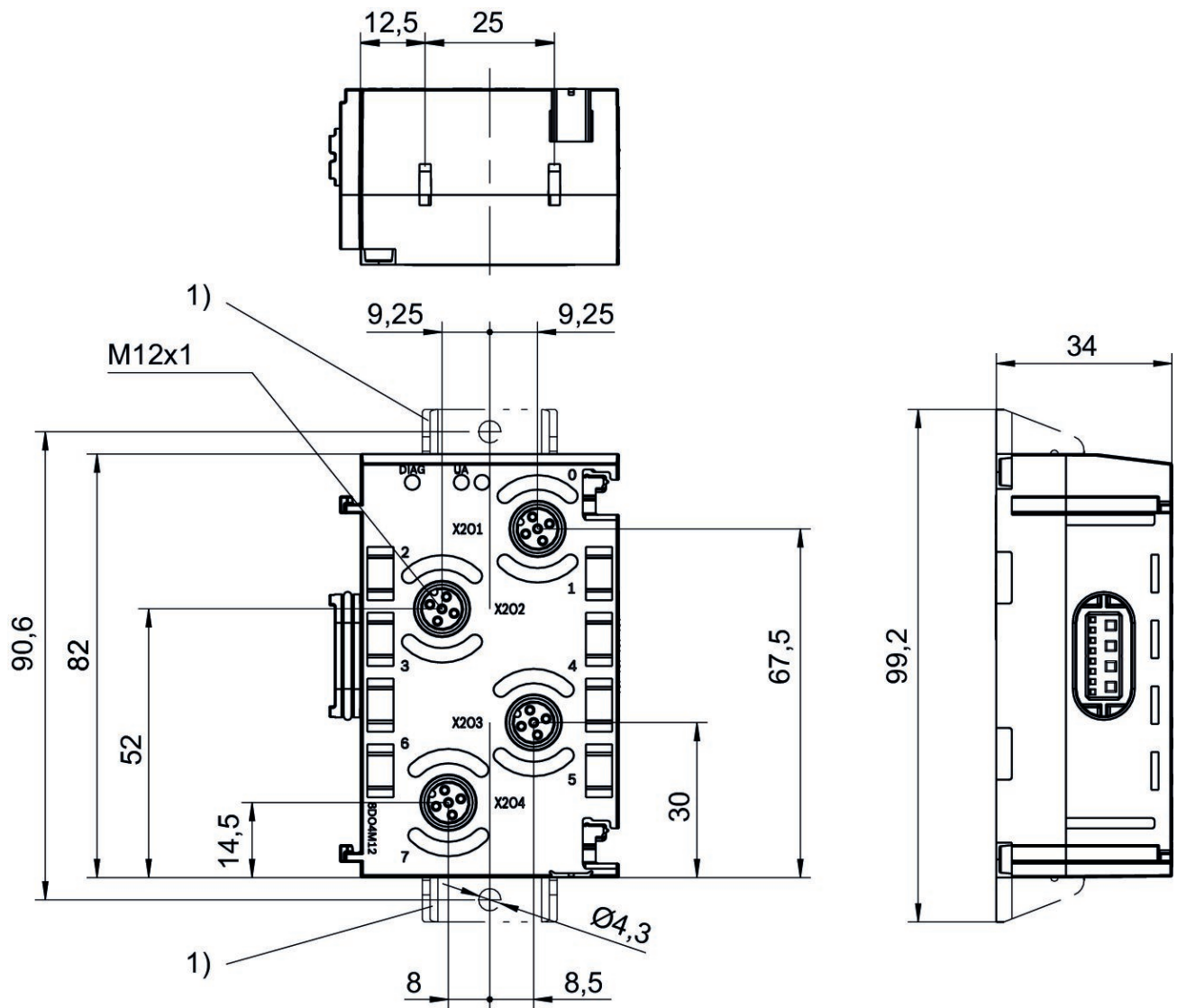

1) Retaining bracket (optional)

Pin assignments

PNP

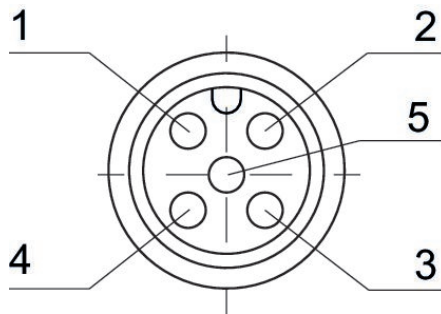

Pin	Input module	Output module
1	24 V DC	-
2	Input signal [X+1]	Output signal [X+1]
3	0 V DC	0 V DC
4	Input signal [X]	Output signal [X]
5	-	-

X = bit value

I/O modules, series AES

R412018270

General series information Series AES

- The AVENTICS Series AES fieldbus connection can be integrated into all AVENTICS fieldbus-compatible valve systems or can also be configured as a stand-alone solution. AES connects your AVENTICS valve system to all relevant fieldbus protocols and offers the integration of I/O-modules and enables optimized decentralized wiring of sensors. The integration of the Digital Twin enables users to be IIoT ready and use the AES to solve their interoperability challenges.



Technical data

Industry
Industrial

Version
I/O modules

Type
8DIDO4M12

Note
Combination module

E/A capable
connection with I/O

I/O module version
digital inputs/outputs

Number of I/O connections
8 inputs / 8 outputs

Power plug IN type
Internal

Signal connection E/A type
Socket

Signal connection E/A thread size
M12x1

Signal connection E/A number of poles
5-pin

Min. ambient temperature
-10 °C

Max. ambient temperature
60 °C

Operational voltage electronics
24 V DC

Electronics voltage tolerance
-25% / +25%

Max. current per channel
0.5 A

Power supply for actuators
8x0,5 A

Total current for actuators
4 A

Protection class
IP65

Total current of sensors max.
1 A

Logic/actuator voltage
Galvanically isolated

Diagnosis
Short circuit

Generic emission standard in accordance with
norm
EN 61000-6-4

Generic immunity standard in accordance with
norm
EN 61000-6-2
Weight
0.11 kg

Material

Housing material
Polyamide fiber-glass reinforced

Part No.
R412018270

Technical information

You will find assignment schemes for the product in the operating instructions, or contact the nearest AVENTICS sales office.

The total current of all outputs (including valves) must not exceed 4 A in the overall system.

Voltage and short-circuit monitoring per LED.

Delivery contents: incl. 2 spring clamp elements and seal

Function specification for fieldbus configuration.

Dimensions

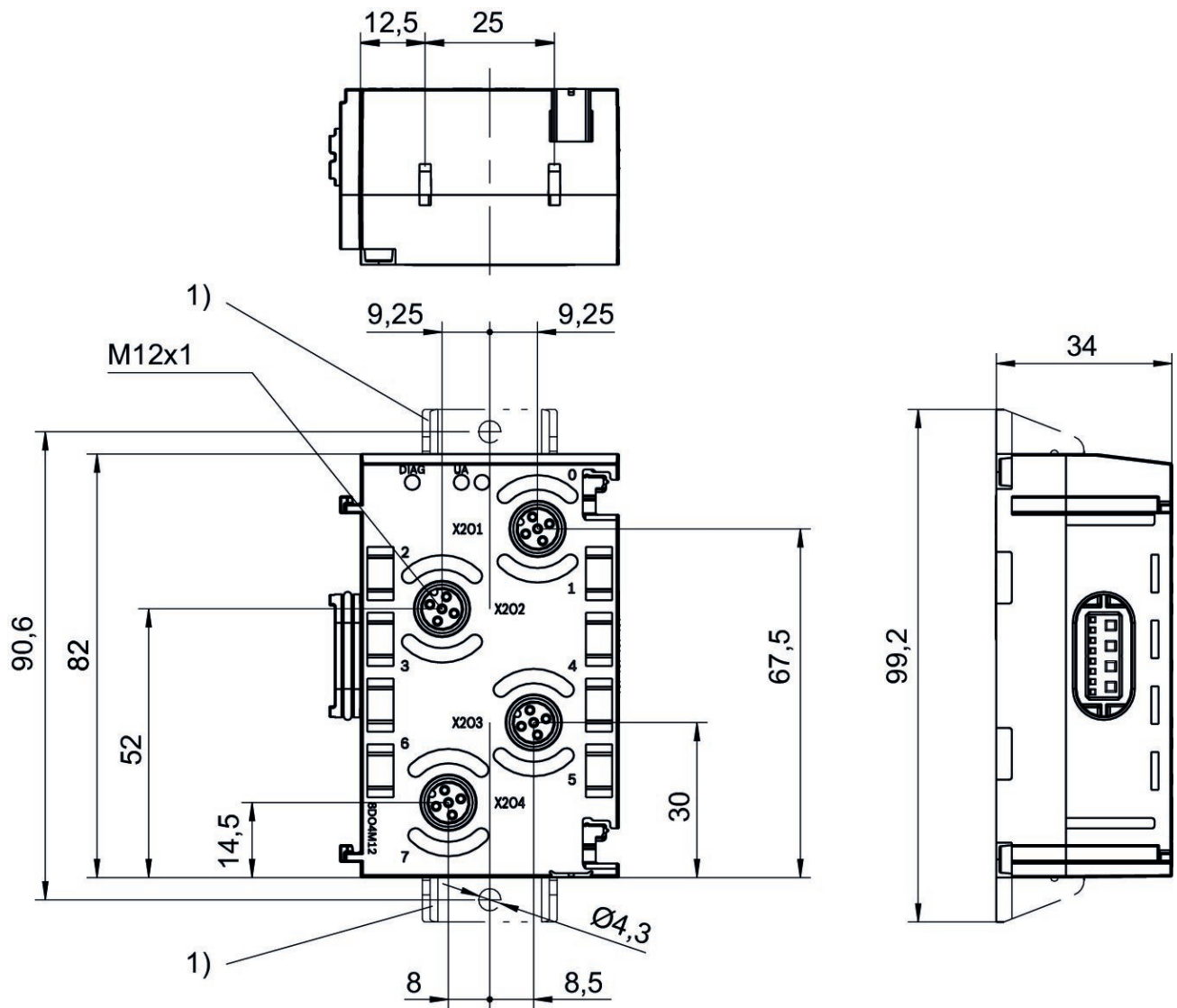

1) Retaining bracket (optional)

Pin assignments PNP

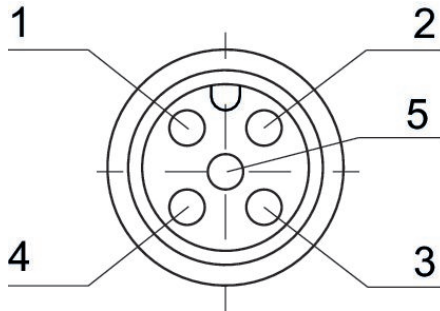

Pin	Input module	Output module
1	24 V DC	-
2	Input signal [X+1]	Output signal [X+1]
3	0 V DC	0 V DC
4	Input signal [X]	Output signal [X]
5	-	-

X = bit value

I/O modules, series AES

R412018243

General series information Series AES

- The AVENTICS Series AES fieldbus connection can be integrated into all AVENTICS fieldbus-compatible valve systems or can also be configured as a stand-alone solution. AES connects your AVENTICS valve system to all relevant fieldbus protocols and offers the integration of I/O-modules and enables optimized decentralized wiring of sensors. The integration of the Digital Twin enables users to be IIoT ready and use the AES to solve their interoperability challenges.



Technical data

Industry
Industrial

Version
I/O modules

Type
16DI4M12

E/A capable
connection with I/O

I/O module version
digital inputs

Number of I/O connections
16 inputs

Power plug IN type
Internal

Signal connection E/A type
Socket

Signal connection E/A thread size
M12x1

Signal connection E/A number of poles
8-pin

Filter time
3 ms

Min. ambient temperature
-10 °C

Max. ambient temperature
60 °C

Operational voltage electronics
24 V DC

Electronics voltage tolerance
-10% / +10%

Max. current per channel
0.5 A

Protection class
IP65

Total current of sensors max.
1 A

Diagnosis
Short circuit

Generic emission standard in accordance with
norm
EN 61000-6-4

Generic immunity standard in accordance with
norm
EN 61000-6-2

Weight
0.11 kg

Material

Housing material
Polyamide fiber-glass reinforced

Part No.
R412018243

Technical information

You will find assignment schemes for the product in the operating instructions, or contact the nearest AVENTICS sales office.

The total current of all outputs (including valves) must not exceed 4 A in the overall system.

Voltage and short-circuit monitoring per LED.

Delivery contents: incl. 2 spring clamp elements and seal

Dimensions

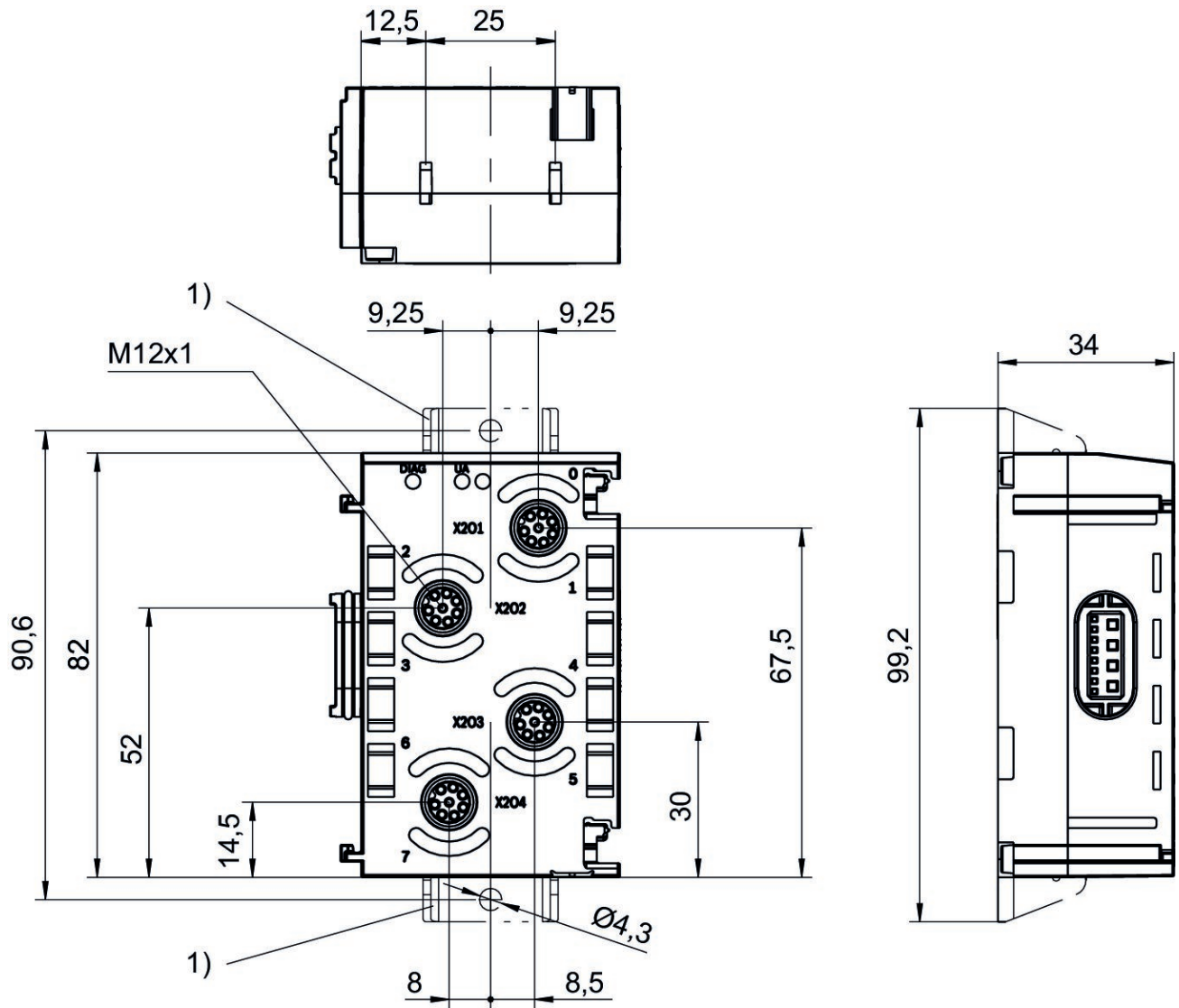

1) Retaining bracket (optional)

Pin assignments

PNP

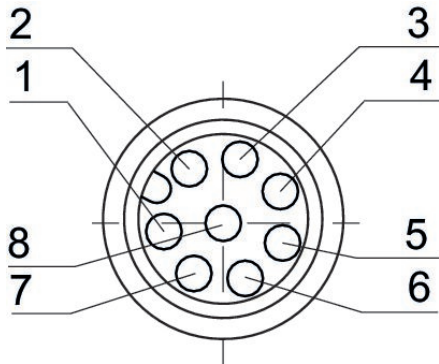

Pin	Input module	Output module
1	Input signal [X]	Output signal 24 V DC [X]
2	Input signal [X+1]	Output signal 24 V DC [X+1]
3	Input signal [X+2]	Output signal 24 V DC [X+2]
4	Input signal [X+3]	Output signal 24 V DC [X+3]
5	24 V DC	-
6	-	-
7	0 V DC	0 V DC
8	-	-
X = bit value		

X = bit value

I/O modules, series AES

R412018263

General series information Series AES

- The AVENTICS Series AES fieldbus connection can be integrated into all AVENTICS fieldbus-compatible valve systems or can also be configured as a stand-alone solution. AES connects your AVENTICS valve system to all relevant fieldbus protocols and offers the integration of I/O-modules and enables optimized decentralized wiring of sensors. The integration of the Digital Twin enables users to be IIoT ready and use the AES to solve their interoperability challenges.



Technical data

Industry
Industrial

Version
I/O modules

Type
16DO4M12

E/A capable
connection with I/O

I/O module version
digital outputs

Number of I/O connections
16 outputs

Power plug IN type
Internal

Signal connection E/A type
Socket

Signal connection E/A thread size
M12x1

Signal connection E/A number of poles
8-pin

Filter time
3 ms

Min. ambient temperature
-10 °C

Max. ambient temperature
60 °C

Operational voltage electronics
24 V DC

Electronics voltage tolerance
-10% / +10%

Max. current per channel
0.5 A

Total current for actuators
4 A

Protection class
IP65

Total current of sensors max.
1 A

Logic/actuator voltage
Galvanically isolated

Diagnosis
Short circuit

Generic emission standard in accordance with
norm
EN 61000-6-4

Generic immunity standard in accordance with
norm
EN 61000-6-2
Weight
0.11 kg

Material

Housing material
Polyamide fiber-glass reinforced

Part No.
R412018263

Technical information

You will find assignment schemes for the product in the operating instructions, or contact the nearest AVENTICS sales office.

The total current of all outputs (including valves) must not exceed 4 A in the overall system.

Voltage and short-circuit monitoring per LED.

Delivery contents: incl. 2 spring clamp elements and seal

Dimensions

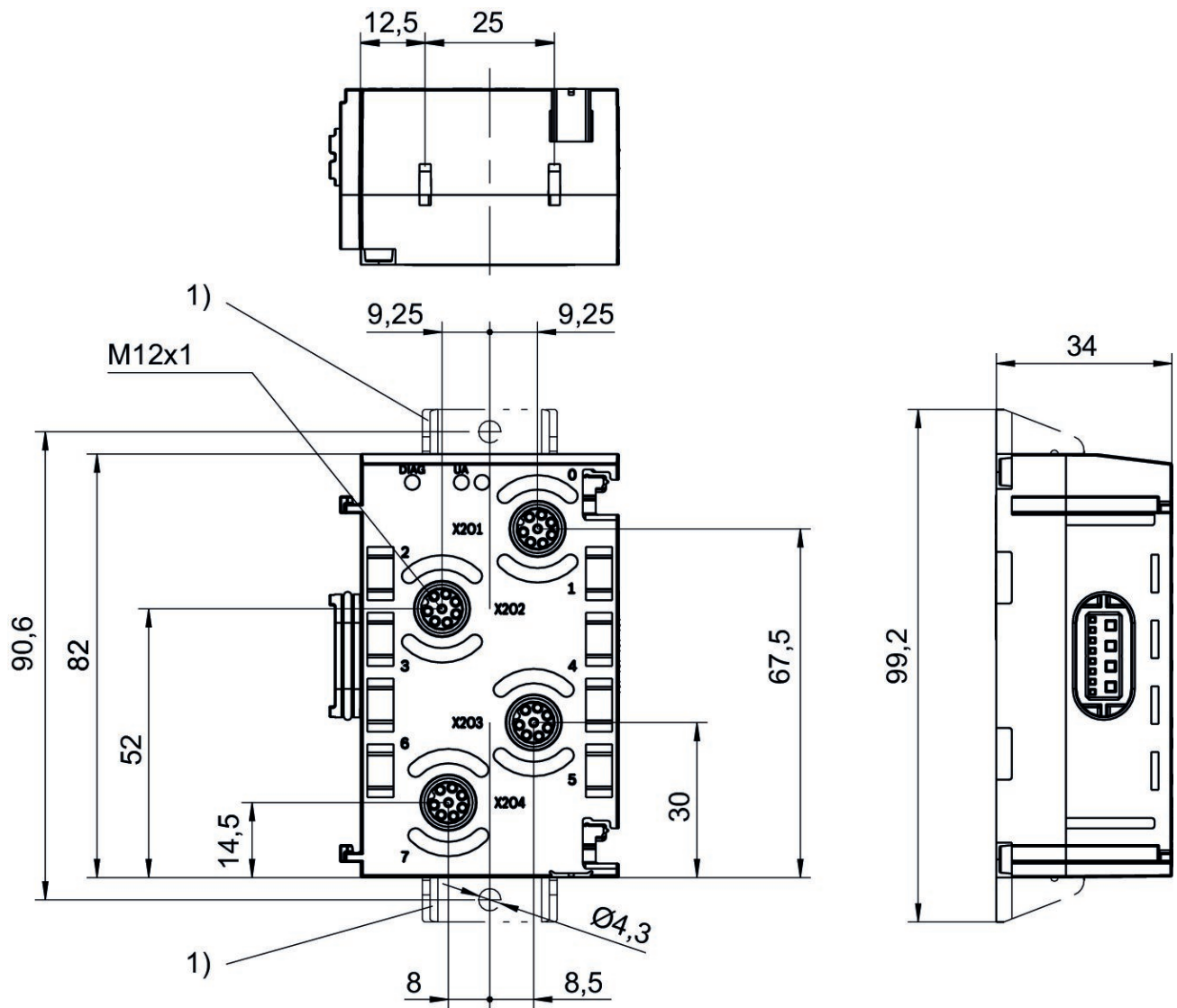

1) Retaining bracket (optional)

Pin assignments

PNP

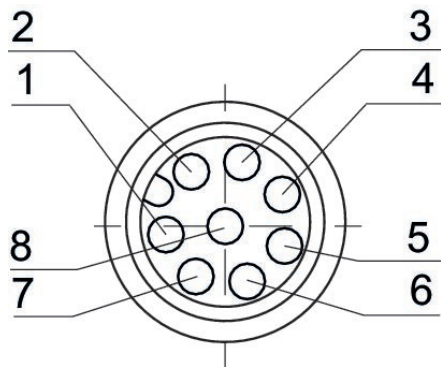

Pin	Input module	Output module
1	Input signal [X]	Output signal 24 V DC [X]
2	Input signal [X+1]	Output signal 24 V DC [X+1]
3	Input signal [X+2]	Output signal 24 V DC [X+2]
4	Input signal [X+3]	Output signal 24 V DC [X+3]
5	24 V DC	-
6	-	-
7	0 V DC	0 V DC
8	-	-
X = bit value		

X = bit value

I/O modules, series AES

R412018254

General series information Series AES

- The AVENTICS Series AES fieldbus connection can be integrated into all AVENTICS fieldbus-compatible valve systems or can also be configured as a stand-alone solution. AES connects your AVENTICS valve system to all relevant fieldbus protocols and offers the integration of I/O-modules and enables optimized decentralized wiring of sensors. The integration of the Digital Twin enables users to be IIoT ready and use the AES to solve their interoperability challenges.



Technical data

Industry
Industrial

Version
I/O modules

Type
24DO1DSUB25

E/A capable
connection with I/O

I/O module version
digital outputs

Number of I/O connections
24 outputs

Power plug IN type
Internal

Signal connection E/A type
Socket

Signal connection E/A thread size
D-Sub

Signal connection E/A number of poles
25-pin

Min. ambient temperature
-10 °C

Max. ambient temperature
60 °C

Operational voltage electronics
24 V DC

Max. current per channel
0.5 A

Total current for actuators
4 A

Protection class
IP65

Logic/actuator voltage
Galvanically isolated

Diagnosis
Short circuit
Undervoltage

Generic emission standard in accordance with
norm
EN 61000-6-4

Generic immunity standard in accordance with
norm
EN 61000-6-2

Weight
0.115 kg

Material

Housing material
Polyamide fiber-glass reinforced

Part No.
R412018254

Technical information

You will find assignment schemes for the product in the operating instructions, or contact the nearest AVENTICS sales office.

Voltage and short-circuit monitoring per LED.

Delivery contents: incl. 2 spring clamp elements and seal

Dimensions

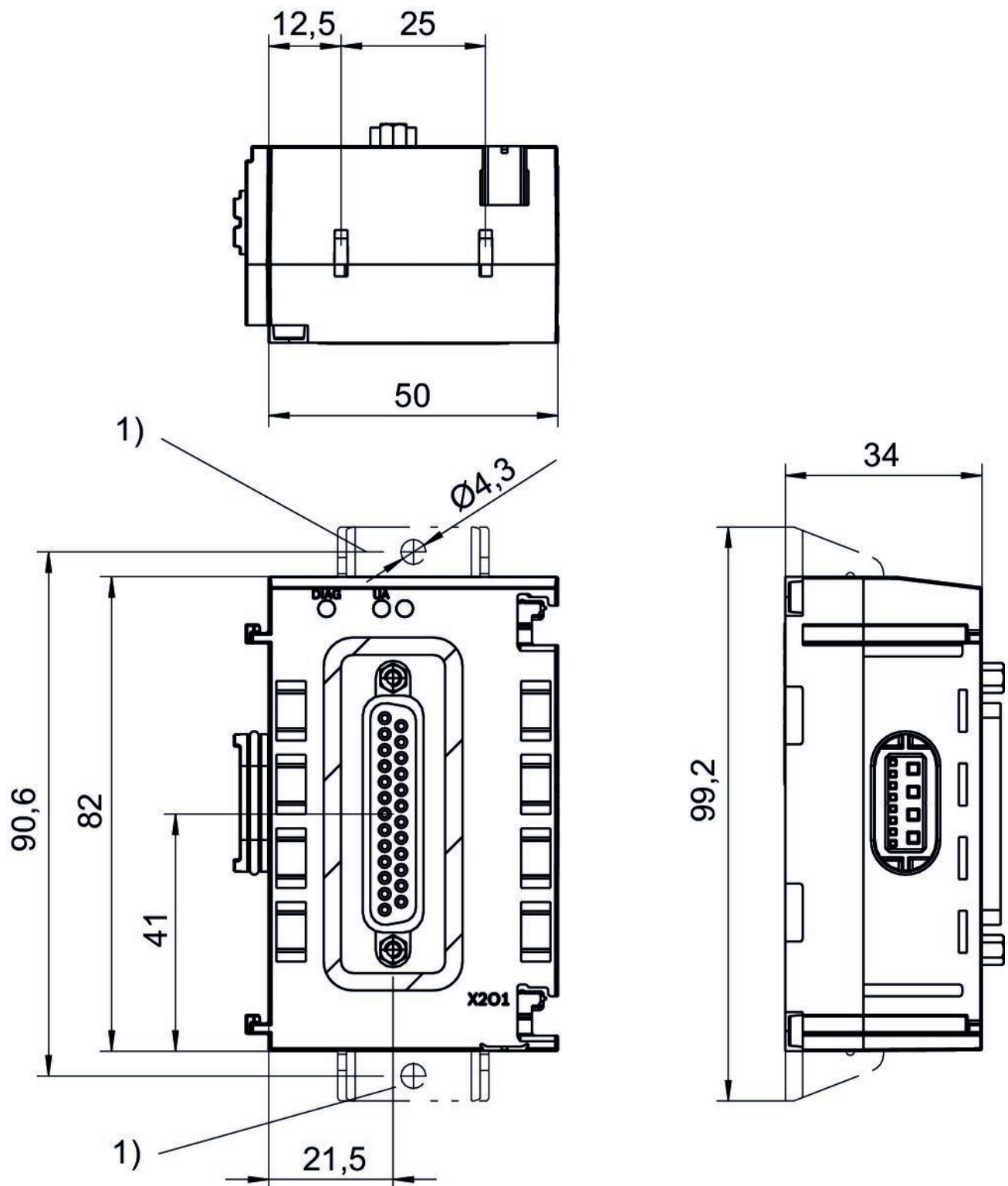

1) Retaining bracket (optional)

PIN assignment and cable colors cable identification as per DIN 47100

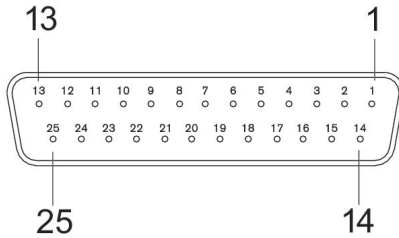

Socket

Pin	Output module
1	[X]
2	[X+0.1]
3	[X+0.2]
4	[X+0.3]
5	[X+0.4]
6	[X+0.5]
7	[X+0.6]
8	[X+0.7]
9	[X+1]
10	[X+1.1]
11	[X+1.2]
12	[X+1.3]
13	[X+1.4]
14	[X+1.5]
15	[X+1.6]
16	[X+1.7]
17	[X+2.0]
18	[X+2.1]
19	[X+2.2]
20	[X+2.3]
21	[X+2.4]
22	[X+2.5]
23	[X+2.6]
24	[X+2.7]
25	0 V DC

X = bit value

I/O modules, series AES

R412018242

General series information Series AES

- The AVENTICS Series AES fieldbus connection can be integrated into all AVENTICS fieldbus-compatible valve systems or can also be configured as a stand-alone solution. AES connects your AVENTICS valve system to all relevant fieldbus protocols and offers the integration of I/O-modules and enables optimized decentralized wiring of sensors. The integration of the Digital Twin enables users to be IIoT ready and use the AES to solve their interoperability challenges.



Technical data

Industry
Industrial

Version
I/O modules

Type
16DI48SC

E/A capable
connection with I/O

I/O module version
digital inputs

Number of I/O connections
16 inputs

Power plug IN type
Internal

Signal connection E/A type
Spring clamp connections

Min. ambient temperature
-10 °C

Max. ambient temperature
60 °C

Operational voltage electronics
24 V DC

Electronics voltage tolerance
-25% / +25%

Max. current per channel
0.5 A

Protection class
IP20

Total current of sensors max.
1 A

Diagnosis
Short circuit

Generic emission standard in accordance with
norm
EN 61000-6-4

Generic immunity standard in accordance with
norm
EN 61000-6-2

Weight
0.115 kg

Material

Housing material
Polyamide fiber-glass reinforced

Part No.
R412018242

Technical information

You will find assignment schemes for the product in the operating instructions, or contact the nearest AVENTICS sales office.

Voltage and short-circuit monitoring per LED.

The clamp area for stranded wires is between 0.2 and 1.5 mm².

Delivery contents: incl. 2 spring clamp elements and seal

Dimensions

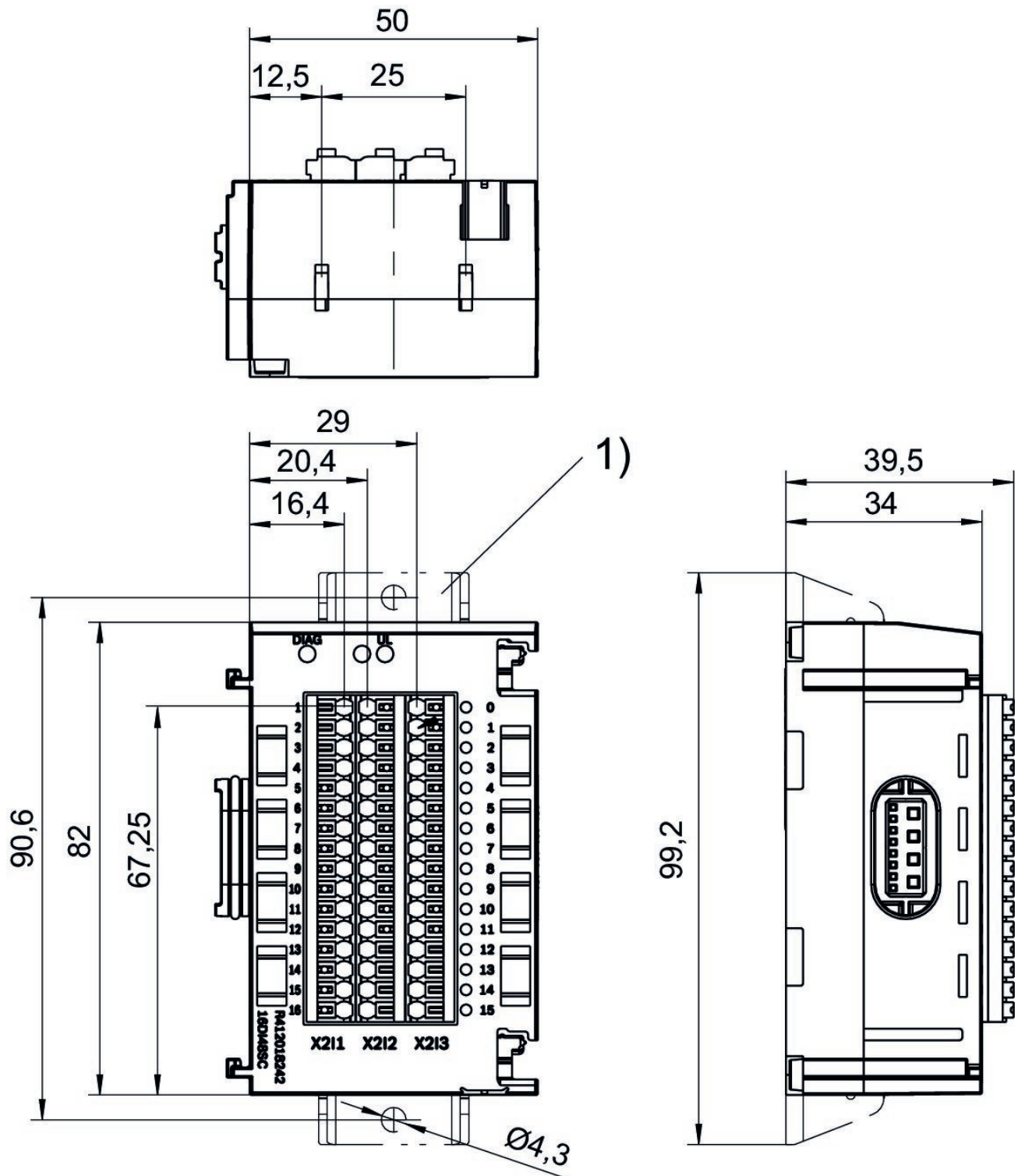

1) Retaining bracket (optional)

Port	Contact	Function Input signal
X2I1	1	24 V DC bit 0.0
	2	24 V DC bit 0.1
	3	24 V DC bit 0.2
	4	24 V DC bit 0.3
	5	24 V DC bit 0.4
	6	24 V DC bit 0.5
	7	24 V DC bit 0.6
	8	24 V DC bit 0.7
	9	24 V DC bit 1.0
	10	24 V DC bit 1.1
	11	24 V DC bit 1.2
	12	24 V DC bit 1.3
	13	24 V DC bit 1.4
	14	24 V DC bit 1.5
	15	24 V DC bit 1.6
	16	24 V DC bit 1.7
X2I2	1-16	24 V DC
X2I3	1-16	0 V DC

Power module Series AES

R412018267

General series information Series AES

- The AVENTICS Series AES fieldbus connection can be integrated into all AVENTICS fieldbus-compatible valve systems or can also be configured as a stand-alone solution. AES connects your AVENTICS valve system to all relevant fieldbus protocols and offers the integration of I/O-modules and enables optimized decentralized wiring of sensors. The integration of the Digital Twin enables users to be IIoT ready and use the AES to solve their interoperability challenges.



Technical data

Industry
Industrial

Version
Power module

E/A capable
connection with I/O

Power plug IN type
Plug

Power plug IN size
M12x1

Power plug IN number of pole
4-pin

Power plug OUT type
Socket

Power plug OUT size
M12x1

Power plug OUT number of pole
4-pin

Power supply direction UA
left

Min. ambient temperature
-10 °C

Max. ambient temperature
60 °C

Operational voltage electronics
24 V DC

Electronics voltage tolerance
-20% / +20%

Operating voltage, actuators
24 V DC

Actuator voltage tolerance
-10% / +10%

Total current for actuators
4 A

Protection class
IP65

Total current of sensors max.
4 A

Generic emission standard in accordance with
norm
EN 61000-6-4

Generic immunity standard in accordance with
norm
EN 61000-6-2

Weight
0.15 kg

Material

Housing material
Polyamide fiber-glass reinforced

Part No.
R412018267

Technical information

You will find assignment schemes for the product in the operating instructions, or contact the nearest AVENTICS sales office.

UL: Logic voltage (power supply for electronic components and sensors)

UA: Actuator voltage (power supply for valves and outputs)

The supply voltage is galvanically isolated from the right-hand module.

Dimensions

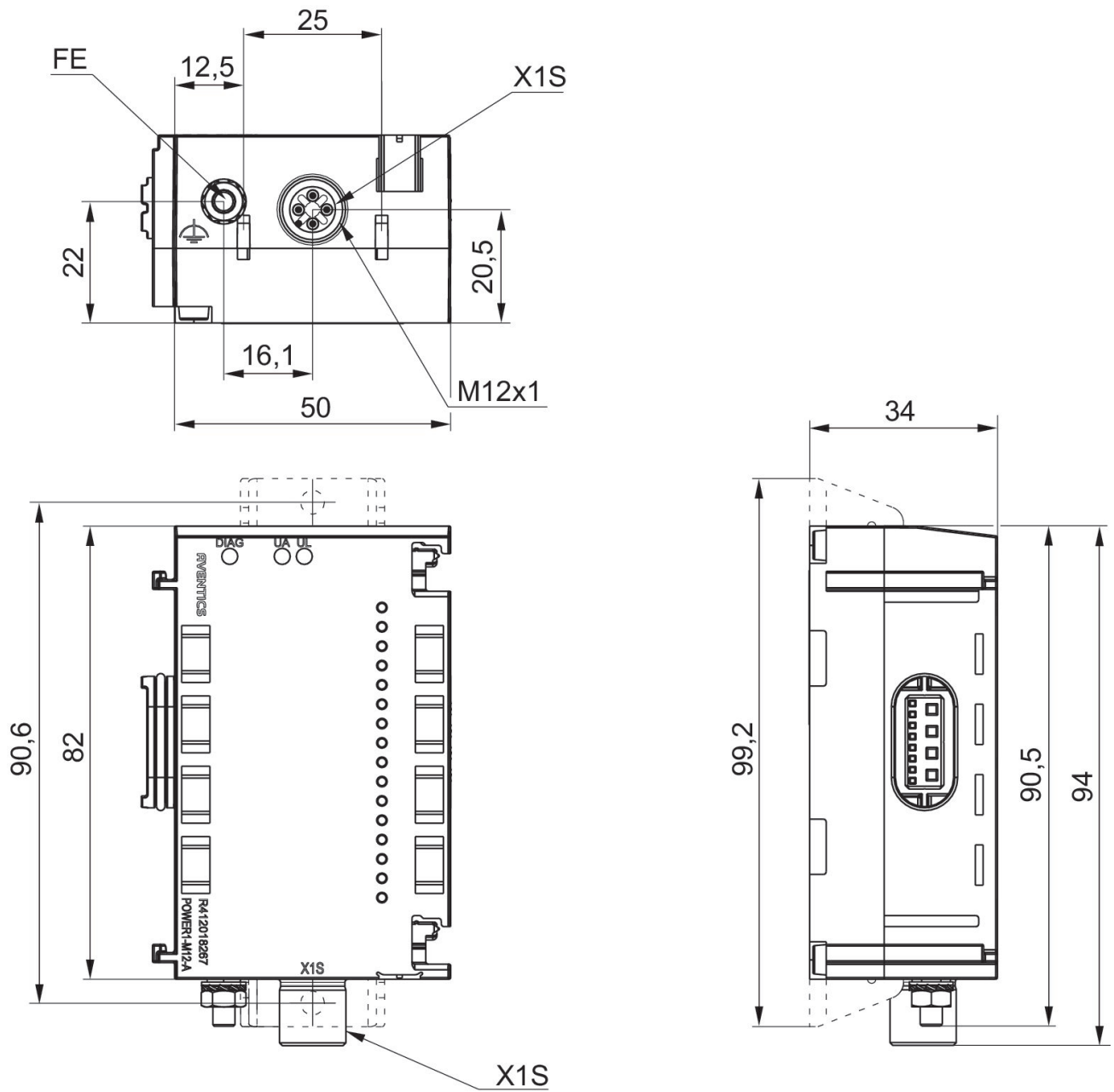

Port 1, X1S

Pin assignments PNP

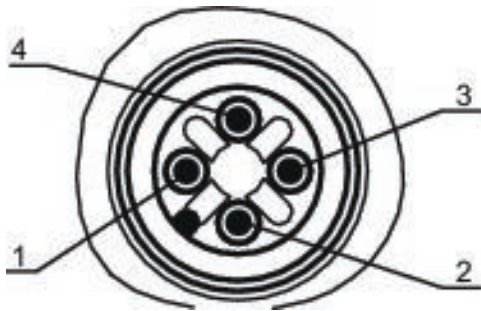

Pin	R412018267 (UA)	R412018267 (UL)
1	-	24 V DC power supply (UL) input
2	24 V DC power supply (UA) input	-
3	-	0 V DC (UL)
4	0 V DC (UA)	-

Power module Series AES

R412018268

General series information Series AES

- The AVENTICS Series AES fieldbus connection can be integrated into all AVENTICS fieldbus-compatible valve systems or can also be configured as a stand-alone solution. AES connects your AVENTICS valve system to all relevant fieldbus protocols and offers the integration of I/O-modules and enables optimized decentralized wiring of sensors. The integration of the Digital Twin enables users to be IIoT ready and use the AES to solve their interoperability challenges.



Technical data

Industry
Industrial

Version
Power module

E/A capable
connection with I/O

Power plug IN type
Plug

Power plug IN size
M12x1

Power plug IN number of pole
4-pin

Power plug OUT type
Socket

Power plug OUT size
M12x1

Power plug OUT number of pole
4-pin

Power supply direction UL
left

Min. ambient temperature
-10 °C

Max. ambient temperature
60 °C

Operational voltage electronics
24 V DC

Electronics voltage tolerance
-20% / +20%

Operating voltage, actuators
24 V DC

Actuator voltage tolerance
-10% / +10%

Total current for actuators
4 A

Protection class
IP65

Total current of sensors max.
4 A

Generic emission standard in accordance with
norm
EN 61000-6-4

Generic immunity standard in accordance with
norm
EN 61000-6-2

Weight
0.15 kg

Material

Housing material
Polyamide fiber-glass reinforced

Part No.
R412018268

Technical information

You will find assignment schemes for the product in the operating instructions, or contact the nearest AVENTICS sales office.

UL: Logic voltage (power supply for electronic components and sensors)

UA: Actuator voltage (power supply for valves and outputs)

The supply voltage is galvanically isolated from the right-hand module.

Dimensions

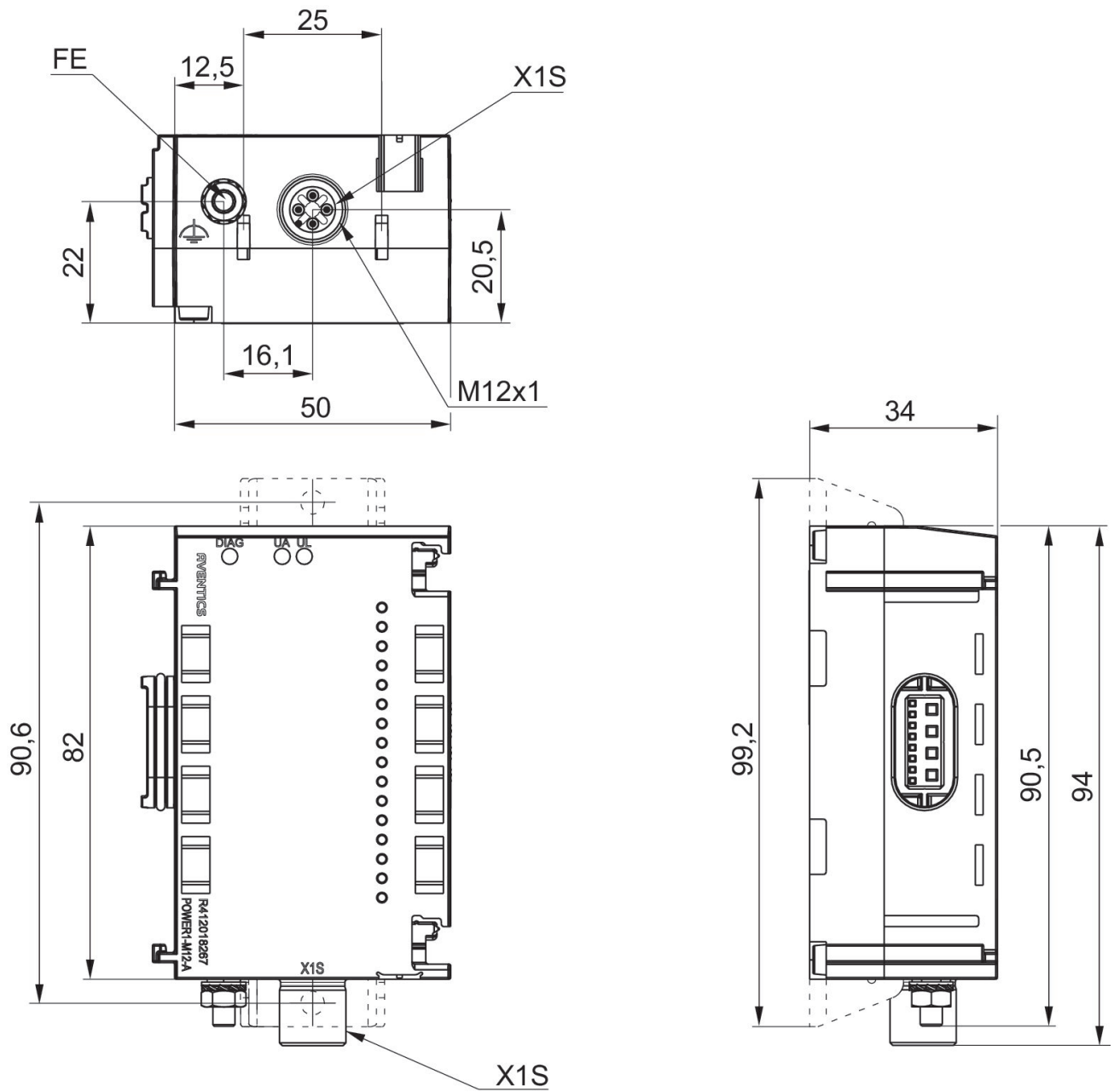

Port 1, X1S

Pin assignments PNP

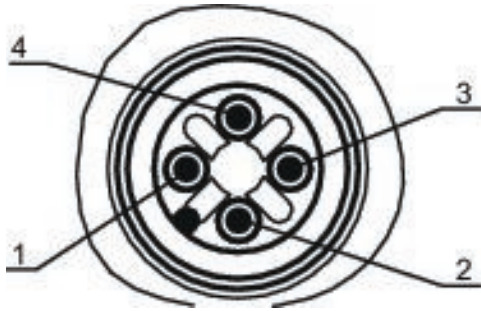

Pin	R412018267 (UA)	R412018267 (UL)
1	-	24 V DC power supply (UL) input
2	24 V DC power supply (UA) input	-
3	-	0 V DC (UL)
4	0 V DC (UA)	-

I/O modules, series AES

R412018277

General series information Series AES

- The AVENTICS Series AES fieldbus connection can be integrated into all AVENTICS fieldbus-compatible valve systems or can also be configured as a stand-alone solution. AES connects your AVENTICS valve system to all relevant fieldbus protocols and offers the integration of I/O-modules and enables optimized decentralized wiring of sensors. The integration of the Digital Twin enables users to be IIoT ready and use the AES to solve their interoperability challenges.



Technical data

Industry
Industrial

Version
I/O modules

Type
2AI2M12-E

E/A capable
connection with I/O

I/O module version
analog inputs/outputs

Number of I/O connections
2 inputs

Power plug IN type
Internal

Signal connection E/A type
Socket

Signal connection E/A thread size
M12x1

Signal connection E/A number of poles
5-pin

Signal connection E/A coding
A-coded

Analog inputs

0 - 10 V / ± 10 V
2 - 10 V / ± 10 V
0 - 20 mA / ± 20 mA
4 - 20 mA / ± 20 mA

Min. ambient temperature
-10 °C

Max. ambient temperature
60 °C

Operational voltage electronics
24 V DC

Max. current per channel
0.5 A

Protection class
IP65

Diagnosis
Short circuit
Undervoltage

Number of inputs
2

Generic emission standard in accordance with
norm
EN 61000-6-4

Generic immunity standard in accordance with
norm
EN 61000-6-2

Weight
0.11 kg

Material

Housing material
Polyamide fiber-glass reinforced

Part No.
R412018277

Technical information

You will find assignment schemes for the product in the operating instructions, or contact the nearest AVENTICS sales office.

The total current of all outputs (including valves) must not exceed 4 A in the overall system.

Voltage and short-circuit monitoring per LED.

The input channels have an input resistance of 120 ohms in the current range and 100 kilohms in the voltage range.

The output channels can drive a maximum ohmic load of 450 ohms in the current range. The minimum resistance in the voltage range is 1 kilohm.

Delivery contents: incl. 2 spring clamp elements and seal
freely selectable signals, configurable

Dimensions

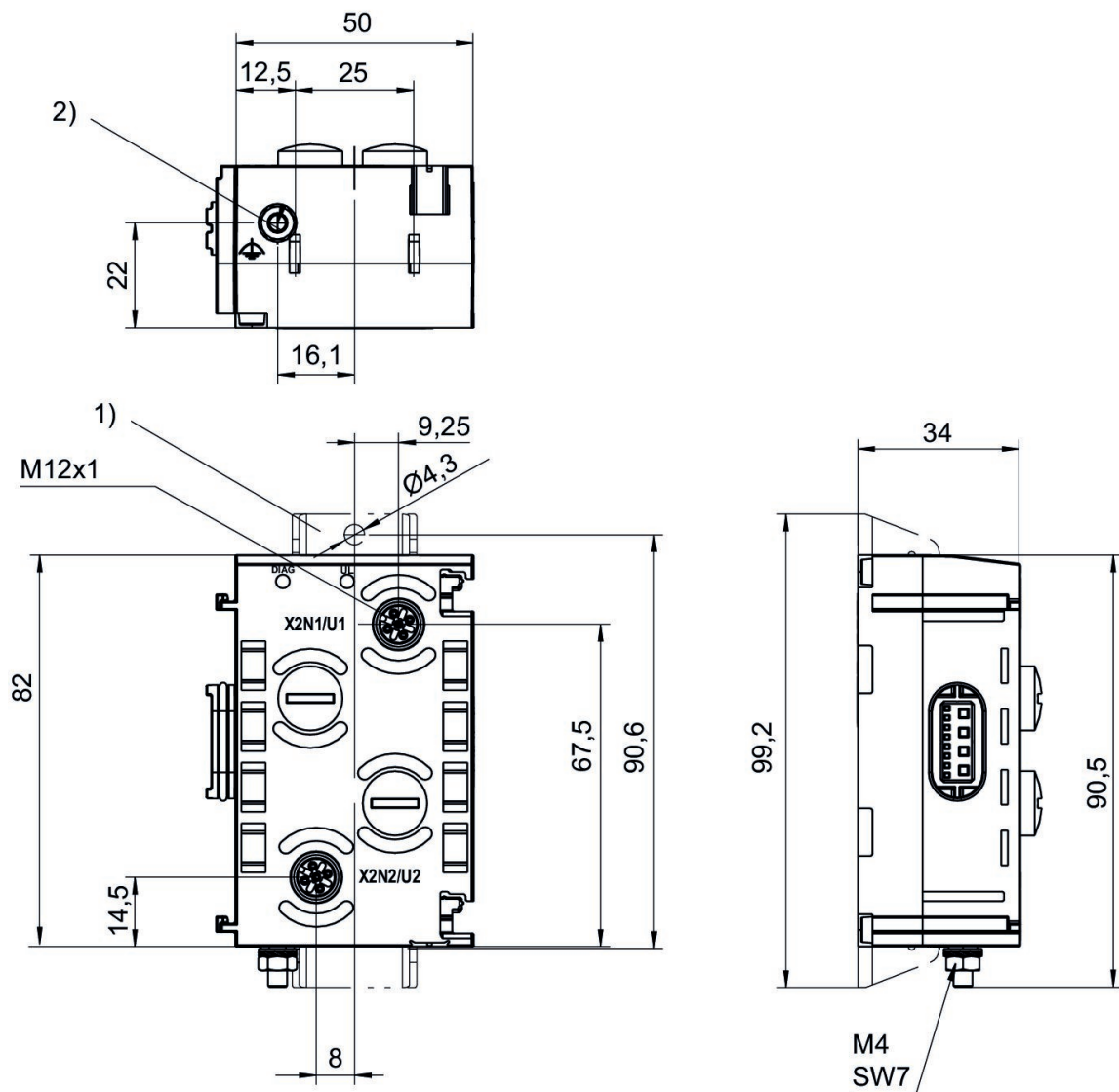

- 1) Retaining bracket (optional)
- 2) Ground

Pin assignments

Socket (female)

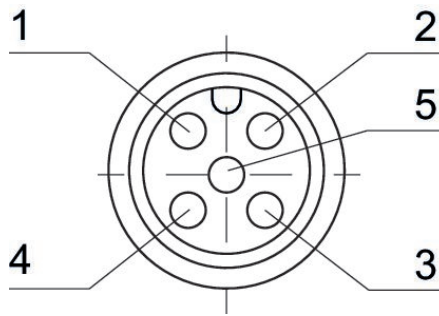

Pin	Socket (female) X2N1 - X2N2 2AI2M12-E	Socket (female) X2U1 - X2U4 4AI4M12-E	Socket (female) X2U1 - X2U2 2AO2M12-E
1	24 V DC	24 V DC	not assigned
2	Input signal (differential input, positive signal)	Input signal (differential input, positive signal)	Output signal
3	0 V DC	0 V DC	0 V DC
4	Input signal (differential input, negative signal, or connected externally to 0 V (pin 3))	Input signal (0 V, connected to pin 3 internally)	not assigned
5	Shield, connected internally with ground screw 2)	Shield, connected internally with ground screw 2)	Shield, connected internally with ground screw 2)

I/O modules, series AES

R412018278

General series information Series AES

- The AVENTICS Series AES fieldbus connection can be integrated into all AVENTICS fieldbus-compatible valve systems or can also be configured as a stand-alone solution. AES connects your AVENTICS valve system to all relevant fieldbus protocols and offers the integration of I/O-modules and enables optimized decentralized wiring of sensors. The integration of the Digital Twin enables users to be IIoT ready and use the AES to solve their interoperability challenges.



Technical data

Industry
Industrial

Version
I/O modules

Type
4AI4M12-E

E/A capable
connection with I/O

I/O module version
analog inputs/outputs

Number of I/O connections
4 inputs

Power plug IN type
Internal

Signal connection E/A type
Socket

Signal connection E/A thread size
M12x1

Signal connection E/A number of poles
5-pin

Signal connection E/A coding
A-coded

Analog inputs

0 ... 10 V
2 - 10 V
0 ... 20 mA
4 ... 20 mA

Min. ambient temperature
-10 °C

Max. ambient temperature
60 °C

Operational voltage electronics
24 V DC

Max. current per channel
0.5 A

Protection class
IP65

Diagnosis
Short circuit
Undervoltage

Number of inputs
4

Generic emission standard in accordance with
norm
EN 61000-6-4

Generic immunity standard in accordance with
norm
EN 61000-6-2

Weight
0.11 kg

Material

Housing material
Polyamide fiber-glass reinforced

Part No.
R412018278

Technical information

You will find assignment schemes for the product in the operating instructions, or contact the nearest AVENTICS sales office.

The total current of all outputs (including valves) must not exceed 4 A in the overall system.

Voltage and short-circuit monitoring per LED.

The input channels have an input resistance of 120 ohms in the current range and 100 kilohms in the voltage range.

The output channels can drive a maximum ohmic load of 450 ohms in the current range. The minimum resistance in the voltage range is 1 kilohm.

The input circuit uses an 8-bit conversion.

Dimensions

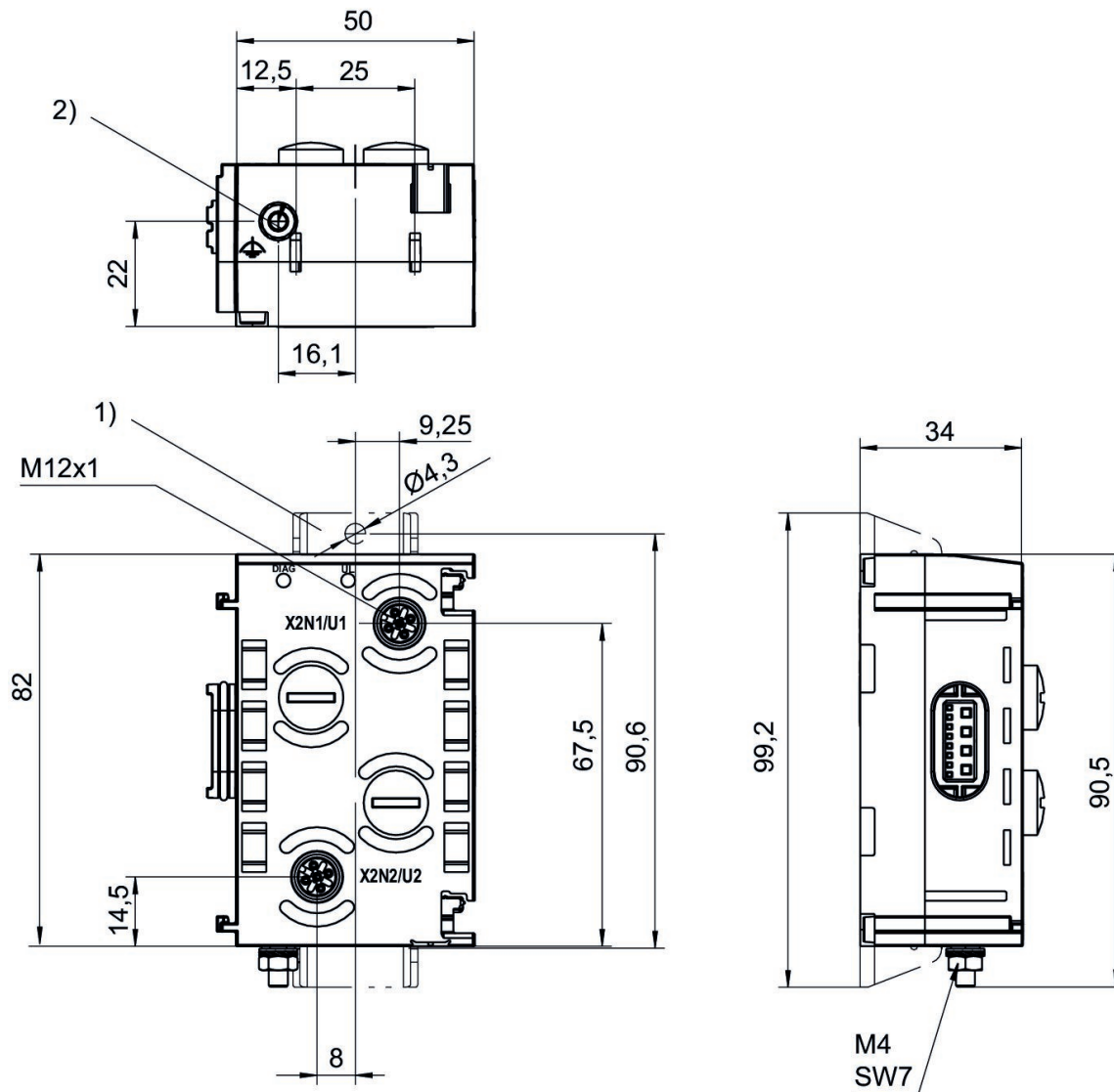

- 1) Retaining bracket (optional)
2) Ground

Pin assignments

Socket (female)

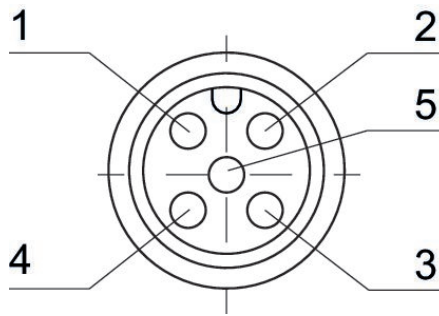

Pin	Socket (female) X2N1 - X2N2 2AI2M12-E	Socket (female) X2U1 - X2U4 4AI4M12-E	Socket (female) X2U1 - X2U2 2AO2M12-E
1	24 V DC	24 V DC	not assigned
2	Input signal (differential input, positive signal)	Input signal (differential input, positive signal)	Output signal
3	0 V DC	0 V DC	0 V DC
4	Input signal (differential input, negative signal, or connected externally to 0 V (pin 3))	Input signal (0 V, connected to pin 3 internally)	not assigned
5	Shield, connected internally with ground screw 2)	Shield, connected internally with ground screw 2)	Shield, connected internally with ground screw 2)

I/O modules, series AES

R412018281

General series information Series AES

- The AVENTICS Series AES fieldbus connection can be integrated into all AVENTICS fieldbus-compatible valve systems or can also be configured as a stand-alone solution. AES connects your AVENTICS valve system to all relevant fieldbus protocols and offers the integration of I/O-modules and enables optimized decentralized wiring of sensors. The integration of the Digital Twin enables users to be IIoT ready and use the AES to solve their interoperability challenges.



Technical data

Industry
Industrial

Version
I/O modules

Type
2AO2M12-E

E/A capable
connection with I/O

I/O module version
analog inputs/outputs

Number of I/O connections
2 outputs

Power plug IN type
Internal

Signal connection E/A type
Socket

Signal connection E/A thread size
M12x1

Signal connection E/A number of poles
5-pin

Signal connection E/A coding
A-coded

Analog outputs

0 - 10 V / ± 10 V

0 ... 20 mA

4 ... 20 mA

Min. ambient temperature

-10 °C

Max. ambient temperature

60 °C

Operational voltage electronics

24 V DC

Max. current per channel

0.5 A

Total current for actuators

4 A

Protection class

IP65

Logic/actuator voltage

Galvanically isolated

Diagnosis

Short circuit

Undervoltage

Number of outputs

2

Generic emission standard in accordance with
norm
EN 61000-6-4

Generic immunity standard in accordance with
norm
EN 61000-6-2
Weight
0.11 kg

Material

Housing material
Polyamide fiber-glass reinforced

Part No.
R412018281

Technical information

You will find assignment schemes for the product in the operating instructions, or contact the nearest AVENTICS sales office.

The total current of all outputs (including valves) must not exceed 4 A in the overall system.

Voltage and short-circuit monitoring per LED.

The input channels have an input resistance of 120 ohms in the current range and 100 kilohms in the voltage range.

The output channels can drive a maximum ohmic load of 450 ohms in the current range. The minimum resistance in the voltage range is 1 kilohm.

Delivery contents: incl. 2 spring clamp elements and seal
freely selectable signals, configurable

Dimensions

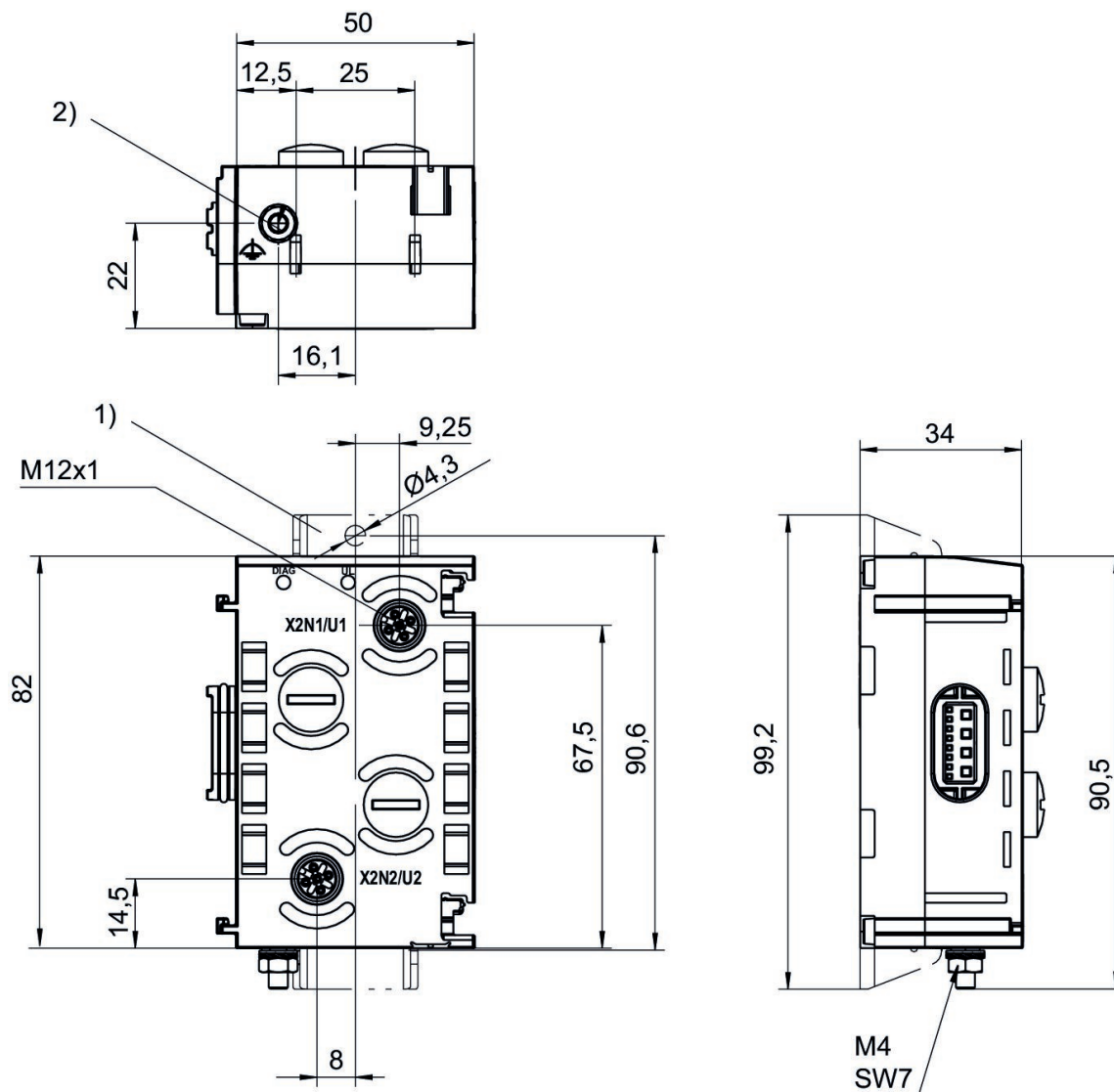

- 1) Retaining bracket (optional)
- 2) Ground

Pin assignments

Socket (female)

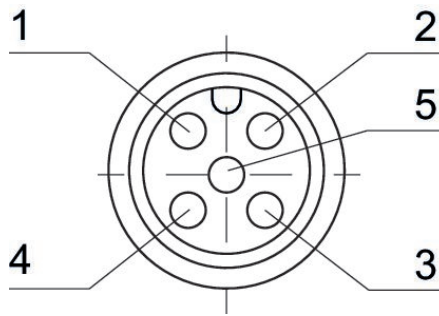

Pin	Socket (female) X2N1 - X2N2 2AI2M12-E	Socket (female) X2U1 - X2U4 4AI4M12-E	Socket (female) X2U1 - X2U2 2AO2M12-E
1	24 V DC	24 V DC	not assigned
2	Input signal (differential input, positive signal)	Input signal (differential input, positive signal)	Output signal
3	0 V DC	0 V DC	0 V DC
4	Input signal (differential input, negative signal, or connected externally to 0 V (pin 3))	Input signal (0 V, connected to pin 3 internally)	not assigned
5	Shield, connected internally with ground screw 2)	Shield, connected internally with ground screw 2)	Shield, connected internally with ground screw 2)

I/O modules, series AES

R412018287

General series information Series AES

- The AVENTICS Series AES fieldbus connection can be integrated into all AVENTICS fieldbus-compatible valve systems or can also be configured as a stand-alone solution. AES connects your AVENTICS valve system to all relevant fieldbus protocols and offers the integration of I/O-modules and enables optimized decentralized wiring of sensors. The integration of the Digital Twin enables users to be IIoT ready and use the AES to solve their interoperability challenges.



Technical data

Industry
Industrial

Version
I/O modules

Type
2AI2AO2M12-AE

E/A capable
connection with I/O

I/O module version
analog inputs/outputs

Number of I/O connections
2 inputs / 2 outputs

Power plug IN type
Plug

Power plug IN size
M12x1

Power plug IN number of pole
4-pin

Signal connection E/A type
Socket

Signal connection E/A thread size
M12x1

Signal connection E/A number of poles
5-pin

Signal connection E/A coding
A-coded

Number of inputs
2

Number of outputs
2

Analog inputs
0 - 10 V / ± 10 V
2 - 10 V / ± 10 V
0 - 20 mA / ± 20 mA
4 - 20 mA / ± 20 mA

Analog outputs
0 - 10 V / ± 10 V
0 ... 20 mA
4 ... 20 mA

Min. ambient temperature
-10 °C

Max. ambient temperature
60 °C

Operational voltage electronics
24 V DC

Max. current per channel 1.2 A	Generic emission standard in accordance with norm EN 61000-6-4
Protection class IP65	Generic immunity standard in accordance with norm EN 61000-6-2
Logic/actuator voltage Galvanically isolated	Weight 0.11 kg
Diagnosis Short circuit Undervoltage	

Material

Housing material Polyamide fiber-glass reinforced	Part No. R412018287
--	------------------------

Technical information

You will find assignment schemes for the product in the operating instructions, or contact the nearest AVENTICS sales office.

The total current of all outputs (including valves) must not exceed 4 A in the overall system.
Suitable for direct connection of an electropneumatic pressure regulator from the ED series.

Delivery contents: incl. 2 spring clamp elements and seal
freely selectable signals, configurable

Dimensions

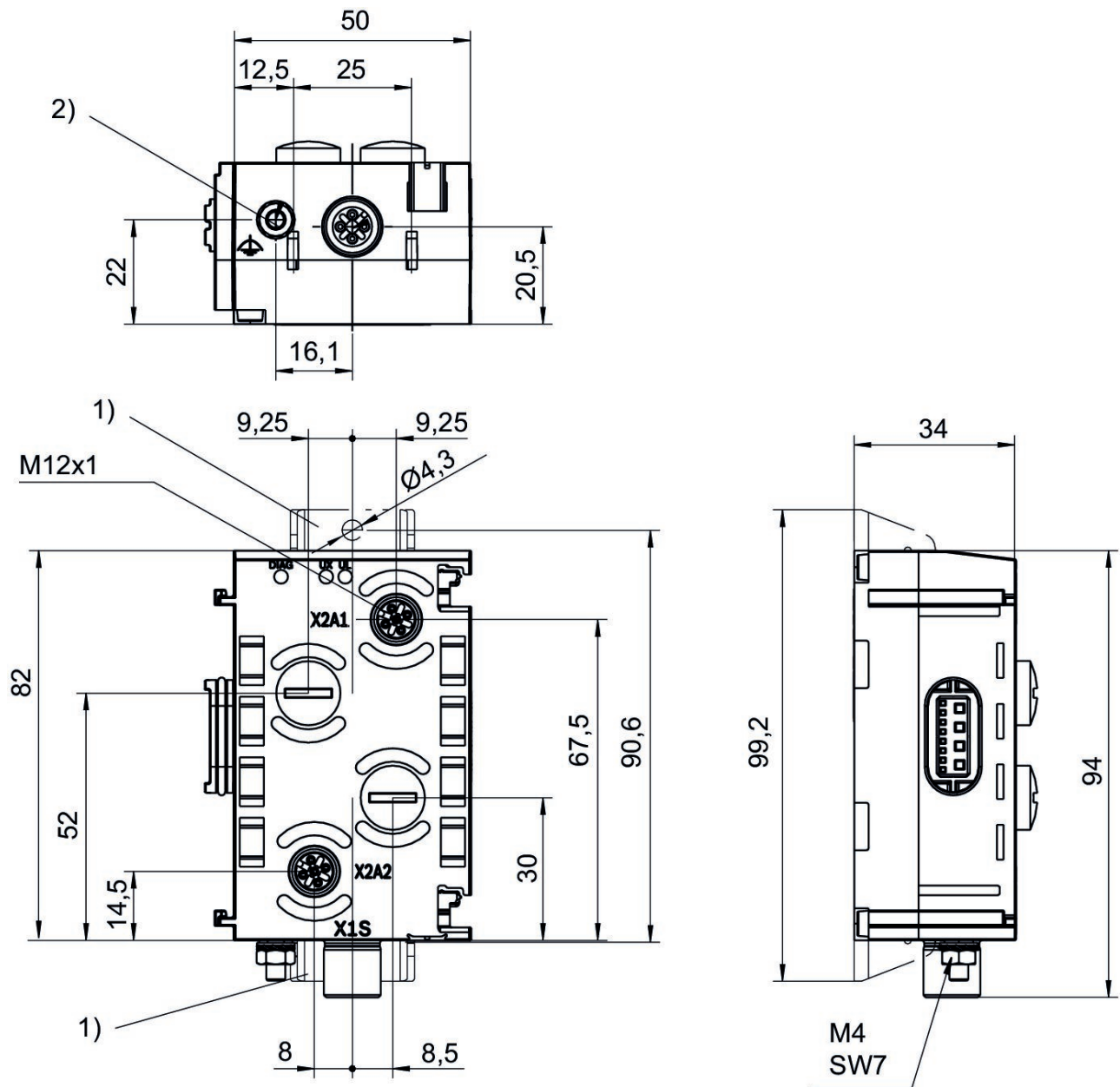

- 1) Retaining bracket (optional)
- 2) Ground

Plug (male)

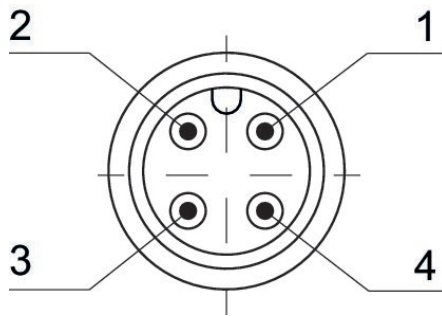

Pin assignments

Socket (female)

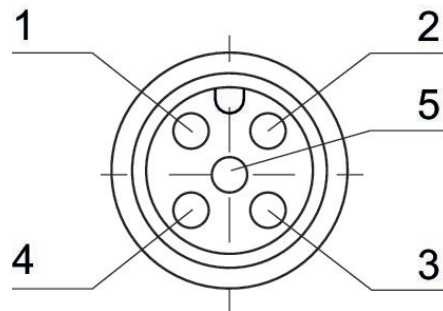

Pin	Socket (female) X2A1 - X2A2	Plug (male) X1S
1	24 V DC	-
2	Output signal	24 V DC
3	0 V DC	-
4	Input signal	0 V DC
5	Shield, connected internally with ground screw 2)	-

I/O modules, series AES

R412018293

General series information Series AES

- The AVENTICS Series AES fieldbus connection can be integrated into all AVENTICS fieldbus-compatible valve systems or can also be configured as a stand-alone solution. AES connects your AVENTICS valve system to all relevant fieldbus protocols and offers the integration of I/O-modules and enables optimized decentralized wiring of sensors. The integration of the Digital Twin enables users to be IIoT ready and use the AES to solve their interoperability challenges.



Technical data

Industry
Industrial

Version
I/O modules

Type
2AI2AO2M12-C

Note
control module M12x1, 5-pin / with external power supply /
control of E/P pressure regulators / position control /
superordinate control

E/A capable
connection with I/O

I/O module version
analog inputs/outputs

Number of I/O connections
2 inputs / 2 outputs

Power plug IN type
Plug

Power plug IN size
M12x1

Power plug IN number of pole
4-pin

Signal connection E/A type
Socket

Signal connection E/A thread size
M12x1

Signal connection E/A number of poles
5-pin

Signal connection E/A coding
A-coded

Analog inputs
0 - 10 V / ± 10 V
2 - 10 V / ± 10 V
0 - 20 mA / ± 20 mA
4 - 20 mA / ± 20 mA

Analog outputs
0 - 10 V / ± 10 V
0 ... 20 mA
4 ... 20 mA

Min. ambient temperature
-10 °C

Max. ambient temperature
60 °C

Operational voltage electronics
24 V DC

Total current for actuators 4 A	Generic emission standard in accordance with norm EN 61000-6-4
Protection class IP65	Generic immunity standard in accordance with norm EN 61000-6-2
Logic/actuator voltage Galvanically isolated	Weight 0.11 kg
Diagnosis Short circuit Undervoltage	

Material

Housing material Polyamide fiber-glass reinforced	Part No. R412018293
--	------------------------

Technical information

Information on the assignment scheme and control parameters can be found in the operating instructions. Or, contact your nearest AVENTICS sales office.

The total current of all outputs (including valves) must not exceed 4 A in the overall system.

After direct connection to an electropneumatic pressure regulator suitable for controlling positions or superior control circuits.

Suitable for direct connection of an electropneumatic pressure regulator from the ED series.

Delivery contents: incl. 2 spring clamp elements and seal
freely selectable signals, configurable

Dimensions

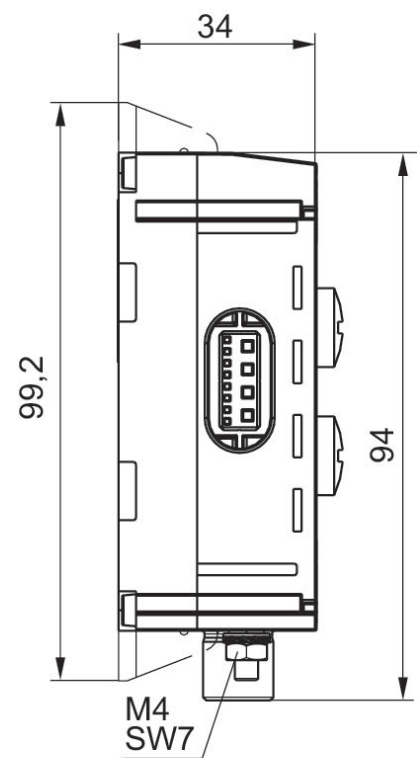
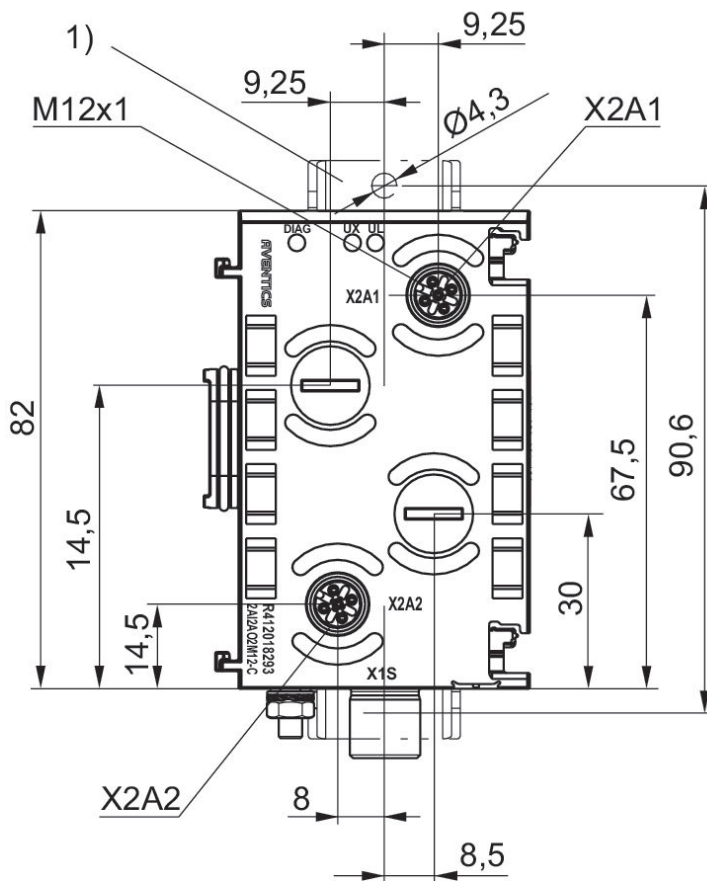
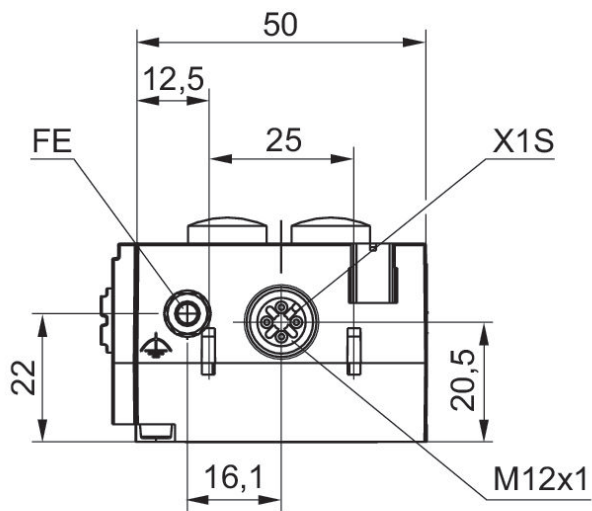

1) Retaining bracket (optional)

Pin assignments

Socket (female)

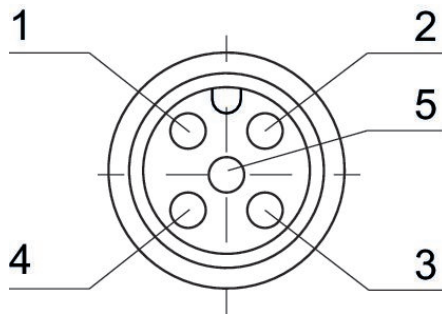

Pin	Socket (female) X2A1 - X2A2	Plug (male) X1S
1	24 V DC	-
2	Output signal	24 V DC
3	0 V DC	-
4	Input signal	0 V DC
5	Shield, connected internally with ground screw 2)	-

I/O modules, series AES

R412018252

General series information Series AES

- The AVENTICS Series AES fieldbus connection can be integrated into all AVENTICS fieldbus-compatible valve systems or can also be configured as a stand-alone solution. AES connects your AVENTICS valve system to all relevant fieldbus protocols and offers the integration of I/O-modules and enables optimized decentralized wiring of sensors. The integration of the Digital Twin enables users to be IIoT ready and use the AES to solve their interoperability challenges.



Technical data

Industry
Industrial

Version
I/O modules

Type
16DO32SC

E/A capable
connection with I/O

I/O module version
digital outputs

Number of I/O connections
16 outputs

Power plug IN type
Internal

Signal connection E/A type
Spring clamp connections

Min. ambient temperature
-10 °C

Max. ambient temperature
60 °C

Operational voltage electronics
24 V DC

Electronics voltage tolerance
-25% / +25%

Max. current per channel
0.5 A

Total current for actuators
4 A

Protection class
IP20

Logic/actuator voltage
Galvanically isolated

Diagnosis
Short circuit

Generic emission standard in accordance with
norm

EN 61000-6-4

Generic immunity standard in accordance with
norm

EN 61000-6-2

Weight
0.115 kg

Material

Housing material
Polyamide fiber-glass reinforced

Part No.
R412018252

Technical information

You will find assignment schemes for the product in the operating instructions, or contact the nearest AVENTICS sales office.

The total current of all outputs (including valves) must not exceed 4 A in the overall system.

Voltage and short-circuit monitoring per LED.

The clamp area for stranded wires is between 0.2 and 1.5 mm².

Delivery contents: incl. 2 spring clamp elements and seal

Dimensions

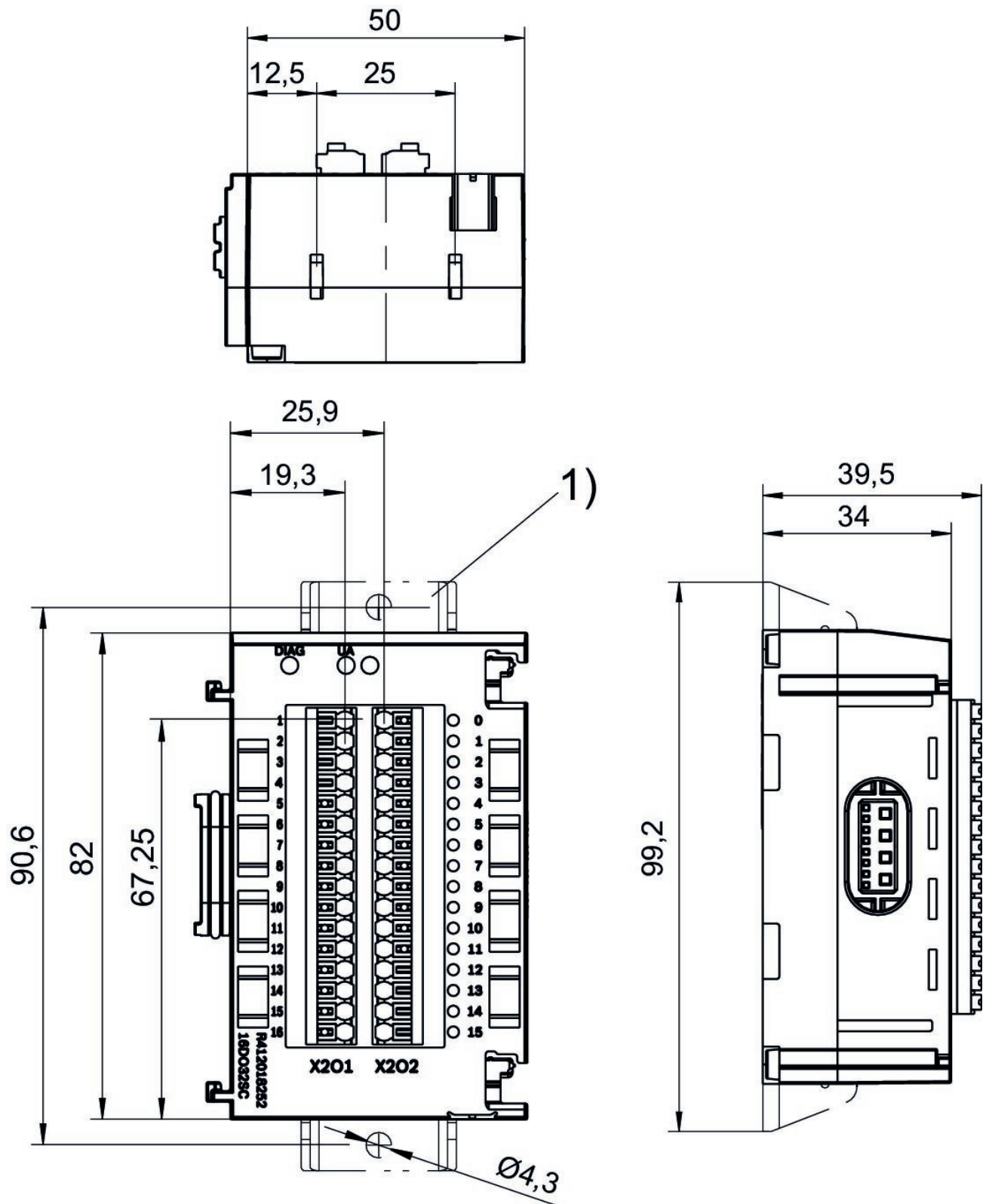

1) Retaining bracket (optional)

Port	Contact	Function
X201	1	Output signal 24 V DC bit 0.0
2	Output signal 24 V DC bit 0.1	
3	Output signal 24 V DC bit 0.2	
4	Output signal 24 V DC bit 0.3	
5	Output signal 24 V DC bit 0.4	
6	Output signal 24 V DC bit 0.5	
7	Output signal 24 V DC bit 0.6	
8	Output signal 24 V DC bit 0.7	
9	Output signal 24 V DC bit 1.0	
10	Output signal 24 V DC bit 1.1	
11	Output signal 24 V DC bit 1.2	
12	Output signal 24 V DC bit 1.3	
13	Output signal 24 V DC bit 1.4	
14	Output signal 24 V DC bit 1.5	
15	Output signal 24 V DC bit 1.6	
16	Output signal 24 V DC bit 1.7	

I/O modules, series AES

R412018291

General series information



Technical data

Industry
Industrial

Version
I/O modules

Type
4P4D4

port pneumatic
D4

Note
Pressure measurement module with 4 compressed air connection

E/A capable
connection with I/O

I/O module version
analog inputs

Number of I/O connections
4 inputs

Power plug IN type
Internal

Min. ambient temperature
-10 °C

Max. ambient temperature
60 °C

Working pressure max
10 bar

Measurement min.
0 bar

Measurement max.
10 bar

Protection class
IP65

Generic emission standard in accordance with
norm
EN 61000-6-4

Generic immunity standard in accordance with
norm
EN 61000-6-2

Weight
0.115 kg

Material

Housing material
Polyamide fiber-glass reinforced

Part No.
R412018291

Technical information

When using polyurethane tubing, we recommend using additional stiffener sleeves.

For push-in fittings, only use plug accessories made of plastic (polyamide) from our catalog.

The pressure dew point must be at least 15 °C under ambient and medium temperature and may not exceed 3 °C .

I/O modules, series AES

R412018292

General series information



Technical data

Industry
Industrial

Version
I/O modules

Type
4VP4D4

port pneumatic
D4

Note
Pressure measurement module with 4 compressed air connection

E/A capable
connection with I/O

I/O module version
analog inputs

Number of I/O connections
4 inputs

Power plug IN type
Internal

Min. ambient temperature
-10 °C

Max. ambient temperature
60 °C

Working pressure max
1 bar

Measurement min.
-1 bar

Measurement max.
1 bar

Protection class
IP65

Generic emission standard in accordance with
norm
EN 61000-6-4

Generic immunity standard in accordance with
norm
EN 61000-6-2

Weight
0.115 kg

Material

Housing material
Polyamide fiber-glass reinforced

Part No.
R412018292

Technical information

When using polyurethane tubing, we recommend using additional stiffener sleeves.

For push-in fittings, only use plug accessories made of plastic (polyamide) from our catalog.

The pressure dew point must be at least 15 °C under ambient and medium temperature and may not exceed 3 °C .

Dimensions

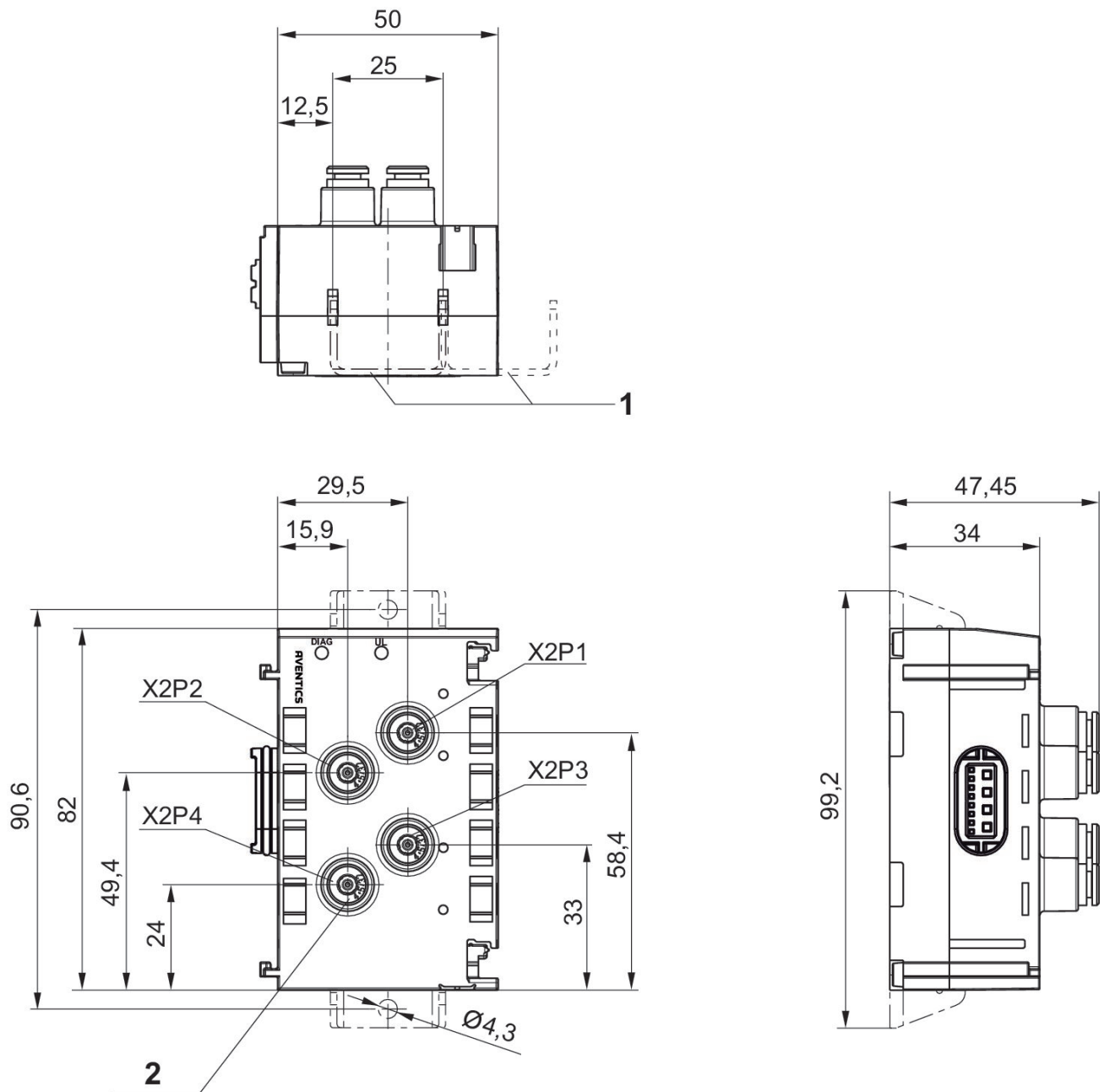

- 1) Retaining bracket (optional)
- 2) Blanking plug included in scope of delivery

Power module Series AES

R412018272

General series information Series AES

- The AVENTICS Series AES fieldbus connection can be integrated into all AVENTICS fieldbus-compatible valve systems or can also be configured as a stand-alone solution. AES connects your AVENTICS valve system to all relevant fieldbus protocols and offers the integration of I/O-modules and enables optimized decentralized wiring of sensors. The integration of the Digital Twin enables users to be IIoT ready and use the AES to solve their interoperability challenges.



Technical data

Industry
Industrial

Version
Power module

E/A capable
connection with I/O

Power plug IN type
Plug

Power plug IN size
7/8"-16UNF

Power plug IN number of pole
5-pin

Power plug OUT type
Socket

Power plug OUT size
7/8"-16UNF

Power plug OUT number of pole
5-pin

Power supply direction UA/UL
left, right

Min. ambient temperature
-10 °C

Max. ambient temperature
60 °C

Operational voltage electronics
24 V DC

Electronics voltage tolerance
-20% / +20%

Operating voltage, actuators
24 V DC

Actuator voltage tolerance
-10% / +10%

Total current for actuators
4 A

Protection class
IP65

Total current of sensors max.
4 A

Generic emission standard in accordance with
norm
EN 61000-6-4

Generic immunity standard in accordance with
norm
EN 61000-6-2

Weight
0.15 kg

Material

Housing material
Polyamide fiber-glass reinforced

Part No.
R412018272

Technical information

You will find assignment schemes for the product in the operating instructions, or contact the nearest AVENTICS sales office.

The supply voltage from X1S1 is available at X1S2 (without modification)

The total internal current (UA or UL) and consumption at X1S2 must not exceed 8A at X1S1.

UL: Logic voltage (power supply for electronic components and sensors)

UA: Actuator voltage (power supply for valves and outputs)

If connection 2 is not used for forwarding, it must be closed with sealing cap R412024838.

Power plug X1S on the bus coupler must be closed with sealing cap R412024837.

Dimensions

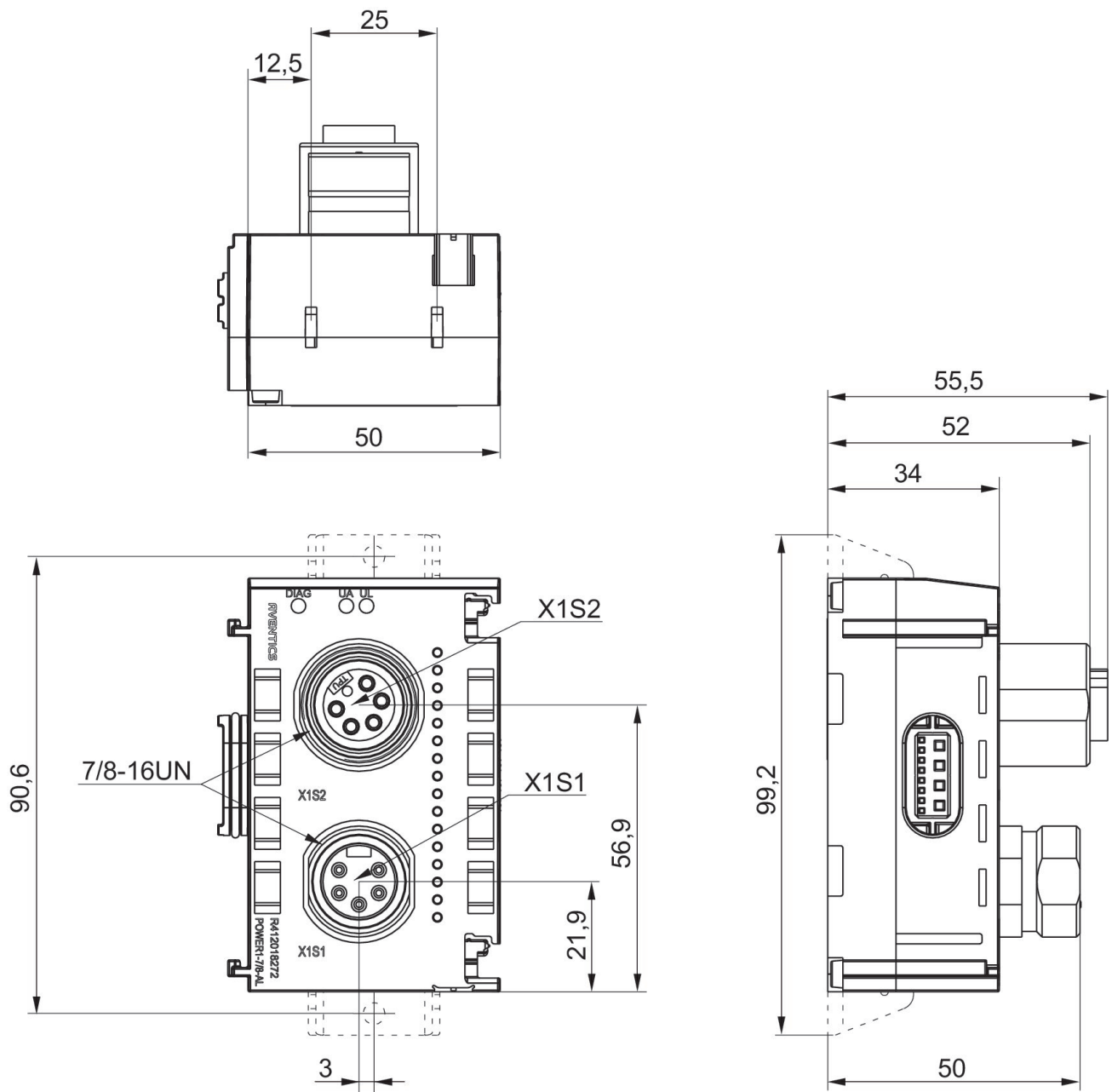

Port 1, X1S1
Port 2, X1S2

Pin assignments PNP

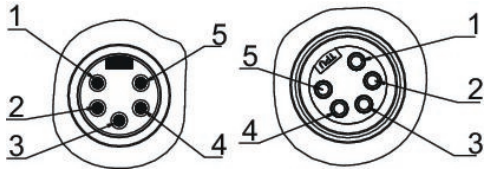

Pin	Plug X1S1	Socket X1S2
1	0 V DC (UA)	0 V DC (UA)
2	0 V DC (UL)	0 V DC (UL)
3	FE	FE
4	24 V DC power supply (UL) input	24 V DC power supply (UL) output
5	24 V DC power supply (UA) input	24 V DC power supply (UA) output

Exhaust module, for port channels 2, 4



Working pressure min./max.	0 ... 10 bar
Ambient temperature min./max.	-10 ... 60 °C
Medium	Compressed air
Weight	0.08 kg

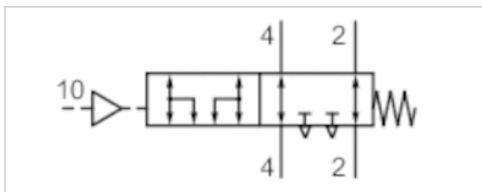

Technical data

Part No.	Port 1 Input	Compressed air connection Output	Flow Qn
R422003188	Ø 4	Ø 4	280 l/min
R422003186	Ø 6	Ø 6	720 l/min
R422003118	Ø 8	Ø 8	1080 l/min

Technical information

When using polyurethane tubing, we recommend using additional stiffener sleeves. Particularly suitable for 5/3 CC valves, since the remaining pressure in the actuator can be exhausted when the control pressure is applied. The exhaust module and the air circuit should be tested monthly to ensure they function correctly. Applications with vertical actuators with exhaust or pressure throttles and a maximum load of 15 kg as well as up to a speed of Vmax 33 mm/s .

Technical information

Material	
Housing	Aluminum
Seals	Nitrile rubber

Dimensions

Dimensions

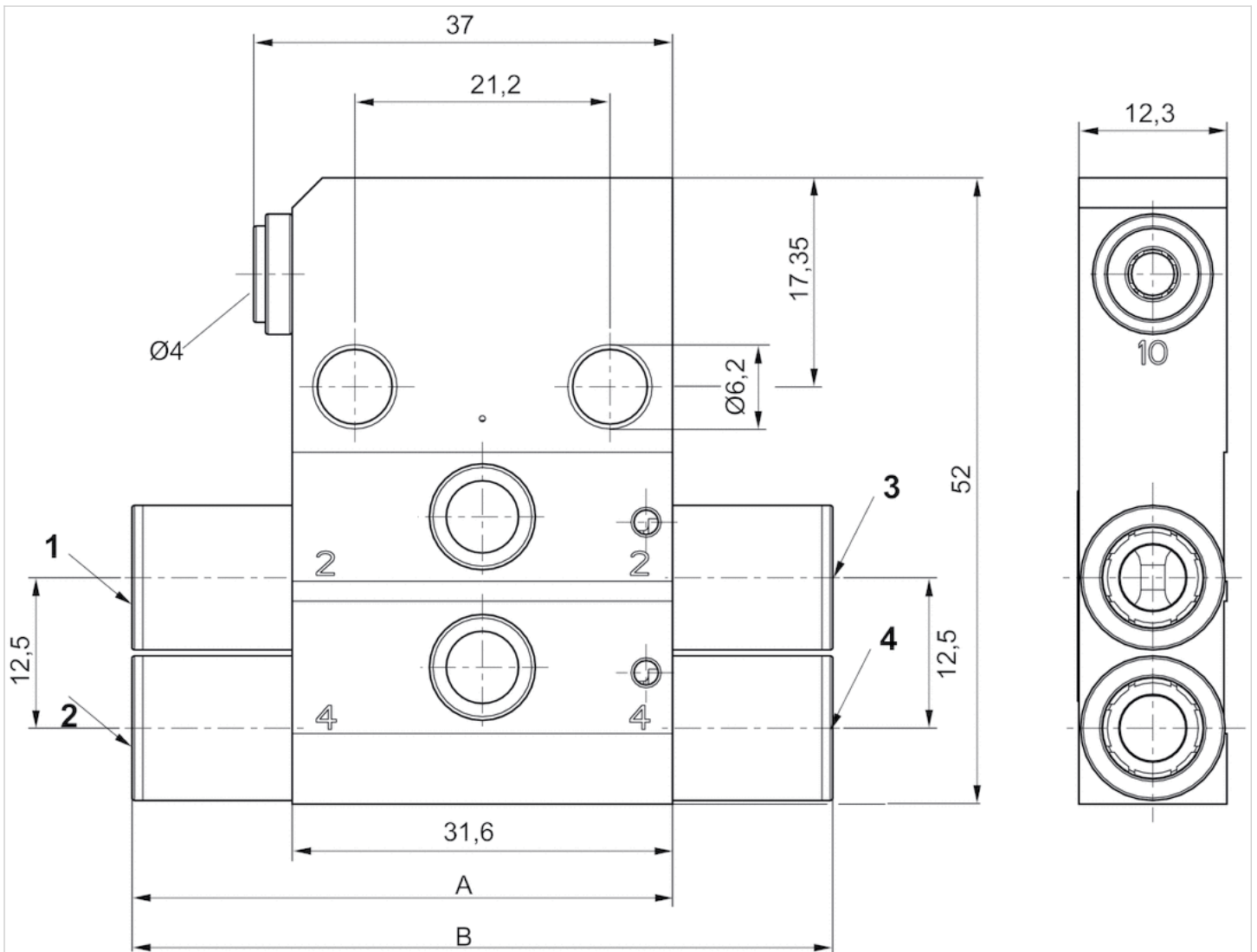

- 1) Connection 2, valve side
- 2) Connection 4, valve side
- 3) Operating line 2
- 4) Operating line 4

Dimensions

Part No.	2 (NI/min±15%)	4 (NI/min±15%)	A	B
R422003188	280	300	38	42
R422003186	720	790	42	50
R422003118	1080	1400	46	58

Diagrams

Minimum control pressure (depending on operating pressure)

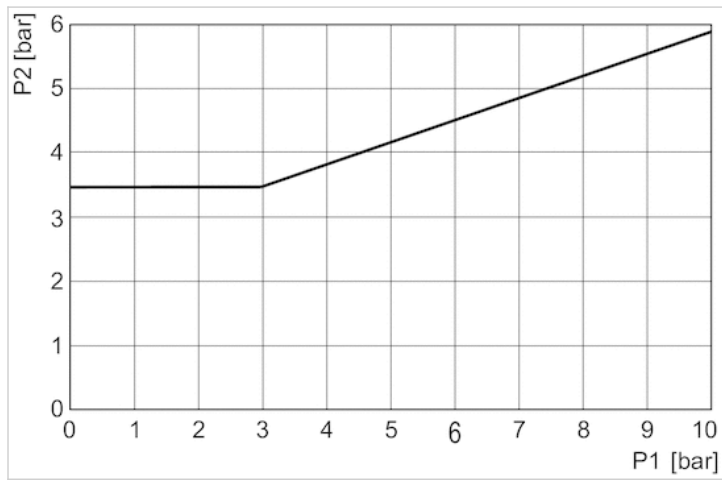

p1 = pressure on connections 2 and 4, p2 = control pressure

Pressure regulator subplate, Series HF04

- for series HF04, HF04-XF, LP04
 - Poppet valve

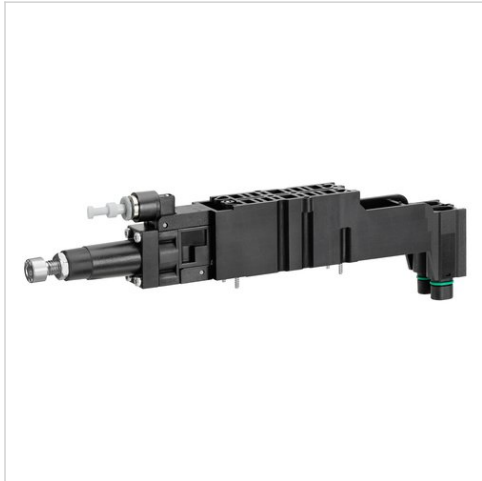

Version	Poppet valve
Working pressure min./max.	0.5 ... 10 bar
Adjustment range min./max.	See table below
Ambient temperature min./max.	-5 ... 50 °C
Medium temperature min./max.	0 ... 50 °C
Medium	Compressed air
Max. particle size	5 µm
Oil content of compressed air	0 ... 5 mg/m ³
Weight	0.1 kg

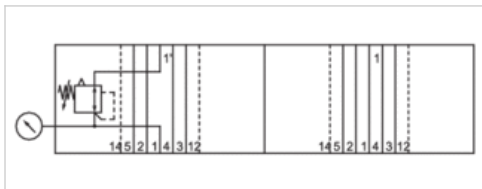

Technical data

Part No.	Adjustment range min./max.	Fig.
R412000999	0.5 ... 8 bar	Fig. 1
R412008584	0.5 ... 4 bar	Fig. 2

Pressure gauge, 0-1 MPa, with 4 mm push-in fitting.

Technical information

Protection class when mounted: IP65

Please note that HF04 and LP03 series valve systems can only be retrofitted without conversion from 05/2008 onwards. Older valve systems do not have the required mounting holes in the subbases.

Technical information

Material	
Housing	Polyamide
Seals	Acrylonitrile butadiene rubber

Dimensions

Dimensions

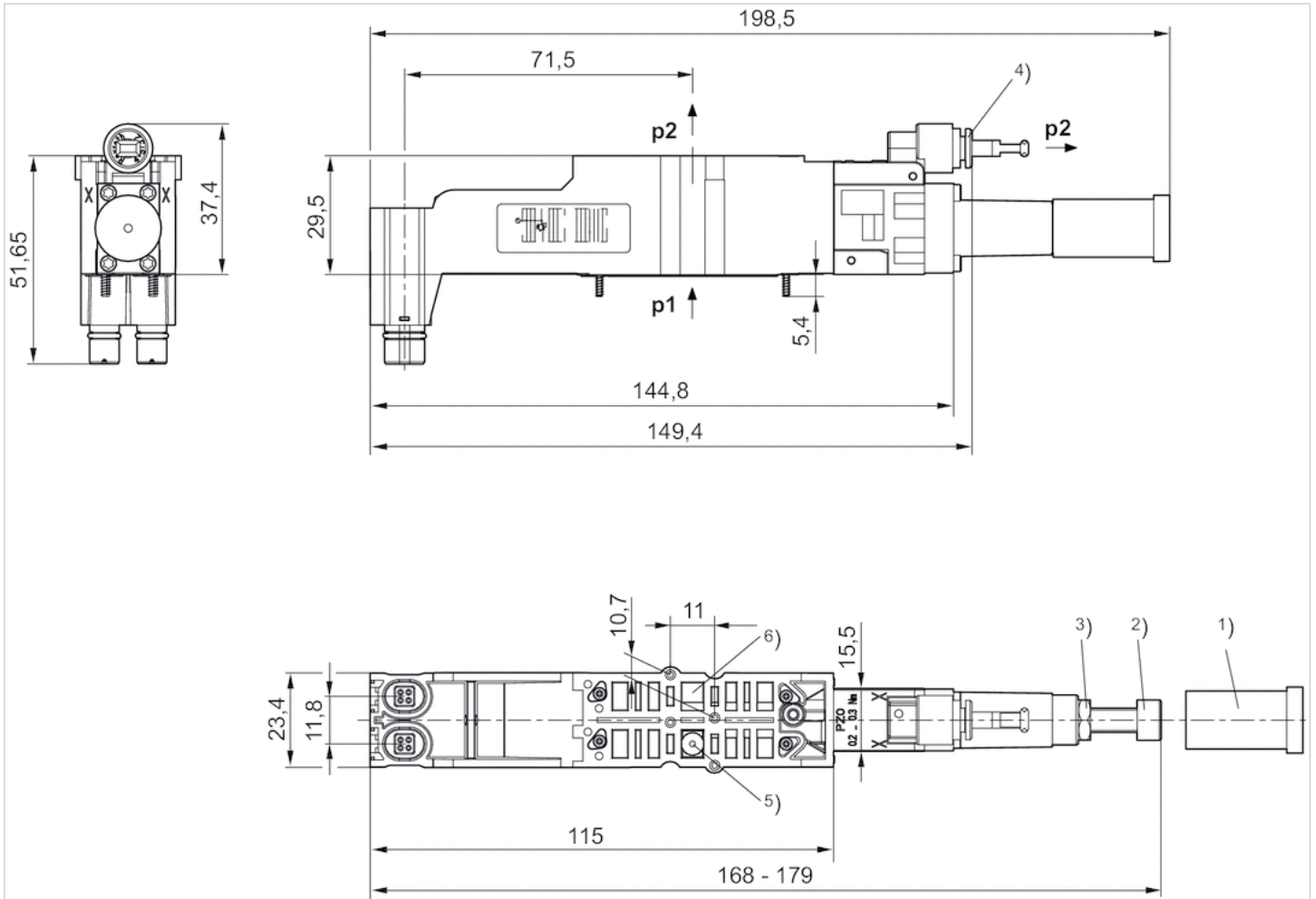

- 1) Locking cap 2) Regulating screw 3) Lock nut 4) Push-in fitting
- p1 = working pressure p2 = secondary pressure
- 5) Valve position is controlled by the pressure regulator subplate
- 6) Valve position is directly supplied via channel 1 of the valve system

Diagrams

Fig. 1

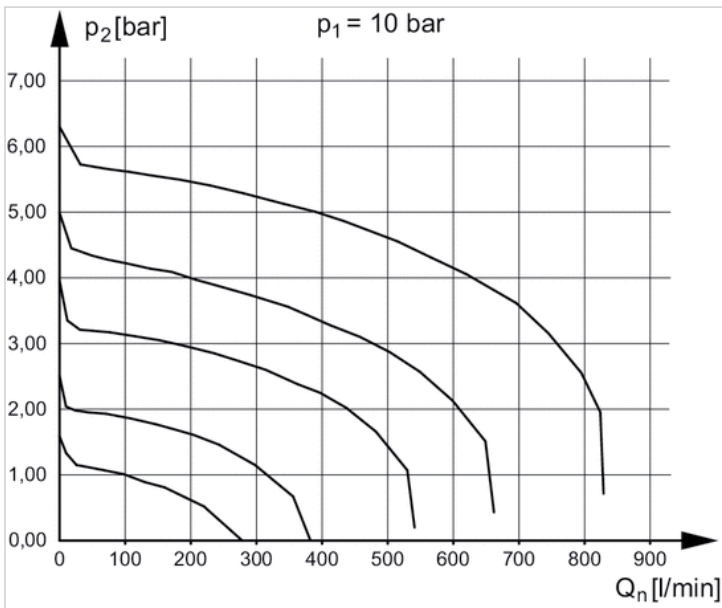

p1 = Working pressure
 p2 = Secondary pressure
 qn = Nominal flow

Fig. 2

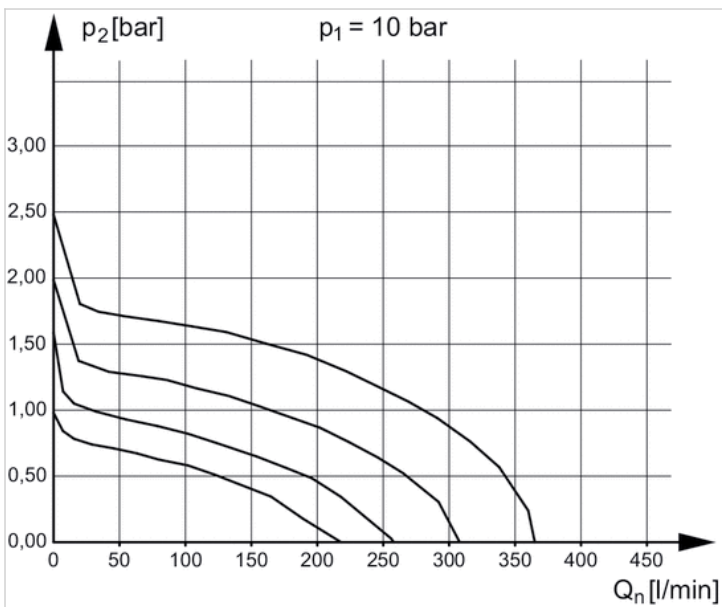

p1 = Working pressure
 p2 = Secondary pressure
 qn = Nominal flow

Pressure gauge, Series PG1-ROB

- Back port
- Background color Black
- Scale color White
- Viewing window Polystyrene
- Units MPa



Version	Bourdon tube pressure gauge
Medium	Compressed air Compressed air
Main scale unit (outside)	MPa
Main scale color (outside)	White
Background color	Black
Pointer color	Red
Weight	0.01 kg

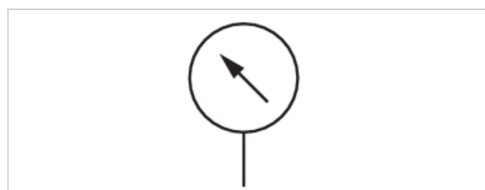

Technical data

Part No.	Compressed air connection	Nominal diameter	Range of application	Display range
R412009413	Ø 4	15 mm	0 ... 10 bar	0 ... 10 bar

Technical information

Material	
Housing	Acrylonitrile butadiene styrene
Thread	Brass
Viewing window	Polystyrene
Seal	Polytetrafluorethylene

Dimensions

Dimensions in mm

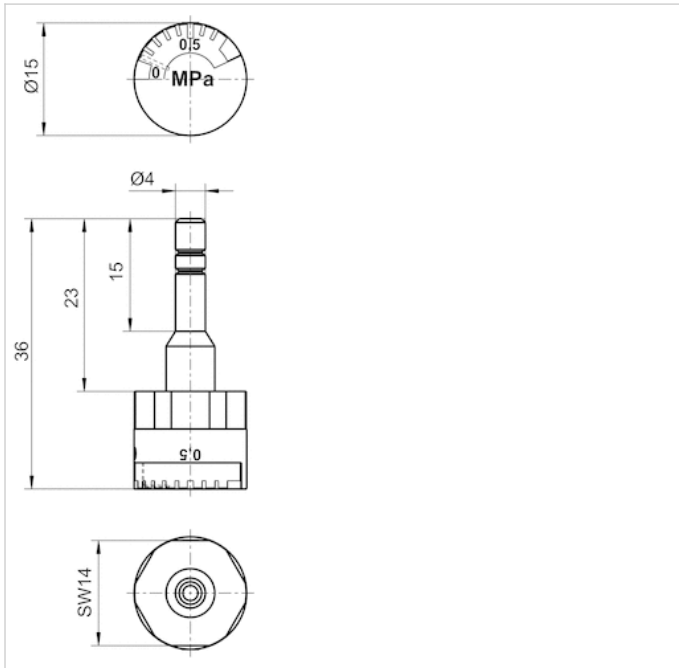

CKD kit, Series HF04

- Compressed air connection output Ø 6 M7
- Can be assembled into blocks
- Double base plate principle
- Reversed pressure supply permissible
- Bus module extension possible
- I/O extension possible
- With collective pilot air exhaust
- D-Sub plug, 25-pin, on the side Link structure CMS



Version	Multipole
Working pressure min./max.	See table below
Ambient temperature min./max.	-5 ... 50 °C
Medium temperature min./max.	0 ... 50 °C
Medium electr. connection	Compressed air
	D-Sub plug, 25-pin, on the side Link structure CMS
Number of valve positions max.	2
Grid dimension	11.8 mm
Rail mounting DIN EN 60715	TH35 x 15
Exhaust (3,5)	With directional exhaust (3/5)
Exhaust type	Ports separated
Mounting screw	cross recessed DIN EN ISO 4757-Z0
Tightening torque for mounting screws	0.2 Nm

Technical data

Part No.	Type	electrical connections
R412008545	Base plate for a single or double solenoid valve	Plug, D-Sub, 25-pin
R412008546	Base plate for a single or double solenoid valve	Plug, D-Sub, 25-pin
R412008547	Base plate for a single or double solenoid valve	Plug, D-Sub, 25-pin
R412008548	Base plate for a single or double solenoid valve	Plug, D-Sub, 25-pin

Part No.	Compressed air connection Input [1]	Compressed air connection Output [2 / 4]
R412008545	Ø 8	Ø 6
R412008546	Ø 8	Ø 6
R412008547	Ø 8	M7
R412008548	Ø 8	M7

Part No.	Compressed air connection Exhaust [3 / 5]	Compressed air connection Pilot connection [X]
R412008545	Ø 10	-
R412008546	Ø 10	Ø 6
R412008547	Ø 10	-
R412008548	Ø 10	Ø 6

Part No.	Compressed air connection Pilot control exhaust [R]	Working pressure min./max.	Pilot
R412008545	Ø 6	3 ... 8 bar	Internal
R412008546	Ø 6	-0.9 ... 10 bar	External
R412008547	Ø 6	3 ... 8 bar	Internal
R412008548	Ø 6	-0.9 ... 10 bar	External

Part No.	DC operating voltage	Voltage tolerance DC
R412008545	24 V	-10% / +10%
R412008546	24 V	-10% / +10%
R412008547	24 V	-10% / +10%
R412008548	24 V	-10% / +10%

1 = plug-in connection Ø 8 mm↔2 and 4 = plug-in connection Ø 6 mm or thread connections M7↔3 and 5 = plug-in connection Ø 10 mm↔R = collected pilot exhaust, plug-in connection Ø 6 mm↔X = external pilot, plug-in connection Ø 6 mm, connection X plugged with internal pilot control

Technical information

The min. control pressure must be adhered to, since otherwise faulty switching and valve failure may result!

The pressure dew point must be at least 15 °C under ambient and medium temperature and may not exceed 3 °C .

The oil content of compressed air must remain constant during the life cycle.

Use only the approved oils from AVENTICS. Further information can be found in the "Technical information" document (available in the MediaCentre).

Double base plate principle

Technical information

Material	
Base plate	Polyamide
push-in fitting	Brass, nickel-plated
Seal	Acrylonitrile butadiene rubber
Screws	Steel
Tie-rods	Aluminum

CKD kit, Series HF04

- Inch version
- Compressed air connection output M7
- Can be assembled into blocks
- Double base plate principle
- Reversed pressure supply permissible
- Bus module extension possible
- I/O extension possible
- With collective pilot air exhaust
- D-Sub plug, 25-pin, on the side Link structure CMS



Version	Multipole
Working pressure min./max.	See table below
Ambient temperature min./max.	-5 ... 50 °C
Medium temperature min./max.	0 ... 50 °C
Medium electr. connection	Compressed air D-Sub plug, 25-pin, on the side Link structure CMS
Number of valve positions max.	2
Grid dimension	11.8 mm
Rail mounting DIN EN 60715	TH35 x 15
Exhaust (3,5)	With directional exhaust (3/5)
Exhaust type	Ports separated
Mounting screw	cross recessed DIN EN ISO 4757-Z0
Tightening torque for mounting screws	0.2 Nm

Technical data

Part No.	Type	electrical connections
R412008549	Base plate for a single or double solenoid valve	Plug, D-Sub, 25-pin
R412008550	Base plate for a single or double solenoid valve	Plug, D-Sub, 25-pin

Part No.	Compressed air connection Input [1]	Compressed air connection Output [2 / 4]
R412008549	3/8"	M7
R412008550	3/8"	M7

Part No.	Compressed air connection Exhaust [3 / 5]	Compressed air connection Pilot connection [X]
R412008549	3/8"	-
R412008550	3/8"	Ø 1/4"

Part No.	Compressed air connection Pilot control exhaust [R]	Working pressure min./max.	Pilot
R412008549	Ø 1/4"	3 ... 8 bar	Internal
R412008550	Ø 1/4"	-0.9 ... 10 bar	External

Part No.	DC operating voltage	Voltage tolerance DC
R412008549	24 V	-10% / +10%
R412008550	24 V	-10% / +10%

1 = plug-in connection 3/8" (inch)↔2 and 4 = thread connections M7↔3 and 5 = plug-in connection 3/8" (inch)↔R = collected pilot exhaust, plug-in connection 1/4" (inch)↔X = external pilot, plug-in connection 1/4" (inch), connection X plugged with internal pilot control

Technical information

The min. control pressure must be adhered to, since otherwise faulty switching and valve failure may result!

The pressure dew point must be at least 15 °C under ambient and medium temperature and may not exceed 3 °C .

The oil content of compressed air must remain constant during the life cycle.

Use only the approved oils from AVENTICS. Further information can be found in the "Technical information" document (available in the MediaCentre).

Double base plate principle

Technical information

Material	
Base plate	Polyamide
push-in fitting	Brass, nickel-plated
Seal	Acrylonitrile butadiene rubber
Screws	Steel
Tie-rods	Aluminum

CKD kit, Series HF04-XF

- Compressed air connection output \varnothing 6
- Can be assembled into blocks
- Double base plate principle
- Reversed pressure supply permissible
- Bus module extension possible
- I/O extension possible
- With collective pilot air exhaust
- D-Sub plug, 44-pin, on the side Link structure CMS



Version	Multipole
Working pressure min./max.	See table below
Ambient temperature min./max.	-5 ... 50 °C
Medium temperature min./max.	0 ... 50 °C
Medium electr. connection	Compressed air
	D-Sub plug, 44-pin, on the side Link structure CMS
Number of valve positions max.	2
Grid dimension	11.8 mm
Rail mounting DIN EN 60715	TH35 x 15
Exhaust (3,5)	With directional exhaust (3/5)
Exhaust type	Ports separated
Mounting screw	cross recessed DIN EN ISO 4757-Z0
Tightening torque for mounting screws	0.2 Nm

Technical data

Part No.	Type	electrical connections
R412012796	Base plate for a single or double solenoid valve	Plug, D-Sub, 44-pin
R412012797	Base plate for a single or double solenoid valve	Plug, D-Sub, 44-pin

Part No.	Compressed air connection Input [1]	Compressed air connection Output [2 / 4]
R412012796	\varnothing 8	\varnothing 6
R412012797	\varnothing 8	\varnothing 6

Part No.	Compressed air connection Exhaust [3 / 5]	Compressed air connection Pilot connection [X]
R412012796	\varnothing 10	-
R412012797	\varnothing 10	\varnothing 6

Part No.	Compressed air connection Pilot control exhaust [R]	Working pressure min./max.	Pilot
R412012796	\varnothing 6	3 ... 8 bar	Internal
R412012797	\varnothing 6	-0.9 ... 10 bar	External

Part No.	DC operating voltage	Voltage tolerance DC
R412012796	24 V	-10% / +10%
R412012797	24 V	-10% / +10%

1 = plug-in connection Ø 8 mm↔2 and 4 = plug-in connection Ø 6 mm or thread connections M7↔3 and 5 = plug-in connection Ø 10 mm↔R = collected pilot exhaust, plug-in connection Ø 6 mm↔X = external pilot, plug-in connection Ø 6 mm, connection X plugged with internal pilot control

Technical information

The min. control pressure must be adhered to, since otherwise faulty switching and valve failure may result!

The pressure dew point must be at least 15 °C under ambient and medium temperature and may not exceed 3 °C .

The oil content of compressed air must remain constant during the life cycle.

Use only the approved oils from AVENTICS. Further information can be found in the "Technical information" document (available in the MediaCentre).

Double base plate principle

Technical information

Material	
Base plate	Polyamide
push-in fitting	Brass, nickel-plated
Seal	Acrylonitrile butadiene rubber
Screws	Steel
Tie-rods	Aluminum

Blanking plate, Series HF04



Working pressure min./max.	-0.9 ... 10 bar
Ambient temperature min./max.	-5 ... 50 °C
Medium	Compressed air
Mounting screw	cross recessed DIN EN ISO 4757-Z0
Tightening torque for mounting screws	0.2 Nm
Weight	0.082 kg

Technical data

Part No.	Type	Delivery unit
1825700104	Blanking plate, incl. sealing kit, 2x mounting screws	1 piece

Technical information

The min. control pressure must be adhered to, since otherwise faulty switching and valve failure may result!
 The pressure dew point must be at least 15 °C under ambient and medium temperature and may not exceed 3 °C .
 The oil content of compressed air must remain constant during the life cycle.
 Use only the approved oils from AVENTICS. Further information can be found in the "Technical information" document (available in the MediaCentre).

Technical information

Material	
Base plate	Polyamide
Seal	Nitrile rubber

Dimensions

Dimensions

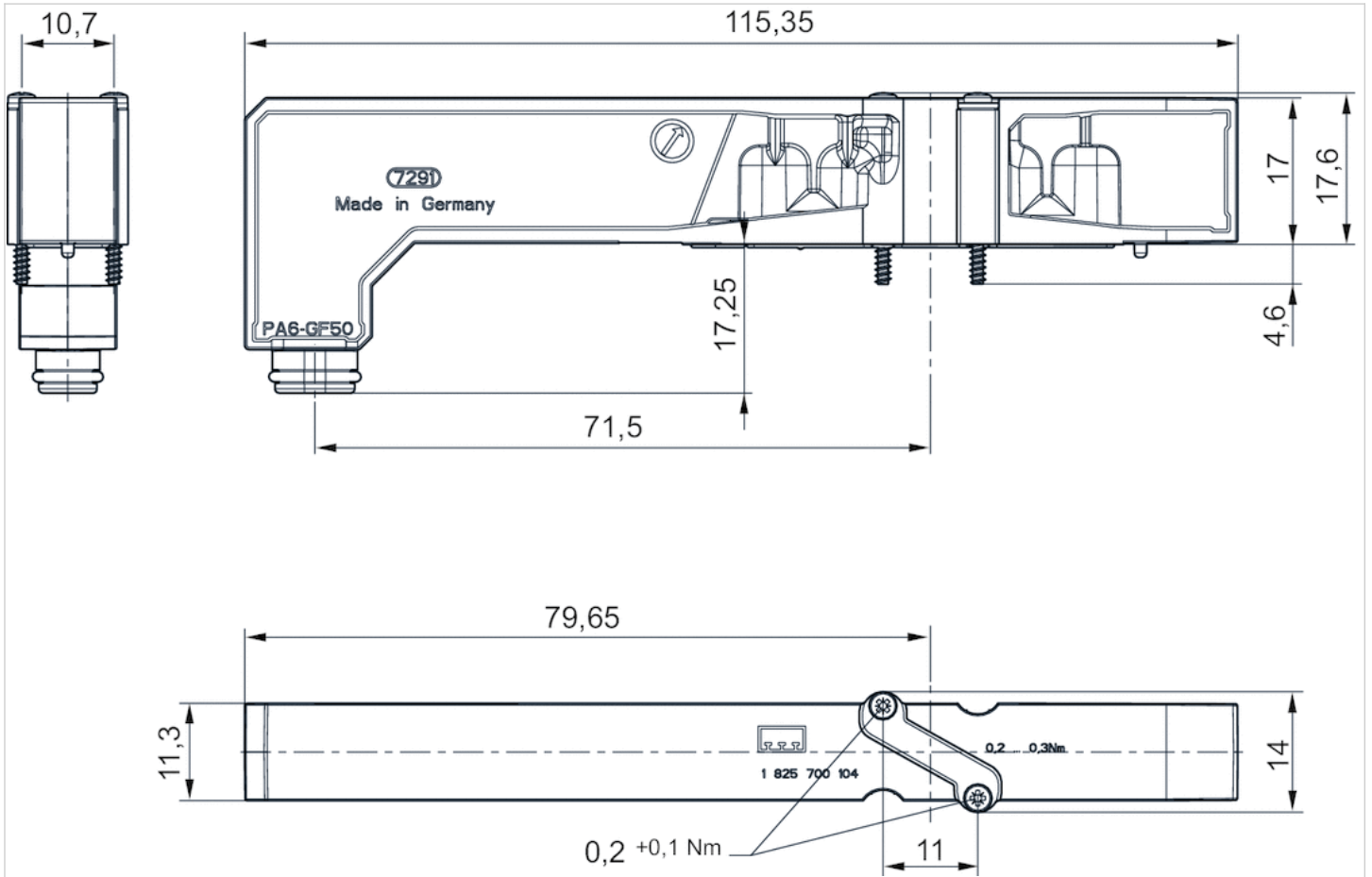

base plates

- for HF04

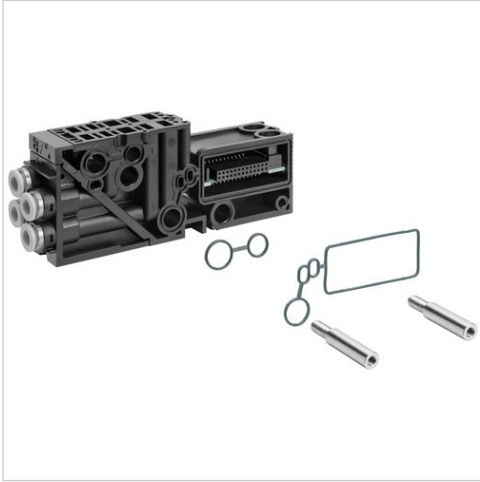

Weight

See table below

Technical data

Part No.	Type	Scope of delivery	Delivery unit
1827010708	HF04	"Base plate for 2 double solenoid valves, push-in fitting Ø6 mm, 2 tie rod extensions, and 1 sealing kit "	1 piece
R412004053	HF04	Base plate for 2 double solenoid valves, thread connection M7, 2 tie rod extensions, and 1 sealing kit	1 piece
R412006823	HF04	Base plate for 2 single solenoid valves, push-in fitting Ø6 mm, 2 tie rod extensions, and 1 sealing kit	1 piece
R412006824	HF04	Base plate for 2 single solenoid valves, M7 thread connection, 2 tie rod extensions, and 1 sealing kit	1 piece

Part No.	Weight
1827010708	0.126 kg
R412004053	0.13 kg
R412006823	0.122 kg
R412006824	0.13 kg

Technical information

The min. control pressure must be adhered to, since otherwise faulty switching and valve failure may result!

The pressure dew point must be at least 15 °C under ambient and medium temperature and may not exceed 3 °C .

The oil content of compressed air must remain constant during the life cycle.

Use only the approved oils from AVENTICS. Further information can be found in the "Technical information" document (available in the MediaCentre).

QR1-S-RBS standard series

- Blanking plug
- pin bushing
- Ø 6 Ø 8 Ø 10
- QR1-S-RBS



Working pressure min./max.

-0.95 ... 10 bar

Ambient temperature min./max.

0 ... 60 °C

Weight per piece

See table below

Technical data

Part No.	Port G	Delivery unit	Weight per piece
2123206000	Ø 6	20 piece	0.001 kg
2123208000	Ø 8	20 piece	0.001 kg
2123210000	Ø 10	20 piece	0.002 kg

Technical information

The series QR1 (plastic) and QR2 (metal) can not be combined

For further information about assembling and tolerances of adaptable tubing can be found in the "Technical information" document (available in the MediaCentre).

Technical information

Material	
Material	nickel-plated
Housing	Polybutyleneterephthalate

Dimensions

Dimensions

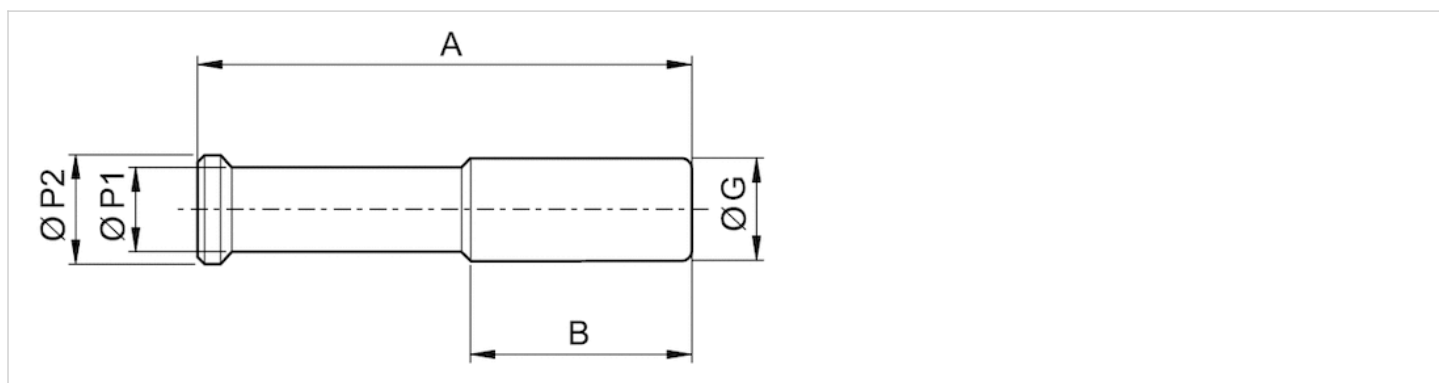

Dimensions

Part No.	Port G	A	B	Ø P1	Ø P2
2123206000	Ø 6	32	17	4	6
2123208000	Ø 8	39	21,5	5	9
2123210000	Ø 10	42	21	8	10

Separator

- for HF04



Weight

See table below

Technical data

Part No.	Type	Delivery unit	Weight
R412003402	Separators between two double subbases, channel 1	10 piece	0.025 kg
R412000998	Separators: between two double subbases, channels 3 and 5	10 piece	0.017 kg
R412003404	Separators: between two valve positions, channels 1, 3 and 5	-	0.029 kg

Multipole plug, series CON-MP

- open cable ends 25-pin
- with cable
- unshielded



Ambient temperature min./max.	-20 ... 80 °C
Operational voltage	24 V DC
Protection class	IP67
Wire cross-section	0.22 mm ²
Weight	See table below

Technical data

Part No.	Electrical connection	Max. current	Number of wires	Cable sheath
	1			
R419500454	Socket D-Sub 25-pin straight 180°	3 A	25	Polyvinyl chloride
R419500455	Socket D-Sub 25-pin straight 180°	3 A	25	Polyvinyl chloride
R419500456	Socket D-Sub 25-pin straight 180°	3 A	25	Polyvinyl chloride
R412022156	Socket D-Sub 25-pin straight 180°	3 A	25	Polyvinyl chloride
R419500457	Socket D-Sub 25-pin straight 180°	3 A	25	Polyurethane
R419500458	Socket D-Sub 25-pin straight 180°	3 A	25	Polyurethane
R419500459	Socket D-Sub 25-pin straight 180°	3 A	25	Polyurethane
R419500460	Socket D-Sub 25-pin angled 90°	3 A	25	Polyvinyl chloride
R419500461	Socket D-Sub 25-pin angled 90°	3 A	25	Polyvinyl chloride
R419500462	Socket D-Sub 25-pin angled 90°	3 A	25	Polyvinyl chloride
R412022352	Socket D-Sub 25-pin angled 90°	3 A	25	Polyvinyl chloride
R419500463	Socket D-Sub 25-pin angled 90°	3 A	25	Polyurethane
R419500464	Socket D-Sub 25-pin angled 90°	3 A	25	Polyurethane
R419500465	Socket D-Sub 25-pin angled 90°	3 A	25	Polyurethane

Part No.	Bending radius min.	Cable-Ø	Cable length	Weight		Fig.
R419500454	-	8.5 mm	3 m	0.465 kg	-	Fig. 1
R419500455	-	8.5 mm	5 m	0.731 kg	-	Fig. 1
R419500456	-	8.5 mm	10 m	1.373 kg	-	Fig. 1
R412022156	-	8.5 mm	15 m	2.002 kg	-	Fig. 1
R419500457	78.75 mm	10.5 mm	3 m	0.51 kg	1)	Fig. 1
R419500458	78.75 mm	10.5 mm	5 m	0.789 kg	1)	Fig. 1
R419500459	78.75 mm	10.5 mm	10 m	1.491 kg	1)	Fig. 1
R419500460	-	8.5 mm	3 m	0.46 kg	-	Fig. 2
R419500461	-	8.5 mm	5 m	0.707 kg	-	Fig. 2
R419500462	-	8.5 mm	10 m	1.334 kg	-	Fig. 2
R412022352	-	8.5 mm	15 m	1.982 kg	-	Fig. 2

Part No.	Bending radius min.	Cable-Ø	Cable length	Weight		Fig.
R419500463	78.75 mm	10.5 mm	3 m	0.484 kg	1)	Fig. 2
R419500464	78.75 mm	10.5 mm	5 m	0.767 kg	1)	Fig. 2
R419500465	78.75 mm	10.5 mm	10 m	1.461 kg	1)	Fig. 2

1) suitable for dynamic laying

Technical information

The specified protection class is only valid in assembled and tested state.
The increased wire cross-section of pin 25 is 0.82 mm².

Technical information

Material

Housing	Thermoplastic elastomer
Cable sheath	Polyvinyl chloride Polyurethane

Dimensions

Fig. 1

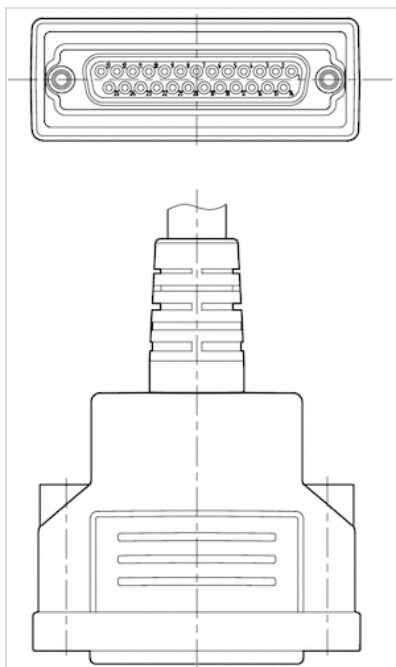
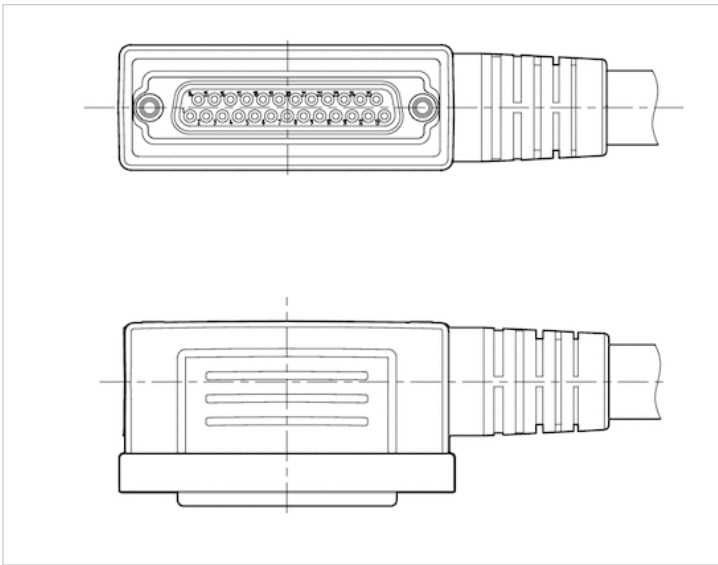
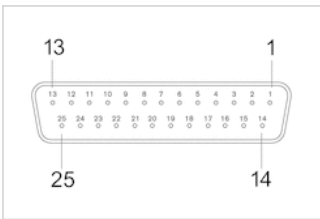

Fig. 2



Pin assignments

PIN assignment and cable colors, cable identification as per DIN 47100



Socket

Pin	1	2	3	4	5	6	7	8	9
Color	white	brown	green	yellow	gray	pink	blue	red	black
10	11	12	13	14	15				
violet	gray/pink	red/blue	white/green	brown/green	white/yellow				
16	17	18	19	20	21				
yellow/brown	white/gray	gray/brown	white/pink	pink/brown	white/blue				
22	23	24	25						
brown/blue	white/red	brown/red	white/black						

Distributor, Series AES

- 4x passive distributor, M12x1, 8-pin / 4x M8x1, 3-pin

- Plug (male), M12x1, 8-pin



Ambient temperature min./max.	-30 ... 80 °C
Operational voltage electronics	24 V DC
Power consumption electronics	2 A
Protection class	IP67
Weight	0.07 kg

Technical data

Part No.	Type	Port	
		1	2
R402001810	16DI4M12 16DI8M8	Plug (male), M12x1, 8-pin	Socket (female), M8x1, 3-pin

Technical information

Material	
Housing	Polyamide

Dimensions

Dimensions

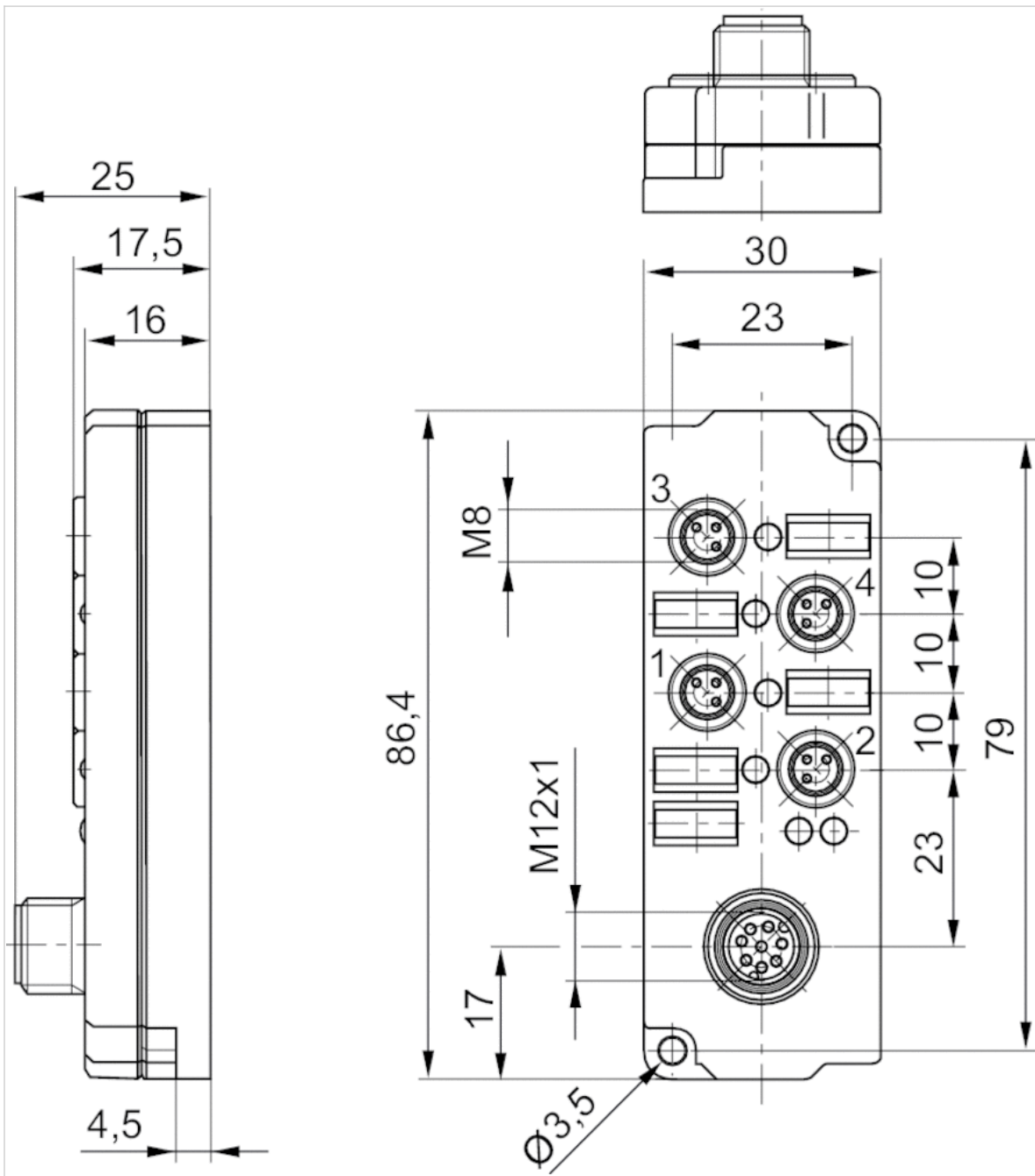

Plug box



Weight

0.12 kg

Technical data

Part No.	Type
1827030206	Plug box, 25-pin, complete
R412013379	HD multipole plug box, 44-pin, complete

Further accessories: For valve plug connectors, contact bridges, plugs and cables, etc., see the Chapter "Electrical connection technologies". For connectors, plastic tubing, etc., see the Chapter "Pneumatic connection technologies". Fieldbus connections can be found in the correspondent chapter.

Mounting for DIN rail

- For bus coupler



Weight

0.052 kg

Technical data

Part No.	Type
1827010709	Mounting kit for hat rail DIN EN 60715, 35x15

Scope of delivery: (1) 2 clamp mountings, (2) 2 screws M6x65, (3) 1 screw M6x8

Dimensions

Dimensions

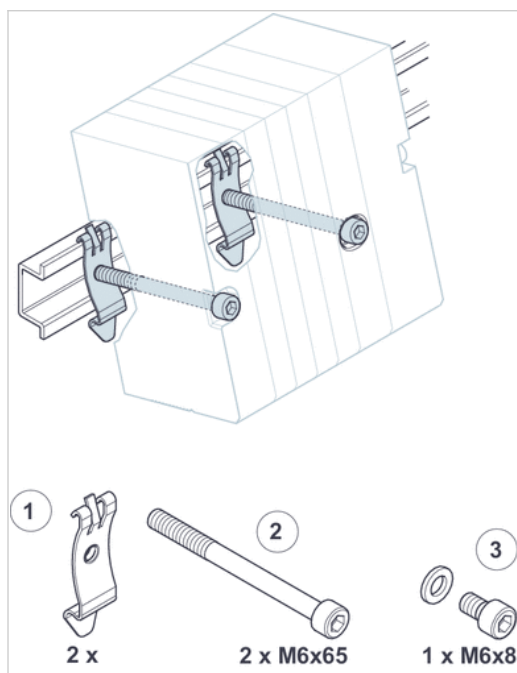

Scope of delivery: (1) 2 clamp mountings, (2) 2 screws M6x65, (3) 1 screw M6x8

Efficient pneumatic solutions, our program: cylinders and drives, valves and valve systems, air supply management

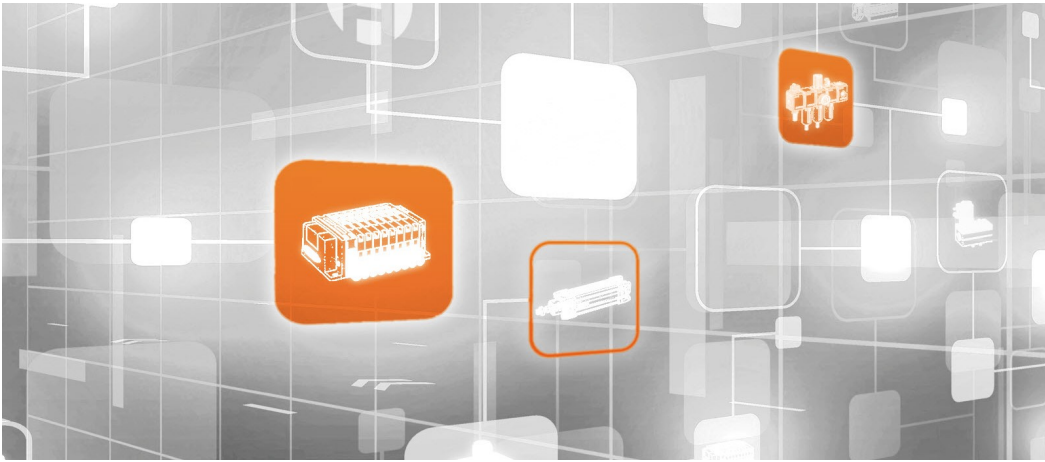

Visit us: [Emerson.com/Aventics](https://www.emerson.com/Aventics)

Your local contact: [Emerson.com/contactus](https://www.emerson.com/contactus)



[Emerson.com](https://www.emerson.com)



[Facebook.com/EmersonAutomationSolutions](https://www.facebook.com/EmersonAutomationSolutions)



[LinkedIn.com/company/Emerson-Automation-Solutions](https://www.linkedin.com/company/Emerson-Automation-Solutions)



[Twitter.com/EMR_Automation](https://twitter.com/EMR_Automation)

An example configuration is depicted on the title page. The delivered product may thus vary from that in the illustration. Subject to change. This Document, as well as the data, specifications and other information set forth in it, are the exclusive property of AVENTICS GmbH. It may not be reproduced or given to third parties without its consent. Only use the AVENTICS products shown in industrial applications. Read the product documentation completely and carefully before using the product. Observe the applicable regulations and laws of the respective country. When integrating the product into applications, note the system manufacturer's specifications for safe use of the product. The data specified only serve to describe the product. No statements concerning a certain condition or suitability for a certain application can be derived from our information. The information given does not release the user from the obligation of own judgment and verification. It must be remembered that the products are subject to a natural process of wear and aging.

The Emerson logo is a trademark and service mark of Emerson Electric Co. Brand logotype are registered trademarks of one of the Emerson family of companies. All other marks are the property of their respective owners. © 2017 Emerson Electric Co. All rights reserved.
2022-09-30



CONSIDER IT SOLVED™