

Configuration Data Sheet

October 2023
00806-0100-4435, Rev AD

9935 Level Bypass Chamber

Rosemount™ 9935 Level Bypass Chamber Configuration Data Sheet

★ Default Select only one of the items provided One or more of the listed items can be

General information	
Company: _____	Phone No.: _____ Date: _____
Contact name: _____	RFQ No.: _____
Email: _____	Tag: _____

Process conditions				
Pressure	Min: _____	Oper: _____	Max: _____	Units of measurement: _____
Temperature	Min: _____	Oper: _____	Max: _____	Units of measurement: _____
Description of media _____				
Is the chamber for interface measurement?	<input type="radio"/> Yes	<input type="radio"/> No	Note Consider three or more process connections for interface applications.	
Is this a saturated steam application?	<input type="radio"/> Yes	<input type="radio"/> No		

Customer-specific design criteria
Are there any existing specifications, including minimum pipe schedule, general piping specifications, or an approved manufacturer list (AML/AVL) to which these chambers must comply? <input type="radio"/> Yes (please provide) <input type="radio"/> No

Material of construction	Process connection type	Connection bore
<input type="radio"/> Carbon steel A106B SMLS A105 <input type="radio"/> Stainless steel 316/316L <input type="radio"/> Other: _____	<input type="radio"/> RFSO <input type="radio"/> RTJWN <input type="radio"/> Socket weld fitting <input type="radio"/> RFWN <input type="radio"/> NPTM <input type="radio"/> Plain end nipple fitting <input type="radio"/> RFSW <input type="radio"/> NPTF <input type="radio"/> Other: _____	<input type="radio"/> Full bore <input type="radio"/> 1/2-in.

Process rating	Process connection size
<input type="radio"/> Class 150 <input type="radio"/> Class 300 <input type="radio"/> Class 600 <input type="radio"/> Class 900 <input type="radio"/> Class 1500 <input type="radio"/> Other: _____	<input type="radio"/> 1/2-in. <input type="radio"/> 3/4-in. <input type="radio"/> 1-in. <input type="radio"/> 1 1/2-in. <input type="radio"/> 2-in. <input type="radio"/> Other: _____

Mounting style	Flanged instrument connection
	<input type="radio"/> 2-in. <input type="radio"/> 3-in. <input type="radio"/> 4-in. <input type="radio"/> Raised face (RF) <input type="radio"/> Ring joint (RTJ)
	<input type="radio"/> Class 150 <input type="radio"/> Class 300 <input type="radio"/> Class 600 <input type="radio"/> Class 900 <input type="radio"/> Class 1500 <input type="radio"/> Class 2500 <input type="radio"/> Other: _____

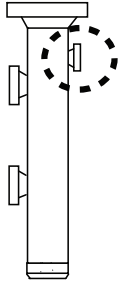
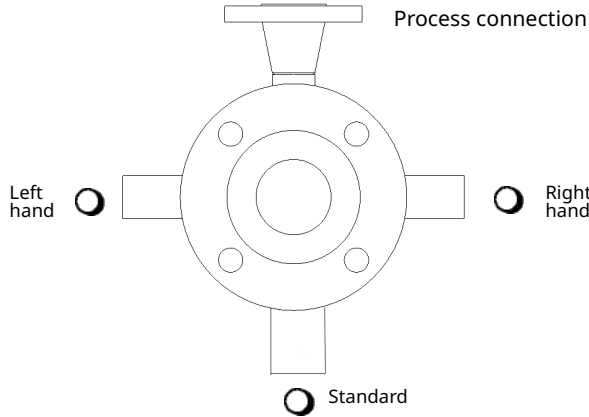
<p>Vent</p> 	<p>Type</p> <p><input type="radio"/> NPT</p> <p><input type="radio"/> Flange</p> <p><input type="radio"/> SW</p> <p><input type="radio"/> Other: _____</p> <p>Size</p> <p><input type="radio"/> 1/2-in.</p> <p><input type="radio"/> 3/4-in.</p> <p><input type="radio"/> 1-in.</p>	<p><input type="checkbox"/> Vent valve (optional)</p> <p>Type</p> <p><input type="radio"/> Ball</p> <p><input type="radio"/> Gate</p> <p><input type="radio"/> Other _____</p> <p>Material</p> <p><input type="radio"/> Carbon steel</p> <p><input type="radio"/> Stainless steel</p> <p>Valve notes: _____</p>	<p>Vent (top view)</p> 
--	---	--	--

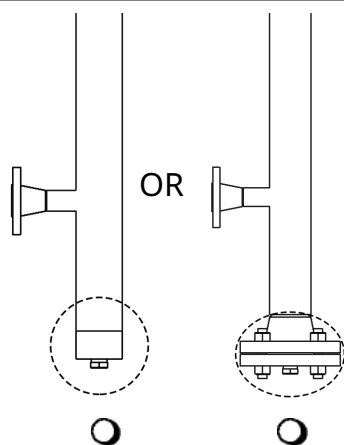
<p>Drain</p> 	<p>Type</p> <p><input type="radio"/> NPT</p> <p><input type="radio"/> Flange</p> <p><input type="radio"/> SW</p> <p><input type="radio"/> Other: _____</p> <p>Size</p> <p><input type="radio"/> 1/2-in.</p> <p><input type="radio"/> 3/4-in.</p> <p><input type="radio"/> 1-in.</p>	<p><input type="checkbox"/> Drain valve (optional)</p> <p>Type</p> <p><input type="radio"/> Ball</p> <p><input type="radio"/> Gate</p> <p><input type="radio"/> Other _____</p> <p>Material</p> <p><input type="radio"/> Carbon steel</p> <p><input type="radio"/> Stainless steel</p> <p>Valve notes: _____</p>	<p>Test and inspections</p> <p><input type="checkbox"/> Hydrostatic test</p> <p><input type="checkbox"/> PMI</p> <p><input type="checkbox"/> X-Ray</p> <p><input type="checkbox"/> Magparticle/Dye pen</p> <p><input type="radio"/> NACE® MR0103</p> <p><input type="radio"/> NACE MR0175</p>
--	---	---	--

Documentation	
<p><input type="checkbox"/> Material Traceability Report (MTR)</p> <p><input type="checkbox"/> Drawings</p> <p style="margin-left: 20px;"><input type="checkbox"/> Approval <input type="checkbox"/> As-built</p>	<p><input type="checkbox"/> Country of origin</p> <p><input type="checkbox"/> Certificate of conformance</p> <p><input type="checkbox"/> CRN: Specify province: _____</p>

Other special request (describe or provide sketch)

For more information: [Emerson.com](https://www.emerson.com)

© 2023 Emerson. All rights reserved.

Emerson Terms and Conditions of Sale are available upon request.
The Emerson logo is a trademark and service mark of Emerson Electric Co.
Rosemount is a mark of one of the Emerson family of companies.
All other marks are the property of their respective owners.