

# Linear feeder

## HLF07-M - HLF50-M

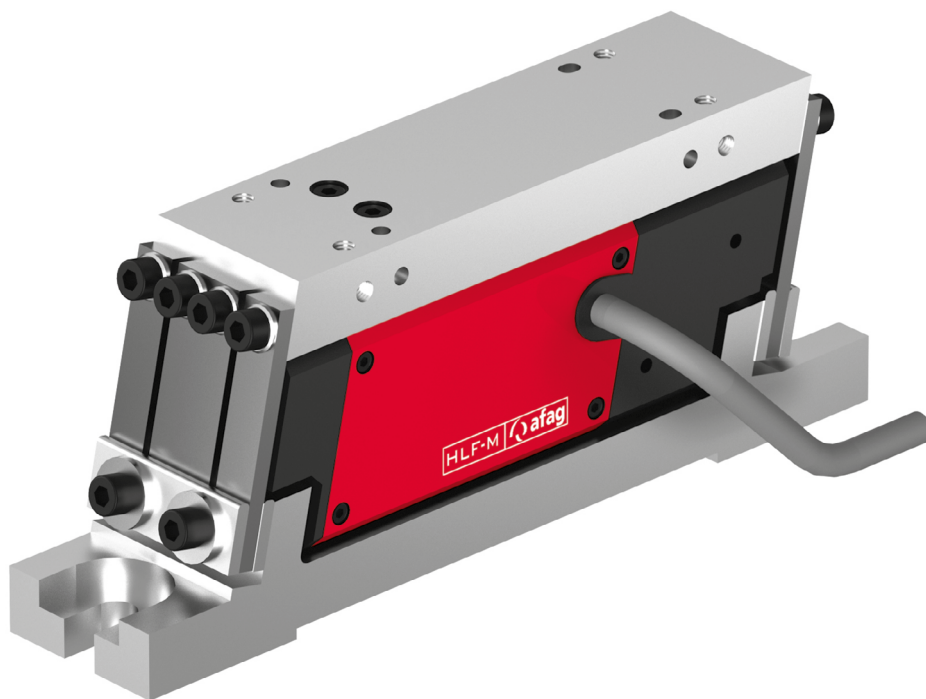

- Optimized vibrating force compensation and therefore no mutual interference of several combined devices
- Low vibration amplitudes and therefore very small gap dimensions
- Compact design with large mounting surface through innovative construction

### Overview

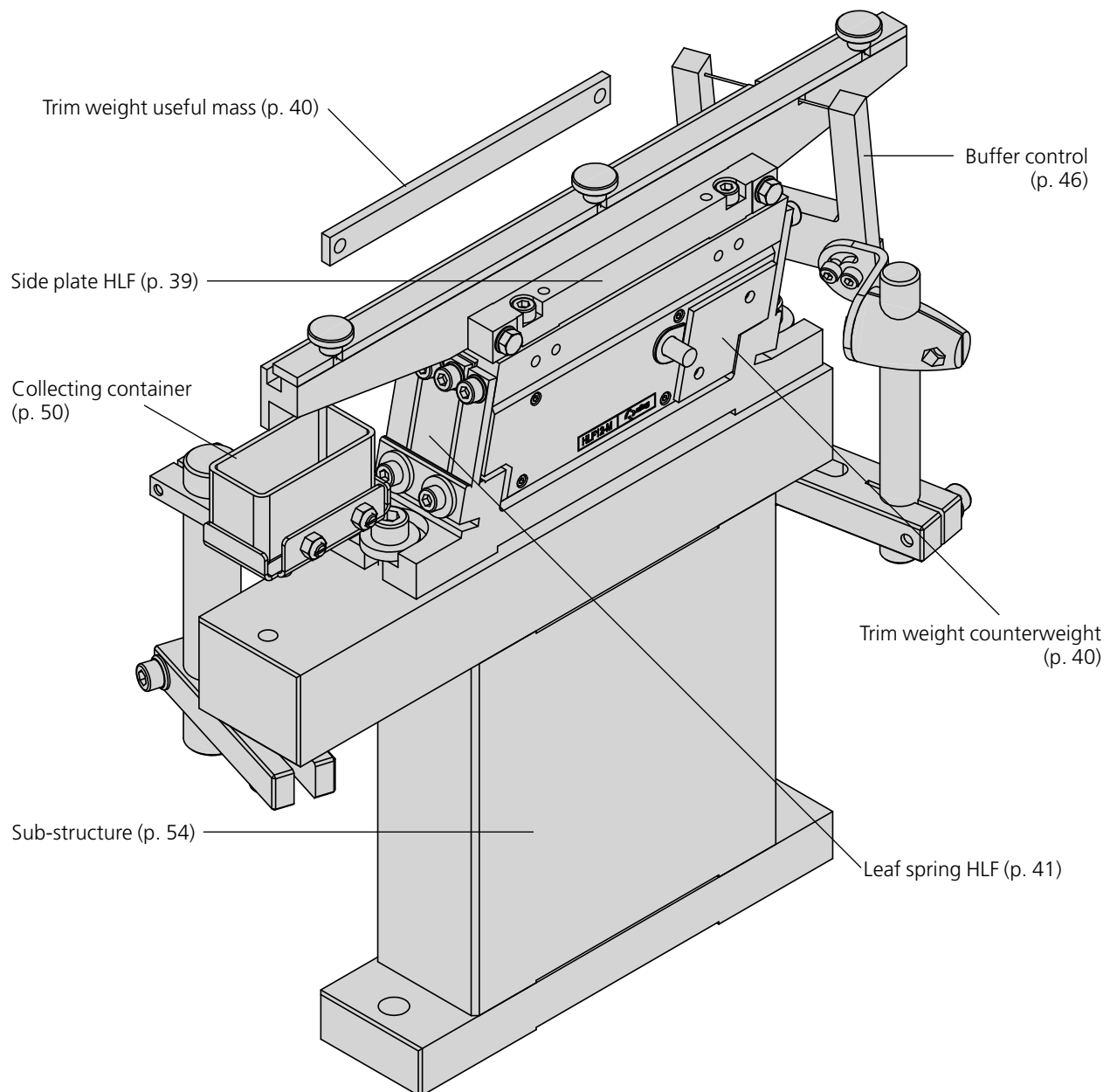

For fastening the rail to the HLF two variants are possible:

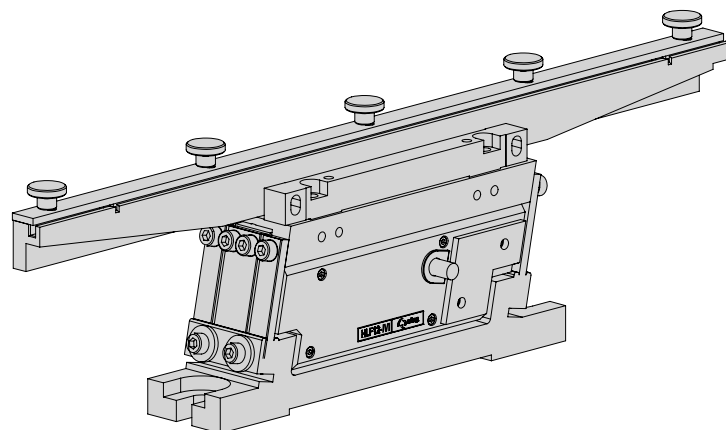

**Variant 1** Construction with side plate O

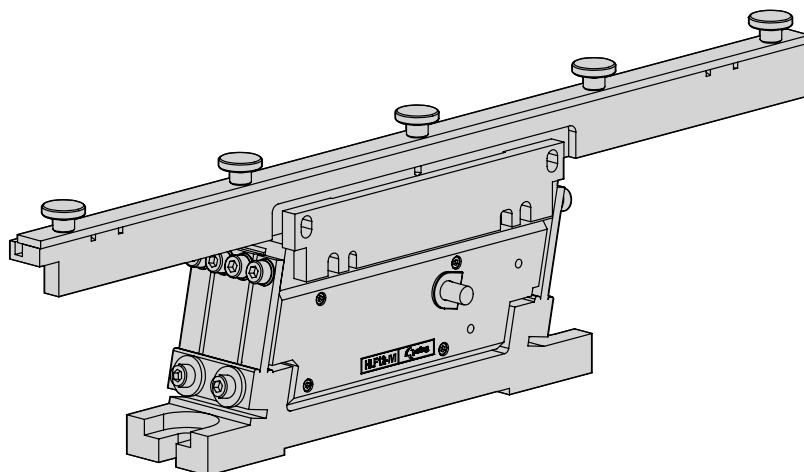

**Variant 2** Construction with side plate S

# Dimensions and dimension drawings

**HLF-M**

Type	HLF07-M	HLF12-M	HLF25-M	HLF50-M
A	300 mm	400 mm	500 mm	700 mm
B	25 mm	30 mm	38 mm	44 mm
C	10 mm	10 mm	10 mm	10 mm
D1	7 mm	9 mm	9 mm	11 mm
D2	4 x M5	4 x M5	4 x M6	4 x M6
D3	2 x 4 H7	2 x 4 H7	2 x 5 H7	2 x 5 H7
E	36 mm	42 mm	50 mm	60 mm
F	73 mm	80 mm	108 mm	140 mm
G	80 mm	100 mm	120 mm	190 mm
H	50 mm	59 mm	86 mm	96 mm
K	60 mm	80 mm	100 mm	170 mm
M	170 mm	200 mm	260 mm	350 mm
N	2 x 4 mm	2 x 4 mm	2 x 5 mm	2 x 5 mm
P	150 mm	180 mm	240 mm	320 mm
X	85 ± 10 mm	105 ± 10 mm	135 ± 20 mm	180 ± 10 mm
Y	0 ± 9 mm	0 ± 10 mm	0 ± 12 mm	0 ± 12 mm
Z	77 ± 8,5 mm	84 ± 11 mm	110 ± 15 mm	155 ± 15 mm

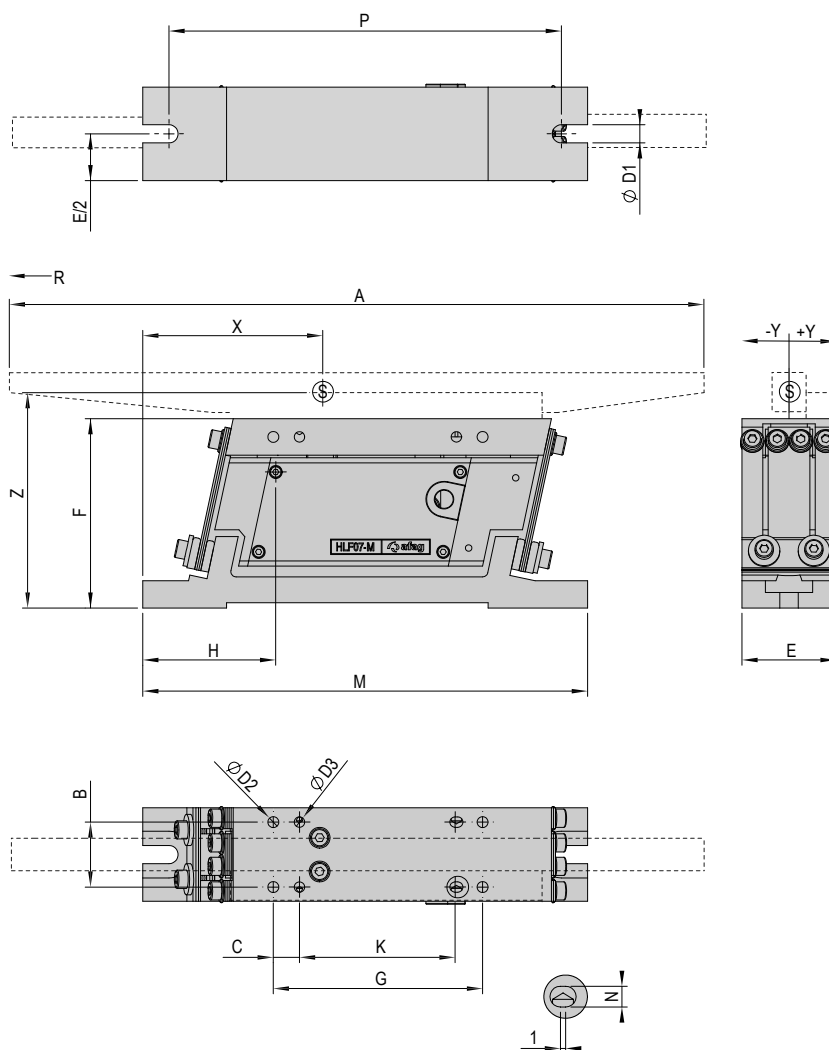

R = Feeding direction  
S = Track center of gravity

HLF-M	
Operating temperature	10 - 45 °C

Type	HLF07-M	HLF07-M	HLF12-M	HLF12-M
<b>Order number</b>	<b>50260370</b>	<b>50270718</b>	<b>50259924</b>	<b>50270770</b>
Mechanical vibration frequency	100 Hz	120 Hz	100 Hz	120 Hz
Mains connection (mains voltage/mains frequency)	230 V/50 Hz	115 V/60 Hz	230 V/50 Hz	115 V/60 Hz
Max. power consumption	15 VA	15 VA	19 VA	19 VA
Net weight	1.8 kg	1.8 kg	2.8 kg	2.8 kg
Feed rail weight (ideal)	0.7 ± 0.1 kg	0.7 ± 0.1 kg	1.2 ± 0.1 kg	1.2 ± 0.1 kg
Max. feeder speed	7 m/min	7 m/min	7 m/min	7 m/min
Reactive force compensation	•	•	•	•
Protection type	IP 54	IP 54	IP 54	IP 54

Type	HLF25-M	HLF25-M	HLF50-M	HLF50-M
<b>Order number</b>	<b>50259276</b>	<b>50270897</b>	<b>50421880</b>	<b>50431259</b>
Mechanical vibration frequency	100 Hz	120 Hz	100 Hz	120 Hz
Mains connection (mains voltage/mains frequency)	230 V/50 Hz	115 V/60 Hz	230 V/50 Hz	115 V/60 Hz
Max. power consumption	100 VA	100 VA	170 VA	170 VA
Net weight	6 kg	6 kg	12.5 kg	12.5 kg
Feed rail weight (ideal)	2.5 ± 0.1 kg	2.5 ± 0.1 kg	5 ± 0.1 kg	5 ± 0.1 kg
Max. feeder speed	7 m/min	7 m/min	7 m/min	7 m/min
Reactive force compensation	•	•	•	•
Protection type	IP 54	IP 54	IP 54	IP 54

Note: • = existent  
Track not included in scope of supply.

### Included in delivery

- 2x Leaf spring HLF