

Type 289P Pilot-Operated Relief Valve



W3167-2

Figure 1. 2 NPT Type 289P Pilot-Operated Relief Valve



W6834

Figure 2. 1 NPT Type 289P Pilot-Operated Relief Valve

Introduction

The Type 289P is an accurate, low-cost, pilot-operated relief valve. This relief valve is suitable for service on natural gas, air, propane, and other operating media compatible with the internal parts. The external control line provides quick, accurate pressure registration. Pilot operation requires very little buildup over set pressure to completely open the main valve for maximum relief capacity.

Features

- **Economical**—Simple, low-cost design with the accuracy and capacity of higher-priced relief valves.
- **High Relief Capacity with Low Buildup**—High-flow rates result from small inlet pressure increases and provide high capacity per investment dollar.
- **Accurate**—Very little relief pressure buildup is required to completely open the main valve due to pilot operation and light-rate main valve spring.
- **Fast Reseat After Operation**—The fixed restriction in the pilot allows the valve plug to quickly reseal after operation.
- **Ease of Maintenance**—No special tools are required to perform maintenance. All maintenance can be performed with the relief valve in the line.
- **Rugged Construction**—Engineered for longer service life with minimal maintenance requirements.
- **Powder Paint Coating**—Fisher® products are powder paint coated, offering impact, abrasion, and corrosion resistance.
- **Corrosion Resistant Fasteners**—Adjusting screw and bolting are double zinc-chromated for enhanced corrosion resistance.
- **Full Usable Capacity**—Fisher regulators are laboratory tested. 100 percent of the published capacities can be used with confidence.



Specifications

Body Size and End Connection Style

1 or 2 NPT

Maximum Relief (Inlet) Pressure⁽¹⁾⁽²⁾

1 NPT: 50 psig / 3.4 bar over relief set pressure or 110 psig / 7.6 bar whichever is lower
2 NPT: 15 psig / 1.0 bar

Relief Set Pressure Ranges

See Table 1

Pilot Information

See Tables 2 and 3

Flow Capacities

See Capacity Information section and Tables 2 and 3

Wide-Open Flow Coefficients

See Table 4

Pressure Registration

External

Pilot Control Line and Vent Connections

1/4 NPT

Relief Valve Temperature Capabilities⁽²⁾

With Nitrile (NBR): -20° to 180°F / -29° to 82°C
With Fluorocarbon (FKM):
0° to 300°F / -18° to 149°C

Approximate Weights

1 NPT: 5 pounds / 2.3 kg
2 NPT: 15 pounds / 6.8 kg

Construction Materials

1 NPT Type 289P Main Valve

Body and Spring Case: Aluminum
Diaphragm: Nitrile (NBR) (**standard**) or Fluorocarbon (FKM) (optional)
O-Rings: Nitrile (NBR) (**standard**) or Fluorocarbon (FKM) (high temperature)
O-Ring Holder and Washer: Aluminum
Pilot Tube: Aluminum
Spring: Zinc plated-steel
Stem: Stainless steel
Stem Guide Assembly: Brass with stainless steel bushing (**standard**) and zinc with brass bushing
Diaphragm Plate: Zinc-plated steel

1 NPT Type 289P Main Valve (continued)

Outlet Screen Gasket: Neoprene (CR) or composite
Stem Gasket: Composite
Removable Outlet Screen: Monel®
Spring Loading Screw Gaskets: Copper or composite
Spacer: Brass (**standard**) and stainless steel

2 NPT Type 289P Main Valve

Body: Cast Iron
Spring Case: Aluminum
Diaphragm: Nitrile (NBR)
Upper and Lower Diaphragm Plates: Plated-steel
Stem Guide Assembly: Cast iron with brass bushing
Orifice: Brass
Spacer: Brass
O-Ring: Nitrile (NBR)
O-Ring Washer: Stainless steel
Stem: Brass
Spring: Zinc-plated steel
Spring Seat: Zinc-plated steel
Stem Gasket: Composite
Closing Cap: Zinc

Type 6358B Pilot

Body and Spring Case: Aluminum
Valve Plug and Stem: Nitrile (NBR) (**standard**) or Fluorocarbon (FKM) (high temperature) plug and stainless steel stem
Diaphragm: Nitrile (NBR) (**standard**) or Fluorocarbon (FKM) (high temperature)
Stem Guide: Stainless steel
O-Rings and Gaskets: Nitrile (NBR) (**standard**) or Fluorocarbon (FKM) (high temperature)
Valve Spring: Stainless steel
Pilot Spring: Steel
Body Plug: S30300 Stainless steel

Type 6365 Pilot

Body and Spring Case: Aluminum
Valve Plug and Stem: Polyethylene
Diaphragm: Nitrile (NBR)
Stem Guide: Stainless steel
Gaskets: Composite
Valve Spring: Stainless steel
Pilot Spring: Steel

1. Relief pressure plus maximum allowable buildup over setting.

2. The pressure/temperature limits in this Bulletin and any applicable standard or code limitation should not be exceeded.

Monel® is a mark owned by Special Metals Corporation.

Table 1. Relief Set Pressure Ranges and Pilot Control Spring Information

MAIN VALVE BODY SIZE	PILOT TYPE	RELIEF SET PRESSURE RANGE		PILOT CONTROL SPRING INFORMATION					
		psig	bar	Part Number	Color	Wire Diameter		Free Length	
						Inches	mm	Inches	mm
1 NPT	6358B	10 to 18 psig	0.69 to 1.2 bar	1B986027212	Green Unpainted Red	0.120	3.05	2.125	54.0
		18 to 30 psig	1.2 to 2.1 bar	1B788327022		0.142	3.61	2.125	54.0
		30 to 100 psig	2.1 to 7.0 bar	1K748527202		0.187	4.75	2.125	54.0
2 NPT	6365	14-inches w.c. to 2 psig	35 mbar to 0.14 bar	14A9672X012	Yellow	0.070	1.78	2.125	54.0
	6358B	2 to 10 psig	0.14 to 0.69 bar	14A9673X012	Black	0.102	2.59	2.125	54.0

Table 2. 1 NPT Main Valve Capacities and Type 6358B Pilot Information

MAIN VALVES PRING, PART NUMBER, AND COLOR	SET PRESSURE RANGE		SET PRESSURE ⁽¹⁾		BUILDUP OVER SET PRESSURE TO BEGIN OPENING MAIN VALVE ⁽²⁾		BUILDUP OVER SET PRESSURE TO FULLY OPEN MAIN VALVE ⁽³⁾		PRESSURE DROP BELOW SET PRESSURE TO RESEAT PILOT		CAPACITIES OF 0.6 SPECIFIC GRAVITY NATURAL GAS ⁽⁴⁾	
	psig	bar	psig	bar	psig	bar	psig	bar	psig	bar	SCFH	Nm ³ /h
	For set pressures up to 30 psig / 2.1 bar 1F826927052 Pink	10 to 18	0.69 to 1.2	10	0.69	0.8	0.055	1.0	0.07	1.0	0.07	23,000
15				1.0	29,000							777
18				1.2	32,000							858
18 to 30		1.2 to 2.1	18	1.2	0.9	0.062	1.2	0.08	1.0	0.07	32,000	858
	25		1.7	39,000							1,045	
	30		2.1	44,000							1,179	
For set pressures over 30 psig / 2.1 bar 1D892327022 Red	30 to 100	2.1 to 7.0	30	2.1	1.4	0.10	1.9	0.13	1.0	0.07	44,000	1,179
			40	2.8							54,000	1,447
			50	3.4							64,000	1,715
			60	4.1							73,000	1,956
			70	4.8	1.6	0.11	2.1	0.14	1.0	0.07	83,000	2,224
			80	5.5							92,000	2,466
			90	6.2							102,000	2,734
100	7.0	111,000	2,975									

1. Set pressure is defined as the pressure at which the pilot exhaust starts to bubble (discharge).
2. Crack pressure is the inlet pressure at which the main valve starts audible flow.
3. Inlet pressure buildup over the set pressure to achieve wide-open capacity.
4. Capacities with inlet piping equal to body size and without outlet piping.

Table 3. 2 NPT Main Valve Capacities and Types 6365 and 6358B Pilot Information

PILOT TYPE	RELIEF SET PRESSURE RANGE, SPRING PART NUMBER, AND COLOR	SET PRESSURE ⁽¹⁾		BUILDUP OVER SET PRESSURE TO FULLY OPEN MAIN VALVE ⁽²⁾		PRESSURE DROP BELOW SET PRESSURE TO RESEAT PILOT		CAPACITIES OF 0.6 SPECIFIC GRAVITY NATURAL GAS ⁽³⁾	
		psig	bar	psig	mbar	psig	mbar	SCFH	Nm ³ /h
6365	14-inches w.c. to 2 psig / 35 mbar to 0.14 bar 14A9672X012 Yellow	0.5	0.03	0.25	17	0.25	17	18,700	501
		1.0	0.07					24,000	643
		1.5	0.10					28,400	761
		2.0	0.14					32,100	860
6358B	2 to 10 psig / 0.14 to 0.69 bar 14A9673X012 Black	2.0	0.14	0.30	21	0.30	21	32,500	871
		4.0	0.28					44,300	1,187
		6.0	0.41					53,700	1,439
		8.0	0.55					62,000	1,662
		10.0	0.69					69,500	1,863

1. Set pressure is defined as the pressure at which the pilot exhaust starts to bubble (discharge).
2. Inlet pressure buildup over the set pressure to achieve wide-open capacity.
3. Capacities with inlet piping equal to body size and without outlet piping.

Principle of Operation

A pressure relief valve is a throttling pressure control device that opens and closes to ensure the downstream pressure does not rise above a predetermined pressure. **The Type 289P relief valve cannot be used as ASME safety relief valves.**

Inlet pressure registers on the underside of the main valve diaphragm and underside of the pilot diaphragm. As long as the inlet pressure is below the set pressure, the pilot control spring keeps the pilot valve plug closed. Inlet pressure passes through the pilot restriction and registers as loading pressure on top of the main valve diaphragm, keeping it closed.

When inlet pressure rises above the set pressure, the pressure on the pilot diaphragm overcomes the pilot control spring and opens the pilot valve plug. The pilot exhausts the loading pressure from the top of the main valve diaphragm and plug assembly. While inlet pressure is above the set pressure, the pilot continuously exhausts gas. Inlet pressure unbalance overcomes the main spring force and opens the main valve.

As the inlet pressure drops, the pilot control spring begins to close the pilot valve plug and the exhaust slows. This causes the inlet pressure to build in the main valve diaphragm casing, allowing the control spring to close the main valve. Once the main valve is closed, the pilot valve plug closes and the exhaust stops.

Installation

This relief valve may be installed in any position but must be oriented so that gas discharge from the main valve outlet and pilot vent does not create a fire hazard or explosion hazard. The main valve outlet, pilot vent, and pilot spring case vent must be protected against the entrance of water or other foreign material that may plug the openings or affect relief valve operation. Remote vent piping and rain cap may be required.

Flow must be into the connection marked "inlet" on the main valve body. An upstream control line is required for operation of this relief valve.

Capacity Information

Tables 2 and 3 show the natural gas relief capacities of the Type 289P relief valve at selected inlet pressures and outlet pressure settings. Flows are

in SCFH (at 60°F and 14.7 psia) and Nm³/h (at 0°C and 1.01325 bar) of 0.6 specific gravity natural gas. To determine equivalent capacities for air, propane, butane, or nitrogen, multiply the capacity by the following appropriate conversion factor: 0.775 for air, 0.628 for propane, 0.548 for butane, or 0.789 for nitrogen. For gases of other specific gravities, multiply the given capacity by 0.775, and divide by the square root of the appropriate specific gravity.

To find approximate relief capacities at set pressures or build-ups not given in Tables 2 and 3 use one of the following formulas and, if necessary, convert according to the factors in the paragraph above. Then, if capacity is desired in normal cubic meters per hour at 0°C and 1.01325 bar, multiply SCFH by 0.0268.

1. For critical pressure drops (absolute outlet pressure equal to or less than one-half of absolute inlet pressure), use the following formula:

$$Q = (P_1 + \text{Buildup})_{\text{abs}} C_g \sqrt{\frac{520}{GT}}$$

2. For pressure drops lower than critical (absolute outlet pressure greater than one-half of absolute inlet pressure), use the following formula:

$$Q = \sqrt{\frac{520}{GT}} C_g (P_1 + \text{Buildup})_{\text{abs}} \text{SIN} \left[\frac{3,417}{C_1} \sqrt{\frac{\Delta P}{P_1}} \right] \text{Deg.}$$

where,

Q = flow capacity in SCFH

G = specific gravity of gas

T = absolute temperature of gas at inlet in degrees Rankine

C_g = gas sizing coefficient from Table 3

P_{1abs} = absolute inlet pressure in psia
(P₁ gauge + 14.7)

C₁ = C_g/C_v from Table 3

ΔP = pressure drop across the valve in psig

Ordering Information

Refer to the Specifications on page 2. Carefully review each specification; then complete the Ordering Guide. If not otherwise specified, the pilot is factory set in the middle of the set pressure range.

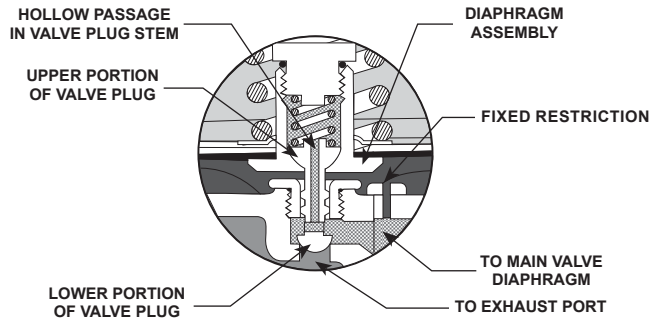

EXPANDED VIEW OF THE TYPE 6358B DIAPHRAGM ASSEMBLY AND VALVE PLUG (FOR USE WITH 1 AND 2 NPT BODY SIZES)

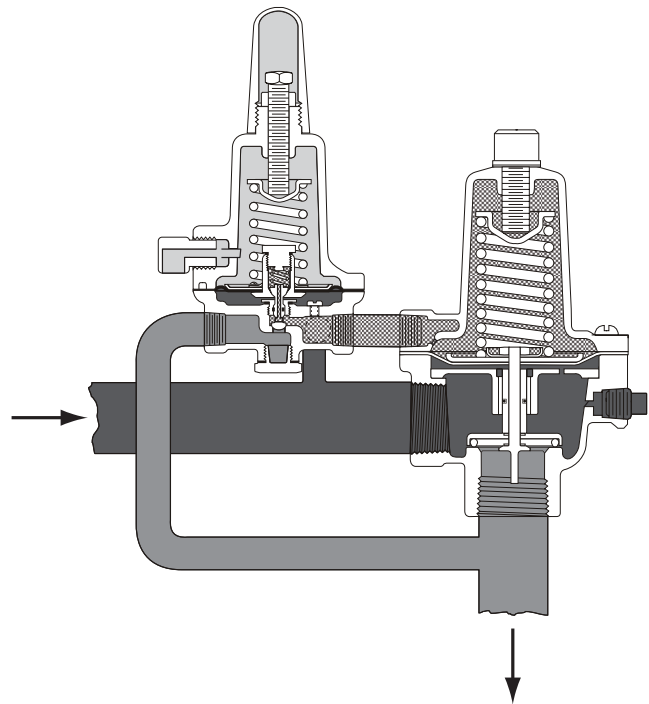

1 NPT TYPE 289P WITH TYPE 6358B PILOT

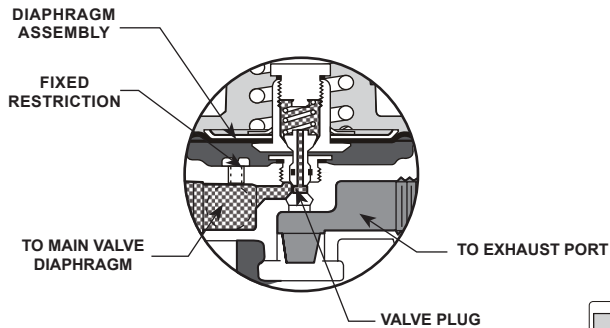

EXPANDED VIEW OF THE TYPE 6365 PILOT DIAPHRAGM ASSEMBLY AND VALVE PLUG (FOR USE WITH 2 NPT BODY SIZE ONLY)

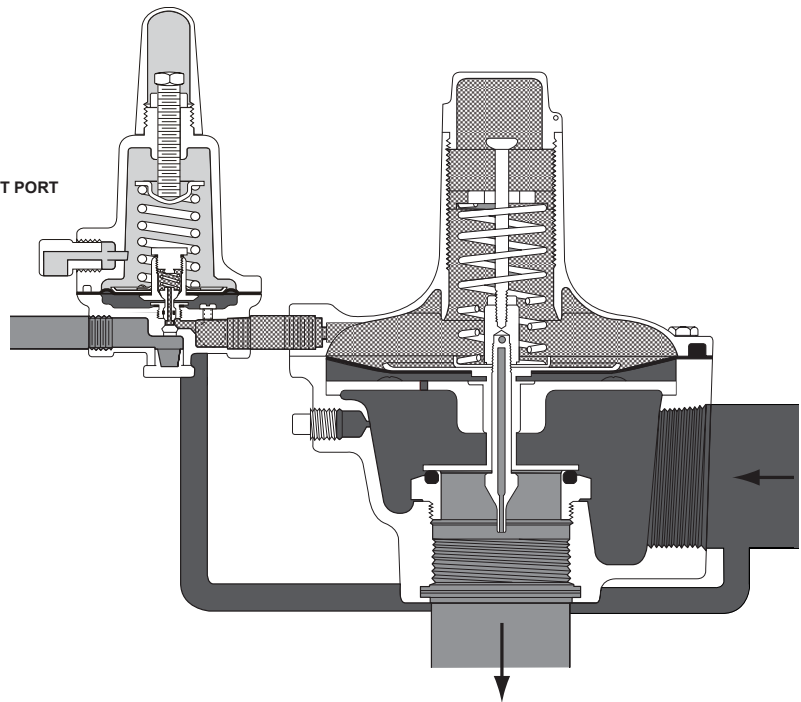

2 NPT TYPE 289P WITH TYPE 6358B PILOT

- INLET (CONTROLLED) PRESSURE
- OUTLET (EXHAUST) PRESSURE
- ATMOSPHERIC PRESSURE
- LOADING PRESSURE

Figure 3. Type 289P Operational Schematics

Bulletin 71.4:289P

Table 4. Wide-Open Flow Coefficients

1 NPT MAIN VALVE				2 NPT MAIN VALVE			
Inlet Piping Size	C_g	C_v	C_1	Inlet Piping Size	C_g	C_v	C_1
Line Size Equals Body Size [1-inch / 25 mm Inlet Piping]	740	23.1	32	Line Size Equals Body Size [2-inch / 51 mm Inlet Piping]	2,290	73.4	31.2
2:1 Line Size to Body Size Piping [2-inch / 51 mm Inlet Piping]	560	17.5		2:1 Line Size to Body Size Piping [4-inch / 102 mm Inlet Piping]	2,050	65.7	

1. Wide-open flow coefficients without outlet piping and outlet screen.

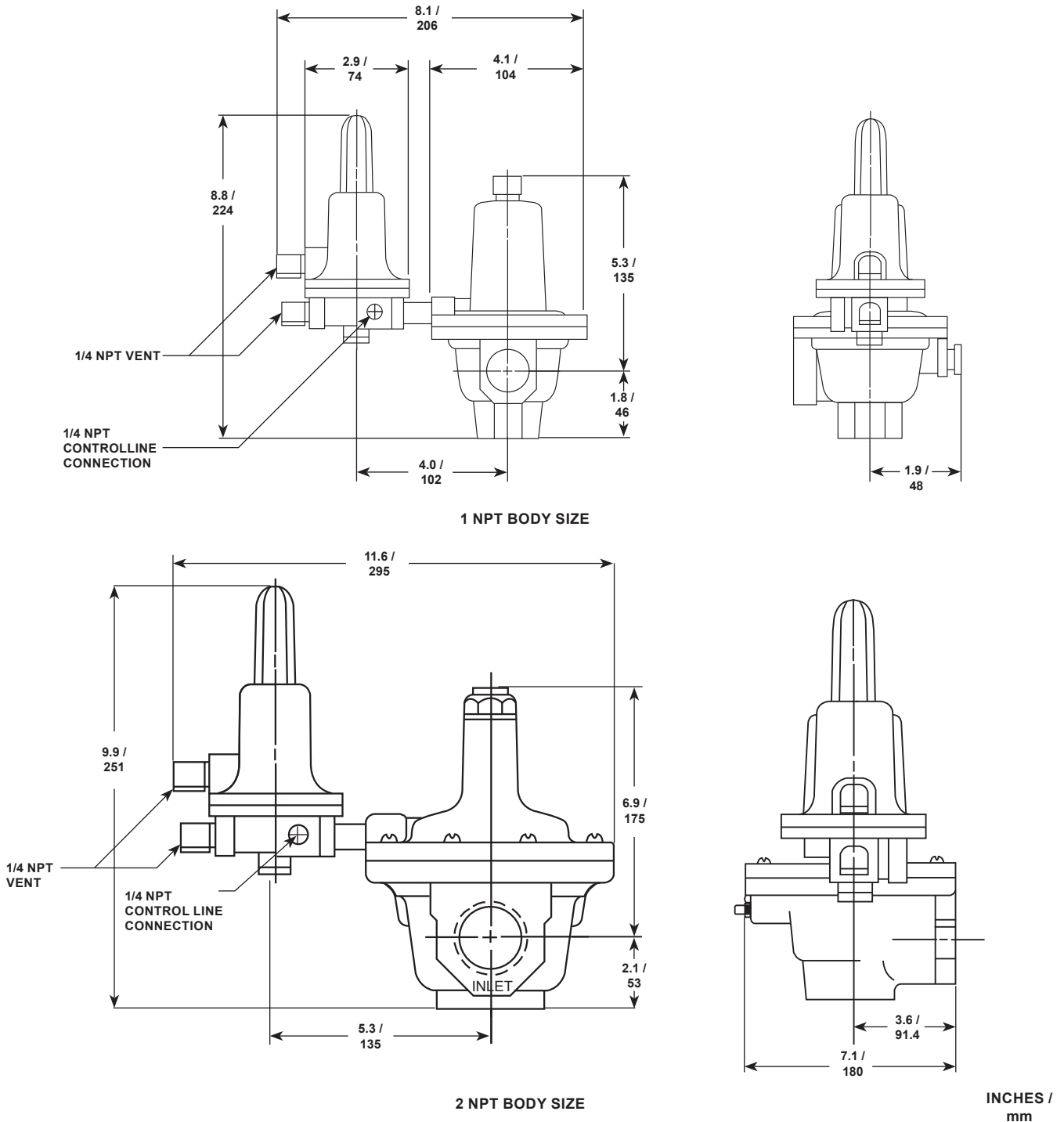

Figure 4. Dimensions

Ordering Guide

1 NPT Type 289P

Main Valve Diaphragm (Select One)

- Nitrile (NBR) **(standard)*****
- Fluorocarbon (FKM)*

Main Valve O-Rings (Select One)

- Nitrile (NBR) **(standard)*****
- Fluorocarbon (FKM)*

Main Valve Stem Guide Assembly (Select One)

- Brass with stainless steel bushing **(standard)*****
- Zinc with brass bushing**

Relief Set Pressure Range (Select One)

- 10 to 18 psig / 0.69 to 1.2 bar***
- 18 to 30 psig / 1.2 to 2.1 bar***
- 30 to 100 psig / 2.1 to 7.0 bar***

Pilot Valve Plug and Stem (Select One)

- Nitrile (NBR) **(standard)*****
- Fluorocarbon (FKM)*

Pilot Diaphragm (Select One)

- Nitrile (NBR) **(standard)*****
- Fluorocarbon (FKM)*

Pilot O-Rings and Gaskets (Select One)

- Nitrile (NBR) **(standard)*****
- Fluorocarbon (FKM)*

Main Valve Replacement Parts Kit (Optional)

- Yes, send one replacement parts kit to match this order.

Pilot Replacement Parts Kit (Optional)

- Yes, send one replacement parts kit to match this order.

2 NPT Type 289P

Relief Set Pressure Range (Select One)

Type 6365 Pilot

- 14-inches w.c. to 2 psig / 35 mbar to 0.14 bar, Yellow***

Type 6358B Pilot

- 2 to 10 psig / 0.14 to 0.69 bar, Black***

Type 6358B Pilot Valve Plug and Stem (Select One)

- Nitrile (NBR) **(standard)*****
- Fluorocarbon (FKM)*

Type 6358B Pilot Diaphragm (Select One)

- Nitrile (NBR) **(standard)*****
- Fluorocarbon (FKM)*

Type 6358B Pilot O-Rings and Gaskets (Select One)

- Nitrile (NBR) **(standard)*****
- Fluorocarbon (FKM)*

Main Valve Replacement Parts Kit (Optional)

- Yes, send one replacement parts kit to match this order.

Pilot Replacement Parts Kit (Optional)

- Yes, send one replacement parts kit to match this order.

Regulators Quick Order Guide	
***	Standard - Readily Available for Shipment
**	Non-Standard - Allow Additional Time for Shipment
*	Special Order, Constructed from Non-Stocked Parts. Consult your local Sales Office for Availability.
Availability of the product being ordered is determined by the component with the longest shipping time for the requested construction.	

Specification Worksheet

Application:
 Specific Use _____
 Line Size _____
 Gas Type and Specific Gravity _____
 Gas Temperature _____

Relief Valve Size:
 Brand of upstream regulator? _____
 Orifice size of the upstream regulator? _____
 Wide-open coefficient of the upstream regulator? _____

Pressure:
 Maximum Inlet Pressure (P_{1max}) _____
 Minimum Inlet Pressure (P_{1min}) _____
 Downstream Pressure Setting(s) (P_2) _____
 Maximum Flow (Q_{max}) _____

Performance Required:
 Accuracy Requirements? _____
 Need for Extremely Fast Response? _____

Other Requirements: _____

Industrial Regulators

Emerson Process Management Regulator Technologies, Inc.

USA - Headquarters
McKinney, Texas 75069-1872, USA
Tel: +1 800 558 5853
Outside U.S. +1 972 548 3574

Asia-Pacific
Shanghai 201206, China
Tel: +86 21 2892 9000

Europe
Bologna 40013, Italy
Tel: +39 051 419 0611

Middle East and Africa
Dubai, United Arab Emirates
Tel: +971 4811 8100

Natural Gas Technologies

Emerson Process Management Regulator Technologies, Inc.

USA - Headquarters
McKinney, Texas 75069-1872, USA
Tel: +1 800 558 5853
Outside U.S. +1 972 548 3574

Asia-Pacific
Singapore 128461, Singapore
Tel: +65 6770 8337

Europe
Bologna 40013, Italy
Tel: +39 051 419 0611
Gallardon 28320, France
Tel: +33 2 37 33 47 00

TESCOM

Emerson Process Management Tescom Corporation

USA - Headquarters
Elk River, Minnesota 55330-2445, USA
Tels: +1 763 241 3238
+1 800 447 1250

Europe
Selmsdorf 23923, Germany
Tel: +49 38823 31 287

Asia-Pacific
Shanghai 201206, China
Tel: +86 21 2892 9499

For further information visit www.emersonprocess.com/regulators

The Emerson logo is a trademark and service mark of Emerson Electric Co. All other marks are the property of their prospective owners. Fisher is a mark owned by Fisher Controls International LLC, a business of Emerson Process Management.

The contents of this publication are presented for informational purposes only, and while every effort has been made to ensure their accuracy, they are not to be construed as warranties or guarantees, express or implied, regarding the products or services described herein or their use or applicability. We reserve the right to modify or improve the designs or specifications of such products at any time without notice.

Emerson Process Management does not assume responsibility for the selection, use or maintenance of any product. Responsibility for proper selection, use and maintenance of any Emerson Process Management product remains solely with the purchaser.