

61 Series Pilots for Pilot-Operated Pressure Reducing Regulators

Introduction

61 Series pilots are used with Types 1098-EGR and EZL pressure reducing regulators. These pilots can also be integrally mounted to the actuator casing as used with 99 Series regulators.

61 Series pilots are available in a variety of constructions for low-pressure (L), high-pressure (H), and extra high-pressure (HP) applications. The low-pressure version is also available with wide (LE) or narrow (LD) proportional band.

Features

- **Standard and High-Temperature Materials Available**—Standard and high-temperature elastomers are available to satisfy a wide variety of application.
- **Wide Range of Available Constructions**—The 61 Series pilots are available in different constructions to meet a wide range of pressure application.
- **Highly Configurable for a Variety of Applications**—Configurable to be used for fast closing, fast opening, and monitoring applications.

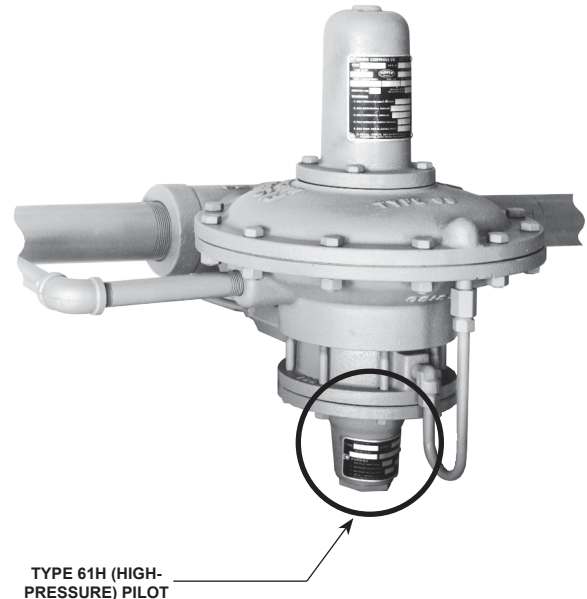

Figure 1. Type 99 Regulator with Type 61H (High-Pressure) Pilot

- **Includes a Type P593-1 or P594-1 Filter**—To remove dirt, scale, or other solid substances from upstream pilot supply gas for air or gas pressure regulators.

Table 1. Available Constructions

PILOT TYPE	DESCRIPTION	PRESSURE RANGE	
		psig	bar
61L	Low-Pressure Pilot	0.25 to 20	17 mbar to 1,4
61LD ⁽¹⁾	Low-Pressure Pilot with narrow proportional band		
61LE	Low-Pressure Pilot with wide proportional band		
61H	High-Pressure Pilot	10 to 65	0,69 to 4,5
61HP	Extra High-Pressure Pilot	15 to 300	1,0 to 20,7

1. Also available in 0 to 4-inches w.c. / 0 to 10 mbar and 3 to 12-inches w.c. / 7 to 30 mbar pressure range. See Table 2.



Bulletin 71.8:61

Specifications

Available Constructions

See Table 1

Reduced Pressure Ranges

See Table 2

Maximum Inlet Pressures⁽¹⁾

Types 61L, 61LE, and 61H⁽⁴⁾: 300 psig / 20,7 bar

Type 61LD: 160 psig / 11,0 bar

Type 61HP: 600 psig / 41,4 bar

Maximum Spring Case Pressure for Pressure Loading⁽¹⁾⁽³⁾

Types 61L, 61LD, 61LE: 25 psig / 1,7 bar

Type 61H: 72 psig / 5,0 bar

Type 61HP: 100 psig / 6,9 bar

Material Temperature Capabilities⁽¹⁾

Standard Elastomers: -20° to 150°F /

-29° to 66°C

High-Temperature Elastomers: 0° to 300°F /

-18° to 149°C, except 0° to 180°F / -18° to 82°C

for water service

Applications and Part Construction Requirements

Standard Applications: See Table 3

Fast Closing Applications: See Table 4

Fast Opening Applications: See Table 5

For Applications with Inlet Pressures to 400 psig / 27,6 bar (99 Series Only): See Table 6

Monitoring Applications: See Table 7

Pressure Connections

1/4 NPT (internal)

Construction Materials

Pilot

Body and Spring Case: Cast iron

Upper Relay Diaphragm: Nitrile (NBR) (for Types 61L, 61LD, 61LE, and 61H), Neoprene (CR) (for Type 61HP), or Fluorocarbon (FKM)

Lower Relay Diaphragm: Nitrile (NBR) (for Types 61L, 61LD, and 61LE),

Neoprene (CR) (for Types 61H and 61HP), or Fluorocarbon (FKM)

Composition Seats and O-rings: Nitrile (NBR) or Fluorocarbon (FKM)

Pilot Mounting Parts

Tubing: Stainless steel

Connector Fittings: Steel

Pipe Bushing: Steel

Pipe Nipples: Galvanized steel, Stainless steel

Type P593-1 and P594-1 Filters

Filter Body and Head: Aluminum (Type P593-1) or Brass (Type P594-1)

Gasket: Composition

Filter Material: Cellulose

Options

- Type 662 Remote Control Pilot Drive
- Handwheel⁽²⁾
- Adjusting screw cap⁽²⁾

1. The pressure/temperature limits in this Bulletin and any applicable standard or code limitation for this regulator pilot should not be exceeded.

2. For Types 61L, 61LD, and 61LE only.

3. For pressure-loaded spring case, maximum pressure for each spring range will be the maximum outlet pressure plus the maximum spring case loading pressure.

4. Type 61H pilot used with a 99 Series regulator can handle a maximum inlet pressure of 400 psig / 27,6 bar.

Table 2. Reduced Pressure Ranges

TYPE	PILOT CONTROL SPRING							
	Part Number	Reduced Pressure Ranges		Color Code	Wire Diameter		Free Length	
		psig	bar		Inches	mm	Inches	mm
61LD ⁽¹⁾	1B558527052	0 to 4-inches w.c.	0 to 10 mbar	Orange	0.072	1,83	3.78	96,0
	1C680627222	3 to 12-inches w.c.	7 to 30 mbar	Unpainted	0.080	2,03	3.00	76,2
61L, 61LD ⁽¹⁾ , 61LE ⁽²⁾	1B886327022	0.25 to 2	17 mbar to 0,14	Red	0.109	2,77	2.75	69,9
	1J857827022	1 to 5	69 mbar to 0,35	Yellow	0.142	3,61	2.75	69,9
	1B886427022	2 to 10	0,14 to 0,69	Blue	0.172	4,37	2.88	73,2
	1J857927142	5 to 15	0,35 to 1,0	Brown	0.187	4,75	3.03	77,0
	1B886527022	10 to 20	0,69 to 1,4	Green	0.207	5,26	3.18	80,8
61H	0Y066427022	10 to 65	0,69 to 4,5	Green Stripe	0.363	9,22	6.00	152
61HP	1E392527022	15 to 45	1,0 to 3,1	Yellow	0.148	3,76	2.00	50,8
	1D387227022	35 to 100	2,4 to 6,9	Blue	0.200	5,08	1.69	42,9
	1D465127142	100 to 300	6,9 to 20,7	Red	0.243	6,17	1.69	42,9

1. Type 61LD construction has narrower proportional band than the standard Type 61L Pilot.

2. Type 61LE construction has wider proportional band than the standard Type 61L Pilot.

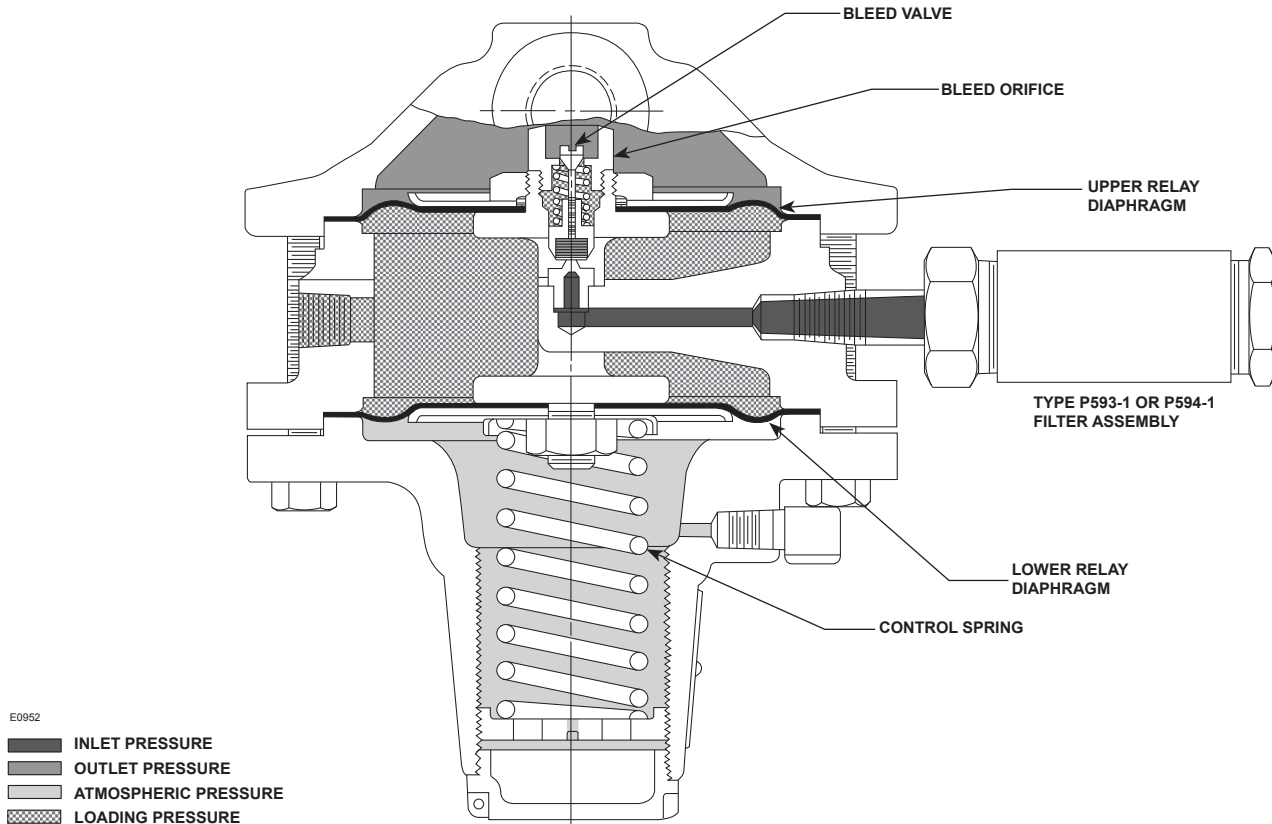

Figure 2. Type 61L Pilot Regulator Operational Schematic

Applications Information

Tables 3 through 7 and Figure 3 show which parts are included in each of the available constructions (see Table 1). For the required parts, simply match the numbers listed in the tables with the corresponding numbers in Figure 3.

The tables also show the maximum allowable inlet pressure to the pilot and the maximum allowable differential pressure across the bleed valve.

Principle of Operation

Refer to Figure 2. Pilot-operated regulators such as Types 1098-EGR and EZL use inlet pressure as the operating medium, which is reduced through pilot operation to load the actuator diaphragm. Outlet or downstream pressure opposes loading pressure in the actuator and also opposes the pilot control spring.

In operation, assume that outlet pressure is below the pilot control setting. Control spring force on

the pilot diaphragm thus opens the pilot valve plug providing additional loading pressure to the actuator diaphragm. This loading pressure forces the actuator stem forward, opening the main valve plug via a bump connection. The upward motion of the plug allows gas to flow through the cage into the downstream system.

When downstream demand has been satisfied, outlet pressure tends to increase, acting on the pilot and actuator diaphragm. This pressure exceeds the pilot control spring setting, moving the pilot diaphragm away and letting the valve plug spring close the pilot valve plug (unbalanced in the 61 Series Pilots). Excess loading pressure on the actuator diaphragm escapes downstream through the bleed orifice.

Reduced actuator loading pressure permits the main valve to close. The combination of main valve spring force and valve plug unbalance provides positive valve plug shutoff against the port and upper seals. An external relief valve (Type 1806) is required when using the 61 Series pilots.

Bulletin 71.8:61

Table 3. For Standard Applications

PILOT TYPE	PARTS REQUIRED ⁽¹⁾ (SEE FIGURE 3)	MAXIMUM INLET PRESSURE ⁽²⁾⁽⁴⁾		MAXIMUM DIFFERENTIAL PRESSURE ACROSS BLEED VALVE ⁽³⁾	
		psig	bar	psig	bar
61L	1, 3, 5, 8, 11, 14	300	20,7	35	2,4
61LD	1, 3, 6, 9, 11, 14	160	11,0	15	1,0
61LE	2, 3, 5, 8, 11, 14	300	20,7	35	2,4
61H	2, 4, 5, 8, 11, 14				

1. Choice of part 11, 12, or 13 depends on speed of response desired and maximum inlet pressure.
2. Maximum inlet pressure to the pilot is the highest pressure at which the relay orifice can shut off and is dependent on selection of relay orifice, relay spring, and bleed valve.
3. Maximum differential pressure across bleed valve is the largest allowable difference between the pilot loading pressure and the downstream controlled pressure, and is dependent on selection of relay spring and bleed valve. If these values are exceeded on monitoring applications, specify bleed orifice 1D7771 and bleed orifice cap 1D7772.
4. The pressure/temperature limits in this Bulletin and any applicable standard or code limitation should not be exceeded.

Table 4. For Fast Closing Applications

PILOT TYPE	PARTS REQUIRED ⁽¹⁾ (SEE FIGURE 3)	MAXIMUM INLET PRESSURE ⁽²⁾⁽⁴⁾		MAXIMUM DIFFERENTIAL PRESSURE ACROSS BLEED VALVE ⁽³⁾	
		psig	bar	psig	bar
61L	1, 3, 5, 8, 12, 15	160	11,0	35	2,4
61LD	1, 3, 6, 9, 12, 15	70	4,8	15	1,0
61H	2, 4, 5, 8, 12, 15	160	11,0	35	2,4

1. Choice of part 11, 12, or 13 depends on speed of response desired and maximum inlet pressure.
2. Maximum inlet pressure to the pilot is the highest pressure at which the relay orifice can shut off and is dependent on selection of relay orifice, relay spring, and bleed valve.
3. Maximum differential pressure across bleed valve is the largest allowable difference between the pilot loading pressure and the downstream controlled pressure, and is dependent on selection of relay spring and bleed valve. If these values are exceeded on monitoring applications, specify bleed orifice 1D7771 and bleed orifice cap 1D7772.
4. The pressure/temperature limits in this Bulletin and any applicable standard or code limitation should not be exceeded.

Table 5. For Fast Opening Applications

PILOT TYPE	PARTS REQUIRED ⁽¹⁾ (SEE FIGURE 3)	MAXIMUM INLET PRESSURE ⁽²⁾⁽⁴⁾		MAXIMUM DIFFERENTIAL PRESSURE ACROSS BLEED VALVE ⁽³⁾	
		psig	bar	psig	bar
61L	1, 3, 5, 8, 12, 14	160	11,0	35	2,4
	1, 3, 5, 8, 13, 14	60	4,1		
61LD	1, 3, 6, 9, 12, 14	70	4,8	15	1,0
	1, 3, 6, 9, 13, 14	25	1,7		
61H	2, 4, 5, 8, 12, 14	165	11,4	35	2,4

1. Choice of part 11, 12, or 13 depends on speed of response desired and maximum inlet pressure.
2. Maximum inlet pressure to the pilot is the highest pressure at which the relay orifice can shut off and is dependent on selection of relay orifice, relay spring, and bleed valve.
3. Maximum differential pressure across bleed valve is the largest allowable difference between the pilot loading pressure and the downstream controlled pressure, and is dependent on selection of relay spring and bleed valve. If these values are exceeded on monitoring applications, specify bleed orifice 1D7771 and bleed orifice cap 1D7772.
4. The pressure/temperature limits in this Bulletin and any applicable standard or code limitation should not be exceeded.

Table 6. For Applications with Inlet Pressures to 400 psig / 27,6 bar (99 Series Only)

PILOT TYPE	PARTS REQUIRED ⁽¹⁾ (SEE FIGURE 3)	MAXIMUM INLET PRESSURE ⁽²⁾⁽⁴⁾		MAXIMUM DIFFERENTIAL PRESSURE ACROSS BLEED VALVE ⁽³⁾	
		psig	bar	psig	bar
61H	2, 4, 5, 10, 11, 14	400	27,6	50	3,4

1. Choice of part 11, 12, or 13 depends on speed of response desired and maximum inlet pressure.
2. Maximum inlet pressure to the pilot is the highest pressure at which the relay orifice can shut off and is dependent on selection of relay orifice, relay spring, and bleed valve.
3. Maximum differential pressure across bleed valve is the largest allowable difference between the pilot loading pressure and the downstream controlled pressure, and is dependent on selection of relay spring and bleed valve.
4. The pressure/temperature limits in this Bulletin and any applicable standard or code limitation should not be exceeded.

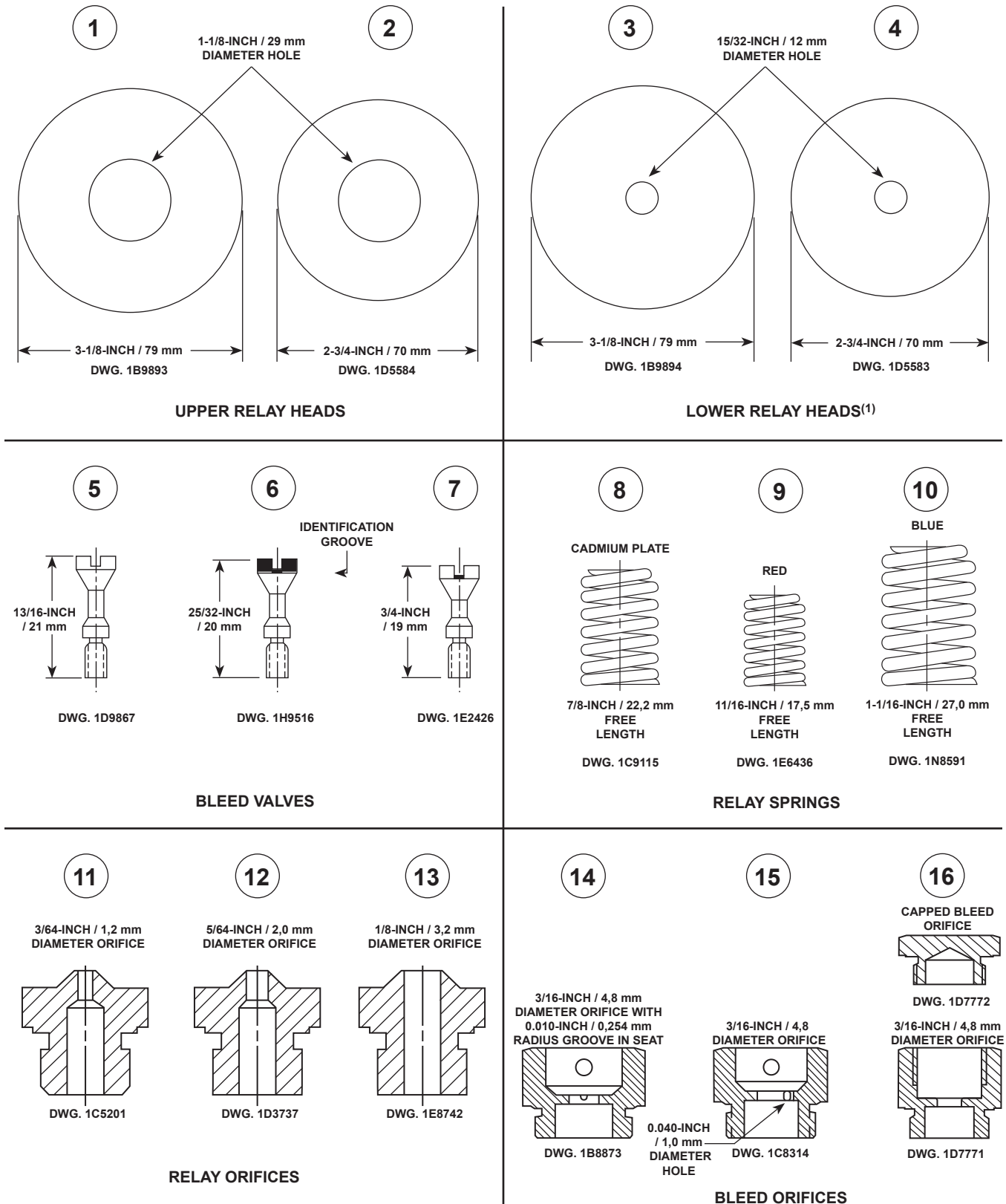

1. Lower Relay Head is near the spring case end of pilot.

Figure 3. Available Options for Different Construction Parts (Applicable to 61 Series except Type 61HP)

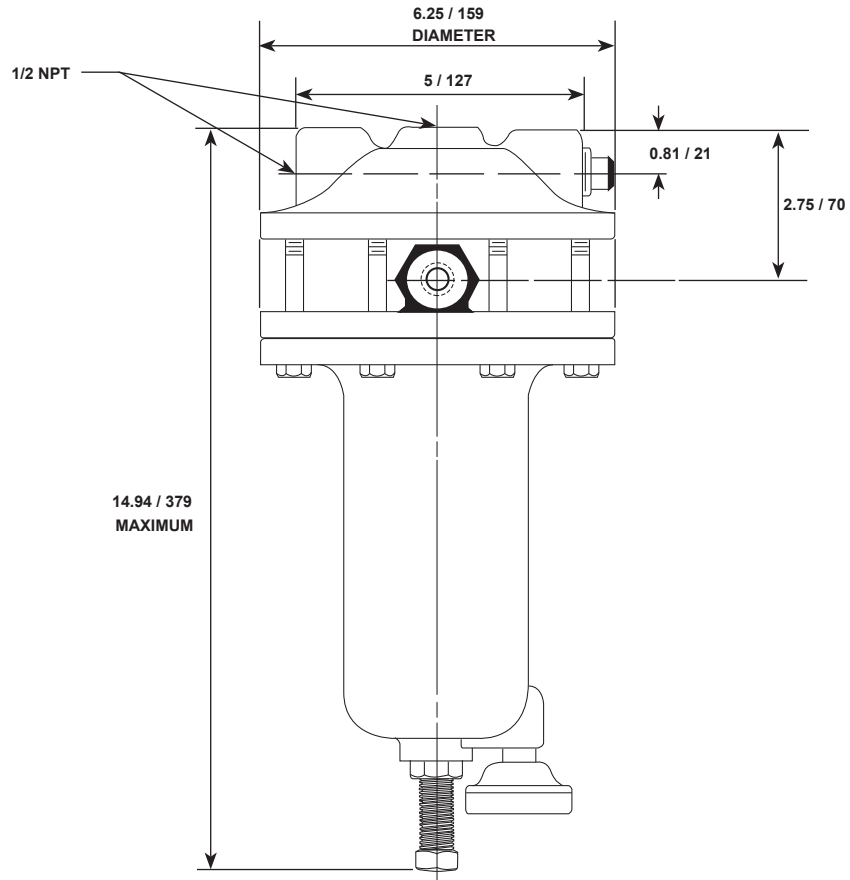

AJ9070

TYPE 61H

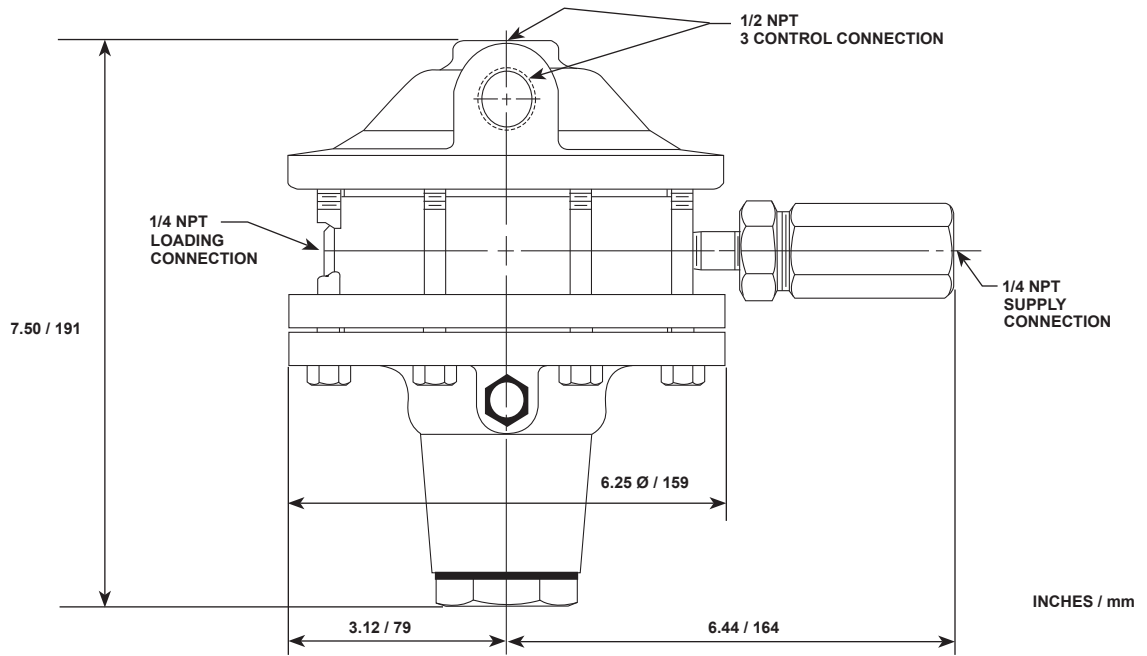

1F3977

TYPE 61L

Figure 4. Dimensions

Table 7. For Monitoring Applications

PILOT TYPE	PARTS REQUIRED ⁽¹⁾ (SEE FIGURE 3)	MAXIMUM INLET PRESSURE ⁽²⁾⁽⁴⁾		MAXIMUM DIFFERENTIAL PRESSURE ACROSS BLEED VALVE ⁽³⁾	
		psig	bar	psig	bar
61LD Special (Wide-Open Monitor Applications)	1, 3, 7, 9, 11, 15	60	4,1	10	0,69
61L (Working Monitor Applications, Working Pilot)	1, 3, 5, 8, 11, 16	300	20,7	10	0,69
61LD (Working Monitor Applications, Monitor Pilot)	1, 3, 6, 9, 11, 16	160	11,0	10	0,69

1. Choice of part 11, 12, or 13 depends on speed of response desired and maximum inlet pressure.
 2. Maximum inlet pressure to the pilot is the highest pressure at which the relay orifice can shut off and is dependent on selection of relay orifice, relay spring, and bleed valve.
 3. Maximum differential pressure across bleed valve is the largest allowable difference between the pilot loading pressure and the downstream controlled pressure, and is dependent on selection of relay spring and bleed valve. If these values are exceeded on monitoring applications, specify bleed orifice 1D7771 and bleed orifice cap 1D7772.
 4. The pressure/temperature limits in this Bulletin and any applicable standard or code limitation should not be exceeded.

Ordering Information

Application

When ordering, specify:

1. Type of service—liquid or gas service
2. Nature and specific gravity of controlled fluid (including chemical analysis if possible)
3. Fluid temperature
4. Range of flowing inlet pressures and pressure drops
5. Desired set pressure

Construction

Refer to the Specifications section on page 2. Review the description to the right of each specification and in the referenced tables; specify the desired selection wherever there is a choice to be made.

Always specify the type number of other desired equipment as well as the pilot. The standard-gain pilot restriction will be provided automatically unless an optional-gain restriction is ordered.

Ordering Guide

Type (Select One)

- 61L (low-pressure)^{***}
- 61LE (low-pressure, wide proportional band)^{***}
- 61LD (low-pressure, narrow proportional band)^{***}
- 61H (high-pressure)^{***}
- 61HP (extra high-pressure)^{***}

Reduced Pressure Range (Select One)

Type 61LD

- 0 to 4-inches w.c. / 0 to 10 mbar, Orange*
- 3 to 12-inches w.c. / 7 to 30 mbar, Unpainted*

Types 61L, 61LE, and 61LD

- 0.25 to 2 psig / 17 mbar to 0,14 bar, Red^{***}
- 1 to 5 psig / 69 mbar to 0,35 bar, Yellow^{***}
- 2 to 10 psig / 0,14 to 0,69 bar, Blue^{***}
- 5 to 15 psig / 0,35 to 1,0 bar, Brown^{***}
- 10 to 20 psig / 0,69 to 1,4 bar, Green^{***}

Type 61H

- 10 to 65 psig / 0,69 to 4,5 bar, Green Stripe^{***}

Type 61HP

- 15 to 45 psig / 1,0 to 3,1 bar, Yellow^{***}
- 35 to 100 psig / 2,4 to 6,9 bar, Blue^{***}
- 100 to 300 psig / 6,9 to 20,7 bar, Red^{***}

Optional

- Type 662 Remote Control Pilot Drive
- Pressure-Loaded Spring Case
- Handwheel Adjusting Screw (for Types 61L, 61LE, 61LD only)

Repair Parts Kits (Optional)

- Yes, send one repair parts kit to match this order

Regulators Quick Order Guide	
***	Readily Available for Shipment
**	Allow Additional Time for Shipment
*	Special Order, Constructed from Non-Stocked Parts. Consult Your local Sales Office for Availability.
Availability of the product being ordered is determined by the component with the longest shipping time for the requested construction.	

Specification Worksheet

Application (Please designate units):
 Specific Use _____
 Line Size _____
 Gas Type and Specific Gravity _____
 Gas Temperature _____
 Does the Application Require Overpressure Protection?
 Yes No If yes, which is preferred:
 Relief Valve Monitor Regulator
 Shut-off Device
 Is overpressure protection equipment selection assistance desired? _____

Pressure (Please designate units):
 Maximum Inlet Pressure (P_{1max}) _____
 Minimum Inlet Pressure (P_{1min}) _____
 Downstream Pressure Setting(s) (P_2) _____
 Maximum Flow (Q_{max}) _____

Performance Required: _____
 Accuracy Requirements? _____
 Need for Extremely Fast Response? _____

Other Requirements: _____

Industrial Regulators

Emerson Process Management Regulator Technologies, Inc.

USA - Headquarters
 McKinney, Texas 75069-1872, USA
 Tel: +1 800 558 5853
 Outside U.S. +1 972 548 3574

Asia-Pacific
 Shanghai 201206, China
 Tel: +86 21 2892 9000

Europe
 Bologna 40013, Italy
 Tel: +39 051 419 0611

Middle East and Africa
 Dubai, United Arab Emirates
 Tel: +971 4811 8100

Natural Gas Technologies

Emerson Process Management Regulator Technologies, Inc.

USA - Headquarters
 McKinney, Texas 75069-1872, USA
 Tel: +1 800 558 5853
 Outside U.S. +1 972 548 3574

Asia-Pacific
 Singapore 128461, Singapore
 Tel: +65 6770 8337

Europe
 Bologna 40013, Italy
 Tel: +39 051 419 0611
 Gallardon 28320, France
 Tel: +33 2 37 33 47 00

TESCOM

Emerson Process Management Tescom Corporation

USA - Headquarters
 Elk River, Minnesota 55330-2445, USA
 Tels: +1 763 241 3238
 +1 800 447 1250

Europe
 Selmsdorf 23923, Germany
 Tel: +49 38823 31 287

Asia-Pacific
 Shanghai 201206, China
 Tel: +86 21 2892 9499

For further information visit www.fisherregulators.com

The Emerson logo is a trademark and service mark of Emerson Electric Co. All other marks are the property of their prospective owners. Fisher is a mark owned by Fisher Controls, Inc., a business of Emerson Process Management.

The contents of this publication are presented for informational purposes only, and while every effort has been made to ensure their accuracy, they are not to be construed as warranties or guarantees, express or implied, regarding the products or services described herein or their use or applicability. We reserve the right to modify or improve the designs or specifications of such products at any time without notice.

Emerson Process Management does not assume responsibility for the selection, use or maintenance of any product. Responsibility for proper selection, use and maintenance of any Emerson Process Management product remains solely with the purchaser.