

April 2021

Type 92S Pilot-Operated Steam Regulator

Introduction

The Type 92S steam regulator is piston actuated for high cycle steam service which includes a Type 6492L, 6492H or 6492HT pilot (see Figure 1). These pilots have bellows sealed stems to eliminate stem guide friction. The valve and pilot use lapped seating surfaces that have been proven to minimize seat leakage.

Features

- **Good Shutoff for Low Downstream Build-up**—Type 92S main valve and Types 6492H, 6492L and 6492HT pilots are machine-lapped seating surfaces that have been time-proven to minimize seat leakage when the downstream demand is zero and the regulator is shutoff.
- **Resistance to Piping Stresses**—Steel constructions are available to help resist the piping stresses commonly encountered in steam applications.
- **Ease of Installation**—Compact construction reduces installation space requirements. Supply of pressure to the pilot is supplied from the inlet side of the main valve through factory piped tubing; with a standard pilot, this means no separate pilot supply pressure is required.
- **Increased Sensitivity to Downstream Pressure Changes**—Friction-reducing bellows seal on the pilot stem and large pilot diaphragm areas yield good sensitivity.
- **Ease of Pilot Maintenance**—Pilot valve plug and seat can be removed for inspection of maintenance without disassembling piping connections and without removing the diaphragm. Pilot inlet screen (Figure 2) is easily removed with the seating parts for inspection and cleaning. Diaphragm can be removed without disturbing the seating parts.
- **Noise Reduction Capability Without Decrease in Capacity**—A noise attenuation trim is available for use with NPS 2 / DN 50 and larger main valve sizes

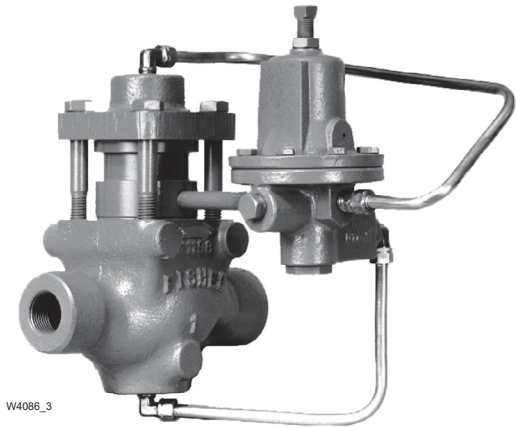

W4086_3

1 NPT STEEL
MAIN VALVE WITH TYPE 6492H OR 6492HT PILOT

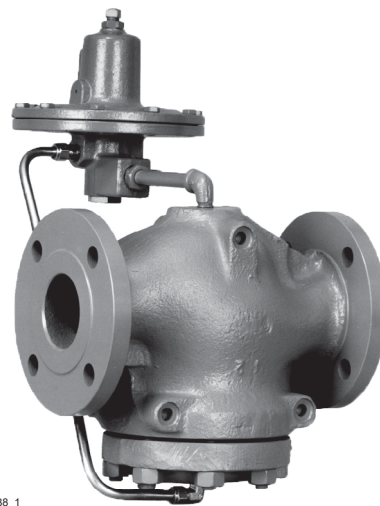

W4088_1

NPS 3 / DN 80 FLANGED CAST IRON
MAIN VALVE WITH TYPE 6492L PILOT

Figure 1. Type 92S Pilot-Operated Steam Regulator

to provide an economical yet full-flow means for the reduction of noise from high velocity steam flow. Further noise reduction of the system can be achieved by the use of a heavier piping schedule and/or thermal insulation of the attached piping.

Type 92S

Specifications

This section lists the specifications for the Type 92S regulator. Factory specifications are stamped on the nameplate fastened on the regulator at the factory.

Main Valve Body Sizes and End Connection Styles

BODY SIZES	END CONNECTION STYLES AND RATINGS	
	Cast Iron Body	Steel or Stainless Steel Body
1, 1-1/2 and 2	NPT	NPT or PN 16/25/40
NPS 1, 1-1/2, 2, 2-1/2, 3 and 4 / DN 25, 40, 50, 65, 80 and 100	CL125 FF or CL250 RF	CL150 RF, CL300 RF, CL600 RF or PN 16/25/40
NPS 6 x 4 / DN 150 x 100 ⁽²⁾	Not available	CL300 RF, CL600 RF or PN 16/25-40/64/100

Maximum Inlet and Pilot Supply Pressure⁽¹⁾

Cast Iron Main Valve and Pilot: 250 psig / 17.2 bar or body rating limit, whichever is lower

Steel Main Valve and Pilot: 300 psig / 20.7 bar or body rating limit, whichever is lower

Minimum and Maximum Differential Pressures⁽¹⁾

BODY SIZES, NPS / DN	MINIMUM DIFFERENTIAL PRESSURE	MAXIMUM DIFFERENTIAL PRESSURE
1, 1-1/2 and 2 / 25, 40 and 50	15 psi / 1.0 bar	200 psi / 13.8 bar or body rating limit, whichever is lower
2-1/2, 3, 4 and 6 x 4 / 65, 80, 100 and 150 x 100 ⁽²⁾	20 psi / 1.4 bar	175 psi / 12.1 bar or body rating limit, whichever is lower

Outlet (Control) Pressure Ranges

See Table 1

Maximum Outlet Pressures⁽¹⁾

See Table 2

Maximum Allowable Loading Pressure for Pilot with Tapped Spring Case

Combination of pilot control spring setting and spring case loading pressure cannot exceed 150 psig / 10.3 bar for Type 6492H pilot or 25 psig / 1.7 bar for Type 6492L pilot and 250 psig / 17.2 bar for Type 6492HT

Droop

See Table 5 and Figure 8

Typical Regulating Capacities

See Table 5 and Capacity Information section

Main Valve Orifice Sizes and Flow Coefficients

See Table 3

Noise Information

See Table 6 and Noise Abatement Information section

Construction Materials

Main Valve

Body and Body Flange: Cast iron (NPS 1 through 4 / DN 25 through 100 sizes only), Steel or CF8M Stainless steel (all sizes)

Valve Plug: Heat-treated 17-4PH Stainless steel

Cage: Cast iron or Stainless steel

Spiral Wound Gasket: 316L Stainless steel and graphite

Spring, Lower Stem, Retaining Ring, Bolting and Cylinder Spacer: Steel or Plated steel

Body and Cylinder Gaskets: Copper

Pistons, Seat Ring and Cylinders: Heat-treated 416 Stainless steel

Piston Ring(s): Polytetrafluoroethylene (PTFE)

Piston Ring Retainer(s): 302 Stainless steel

Noise Attenuation Trim (If used): Stainless steel

Stem Seal: PTFE/glass

Pilot

Body and Spring Case: Cast iron, Steel and Stainless steel

Seat Ring and Stem: Heat-treated

416 Stainless steel

Bellows and Bellows Retainer: Brass

Plug, Plug Guide, Plug Spring, Diaphragms, Bleed

Restriction and Inlet Screen: Stainless steel

Diaphragm Gasket: Flexible Graphite

Control Spring, Upper Spring Seat, Adjusting Screw, Bolting, Pipe Plug, Reducing Bushing and (If used)

Diaphragm Plate: Steel

Fittings: Brass

Tubing: Copper

Pipe Nipple: Steel

1. The pressure/temperature limits in this Bulletin and any applicable standard or code limitations, must not be exceeded.

2. The two-number designation indicates line size by trim size.

- continued -

Specifications (continued)

Maximum Temperature Capabilities⁽¹⁾

Cast Iron Main Valve and Pilot: 406°F / 208°C

Steel Main Valve and Pilot: 500°F / 260°C

High Temperature Optional Steel and

Stainless steel Main Valve and Pilot:

650°F / 343°C

Downstream Control Line Connection

NPS 1, 1-1/2 and 2 / DN 25, 40 and 50

Main Valve Sizes: 1/4 NPT in main valve

cylinder spacer

NPS 2-1/2, 3, 4 and 6 x 4 / DN 65, 80, 100

and 150 x 100⁽²⁾ Main Valve Sizes: 1/4 NPT in pilot body

Pilot Spring Case Vent

Standard: 1/8 in. / 3.18 mm drilled hole

Optional: 1/4 NPT tapping for pressure loading or on-off service

Pressure Registration

External through downstream control line

Approximate Weights

BODY SIZE		END CONNECTIONSTYLE	APPROXIMATE WEIGHTS		
NPS	DN		lbs	kg	
1 1-1/2	25	NPT or flanged NPT or flanged	32	15	
	40		44	20	
2	50	NPT Flanged	55	25	
			67	30	
2-1/2 3 4	65 80 100	Flanged Flanged Flanged	90	41	
			115	52	
			165	75	
6 x 4 ⁽²⁾	150 x 100 ⁽²⁾	Flanged	CL300	335	152
			CL600	435	197

1. The pressure/temperature limits in this Bulletin and any applicable standard or code limitations, must not be exceeded.

2. The two-number designation indicates line size by trim size.

Table 1. Outlet (Control) Pressure Ranges

PILOT TYPE	OUTLET PRESSURE RANGES		PART NUMBER	COLOR CODE	SPRING WIRE DIAMETER		SPRING FREE LENGTH	
	psig	bar			In.	mm	In.	mm
6492L	2 to 6	0.14 to 0.41	1E395627022	Yellow	0.207	5.26	2.50	63.5
	5 to 15	0.35 to 1.0	1D7455T0012	Green	0.234	5.94	2.62	66.6
	13 to 25	0.90 to 1.7	1E395727192	Red	0.283	7.19	2.44	62.0
6492H	10 to 30	0.69 to 2.1	1E395627022	Yellow	0.207	5.26	2.50	63.5
	25 to 75	1.7 to 5.2	1D7455T0012	Green	0.234	5.94	2.62	66.6
	70 to 150	4.8 to 10.3	1E395727192	Red	0.283	7.19	2.44	62.0
6492HT	15 to 100	1.0 to 6.9	14B9943X012	Unpainted	0.282	7.16	2.50	63.5
	80 to 250	5.5 to 17.2	14B9942X012		0.375	9.53	2.50	63.5

Table 2. Maximum Inlet and Outlet Pressures

CONSTRUCTION	MAXIMUM ALLOWABLE INLET PRESSURE				MAXIMUM OPERATING OUTLET PRESSURE		MAXIMUM EMERGENCY OUTLET PRESSURE	
	Cast Iron		Steel and Stainless Steel				Cast Iron Main Valve and Pilot Body	Steel or Stainless Steel Main Valve and Pilot Body
	psig	bar	psig	bar	psig	bar		
with Type 6492HT pilot	----		300	20.7	250	17.2	----	300 psig / 20.7 bar or main valve body rating limit, whichever is lower
with Type 6492H pilot	250	17.2			150	10.3	250 psig / 17.2 bar or main valve body rating limit, whichever is lower	300 psig / 20.7 bar or main valve body rating limit, whichever is lower
with Type 6492L pilot					25	1.7	100 psig / 6.9 bar	100 psig / 6.9 bar

Type 92S

Table 3. Flow and Sizing Coefficients⁽¹⁾

BODY SIZE		ORIFICE SIZE		REGULATING C _s	WIDE-OPEN C _v FOR RELIEF SIZING	C _i	K _m	IEC SIZE COEFFICIENTS		
NPS	DN	In.	mm					X _T	F _D	F _L
1	25	7/8	22	16	17.5	34	0.62	0.73	0.51	0.79
1-1/2	40	1-1/8	29	30	33				0.47	
2	50	1-29/64	37	48	52				0.48	
2-1/2	65	1-5/8	41	74	78		0.71	0.73	0.48	0.84
3	80	2-1/16	52	100	110				0.47	
4	100	2-3/8	60	140	145				0.46	
6 x 4	150 x 100	2-3/8	60	150	155			0.46		

1. $C_v = C_s \times 20 + C_i$

- **Lapped Seats for Tight Shutoff**—The valve and pilot use lapped seating surfaces that have been proven to minimize seat leakage.
- **Application Flexibility**—Pilot with optional tapped spring case is available for use either with an air loading regulator for remote adjustment of outlet pressure setting or when all compression is removed from the pilot control spring, with a solenoid or switching valve for on-off service.

reducing flow to the downstream system in response to the decreased demand.

With a pilot for pressure-loaded service (Figure 7), the operation is the same as for a standard pilot except that the pilot control spring force on the pilot valve plug is aided by pneumatic pressure from the loading device. With a pilot for on-off service, the only force acting on top of the pilot diaphragm is pneumatic pressure provided by the solenoid or switching valve.

Principle of Operation

Pilot supply pressure is piped from the main valve inlet (Figure 2) to the pilot inlet connection. Downstream pressure registers on the main valve pistons through the downstream control line and then on the pilot diaphragm.

When increased downstream demand lowers the downstream pressure to a value below the setting of the pilot control spring, this forces the pilot valve plug to open increasing the loading pressure on the main valve pistons. At the same time, the increased demand lowers the downstream pressure on the main valve piston(s). This opens the main valve plug, increasing flow to the downstream system to satisfy the increased demand and to restore downstream pressure to the setting of the pilot control spring.

Decreased downstream demand increases the downstream pressure registered on the pilot diaphragm. The increased pressure overcomes the force of the pilot control spring and allows the pilot valve plug spring to close the valve plug. As the pilot valve plug closes, excess loading pressure bleeds to the downstream system through the pilot bleed restriction. At the same time, decreased downstream demand increases the downstream pressure registered on the main valve piston(s). This allows the main valve spring to close the main valve plug,

Installation

The Type 92S regulator should be installed and used in accordance with governmental codes and regulations. Although this regulator minimizes leakage under shutoff conditions, downstream overpressure protection must be provided by the user. The pressure and temperature limitations in the Specifications section must be observed and the downstream equipment protected.

A Type 92S regulator may be installed in any orientation, but should not be installed in a tall vertical pipeline where condensate could collect and create a pressure head affecting regulator performance. To obtain maximum flow capacities in some instances, outlet piping will have to be swaged up above the given body size.

A downstream control line is required but is not furnished with the Type 92S regulator. Additionally, an adjustable loading pressure regulator and loading pressure piping are required for pressure-loading pilot regulators, while an on-off or solenoid valve is required for on-off pilot regulators.

Dimensions are shown in Figure 9.

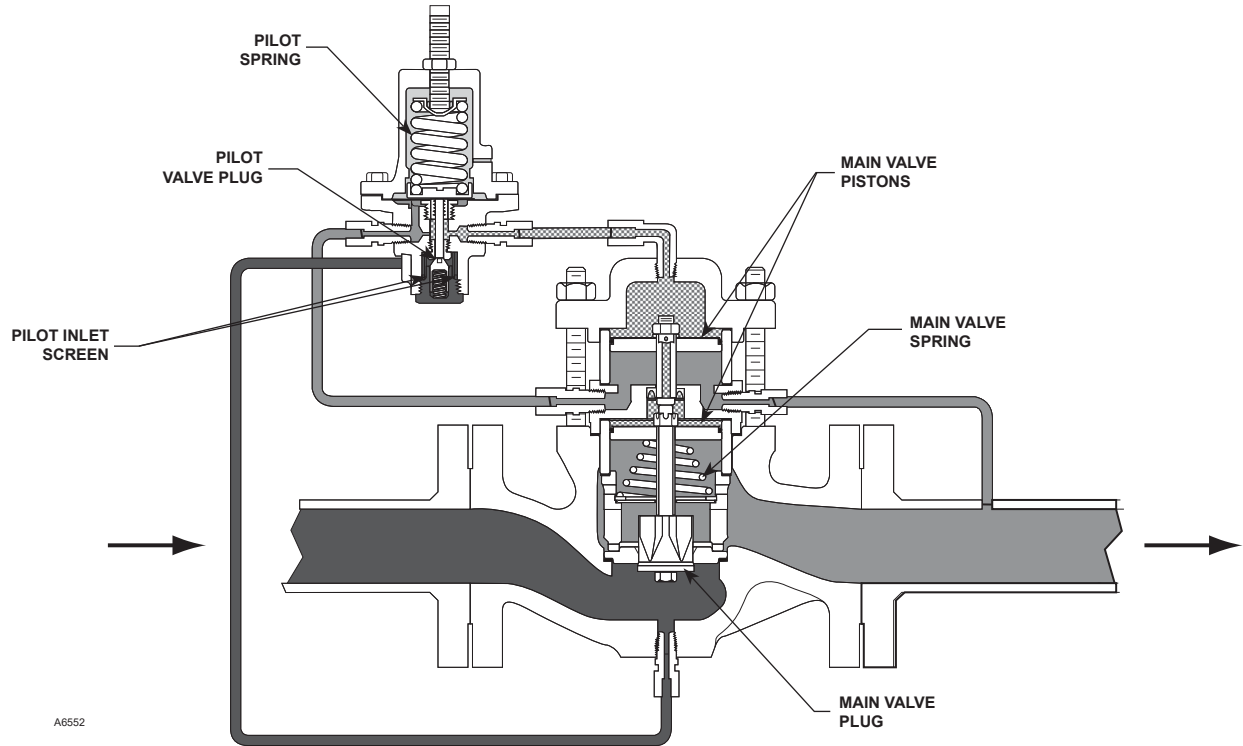

A6552

NPS 1, 1-1/2 OR 2 / DN 25, 40 OR 50
MAIN VALVE BODY AND TYPE 6492H OR 6492HT PILOT

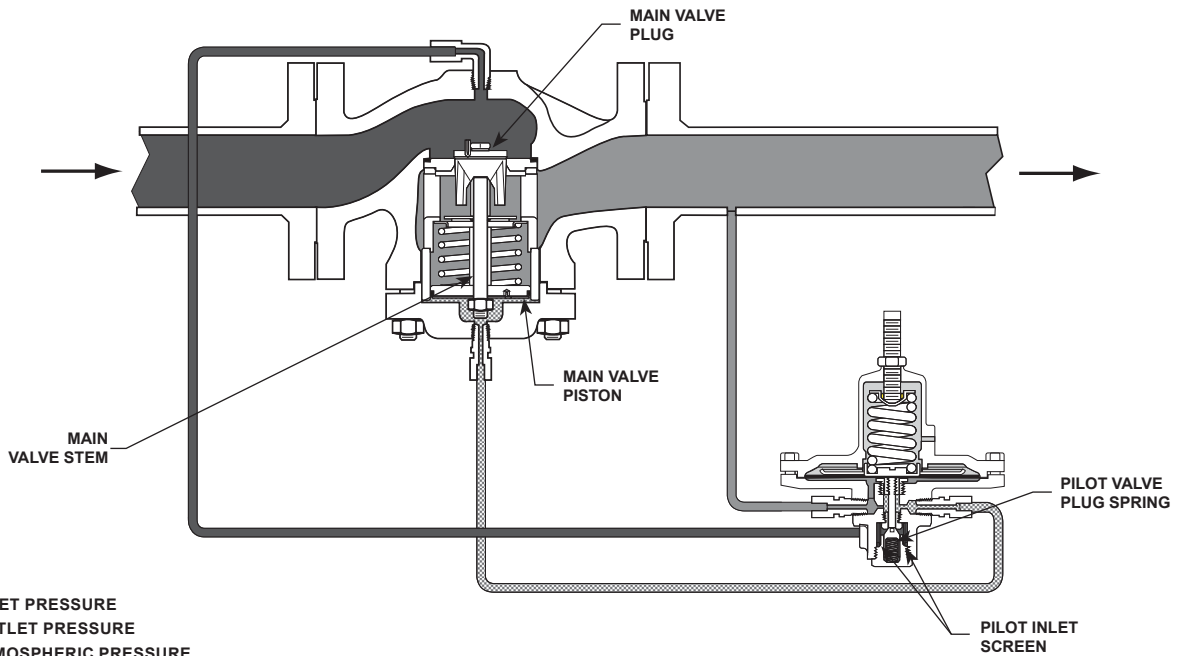

A6553

NPS 2-1/2, 3, 4 OR 6 x 4 / DN 65, 80, 100 OR 150 x 100
MAIN VALVE BODY AND TYPE 6492L PILOT

Figure 2. Type 92S Pressure Reducing Regulator Operational Schematics

Type 92S

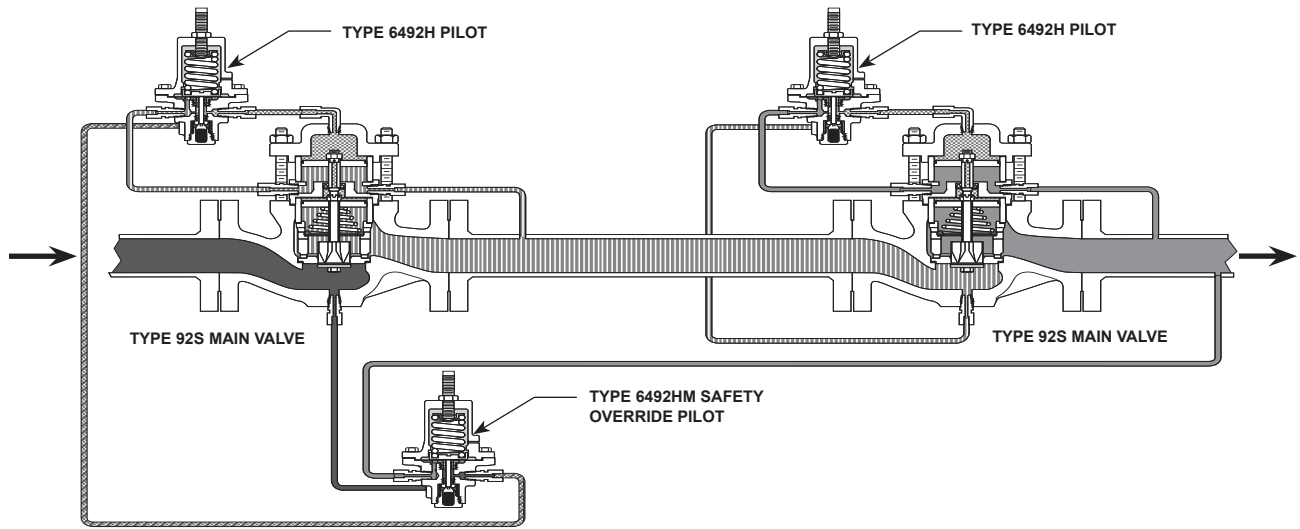

E0402

Figure 3. NPS 1, 1-1/2 and 2 / DN 25, 40 and 50 Type 92S Pilot-Operated Pressure Reducing Regulator with Safety Override Pilot Operational Schematic

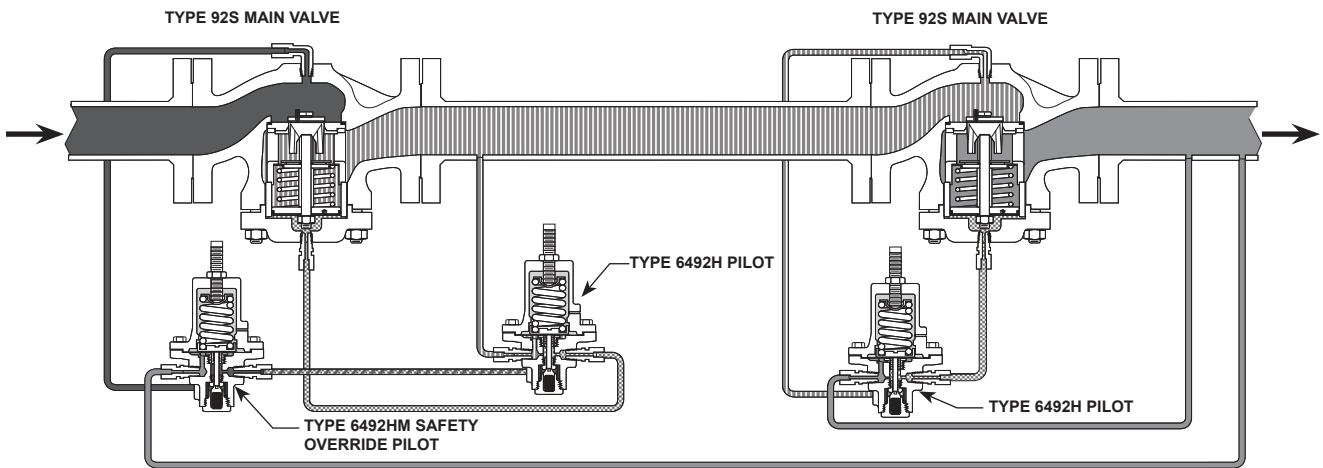

E0403

- INLET PRESSURE
- OUTLET PRESSURE
- ATMOSPHERIC PRESSURE
- LOADING PRESSURE
- INTERMEDIATE PRESSURE

Figure 4. NPS 2-1/2, 3 and 4 / DN 65, 80 and 100 Type 92S Pilot-Operated Pressure Reducing Valve with Safety Override Pilot Operational Schematic

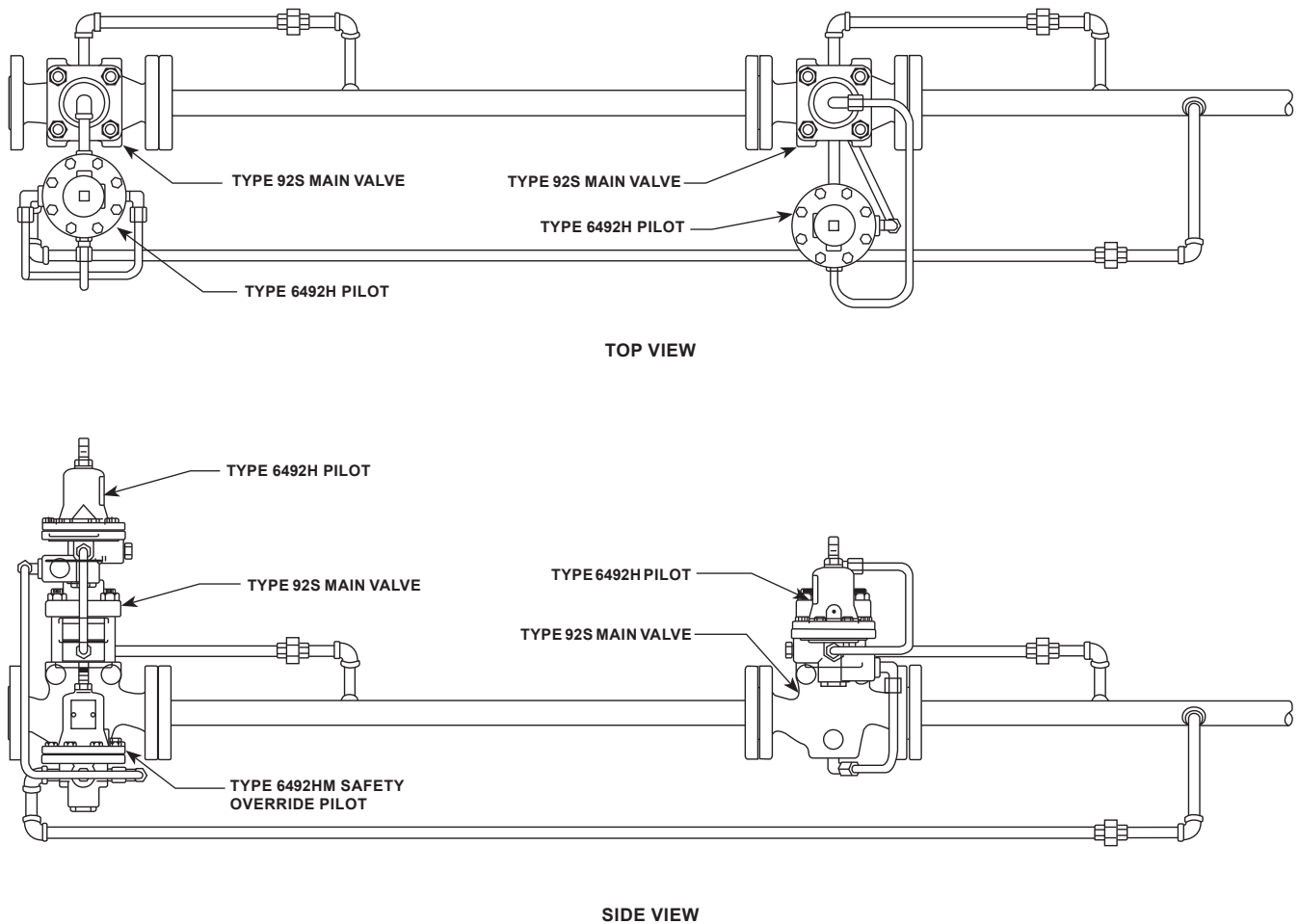

Figure 5. NPS 1, 1-1/2 and 2 / DN 25, 40 and 50 Piping Schematics

Table 4. Safety Pilot Outlet (Control) Pressure Ranges

TYPE	SPRING RANGE		SPRINGCOLOR	PART NUMBER	MINIMUM PRESSURE AT WHICH MONITORING PILOT CAN BE SET
	psig	bar			
6492HM	10 to 30	0.69 to 2.1	Yellow	1E395627022	5 psig / 0.35 bar over normal distribution pressure 10 psig / 0.69 bar over normal distribution pressure
	25 to 75	1.7 to 5.2	Green	1D7455T0012	
	70 to 150	4.8 to 10.3	Black	1E395727192	
6492HTM	15 to 100	1.0 to 6.9	Unpainted	14B9943X012	
	80 to 250	5.5 to 17.2		14B9942X012	

Type 92S

Type 92S Pilot-Operated Pressure Reducing Regulator with Safety Override Pilot

A Type 6492HM or 6492HTM safety override pilot is available for the Type 92S. The Type 6492H pilot is used in a series installation with the Type 6492HM or 6492HTM safety override pilot installed on the upstream regulator. The Type 6492HM or 6492HTM safety override pilot senses pressure downstream of the second valve and prevents pressure from rising above safe operating pressure in the event the downstream valve fails. This system is approved by ASME B31.1-1989, 122.14.2.A and can replace an ASME safety valve when vent piping is not practical and Type 92S Pilot-Operated, Pressure Reducing Regulator with Safety Override Pilot upstream steam pressure does not exceed 400 psig / 27.6 bar. Local codes and standards may require approval by an appropriate authority prior to installation.

Operation

Once placed in operation, the upstream Type 6492H pilot senses the intermediate pressure between both valves and the Type 6492HM or 6492HTM pilot senses downstream pressure of the second valve. As demand for flow increases, intermediate pressure will fall causing the Type 6492H pilot to open. As the Type 6492H pilot valve opens, loading pressure to the main valve increases, opening the main valve.

The Type 6492HM or 6492HTM safety override pilot remains open because its setpoint is above the setpoint of the downstream valve. In the unlikely event that the downstream valve fails open, downstream pressure will rise above the downstream valve's setpoint. This pressure is sensed by the Type 6492HM or 6492HTM safety override pilot. As downstream pressure increases the safety override pilot closes, reducing loading pressure to the main valve, which positions the main valve to maintain downstream pressure as specified per ASME Boiler and Pressure Vessel Code, Section VIII.

In the event that the upstream valve fails, the downstream regulator will prevent downstream pressure from rising above safe operating levels. It is recommended to install some type of warning system, such as a sentinel relief valve, to warn the operator that a valve has failed in the system. This will prevent prolonged operation with one valve, which could cause valve trim wear and noise associated with operation at high differential pressures.

When operating in most steam systems, valve setpoints should be in strict accordance to ASME Boiler and Pressure Vessel Code, Section VIII. The Type 6492HM or 6492HTM safety override pilot should be set at 10 psig / 0.69 bar or 10% above maximum downstream operating pressure of the second valve, whichever pressure is greater. For example, most HVAC systems operate at 15 psig / 1.0 bar, so the safety override pilot should be set no higher than 25 psig / 1.7 bar.

Capacity Information

Table 5 gives typical regulating capacities in lbs/h / kg/h of saturated steam. Capacities for regulators with noise attenuation trim are the same as for regulators without noise attenuation trim. Figure 8 shows a typical performance curve.

To determine regulating capacities at pressure settings not given in Table 5 or to determine wide-open capacities for relief sizing at any inlet pressure, use the following procedure 1 or 2 as appropriate.

1. If the steam is saturated and the pressure drop across the regulator is critical (absolute outlet pressure is equal to approximately one-half or less than one-half of the absolute inlet pressure), use the equation:

$$Q = (P_{1abs}) (C_s)$$

where,

- Q = Flow capacity in pounds of saturated steam per hour
 - P_{1abs} = Absolute inlet pressure in psia ($P_{1gauge} + 14.7$)
 - C_s = Regulating or wide-open steam sizing coefficient (see Table 3)
2. If the steam is superheated or if the pressure drop across the regulator is lower than critical (absolute outlet pressure is greater than approximately one-half the absolute inlet pressure), use the valve sizing slide rule or the sizing nomographs in Catalog 10.

Noise Abatement Information

A noise attenuation trim is available for use with NPS 2 / DN 50 and larger Type 92S steam regulators to provide an economical means for the reduction of noise from high-velocity steam flow. Capacities for a regulator equipped with a noise attenuation trim are the same as for a regulator without noise attenuation trim and are given in Table 5.

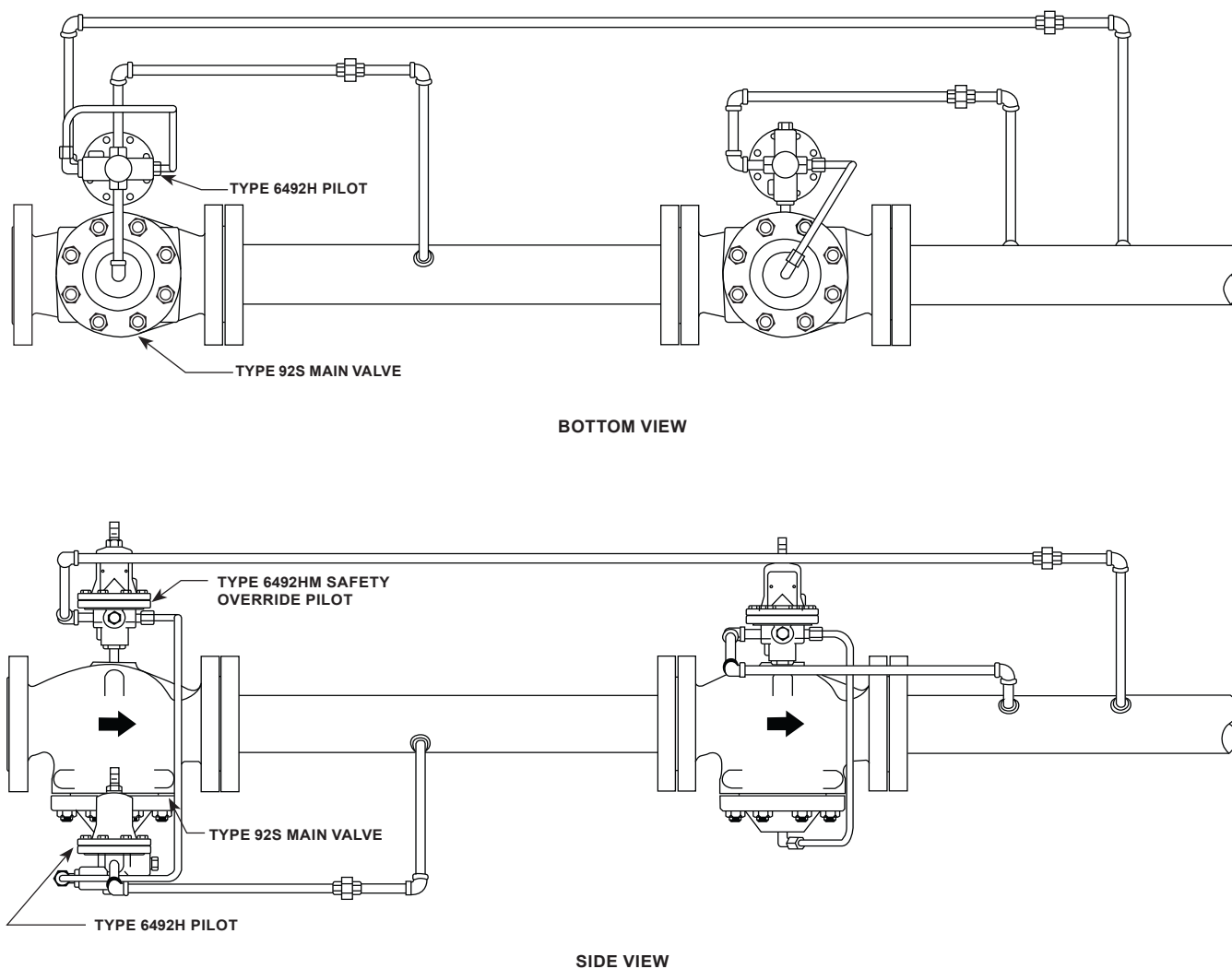

Figure 6. NPS 2-1/2, 3 and 4 / DN 65, 80 and 100 Piping Schematics

Noise level values for a regulator equipped either with or without a noise attenuation trim are presented in Table 6. These noise levels are determined at a point 39 in. / 991 mm downstream of the regulator outlet and 39 in. / 991 mm from the piping surface.

For example, consider full-capacity flow of steam through a NPS 2 / DN 50 Type 92S steam regulator connected with uninsulated 2 in. / 51 mm Schedule 40 downstream piping (see Table 6). For an inlet pressure of 250 psig / 17.2 bar and an outlet pressure of 100 psig / 6.9 bar, P/P_{1abs} is 0.6. Under the specified service conditions, the noise level for steam flow through a Type 92S steam regulator without a noise

attenuation trim will be 98 decibels, while the same regulator equipped with a noise attenuation trim will have a noise level reduced to 92 decibels.

Noise levels for steam flow through a Type 92S steam regulator can be reduced further with the use of either a heavier schedule of pipe or thermal insulation of the downstream piping. By using thermal insulation, as much as 15 decibels of noise can be additionally reduced from the system. Consult the insulation manufacturer's specifications for the attenuating capability and application procedures of the specific insulation required by your system.

Type 92S

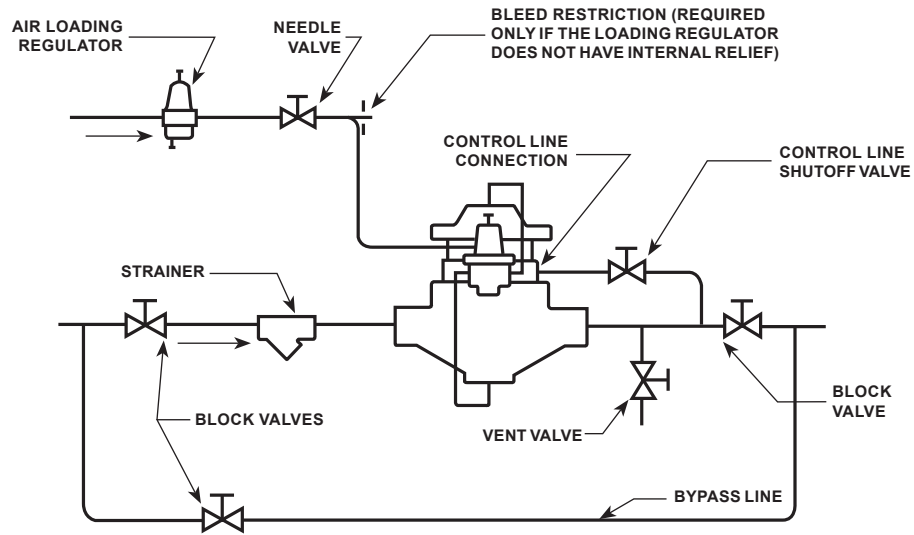

16A7958-B
16A1547-A
A3334

Figure 7. Typical Pressure-Loaded Pilot Installation

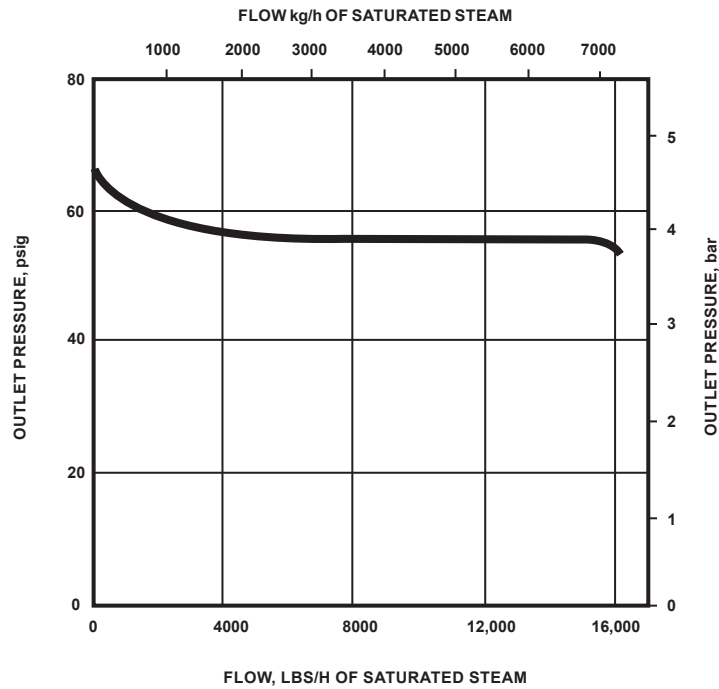

A3330/IL

NOTE:
INITIAL OUTLET PRESSURE SETTING IS 60 psig / 4.1 bar

Figure 8. Typical Performance Curve for NPS 2-1/2 / DN 65 Type 92S Pressure Reducing Regulator with Type 6492H Pilot

Table 5. Flow Capacities in Lbs/h / kg/h of Saturated Steam

OUTLET PRESSURE SETTING ⁽¹⁾		PILOT TYPE NUMBER	INLET PRESSURE		MAIN VALVE BODY SIZE, NPS / DN														DROOP
					1 / 25		1-1/2 / 40		2 / 50		2-1/2 / 65		3 / 80		4 / 100		6 x 4 / 150 x 100		
psig	bar		psig	bar	lbs/h	kg/h	lbs/h	kg/h	lbs/h	kg/h	lbs/h	kg/h	lbs/h	kg/h	lbs/h	kg/h	lbs/h	kg/h	
5	0.35	6492L	25	1.7	575	261	950	431	1750	794	1000	454	1225	556	2510	1139	2600	1179	1 psi / 0.07 bar
			30	2.1	700	318	1150	522	1880	853	1500	680	2200	998	4000	1814	4100	1860	
			50	3.5	950	431	1800	816	2950	1338	4180	1896	6550	2971	8500	3856	8600	3901	
10	0.69	6492H or 6492L	75	5.2	1350	612	2375	1077	4100	1860	6000	2722	8400	3810	12,600	5715	12,900	5851	10% of outlet pressure setting
			100	6.9	1725	782	3050	1383	5600	2540	8500	3856	10,300	4672	14,300	6486	15,100	6849	
			150	10.3	1800	816	4050	1837	6150	2790	11,900	5398	16,900	7666	23,000	10433	23,600	10,705	
15	1.0	6492L, 6492H or 6492HT	30	2.1	700	318	1200	544	2050	930	3050	1383	4300	1950	5800	2631	5800	2631	10% of outlet pressure setting
			50	3.5	1040	472	1800	816	3100	1406	4700	2132	6250	2835	8920	4046	9200	4173	
			75	5.2	1440	653	2600	1179	4400	1996	6000	2722	9000	4082	11,000	4990	11,500	5216	
20	1.4	6492L, 6492H or 6492HT	100	6.9	1800	816	3300	1497	5600	2540	8600	3901	10,700	4854	16,300	7394	17,100	7757	10% of outlet pressure setting
			150	10.3	2350	1066	4500	2041	8000	3629	12,000	5443	17,000	7711	19,600	8891	20,200	9163	
			200	13.8	2150	975	5100	2313	9200	4173									
30	2.1	6492H, 6492HT	35	2.4	710	322	1300	590	2100	953	2300	1043	3200	1452	4600	2087	4600	2087	10% of outlet pressure setting
			50	3.5	1040	472	1800	816	2950	1338	4550	2064	6200	2812	7700	3493	8100	3674	
			75	5.2	1440	653	2650	1202	4300	1950	6300	2858	8900	4037	11,900	5398	12,200	5534	
40	2.8	6492H, 6492HT	100	6.9	1820	826	3400	1542	5450	2472	8100	3674	11,800	5352	16,100	7303	16,800	7620	10% of outlet pressure setting
			150	10.3	2600	1179	4800	2177	7800	3538	12,100	5489	16,900	7666	23,100	10,478	23,800	10,796	
			200	13.8	3400	1542	6200	2812	10,200	4627									
50	3.5	6492H, 6492HT	50	3.5	1040	472	1800	816	2950	1338	4590	2082	6250	2835	7570	3434	7700	3493	10% of outlet pressure setting
			75	5.2	1440	653	2700	1225	4300	1950	6450	2926	9100	4128	11,000	4990	11,800	5352	
			100	6.9	1820	826	3450	1565	5450	2472	8650	3924	11,900	5398	16,200	7348	16,900	7666	
60	4.1	6492H, 6492HT	150	10.3	2650	1202	4900	2223	7950	3606	12,300	5579	17,150	7779	23,500	10,660	24,100	10,932	10% of outlet pressure setting
			200	13.8	3450	1565	6400	2903	10,300	4672									
			250	17.2	4300	1950	8000	3629	12,900	5851									
80	5.5	6492H, 6492HT	50	3.5	900	408	1650	748	2700	1225	4040	1833	5350	2427	7770	3524	8100	3674	10% of outlet pressure setting
			75	5.2	1440	653	2700	1225	4300	1950	6580	2985	8800	3992	12,000	5443	12,500	5670	
			100	6.9	1820	826	3450	1565	5450	2472	8400	3810	11,800	5352	19,000	8618	19,600	8891	
100	6.9	6492H, 6492HT	150	10.3	2650	1202	4900	2223	7950	3606	12,000	5443	17,000	7711	23,100	10,478	23,800	10,796	10% of outlet pressure setting
			200	13.8	3450	1565	6500	2948	10,000	4536	15,700	7122	22,100	10,025	30,100	13,653	30,600	13,880	
			250	17.2	4300	1950	8000	3629	12,900	5851									
100	6.9	6492H, 6492HT	60	4.1	1100	499	1750	794	3300	1497	4500	2041	6400	2903	8800	3992	9000	4082	10% of outlet pressure setting
			75	5.2	1440	653	2500	1134	4300	1950	6300	2858	8350	3788	11,300	5126	11,900	5398	
			100	6.9	1820	826	3450	1565	5450	2472	8500	3856	11,400	5171	15,300	6940	16,100	7303	
100	6.9	6492H, 6492HT	150	10.3	2650	1202	4900	2223	7950	3606	12,600	5715	17,000	7711	23,000	10,433	24,000	10,886	10% of outlet pressure setting
			200	13.8	3450	1565	6500	2948	10,300	4672	16,400	7439	22,450	10,183	30,200	13,699	31,000	14,062	
			250	17.2	4300	1950	8000	3629	12,900	5851									
100	6.9	6492H, 6492HT	100	6.9	1450	658	2600	1179	4350	1973	6270	2844	9250	4196	11,900	5398	12,300	5579	10% of outlet pressure setting
			150	10.3	2600	1179	4650	2109	7800	3538	11,700	5307	15,850	7190	21,400	9707	22,000	9979	
			200	13.8	3450	1565	6500	2948	10,300	4672	15,600	7076	21,750	9866	29,600	13,427	30,200	13,699	
100	6.9	6492H, 6492HT	250	17.2	4300	1950	8000	3629	12,900	5851	19,300	8754	27,750	12,587	38,000	17,237	39,000	17,690	10% of outlet pressure setting
			125	8.6	1900	862	3300	1497	5700	2586	8470	3842	11,400	5171	14,400	6532	15,200	6895	
			150	10.3	2490	1129	4350	1973	7450	3379	11,000	4990	14,900	6759	19,900	9027	20,500	9299	
100	6.9	6492H, 6492HT	200	13.8	3450	1565	6250	2835	10,300	4672	15,700	7122	21,350	9684	28,700	13,018	29,100	13,200	10% of outlet pressure setting
			250	17.2	4300	1950	8000	3629	12,900	5851	20,100	9117	26,800	12,156	35,700	16,194	36,500	16,556	
			300	20.7	5050	2291	9400	4264	15,100	6849									

Shaded areas show where maximum differential pressure is exceeded.
 1. Standard pilot or combination of setting plus loading pressure or optional pilot.

- continued -

Type 92S

Table 5. Flow Capacities in Lbs/h / kg/h of Saturated Steam (continued)

OUTLET PRESSURE SETTING ⁽¹⁾		PILOT TYPE NUMBER	INLET PRESSURE		MAIN VALVE BODY SIZE, NPS / DN														DROOP	
					1 / 25		1-1/2 / 40		2 / 50		2-1/2 / 65		3 / 80		4 / 100		6 x 4 / 150 x 100			
psig	bar		psig	bar	lbs/h	kg/h	lbs/h	kg/h	lbs/h	kg/h	lbs/h	kg/h	lbs/h	kg/h	lbs/h	kg/h	lbs/h	kg/h		
125	8.6	6492H, 6492HT	140	9.7	1600	726	3100	1406	4800	2177										10% of outlet pressure setting
			150	10.3	1900	862	3650	1656	5700	2586	9200	4173	13,100	5942	16,400	7439	16,900	7666		
			200	13.8	3150	1429	5750	2608	9450	4287	14,600	6623	19,950	9049	27,000	12,247	28,000	12,701		
			250	17.2	4300	1950	8000	3629	12,900	5851	19,500	8845	27,000	12,247	37,500	17,010	38,300	17,373		
			300	20.7	5050	2291	9400	4264	15,100	6849	23,800	10,796	32,500	14,742	44,300	20,094	45,100	20,457		
150	10.3	6492H, 6492HT	175	12.1	2450	1111	4000	1814	7300	3311	10,000	4536	14,000	6350	19,100	8664	20,100	9117		
			200	13.8	3050	1383	5250	2381	9100	4128	13,400	6078	18,200	8256	30,800	13,971	31,000	14,062		
			250	17.2	4150	1882	7400	3357	12,400	5625	18,600	8437	25,750	11,680	34,100	15,468	35,200	15,967		
			300	20.7	5050	2291	9400	4264	15,100	6849	23,400	10,614	31,900	14,470	42,900	19,459	43,300	19,641		

- Shaded areas indicate where minimum differential pressure is not attained.
 1. Standard pilot or combination of setting plus loading pressure or optional pilot.

Table 6. Noise Level Data in Decibels with Schedule 40 Downstream Piping and No Insulation⁽¹⁾

P ₁		$\frac{\Delta P}{P_{1abs}}$	PERCENTAGE OF MAXIMUM REGULATOR FLOW RATE	NOISE LEVEL, dBA								
				NPS 2 / DN 50 Main Valve Body with 2 in. / 51 mm Downstream Piping		NPS 2-1/2 / DN 65 Main Valve Body with 4 in. / 102 mm Downstream Piping		NPS 3 / DN 80 Main Valve Body with 4 in. / 102 mm Downstream Piping		NPS 4 / DN 100 Main Valve Body with 8 in. / 203 mm Downstream Piping		
psig	bar			Without Attenuator	With Attenuator	Without Attenuator	With Attenuator	Without Attenuator	With Attenuator	Without Attenuator	With Attenuator	
50	3.5	0.2	100	73	72	66	64	72	68	78	76	
			30	62	61	59	56	63	60	71	68	
			0.3	100	79	77	72	68	78	72	83	78
				30	68	66	61	57	65	61	73	70
			0.4	100	82	79	76	69	80	74	86	81
				30	71	68	65	61	69	65	76	73
0.5	100	84	80	78	72	82	76	88	83			
	30	73	69	67	63	73	67	79	75			
0.6	100	87	80	81	75	82	79	90	84			
	30	76	70	70	65	74	68	80	76			
0.7	100	88	82	84	79	88	83	92	87			
	30	78	71	73	69	80	71	83	79			
100	6.9	0.2	100	78	77	71	69	77	73	83	81	
			30	67	66	64	61	68	65	76	73	
		0.3	100	84	82	77	73	83	77	88	83	
			30	73	71	66	62	70	66	78	75	
		0.4	100	86	84	81	74	85	79	91	86	
			30	76	72	70	66	74	70	80	78	
0.5	100	89	85	83	77	87	81	93	88			
	30	78	74	72	68	78	72	84	80			
0.6	100	92	86	86	80	87	84	95	89			
	30	81	75	75	70	79	73	85	81			
0.7	100	82	75	78	74	85	76	88	84			
	30	93	86	89	84	93	88	97	92			

1. Overall noise levels determined at a point 39 in. / 991 mm downstream of the regulator outlet and 39 in. / 991 mm from piping surface.

- continued -

Table 6. Noise Level Data in Decibels with Schedule 40 Downstream Piping and No Insulation⁽¹⁾(continued)

P ₁		$\frac{\Delta P}{P_{\text{fabs}}}$	PERCENTAGE OF MAXIMUM REGULATOR FLOW RATE	NOISE LEVEL, dBA							
				NPS 2 / DN 50 Main Valve Body with 2 in. / 51 mm Downstream Piping		NPS 2-1/2 / DN 65 Main Valve Body with 4 in. / 102 mm Downstream Piping		NPS 3 / DN 80 Main Valve Body with 4 in. / 102 mm Downstream Piping		NPS 4 / DN 100 Main Valve Body with 8 in. / 203 mm Downstream Piping	
psig	bar			Without Attenuator	With Attenuator	Without Attenuator	With Attenuator	Without Attenuator	With Attenuator	Without Attenuator	With Attenuator
250	17.2	0.2	100 30	84 73	81 71	78 71	76 68	84 75	80 72	90 83	88 80
		0.3	100 30	90 80	85 77	84 73	80 69	90 77	84 73	95 85	90 82
		0.4	100 30	93 82	88 78	88 77	81 73	92 81	86 77	98 88	93 85
		0.5	100 30	95 85	91 80	90 79	84 75	94 85	88 79	100 91	95 87
		0.6	100 30	98 88	92 82	93 82	87 77	94 86	91 80	102 92	96 88
		0.7	100 30	101 89	94 83	96 85	91 81	100 92	95 83	104 95	99 91

1. Overall noise levels determined at a point 39 in. / 991 mm downstream of the regulator outlet and 39 in. / 991 mm from piping surface.

Ordering Information

When ordering, specify:

Application

- Range of temperatures
- Range of inlet pressures (maximum, normal, minimum)
- Outlet pressure setting
- Range of flow rates (maximum, normal, minimum, controlled)
- Body size

Construction

Refer to the Specifications section on page 2. Review the descriptions to the right of each specification and specify the desired choice wherever there is a selection to be made. If not otherwise specified, the pilot control spring is factory-set at the approximate mid-range.

Be sure to specify the type of regulator desired (standard pilot or pilot with optional tapped spring case). Refer to separate bulletins for information on loading regulators for use with pressure loaded pilots.

Type 92S

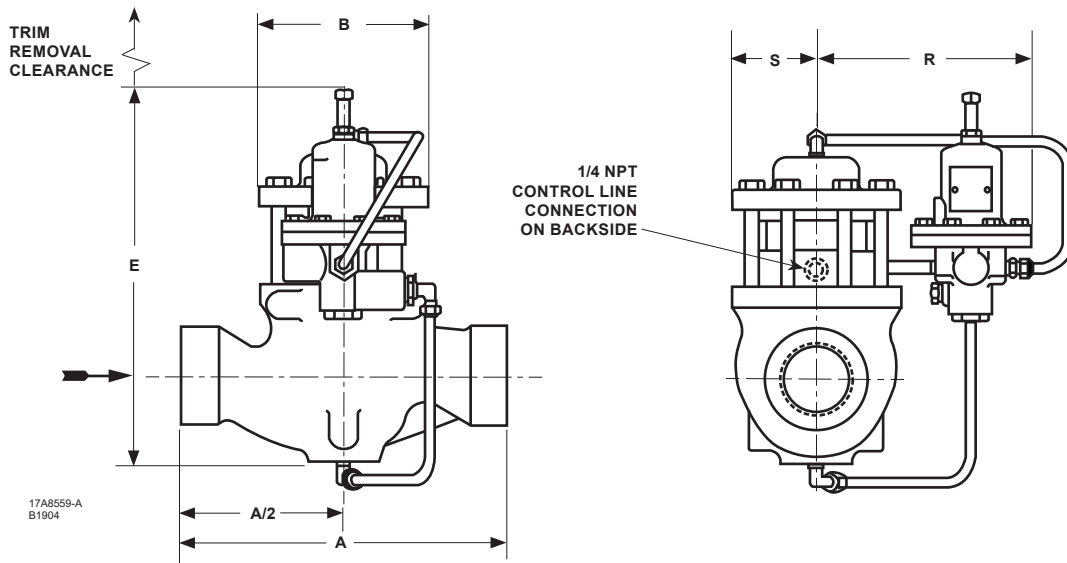

NPS 1, 1-1/2 OR 2 / DN 25, 40 OR 50 MAIN VALVE BODY

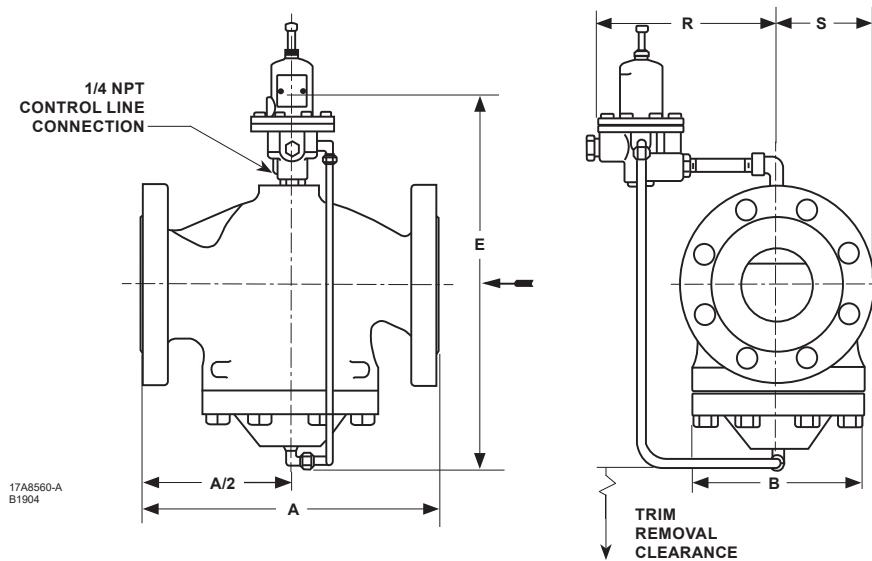

NPS 2-1/2, 3, 4 OR 6 x 4 / DN 65, 80, 100 OR 150 x 100 MAIN VALVE BODY

Figure 9. Dimensions

Table 7. Dimensions

MAIN VALVE BODY SIZE		DIMENSION																					
		A								B		E (Maximum)		R				S		Trim Removal Clearance			
		NPT		CL125 FF or CL150 RF Flanged		CL250 RF or CL300 RF Flanged		CL600 RF Flanged						Types 6492H and 6492HT Pilot		Type 6492L Pilot							
NPS	DN	In.	mm	In.	mm	In.	mm	In.	mm	In.	mm	In.	mm	In.	mm	In.	mm	In.	mm	In.	mm		
1	25	8.25	210	7.25	184	7.75	197	8.25	210	3.88	99	11.69	297	8.50	216	9.88	251	1.94	49				
1/2	40	9.88	251	8.75	222	9.25	235	9.88	251	5.38	137	12.19	310	8.81	224	10.19	259	2.69	68	2.75	70		
2	50	11.25	286	10.00	254	10.50	267	11.25	286	5.88	149	13.00	330	9.06	230	10.44	265	2.94	75				
2-1/2	65	----	----	10.88	276	11.50	292	12.25	311	6.56	167	17.19	437	8.75	222	10.12	257	3.28	83	3.12	79		
3	80	----	----	11.75	298	12.50	318	13.25	337	7.38	187	18.25	464	8.75	222	10.12	257	3.69	94	3.12	79		
4	100	----	----	13.88	353	14.50	368	15.50	394	8.62	219	20.44	519	10.38	264	11.75	298	4.31	109	5.00	127		
6 x 4	150 x 100	----	----	----	----	18.62	473	20.00	508	8.62	219	22.06	560	11.50	292	12.88	327	4.31	109	7.00	178		

Ordering Guide

Body Size (Select One)

- NPS 1 / DN 25**
- NPS 1-1/2 / DN 40**
- NPS 2 / DN 50***
- NPS 2-1/2 / DN 65*
- NPS 3 / DN 80**
- NPS 4 / DN 100**
- NPS 6 x 4 / DN 150 x 100
(WCC Steel or Stainless steel with CL300 RF and CL600 RF only)*

Body and Body Flange Material and End Connection Style (Select One)

Cast Iron

- NPT***
- CL125 FF**
- CL250 RF**

WCC Steel

- NPT***
- CL150 RF**
- CL300 RF**
- CL600 RF**
- PN 16/25/40**

CF8M Stainless Steel

- NPT**
- CL150 RF*
- CL300 RF*
- CL600 RF*
- PN 16/25/40*

Tubing and Fittings (Select One)

- Copper tubing with brass fittings***
- Stainless steel tubing and fittings**

Pilot Bellows (Select One)

- Brass (standard)***
- 321 Stainless steel**

Outlet Pressure Range (Select One)

Type 6492L Pilot

- 2 to 6 psig / 0.14 to 0.41 bar, Yellow***
- 5 to 15 psig / 0.35 to 1.0 bar, Green***
- 13 to 25 psig / 0.90 to 1.7 bar, Red***

Type 6492H Pilot

- 10 to 30 psig / 0.69 to 2.1 bar, Yellow***
- 25 to 75 psig / 1.7 to 5.2 bar, Green***
- 70 to 150 psig / 4.8 to 10.3 bar, Red***

Type 6492HT Pilot

- 15 to 100 psig / 1.0 to 6.9 bar, Unpainted***
- 80 to 250 psig / 5.5 to 17.2 bar, Unpainted***

Noise Attenuation Trim (Optional)

- Yes**

Replacement Pilot (Optional)

- Yes, send one replacement pilot to match this order.

Main Valve Replacement Parts Kit (Optional)

- Yes, send one main valve replacement parts kit to match this order.

Pilot Replacement Parts Kit (Optional)

- Yes, send one pilot replacement parts kit to match this order.

Regulators Quick Order Guide	
***	Readily Available for Shipment
**	Allow Additional Time for Shipment
*	Special Order, Constructed from Non-Stocked Parts. Consult Your local Sales Office for Availability.
Availability of the product being ordered is determined by the component with the longest shipping time for the requested construction.	

Steam Specification Worksheet

Application:
Tag Number: _____

Valve Type: Direct-Operated Pilot-Operated
 Pressure Loaded Differential

Body Material: Steel Iron Stainless steel

Inlet/Outlet End Connection Style:
 CL150 RF Flange NPT
 CL300 RF Flange CL250 RF Flange
 PN 16/25/40 CL600 RF Flange

Inlet/Outlet Pipe Size: _____ In. / mm

Steam Conditions:

	Maximum	Normal	Minimum
Inlet Pressure (psig/bar)			
Inlet Temperature (°F/°C)			
Outlet Pressure (psig/bar)			
Flow (lbs/h or kg/hr)			

Performance Required:
 Accuracy Requirements: ≤10% ≤20%
 ≤30% ≤40%

Type 92S

✉ Webadmin.Regulators@emerson.com

🔍 Fisher.com

📘 Facebook.com/EmersonAutomationSolutions

🌐 LinkedIn.com/company/emerson-automation-solutions

🐦 Twitter.com/emr_automation

Emerson Automation Solutions

Americas

McKinney, Texas 75070 USA
T +1 800 558 5853
+1 972 548 3574

Europe

Bologna 40013, Italy
T +39 051 419 0611

Asia Pacific

Singapore 128461, Singapore
T +65 6777 8211

Middle East and Africa

Dubai, United Arab Emirates
T +971 4 811 8100

D100621X012 © 1984, 2021 Emerson Process Management Regulator Technologies, Inc. All rights reserved. 04/21.

The Emerson logo is a trademark and service mark of Emerson Electric Co. All other marks are the property of their prospective owners. Fisher™ is a mark owned by Fisher Controls International LLC, a business of Emerson Automation Solutions.

The contents of this publication are presented for informational purposes only, and while every effort has been made to ensure their accuracy, they are not to be construed as warranties or guarantees, express or implied, regarding the products or services described herein or their use or applicability. All sales are governed by our terms and conditions, which are available upon request. We reserve the right to modify or improve the designs or specifications of such products at any time without notice.

Emerson Process Management Regulator Technologies, Inc does not assume responsibility for the selection, use or maintenance of any product. Responsibility for proper selection, use and maintenance of any Emerson Process Management Regulator Technologies, Inc. product remains solely with the purchaser.

