

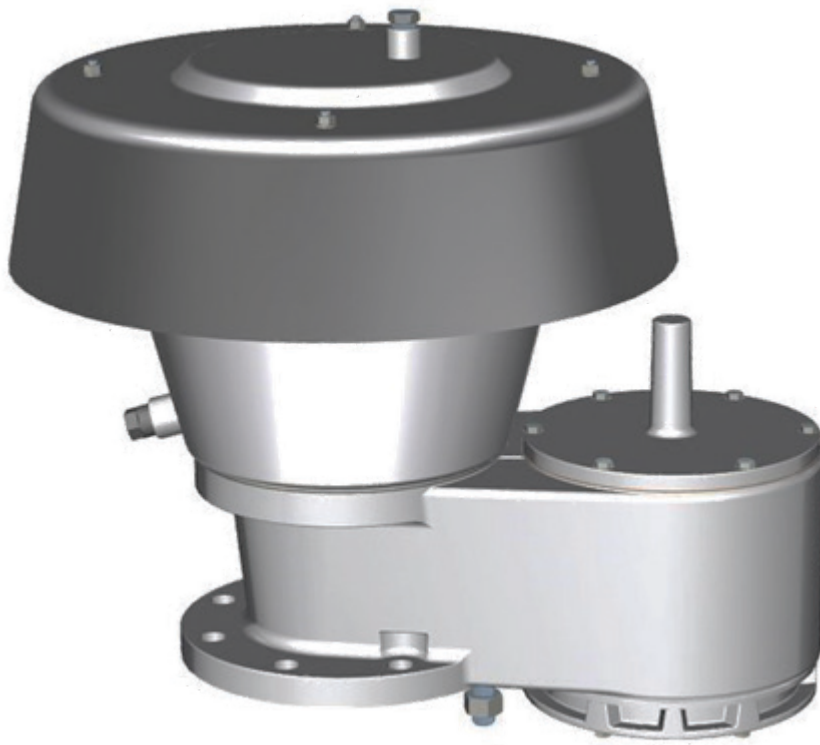

ANDERSON GREENWOOD 5910C PRESSURE VACUUM RELIEF VALVE WITH FLAME ARRESTER COMBINATION

Integrated solution to protect tanks from excess pressure and vacuum scenarios while also preventing explosion from external heat and ignition sources.



FEATURES

- Element and shroud optimized for flow efficiency
- Oversized pressure and vacuum ports provide maximum flow capacity
- Easily removed hood and elements for inspection and maintenance
- Replaceable and interchangeable pressure and vacuum seat rings
- Modular design allows for reduced number of spare parts required

GENERAL APPLICATION

The 5910C is a pressure and vacuum relief valve with integrated flame arrester, designed to protect above ground storage tanks containing potentially flammable liquids and vapors from rupture or explosion by over-pressure and from external heat and ignition sources. This integrated solution combines decades of proven flame arrester performance and tank venting experience into one combined unit that is light weight and easy to maintain.

TECHNICAL DATA

Materials:	Aluminum, carbon steel, stainless steel
Sizes:	2" to 8" (DN 50 to 200)
Connections:	Drilled flange
Settings:	up to 1 psig (69 mbar)
Temperature Range:	-20 to 60°C (-4 to 140°F)
Gas Groups:	IEC Classification IIA and IIB3
Certification:	ISO 16852

ANDERSON GREENWOOD 5910C PRESSURE VACUUM RELIEF VALVE WITH FLAME ARRESTER COMBINATION

MODELS OVERVIEW

The 5910C Series Relief Valves protect tanks from excessive pressure and vacuum, maintaining system operating pressure so vapor is not vented to the atmosphere routinely.

The flame arrester protects the tank from accidental ignition of vapor within the tank. It is designed to stop the propagation of flame from external sources.

OPERATION

Whenever the tank pressure or vacuum exceeds the setting, the pallet lifts. Only excess pressure is vented to the atmosphere. Air is drawn into the tank only to relieve an excess vacuum condition. The valve remains closed when the vapor space remains within normal operating pressure.

The valve pallets are deadweight loaded with a field adjustable pressure setting range. Side and center pallet guides are incorporated for stability. 'Air cushion' PTFE seat inserts ensure a tighter seal and can be replaced easily.

If H₂S corrosion is a concern, supplying the relief valve with 316 SS trim is an option. The flame arrester bank is also available in 316 SS.

The flame arrester helps stop the propagation of a flame by absorbing and dissipating heat through the surface area of the Element. Heat is absorbed as ignited gas attempts to pass through the small passages within the Element assembly. This action lowers the temperature of the gas below its ignition point and quenches the flame.

The element assembly can be inspected easily and cleaned to remove any dirt or residue build-up

SPECIFICATIONS

The 5910C Pressure and Vacuum Relief Valves are available in a variety of configurations to meet your specific needs.

Sizes

- 2" (DN 50)
- 3" (DN 80)
- 4" (DN 100)
- 6" (DN 150)
- 8" (DN 200)

Connections

- Aluminum
 - Drilled to ANSI Class 150 dimensions (flat face)
 - Drilled to DIN 2633 (16 bar) dimensions (flat face)
- CS and SS body
 - Drilled to ANSI Class 150 dimensions (raised or flat face)
 - Drilled to imperial DIN 2633 (16 bar) dimensions (raised or flat face)

Mounting studs

- Fractional (imperial) ANSI 150
- Metric DIN 2633

Settings

Pressure and Vacuum settings available as per Table 1

Testing

Each valve is tested for proper setting and for a leakage rate of less than 1 SCFH (0.03 Nm³/hr) of air at 90 percent of the set point. Each valve is tested for leak tightness at 75 percent of set point as required in API Standard 2000.

Flame Arrester standard specification

Each unit comes equipped with two Flame Arresting Elements. The elements are approved for service in accordance with ISO16852 for Gas Group IIA and IIB3.

ANDERSON GREENWOOD 5910C PRESSURE VACUUM RELIEF VALVE WITH FLAME ARRESTER COMBINATION

TABLE 1.

Size	Body/Trim code	Body/Trim Material	Pressure oz/in ² (mbar)		Vacuum oz/in ² (mbar)	
			Min	Max	Min	Max
2	1	Aluminum (Al) / Aluminum (Al)	0.29 (1.25)	16 (69)	0.26 (1.12)	10 (43)
	2	Aluminum / 316 Stainless Steel (SST)	0.70 (3.0)	16 (69)	0.62 (2.67)	10 (43)
	3	Carbon Steel (CS) / 316 Stainless Steel (SST)	0.70 (3.0)	16 (69)	0.62 (2.67)	10 (43)
	4	316 Stainless Steel (SST) / 316 Stainless Steel (SST)	0.70 (3.0)	16 (69)	0.62 (2.67)	10 (43)
	7	CS / SST / PTFE ctd Al Vacuum	0.70 (3.0)	16 (69)	0.62 (2.67)	10 (43)
	8	SST / SST Pressure / PTFE ctd Al Vacuum	0.70 (3.0)	16 (69)	0.26 (1.12)	10 (43)
3	1	Aluminum (Al) / Aluminum (Al)	0.23 (0.99)	16 (69)	0.21 (0.90)	10 (43)
	2	Aluminum / 316 Stainless Steel (SST)	0.55 (2.37)	16 (69)	0.49 (2.11)	10 (43)
	3	Carbon Steel (CS) / 316 Stainless Steel (SST)	0.55 (2.37)	16 (69)	0.49 (2.11)	10 (43)
	4	316 Stainless Steel (SST) / 316 Stainless Steel (SST)	0.55 (2.37)	16 (69)	0.49 (2.11)	10 (43)
	7	CS / SST / PTFE ctd Al Vacuum	0.55 (2.37)	16 (69)	0.21 (0.90)	10 (43)
	8	SST / SST Pressure / PTFE ctd Al Vacuum	0.55 (2.37)	16 (69)	0.21 (0.90)	10 (43)
4	1	Aluminum (Al) / Aluminum (Al)	0.29 (1.25)	16 (69)	0.27 (1.16)	16 (69)
	2	Aluminum / 316 Stainless Steel (SST)	0.60 (2.59)	16 (69)	0.56 (2.41)	16 (69)
	3	Carbon Steel (CS) / 316 Stainless Steel (SST)	0.60 (2.59)	16 (69)	0.56 (2.41)	16 (69)
	4	316 Stainless Steel (SST) / 316 Stainless Steel (SST)	0.60 (2.59)	16 (69)	0.56 (2.41)	16 (69)
	7	CS / SST / PTFE ctd Al Vacuum	0.60 (2.59)	16 (69)	0.27 (1.16)	16 (69)
	8	SST / SST Pressure / PTFE ctd Al Vacuum	0.60 (2.59)	16 (69)	0.27 (1.16)	16 (69)
6	1	Aluminum (Al) / Aluminum (Al)	0.26 (1.12)	16 (69)	0.26 (1.12)	16 (69)
	2	Aluminum / 316 Stainless Steel (SST)	0.61 (2.63)	16 (69)	0.61 (2.63)	16 (69)
	3	Carbon Steel (CS) / 316 Stainless Steel (SST)	0.61 (2.63)	16 (69)	0.61 (2.63)	16 (69)
	4	316 Stainless Steel (SST) / 316 Stainless Steel (SST)	0.61 (2.63)	16 (69)	0.61 (2.63)	16 (69)
	7	CS / SST / PTFE ctd Al Vacuum	0.61 (2.63)	16 (69)	0.26 (1.12)	16 (69)
	8	SST / SST Pressure / PTFE ctd Al Vacuum	0.61 (2.63)	16 (69)	0.26 (1.12)	16 (69)
8	1	Aluminum (Al) / Aluminum (Al)	0.25 (1.08)	16 (69)	0.25 (1.08)	16 (69)
	2	Aluminum / 316 Stainless Steel (SST)	0.55 (2.37)	16 (69)	0.55 (2.37)	16 (69)
	3	Carbon Steel (CS) / 316 Stainless Steel (SST)	0.55 (2.37)	16 (69)	0.55 (2.37)	16 (69)
	4	316 Stainless Steel (SST) / 316 Stainless Steel (SST)	0.55 (2.37)	16 (69)	0.55 (2.37)	16 (69)
	7	CS / SST / PTFE ctd Al Vacuum	0.55 (2.37)	16 (69)	0.25 (1.08)	16 (69)
	8	SST / SST Pressure / PTFE ctd Al Vacuum	0.55 (2.37)	16 (69)	0.25 (1.08)	16 (69)

Lower settings may be available. Please consult your sales representative.

All values are factory tested for leakage and correct setting prior to shipment.

Certification of valve setting is available upon request.

Stand setting weights are lead.

ANDERSON GREENWOOD 5910C PRESSURE VACUUM RELIEF VALVE WITH FLAME ARRESTER COMBINATION

PARTS AND MATERIALS

TABLE 2A

Item	Description	Material Code					
		1	2	3	4	7	8
1	Body	Aluminum	Aluminum	Carbon Steel	Stainless Steel	Carbon Steel	Stainless Steel
3	Seat Ring	Aluminum	316SS	316SS	316SS	316SS	316SS
4	Guide Post, Vacuum	316SS	316SS	316SS	316SS	316SS	316SS
5	Guide Post, Pressure	316SS	316SS	316SS	316SS	316SS	316SS
6	Guide Post, Pressure	316SS	316SS	316SS	316SS	316SS	316SS
7	Pallet Stem	Aluminum	Aluminum	316SS	316SS	316SS	316SS
8	Pallet	Aluminum	Aluminum	316SS	316SS	316SS/Aluminum	316SS/Aluminum
9A	Insert (FEP)	See options	See options	See options	See options	See options	See options
9B	Insert	See options	See options	See options	See options	See options	See options
10	Insert Retainer	Aluminum	Aluminum	316SS	316SS	316SS	316SS
13	Screen, Pressure	316SS	316SS	316SS	316SS	316SS	316SS
14	Hood Ⓞ	Aluminum	Aluminum	Carbon Steel	Stainless Steel	Carbon Steel	Stainless Steel
16	Cover	Aluminum	Aluminum	Carbon Steel	Stainless Steel	Carbon Steel	Stainless Steel
17	Gasket	See options	See options	See options	See options	See options	See options
19	Spacer, Ring	Stainless Steel	Stainless Steel	Stainless Steel	Stainless Steel	Stainless Steel	Stainless Steel
21	Name Plate	316SS	316SS	316SS	316SS	316SS	316SS
22	Warning Label	Fiber	Fiber	Fiber	Fiber	Fiber	Fiber
24	Grip Ring	316SS	316SS	316SS	316SS	316SS	316SS
25	Stud	Carbon Steel	Carbon Steel	Carbon Steel	Stainless Steel	Carbon Steel	Stainless Steel
26	Nut	Carbon Steel	Carbon Steel	Carbon Steel	Stainless Steel	Carbon Steel	Stainless Steel
28	Nut	Carbon Steel	Carbon Steel	Carbon Steel	Stainless Steel	Carbon Steel	Stainless Steel
30	Screw, Cap Hex	Stainless Steel	Stainless Steel	Stainless Steel	Stainless Steel	Stainless Steel	Stainless Steel
31	Screw, Cap Hex	Stainless Steel	Stainless Steel	Stainless Steel	Stainless Steel	Stainless Steel	Stainless Steel
34	Screw, Cap Hex	Stainless Steel	Stainless Steel	Stainless Steel	Stainless Steel	Stainless Steel	Stainless Steel
35	Pallet Stem	Aluminum	Aluminum	316SS	316SS	Aluminum	Aluminum
37	Insert Retainer	Aluminum	Aluminum	316SS	316SS	Aluminum	Aluminum
38	Pallet	Aluminum	Aluminum	316SS	316SS	Aluminum	Aluminum
39	O-Ring	See options	See options	See options	See options	See options	See options
40	Washer	Stainless Steel	Stainless Steel	Stainless Steel	Stainless Steel	Stainless Steel	Stainless Steel
42	Washer	Stainless Steel	Stainless Steel	Stainless Steel	Stainless Steel	Stainless Steel	Stainless Steel
43	Shroud	Aluminum	Aluminum	Carbon Steel	Stainless Steel	Carbon Steel	Stainless Steel
44	Drain	316SS	316SS	316SS	316SS	316SS	316SS
45	Standoff	316SS	316SS	316SS	316SS	316SS	316SS
46	Element Assembly, Pressure Ⓞ	See options	See options	See options	See options	See options	See options
47	Element Assembly, Vacuum Ⓞ	See options	See options	See options	See options	See options	See options
48	Gasket, Pressure	See options	See options	See options	See options	See options	See options
49	Gasket, Seat	See options	See options	See options	See options	See options	See options
50	Plug	316SS	316SS	316SS	316SS	316SS	316SS

ANDERSON GREENWOOD 5910C PRESSURE VACUUM RELIEF VALVE WITH FLAME ARRESTER COMBINATION

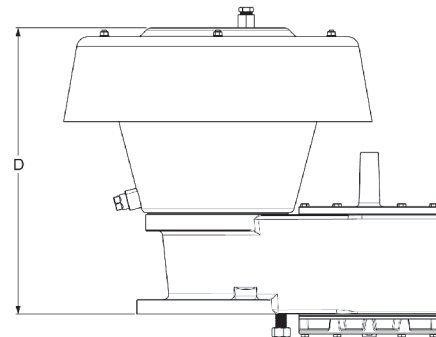
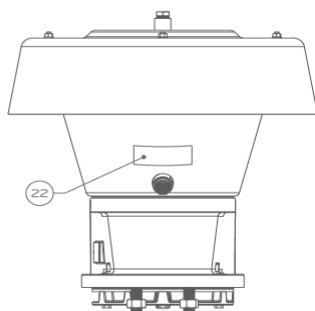
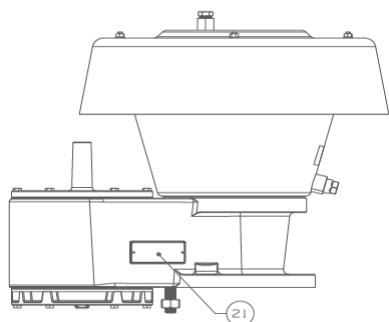
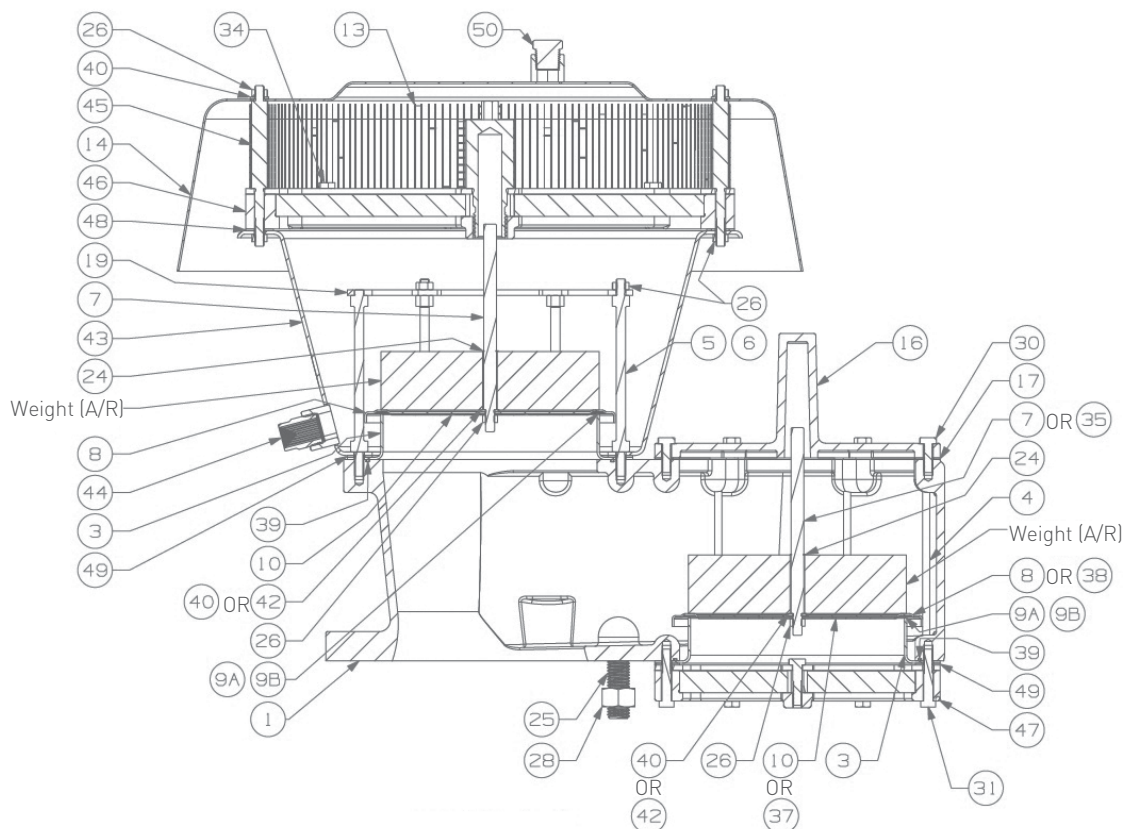

DIMENSIONS

Body Size	A (mm)	B (mm)	C (mm)	D* (mm)
2"	445	390	251	329
3"	505	390	311	360
4"	588	543	316	430
6"	666	543	395	503
8"	818	642	497	577

* Does not include coupling.

Body Size	A (in)	B (in)	C (in)	D* (in)
2"	17.52	15.35	9.88	12.95
3"	19.88	15.35	12.24	14.17
4"	23.15	21.38	12.44	16.93
6"	26.22	21.38	15.55	19.80
8"	32.20	25.28	19.57	22.72

* Does not include coupling.

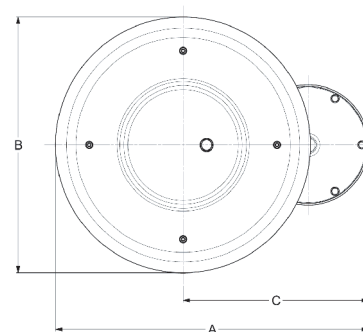

ANDERSON GREENWOOD 5910C PRESSURE VACUUM RELIEF VALVE WITH FLAME ARRESTER COMBINATION

SELECTION GUIDE

Example:	59	1	0C	3	4	T	FR	B	02	02	2	D	0	0
Model														
59	PVRV/FA Combo													
Model														
1	Vent-to-atmosphere													
Configuration														
0C	Standard Air Cushion Seat													
Size														
2	2" (DN 50)													
3	3" (DN 80)													
4	4" (DN 100)													
6	6" (DN 150)													
8	8" (DN 200)													
Body/Trim Material														
1	Aluminum/aluminum													
2	Aluminum/316 stainless steel													
3	Carbon steel/316 stainless steel													
4	316 stainless steel/316 stainless steel													
7	Carbon steel/316 stainless steel with PTFE Coated Aluminum Vacuum Pallet													
8	316 stainless steel/316 stainless steel with PTFE Coated Aluminum Vacuum Pallet													
Insert Material														
T	PTFE													
B	NBR													
V	FKM													
Flange Connection														
FF	Flat face flange drilled to ANSI 150 with fractional studs													
FR	Raised face flange drilled to ANSI 150 with fractional studs (not available on aluminum)													
DF	DIN flat face flange drilling													
DR	DIN raised face flange drilling (not available on aluminum)													
Gasket and O-Rings Material														
0	Standard Fiber/NBR													
T	PTFE													
B	NBR													
V	FKM													
Pressure Setting range														
02	Standard Setting Range (see figure 3)													
Vacuum Setting range														
02	Standard Setting Range (see figure 4)													
Element Housing Material														
1	Carbon Steel													
2	Stainless Steel													
Gas Group														
C	IEC Classification IIB3													
D	IEC Classification IIA													
Burn Type														
0	No Burn													
1	1 minute * (1 minute burn with Aluminum body will have Stainless Steel Weatherhood)													
Accessories														
0	None													

ANDERSON GREENWOOD 5910C PRESSURE VACUUM RELIEF VALVE WITH
FLAME ARRESTER COMBINATION

ANDERSON GREENWOOD 5910C PRESSURE VACUUM RELIEF VALVE WITH FLAME ARRESTER COMBINATION

VCTDS-16954-EN © 2021, 2022 Emerson Electric Co. All rights reserved 12/22. Anderson Greenwood is a mark owned by one of the companies in the Emerson Automation Solutions business unit of Emerson Electric Co. The Emerson logo is a trademark and service mark of Emerson Electric Co. All other marks are the property of their prospective owners.

The contents of this publication are presented for informational purposes only, and while every effort has been made to ensure their accuracy, they are not to be construed as warranties or guarantees, express or implied, regarding the products or services described herein or their use or applicability. All sales are governed by our terms and conditions, which are available upon request. We reserve the right to modify or improve the designs or specifications of such products at any time without notice.

Emerson Electric Co. does not assume responsibility for the selection, use or maintenance of any product. Responsibility for proper selection, use and maintenance of any Emerson Electric Co. product remains solely with the purchaser.

[Emerson.com](https://www.emerson.com)
