

SLAM-SHUT VALVES

Type BM5



TARTARINI™

EMERSON™

BM5 Slam-Shut Valves

Slam-shut valves

BM5 Series slam-shut valve is an automatic shut-off appliance suitable for installation as safety device in regulating stations and gas distribution piping.

The slam-shut valve has the task to quickly shut off the gas flow when the pressure in control point(s) reaches a fixed set value.

The valve is sleeve-type and as a consequence does not need any external by-pass to facilitate the opening of the valve itself.

The valve re-opening can be made only through a manual operation.

The main features are as follows:

- *Axial flow*
- *Flanged connections*
- *Protected seal pad*
- *Possible to fit in all positions*
- *Pressure control in one or more points of the installation*
- *Starting up following overpressure and/or underpressure*
- *Push-button manual emergency release*
- *Manual reset through rotation of the reset shaft only*

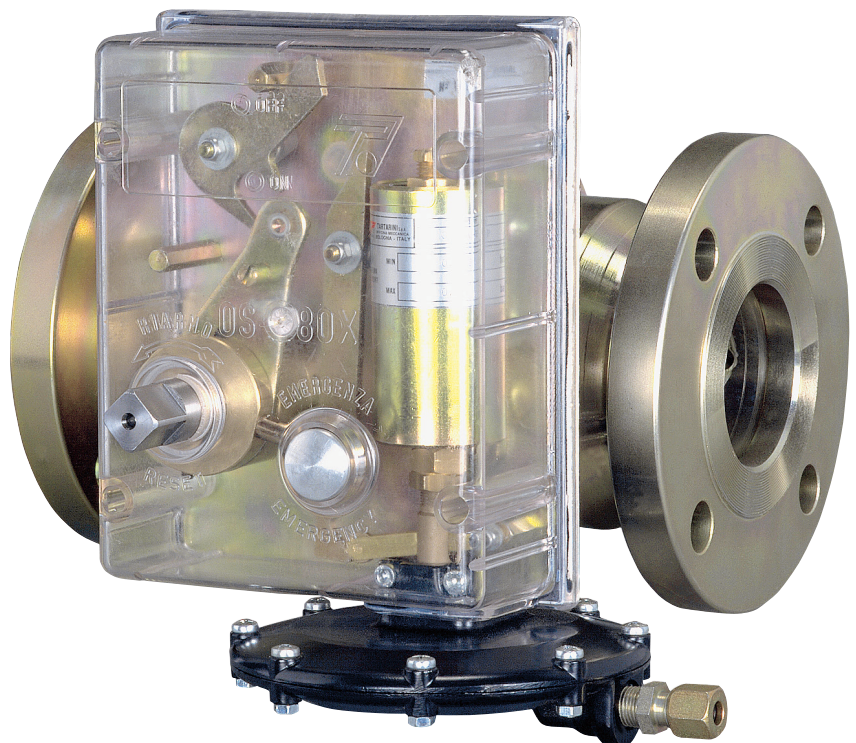

Operation

BM5 Series slam-shut valve is essentially made of an axial flow valve and a pilot allowing to keep the valve open. The valve body features a shutter valve sliding axially and as a consequence no by-pass is needed for its opening even in the presence of pressurized gas.

The valve opening can be made only manually by turning the eccentric shaft anticlockwise. The seal pad is not hit by the gas flow since it is protected by the pad holder and as a consequence is not affected by any possible dirt present in the gas. When the controlled pressure is within set values of the pilot, this remains set and prevents the rotation of the eccentric shaft. When this pressure varies beyond setting limits, the pilot releases the eccentric shaft and the valve is brought to its closing position following the spring thrust.

The pilot is provided with a manual release push-button to quickly close the slam-shut valve in case of emergency or during maintenance/checking operations.

Should the valve be used with pilot-operated pressure regulators, the supply to pilots should be taken downstream of the slam-shut valve. For this purpose, BM5 Series valves feature a threaded hole to be used for supply to pilots; the hole is normally kept closed by a dowel. The supply to pilots can be made through a standard joint or through the suitable stud supplied on request.

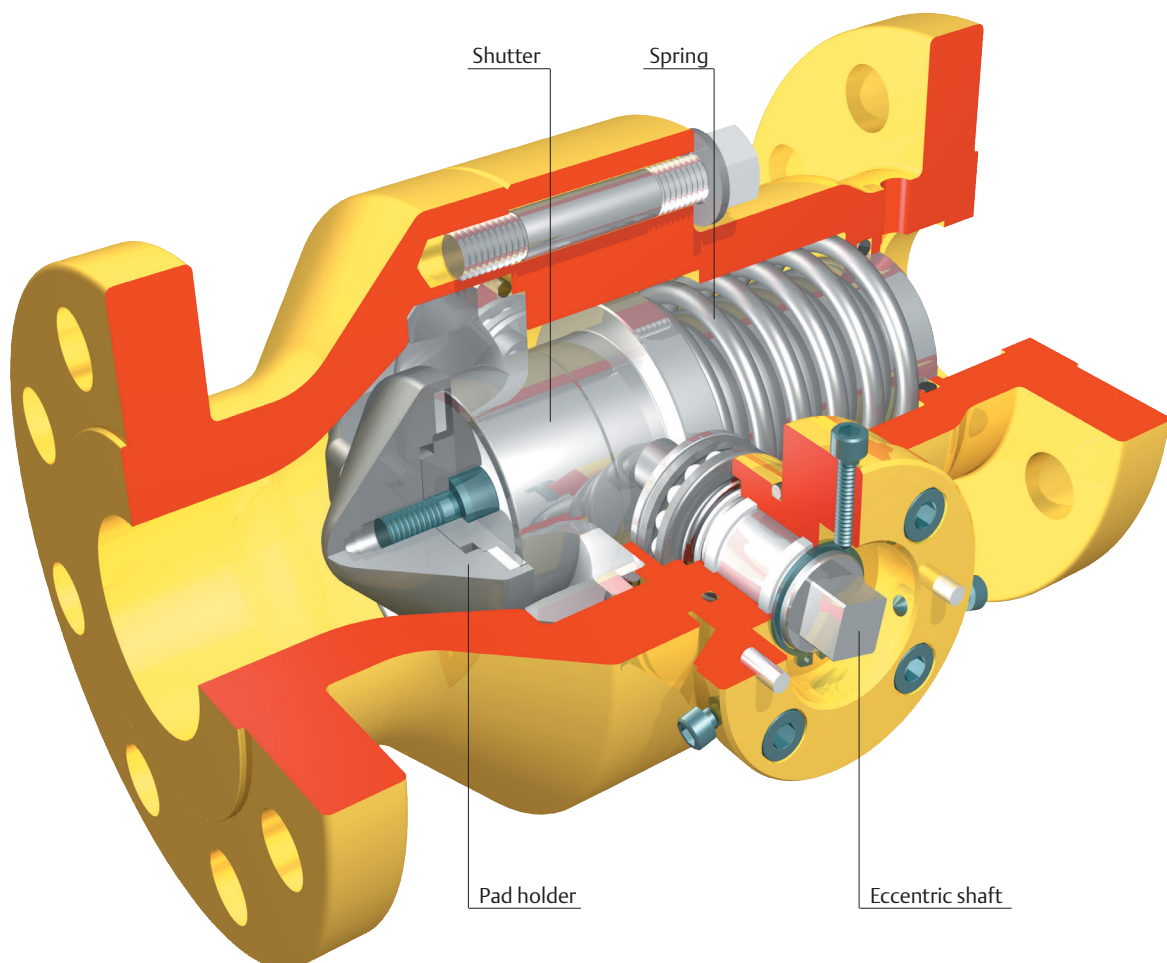
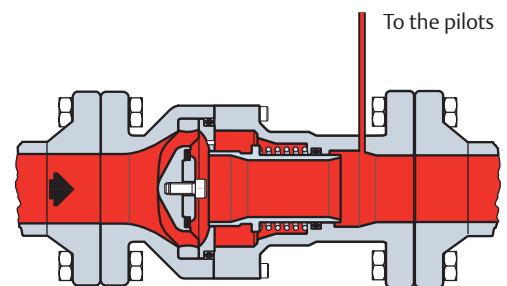

BM5 Slam-Shut Valves

Features

Applications

The slam-shut valves in the BM5 Series are used in natural gas reduction, distribution and transfer stations.

This product has been designed to be used with fuel gases of 1st and 2nd family according to EN 437 and with other non aggressive and non fuel gases. For any other gases, other than natural gas, please contact your local sales agent.

Slam-shut has been evaluated for material compatibility, potential leakage and permeation and susceptibility to embrittlement for blending applications. Based on an extensive evaluation and testing program, BM5 Series configurations are available for use in Hydrogen applications.

Construction Features

The flange coupling surfaces are normally supplied with a step and finished with a semicircular profile phonographic groove.

Upon request, the flange coupling surfaces can be supplied with a smooth finish.

Technical Features

Pressure, bar	PN 16	PN 25	ANSI 150	ANSI 300	ANSI 600
Allowable pressure, PS	16	25	20	50	100
Inlet pressure range, b_{pu}	0 ÷ 16	0 ÷ 25	0 ÷ 20	0 ÷ 50	0 ÷ 100
Overpressure set range, W_{do}	0.03 ÷ 16	0.03 ÷ 25	0.03 ÷ 20	0.03 ÷ 50	0.03 ÷ 80
Underpressure set range, W_{du}	0.01 ÷ 16	0.01 ÷ 25	0.01 ÷ 20	0.01 ÷ 50	0.01 ÷ 80
Accuracy class, AG	up to ± 1%				
Response time, t_a	≤ 1 s				

Flanged connections

DN 25 - 40 - 50 - 65 - 80 - 100 - 150

Temperature

Standard version

Working -10°C +60°C

Low temperature version

Working -20°C +60°C

Materials

Body:	Steel
Shutter:	Steel
O-ring:	Nitrile (NBR) rubber or Fluorocarbon (FKM)
Pad:	Nitrile (NBR) rubber or Fluorocarbon (FKM)
Pad holder:	Steel

Calculation procedures

The following formulas refer to normal operating conditions in a sub-critical state with: $P_2 > \frac{P_1}{2}$

Symbols

Q = Natural gas flow rate in Stm³/h
 P1 = Absolute inlet pressure in bar
 P2 = Absolute outlet pressure in bar

C_g = Flow rate coefficient
 C1 = Body shape factor
 d = Relative density of the gas

Flow Coefficients

Coefficient	DN 25	DN 40	DN 50	DN 65	DN 80	DN 100	DN 150
C _g	525	1420	2250	3600	5400	8700	18600
C1	29	28	26	28	30	26	28

Flow Rate Q

$$Q = 0.525 \cdot C_g \cdot P_1 \cdot \text{sine} \left(\frac{3417}{C_1} \cdot \sqrt{\frac{P_1 - P_2}{P_1}} \right)^\circ$$

N.B. The sine argument is expressed in sexagesimal degree.

$$Q = 0.525 \cdot C_g \cdot P_1$$

For other gases with different densities, the flow rate calculated with the above formulas must be multiplied by the correction factor:

$$F = \sqrt{\frac{0.6}{d}}$$

Gas	Relative Density, d	Factor, F
Air	1	0.78
Butane	2.01	0.55
Propane	1.53	0.63
Nitrogen	0.97	0.79

DN Size

Calculate the required C_g with the following:

$$C_g = \frac{Q}{0.525 \cdot P_1 \cdot \text{sine} \left(\frac{3417}{C_1} \cdot \sqrt{\frac{P_1 - P_2}{P_1}} \right)^\circ}$$

N.B. The sine argument is expressed in sexagesimal degree.

N.B. The formula appearing above is valid only when the flow rate refers to natural gas. For other gases, divide the flow rate by the correction factor F.

Choose the slam-shut valve with the C_g higher than the calculated value. After having determined the slam-shut valve diameter, it is suggested to check that the velocity on the seal seat is not higher than 80 m/sec. by using the following formula:

$$V = 345.92 \cdot \frac{Q}{DN^2} \cdot \frac{1 - 0.002 \cdot P_u}{1 + P_u}$$

V = Velocity (m/s)

345.92 = Numerical constant

Q = Flow rate under standard conditions (Stm³/h)

DN = Valve nominal diameter (mm)

P_u = Inlet pressure in relative value (bar)

In case of velocities higher than indicated limits, increase the valve diameter.

BM5 Slam-Shut Valves

Pilot

The following pilots are used with the BM5 Series slam-shut valves:

- OS/80X Series: Spring loaded pneumatic device
- OS/80X-PN Series: Pneumatic device controlled by PRX-PN Series pilots

OS/80X

The OS/80X Series pilot is supplied in different models according to set ranges required.

The Type BM5 DN 150 is equipped with a reinforced Type OS/80X-R.

Technical Features

Type	Body Resistance, bar	Overpressure Set Range W_{do} , bar		Underpressure Set Range W_{du} , bar	
		Min.	Max.	Min.	Max.
OS/80X-BP	5	0.03	2	0.01	0.60
OS/80X-BPA-D	20				
OS/80X-MPA-D	100	0.50	5	0.25	4
OS/80X-APA-D		2	10	0.30	7
OS/84X		5	41	4	16
OS/88X		18	80	8	70

Materials

Type OS/80X

Servomotor body: OS/80X-BP, OS/80X-BPA-D Aluminum
 OS/80X-MPA-D, OS/80X-APA-D Steel
 Diaphragm: Fabric-finished Nitrile (NBR)
 O-ring: Nitrile (NBR) rubber

Type OS/84X, OS/88X

Servomotor body: Brass
 Lip seal: Teflon (PTFE)
 O-ring: Nitrile (NBR) rubber



OS/80X-BP

OS/80X-PN

The OS/80X-PN Series pilot is supplied in two models:

Type OS/80X-PN: Pressure range 0.5 to 40 bar.

Appliance made of a Type OS/80X-APA-D set at about 0.4 bar and a variable number of Type PRX/182-PN pilots for overpressure and Type PRX/181-PN for underpressure, as many as necessary to control different points of the installation.

Type OS/84X-PN (Safety Accessory): Pressure range 30 to 80 bar.

Appliance made of an OS/84X set at about 20 bar and a variable number of Type PRX-AP/182-PN pilots for overpressure and Type PRX-AP/181-PN for underpressure, as many as necessary to control different points of the installation.

Technical Features

Type	Body Resistance, bar	Overpressure Set Range W_{do} , bar		Underpressure Set Range W_{du} , bar	
		Min.	Max.	Min.	Max.
OS/80X-PN	100	0.5	40	0.5	40
OS/84X-PN	100	30	80	30	80

Materials

Types PRX/181/182-PN and PRX-AP/181/182-PN

Body: Steel
 Diaphragm: Fabric-finished Nitrile (NBR)
 O-ring: Nitrile (NBR) rubber

Installation and assembly

Orientations The BM5 Series slam-shut valves can be installed on the piping with both horizontal axis and vertical axis and with any gas flow orientation.

The pilot can be turned by 90° steps to allow the orientation in vertical position with the adjusting screws turned upwards in order to obtain an optimal operation and an easier setting control.

To reduce the overall dimensions in a particular installation, the Type OS/80X-S version with clockwise resetting is available.

This slam-shut valve has been designed to work even in the presence of relatively dirty gas since the seal pad is not hit directly by the gas flow.

However, being a safety device, it is suggested to install a filter upstream of it.

Horizontal Flow

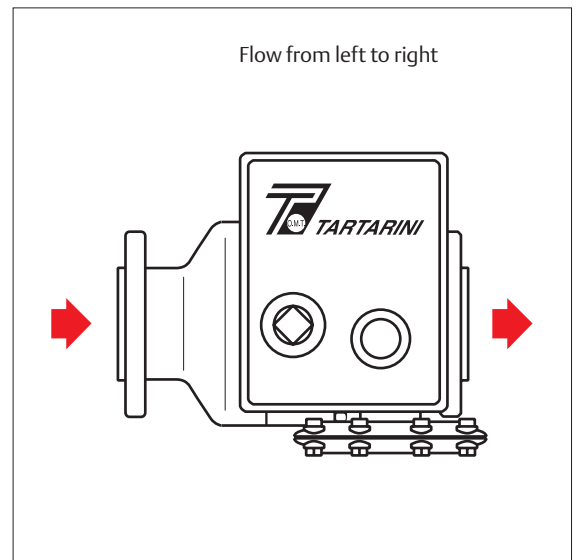
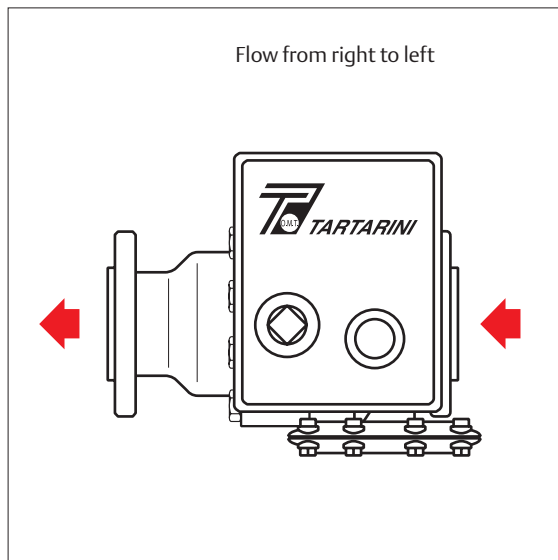

Vertical Flow

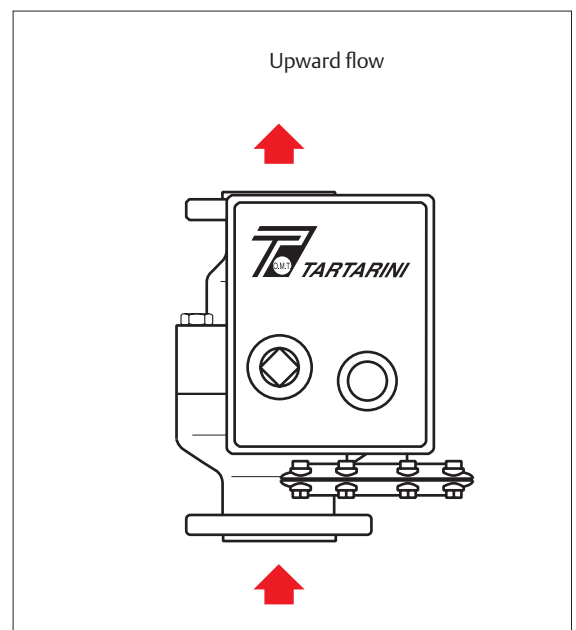
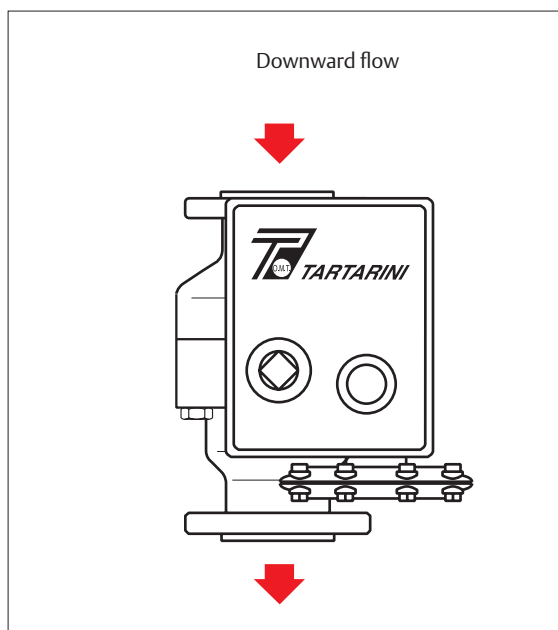

BM5 Slam-Shut Valves

Accessories

Proximity Switch

In order to send the shut-off opening/closing signal, a proximity switch suitable for installation in hazardous area is used.

The use of this switch foresees the application of an intrinsic safety separation barrier which should be installed in safe area.

The distance between the proximity switch and the barrier should be calculated according to the type of gas and installation electrical specifications.

The proximity switch should be positioned at about 0.5 mm from the stem (S).

The adjustment is made by means of adjusting nuts.

On request it is possible to supply the pilot in the version with two proximity switches in order to indicate extreme positions of valve opening/closing.

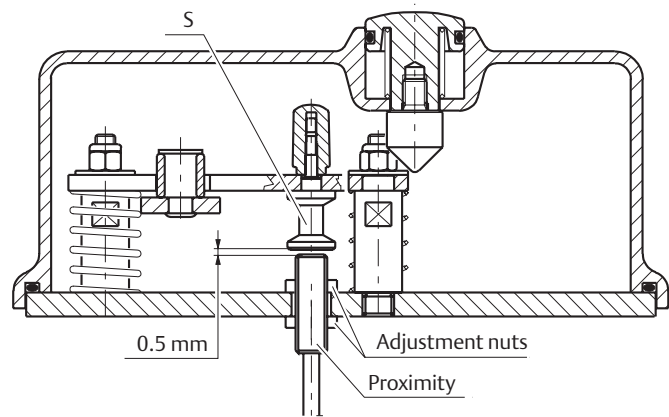

Electrovalve for Remote Controlled Closure

The Types OS/80X and OS/80X-PN equipped with a shut-off device for minimum pressure, can be equipped with a 3-way valve with explosion-proof construction to permit remote-controlled closure.

IT/3V Three-Way Valve for Setting Control (P_u max 50 bar)

It allows the Type OS/80X operation and setting control, without having to change the regulator setting.

The valve is installed on the Type OS/80X control line and it must be connected to a suitable pressure source that is capable of reaching the settings of the Type OS/80X.

The Type IT/3V three-way valve is of the spring-return type and it is equipped with a safety lock plate (B) on the control knob (Q).

When the plate (B) is pivoted, pressure on the knob (Q) makes it possible to put the sensitive member into communication with a pressure source, thus making it possible to perform operation and setting tests.

Upon completion of the procedures, releasing the knob will reset normal running conditions. The safety lock plate on the knob prevents accidental maneuvers.

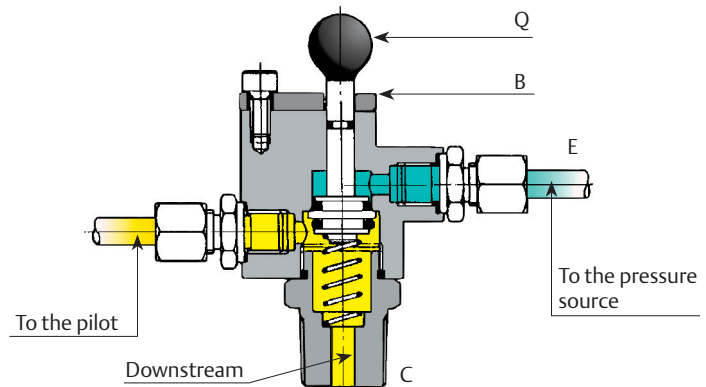
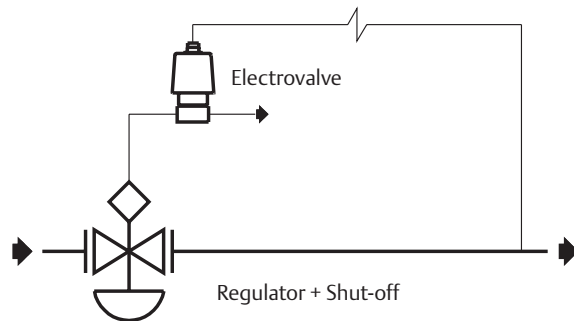

Examples of Connections

Installation in a low pressure regulating line.

Type OS/80X

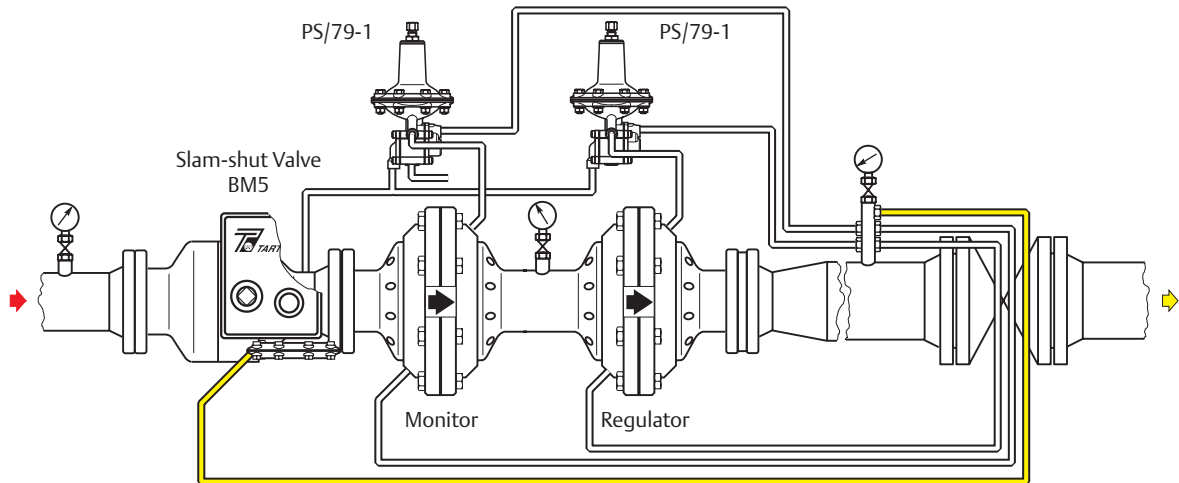

Overpressure and underpressure control downstream of regulators

Type OS/80X-PN

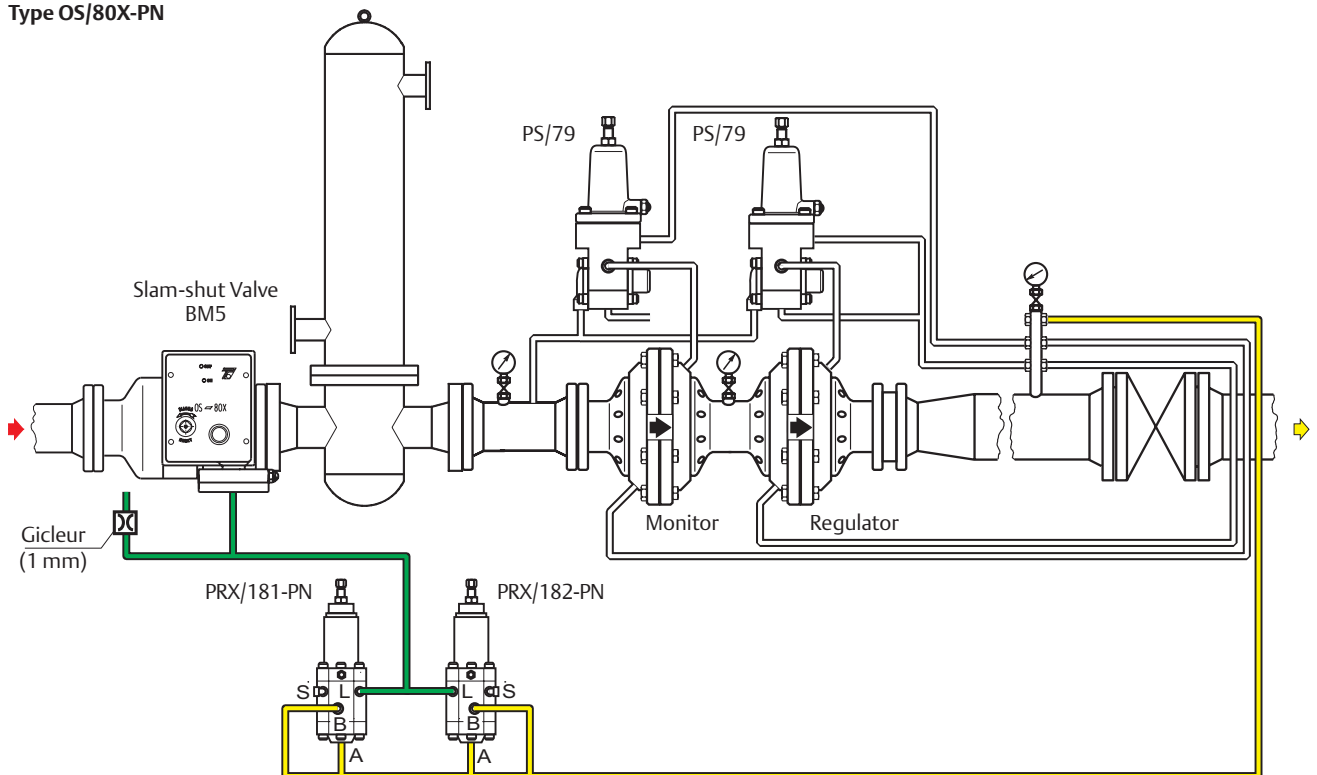

■ Downstream pressure
 ■ Atmospheric pressure

BM5 Slam-Shut Valves

Overall Dimensions, mm

Vertical Assembly

Horizontal Assembly

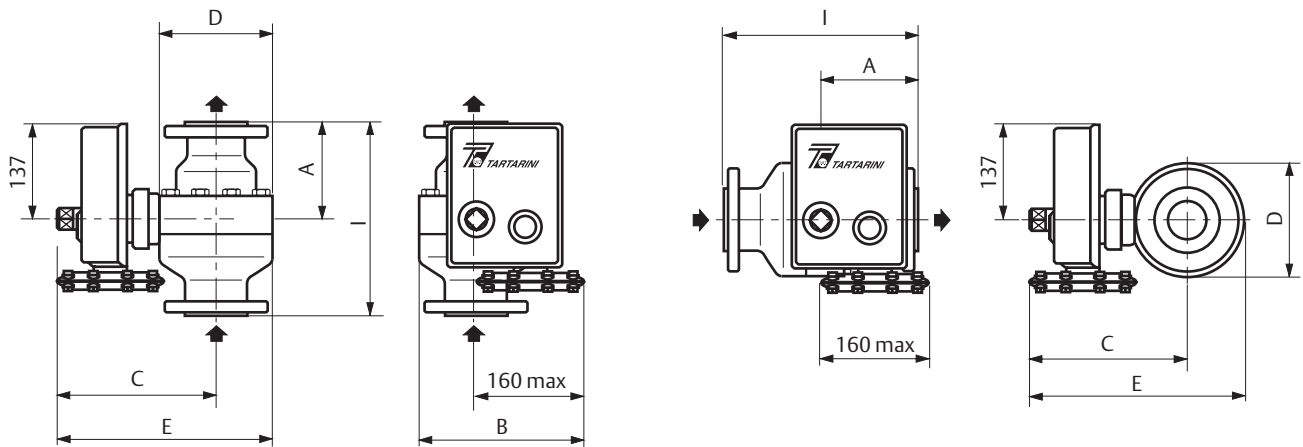

Type	DN 25	DN 40	DN 50	DN 65	DN 80	DN 100	DN 150	
A	100	125	145	155	165	195	250	
B	220	235	245	255	275	295	365	
C	200	205	215	225	245	270	380	
D	125	155	165	190	230	275	410	
E	260	280	300	320	360	410	585	
PN 16	I	184	222	254	276	298.5	352.5	451
PN 25		184	-	254	-	298.5	352.5	451
ANSI 150		184	222	254	276	298.5	352.5	451
ANSI 300		197	235	266.5	292	317.5	368.5	473
ANSI 600		210	251	286	311	336.5	394	508

N.B. The C dimensions are indicative and refer to the models with larger dimensions.
The threaded opening for the connection of the control line is 1/4" NPT female.

Weights, kg

Type	DN 25	DN 40	DN 50	DN 65	DN 80	DN 100	DN 150
PN 16/25 - ANSI 150	15	21	26	38	54	83	170
ANSI 300/600	17	25	30	41	62	105	280

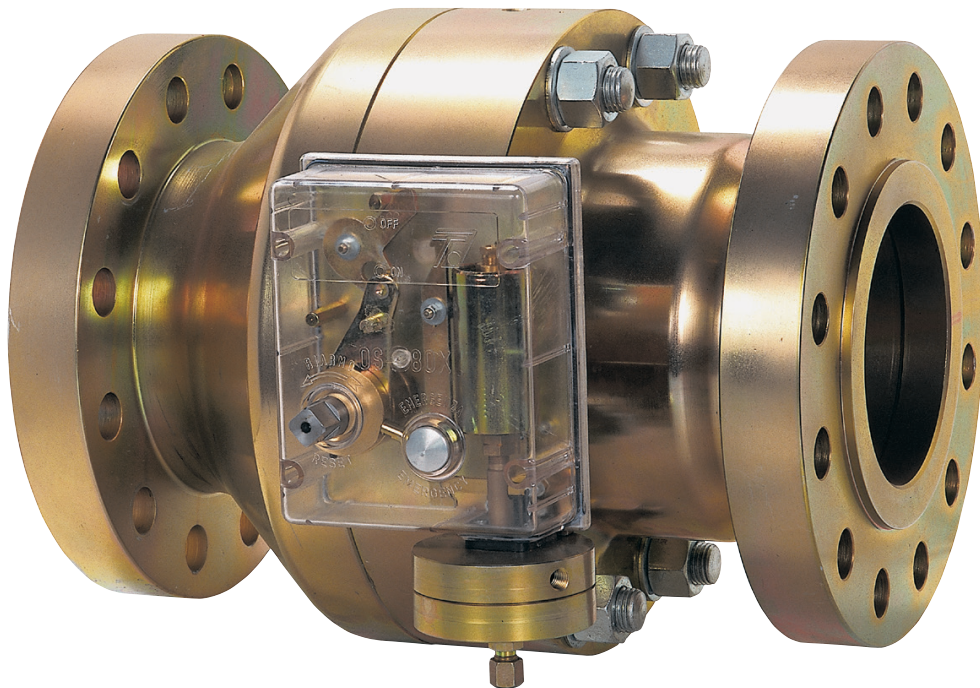

Slam-Shut valve BM5/150 ANSI 600 with OS/80X-APA

✉ Webadmin.Regulators@emerson.com

🔍 Tartarini-NaturalGas.com

📘 Facebook.com/EmersonAutomationSolutions

🌐 LinkedIn.com/company/emerson-automation-solutions

🐦 Twitter.com/emr_automation

Emerson Automation Solutions

Americas

McKinney, Texas 75070 USA

T +1 800 558 5853

+1 972 548 3574

Europe

Bologna 40013, Italy

T +39 051 419 0611

Asia Pacific

Singapore 128461, Singapore

T +65 6777 8211

Middle East and Africa

Dubai, United Arab Emirates

T +971 4 811 8100

D104043X012 © 2018, 2023 Emerson Process Management Regulator Technologies, Inc. All rights reserved. 06/23.

The Emerson logo is a trademark and service mark of Emerson Electric Co. All other marks are the property of their prospective owners. Tartarini™ is a mark owned by one of the companies in the Emerson Automation Solutions business unit of Emerson Electric Co.

The contents of this publication are presented for informational purpose only and while every effort has been made to ensure their accuracy, they are not to be construed as warranties or guarantees, express or implied, regarding the products or services described herein or their use or applicability. All sales are governed by our terms and conditions, which are available upon request. We reserve the right to modify or improve the designs or specification of such products at any time without notice.

Emerson Process Management Regulator Technologies, Inc. does not assume responsibility for the selection, use or maintenance of any product. Responsibility for proper selection, use and maintenance of any Emerson Process Management Regulator Technologies, Inc. product remains solely with the purchaser.

Emerson Process Management S.R.L.,

Emerson Automation Solutions - Stabilimento di/Site of: Castel Maggiore - Bologna,
Sede Legale/Legal Entity: Piazza Meda 5, 20121 Milano, Italy

Sede Amministrativa/Administrative Headquarters: OMT Tartarini, Via Clodoveo Bonazzi 43,
40013 Castel Maggiore (Bologna), Italy C.F. - P.I. e R.I. di MI 13186130152 - REA di MI/n.1622916
Direz. e Coord. (art. 2497 bis CC): EMERSON ELECTRIC CO. St. Louis (USA) Socio Unico

