



## KTM BALL VALVES FOR INDUSTRIAL AND PROCESS APPLICATIONS

### F190/F190F - SPLIT BODY FLANGED BALL VALVE

High performance two-piece ball valve for demanding process and utility applications



#### FEATURES

- Two-piece, split-body ball valve with flanged ends
- Carbon steel or stainless steel bodies
- Size range DN 15 (NPS ½) to DN 300 (NPS 12) - Full bore
- Valve pressure rating:
  - ANSI Class 150/300
  - DIN PN 10/16/25/40
  - JIS 10K/20K
- Various seat material options
- Investment cast body DN 15 to DN 100
- Sand cast body DN 125 to DN 300
- Model F190F fire tested to API 607
- Patented 'SEALMASTER®' shaft arrangement
- F190 double shaft seal design has been certified to TA-Luft VDI 2440 requirements
- Blow out proof shaft
- ISO 5211 mounting plate
- Anti-static design according to EN 1983/ISO 17292
- Tightness to ISO 5208 rate A and EN 12266-1 rate A
- Locking device
- Patented 'POSILOCK™' handle for DN 15 (NPS ½) to DN 50 (NPS 2) full bore

#### GENERAL APPLICATIONS

The range includes valves ideal for petrochemical, chemical and general industrial applications, as well as service applications including water, oil, gas. The F190F model offers a design suitable for more hazardous services such as fuel and inflammable substances.

#### TECHNICAL DATA

Sizes:	DN 15 to DN 300 NPS ½ to NPS 12
Pressure rating:	PN 10/16 PN 25/40 ANSI 150/300 JIS 10K/20K
End connection Flanged:	PN 10/16, PN 25/40 ANSI Class 150/300 JIS 10K/20K

# KTM BALL VALVES FOR INDUSTRIAL AND PROCESS APPLICATIONS

## F190 - SPLIT BODY FLANGED BALL VALVE

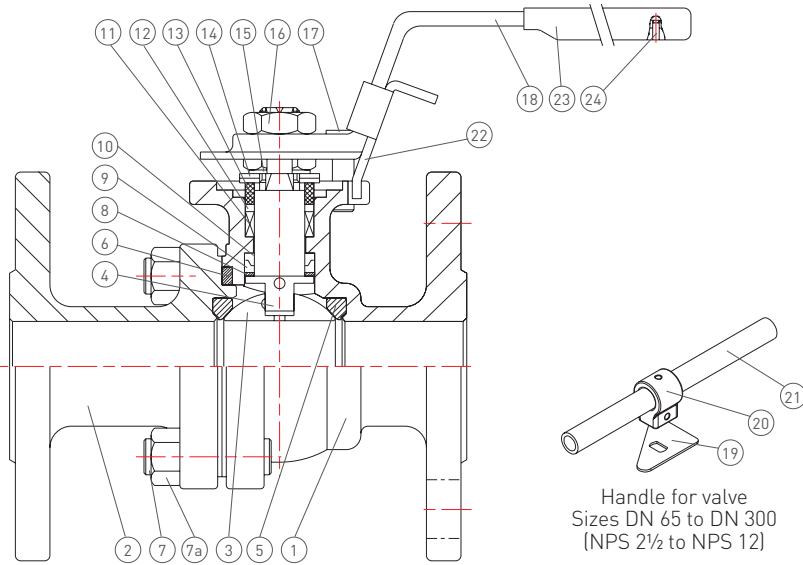

### TOP WORK DIMENSIONS (mm)

Flange type	Ø P	W
F03	36	M5
F04	42	M5
F05	50	M6
F07	70	M8
F10	102	M10
F12	125	M12
F14	140	M16

### MATERIALS OF CONSTRUCTION

No.	Parts name	Material	Quantity
1*	Body	ASTM A351 Gr. CF8M / ASTM A216 Gr. WCB	1
2*	Cap	ASTM A351 Gr. CF8M / ASTM A216 Gr. WCB	1
3	Ball	ASTM A351 Gr. CF8M	1
4	Anti-static shaft	A276 type 316 <sup>(1)</sup>	1
5	Ball seat	PTFE	2
6	Body seal	PTFE	1
7	Stud	A193 Gr. B8 / A193 Gr. B7	4-26
7a	Nut	A194 Gr. 8 / A194 Gr. 2H	4-26
8	Lower shaft seal	50% SS powder / 50% PTFE	1
9	Compress ring	316L SS (DN 15-100) / 316 SS (DN 125-300)	1
10	Upper shaft seal	TFM1600	1
11	V-ring shaft packing	PTFE	1 set
12	Thrust washer	50% SS powder / 50% PTFE	1
13	Gland	304 SS	1
14	Belleville washer	301 SS	2
15	Lock saddle	Stainless steel	1
16	Shaft nut	304 SS	1-2
17	Stop bolt	Stainless steel	1-2
18	Handle (DN 15-50)	CF8	1
19	Triangle stopper (DN 65-300)	Stainless steel	1
20	Handle adapter (DN 65-300)	CF8 (DN 65-125) / A536 (DN 150-300)	1
21	Handle (DN 65-300)	SGP Zn plating	1
22	Locking trigger	Stainless steel	1
23	Handle sleeve	Vinyl	1
24	Rivet	304 SS	1

\* For DIN valves, the body & cap material will be EN 1.4408 / EN 1.0619

\* For JIS valves, the body & cap material will be SCS14A/SCPH2

1. Standard shaft material

Body material	Size	Class 150, 10K, PN 10/16	Class 300, 20K, PN 25/40
CF8M,	DN 15-100	316	316
SCS14A,	DN 150	316	2205 [A276-S31803]
1.4408	DN 200-300	2205 [A276-S31803]	2205 [A276-S31803]
WCB,	DN 15-100	316	316
SCPH2,	DN 150	316	17-4 [A564-630]
1.0619	DN 200-300	17-4 [A564-630]	17-4 [A564-630]

# KTM BALL VALVES FOR INDUSTRIAL AND PROCESS APPLICATIONS

## F190F - SPLIT BODY FLANGED BALL VALVE - FIRE TESTED

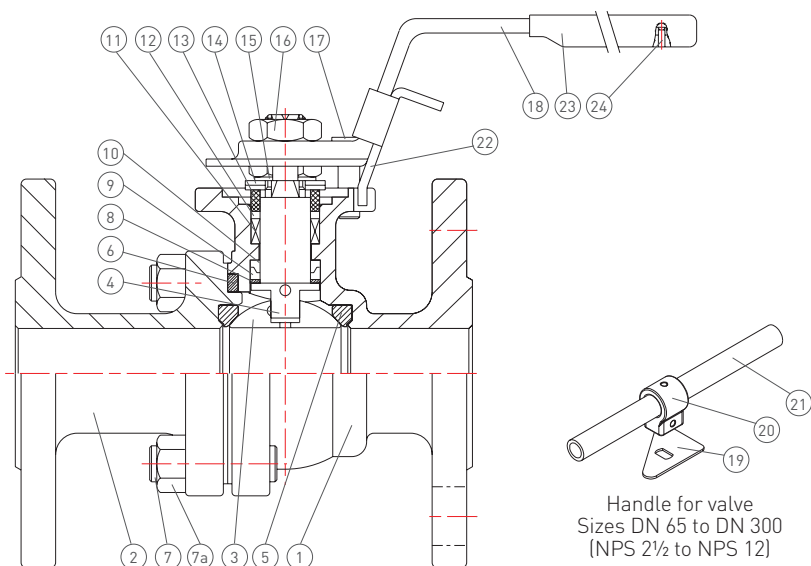

Handle for valve  
 Sizes DN 65 to DN 300  
 (NPS 2½ to NPS 12)

### MATERIALS OF CONSTRUCTION

No.	Parts name	Material	Quantity
1*	Body	ASTM A351 Gr. CF8M / ASTM A216 Gr. WCB	1
2*	Cap	ASTM A351 Gr. CF8M / ASTM A216 Gr. WCB	1
3	Ball	ASTM A351 Gr. CF8M	1
4	Anti-static shaft	A276 type 316 (Note 1)	1
5	Ball seat	PTFE	2
6	Body seal	Graphite (DN 15-100) / 316 SS spiral wound graphite (DN 125-300)	1
7	Stud	A193 Gr. B8 / A193 Gr. B7	4-26
7a	Nut	A194 Gr. 8 / A194 Gr. 2H	4-26
8	Lower shaft seal	50% SS powder / 50% PTFE	1
9	Compress ring	316L SS (DN 15-100) / 316 SS (DN 125-300)	1
10	Upper shaft seal	Graphite	1
11	V-ring shaft packing	Graphite	1 set
12	Thrust washer	50% SS powder / 50% PTFE	1
13	Gland	304 SS	1
14	Belleville washer	301 SS	2
15	Lock saddle	Stainless steel	1
16	Shaft nut	304 SS	1-2
17	Stop bolt	Stainless steel	1-2
18	Handle (DN 15-50)	CF8	1
19	Triangle stopper (DN 65-300)	Stainless steel	1
20	Handle adapter (DN 65-300)	CF8 (DN 65-125) / A536 (DN 150-300)	13
21	Handle (DN 65-300)	SGP Zn plating	1
22	Locking trigger	Stainless steel	1
23	Handle sleeve	Vinyl	1
24	Rivet	304 SS	1

\* For DIN valves, the body & cap material will be EN 1.4408 / EN 1.0619

\* For JIS valves, the body & cap material will be SCS14A/SCPH2

1. Standard shaft material

Body material	Size	Class 150, 10K, PN 10/16	Class 300, 20K, PN 25/40
CF8M,	DN 15-100	316	316
SCS14A,	DN 150	316	2205 (A276-S31803)
1.4408	DN 200-300	2205 (A276-S31803)	2205 (A276-S31803)
WCB,	DN 15-100	316	316
SCPH2,	DN 150	316	17-4 (A564-630)
1.0619	DN 200-300	17-4 (A564-630)	17-4 (A564-630)

# KTM BALL VALVES FOR INDUSTRIAL AND PROCESS APPLICATIONS

## F190 / F190F - SPLIT BODY FLANGED BALL VALVE

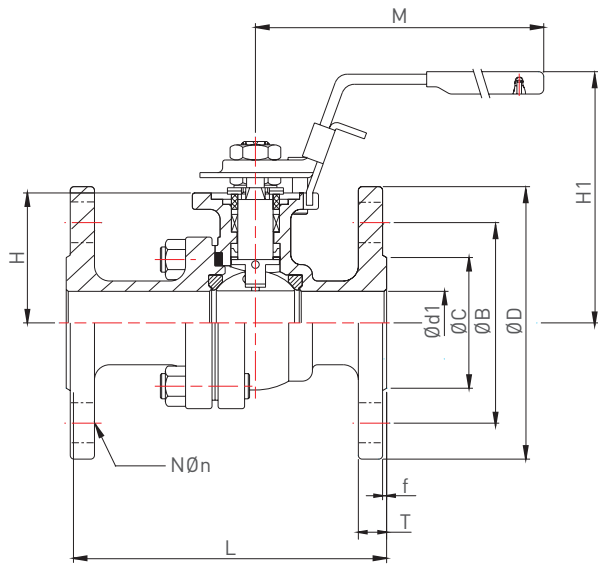

Sizes DN 15-50  
(NPS 1/2-2)

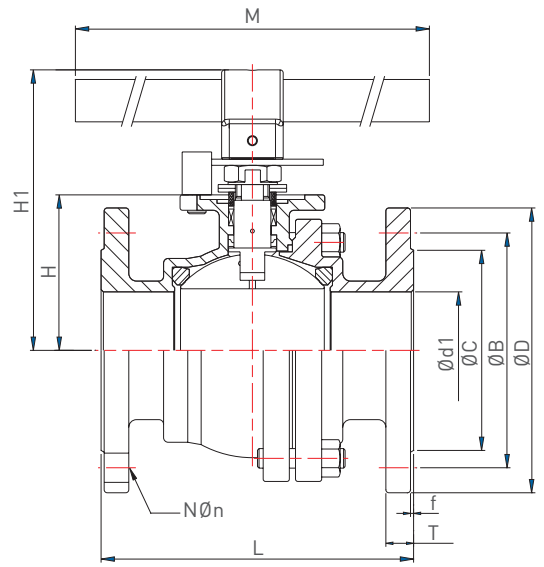

Sizes DN 65-300  
(NPS 2 1/2-12)

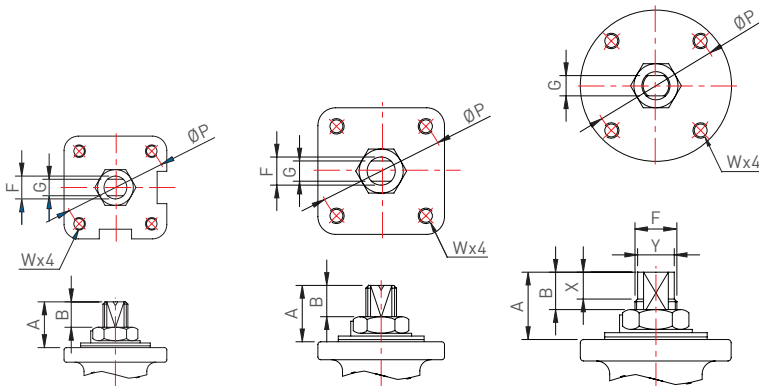

DN 15-100  
(NPS 1/2-4)

DN 125-200  
(NPS 5-8)

DN 250-300  
(NPS 10-12)

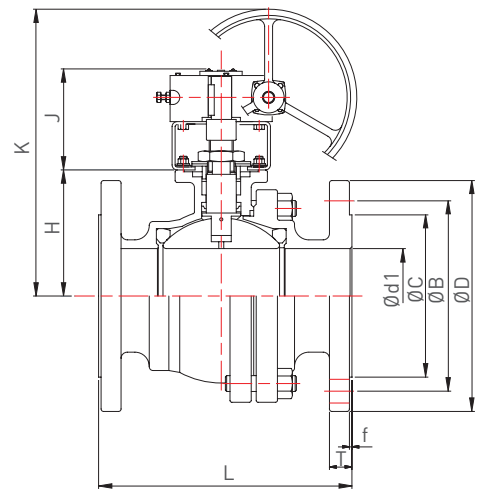

DN 250-300  
(NPS 10-12)  
Optional

### DIMENSIONS (mm)

DN	NPS	A	ØP	F	G	B	W	M	H	H1	J	K	X	Y
15	1/2	20.3	42	9.7	6.3	12.0	M5	135	38.5	82	N/A	N/A	-	-
20	3/4	20.5	42	9.7	6.3	12.4	M5	135	42.0	86	N/A	N/A	-	-
25	1	21.6	50	11.2	8.0	14.0	M6	165	51.5	98	N/A	N/A	-	-
32	1 1/4	21.6	50	11.2	8.0	14.0	M6	165	56.2	102	N/A	N/A	-	-
40	1 1/2	26.0	70	16.0	9.5	16.2	M8	200	65.5	119	N/A	N/A	-	-
50	2	26.0	70	16.0	9.5	16.2	M8	200	74.5	128	N/A	N/A	-	-
65	2 1/2	43.0	102	22.3	17.0	24.7	M10*	495	88.0	162	N/A	N/A	-	-
80	3	43.5	102	22.3	17.0	25.2	M10*	495	101.0	172	N/A	N/A	-	-
100	4	49.0	102	28.6	17.0	30.0	M10*	595	122.0	197	N/A	N/A	-	-
125	5	53.6	102	28.6	17.0	33.0	M10*	595	140.0	226	161	393	-	-
150	6	65.0	125	34.0	23.0	39.0	M12	800	167.0	281	190	513	-	-
200	8	65.0	125	34.0	23.0	39.0	M12	1100	203.0	317	190	549	-	-
250	10	83.5	140	50.0	30.0	52.0	M16	1100	263.0	378	221	625	40	47
300	12	83.5	140	50.0	30.0	52.0	M16	1100	305.0	420	221	667	40	47

N/A = Not applicable

\* For NPS 2 1/2-5 JIS 10K/20K, W=M12

# KTM BALL VALVES FOR INDUSTRIAL AND PROCESS APPLICATIONS

## F190 / F190F - SPLIT BODY FLANGED BALL VALVE

### ANSI 150/300 DIMENSIONS (mm)

DN	NPS	Ø B		Ø D		L		N		T		Ø n		Ø C	Ø d1	f	Wt (kg)	
		150	300	150	300	150	300	150	300	150	300	150	300				150	300
15	½	60.5	66.5	89.0	95.0	108.0	140.0	4	4	11.2	14.3	16.0	16.0	35	15	1.6	1.82	2.20
20	¾	70.0	82.5	98.6	117.0	117.0	152.0	4	4	11.2	15.9	16.0	19.0	43	20	1.6	2.12	3.25
25	1	79.5	89.0	108.0	124.0	127.0	165.0	4	4	11.2	17.5	16.0	19.0	51	25	1.6	3.04	4.48
40	1½	98.5	114.5	127.0	156.0	165.0	190.0	4	4	14.2	20.7	16.0	22.0	73	40	1.6	5.80	8.70
50	2	120.5	127.0	152.5	165.0	178.0	216.0	4	8	15.9	22.3	19.0	19.0	92	50	1.6	8.36	11.20
60	2½	139.5	149.0	178.0	190.0	190.0	241.0	4	8	17.5	25.4	19.0	22.0	105	65	1.6	15.00	19.00
80	3	152.5	168.0	190.5	210.0	203.0	283.0	4	8	19.1	28.6	19.0	22.0	127	76	1.6	19.92	28.00
100	4	190.5	200.0	229.0	254.0	229.0	305.0	8	8	23.9	31.8	19.0	22.0	157	100	1.6	32.90	43.72
125	5	215.9	234.9	254.0	279.4	355.6	381.0	8	8	23.8	34.9	22.2	22.2	186	125	1.6	49.00	71.00
150	6	241.3	269.9	279.4	317.5	393.7	403.4	8	12	25.4	36.6	22.2	22.2	216	150	1.6	75.00	100.00
200	8	298.4	330.2	342.9	381.0	457.2	501.7	8	12	28.6	41.3	22.2	25.4	270	201	1.6	128.00	172.00
250	10	361.9	387.3	406.4	444.5	533.4	568.5	12	16	30.2	47.6	25.4	28.6	324	250	1.6	215.00	291.00
300	12	431.8	450.8	482.6	520.7	609.6	647.7	12	16	31.8	50.8	25.4	31.8	381	300	1.6	254.00	423.00

### DIN PN 10/16/25/40 DIMENSIONS (mm)

DN	NPS	PN	Ø B	Ø C	Ø D	L	L*	N	T	Ø n	Ø d1	f	Wt (kg)	
													F1	F4/F5
15	½	10/16/25/40	65	45	95	115	130	4	16	14	15	2	2.42	2.46
20	¾	10/16/25/40	75	58	105	120	150	4	18	14	20	2	3.24	3.08
25	1	10/16/25/40	85	68	115	125	160	4	18	14	25	2	4.42	4.18
32	1¼	10/16/25/40	100	78	140	130	180	4	18	18	32	2	6.10	5.62
40	1½	10/16/25/40	110	88	150	140	200	4	18	18	40	2	7.94	7.40
50	2	10/16/25/40	125	102	165	150	230	4	20	18	50	2	10.50	9.76
65	2½**	10/16	145	122	185	170	290	4	18	18	65	2	17.00	16.60
		25/40	145	122	185	170	290	8	22	18	65	2	18.30	16.22
80	3	10/16	160	138	200	180	310	8	20	18	80	2	21.50	21.40
		25/40	160	138	200	180	310	8	24	18	80	2	24.90	21.34
100	4	10/16	180	158	220	190	350	8	20	18	100	2	34.00	27.72
		25/40	190	162	235	190	350	8	24	22	100	2	37.20	31.42
125	5	10/16	210	188	250	325	400	8	22	18	125	2	50.00	48.00
		25/40	220	188	270	325	400	8	26	26	125	2	60.00	57.00
150	6	10/16	240	212	285	350	480	8	22	22	150	2	78.00	73.00
		25/40	250	218	300	350	480	8	28	26	150	2	92.00	82.00
200	8	10	295	268	340	400	600	8	24	22	200	2	124.00	98.00
		16	295	268	340	400	600	12	24	22	200	2	124.00	98.00
		25	310	278	360	400	600	12	30	26	200	2	164.00	148.00
		40	320	285	375	400	600	12	34	30	200	2	164.00	148.00
250	10	10	350	320	395	450	730	12	26	22	250	2	270.00	203.00
		16	355	320	405	450	730	12	26	26	250	2	270.20	203.00
300	12	10	400	370	445	500	850	12	26	22	300	2	N/A	233.00
		16	410	378	460	500	850	12	28	26	300	2	N/A	233.00

L Dimensions DN 15 - 100, DIN F4; DN 125 - 300 DIN F5 (L Dimensions to ISO 5752 series 27, EN 558 series 27)

L\* Dimensions DN 15 - 300 to DIN F1 (L Dimensions to ISO 5752 series 1, EN 558 series 1)

### JIS 10K/20K DIMENSIONS (mm)

DN	NPS	Ø B		Ø C		Ø D		L		N		T		Ø n		J	K	Ø d1	f	H	Wt (kg)	
		10K	20K	10K	20K	10K	20K	10K	20K	10K	20K	10K	20K	10K	20K							
15A	½	70	70	51	51	95	95	108	140	4	4	12	14	15	15	N/A	N/A	15	1	38.5	2.10	2.36
20A	¾	75	75	56	56	100	100	117	152	4	4	14	16	15	15	N/A	N/A	20	1	42.0	2.50	2.80
25A	1	90	90	67	67	125	125	127	165	4	4	14	16	19	19	N/A	N/A	25	1	51.5	3.86	4.55
32A	1¼	100	N/A	76	N/A	135	N/A	140	N/A	4	N/A	16	N/A	19	N/A	N/A	N/A	32	2	56.2	5.50	N/A
40A	1½	105	105	81	81	140	140	165	190	4	4	16	18	19	19	N/A	N/A	40	2	65.5	6.48	7.16
50A	2	120	120	96	96	155	155	178	216	4	8	16	18	19	19	N/A	N/A	50	2	74.5	8.40	8.92
65A	2½	140	140	116	116	175	175	190	241	4	8	18	20	19	22	N/A	N/A	65	2	90.0	13.80	15.50
80A	3	150	160	126	136	185	200	203	283	8	8	18	22	19	23	N/A	N/A	76	2	101.0	18.60	23.24
100A	4	175	185	151	160	210	225	229	305	8	8	18	24	19	23	N/A	N/A	100	2	122.0	27.36	34.10
125A	5	210	225	185	195	250	270	356	381	8	8	20	26	23	25	161	393	125	2	140.0	46.00	69.00
150A	6	240	260	212	230	280	305	394	403	8	12	22	28	23	25	190	513	150	2	167.0	73.00	92.00
200A	8	290	305	262	275	330	350	457	502	12	12	22	30	23	25	190	549	201	2	203.0	120.00	139.00
250A	10	355	380	324	345	400	430	533	568	12	12	24	34	25	27	221	625	250	2	263.0	201.00	291.00
300A	12	400	430	368	395	445	480	610	648	16	16	24	36	25	27	221	667	300	3	305.0	254.00	423.00

N/A = Not applicable

# KTM BALL VALVES FOR INDUSTRIAL AND PROCESS APPLICATIONS

## F190 - SPLIT BODY FLANGED BALL VALVE

### POSILOCK™ HANDLE

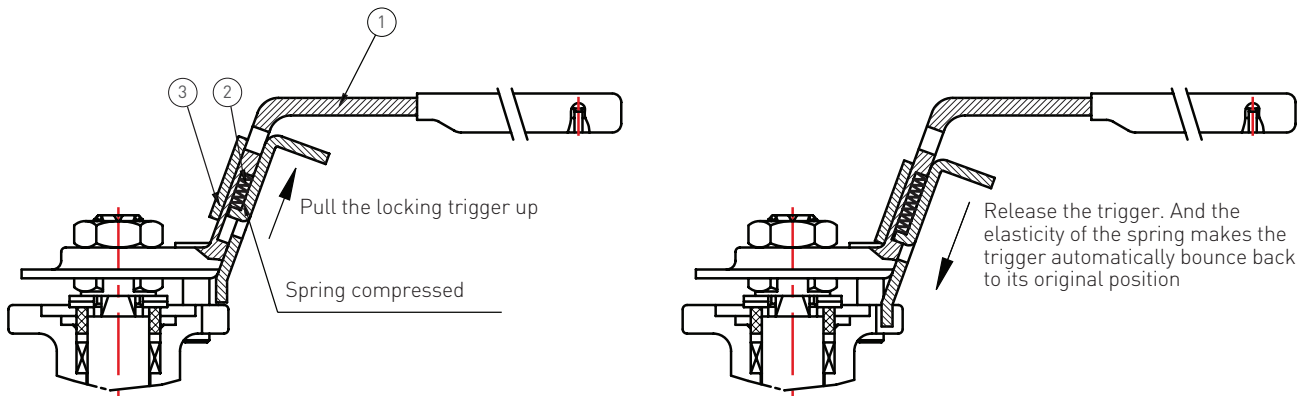

### FEATURES

- Simple construction
- Smooth action for locking trigger
- Wrapped locking trigger design prevents the spring from coming out
- The elasticity of the spring makes the trigger automatically bounce back to its original position, which keeps the plate in position for firm locking. This also avoids unwanted valve operation caused by accident.

### PARTS LIST

No.	Parts name
1	Handle
2	Spring
3	Locking trigger

### F190/F190F DIFFERENTIAL - PRESSURE TORQUE (SEAT: PTFE)

DN	NPS	Pressure unit: bar (psi)							
		0	6.9 (100)	13.8 (200)	20.7 (300)	27.6 (400)	34.5 (500)	42.2(600)	49.2 (700)
		Torque unit: Nm							
15	½	8.4	8.6	8.7	8.9	9.1	9.5	10.0	10.6
20	¾	11.5	12.5	12.5	13.0	13.0	13.5	14.5	15.5
25	1	13.5	13.5	14.0	14.5	15.0	16.0	17.0	18.5
32	1¼	14.0	14.2	14.4	15.3	16.8	18.1	19.8	21.6
40	1½	23.5	24.0	24.5	25.0	25.5	26.0	27.0	28.5
50	2	30.5	31.0	31.5	31.5	32.0	32.5	33.5	35.0
65	2½	42.5	46.0	50.0	52.0	58.0	65.0	72.0	80.0
80	3	58.0	82.0	100.0	125.0	145.0	155.0	170.0	185.0
100	4	82.0	88.0	110.0	145.0	175.0	210.0	250.0	295.0
125	5	125.0	130.0	150.0	190.0	240.0	300.0	-	-
150	6	175.0	240.0	305.0	490.0	650.0	750.0	-	-
200	8	180.0	300.0	420.0	690.0	870.0	-	-	-
250	10	350.0	760.0	1250.0	1700.0	2050.0	-	-	-
300	12	470.0	870.0	1500.0	2350.0	-	-	-	-

### NOTES:

1. Increase by 25% for MG1241, carbon & SS filled seat.
2. Increase by 15% for dry gas or oil free products.
3. Increase by 40% for dry gas (-10°C and below).
4. Increase by 40% for gas or liquid with slurry powder (above -10°C).
5. Increase by 40% for high viscosity fluid (above -10°C).
6. For actuator sizing, we recommend to add at least 20% of the break-away torque of valve as safety factor.
7. Valve torques refer to ball valves with full port. For reduce port valve torque take one size smaller.

# KTM BALL VALVES FOR INDUSTRIAL AND PROCESS APPLICATIONS

SEALMASTER®

## PATENTED SEALMASTER® SHAFT SEAL ARRANGEMENT

Our extremely high cycle shaft sealing design is accomplished by double sealing system. The high performance of KTM F190 ball valves is mainly due to unique SEALMASTER® shaft seal arrangement, which provides a primary sealing. It has been specially designed and constructed to prevent line fluid permeation and resultant leakage. On top of this arrangement are multiple layers of V-ring shaft packing this acts as secondary sealing. A set of Belleville washers automatically and constantly compresses the seals to adjust for wear, pressure and temperature fluctuations. Every KTM F190 ball valve is a stalwart barrier against Fugitive Emissions.

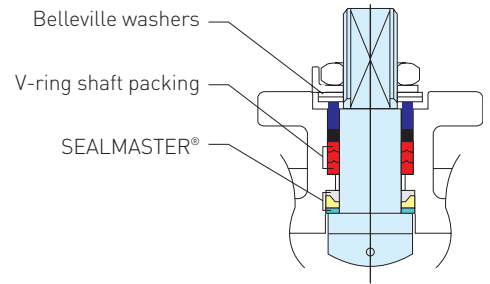

## EXPLANATION OF SEALMASTER®

The live loaded SEALMASTER® is a combination of 3 components; (A) a cup and cone PFA/TFE upper thrust seal, (B) a cup and cone sintered 316 SS center load ring and (C) a flat SS/TFE lower thrust seal. When tightened, the live loaded shaft pulls up and compressing the shaft thrust seals. As this happens, material from upper and lower thrust seal extrude between shaft and body enclosures. (See 1-6). The surfaces between the bottom of lower thrust seal and top of shaft flange are smooth and all rotation occurs between these two surfaces leaving the shaft thrust seal 'static' to create the best possible seal. As rotation continues, components bed in and keep seal performance constant with usage.

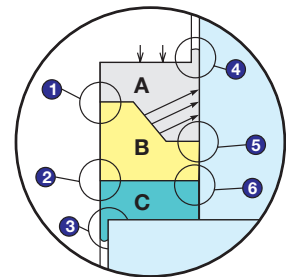

## MAIN FEATURES OF SEALMASTER® - PATENTED SHAFT SEAL ARRANGEMENT

- MULTIPLE sealing up to 6 areas (see view 1 - 6).
- Encapsulated STATIC sealing achieved on upper thrust seal.
- Constant sealing force transmitted to shaft (see arrow) making shaft primary sealing 'positive'.
- Excellent wear resistance on lower thrust seal (50% SS filled PTFE).
- Reduced seal friction as a result of better than Ra 0.8 µm (150 grit) shaft finish.

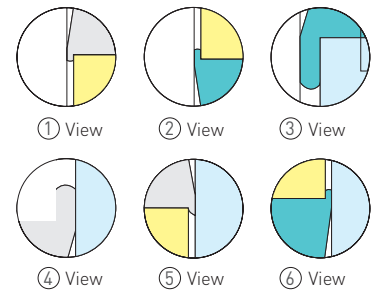

## SHAFT SEAL ARRANGEMENT

Patented SEALMASTER®  
DN 15-300 (NPS ½-12) F190

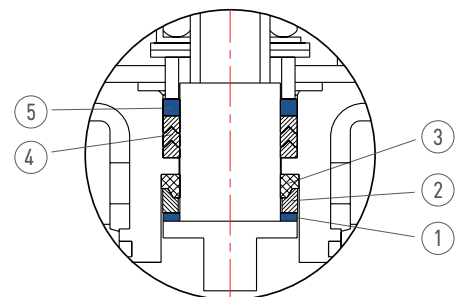

No.	Part name	Material	Patented SEALMASTER® shaft seal arrangement
1	Lower thrust washer	50% SS powder / 50% PTFE	•
2	Compress ring	316 SS	•
3	Upper thrust washer	TFM1600	•
4*	V-ring shaft packing	PTFE	•
5	Thrust washer	50% SS powder / 50% PTFE	•

• means available

\* For the F190F, the V-ring PTFE shaft packing is replaced by graphite packing

# KTM BALL VALVES FOR INDUSTRIAL AND PROCESS APPLICATIONS

## F190/F190F - PRESSURE/TEMPERATURE CHARTS

F190/F190F - ANSI  
SPLIT-BODY FLANGED BALL VALVE  
DN 15-20 (NPS 1/2-3/4) - FULL BORE

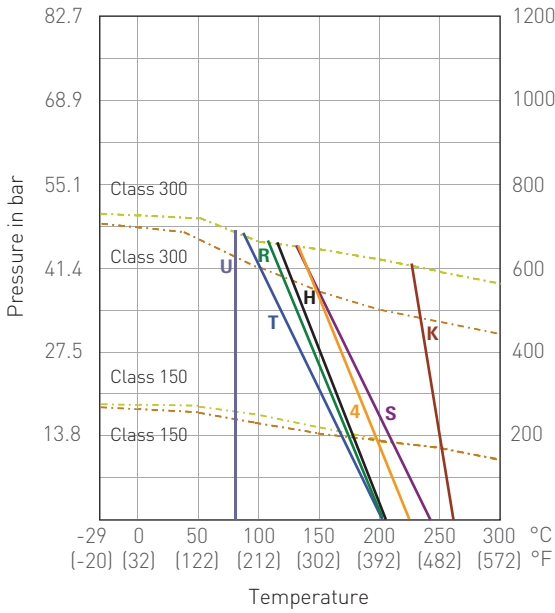

F190/F190F - ANSI  
SPLIT-BODY FLANGED BALL VALVE  
DN 25-65 (NPS 1-2 1/2) - FULL BORE

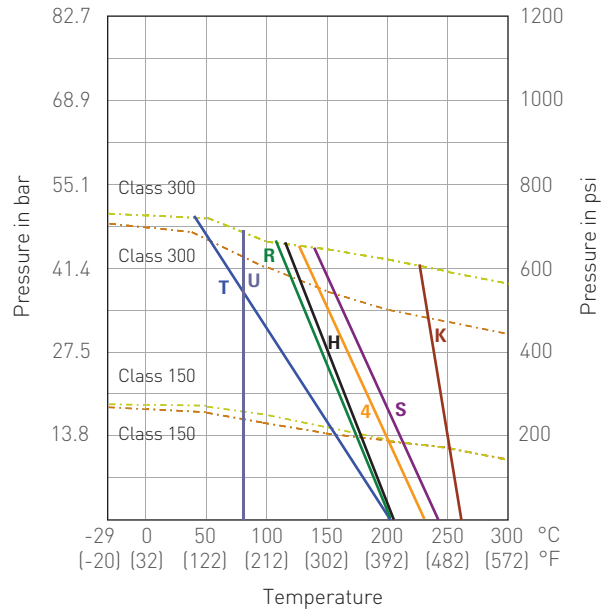

F190/F190F - ANSI  
SPLIT-BODY FLANGED BALL VALVE  
DN 80-100 (NPS 3-4) - FULL BORE

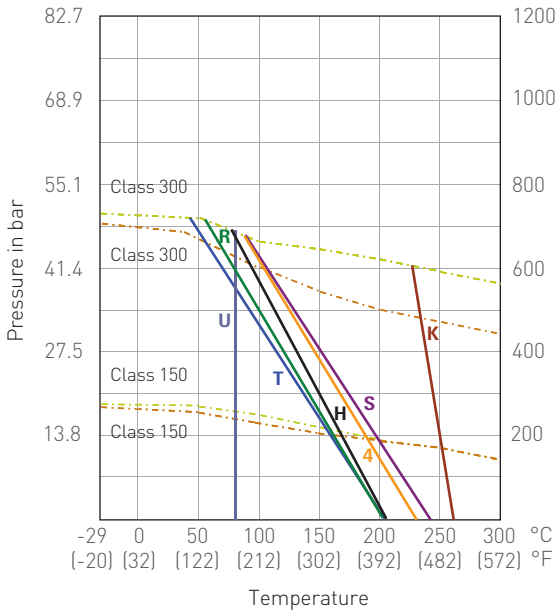

F190/F190F - ANSI  
SPLIT-BODY FLANGED BALL VALVE  
DN 125-300 (NPS 5-12) - FULL BORE

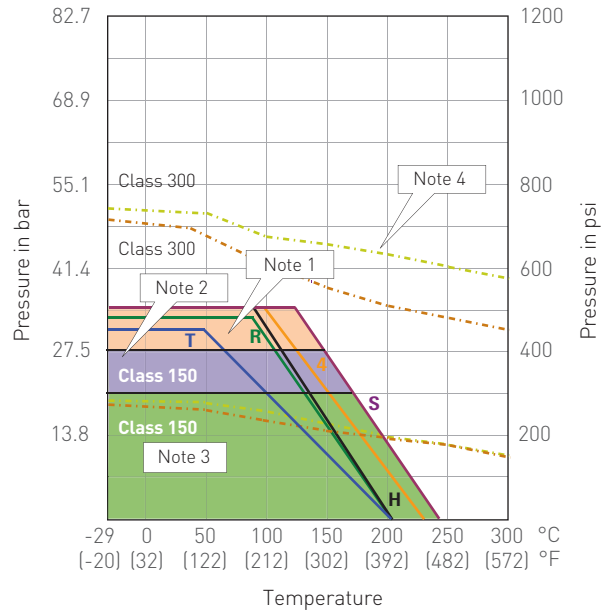

- = Body material 1.0619 body rating
- = Body material 1.4408 body rating
- = WCB body rating
- = CF8M body rating
- T = PTFE
- R = RPTFE
- 4 = 25% carbon filled PTFE
- S = 50% SS filled PTFE
- U = UHMWP
- K = PEEK (450G)
- H = TFM 1600

**NOTES:**

1. NPS 5 & 6 maximum operation pressure 34.5 bar (500 psig).
2. NPS 8 & 10 maximum operation pressure 27.6 bar (400 psig).  
Please consult factory for this range of application.
3. NPS 12 maximum operation pressure 20.7 bar (300 psig).
4. 50% SS filled PTFE and 25% carbon filled PTFE shall not exceed this rating line for ANSI Class 300.



# KTM BALL VALVES FOR INDUSTRIAL AND PROCESS APPLICATIONS

## F190/F190F - PRESSURE/TEMPERATURE CHARTS

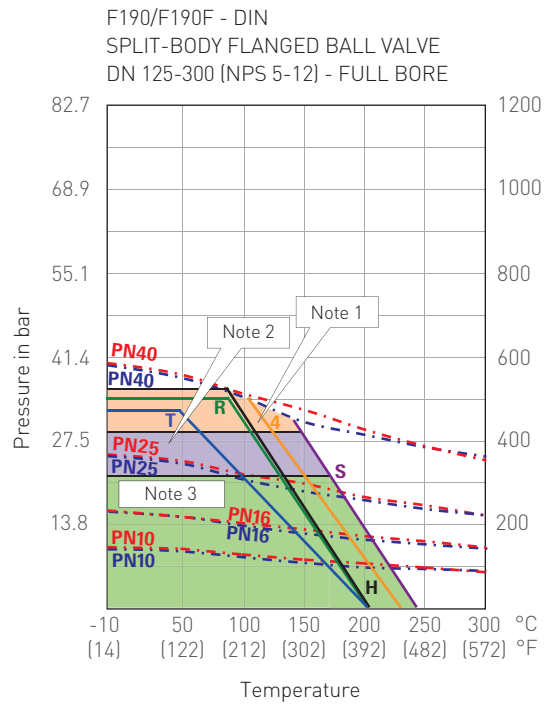
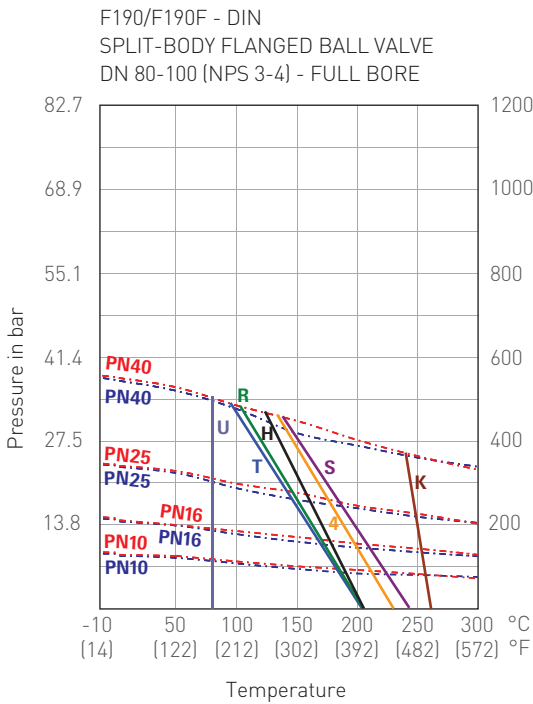
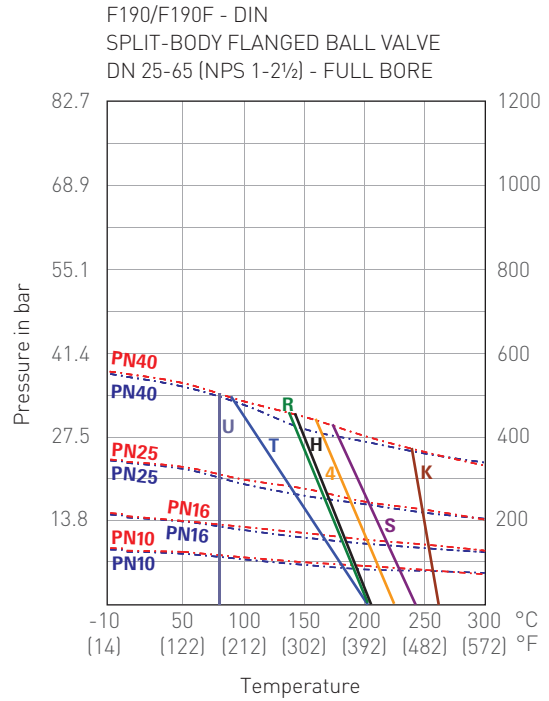
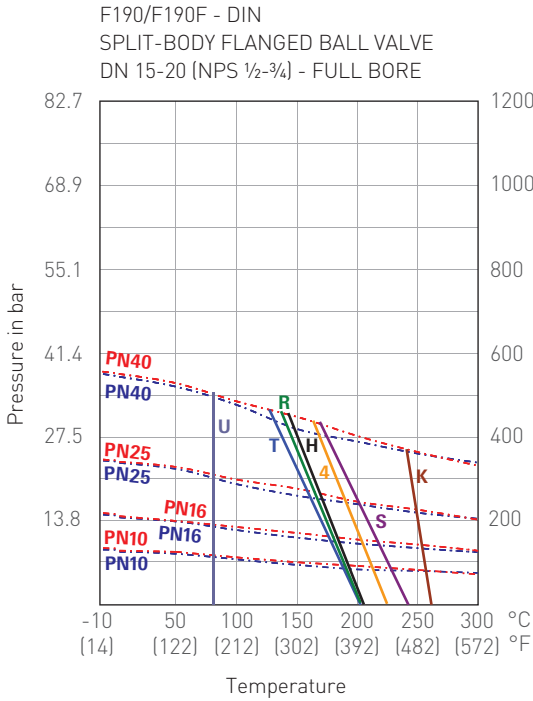

- - - - = Body material 1.0619 body rating
- · - · = Body material 1.4408 body rating
- · - · = WCB body rating
- · - · = CF8M body rating
- T = PTFE
- R = RPTFE
- 4 = 25% carbon filled PTFE
- S = 50% SS filled PTFE
- U = UHMWP
- K = PEEK (450G)
- H = TFM 1600

### NOTES:

1. DN 125 & 150 maximum operation pressure 34.5 bar (500 psig).
2. DN 200 & 250 maximum operation pressure 27.6 bar (400 psig).  
Please consult factory for this range of application.
3. DN 300 maximum operation pressure 20.7 bar (300 psig).

Neither Emerson, Emerson Automation Solutions, nor any of their affiliated entities assumes responsibility for the selection, use or maintenance of any product. Responsibility for proper selection, use, and maintenance of any product remains solely with the purchaser and end user.

Emerson Automation Solutions, Emerson and the Emerson logo are trademarks and service marks of Emerson Electric Co. All other marks are the property of their respective owners.

The contents of this publication are presented for informational purposes only, and while every effort has been made to ensure their accuracy, they are not to be construed as warranties or guarantees, express or implied, regarding the products or services described herein or their use or applicability. All sales are governed by our terms and conditions, which are available upon request. We reserve the right to modify or improve the designs or specifications of such products at any time without notice.

[Emerson.com/FinalControl](https://www.emerson.com/FinalControl)

---