

**NEOTECHA SAPRO<sup>®</sup> IN-LINE AND TANK SAMPLING**

Sapro aseptic in-line and tank sampling systems offer sample isolation from the environment and personnel



**FEATURES**

- Aseptic/cleanable design, all wetted parts can be reached with steam, cleaning solvents or inert gas.
- Ability to totally contain sample, offering ultimate purity of sample in aseptic applications, and offers ultimate safety to personnel in toxic chemical applications.
- Simple and safe operation due to the use of a spring return manual lever. The lever automatically closes the sampler when it is released.
- 'True representative sample' every time without process interruption.
- Spring housing is totally sealed from the media.
- Valve is self draining (dead spot free).
- The bottle adaptor is provided with a two step disconnect to allow rinsing, cleaning and sterilizing all internal parts.
- The area between the primary and secondary spindle seal can be filled with alcohol to allow monitoring the stem seal and to avoid contamination.
- Solves the common problems of:
  - Sample isolation from environment
  - Sample isolation from personnel
  - Excellent cleaning of all wetted/exposed areas.

**GENERAL APPLICATIONS**

In industries like food, beverage, pharmaceutical, and biotechnology the sample must remain isolated from the environment during the sample taking process. Equipment used in the sample taking process is generally the largest source of cross contamination. This is due to the fact that the sampling equipment either cannot be completely cleaned, or cannot be cleaned in the proper sequence needed to maintain the integrity of the sample as well as process isolation.

**TECHNICAL DATA**

Pressure (bar):	0,1 to 10
Temperature (°C):	-10 to +160
Bottle connection:	ISO GL45
For use with bottles (ml):	100 to 2000
Size I-clamp:	3" Cherry Burrell
Size Tri-clamp:	2½"

## DESCRIPTION OF OPERATION

1. Remove blind plug from valve bayonet connector.
2. Insert complete adapter with bottle into bayonet connector on valve body and turn it to Pos. 1.
3. Open steam valve on side of sampling valve body. The seat area between the valve and the check valve in the bottle adapter is being sterilized.
4. After required sterilizing process is completed, close steam valve. Wait for approximately 20 seconds.
5. Turn bottle adapter to Pos. 2.
6. The sample can now be taken by turning the handle. The flow of the product can be adjusted by the set screw on top of the bayonet.
7. Release handle when sufficient sample is in the bottle.
8. Insert locking pin to lock valve in the closed position.
9. Turn bottle adapter back to Pos. 1.
10. Open water rinse valve on side of the valve body.
11. After 5-10 seconds of rinsing, close rinse valve.
12. Disconnect bottle adapter from valve body and attach the blind plug to the valve.
13. Take bottle adapter and bottle with sample to laboratory.
14. Unscrew bottle from bottle adapter in a sterile environment.
15. Remove sample from bottle.
16. For next sample, repeat entire process above.

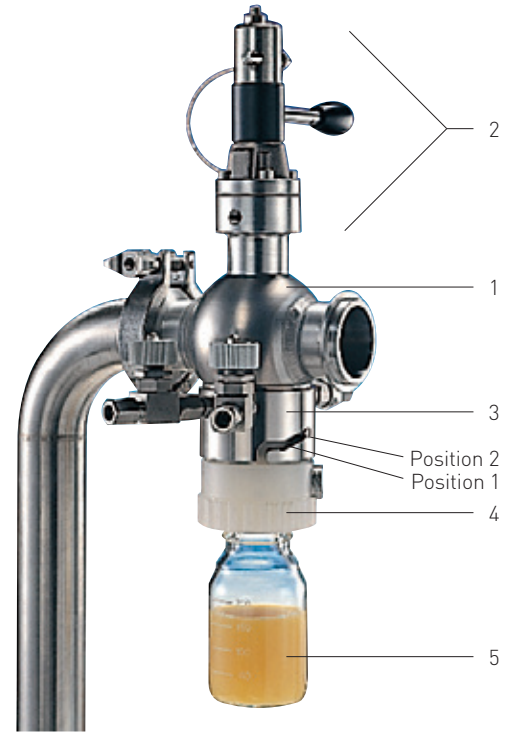

## MAIN COMPONENTS

1. Valve body
2. Bonnet, lever operator
3. Bottle connector with steam and rinse valve
4. Bottle adapter with integrated check valve and ISO GL45 bottle thread
5. Glass bottle, plastic coated, 250 ml.

All wetted parts are 316L Stainless steel, PVDF, and/or borosilicate glass. Seat seals are available in FPM, Peek, perfluoroelastomer or PTFE to meet customers' service requirements. The valve is available with I-Line or Tri-clamp end connections. Also, ANSI class 150 or 300 flanges can be supplied upon request.

## DIMENSIONS mm/inch

Size	A	B	C	D
25/1"	432/17.00"	117/4.60"	199/7.85"	106.1/4.18"
40/1-1/2"	445/17.50"	123/4.85"	206/8.15"	117.0/4.61"
50/2"	457/18.00"	130/5.10"	212/8.35"	141.3/5.36"
65/2-1/2"	470/18.50"	136/5.35"	220/8.65"	191.0/7.52"
80/3"	483/19.00"	142/5.60"	225/8.85"	177.8/7.00"
100/4"	508/20.00"	180/7.10"	225/8.85"	197.0/7.75"

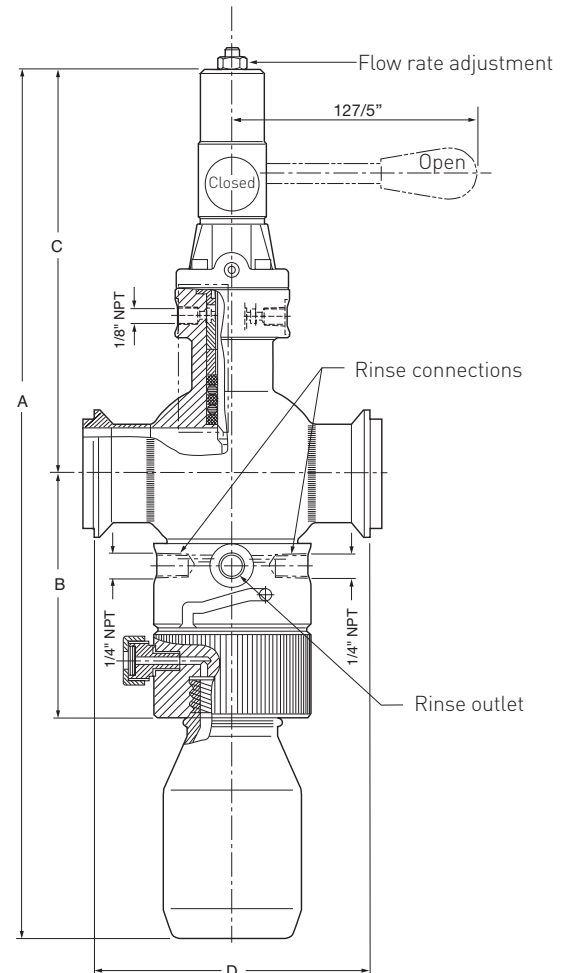

## GENERAL FEATURES

- Aseptic/cleanable design, all wetted parts can be reached with steam, cleaning solvents or inert gas.
- Ability to totally contain sample, offering ultimate purity of sample in aseptic applications, and offers ultimate safety to personnel in toxic chemical applications.
- Simple and safe operation due to the use of a spring return manual lever. This spring loaded lever automatically closes the sampler when it is released.
- The Sapro sampling system assures a 'true representative sample' every time without process interruption.
- Spring housing is totally sealed from the media.
- Valve is self draining (dead spot free).
- The bottle adaptor is provided with a two step disconnect to allow rinsing, cleaning and sterilizing all internal parts.
- The area between the primary and secondary spindle seal can be filled with alcohol to allow monitoring the stem seal and to avoid contamination.
- Solves the common problems of:
  - Sample isolation from environment
  - Sample isolation from personnel
  - Excellent cleaning of all wetted/exposed areas.

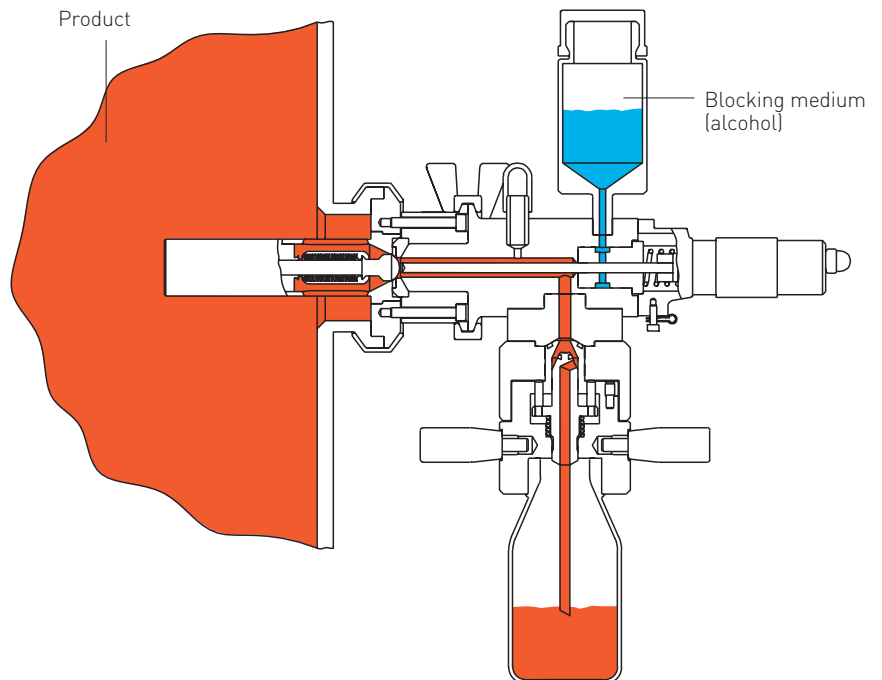

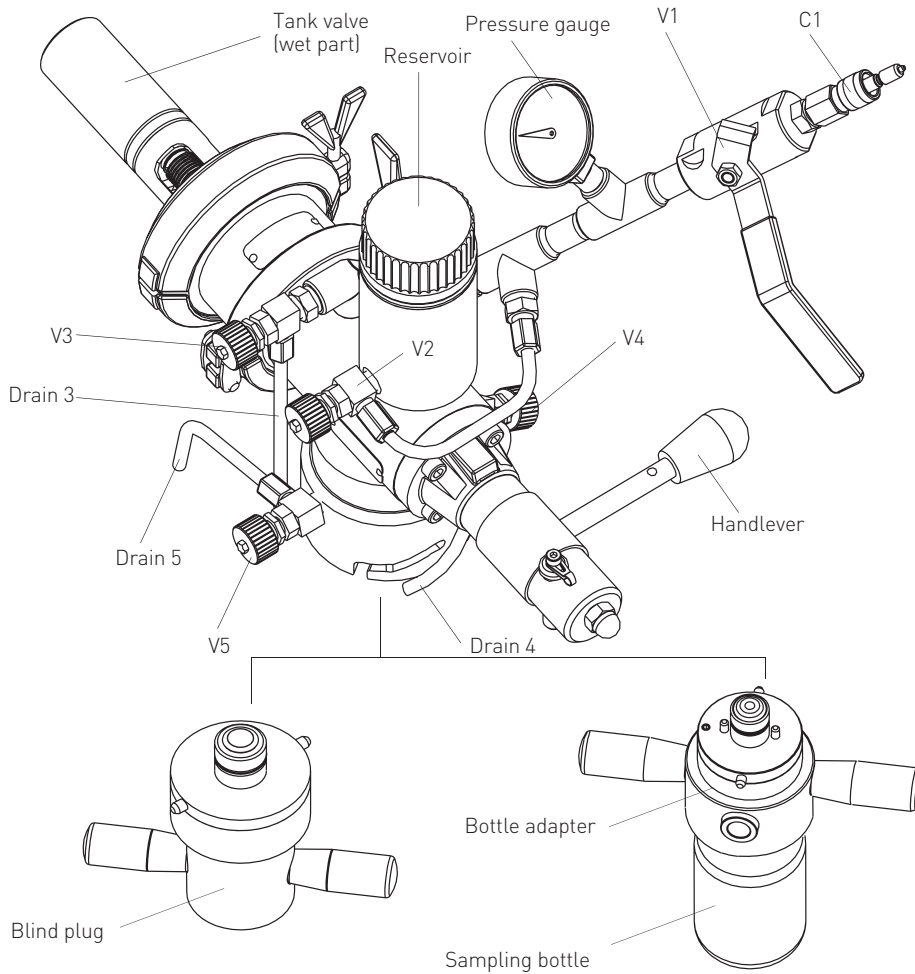

**CONNECTIONS AND VALVES**

**C1:** Customer connection (Swagelok 1/8" for:

- a. Steam inlet to sterilize the sample passage in the body and bottle adapter.
- b. Inlet for any cleaning liquids before taking samples, depending on the medium to sample.

**V1:** Ball valve to control the inlet of the customer connection C1.

**V2:** By opening this valve the alcohol from the reservoir fills the inner part of the tank valve body.

**V3:** Drain valve to control the filling of the tank valve body from the reservoir when no samples are taken. The body is only filled entirely when the alcohol flows through this valve down drain 3.

**V4:** Drain valve for stem blocking media. By taking an alcohol sample at this point the state of blocking media and the stem seal can be monitored.

**V5:** Actuator drain valve. Prior to sterilizing the sample passage this valve must be opened and closed again when sterilizing process is completed.

**Reservoir:**

The purpose of the reservoir is to ensure a constant head of blocking media (alcohol) around the operator stem.

**Bottle adapter:**

Aseptic sampling adapter for bottles with ISO GL45.

**Pressure gauge:**

Pressure gauge to control the pressure coming from the customer connection C1.