

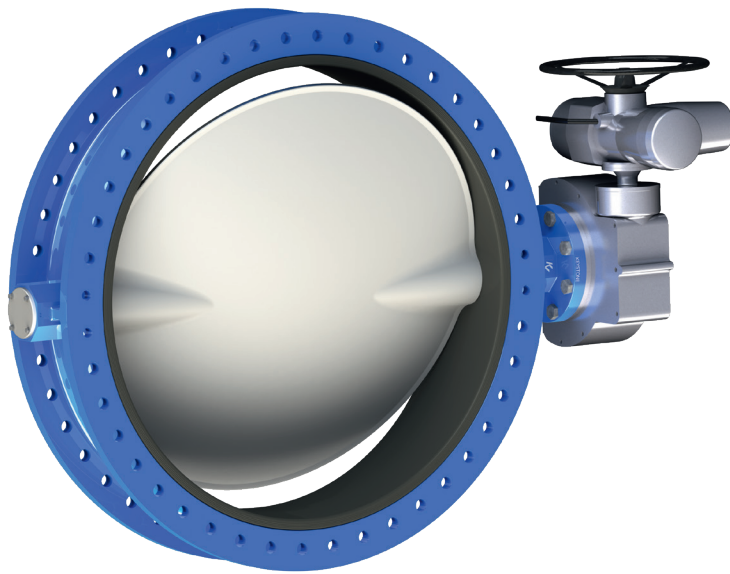

## KEYSTONE SERIES GRF RESILIENT SEATED BUTTERFLY VALVES

A heavy duty double flanged concentric design resilient seated butterfly valve



### FEATURES

- Double flanged body design with face-to-face dimensions, according to EN 558 Series 20, API 609 and AWWA C504 short.
- Designed according to EN 593 and API 609.
- The seat is field replaceable and fully isolates the body and shaft from the flow.
- Primary shaft sealing exceeds the pressure rating of the valve and prevents leakage through shaft area to atmosphere.
- A secondary shaft sealing provides back-up safety.
- A molded-in O-ring in the seat for flange sealing eliminates the need for gaskets.
- Shaft seals prevent moisture penetrating into the shaft area.
- Rounded polished disc edge gives full concentric sealing, lower torques, longer seat life and drop-tight shut-off.
- Extended body neck allows for pipe insulation.
- Actuator flange according to ISO 5211.
- Top and bottom shaft bearings for optimized support and minimum friction and decreased torque.
- Top bushing absorbs actuator side thrust loads.
- All valves comply to Pressure Equipment Directive (97/23/EU) Module B1 + D, CE Marking.
- Available approvals: ABS, NSF/ANSI STD 61.

### GENERAL APPLICATION

These valves are for water or air service where a drop-tight shut-off and double flanged body are required.

### TECHNICAL DATA

Sizes:	DN 600 - 1800
Pressure:	10 bar DN 600 - 1800
End of line:	6 bar DN 600 - 1800
Vacuum service:	0.4 bar
Temperature:	-40°C to +160°C
Flange accommodation:	PN 10 ASME 125/150 AWWA C207 Table B/D/E JIS 10K AS4087 PN 16 AS2129 Table D/E
Flange facing:	Flat face (standard) Raised face (option)

# KEYSTONE SERIES GRF RESILIENT SEATED BUTTERFLY VALVES

DN 600-1000

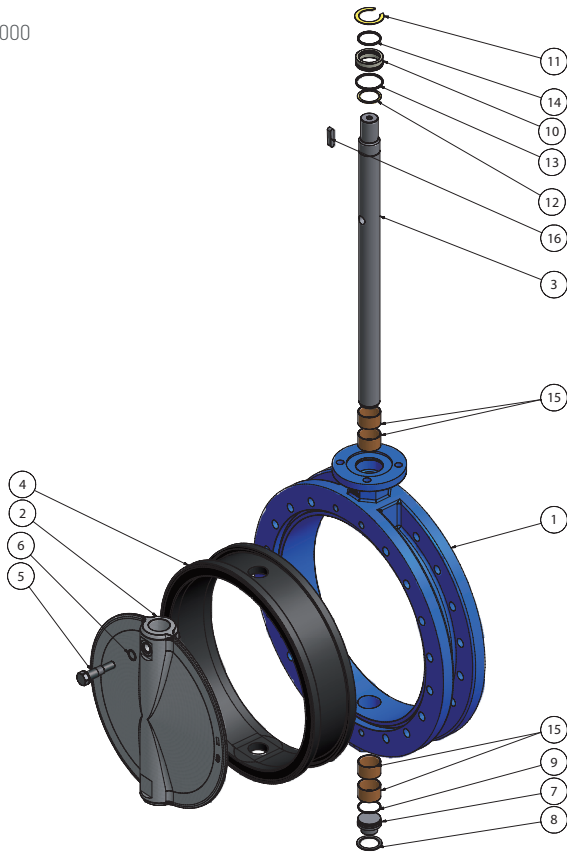

## PARTS LIST

Item	Description	Qty
1	Body	1
2	Disc	1
3	Shaft	1
4	Seat	1
5	Disc screw	1
6	Disc screw O-ring	1
7	Plug	1
8	Plug circlip	1
9	Plug O-ring	1
10	Bushing	1
11	Body circlip	1
12	Shaft circlip	1
13	Body O-ring	1
14	Shaft O-ring	1
15	Bearing	4
16	Parallel key	1

## MATERIAL SPECIFICATION

Part name	Material	Designation	EN/DIN mat.no	Remark
Body	Ductile iron	GJS-400-15	EN JS-1030	Dual certified to ASTM A536-65-45-12
	Ductile iron	GJS-400-18	EN 5.3103	Dual certified to ASTM A395 60/40/18
	Carbon steel	GP240GH	EN 1.0619	
	Stainless steel	GX5CrNiMo19-11-2	EN 1.4408	
Disc	316 stainless steel	GX5CrNiMo19-11-2	EN 1.4408	Comparable with CF8M
	304 stainless steel	GX5CrNiMo19-10	EN 1.4308	Comparable with CF8
	Duplex	GX2CrNiMoN22-5-3	EN 1.4470	
	Aluminium bronze	CuAl10Fe2-C	EN CC331G	
	Nickel aluminium bronze	CuAl10Fe5Ni5	EN CC333G	Comparable with BS 1400 AB2
	Ductile iron epoxy CTD	GJS-400-15	EN JS-1030	Max. temp. 120°C
	Ductile iron nylon CTD			Max. temp. 60°C
	Ductile iron FBE CTD			Max. temp. 52°C FBE - Fusion bond epoxy
Ductile iron ebonite lined			Max. temp. 100°C	
Shaft	431 stainless steel	X17CrNi16-2	EN 1.4057	Similar to ASTM A276/Gr. 431
	Duplex	X2CrNiMoN22-5-3	EN 1.4462	
	Super duplex	X2CrNiMoN25-7-4	EN 1.4410	
	K500 Monel®	DIN 17752	EN 2.4375	
Seat	EPDM			Food grade
	NBR			Food grade
	Fluoroelastomer (FKM)			
Disc screw	Duplex	X2CrNiMoN22-5-3	EN 1.4462	
Disc screw O-ring	EPDM			
	NBR			
	Fluoroelastomer (FKM)			
Plug	Carbon steel			
Plug circlip	Stainless steel			
Plug O-ring	NBR			
Bushing	Polyester			
Shaft/Body circlip	Stainless steel			
Shaft/Body O-ring	NBR			
Bearing	PTFE/steel			

# KEYSTONE SERIES GRF RESILIENT SEATED BUTTERFLY VALVES

DN 1050-1800

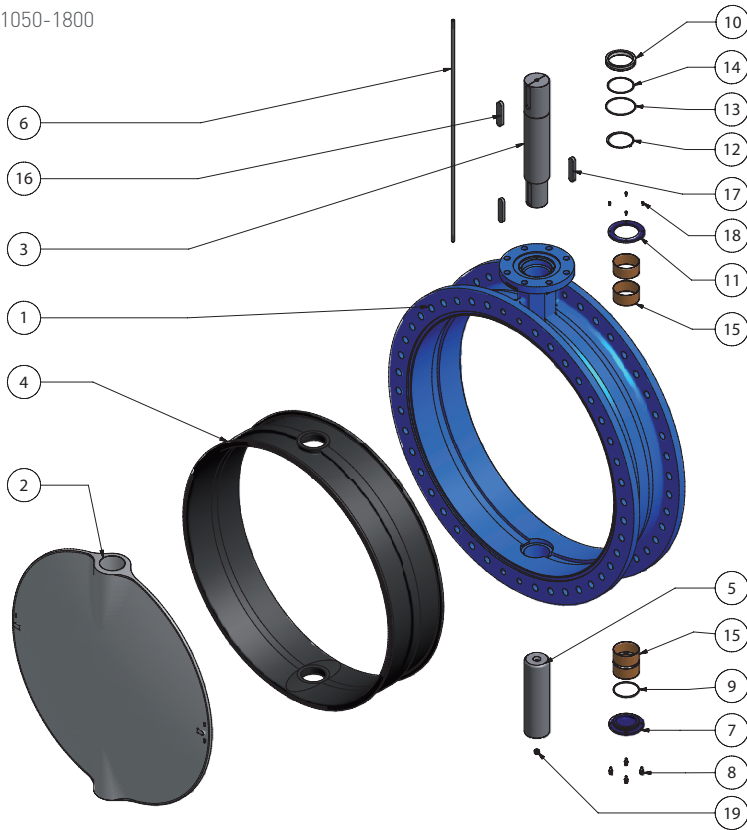

## PARTS LIST

Item	Description	Qty
1	Body	1
2	Disc	1
3	Shaft	1
4	Seat	1
5	Bottom shaft	1
6	Through bolt	1
7	Bottom cover	1
8	Bottom cover screw	4
9	Bottom cover O-ring	1
10	Bushing	1
11	Bushing cover	1
12	Shaft circlip	1
13	Body O-ring	1
14	Shaft O-ring	1
15	Bearing	4
16	Parallel key	1
17	Parallel key disc shaft	2
18	Bushing cover screw	4
19	Lock nut	1

## MATERIAL SPECIFICATION

Part name	Material	Designation	EN/DIN mat.no	Remark
Body	Ductile iron	GJS-400-15	EN JS-1030	Dual certified to ASTM A536-65-45-12
	Ductile iron	GJS-400-18	EN 5.3103	Dual certified to ASTM A395 60/40/18
	Carbon steel	GP240GH	EN 1.0619	
	Stainless steel	GX5CrNiMo19-11-2	EN 1.4408	
Disc	316 stainless steel	GX5CrNiMo19-11-2	EN 1.4408	Comparable with CF8M
	304 stainless steel	GX5CrNiMo19-10	EN 1.4308	Comparable with CF8
	Duplex	GX2CrNiMoN22-5-3	EN 1.4470	
	Aluminium bronze	CuAl10Fe2-C	EN CC331G	
	Nickel aluminium bronze	CuAl10Fe5Ni5	EN CC333G	Comparable with BS 1400 AB2
	Ductile iron epoxy CTD	GJS-400-15	EN JS-1030	Max. temp. 120°C
	Ductile iron nylon CTD			Max. temp. 60°C
	Ductile iron FBE CTD			Max. temp. 52°C FBE - Fusion bond epoxy
Ductile iron ebonite lined			Max. temp. 100°C	
Shaft	431 stainless steel	X17CrNi16-2	EN 1.4057	Similar to ASTM A276/Gr. 431
	Duplex	X2CrNiMoN22-5-3	EN 1.4462	
	Super duplex	X2CrNiMoN25-7-4	EN 1.4410	(optional)
	K500 Monel®	DIN 17752	EN 2.4375	
Seat	EPDM			Food grade
	NBR			Food grade
Through bolt	Stainless steel			
Bottom cover	Ductile iron	GJS-400-15	EN JS-1030	
Bottom cover screw	Steel class 8.8 - Zinc plated/coated			
Bottom cover O-ring	NBR			
Bushing	Polyester			
Bushing cover	Steel			
Shaft circlip	Stainless steel			
Shaft/Body O-ring	NBR			
Bearing	PTFE/steel			
Bushing cover screw	Steel class 8.8 - Zinc plated/coated			
Lock nut	Steel class 8 - Zinc plated/coated			

# KEYSTONE SERIES GRF RESILIENT SEATED BUTTERFLY VALVES

DN 600-1000

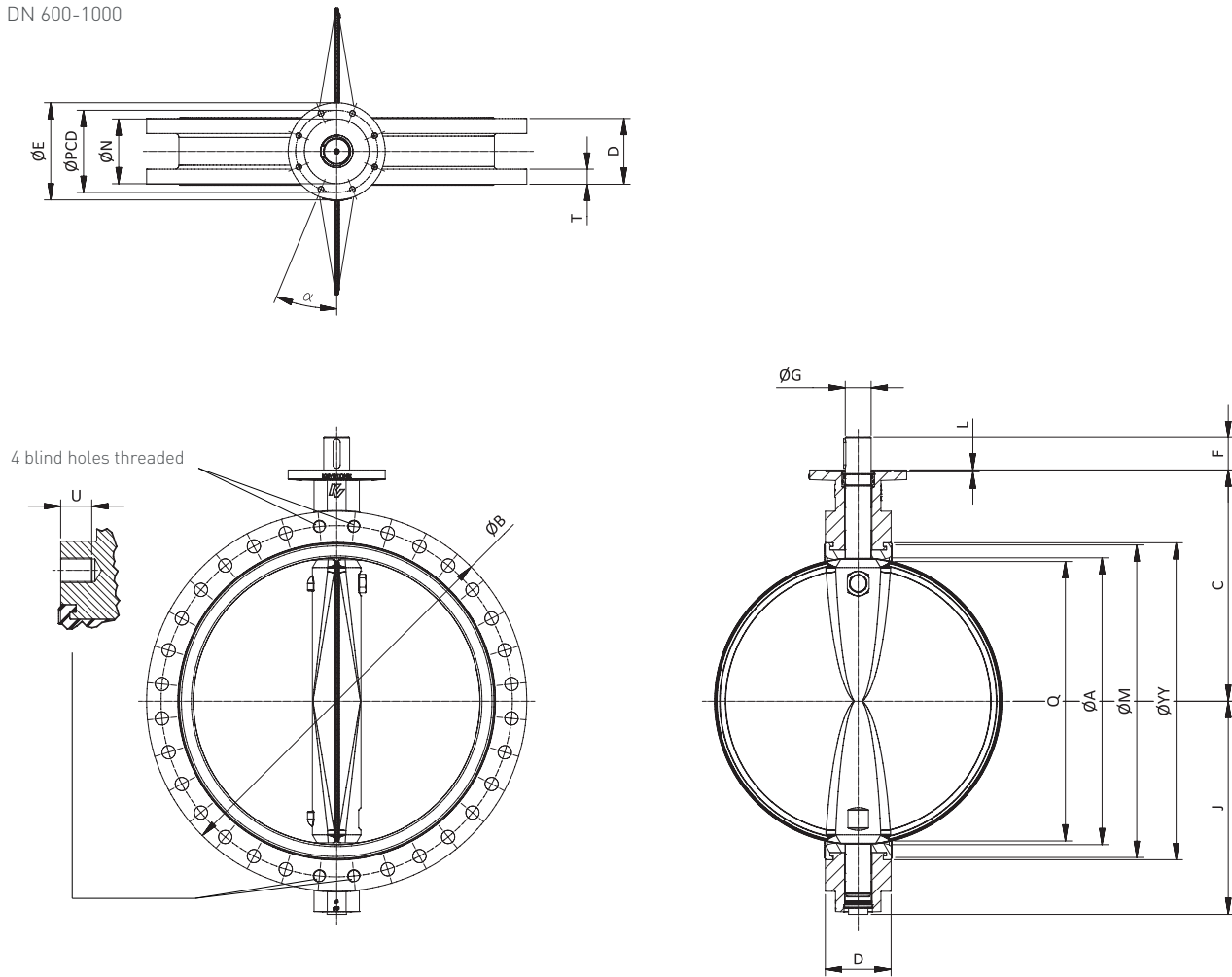

## VALVE DIMENSIONS (mm)

Size (DN)	Valve Body Dimensions													Shaft		Top plate drilling				Adapt. code	Weight (kg) <sup>(2)</sup>	
	A	B	C	D	E	F	J	L	M	N	Q <sup>(1)</sup>	T	YY	G	Key	Bolt circle	No. holes	Holes dia.	U <sup>(4)</sup>			
600	585	825	500	154	210	70	456	6	651	130	569	41	670	60	18 x 11	165	4	45°	22	40	F16	227
700	684	925	570	165	210	80	518	6	754	130	669	38	775	70	20 x 12	165	4	45°	22	40	F16	293
750	734	995	605	190 <sup>(3)</sup>	210	90	551	6	810	130	714	43	835	70	20 x 12	165	4	45°	22	40	F16	360
800	784	1060	640	190	300	90	583	6	857	200	767	43	880	70	20 x 12	254	8	22.5°	17.5	48	F25	430
900	884	1175	715	203	300	100	659	6	957	200	867	47	980	80	22 x 14	254	8	22.5°	17.5	48	F25	552
1000	984	1290	780	216	350	129	706	6	1057	230	968	50	1081	90	25 x 14	298	8	22.5°	22	48	F30	732

## NOTES

1. 'Q' dimension is the minimum allowable pipe or flange inside diameter at the centered body face to protect the disc sealing edge against damage when opening the valve.
2. Weight may vary depending on trim materials used.
3. EN 558 standard allows for both 165 and 190 mm face to face on DN 750. FTF of 190 mm is standard with 165 mm FTF as an option. Consult factory for availability.
4. Tap depth.
5. See installation, operation and maintenance manual (IOM) for detailed bolting information.

# KEYSTONE SERIES GRF RESILIENT SEATED BUTTERFLY VALVES

DN 1050-1800

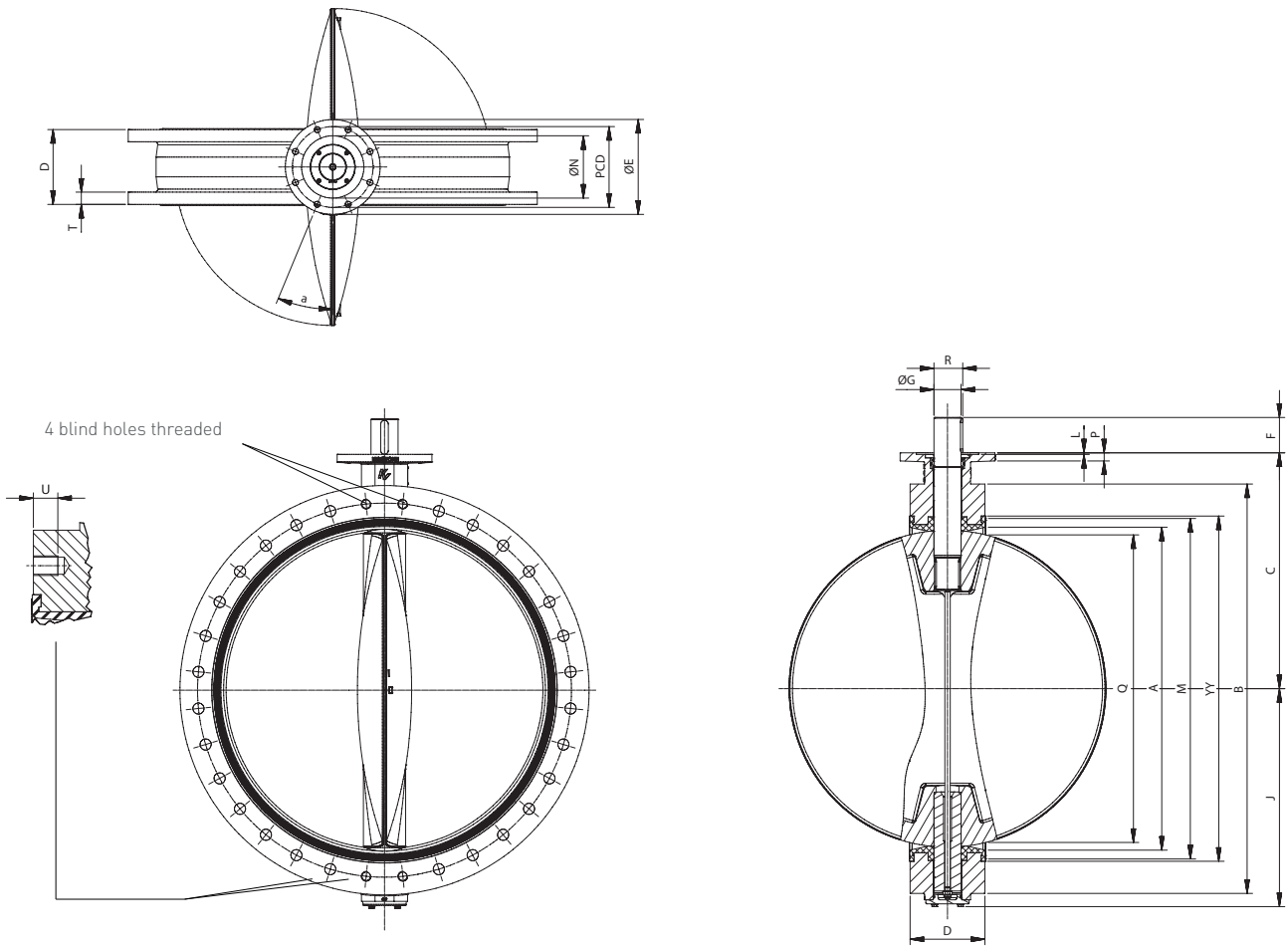

## VALVE DIMENSIONS (mm)

Size (DN)																Shaft			Top plate drilling				Adapt. W <sup>(2)</sup>		
	A	B	C	D	E	F	J	L	M	N	P	Q <sup>(1)</sup>	R	T	YY	G	Key	Key L	Bolt circle	No. holes	a	Holes dia.	U <sup>(3)</sup>	code	(kg)
1050	1060	1345	780	251	350	115	745	6	1132	230	30	1015	95	42.5	1149.5	90	25 x 14	110	298	8	22.5	22	42.5	F30	735
1100	1083	1405	815	254	350	115	777	6	1155	230	30	1038	106	42.5	1172.5	100	28 x 16	110	298	8	22.5	22	42.5	F30	855
1200	1184	1510	870	276	350	130	845	6	1256	230	30	1137	106	45	1273.5	100	28 x 16	125	298	8	22.5	22	45	F30	1025
1350	1327	1685	975	381	415	165	895	6	1399	260	45	1256	106	46	1416.5	100	28 x 16	160	356	8	22.5	33	46	F35	1406
1400	1381	1745	1010	280	415	165	918	6	1453	260	45	1338	117	46	1470.5	110	28 x 16	160	356	8	22.5	33	46	F35	1421
1500	1482	1855	1080	381	415	165	989	6	1554	260	45	1417	138	47.5	1571.5	130	32 x 18	160	356	8	22.5	33	47.5	F35	1786
1600	1591	1910	1150	318	415	165	1038	6	1663	260	45	1544	148	49	1680.5	140	36 x 20	160	356	8	22.5	33	49	F35	1863
1650	1664	2032	1185	457	415	165	1082	6	1736	260	45	1585	148	50	1753.5	140	36 x 20	160	356	8	22.5	33	50	F35	2243
1800	1785	2195	1290	457	475	185	1209	9	1857	300	54	1711	169	52	1874.5	160	40 x 22	180	406	8	22.5	39	52	F40	2828

## NOTES

1. 'Q' dimension is the minimum allowable pipe or flange inside diameter at the centered body face to protect the disc sealing edge against damage when opening the valve.
2. Weight may vary depending on trim materials used.
3. Tap depth.
4. See installation, operation and maintenance manual (IOM) for detailed bolting information.

# KEYSTONE SERIES GRF RESILIENT SEATED BUTTERFLY VALVES

## TORQUE APPLICATION FACTOR CATEGORIES

### Application I

Clean liquid lubricating media (water, clean oils, lube oil, mineral oil, etc.); and with no deposit or chemical attack, valve operated at least once a week. Temperature range from 0°C to maximum temperature rating of the elastomer seat.

### Application II

Other liquid media and lubricating gases (aqueous liquids, such as food & beverage, water, etc.); and with minor deposit or chemical attack, valve operated at least once a month. Temperature range from 0°C to maximum temperature rating of the elastomer seat.

### Application III

- a. Dry non-abrasive media or gases (non-abrasive powders and dry gas); or
- b. Fluids with moderate deposit or chemical attack; or
- c. Valves operated less than once a month.

Temperature range from 0°C to maximum temperature rating of the elastomer seat.

### Application IV

- a. Dry abrasive media and degreasing applications (sand, cement, silicone free, oxygen cleaned); or
- b. Liquids with severe deposit; or
- c. Valves not frequently operated (once a year).

All above with temperature range from -10°C to maximum temperature rating of the elastomer seat.

## NOTES

1. For applications with temperatures above or below the guidelines above, please consult factory.
2. For dry service valves it is suggested to use U/C discs (reduced diameter) when service conditions are less than 3.5 bar.

## VALVE SEATING AND UNSEATING TORQUES (Nm)

Application ΔP (bar)	Valve size (DN)														
	600	700	750	800	900	1000	1050	1100	1200	1350	1400	1500	1600	1650	1800
<b>I</b>															
3.5	1700	2494	2967	3495	4422	5831	6428	7505	8931	11982	12885	16469	19692	20942	27338
7	1979	2943	3521	4169	5275	7022	7742	9114	10846	14657	15762	20393	24511	26066	34331
10	2373	3575	4302 <sup>(1)</sup>	5120	6479	8704	9595	11385	13548	18433	19824	25935	31316	33304	44212
3.5 (U/C)	1020	1497	1780	2097	2653	3498	3857	4503	5359	7189	7731	9881	11815	12565	16403
<b>II</b>															
3.5	1877	2736	3245	3811	4822	6325	6973	8103	9643	12882	13854	17581	20957	22287	28938
7	2153	3180	3793	4479	5667	7506	8275	9699	11542	15538	16710	21481	25749	27383	35898
10	2542	3804	4565 <sup>(1)</sup>	5419	6858	9172	10111	11951	14222	19286	20741	26988	32514	34578	45728
3.5 (U/C)	1126	1642	1947	2287	2893	3795	4184	4862	5786	7729	8312	10548	12574	13372	17363
<b>III</b>															
3.5	2055	2978	3523	4127	5222	6819	7517	8701	10354	13782	14822	18692	22221	23632	30539
7	2328	3417	4065 <sup>(1)</sup>	4788	6059	7990	8808	10285	12239	16420	17658	22569	26987	28699	37465
10	2710	4034 <sup>(1)</sup>	4828 <sup>(1,2)</sup>	5719 <sup>(2)</sup>	7237	9640	10627	12518	14896	20139	21658	28041	33713	35852	47244
3.5 (U/C)	1233	1787	2114	2476	3133	4091	4510	5221	6212	8269	8893	11215	13333	14179	18323
<b>IV</b>															
3.5	2322	3341	3940	4601	5822	7560	8334	9598	11421	15133	16274	20359	24118	25649	32940
7	2589	3772	4473 <sup>(1)</sup>	5252	6646	8715	9608	11162	13283	17742	19080	24202	28844	30674	39815
10	2963	4378 <sup>(1)</sup>	5223 <sup>(1,2)</sup>	6168 <sup>(2)</sup>	7805	10342	11401	13367	15907	21418	23034	29621	35510	37763	49519
3.5 (U/C)	1393	2005	2364	2761	3493	4536	5001	5759	6853	9080	9765	12216	14471	15389	19764

## NOTES

3.5 U/C refers to reduced diameter disc option.

1. Use a minimum of Class 8.8 steel bolts to connect actuator to valve.
2. Duplex shaft not suitable for these conditions, use only 431 stainless steel or super duplex.

## MAXIMUM ALLOWABLE SHAFT TORQUES (Nm)

Shaft material	Valve size (DN)														
	600	700	750	800	900	1000	1050	1100	1200	1350	1400	1500	1600	1650	1800
431SS (SS 1.4057)	4455	6300	6300	7560	11424	18900	16065	19680	23280	34848	34848	44928	52080	52080	73920
Duplex (SS 1.4462)	3341	4725	4725	5670	8568	14175	12049	14760	17460	26136	26136	33696	39060	39060	55440
Super duplex (SS 1.4410)	3824	5408	5408	6489	9806	16233	13789	16892	19982	29911	29911	38563	44702	44702	63448
Monel K500 (ASTM B865 UNS N0500)	4239	5260	5907	5907	12283	15750	13388	16400	19400	26400	29040	37440	43400	43400	61600

# KEYSTONE SERIES GRF RESILIENT SEATED BUTTERFLY VALVES

## FLOWRATE CO-EFFICIENTS - K<sub>v</sub> VALUES

Size (DN)	Disc opening (degrees)								
	10°	20°	30°	40°	50°	60°	70°	80°	90°
600	349	894	1871	3357	5689	9140	14723	26357	30583
700	475	1216	2547	4569	7744	12440	20040	35875	41626
750	545	1396	2924	5245	8890	14281	23005	41183	47785
800	620	1589	3327	5968	10114	16248	26174	46857	54369
900	785	2011	4211	7553	12801	20564	33127	59303	68811
1000	969	2483	5197	9325	15803	25389	40897	73214	84953
1050	1068	2737	5732	10280	17423	27656	50010	85811	95862
1100	1172	3004	6290	11283	19122	30353	54886	94178	105209
1200	1395	3575	7486	13428	22757	36122	65319	112079	125208
1350	1766	4524	9475	16994	28802	45717	82670	141850	158466
1400	1899	4866	10189	18276	30975	49167	88907	152552	170422
1500	2180	5586	11697	20981	35558	56441	102061	175124	195637
1600	2480	6355	13309	23871	40457	64218	116123	199252	222591
1650	2638	6759	14153	25386	43025	68294	123494	211900	236721
1800	3139	8043	16844	30212	51204	81275	146968	252178	281717

### NOTE

K<sub>v</sub> = The volume of water in m<sup>3</sup>/hr that will pass through a valve with a pressure drop of 1 bar at 20°C

## PRESSURE-TEMPERATURE DIAGRAM

Seat material*	Body material	Disc material**	Size range (DN)	Vacuum (bar absolute)	Temperature (°C)							
					-40	-28	-20	-15	0	50	100	130
EPDM - FG - HT	DI A536 65-45-12 CS A216 WCB SS A351 CF8M	All	1000-1800	Consult factory	<div style="display: flex; justify-content: space-around; align-items: center;"> <div style="border: 1px solid black; padding: 5px;">Non-PED</div> <div style="border: 1px solid black; padding: 5px;">10 bar / 6 bar</div> </div>							
EPDM - FG - HT	DI A395 60-40-18	Note the following temperature limits: Nylon max. 60°C Epoxy max. 120°C FBE max. 52°C Ebonite max. 100°C	1000-1800									
NBR and White NBR	All		1000-1800									
FKM	All		1000-1800									
EPDM - FG - HT (Bonded)	All		1000-1800									
NBR (Bonded)	All		1000-1800									

\* All seat materials drop tight

\*\* Per material listed in the material specification tables

# KEYSTONE SERIES GRF RESILIENT SEATED BUTTERFLY VALVES

## TEMPERATURE PERFORMANCE COATED DISC

Disc material	Coating	Size range (DN)	°C
GJS400-15 / GJS400-18	DI epoxy coated	600-1800	-28 to 120 / -40 to 120
GJS400-15 / GJS400-18	DI nylon coated	600-1800	-28 to 60 / -40 to 60
GJS400-15 / GJS400-18	DI FBE coated	600-1800	-28 to 52 / -40 to 52
GJS400-15 / GJS400-18	DI ebonite coated	600-1800	-28 to 100 / -40 to 100

## POSSIBLE FLANGE DRILLINGS

Flange drilling	Valve size (DN)														
	600	700	750	800	900	1000	1050	1100	1200	1350	1400	1500	1600	1650	1800
EN 1092 PN 10			N/A				N/A			N/A		N/A		N/A	
ISO 2084 PN 10							N/A			N/A					N/A
ASME B16.5 Class 150	See B16.47A														
ASME B16.1 Class 125		N/A		N/A		N/A		N/A			N/A			N/A	
ASME B16.47A Class 150	See B16.5														N/A
AWWA C207 Table B/D/E											N/A		N/A		
MSS SP44 Class 150															N/A
ASME B16.47B Class 150		N/A			0	0	N/A	0	0	0	0	0	0	0	N/A
JIS B2210 10K							N/A				N/A				N/A
JIS B2210 5K			0	0	0	0	N/A	0	0	0	N/A	0			N/A
AS2129 Table D							N/A			N/A		N/A		N/A	
AS4087 PN 16							N/A			N/A		N/A		N/A	
AS2129 Table E							N/A			N/A					

### NOTES

	Standard possible for all versions
0	Optional, contact factory

N/A Not applicable

Data is valid for flat face flanges. For raised face, please consult factory

See installation, operation and maintenance manual (IOM) for detailed bolting information.



# KEYSTONE SERIES GRF RESILIENT SEATED BUTTERFLY VALVES

## SELECTION GUIDE

Example:	GRF	0900	- D0	S1	S2	E0	A1	I	- 00	000	00
<b>Body style</b>											
<b>GRF</b>	Double flanged										
<b>Size</b>											
<b>0600</b>	DN 600/NPS 24			<b>1200</b>	DN 1200/NPS 48						
<b>0700</b>	DN 700/NPS 28			<b>1350</b>	DN 1350/NPS 54						
<b>0750</b>	DN 750/NPS 30			<b>1400</b>	DN 1400/NPS 56						
<b>0800</b>	DN 800/NPS 32			<b>1500</b>	DN 1500/NPS 60						
<b>0900</b>	DN 900/NPS 36			<b>1600</b>	DN 1600/NPS 64						
<b>1000</b>	DN 1000/NPS 40			<b>1650</b>	DN 1650/NPS 66						
<b>1050</b>	DN 1050/NPS 42			<b>1800</b>	DN 1800/NPS 72						
<b>1100</b>	DN 1100/NPS 44										
<b>Body</b>											
<b>D0</b>	Ductile iron GLS-400-15		<b>C0</b>	Carbon steel							
<b>D2</b>	Ductile iron GJS-400-18		<b>S0</b>	316 stainless steel							
<b>Disc</b>											
<b>D1</b>	Ductile iron - epoxy		<b>S1</b>	304 stainless steel							
<b>D2</b>	Ductile iron - nylon		<b>A1</b>	Aluminum bronze							
<b>D3</b>	Ductile iron - FBE <sup>(2)</sup>		<b>N0</b>	Nickel aluminum bronze							
<b>D7</b>	Ductile iron - Ebonite		<b>U0</b>	Duplex							
<b>S0</b>	316 stainless steel		<b>V0</b>	Super duplex							
<b>Shaft</b>											
<b>S2</b>	431 stainless steel		<b>V0</b>	Super duplex							
<b>U0</b>	Duplex		<b>M1</b>	Monel <sup>®</sup> K500							
<b>Seat</b>											
<b>E0</b>	EPDM (food grade)										
<b>N0</b>	NBR (food grade)										
<b>F1</b>	Fluoroelastomer FKM <sup>(1)</sup>										
<b>Flange drilling</b>											
<b>A1</b>	ASME 125/150		<b>J1</b>	JIS B2210 - 10K							
<b>A5</b>	AWWA C207		<b>P1</b>	ISO 7005 - PN 6							
<b>AE</b>	AS2129 table E		<b>P2</b>	ISO 7005 - PN 10							
<b>AD</b>	AS 4087 PN16/AS2129 table D										
<b>Actuator mounting</b>											
<b>I</b>	ISO mount										
<b>Actuation</b>											
<b>00</b>	None										
<b>G1</b>	Gear - blue										
<b>G5</b>	Chainwheel - blue										
<b>Special</b>											
<b>000</b>	None										
<b>P04</b>	Reduced disc for 50 psi										
<b>027</b>	Vacuum holes and fittings										
<b>Coating</b>											
<b>00</b>	Standard blue		<b>03</b>	C5M Keystone blue							
<b>02</b>	C3 Keystone blue		<b>04</b>	FBE coated body - blue							

## NOTES

- Fluoroelastomer (FKM) available in size up to DN 1000 only.
- FBE = Fusion bond epoxy.

Other options are available on request. Please consult your local sales representative. Monel<sup>®</sup> is a registered trademark of the Special Metals Corporation.

## KEYSTONE SERIES GRF RESILIENT SEATED BUTTERFLY VALVES

---

*This page intentionally left blank.*

## KEYSTONE SERIES GRF RESILIENT SEATED BUTTERFLY VALVES

---

*This page intentionally left blank.*

VCTDS-06275-EN © 2022 Emerson Electric Co. All rights reserved 12/22. Keystone is a mark owned by one of the companies in the Emerson Automation Solutions business unit of Emerson Electric Co. The Emerson logo is a trademark and service mark of Emerson Electric Co. All other marks are the property of their prospective owners.

The contents of this publication are presented for informational purposes only, and while every effort has been made to ensure their accuracy, they are not to be construed as warranties or guarantees, express or implied, regarding the products or services described herein or their use or applicability. All sales are governed by our terms and conditions, which are available upon request. We reserve the right to modify or improve the designs or specifications of such products at any time without notice.

Emerson Electric Co. does not assume responsibility for the selection, use or maintenance of any product. Responsibility for proper selection, use and maintenance of any Emerson Electric Co. product remains solely with the purchaser.

[Emerson.com/FinalControl](https://www.emerson.com/FinalControl)