

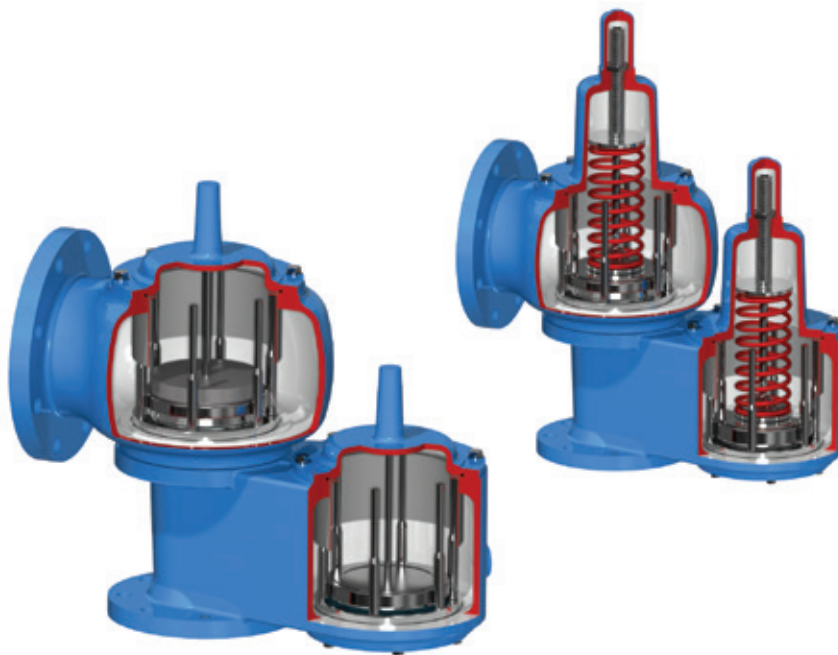

ANDERSON GREENWOOD TYPE 4040 PIPED AWAY PRESSURE AND VACUUM RELIEF VALVES

Weight or spring loaded valves capable of providing pressure and vacuum relief that pipe away to a closed header system. Designed to work closer to a tank's MAWP, increasing productivity, reducing emissions and product evaporation



FEATURES

- Increased flow capacities reduce the required valve size and the corresponding connections and piping costs.
- Fully open at 10% overpressure, enabling setting close to MAWP/MAWV and minimizing tank emissions.
- Large body for increased capacity providing high flow performance for full conformance to API2000/ISO28300.
- Leakage rate of 0.5 scfh (0.015 Nm³ /hr) or less at 90% of setpoint.
- Weight or spring loaded models available.
- Choice of body materials.
- Modular design enables all components to be removed and replaced in-situ for quicker, simpler maintenance.
- Optional 'all-weather' coating prevents frozen condensate build-up and sticking of vital components in cold weather applications.

GENERAL APPLICATION

Type 4040 valves allow tanks to work closer to their MAWP thus increasing productivity, reducing emissions and product evaporation. Increased flow capacities reduce the valve's size, corresponding connections and piping costs in applications for storage tank farms, oil and gas production, the petroleum, pharmaceutical and chemical sectors.

TECHNICAL DATA

Materials:	Aluminum, carbon steel, stainless steel
Sizes:	2" x 3" to 12" x 14" (DN 50 x 80 to DN 300 x 350)
Pressure settings	
Weight loaded:	up to 1.5 psig (100 mbarg)
Spring loaded:	up to 15 psig (1 barg)
Vacuum settings	
Weight loaded:	up to -1.5 psig (-100 mbarg)
Spring loaded:	up to -15 psig (-1 barg)
Certification:	ATEX 94/9 EC

ANDERSON GREENWOOD TYPE 4040 PIPED AWAY PRESSURE AND VACUUM RELIEF VALVES

MODELS OVERVIEW

Type 4040 valves are high capacity, full lift pressure and vacuum relief valves designed for use on atmospheric and low pressure storage tanks. Their primary function is to protect the tank from physical damage or permanent deformation caused by increases in internal pressure or vacuum encountered in normal operations. On smaller tanks, the valves may also provide sufficient flow capacity for emergency venting.

The valves are fully open at 10% overpressure allowing the user to have a quicker acting valve that can be set closer to the tank's maximum allowable working pressure, reducing emission losses. There are four pipe-away model variants:

Model 4040H offers weight-loaded pressure and vacuum relief.

Model 4040HP, spring-loaded pressure and weight-loaded vacuum relief.

Model 4040HC, spring-loaded pressure and vacuum relief.

Model 4040HV, weight-loaded pressure and spring-loaded vacuum relief.

APPLICATION

By controlling tank venting, Type 4040 pressure/vacuum valves not only minimize emissions to the environment but also the loss of product to evaporation. When combined with a well-designed vapor recovery system, the loss can be cut to essentially zero. Their 'air-cushion' seating design keeps the valve sealed tightly until the pressure inside the tank approaches the valve setting. The larger body allows for greater vacuum capacity in accordance with the most recent versions of tank vents sizing standards (API 2000/ISO 28300).

They offer the option of a non-frosting and icing-resistant coating on the pallet perimeter, stem, guide posts and seats which, along with the flexible PTFE seat insert, provides additional protection against pallets freezing closed.

TESTING

Each valve is tested for proper setting, for a leakage rate of less than 0.5 scfh (0.015 Nm³/hr) of air at 90% of the set point and for leak tightness at 75% of set point as required in API standard 2000.

SPECIFICATIONS

Available materials

- Aluminum with aluminum or stainless steel trim
- Carbon steel with stainless steel trim
- Stainless steel with stainless steel trim
- Special materials on application

Sizes, inches (DN)

- 2" x 3" (50 x 80)
- 3" x 4" (80 x 100)
- 4" x 6" (100 x 150)
- 6" x 8" (150 x 200)
- 8" x 10" (200 x 250)
- 10" x 12" (250 x 300)
- 12" x 14" (300 x 350)

Flanged connections –standard flange drilling

Aluminum body

Drilled to ANSI Class 150 dimensions (flat face)

Drilled to DIN 2633 (PN 16) dimensions (flat face)

CS and SS body

Drilled to ANSI Class 150 dimensions (raised or flat face)

Drilled to Imperial DIN 2633 (PN 16) dimensions (raised or flat face)

Options

- PTFE coated trim to minimize ice build-up
- Stainless steel weights
- Steam jackets
- Proximity sensors to monitor valve opening and closing

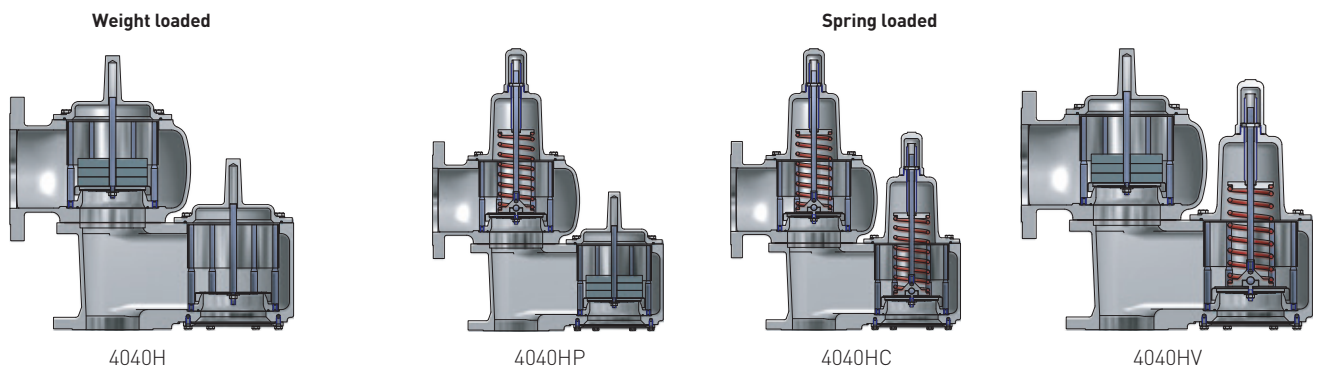

ANDERSON GREENWOOD TYPE 4040 PIPED AWAY PRESSURE AND VACUUM RELIEF VALVES

DIMENSIONS (mm)

4040H

Size		A	B	C	D	E
Inches	DN					
2	50	398	160	153	404	231
3	80	494	200	193	478	276
4	100	553	235	200	533	313
6	150	726	320	245	708	414
8	200	941	405	330	884	513
10	250	1158	500	410	1030	598
12	300	1358	590	480	1170	674

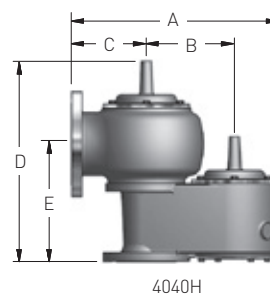

4040HP

Size		A	B	C	D	E
Inches	DN					
2	50	398	160	153	527	231
3	80	494	200	193	604	276
4	100	553	235	200	676	313
6	150	726	320	245	948	414
8	200	941	405	330	1215	513
10	250	1158	500	410	1474	598
12	300	1358	590	480	1710	674

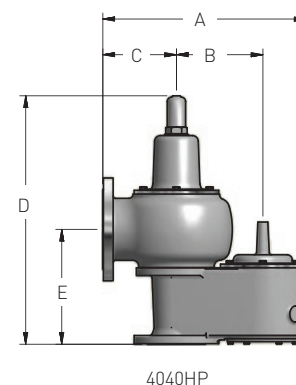

4040HC

Size		A	B	C	D	E
Inches	DN					
2	50	398	160	153	527	231
3	80	494	200	193	604	276
4	100	553	235	200	676	313
6	150	726	320	245	948	414
8	200	941	405	330	1215	513
10	250	1158	500	410	1474	598
12	300	1358	590	480	1710	674

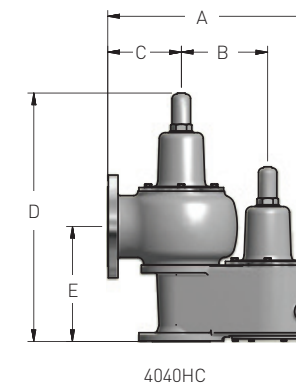

4040HV

Size		A	B	C	D	E
Inches	DN					
2	50	398	160	153	404	231
3	80	494	200	193	478	276
4	100	553	235	200	533	313
6	150	726	320	245	708	414
8	200	941	405	330	888	513
10	250	1158	500	410	1090	598
12	300	1358	590	480	1275	674

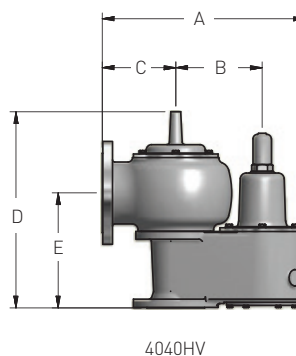

ANDERSON GREENWOOD TYPE 4040 PIPED AWAY PRESSURE AND VACUUM RELIEF VALVES

SIZING

API 2000 - valve sizing (air)

Once the required air venting rates have been determined using data from the following pages or supplied by the customer, a calculation should be conducted to determine the required valve discharge area using the formula below. Once this area has been determined, select the first standard valve flow area above this.

Metric units:

$$A = \frac{R F_o}{12515 \times (P_{10} + A_t) \times K_{d0} \times F_o} \sqrt{\frac{K}{M \times T \times Z (K-1)} \left[\left(\frac{P_2 + A_t}{P_{10} + A_t} \right)^{\frac{2}{K}} - \left(\frac{P_2 + A_t}{P_{10} + A_t} \right)^{\frac{K+1}{K}} \right]}$$

Where:

VR	= Air venting requirements	Nm ³ /h Air
A	= Required flow area of valve	cm ²
Kd	= Coefficient of discharge (see page 9)	
P ₁	= Inlet flowing pressure (Set + over pressure – inlet pressure loss)*	Barg
P ₂	= Outlet pressure (Back pressure)	Barg
K	= Ratio of specific heats	Air = 1.4
T	= Temperature at valve inlet	273 deg K
M	= Molecular weight	Air = 28.97
Z	= Compressibility factor	Air = 1.0
A _t	= Atmospheric pressure	1.013 bar
F	= Over pressure factor (Use 1 for Type 4040 valves)	

* The inlet pressure loss is due to factors such as difficult inlet piping, flame arresters, etc. and must be less than overpressure.

ANDERSON GREENWOOD TYPE 4040 PIPED AWAY PRESSURE AND VACUUM RELIEF VALVES

SIZING

TABLE OF FLOW COEFFICIENTS (Kd) - MODEL 4040H

Size		Flow area (cm ²)	API connection		Conical reducer	
Inches	DN		Pressure	Vacuum	Pressure	Vacuum
2	50	21.239	0.705	0.593	0.835	0.813
3	80	46.568	0.705	0.593	0.806	0.800
4	100	83.322	0.705	0.593	0.820	0.765
6	150	186.264	0.705	0.593	0.761	0.724
8	200	326.851	0.606	0.523	0.706	0.680
10	200	510.702	0.563	0.515	0.626	0.675
12	300	730.747	0.540	0.502	0.632	0.649

MINIMUM SET PRESSURES – WEIGHT LOADED

Size		Aluminum			Stainless steel		
Inches	DN	V mbarg	L mbarg	H mbarg	V mbarg	L mbarg	H mbarg
2	50	1.04	2.42	4.87	2.38	5.91	9.70
3	80	0.84	1.74	4.36	1.84	3.98	8.46
4	100	0.90	1.64	4.48	1.93	3.63	8.90
6	150	0.96	1.60	6.33	1.92	3.90	13.37
8	200	1.10	1.30	13.00	2.50	3.80	20.00
10	250	1.10	1.20	14.00	2.50	3.50	22.00
12	300	1.10	1.20	14.00	2.50	3.20	24.00

NOTE

V = very low pressure pallet
 L = low pressure pallet
 H = high pressure pallet

MINIMUM SET PRESSURES – SPRING LOADED

Size		Aluminum				Stainless steel			
Inches	DN	V mbarg	L mbarg	H mbarg	Spring mbarg	V mbarg	L mbarg	H mbarg	Spring mbarg
2	50	1.04	2.42	4.87	N/A	2.38	5.91	9.70	70
3	80	0.84	1.74	4.36	N/A	1.84	3.98	8.46	70
4	100	0.90	1.64	4.48	N/A	1.93	3.63	8.90	70
6	150	0.96	1.60	6.33	N/A	1.92	3.90	13.37	70
8	200	1.10	1.30	13.00	N/A	2.50	3.80	20.00	70
10	250	1.10	1.20	14.00	N/A	2.50	3.50	22.00	70
12	300	1.10	1.20	14.00	N/A	2.50	3.20	24.00	70

NOTE

V = very low pressure pallet
 L = low pressure pallet
 H = high pressure pallet

ANDERSON GREENWOOD TYPE 4040 PIPED AWAY PRESSURE AND VACUUM RELIEF VALVES

FLOW CAPACITIES

API 2000 connection

API connection testing requires a square-edge flange connection for capacity publishing. This setup mimics a typical tank connection with its inherent pressure drop/capacity.

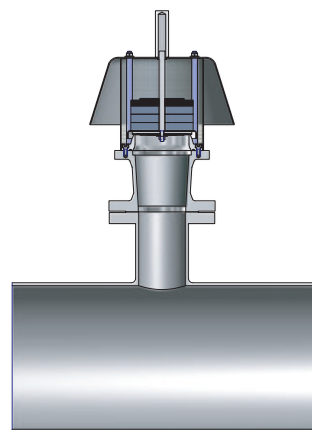

PRESSURE PERFORMANCE

4040H/4040HV
(ISO/API connection)

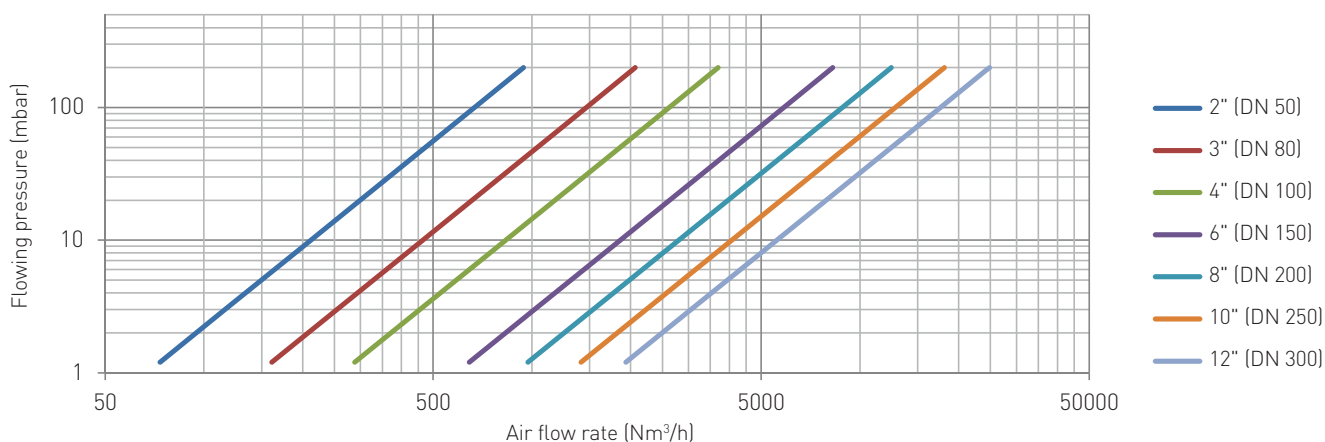

4040HP/4040HC
(ISO/API connection)

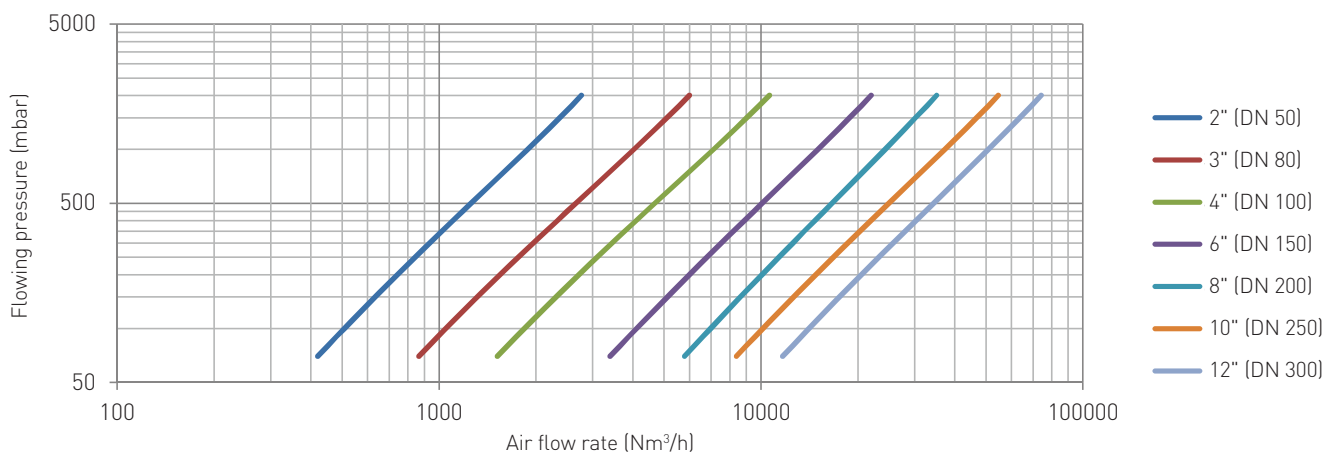

ANDERSON GREENWOOD TYPE 4040 PIPED AWAY PRESSURE AND VACUUM RELIEF VALVES

FLOW CAPACITIES

API 2000 connection

API connection testing requires a square-edge flange connection for capacity publishing. This setup mimics a typical tank connection with its inherent pressure drop/capacity.

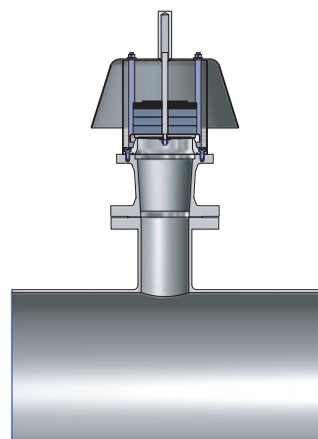

VACUUM PERFORMANCE

4040H/4040HP
(ISO/API connection)

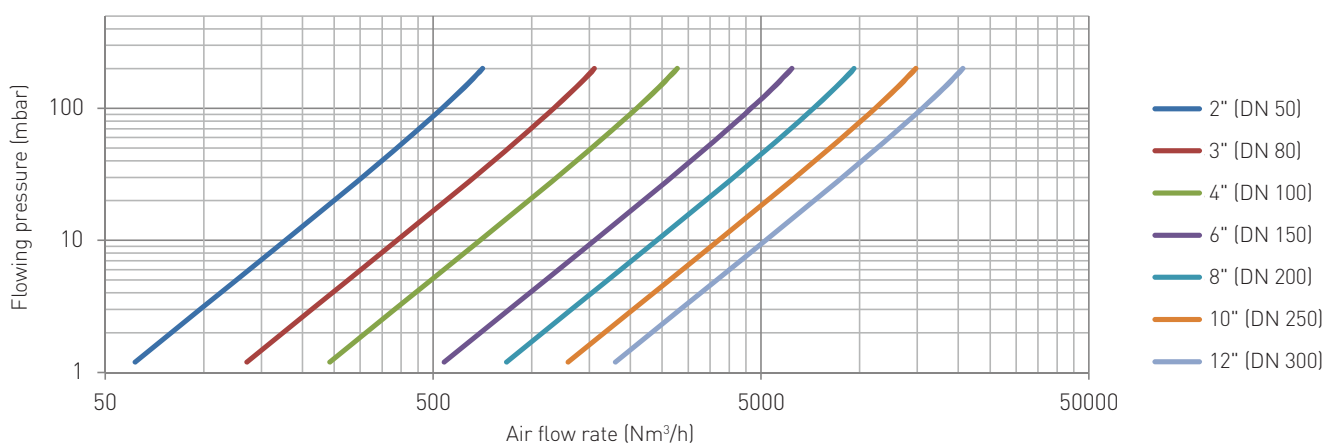

4040HC/4040HV
(ISO/API connection)

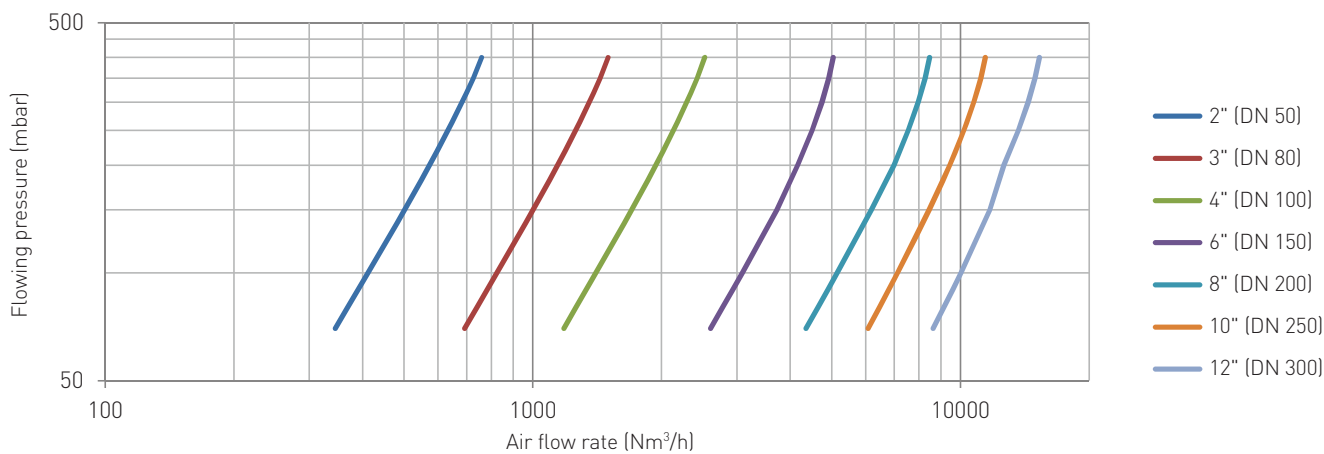

ANDERSON GREENWOOD TYPE 4040 PIPED AWAY PRESSURE AND VACUUM RELIEF VALVES

FLOW CAPACITIES

Conical reducer

A conical reducer reduces the flow losses associated with the tank connection, providing the more accurate representation of pure valve performance. With this capacity, users can calculate their own tank connection losses and apply it to the valve flow.

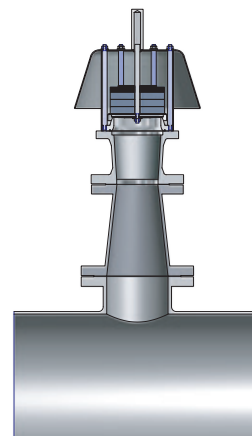

PRESSURE PERFORMANCE

4040H/4040HV
(Conical reducer)

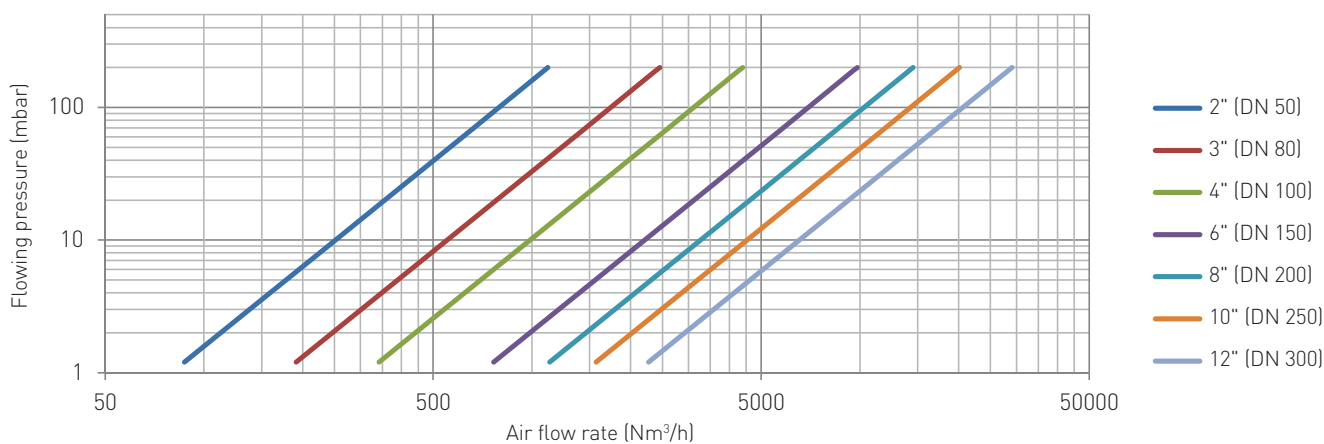

4040HP/4040HC
(Conical reducer)

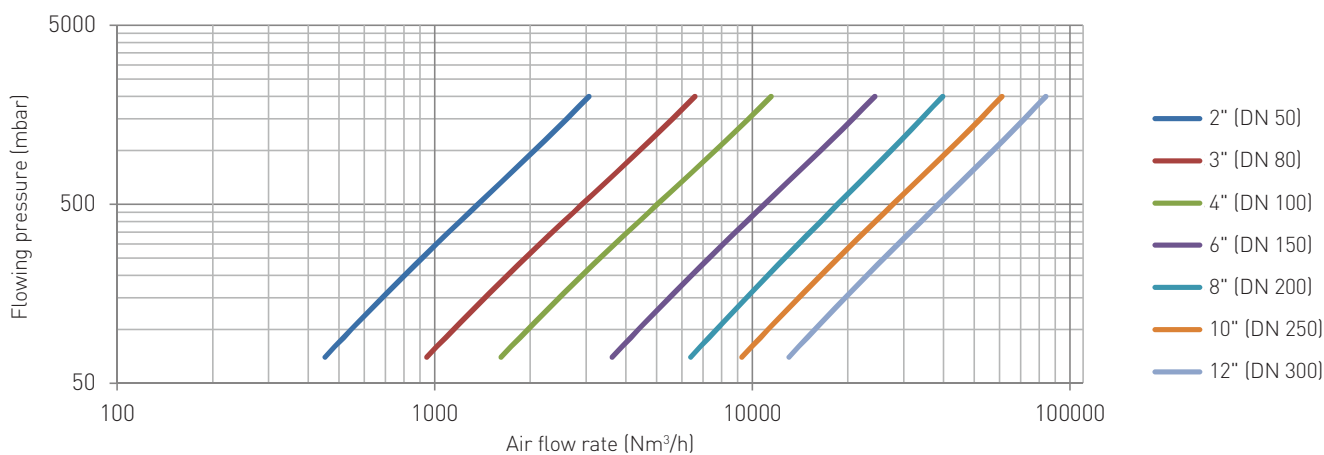

ANDERSON GREENWOOD TYPE 4040 PIPED AWAY PRESSURE AND VACUUM RELIEF VALVES

FLOW CAPACITIES

Conical reducer

A conical reducer reduces the flow losses associated with the tank connection, providing the more accurate representation of pure valve performance. With this capacity, users can calculate their own tank connection losses and apply it to the valve flow.

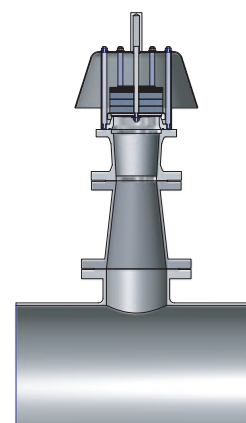

VACUUM PERFORMANCE

4040H/4040HP
(Conical reducer)

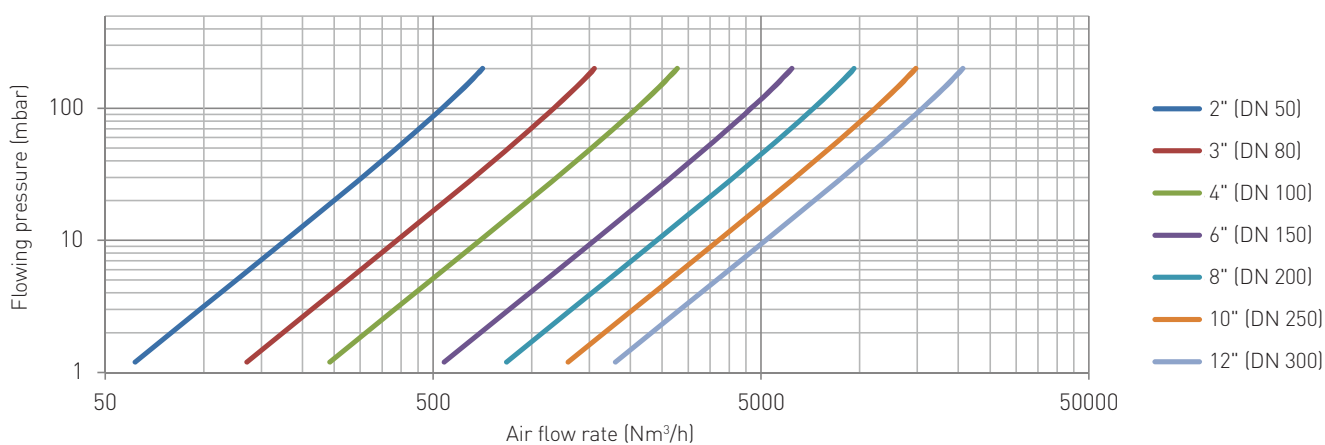

4040HC/4040HV
(Conical reducer)

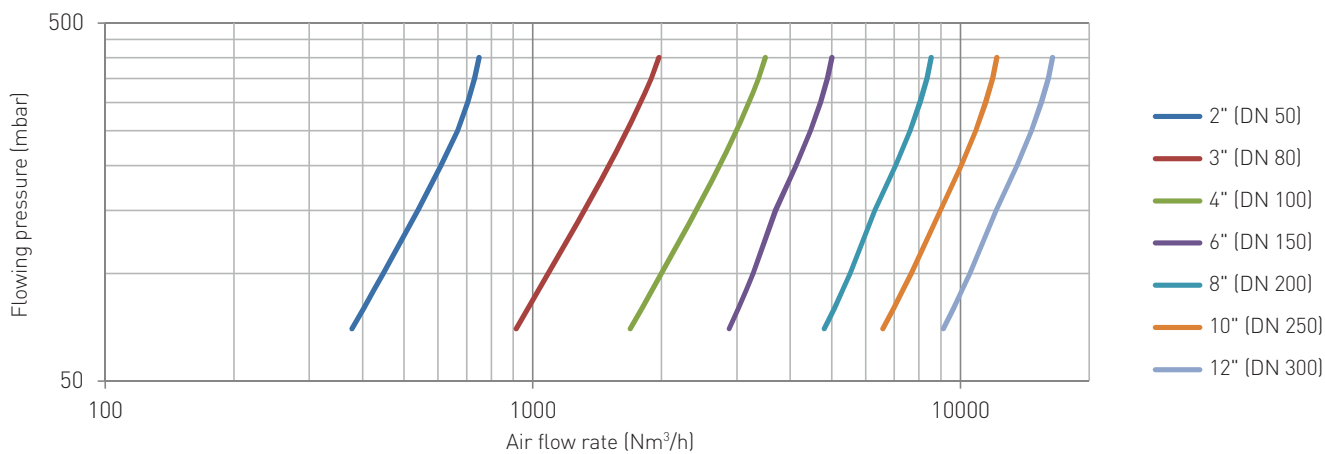

ANDERSON GREENWOOD TYPE 4040 PIPED AWAY PRESSURE AND VACUUM RELIEF VALVES

SELECTION GUIDE

Example:	4040H	04	H	H	1	1	S	T	F	F	B	N
Model												
4040H												
4040HP												
4040HC												
4040HV												
Tank connection												
02 2" (2" x 3")	04 4" (4" x 6")	08 8" (8" x 10")	12 12" (12" x 14")									
03 3" (3" x 4")	06 6" (6" x 8")	10 10" (10" x 12")										
Pressure load												
V Weight loaded – very low pressure pallet												
L Weight loaded – low pressure pallet												
H Weight loaded – high pressure pallet												
O Not applicable												
Vacuum load												
V Weight loaded – very low pressure pallet												
L Weight loaded – low pressure pallet												
H Weight loaded – high pressure pallet												
O Not applicable												
Body material												
1 Aluminum												
3 Carbon steel												
5 316 Stainless steel (CF8M)												
7 316L Stainless steel (CF3M)												
Trim (pallet/seat)												
1 AL pallets/AL seat												
2 316SS pallets/316SS seat												
3 316LSS pallets/316LSS seat												
4 316SS press pallet, coated AL vac pallet, SS seat												
All-weather code												
S Standard, no coating												
W PTFE coated winterization												
Insert												
T Carbon impregnated PTFE (standard for HP pallet)												
B PFA (standard for VLP and LP pallet)												
V FKM												
Flange drilling												
F ANSI 150 for imperial studs												
O DIN PN10 for metric studs												
6 DIN PN16 for metric studs												
Flange face												
F Flat face												
R Raised face (not available for aluminum bodies)												
Soft Goods												
B Nitrile/NBR (standard)												
T PTFE												
V FKM												
Options												
N None (standard)	S Stainless steel weights	B Proximity switch (Press side)										
A Proximity switch (Vac side)	H Purge holes	J Steam jackets										