

PRESSURE REGULATORS

Type B/240



TARTARINI™

EMERSON™

B/240 Regulators

B/240 Series Pressure Regulator

The regulators of the B/240 Series due to their operating specifications are mainly used in those system where sudden capacity variations are required, or else, where the cut-off of the gas distribution is controlled by solenoid valve, such as for the feeding of burners.

This product has been designed to be used with fuel gases of 1st and 2nd family according to EN 437, and with other non aggressive and non fuel gases. For any other gases, other than natural gas, please contact your local sales agent..

The B/240 Series regulators are spring controlled single seated, whit counterbalanced valve disc. They are usually supplied with safety valve and built in filter and can be also provided with shut-off device for minimum pressure, maximum pressure or minimum and maximum downstream pressure.

The regulators of the B/240 Series have been devised keeping in consideration the functionality of maintenance, in fact is possible to replace the seat or the seals without removing the body from the line.

Main features:

- **Counterbalanced valve**
- **Available with or without relief valve**
- **Overpressure and underpressure slam shut valve**
- **Manual reset**

Configurations

Version Without Shut-off Device



B/242



B/242-AP

Version With Shut-off Device

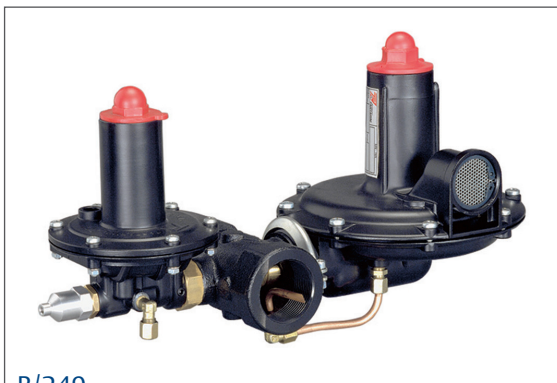

B/249



B/249-AP

Regulator Operation

The movements of the diaphragm (D) are transmitted to the valve disc (O) by the stem (S) and the lever (L).

The downstream pressure through the pulse pipe (I) exerts a force under diaphragm (D) and this force is counteracted by the adjusting spring (M).

The gas pressure on the diaphragm tends to close the valve disc; the antagonist action of the adjustment spring tends to open it. Under normal conditions the balance between these antagonist actions positions the valve disc in such a way as to ensure a constant pressure and therefore the downstream capacity.

Upon any capacity variation tending to cause an increase or decrease of pressure in relation to the pre-set pressure, the moving unit reacts and finds a new balance, so re-establishing the pressure.

Upon request the regulator is also provided with safety valve (VS) incorporated in the diaphragm (D); the adjustment at the pre-set value is performed by means of spring (M1).

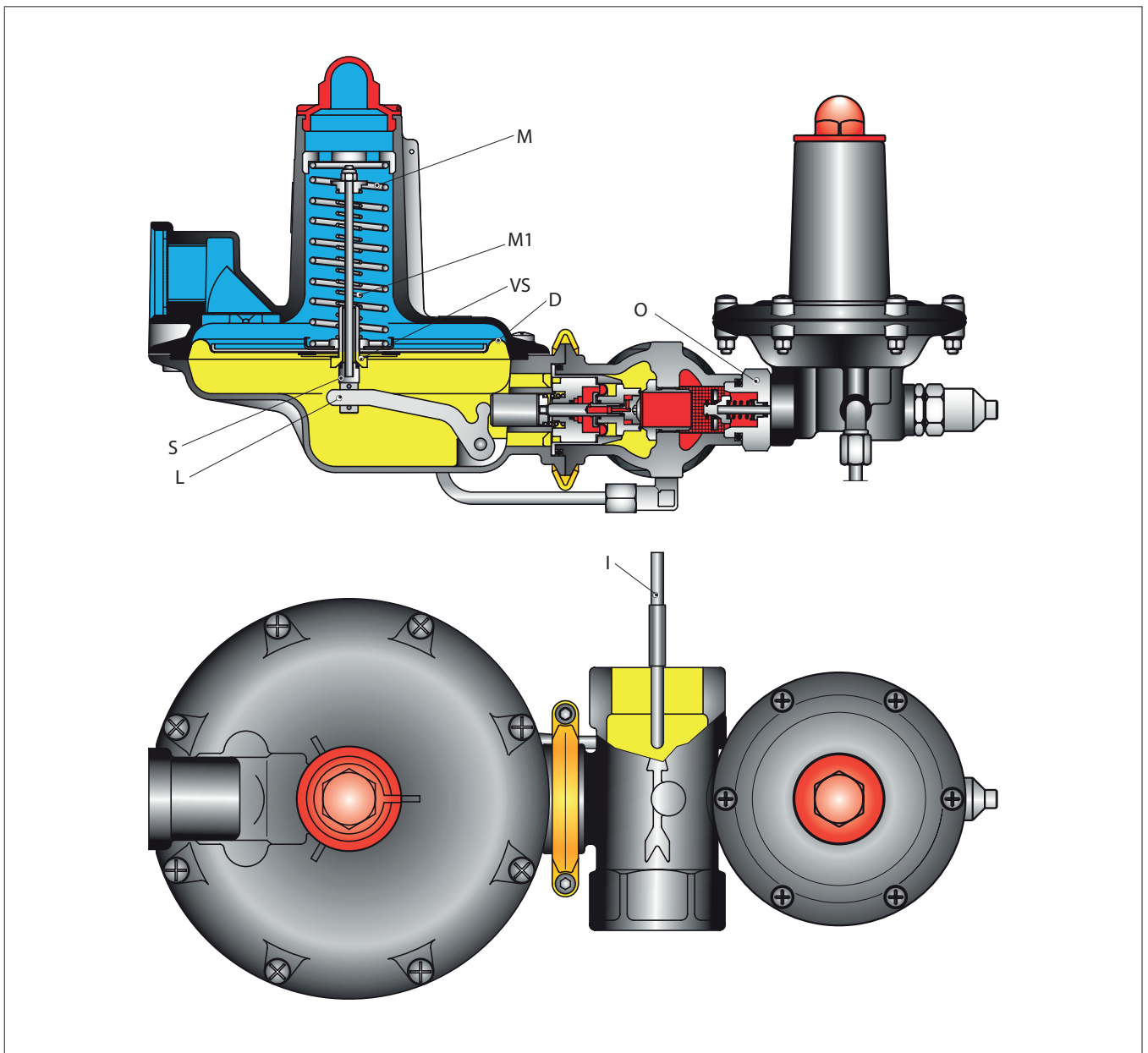

B/240 Regulators

Shut-off Device Operation

The B/240 Series pressure regulators can be fitted with an OS/66 slam-shut valve.

This safety device operates independently of the regulator and, according to customer request, can be made to trigger by any pressure variation, whether above or below set point, or by both.

Outlet pressure acting upon diaphragm (D) is counteracted by maximum pressure spring (M2), thus overcoming the action of the minimum pressure valve (M3).

Under such conditions, the moving part (E) of the valve is held in balance so that lever (L) is aligned with the projecting part of lever (L1).

In addition, the balls (S) are held in their seat by bush (B) and, in turn, these hold the valve disc (O) open.

Any outlet pressure variation over and above preset value breaks the existing balance.

In fact, in case of an increase in outlet pressure, spring (M2) load is overcome by pressure load; in case of a decrease in outlet pressure, spring (M3) load overcomes pressure load.

In both cases, moving part (E) is activated, causing lever (L) to move with it so that lever (L) is no longer aligned with lever (L1).

In this way, lever (L1) releases balls (S), thereby allowing valve disc (O) to close under the action of spring (M4).

The safety device is fitted with an internal by-pass for easy resetting even in case of high inlet pressure. For resetting, proceed as follows: Remove rear cap (C), screw it to stem (H) and pull outwards. Allow a few moments for inlet pressure to flow downstream.

Next, pull cap fully outwards.

Allow a few moments for outlet pressure to stabilize.

Next, release cap and make sure that device remains in the reset position.

If not, repeat the above steps. Once reset, replace cap in its initial position.

The maximum and minimum trip values are independently set by springs (M2) and (M3), respectively.

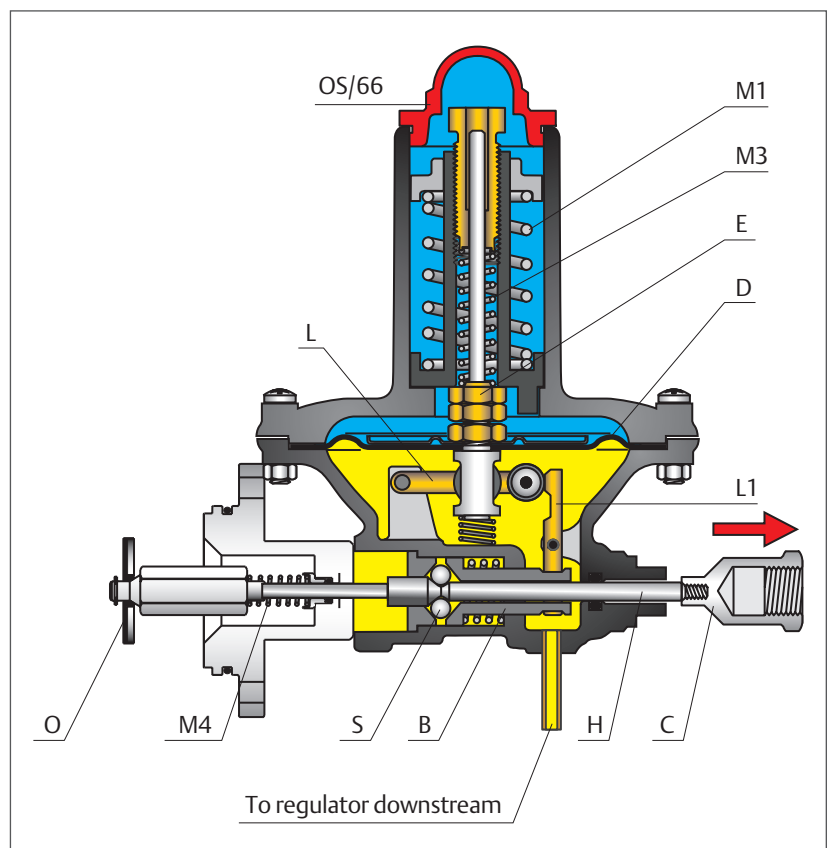

Features

Technical Features

Body allowable pressure	PS	: up to 20 bar
Maximum Operating Inlet Pressure	P_{umax}	: 6 bar
Inlet pressure range	b_{pu}	: 0.1 to 6 bar
Outlet Set Pressure Ranges	W_d	: Standard 15 to 75 mbar AP 75 to 300 mbar AP (QL option) 300 to 500 mbar

Functional Features

Accuracy class	AC	: up to $\pm 5\%$
Lock-up pressure class	SG	: up to +10%
Maximum capacity	Q_{max}	: up to 300 Stm ³ /h

Shut-off device Independent pneumatic control

Accuracy class	AG	: $\pm 5\%$
Response time	t_a	: ≤ 1 second

Orifice

17 mm

Body Sizes and End Connection Styles

Threaded: Inlet and outlet 1 1/2" BSP

Flanged: DN 40 PN 16 UNI/DIN

Temperature

Standard version : Working -10° to 60°C

Low temperature version : Working -20° to 60°C

Versions

Version without relief valve available on request

Materials

Servomotor body	Aluminium
Cover	Aluminium
Body	Ductile iron (steel available on request)
Sleeve	Brass
Seat	Brass
Diaphragm	Fabric Nitrile (NBR)
Gaskets	Nitrile (NBR) rubber

B/240 Regulators

Slam-Shut Device

The following slam-shut devices are used with B/240 Series regulators with built-in shut-off device:

- OS/66 Spring loaded

Technical Features

Model	Servomotor Body Resistance (bar)	Overpressure Set Range W_{do} (bar)		Underpressure Set Range W_{du} (bar)	
		Min.	Max.	Min.	Max.
OS/66	6	0.022	0.6	0.007	0.450
OS/66-AP		0.2	5	0.1	2.5



Materials

Body Aluminium
 Cover Steel
 Diaphragm NBR Rubber

Flow Table Stm^3/h

Following flow tables (referred to Natural Gas) are advised for an optimal use of the B/240 Series regulators.

For other gases with different densities, the flow rate must be multiplied by the correction factor:

$$F = \sqrt{\frac{0.6}{d}}$$

Gas	Relative Density d	Factor F
Air	1	0.78
Butane	2.01	0.55
Propane	1.53	0.63
Nitrogen	0.97	0.79

Outlet Pressure mbar	Inlet Pressure bar																
	0.03	0.05	0.075	0.1	0.15	0.2	0.3	0.4	0.5	0.75	1	1.5	2	3	4	5/6	
Standard	15	12	15	20	30	40	50	65	80	100	120	120	170	200	250	250	250
	20	-	15	20	30	40	50	65	80	100	120	120	170	200	250	250	250
	30	-	12	20	30	40	50	65	80	100	120	120	170	200	250	250	250
	40	-	-	15	25	40	50	65	80	100	120	120	170	200	250	250	250
	50	-	-	15	20	40	50	65	80	100	120	120	170	200	250	250	250
	75	-	-	-	15	30	45	60	80	100	120	120	170	200	250	250	250
AP	100	-	-	-	-	20	40	50	80	100	120	120	170	200	250	280	300
	150	-	-	-	-	-	30	40	70	100	120	120	170	200	250	280	300
	200	-	-	-	-	-	-	30	60	100	120	120	170	200	250	280	300
	300	-	-	-	-	-	-	-	50	80	110	110	170	200	250	280	300
	300	-	-	-	-	-	-	-	30	40	60	80	130	170	200	230	250
	350	-	-	-	-	-	-	-	-	40	60	80	130	170	200	230	250
	400	-	-	-	-	-	-	-	-	35	60	80	130	170	200	230	250
	450	-	-	-	-	-	-	-	-	-	60	80	130	170	200	230	250
500	-	-	-	-	-	-	-	-	-	50	75	120	160	190	220	240	

QL Option

B/240 Regulators

Dimensions (mm) and Weights (kg)

B/249 • B/249-AP

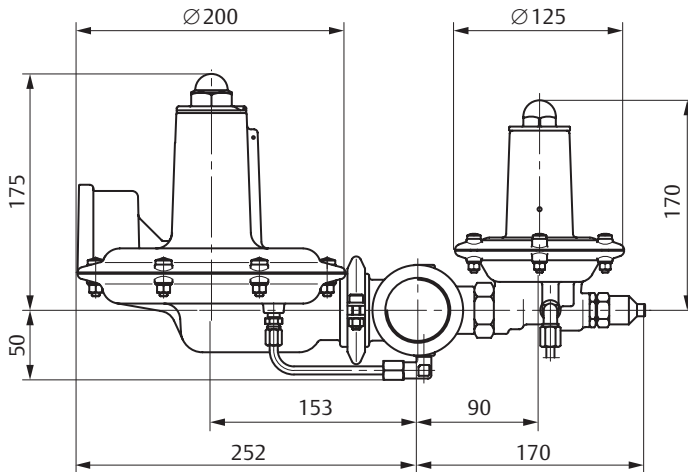

B/242 • B/242-AP

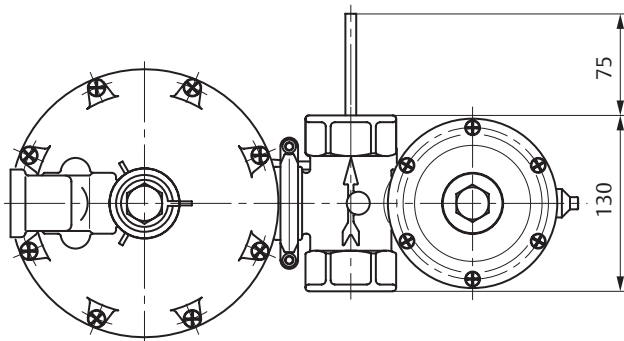
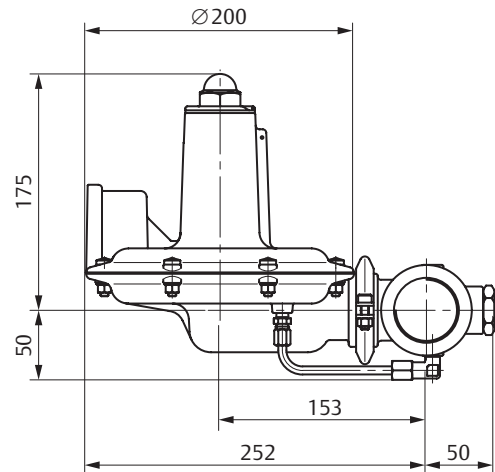

FS Version

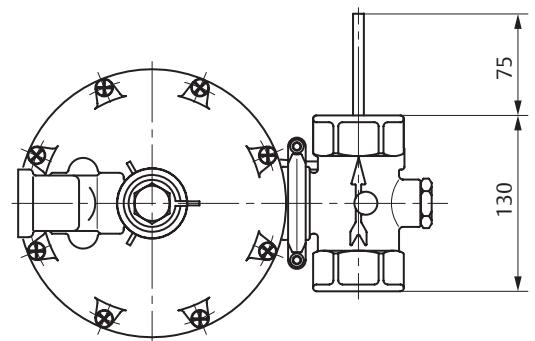

FS Version

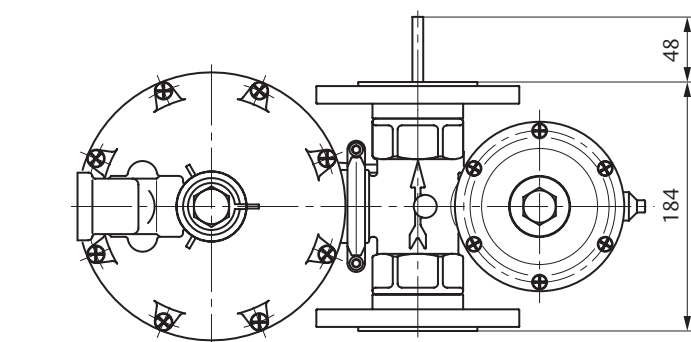

FS Version

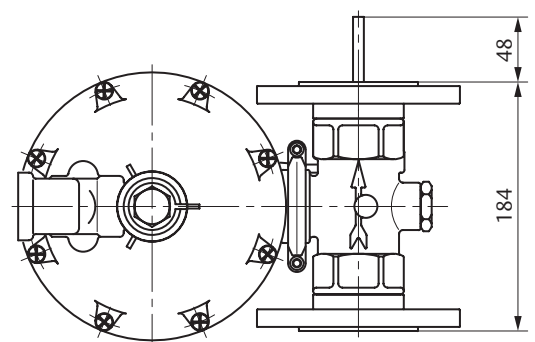

FS Version

Note: The regulator can be installed with vertical or horizontal orientation of the actuator.

Weights

B/242 • B/242-AP: 3.5 kg

B/242-FS • B/242-AP-FS: 7.5 kg

B/249 • B/249-AP: 4.5 kg

B/249-FS • B/249-AP-FS: 8.5 kg

✉ Webadmin.Regulators@emerson.com

🔍 Tartarini-NaturalGas.com

📘 Facebook.com/EmersonAutomationSolutions

🌐 LinkedIn.com/company/emerson-automation-solutions

🐦 Twitter.com/emr_automation

Emerson Automation Solutions

Americas

McKinney, Texas 75070 USA
T +1 800 558 5853
+1 972 548 3574

Europe

Bologna 40013, Italy
T +39 051 419 0611

Asia Pacific

Singapore 128461, Singapore
T +65 6770 8337

Middle East and Africa

Dubai, United Arab Emirates
T +971 4 811 8100

O.M.T. Officina Meccanica Tartarini S.R.L., Via P. Fabbri 1, I-40013 Castel Maggiore (Bologna), Italy
R.E.A 184221 BO Cod. Fisc. 00623720372 Part. IVA 00519501209 N° IVA CEE IT 00519501209,
Cap. Soc. 1.548 000 Euro i.v. R.I. 00623720372 - M BO 020330

Francel SAS, 3 Avenue Victor Hugo, CS 80125, Chartres 28008, France
SIRET 552 068 637 00057 APE 2651B, N° TVA : FR84552068637, RCS Chartres B 552 068 637,
SAS capital 534 400 Euro

D103746X012 © 2017 Emerson Process Management Regulator Technologies, Inc. All rights reserved. 12/18.

The Emerson logo is a trademark and service mark of Emerson Electric Co. All other marks are the property of their prospective owners. Tartarini™ is a mark of O.M.T. Officina Meccanica Tartarini s.r.l., a business of Emerson Automation Solutions.

The contents of this publication are presented for information purposes only, and while effort has been made to ensure their accuracy, they are not to be construed as warranties or guarantees, express or implied, regarding the products or services described herein or their use or applicability. All sales are governed by our terms and conditions, which are available on request. We reserve the right to modify or improve the designs or specifications of our products at any time without notice.

Emerson Process Management Regulator Technologies, Inc does not assume responsibility for the selection, use or maintenance of any product. Responsibility for proper selection, use and maintenance of any Emerson Process Management Regulator Technologies, Inc. product remains solely with the purchaser.

