

September 2021

Type BM5A Slam-Shut Valve

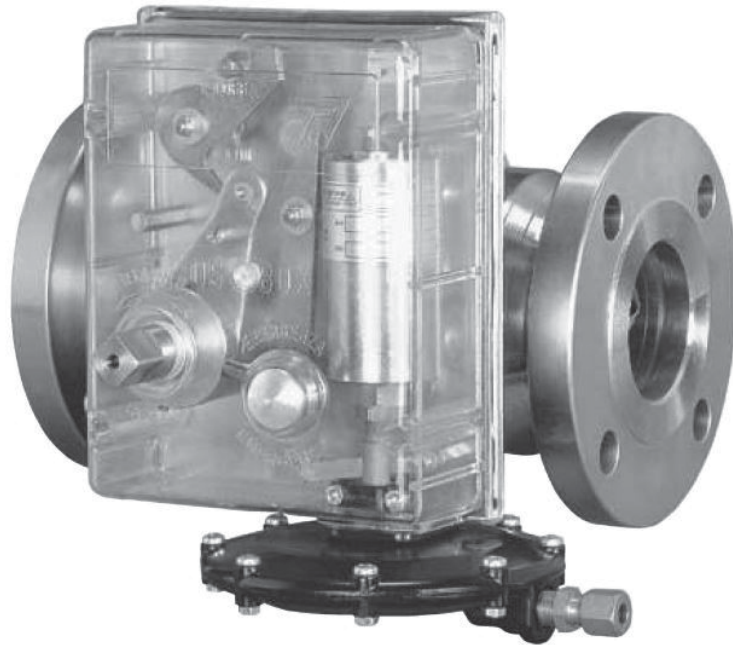

Figure 1. Type BM5A Slam-Shut Valve

Features

- **Axial Flow design with fully balanced sliding shutter valve**
- **No need for external by-pass valve to open the main valve even in pressurized condition**
- **Flanged connections**
- **Protected seal pad**
- **Possible to fit in all positions**
- **Pressure control in one or more points of the installation**
- **Push-button manual emergency release**
- **Manual reset through rotation of the reset shaft only**

Introduction

Type BM5A slam-shut valve is an automatic shut-off device suitable for installation as safety device in regulating, distribution and transmission stations of suitably filtered natural gas.

Type BM5A is designed to be used with fuel gases of 1st and 2nd family according to EN 437, and with other non aggressive and non fuel gases. For any other gases, other than natural gas, please contact your local sales office.

The slam-shut valve quickly shuts off the gas flow when the pressure in control point(s) reaches a fixed set value.

The slam-shut valve features a shutter valve sliding axially, therefore, no by-pass is needed for its opening even in the presence of pressurized gas.

The main valve can be opened manually only by turning the reset shaft in the marked direction.

Type BM5A

Specifications

The Specifications section gives some general specifications for the Type BM5A slam-shut valve. The nameplates give detailed information for a particular slam-shut valve as built in the factory.

Available Body Sizes

DN 25, 50, 80, 100, and 150 /
NPS 1, 2, 3, 4, and 6

Available End Connection Styles

CL300 RF and CL600 RF

Maximum Allowable Pressure⁽¹⁾

CL300 RF: 50 bar / 725 psig
CL600 RF: 103 bar / 1500 psig

Maximum Operating Inlet Pressure (PS_{max})⁽¹⁾⁽²⁾

CL300 RF: 50 bar / 725 psig
CL600 RF: 100 bar / 1450 psig

Inlet Pressure Range (b_{pu})⁽¹⁾⁽²⁾

CL300 RF: 0 to 50 bar / 0 to 725 psig
CL600 RF: 0 to 100 bar / 0 to 1450 psig

Overpressure Set Range (W_{do})

CL300 RF: 0.03 to 50.0 bar / 0.44 to 725 psig
CL600 RF: 0.03 to 80.0 bar / 0.44 to 1160 psig

Underpressure Set Range (W_{du})

CL300 RF: 0.01 to 50.0 bar / 0.15 to 725 psig
CL600 RF: 0.01 to 80.0 bar / 0.15 to 1160 psig

Accuracy Class (AG)

Up to $\pm 1\%$

Response Time (t_a)

≤ 1 s

Minimum/Maximum Allowable Temperature (TS)⁽¹⁾⁽²⁾

Class 1: -10 to 60°C / 14 to 140°F
Class 2: -20 to 60°C / -4 to 140°F

Working Temperature Capabilities⁽¹⁾⁽²⁾

**Standard Version, Nitrile (NBR) or
Fluorocarbon (FKM):** -10 to 60°C / 14 to 140°F
Low Temperature Version, Nitrile (NBR):
-20 to 60°C / -4 to 140°F

Available Slam-Shut Controllers

See Table 1

Construction Materials

Slam-Shut Valve

Body: Steel
Shutter: Steel
O-ring: Nitrile (NBR) or Fluorocarbon (FKM)
Pad: Nitrile (NBR) or Fluorocarbon (FKM)
Pad holder: Steel

OS/80X Series Slam-Shut Controller

Body: Aluminum (Types OS/80X-BP and OS/80X-BPA-D) or Steel (Types OS/80X-MPA-D and OS/80X-APA-D)
Diaphragm: Fabric-finished Nitrile (NBR)
O-ring: Nitrile (NBR)

Types OS/84X and OS/88X Slam-Shut Controller

Body: Brass
Lip Seal: Polytetrafluoroethylene (PTFE)
O-ring: Nitrile (NBR)

PRX/181/182 and PRX-AP/181/182 Series Pilots

Body: Steel
Diaphragm: Fabric-finished Nitrile (NBR)
O-ring: Nitrile (NBR)

Slam-Shut Controller and Pilot Connection

1/4 NPT

Approximate Weights

See Table 5

Accessories

- Proximity Switch or Micro Switch for Remote Monitoring
- Solenoid Valve for Remote-controlled Closure
- IT/3V Three-Way Valve for Setting Control

1. The pressure/temperature limits in this Instruction Manual and any applicable standard or code limitation should not be exceeded.
2. Published values are in accordance with EN14382 specifications at average ambient temperature.

Table 1. OS/80X and OS/80X-PN Series Slam-Shut Controller Pressure Rating

TYPE	BODY RATING		OVERPRESSURE SET RANGE, W_{Do}				UNDERPRESSURE SET RANGE, W_{Du}				BODY MATERIAL
			Minimum		Maximum		Minimum		Maximum		
	bar	psig	bar	psig	bar	psig	bar	psig	bar	psig	
OS/80X-BP	5.0	73	0.03	0.44	2.0	29	0.01	0.15	0.60	8.7	Aluminum
OS/80X-BPA-D	20.0	290									
OS/80X-MPA-D	100	1450	0.50	7.25	5.0	73	0.25	3.63	4.0	58	Steel
OS/80X-APA-D			2.0	29	10.0	145	0.30	4.35	7.0	102	
OS/84X			5.0	73	41.0	595	4.0	58	16.0	232	Brass
OS/88X			18.0	261	80.0	1160	8.0	116	70.0	1015	
OS/80X-PN ⁽¹⁾			0.50	7.25	40.0	580	0.50	7.25	40.0	580	Steel
OS/84X-PN ⁽¹⁾			30.0	435	80.0	1160	30.0	435	80.0	1160	Brass

1. **Type OS/80X-PN:** Made of a Type OS/80X-APA-D, set at about 0.4 bar and Type PRX/182-PN pilot for overpressure and Type PRX/181-PN for underpressure as necessary to control the system pressure. **Type OS/84X-P:** Made of a Type OS/84X, set at about 20 bar and Type PRX-AP/182-PN pilot for overpressure and Type PRX-AP/181-PN for underpressure as necessary to control the system pressure.

Product Description

Main Valve

Type BM5A slam-shut valve uses the pipeline gas pressure for its operation and therefore, it does not require any external energy to operate.

It has a sleeve-type valve, therefore does not need any external by-pass to facilitate the opening of the valve.

The valve can only be opened manually by turning the eccentric shaft counterclockwise if the upstream and downstream pressures are equal.

Controller

The following controllers are used with the Type BM5A slam-shut valves:

- OS/80X Series: Spring loaded pneumatic device
- OS/80X-PN Series: Pneumatic device controlled by PRX Series pilots

OS/80X Series

The OS/80X Series controller is supplied in different models according to set ranges required. The Type BM5A DN 150 / NPS 6 is equipped with a reinforced version Type OS/80X-R.

OSX/80-PN Series

The OS/80X-PN Series controller is supplied in two types:

1. Type OS/80X-PN: Pressure range is 0.5 to 40 bar / 7.25 to 580 psig. This controller is made up of Type OS/80X-APA-D controller which is set at about 0.4 bar / 5.80 psig and Type PRX/182-PN pilot of suitable spring range for overpressure and Type PRX/181-PN of suitable spring range for underpressure.
2. Type OS/84X-PN: Pressure range is 30 to 80 bar / 435 to 1160 psig. This controller is made of Type OS/84X-R set at about 20 bar / 290 psig and Type PRX-AP/182-PN pilot of suitable spring range for overpressure and Type PRX-AP/181-PN of suitable spring range for underpressure.

Type BM5A



Figure 2. OS/80X-BP Series Slam-Shut Controller

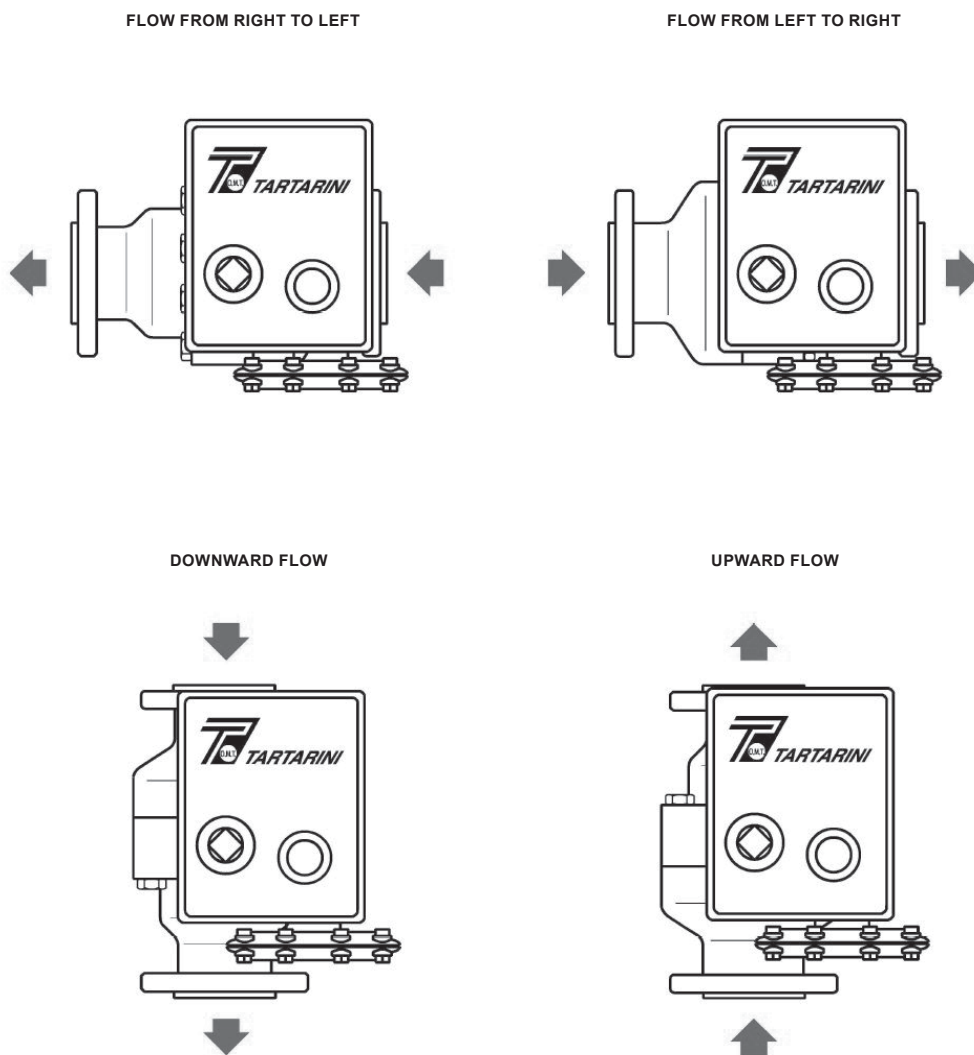

Figure 3. Type BM5A Slam-Shut Valve Flow Orientation



Figure 4. Proximity Switch

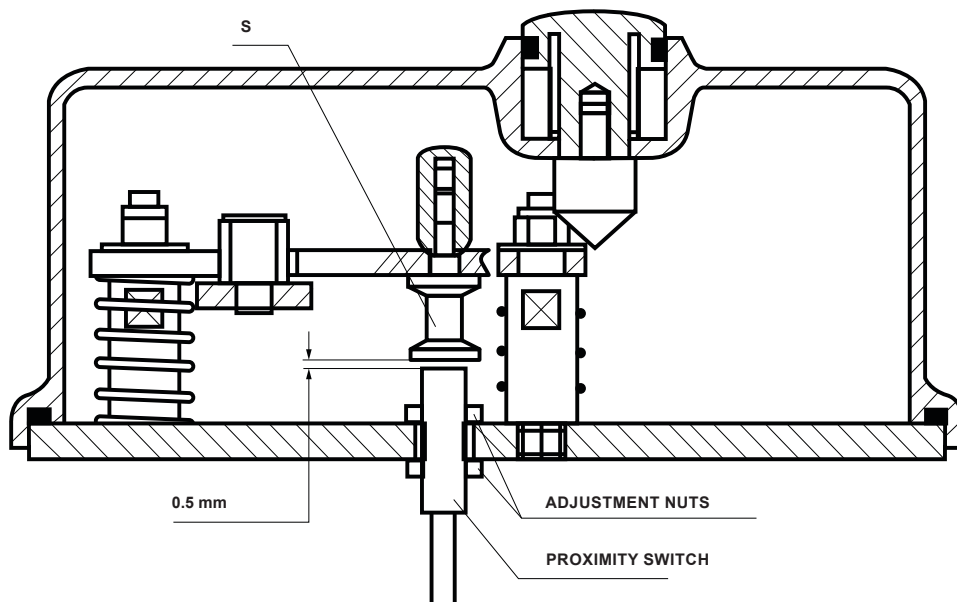

Figure 5. Proximity Switch Installation

Type BM5A

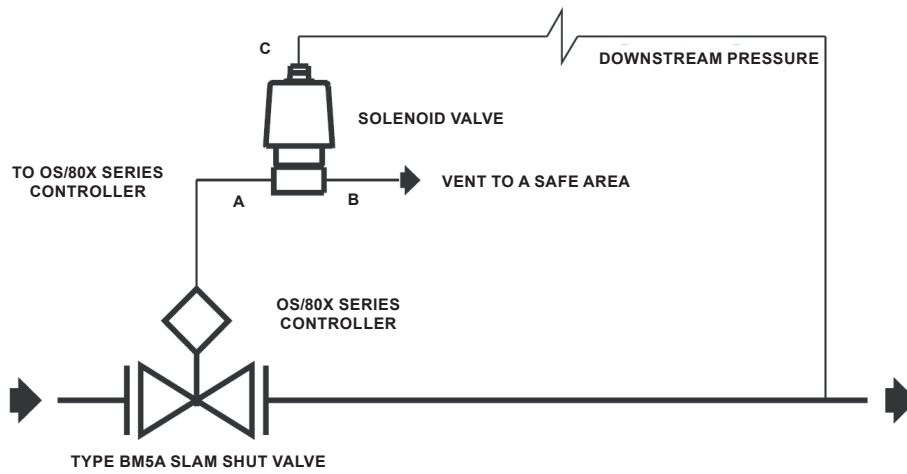

Figure 6. Solenoid Valve Installation

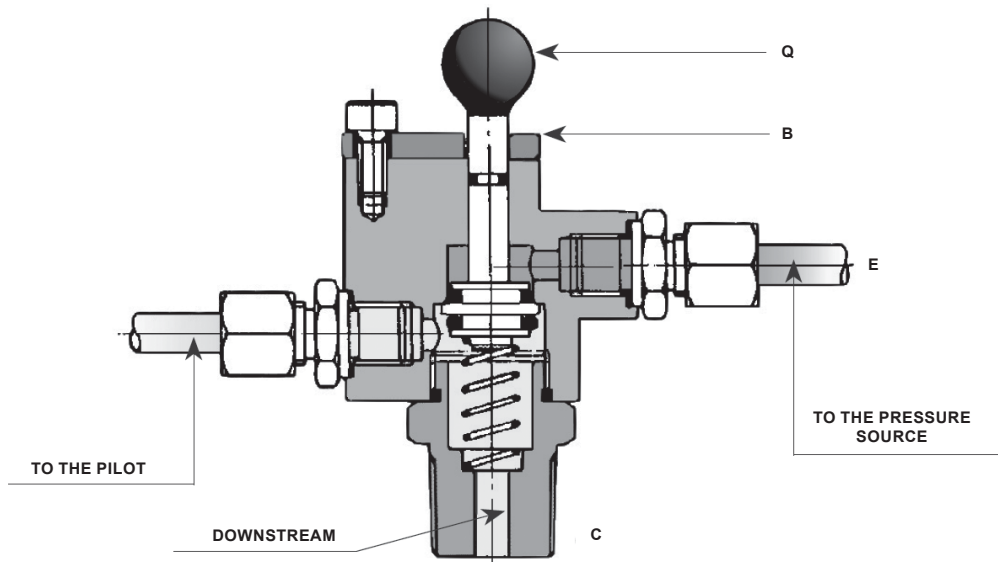

Figure 7. IT/3V Three-way Valve Installation

Accessories

Proximity Switch

In order to send the shut-off opening/closing signal to a remote location, a proximity switch suitable for installation in hazardous area is used.

The use of this switch foresees the application of an intrinsic safety separation barrier which should be installed in safe area.

The distance between the proximity switch and the barrier should be calculated according to the type of gas and installation electrical specifications.

The proximity switch should be positioned at about 0.5 mm / 0.02 in. from the stem (S).

The adjustment is made by means of adjusting nuts.

On request it is possible to supply the controller in the version with two proximity switches in order to indicate extreme positions of valve opening/closing.

Solenoid Valve for Remote Controlled Closure

The Types OS/80X and the OS/80X-PN equipped with a shut-off device for minimum pressure, can be equipped with a three-way solenoid valve with explosion-proof construction to permit remote-controlled closure. See Figure 6.

IT/3V Three-Way Valve for Setting Control (Pu max 50 bar / 725 psig)

It allows the Type OS/80X operation and setting control, without having to change the regulator setting.

The valve is installed on the Type OS/80X control line and it must be connected to a suitable pressure source that is capable of reaching the settings of the Type OS/80X.

The IT/3V three-way valve is of the spring-return type and it is equipped with a safety lock plate (B) on the control knob (Q).

When the plate (B) is pivoted, pressure on the knob (Q) makes it possible to put the sensitive member into communication with a pressure source, thus making it possible to perform operation and setting tests. See Figure 7.

Upon completion of the procedures, releasing the knob will reset normal running conditions. The safety lock plate on the knob prevents accidental maneuvers.

Principle of Operation

Type BM5A slam-shut valve is essentially made of a main axial flow valve and a controller that keeps the main valve in open position in normal conditions. The valve body features a shutter valve sliding axially and as a consequence no by-pass is needed for its opening even in the presence of pressurized gas.

This main valve can be opened manually only by turning the reset shaft in the marked direction. The seal pad is not directly hit by the gas flow since it is not facing the flow stream and is protected by the pad holder and as a consequence is not affected by any possible dirt present in the gas. When the controlled pressure is within set values of the controller, this remains set and prevents the rotation of the eccentric shaft that determines the valve open position. When controlled pressure varies beyond set values, the controller releases the eccentric shaft and the valve is brought to its closing position by the spring thrust.

The controller is provided with a manual release push-button to quickly close the slam-shut valve in case of emergency or during maintenance/checking operations.

Should the slam shut valve be used with pilot-operated pressure regulators, the supply to pilots should be taken downstream of the slam-shut valve. For this purpose, BM5A valves feature a tapped hole to be used for supply to pilots; the hole is normally kept closed by a dowel. The supply to pilots can also be made through conventional tapping in pipeline made at upstream of the pressure regulators.

Installation

BM5A Series slam-shut valves can be installed on the piping with both horizontal axis and vertical axis and with any gas flow orientation.

The controller can be turned by 90° steps to allow its orientation to be in vertical position with the adjusting screws turned upwards in order to obtain an optimal operation and an easier setting control.

To reduce the overall dimensions in a particular installation, the Type OS/80X-S version with clockwise resetting is available on request.

Type BM5A

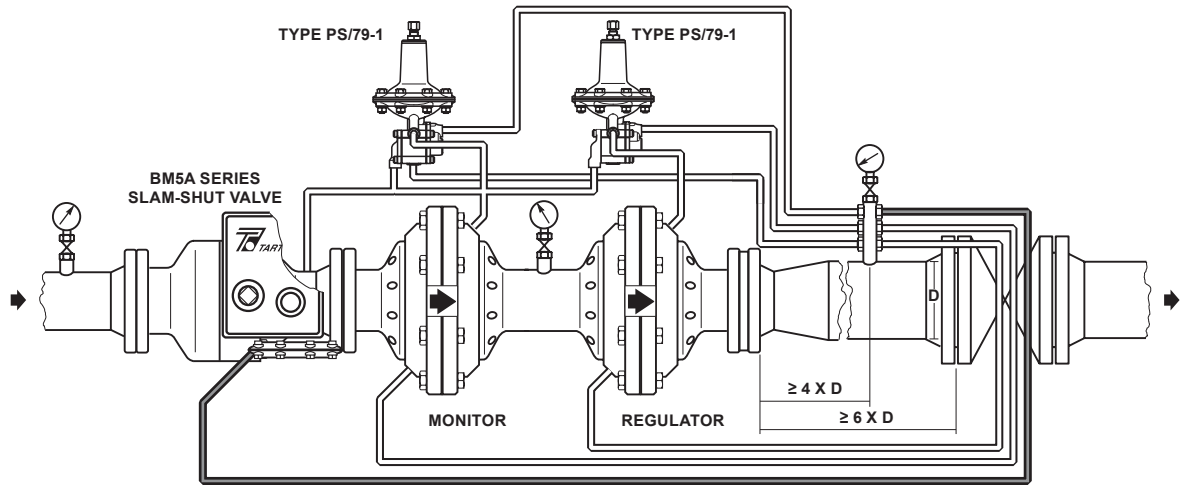

SLAM-SHUT VALVE WITH TYPE OS/80X CONTROLLER – INSTALLATION IN A LOW PRESSURE REGULATING LINE

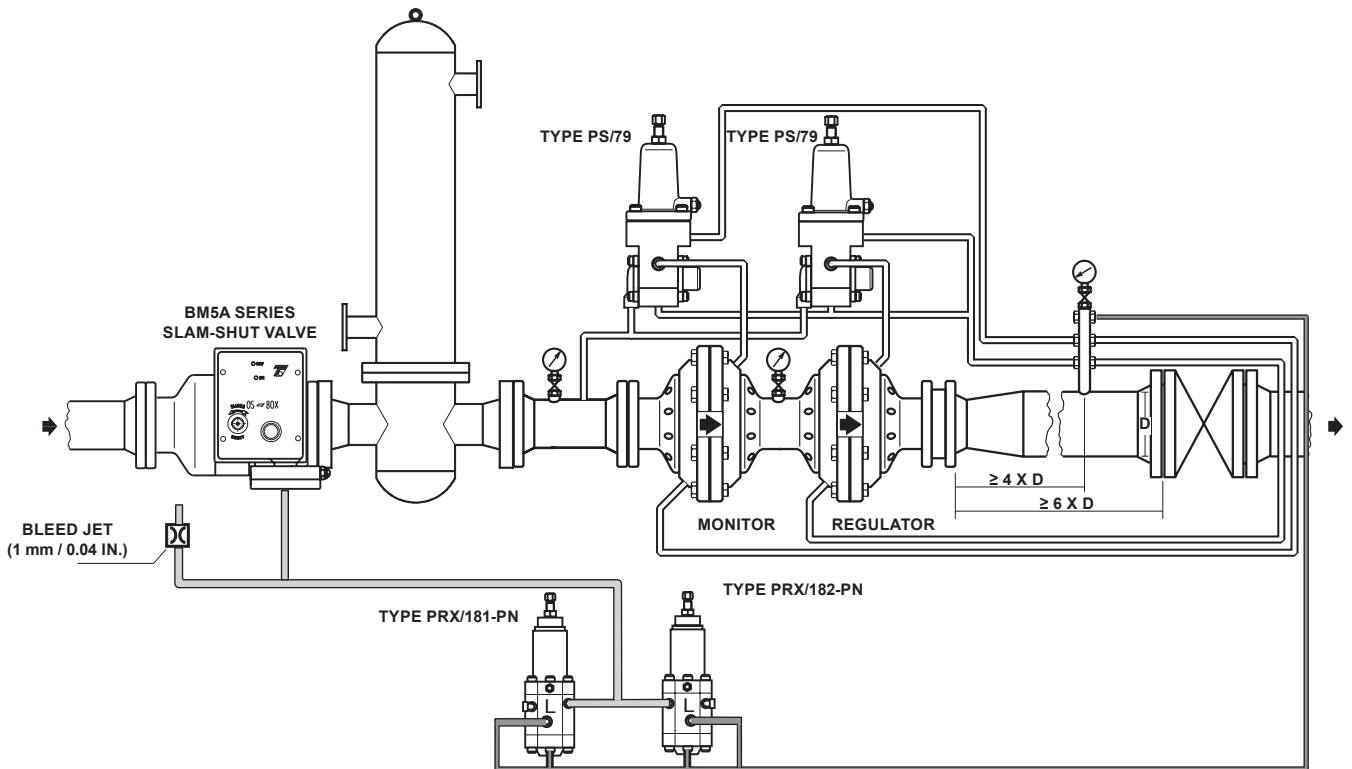

SLAM-SHUT VALVE WITH TYPE OS/80X-PN CONTROLLER – OVERPRESSURE AND UNDERPRESSURE CONTROL DOWNSTREAM OF REGULATORS

Figure 8. Type BM5A Installation Schematics

Table 2. Flow Coefficients

COEFFICIENT	DN 25 / NPS 1	DN 50 / NPS 2	DN 80 / NPS 3	DN 100 / NPS 4	DN 150 / NPS 6
C _g	525	2250	5400	8700	18600
C ₁	29	26	30	26	28

Table 3. Gas Conversion

GAS	RELATIVE DENSITY (d)	FACTOR (F)
Air	1	0.78
City gas	0.44	1.17
Butane	2.01	0.55
Propane	1.53	0.63
Nitrogen	0.97	0.79
Carbon dioxide	1.52	0.63
Hydrogen	0.07	2.93

Capacity Information

To find approximate flow capacity and valve diameter, perform the following procedures:

Calculation Procedures

The following formulas refer to normal operating conditions in a sub-critical state with: $P_2 > \frac{P_1}{2}$

Symbols

- Q = Natural gas flow rate in (Stm³/h)
- P₁ = Absolute inlet pressure in bar
- P₂ = Absolute outlet pressure in bar
- C_g = Flow coefficient
- C₁ = Body shape factor
- d = Relative density of the gas

Flow Rate Q

$$Q = 0.525 \times C_g P_1 \sin \left(\frac{3417}{C_1} \sqrt{\frac{P_1 - P_2}{P_1}} \right)^\circ$$

$$Q = 0.525 \times C_g P_1$$

For other gases with different densities, the flow rate calculated with the above formulas must be multiplied with the correction factor:

$$F = \sqrt{\frac{0.6}{d}}$$

Power Loss ΔP

$$\Delta P = \frac{P_1 - \sqrt{P_1^2 - 4 \left(\frac{Q}{C_g \times 1.05} \right)^2}}{2}$$

DN Sizes

Calculate the required C_g with the following formula:

$$C_g = \frac{Q}{0.525 \times P_1 \sin \left(\frac{3417}{C_1} \sqrt{\frac{P_1 - P_2}{P_1}} \right)^\circ}$$

The above formulas apply to natural gas flow rate only. If the flow rate value (Q) refers to other gasses, divide it by the correction factor F. See Table 3.

Choose the slam-shut valve with the C_g higher than the calculated value. After having determined the slam-shut valve diameter, it is suggested to check that the velocity on the seal seat is not higher than 80 m/s by using the following formula:

$$V = 345.92 \times \frac{Q}{DN^2} \times \frac{1 - 0.002 \times P_U}{1 + P_U}$$

V = Velocity (m/s)

345.92 = Numerical constant

Q = Flow rate under standard conditions (Stm³/h)

DN = Valve nominal diameter (mm)

P_U = Inlet pressure in relative value (bar)

In case of velocities higher than indicated limits, increase the valve diameter.

Note: The sine argument is expressed in sexagesimal degree

Type BM5A

Dimensions and Weights

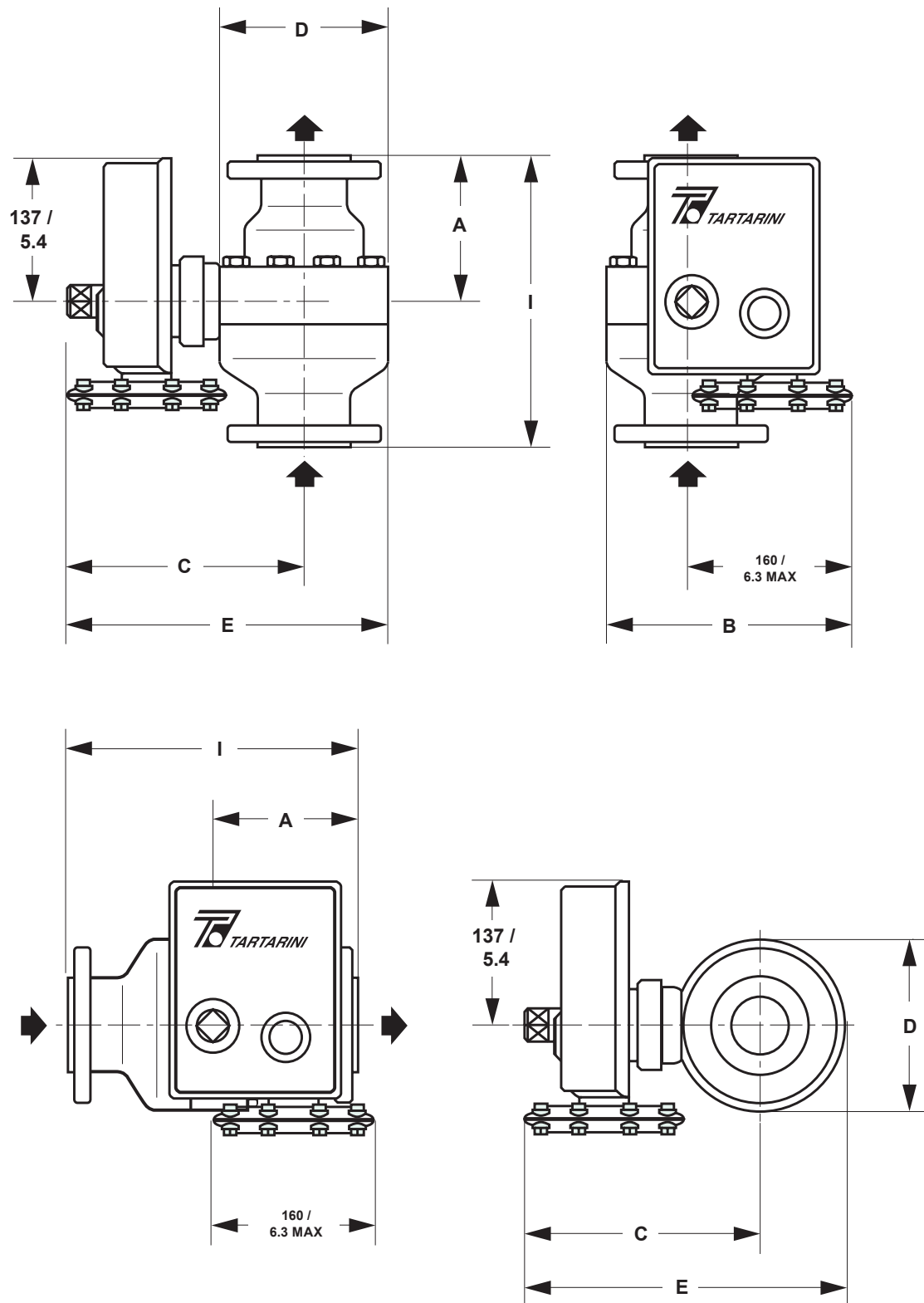

mm / IN.

Figure 9. Type BM5A Dimensions

Table 4. Type BM5A Dimensions

TYPE	DN 25 / NPS 1		DN 50 / NPS 2		DN 80 / NPS 3		DN 100 / NPS 4		DN 150 / NPS 6		
	mm	In.	mm	In.	mm	In.	mm	In.	mm	In.	
A	100	3.9	145	5.7	165	6.5	195	7.7	250	9.8	
B	220	8.7	245	9.6	275	10.8	295	11.6	365	14.4	
C ⁽¹⁾	200	7.9	215	8.5	245	9.6	270	10.6	380	15.0	
D	125	4.9	165	6.5	230	9.1	275	10.8	410	16.1	
E	260	10.2	300	11.8	360	14.2	410	16.1	585	23.1	
CL300 RF	I	197	7.8	266.5	10.5	317.5	12.5	368.5	14.5	473	18.6
CL600 RF		210	8.3	286	11.3	336.5	13.2	394	15.5	508	20

N.B. The C dimensions are indicative and based on models with largest dimensions.

Table 5. Type BM5A Weights

VALVE SIZE AND RATING	DN 25 / NPS 1		DN 50 / NPS 2		DN 80 / NPS 3		DN 100 / NPS 4		DN 150 / NPS 6	
	kg	lbs	kg	lbs	kg	lbs	kg	lbs	kg	lbs
CL300 RF / CL600 RF	17	37.5	30	66	62	137	105	231	280	617

Ordering Information

When ordering, complete the ordering guide on this page. Refer to the Specifications section on page 2. Review the description to the right of each specification and the information in each referenced table or figure. Specify your choice whenever a selection is offered.

Ordering Guide

Body Size

- DN 25 / NPS 1***
- DN 50 / NPS 2***
- DN 80 / NPS 3***
- DN 100 / NPS 4***
- DN 150 / NPS 6***

End Connection

- CL300 RF Flanged***
- CL600 RF Flanged***

Controller Type (Select One)

- Type OS/80X-BP***
- Type OS/80X-BPA-D***
- Type OS/80X-MPA-D***
- Type OS/80X-APA-D***
- Type OS/84X***
- Type OS/88X***
- Type OS/80X-PN***
- Type OS/84X-PN***

Temperature (Select One)

- Class 1 (-10 to 60°C / 14 to 140°F)
- Class 2 (-20 to 60°C / -4 to 140°F)

O-ring Material

Standard (-10 to 60°C / 14 to 140°F)

- Nitrile (NBR)***
- Fluorocarbon (FKM)***

Options

- Proximity Switch or Micro Switch for Remote Monitoring**
- Solenoid Valve for Remote-controlled Closure**
- IT/3V Three-Way Valve for Setting Control**

Slam-Shut Trip Pressure Setting (Select One)

- Overpressure (OPSO) trip only
Indicate Overpressure Trip Point _____
- Over and Underpressure (OPSO/UPSO) trip
Indicate Overpressure Trip Point _____
Indicate Underpressure Trip Point _____

- continued -

Type BM5A

Ordering Guide (continued)

Slam-Shut Valve Quick Order Guide	
***	Readily Available for Shipment
**	Allow Additional Time for Shipment
*	Special Order, Constructed from Non-Stocked Parts. Consult Your local Sales Office for Availability.
Availability of the product being ordered is determined by the component with the longest shipping time for the requested construction.	

Specification Worksheet	
Application:	_____
Specific Use	_____
Line Size	_____
Gas Type and Specific Gravity	_____
Gas Temperature	_____
Pressure:	
Maximum Inlet Pressure (P_{1max})	_____
Minimum Inlet Pressure (P_{1min})	_____
Downstream Pressure Setting(s) (P_2)	_____
Maximum Flow (Q_{max})	_____
Performance Required:	
Accuracy Requirements?	_____
Need for Extremely Fast Response?	_____
Other Requirements:	_____

✉ Webadmin.Regulators@emerson.com

Facebook.com/EmersonAutomationSolutions

🔍 Tartarini-NaturalGas.com

LinkedIn.com/company/emerson-automation-solutions

Twitter.com/emr_automation

Emerson Automation Solutions

Americas

McKinney, Texas 75070 USA
T +1 800 558 5853
+1 972 548 3574

Asia Pacific

Singapore 128461, Singapore
T +65 6777 8211

Europe

Bologna 40013, Italy
T +39 051 419 0611

Middle East and Africa

Dubai, United Arab Emirates
T +971 4 811 8100

D104576X012 © 2020, 2021 Emerson Process Management Regulator Technologies, Inc. All rights reserved. 09/21.

The Emerson logo is a trademark and service mark of Emerson Electric Co. All other marks are the property of their prospective owners. Tartarini™ is a mark owned by one of the companies in the Emerson Automation Solutions business unit of Emerson Electric Co.

The contents of this publication are presented for informational purposes only, and while every effort has been made to ensure their accuracy, they are not to be construed as warranties or guarantees, express or implied, regarding the products or services described herein or their use or applicability. All sales are governed by our terms and conditions, which are available upon request. We reserve the right to modify or improve the designs or specifications of such products at any time without notice.

Emerson Process Management Regulator Technologies, Inc does not assume responsibility for the selection, use or maintenance of any product. Responsibility for proper selection, use and maintenance of any Emerson Process Management Regulator Technologies, Inc. product remains solely with the purchaser.

Emerson Process Management s.r.l

Emerson Automation Solutions - Stabilimento di/Site of: Castel Maggiore - Bologna
Sede Legale/Legal Entity: Piazza Meda 5, 20121 Milano, Italy
Sede Amministrativa/Administrative Headquarters: OMT Tartarini, Via Clodoveo Bonazzi 43, 40013 Castel Maggiore (Bologna), Italy
C.F. - P.I. e R.I. di MI 13186130152 - REA di MI/n.1622916
Direz. e Coord. (art. 2497 bis CC): EMERSON ELECTRIC CO. St. Louis (USA) Socio Unico

