

# ASCO™ PINCH SOLENOID VALVE

## 2/2 NORMALLY CLOSED

**SERIES**  
**S105-10-13**

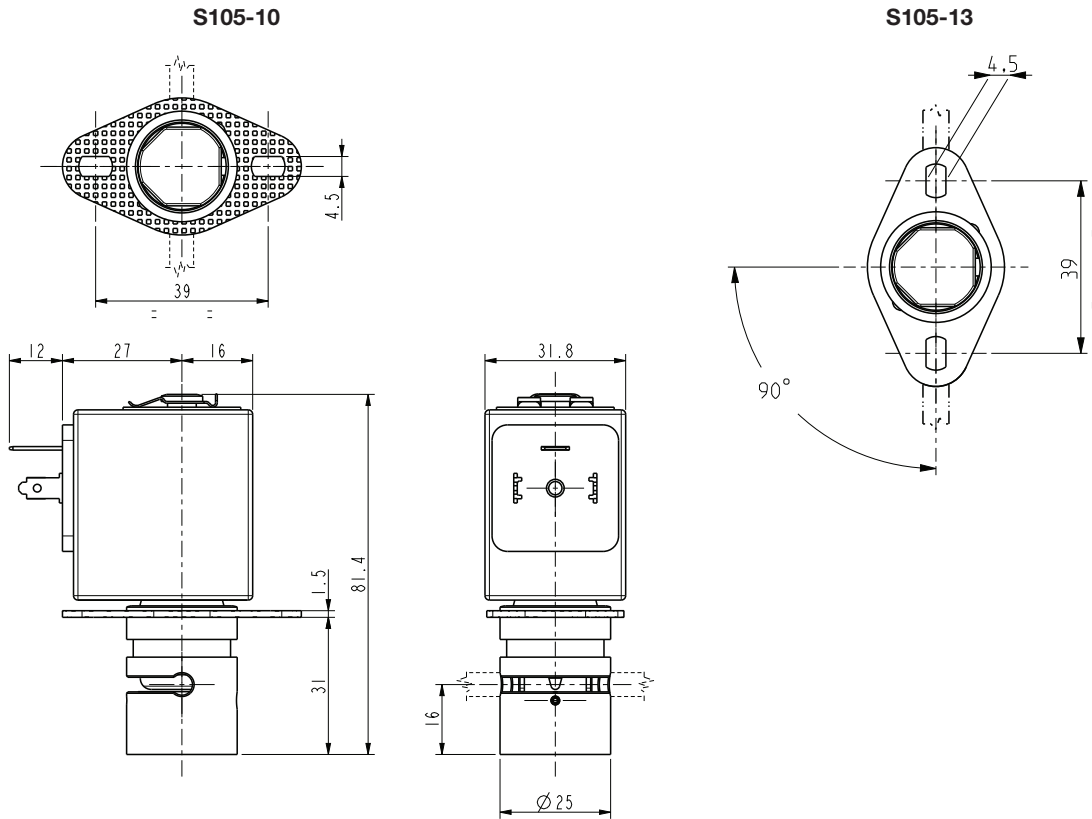

### General Features

Pinch solenoid valve, suitable to shut off media without producing neither turbulent flows nor dead spaces. High flow rate under the same conditions of internal diameter of different solenoid valves; the system allows a bi-directional through flow. The valves are suitable for soft SILICONE tubings or others, similar as to elasticity and hardness (50 shore A). Silent model.

#### The tubing is the only material in contact with the fluid.

The tubings are not included in our supply.

Materials	
Body	Anodized aluminum
Pinching device	POM (reinforced acetal copolymer)
Internal components	Stainless steel
Core tube	Chemically nickel coated brass (Ni-P)

### Installation

- Solenoid valve can be mounted in any position.

Coil	
Continuous Duty	ED 100%
Encapsulation material	PET (polyethylene terephthalate) fiberglass reinforced
Insulation class	F (140°C)
Ambient temperature	-10°C +60°C
Electric connections	DIN 46340 - 3 poles connectors (EN 175301-803)
Protection degree	IP 65 (DIN 40050) with connectors
Voltages	DC
	12-24V (+10% -5%) (Other voltages on request)

TUBINGS		Pinching strength (kg)	Series and type		Power absorption (W)	Notes	Weight (kg)
I.D. (mm)	O.D. (mm)		Valve	Coil			
3,5	5,5	0,650	S105-10 S105-13	Z530A	9	- 1	0,270

### Notes

- In case the tubing is not placed in its seat, the solenoid valve could operate incorrectly
- 1 - 90° turned clamp (see drawing)