

ASCO™ PINCH SOLENOID VALVE

2/2 NORMALLY CLOSED

SERIES
S125

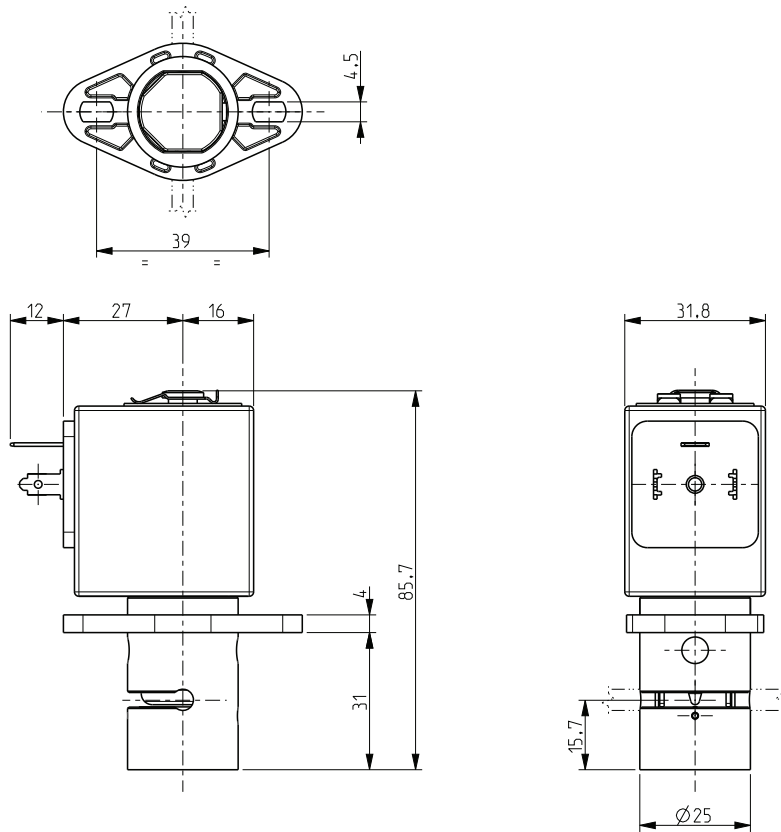

General Features

Pinch solenoid valve, suitable to shut off media without producing neither turbulent flows, nor dead spaces. High flow rate under the same conditions of internal diameter of different solenoid valves; the system allows a bi-directional through flow. The valves are suitable for soft SILICONE tubings or others, similar as to elasticity and hardness (50 shore A). Silent model.

The tubing is the only material in contact with the fluid.

The tubings are not included in our supply.

Materials	
Body	PA (Polyamide)
Pinching device	POM (reinforced acetal copolymer)
Internal components	Stainless steel
Core tube	Chemically nickel coated brass (Ni-P).

Coil	
Continuous Duty	ED 100%
Encapsulation material	PET (polyethylene terephthalate) fiberglass reinforced
Insulation class	F (140°C)
Ambient temperature	-10°C +60°C
Electric connections	DIN 46340 - 3 poles plug-connectors (EN175301-803)
Protection degree	IP 65 (DIN 40050) with plug-connectors
Voltages	DC
	12-24V (+10% -5%) (Other voltages on request)

Installation

- Solenoid valve can be mounted in any position.

TUBINGS		Pinching strength (kg)	Series and type		Power absorption (W)	Notes	Weight (kg)
I.D. (mm)	O.D. (mm)		Valve	Coil			
2,7	4,9	0,650	S125-01	Z530A	9	-	0,265
3,4	4,7						

Notes

- For the use of a soft tubing with outside diameter smaller than 3,5mm it is necessary to install the tubing guide sleeve (drawing K29501).
- In case the tubing is not placed in its seat, the solenoid valve could operate incorrectly.