

| REVISIONS | | | | | | |
|-----------|-----|-----------------------------|---------|---------|-------|-------|
| ZONE | REV | DESCRIPTION | DATE | ECN/ECO | DRAWN | APPR. |
| ALL | 01 | UPDATED PER IMPACT ANALYSIS | 1/13/23 | 104476 | JCN | HTR |

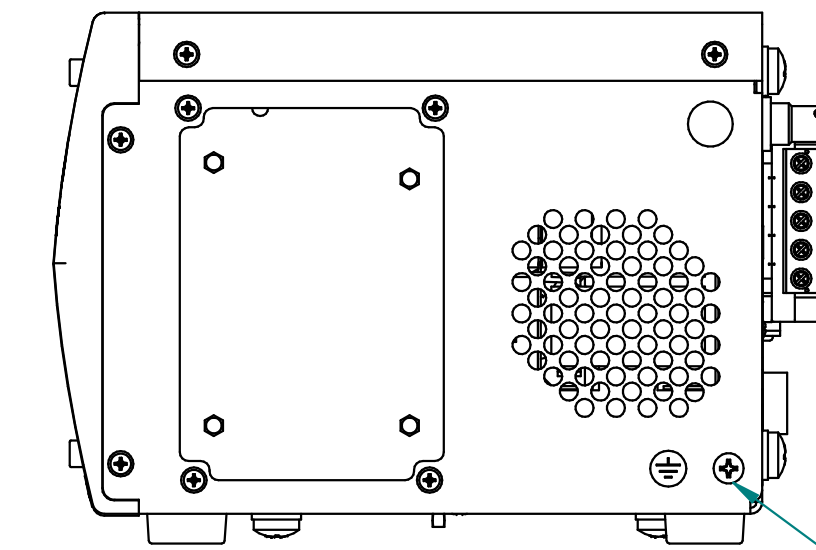

GROUND SCREW.

GROUND SCREW.

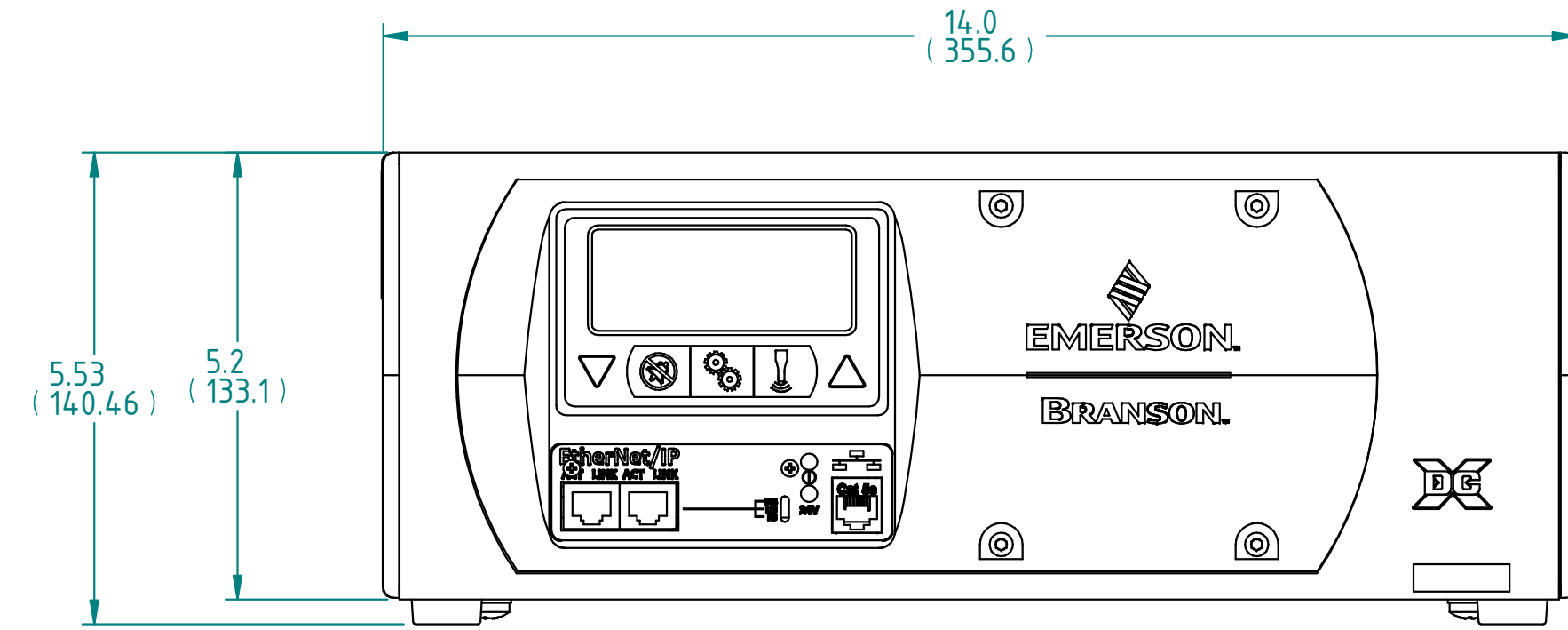
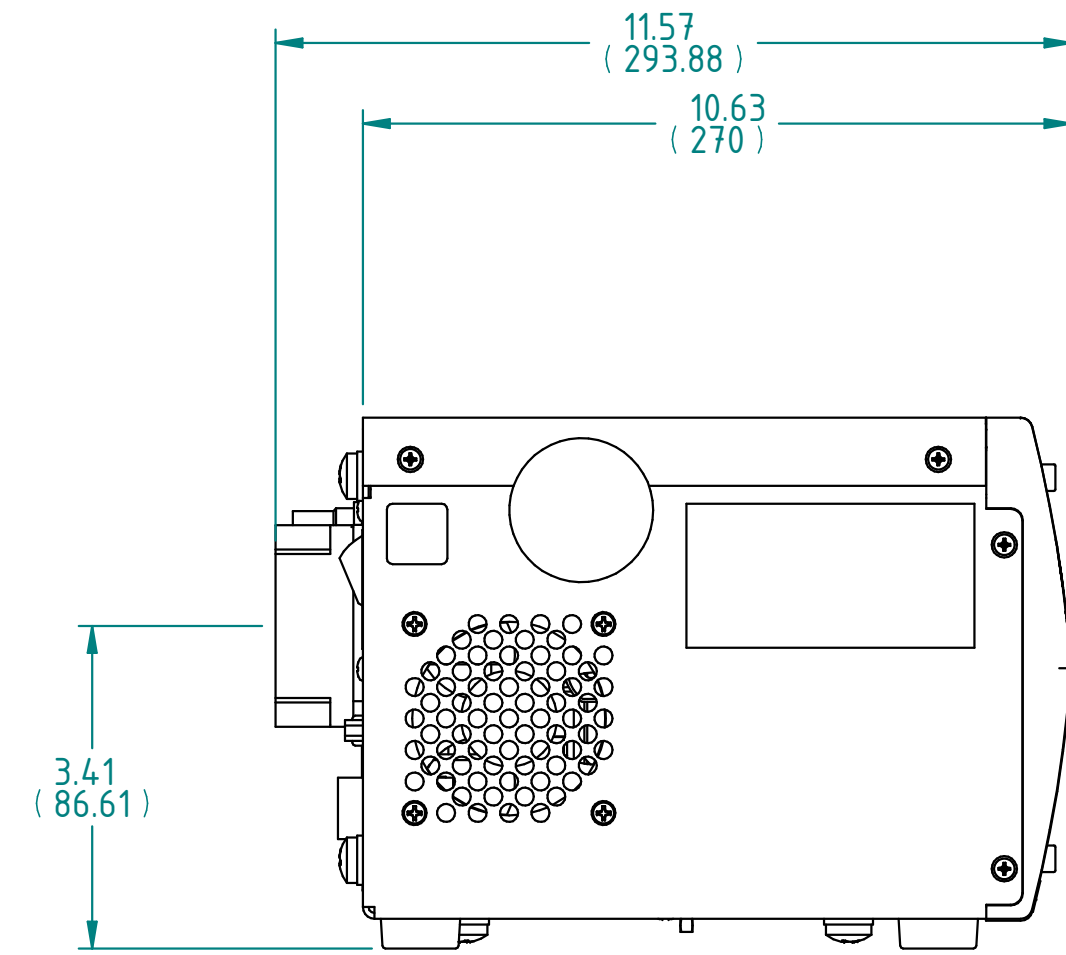
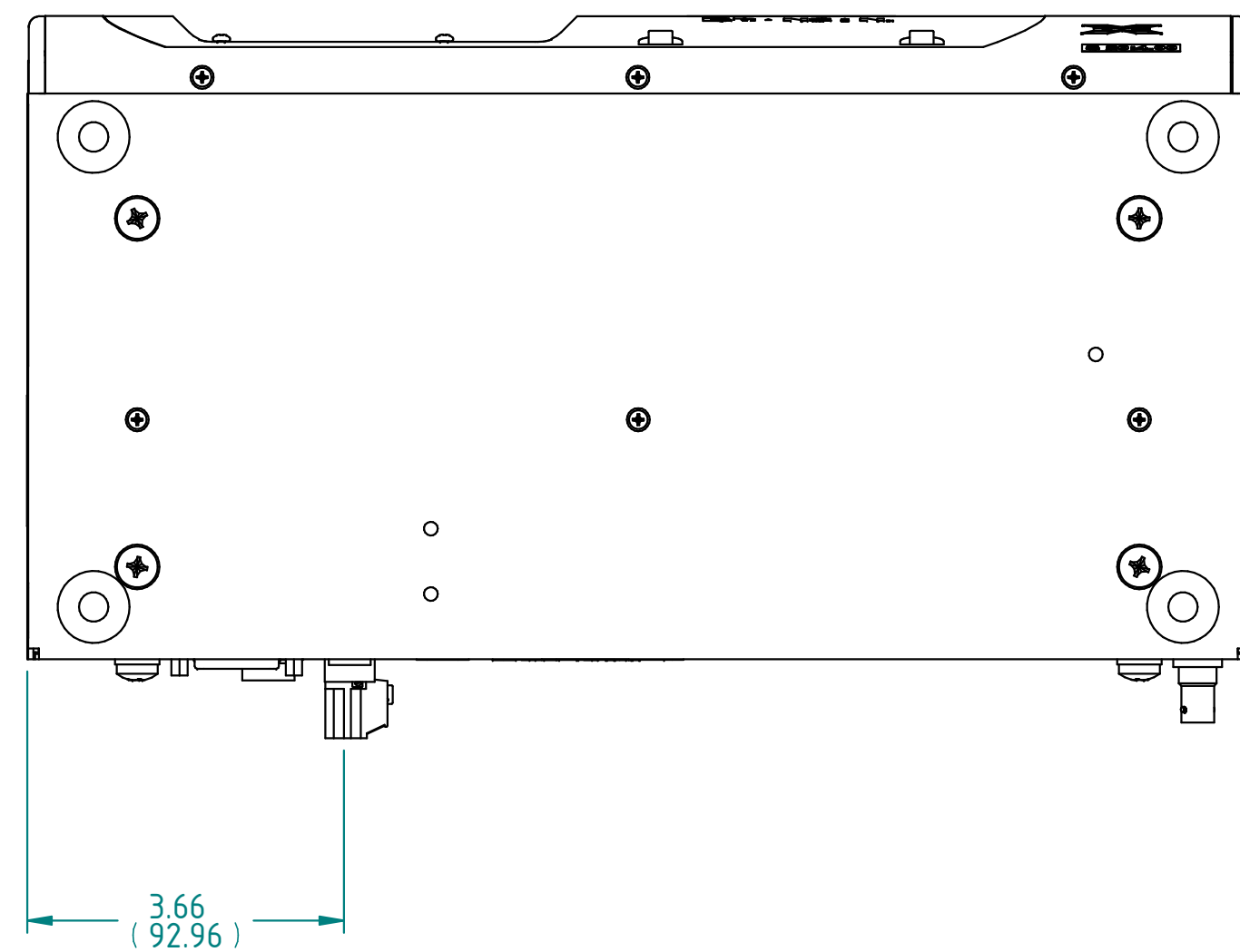
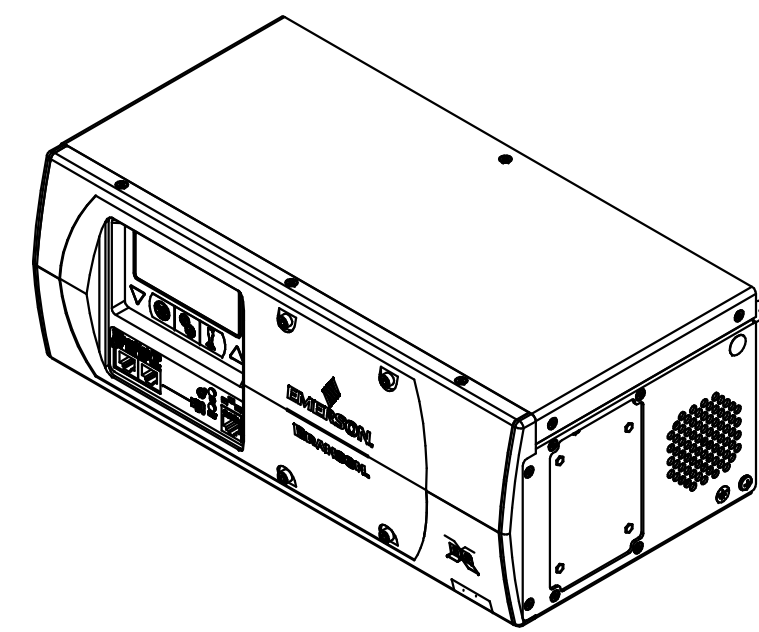

- NOTES: UNLESS OTHER SPECIFIED
1. ALL DIMENSIONS ARE APPROXIMATE.
 2. 3.0in (76mm) RECOMMENDED CLEARANCE ON BOTH SIDES FOR THE FAN.
 3. 5.0in (127mm) RECOMMENDED CLEARANCE IN THE BACK FOR CABLES.

| <small>UNLESS OTHERWISE SPECIFIED DIMENSIONS ARE IN INCHES AND TOLERANCES ARE: 2 PLACE DECIMALS ±0.05 3 PLACE DECIMALS ±0.005 4 PLACE DECIMALS ±0.0005 ANGLES ±1° FRACTIONS 1/32 SURFACE FINISH</small> GD & T Standard ASME Y 14.5 <small>SECONDARY DIMENSIONS ARE PROVIDED FOR REFERENCE ONLY</small> | <small>This PROPRIETARY Document is property of Branson Ultrasonics Corp., Brookfield, CT. It is confidential in nature, non-transferable, and issued with the clear understanding that it is not traced or copied without permission and is returnable upon demand.</small> | | <small>MATERIAL:</small> N/A | | BRANSON | | | | | | | | | | | | | |
|--|--|--|-----------------------------------|------|--|---------|--------|---------|----------------------|---------|--|---------------------------|-----------------------------------|---|----------------------------------|--------------|-----------------------|-----------|
| | <small>Article or material must comply with requirements stipulated by RoHS in its current version.</small> | | <small>Material Spec.</small> N/A | | <table border="1"> <tr> <th colspan="2">TITLE</th> </tr> <tr> <td colspan="2">OUTLINE DCX A HOR LG</td> </tr> <tr> <td><small>AGENCY PART</small></td> <td>NO</td> </tr> <tr> <td><small>BUC CLASSIFICATION</small></td> <td>3 Important</td> </tr> <tr> <td><small>IP CLASSIFICATION</small></td> <td>NO</td> </tr> <tr> <td><small>WEIGHT</small></td> <td>0.000 lbm</td> </tr> </table> | | TITLE | | OUTLINE DCX A HOR LG | | <small>AGENCY PART</small> | NO | <small>BUC CLASSIFICATION</small> | 3 Important | <small>IP CLASSIFICATION</small> | NO | <small>WEIGHT</small> | 0.000 lbm |
| | TITLE | | | | | | | | | | | | | | | | | |
| | OUTLINE DCX A HOR LG | | | | | | | | | | | | | | | | | |
| <small>AGENCY PART</small> | NO | | | | | | | | | | | | | | | | | |
| <small>BUC CLASSIFICATION</small> | 3 Important | | | | | | | | | | | | | | | | | |
| <small>IP CLASSIFICATION</small> | NO | | | | | | | | | | | | | | | | | |
| <small>WEIGHT</small> | 0.000 lbm | | | | | | | | | | | | | | | | | |
| <small>3RD ANGLE PROJECTION</small> | <small>FINISH:</small> N/A | <table border="1"> <tr> <th>NAME</th> <th>DATE</th> </tr> <tr> <td>dsulik</td> <td>3/08/13</td> </tr> <tr> <td>ngaler</td> <td>3/08/13</td> </tr> <tr> <td>dsulik</td> <td>3/08/13</td> </tr> </table> | NAME | DATE | dsulik | 3/08/13 | ngaler | 3/08/13 | dsulik | 3/08/13 | <table border="1"> <tr> <td><small>SCALE:</small> 1:2</td> <td><small>SHEET 1 OF 1</small></td> </tr> </table> | <small>SCALE:</small> 1:2 | <small>SHEET 1 OF 1</small> | <table border="1"> <tr> <td>D</td> <td>931-132-1823</td> <td>REV 01</td> </tr> </table> | D | 931-132-1823 | REV 01 | |
| NAME | DATE | | | | | | | | | | | | | | | | | |
| dsulik | 3/08/13 | | | | | | | | | | | | | | | | | |
| ngaler | 3/08/13 | | | | | | | | | | | | | | | | | |
| dsulik | 3/08/13 | | | | | | | | | | | | | | | | | |
| <small>SCALE:</small> 1:2 | <small>SHEET 1 OF 1</small> | | | | | | | | | | | | | | | | | |
| D | 931-132-1823 | REV 01 | | | | | | | | | | | | | | | | |
| <small>Finish Spec.</small> N/A | - | - | - | | | | | | | | | | | | | | | |

SOLID EDGE