

Systembeschreibung | System description | Description du système
Descrizione del sistema | Descripción de sistema | Systembeskrivning

R412028957-BAL-001-AB
2024-04; Replaces: 2023-11
DE/EN/FR/IT/ES/SV

AVENTICS™ AF2

Durchflusssensor
Flow sensor
Capteur de débit
Flussometro
Sensor de caudal
Flödessensor



Inhaltsverzeichnis

1	Zu dieser Dokumentation	3
1.1	Gültigkeit der Dokumentation	3
1.2	Zusätzliche Dokumentationen	3
1.3	Verwendete Abkürzungen	3
2	Sicherheit	3
2.1	Zu diesem Kapitel	3
3	Daten und Parameter	3
3.1	Hinweise zur Sicherheit	3
3.2	Parameterdaten	3
3.2.1	Allgemeine Einstellungen	3
3.2.2	Einstellungen für Variante IO-Link	6
3.2.3	Einstellungen für Variante Ethernet	8

1 Zu dieser Dokumentation

Diese Anleitung enthält wichtige Informationen für den sicheren und sachgerechten Umgang mit dem Produkt.

Diese Dokumentation ist eine Ergänzung zur mitgelieferten Montageanleitung. Lesen Sie die Montageanleitung vollständig, bevor Sie mit dem Produkt arbeiten.

1.1 Gültigkeit der Dokumentation

Diese Dokumentation richtet sich an:

Programmierer, Servicepersonal, Anlagenbetreiber

Diese Dokumentation liefert ergänzende Informationen im Umgang mit folgenden Produktvarianten der Serie AF2 und 652/653:

Serie	Produktvariante	Schnittstelle
AF2	Sensorfilterkombination (AS)	IO-Link
		Ethernet
	Sensor High Flow (HF)	IO-Link
		Ethernet
652	Filter-Produktvariante	IO-Link (A)
		Ethernet (B)
	Rohr-Produktvariante	IO-Link (A)
		Ethernet (B)
653	Filter-Produktvariante	IO-Link (A)
		Ethernet (B)
	Rohr-Produktvariante	IO-Link (A)
		Ethernet (B)

1.2 Zusätzliche Dokumentationen

Beachten Sie folgende mitgelieferte Dokumentationen:

- Anlagendokumentation des Herstellers
- Dokumentation übriger Anlagenkomponenten
- Montageanleitung (R412026496 oder 549411)

1.3 Verwendete Abkürzungen

In dieser Dokumentation werden folgende Abkürzungen verwendet:

Abkürzung	Bedeutung
ABS	Acrylnitril-Butadien-Styrol
GF	Glasfaser
HF	High Flow
MBE	Messbereichsendwert
MQTT	Message Queuing Telemetry Transport
MTTF	Mean Time To Failure (mittlere Betriebsdauer bis zum Ausfall)
NPT	National Taper Pipe (Rohrgewindetyp)
OLED	Organic Light Emitting Diode (organische Leuchtdiode)
OPC UA	Open Platform Communications Unified Architecture
PA	Polyamid
PC	Polycarbonat
PSA	Persönliche Schutzausrüstung
Pt	Platin-Messwiderstand

2 Sicherheit

2.1 Zu diesem Kapitel

- Lesen Sie das Kapitel Sicherheit der Montageanleitung sowie die gesamte Dokumentation gründlich und vollständig, bevor Sie mit dem Produkt arbeiten.
- Bewahren Sie die Dokumentation so auf, dass sie jederzeit für alle Benutzer zugänglich ist.

3 Daten und Parameter

3.1 Hinweise zur Sicherheit

- Keine Parameteränderungen im laufenden Betrieb vornehmen (Verletzungsprävention).

3.2 Parameterdaten

3.2.1 Allgemeine Einstellungen

Die Einstellung der Parameter in diesem Abschnitt gilt für alle Varianten des Produkts.

Allgemein

Ziel	Menü	Option
Einstellungen vornehmen	Standardanzeige	Eine beliebige Pfeiltaste mind. 2 Sekunden lang drücken und im jeweiligen Menü Einstellungen vornehmen.

Display

Ziel	Untermenü	Option
Einheiten einstellen	Units	Zwischen folgenden Menüs wählen: <ul style="list-style-type: none">MassFlowRateFlowVelocityVolumeVolFlowRateMassEnergyTemperaturePressure
Anzeige Screen 1.1 einstellen	Pages	<ul style="list-style-type: none">Disp1Top auswählenDisp1Btm auswählen
Anzeige Screen 1.2 einstellen	Pages	<ul style="list-style-type: none">Disp2Top auswählenDisp2Btm auswählen
Anzeige Screen 1.3 einstellen	Pages	<ul style="list-style-type: none">Disp3Top auswählenDisp3Btm auswählen
Anzeige Screen 2.1, 2.2 und 2.3 einstellen	Pages	Im Menü DispHistory Anzeigeparameter auswählen
Lesbarkeit optimieren	Rotation	Anzeige 0°, 90°, 180° oder 270° einstellen
Aktivieren des Bildschirmschoners	ScreenSaver	Zeit für Aktivierung des Bildschirmschoners einstellen
Abschalten des Displays	AutoOff	Zeit für Abschalten des Displays einstellen
Helligkeit einstellen	Brightness	Helligkeit in Prozent einstellen
Pin für Bedienschutz bzw. Manipulationsschutz vergeben	Display Pin	4-stellige Pin vergeben



Abb. 1



Abb. 2

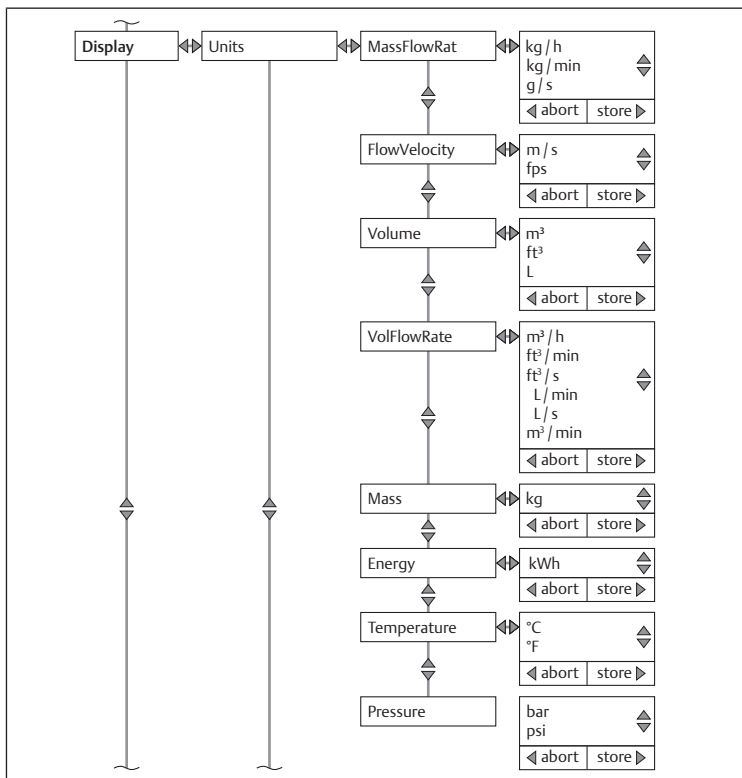

Abb. 3

Simulate

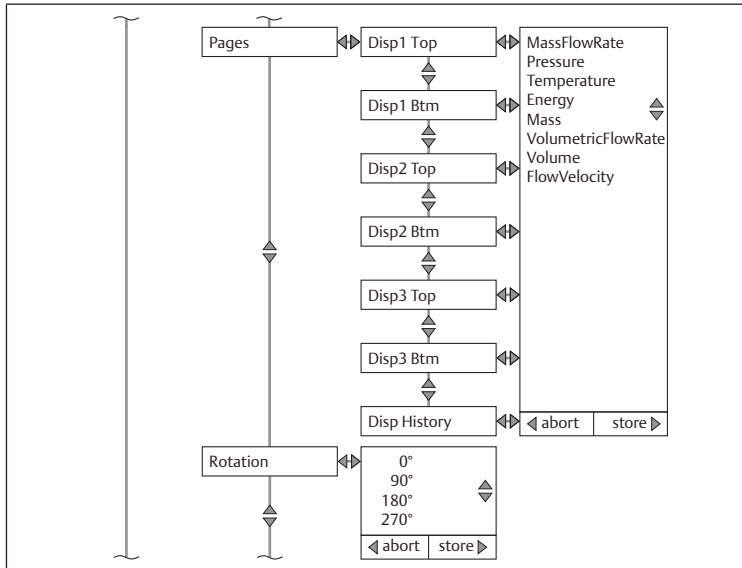
Ziel	Untermenü	Option
Durchfluss simulieren	Flow	Durchfluss simulieren
Temperatur simulieren	Temperature	Temperatur simulieren
Druck simulieren	Pressure	Druck simulieren

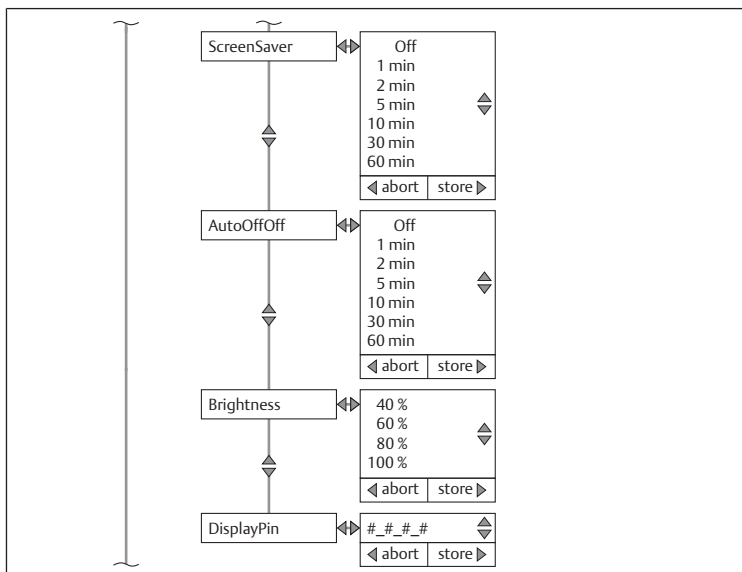

Abb. 4

Measure

Ziel	Untermenü	Option
Messmedium einstellen	Flow	Option Medium auswählen und Messmedium einstellen: <ul style="list-style-type: none"> • Air • Argon • CO2 • Nitrogen

Referenznorm/Referenzstandard einstellen	Flow	Option RefCond auswählen und Referenznorm/Referenzstandard einstellen: <ul style="list-style-type: none"> • ISO2533 • ISO1217 • DIN1945-1 • DIN1343 • ISO6358 • ISO8778 • UserDefined (anwendungsspezifisch)
--	------	--

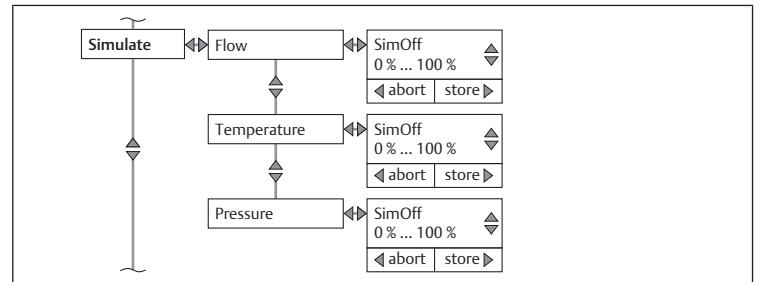
Referenzdruck bei anwendungsspezifischer Einstellung (UserDefined) einstellen	Flow	Option RefCond auswählen und UserDefined (Referenzdruck anwendungsspezifisch) auswählen
---	------	--

Nullpunktverschiebung einstellen	Flow	Option 0-FlowOff auswählen und Nullpunktverschiebung einstellen
----------------------------------	------	--

Schleichmengenunterdrückung einstellen	Flow	Option 0-FlowCut auswählen und Schleichmengenunterdrückung einstellen
--	------	--

Mittelwertsfilter für Messwertglättung an Anzeige und Ausgang	Flow/Pressure/Temperature	Option Filter auswählen und Messwertfilter einstellen
---	---------------------------	--

Offset/Nullpunktverschiebung einstellen	Pressure/Temperature	Option Offset auswählen und Offset/Nullpunktverschiebung einstellen
---	----------------------	--

Signalqualität wählen	SigQuality	Zwischen SigQua1 , SigQua2 , SigQua3 und SigQua4 auswählen. Qualität ist jeweils auf 100 % eingestellt. Signalqualität 1 ist ein Maß für Robustheit
-----------------------	------------	---



Abb. 5



Abb. 6

History

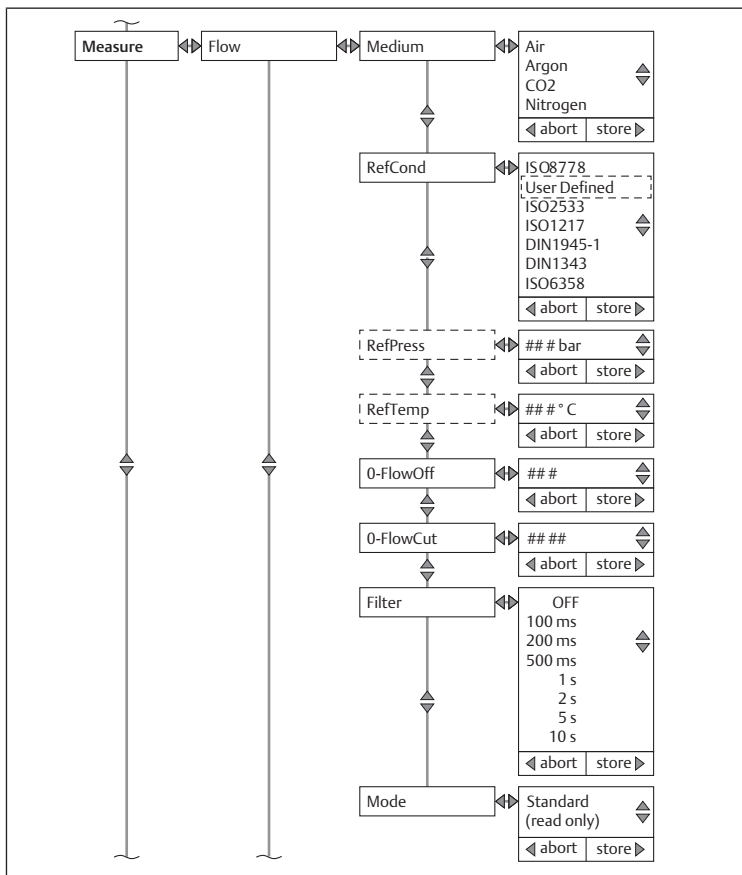
Ziel	Untermenü	Option
Anzeige/Graph der Messwerte der letzten 60 Minuten wählen	60 min	Anzeige/Graph der Messwerte letzten 60 Minuten auswählen

Ziel	Untermenü	Option
Anzeige/Graph der Messwerte der letzten 24 Stunden wählen	24 hour	Anzeige/Graph der Messwerte der letzten 24 Stunden auswählen
Anzeige/Graph der Messwerte der letzten 7 Tage wählen	7 days	Anzeige/Graph der Messwerte der letzten 7 Tage auswählen

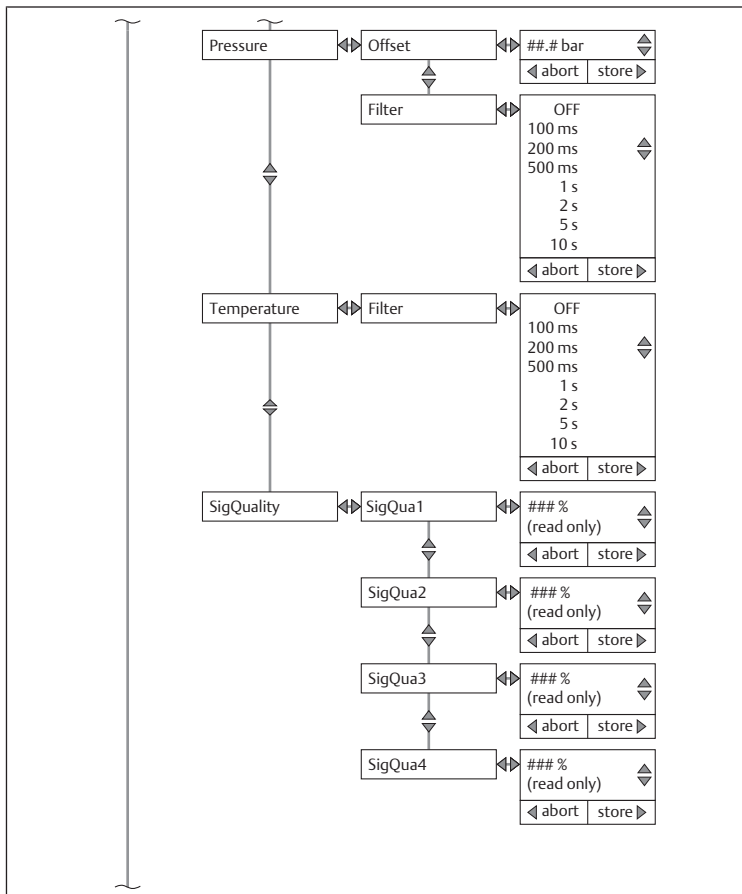

Abb. 7

Statistics

Ziel	Untermenü	Option
Mindestwerte, Mittelwerte und Maximalwerte der einzelnen Parameter nach dem letzten Reset	View	Max, mean, min values der einzelnen Parameter nach dem letzten Reset anzeigen
Zeitpunkt des letzten Resets anzeigen (read only)	LastReset	Zeitpunkt des letzten Resets anzeigen
Statistikwerte auf 0 zurücksetzen	Reset	Statistikwerte auf 0 zurücksetzen

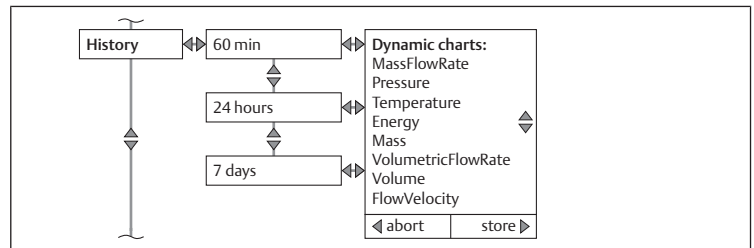

Abb. 8

Counter

Ziel	Untermenü	Option
Zähler anzeigen		Zwischen Untermenüs Mass, Volume, Energy und LastReset wählen und Zähler anzeigen
Zähler zurücksetzen	Reset	Zähler zurücksetzen

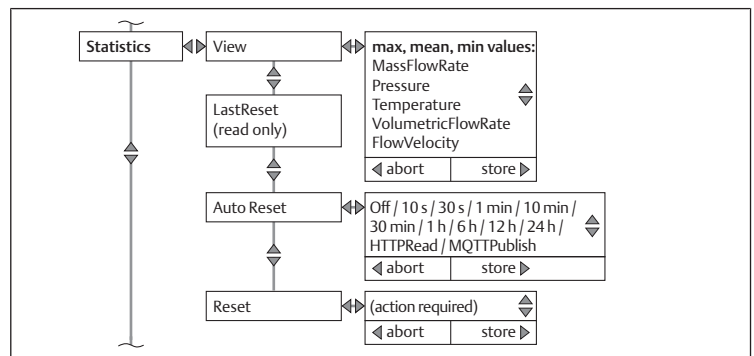

Abb. 9

System

Ziel	Untermenü	Option
Service-Login	Service	Service-Login für autorisierte Anwender vornehmen

Ziel	Untermenü	Option
Auf Werkseinstellung zurücksetzen	FactReset	System auf Werkseinstellung zurücksetzen
Serial Number (read only)	SerialNumber	Seriennummer anzeigen lassen
Device-Tag einstellen	DevTag	Device-Tag einstellen
Application-Tag einstellen	AppTag	Application-Tag einstellen
FWVersion (read only)	FWVersion	Firmwareversion anzeigen lassen
Calibration (read only)	Calibration	Firmware-Defaults anzeigen lassen
BLVersion (read only)	BLVersion	Bootloadversion anzeigen lassen
HWVersion (read only)	HWVersion	Hardwareversion anzeigen lassen

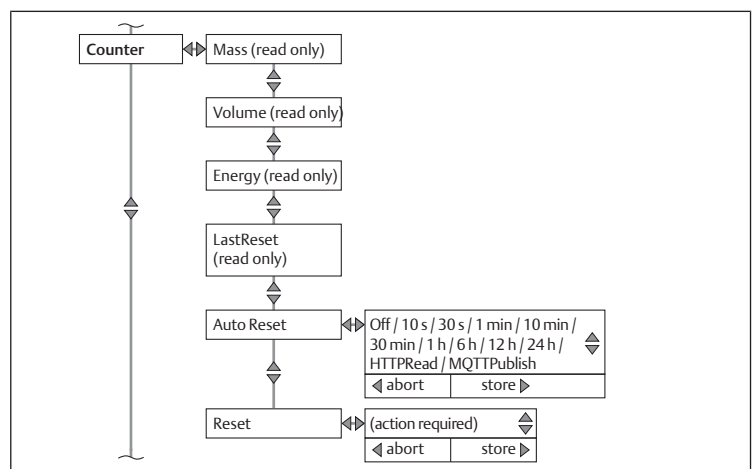

Abb. 10

Tags

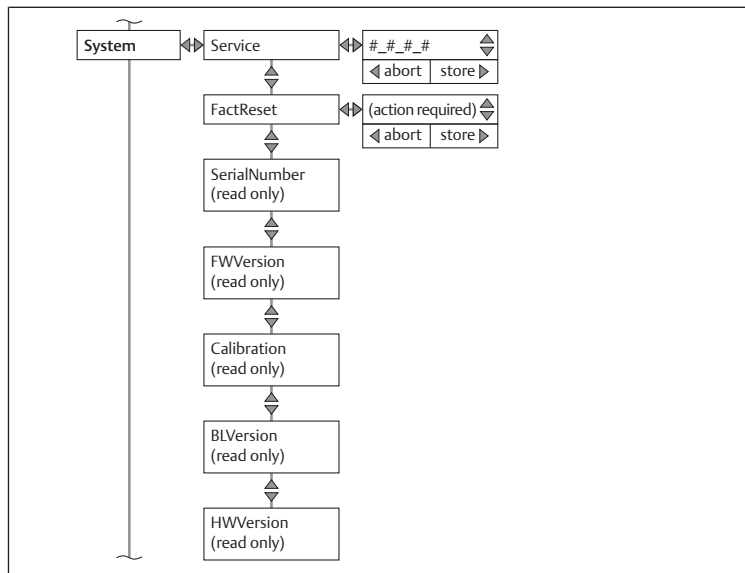

Abb. 11

3.2.2 Einstellungen für Variante IO-Link

Die Einstellungen gelten für alle Varianten des Produkts mit dem elektrischen Anschluss IO-Link.

IO-Link

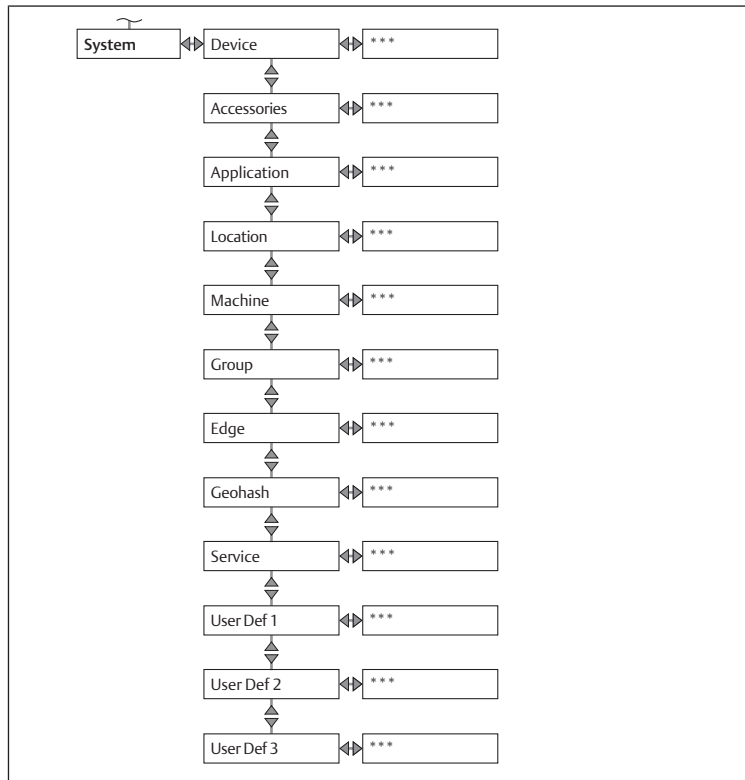
Das Display zeigt das Messwertmenü mit der Default-Einstellung an (kg/h, m/s).

Ziel	Menü	Option
Menü wählen	Standardanzeige	Eine beliebige Pfeiltaste mind. 2 Sekunden lang drücken und zwischen <i>Q1 Menu</i> , <i>Q2 Menu</i> und <i>Qa Menu</i> wählen.
Schaltausgang einstellen	Q1 Menu	Schaltausgang einstellen
Schaltausgang einstellen	Q2 Menu	Schaltausgang einstellen
Analogausgang einstellen	Qa Menu	Analogausgang einstellen

Q1 Menu

Das Q1-Menü enthält die Einstellungen des Schaltausgangs 1.

Ziel	Untermenü	Option
Einstellen der Hysterese oder Fensterfunktion	Mode	Einstellung des Modus für Hysterese oder Fensterfunktion mit den zugehörigen Messparametern vornehmen
Schaltpunkt einstellen	SetPoint1	Schaltpunkt einstellen
Rückschaltpunkt/Hysterese bzw. untere Fenstergrenze einstellen	SetPoint2	Rückschaltpunkt/Hysterese bzw. untere Fenstergrenze einstellen
Schaltverhalten des Öffners einstellen	Polarity	Zwischen <i>NormallyClosed</i> und <i>NormallyOpen</i> wählen
Schaltausgang simulieren	Simulate	<i>Active</i> , <i>Inactive</i> oder <i>Normal</i> (Messbetrieb) wählen
PNP/NPN oder Push/Pull (DRV) einstellen	DriverType	<i>PNP/NPN</i> oder <i>Push/Pull (DRV)</i> einstellen



Abb. 12

Q2 Menu

Das Q2-Menü enthält die Einstellungen des Schaltausgangs 2.

Ziel	Untermenü	Option
Schaltausgang als Schaltausgang, Frequenz, Puls oder Analog einstellen	Function	Schaltausgang als <i>Switch</i> , <i>Frequency</i> , <i>Pulse</i> oder <i>Analog</i> einstellen
Modus für Hysterese oder Fensterfunktion einstellen	Mode	Modus für Hysterese oder Fensterfunktion einstellen
Schaltpunkt einstellen	SetPoint1	Schaltpunkt einstellen

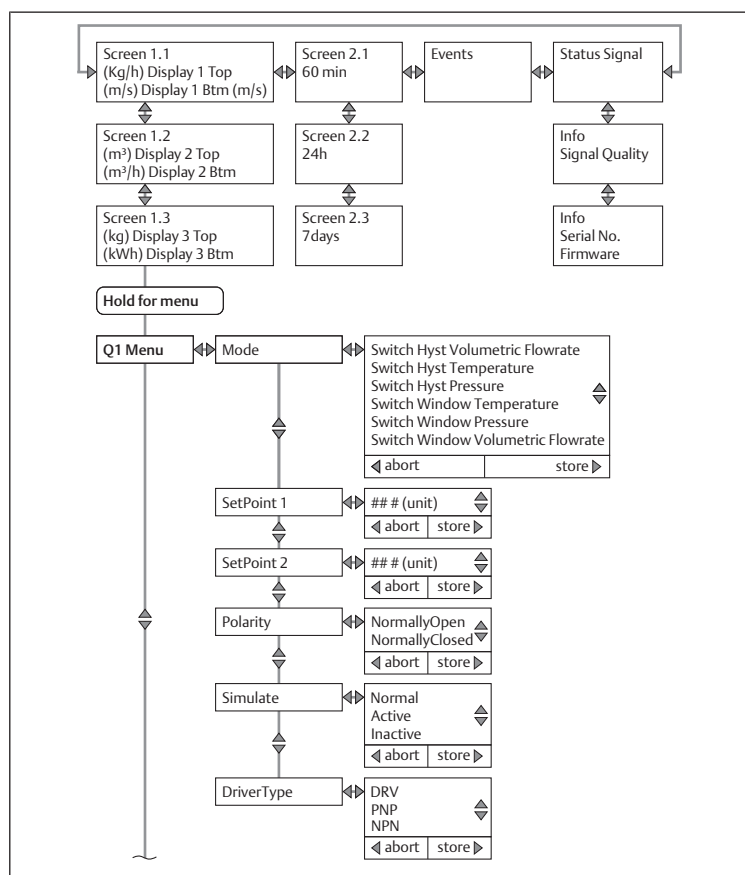
Ziel	Untermenü	Option
Rückschaltpunkt/Hysteresis bzw. untere Fenstergrenze einstellen	SetPoint2	Rückschaltpunkt/Hysteresis bzw. untere Fenstergrenze einstellen
Schaltverhalten des Öffners einstellen	Polarity	Zwischen <i>NormallyClosed</i> und <i>NormallyOpen</i> wählen
Schaltausgang simulieren	Simulate	Zwischen <i>Active</i> , <i>Inactive</i> und <i>Normal</i> (Messbetrieb) wählen
PNP/NPN oder Push/Pull einstellen	DriverType	<i>PNP/NPN</i> oder <i>Push/Pull</i> einstellen



Abb. 13



Abb. 14

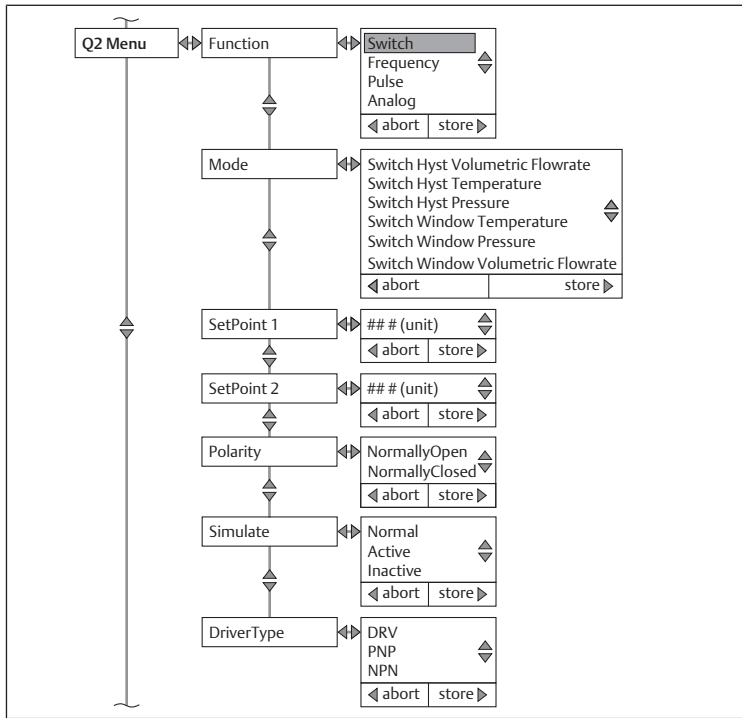

Abb. 15

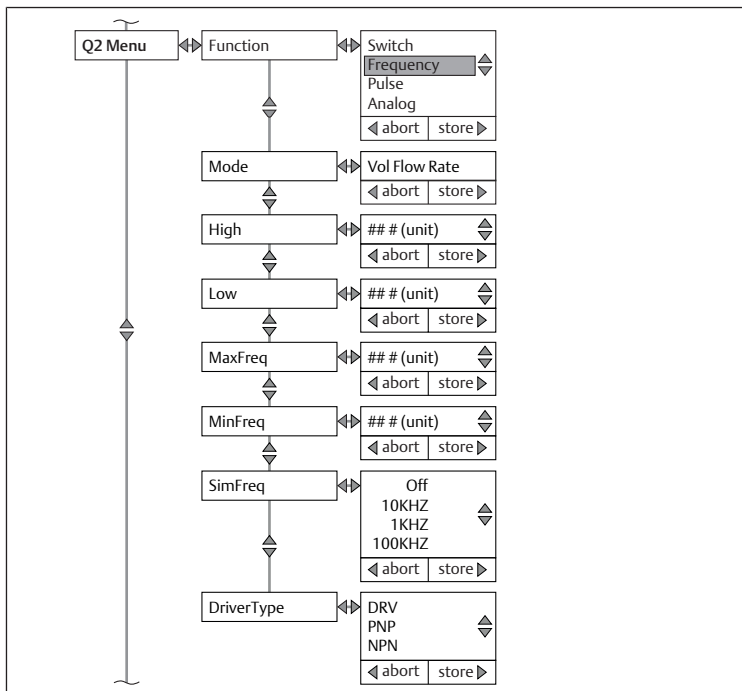

Abb. 16

Qa Menü

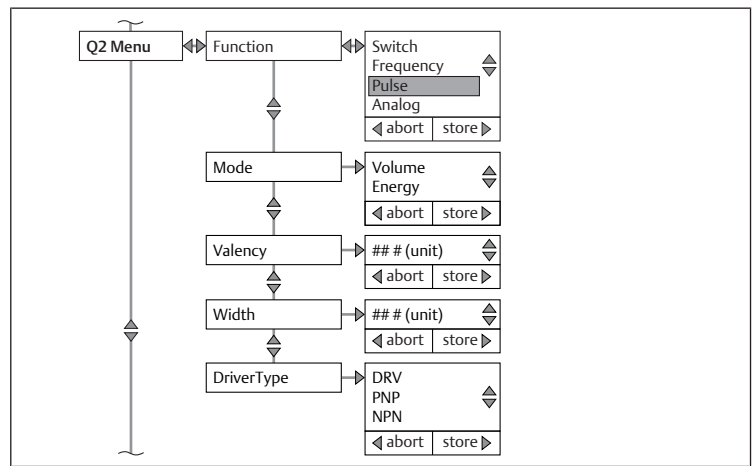
Das Qa-Menü enthält die Einstellungen des Analogausgangs.

Ziel	Untermenü	Option
Stromausgang Messparameter zuordnen	Mode	Messparameter wie Durchfluss, Temperatur oder Druck dem Stromausgang zuordnen
Messbereichsendwert zuordnen	High	Messbereichsendwert auf 20 mA setzen
Messbereichsanfang zuordnen	Low	Messbereichsanfang auf 4 mA setzen
Invertierung des Stromausgangs einstellen	Polarity	Invertierung des Stromausgangs einstellen
Verhalten des Stromausgangs bei einem Fehler am Produkt einstellen	Fail	Verhalten des Stromausgangs bei einem Fehler am Produkt einstellen
Vordefinierten Stromwert einstellen	Simulate	Vordefinierten Stromwert einstellen

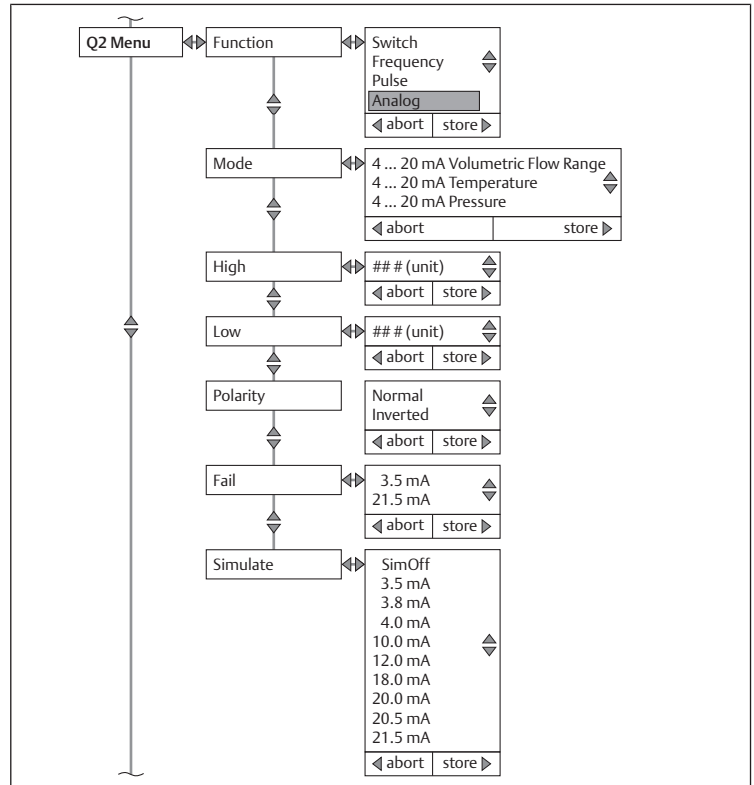

Abb. 17

3.2.3 Einstellungen für Variante Ethernet

Die Einstellungen gelten für alle Varianten des Produkts mit dem elektrischen Anschluss Ethernet.

Ethernet

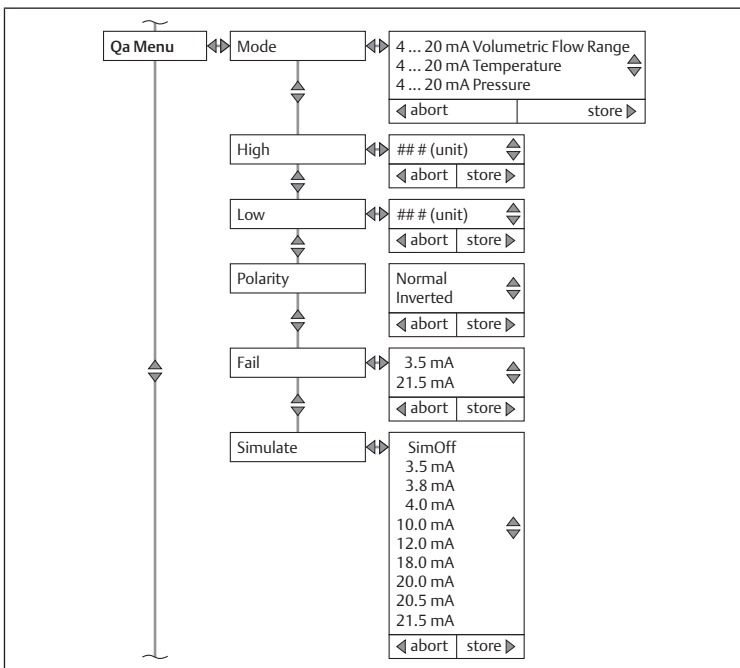
Ziel	Untermenü	Option
Statische oder dynamische Adresse zuweisen	DHCP Mode	Adresse zuweisen
IP-Adresse einstellen	IP Address	IP-Adresse einstellen
SubNetMask	SubNetMask	SubNetMask einstellen
Gateway	Gateway	Gatewayadresse einstellen
Name	Name	DHCP-Namen einstellen



Abb. 18

SNTP

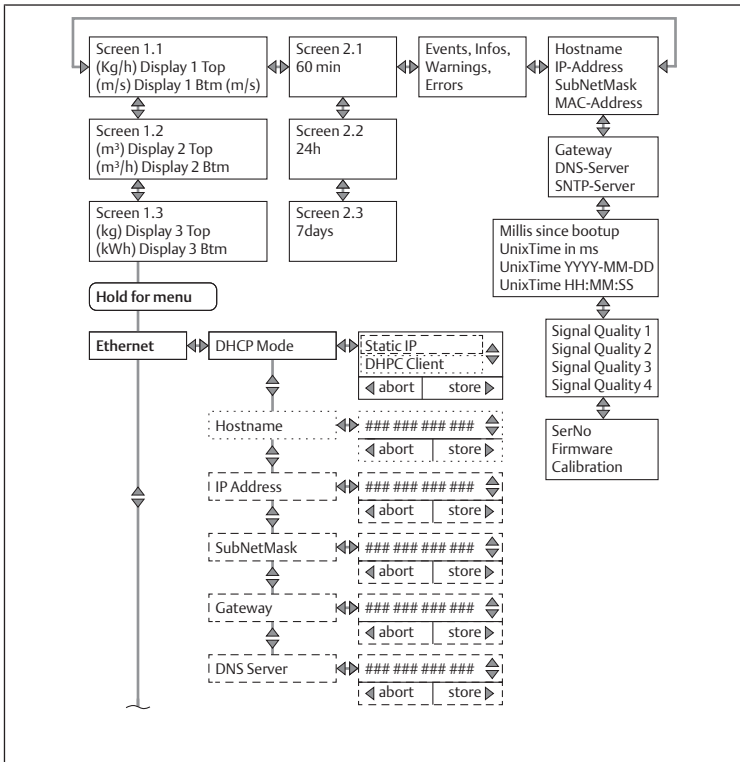
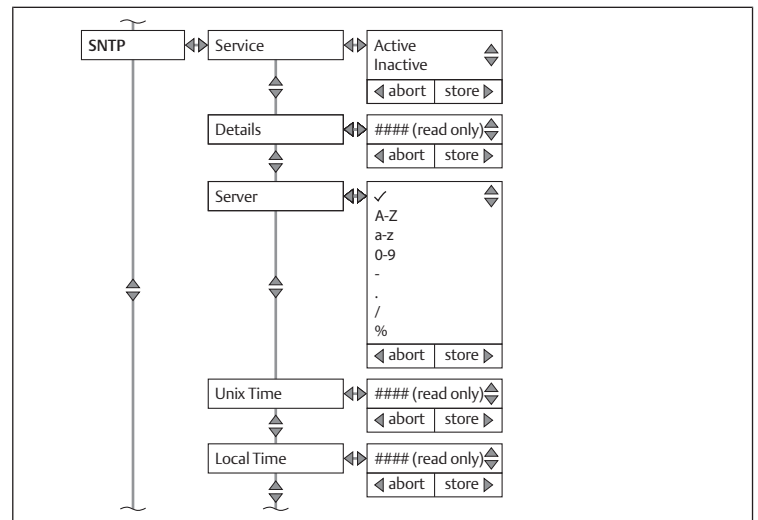

Webserver

Ziel	Untermenü	Option
Webschnittstelle einschalten und ausschalten	State	Zwischen <i>Active</i> und <i>Inactive</i> wählen
Port einstellen	Port	Webserver-Port auswählen. Der Standardport für den HTTP-Dienst ist Port 80
Anwenderseitiges Passwort zurücksetzen	ResetPW	Webserverpasswort für den Anwender „Maintenance“ auf den Auslieferungszustand zurücksetzen. Das Defaultkennwort (Werkseinstellung) lautet „airflowsensor“



Abb. 19

OPC UA

Ziel	Untermenü	Option
Webschnittstelle ein- und ausschalten	State	Zwischen <i>Active</i> und <i>Inactive</i> wählen
Port einstellen	Port	Port einstellen
Username einstellen	User	Usernamen einstellen
Passwort vergeben	Password	Passwort einstellen

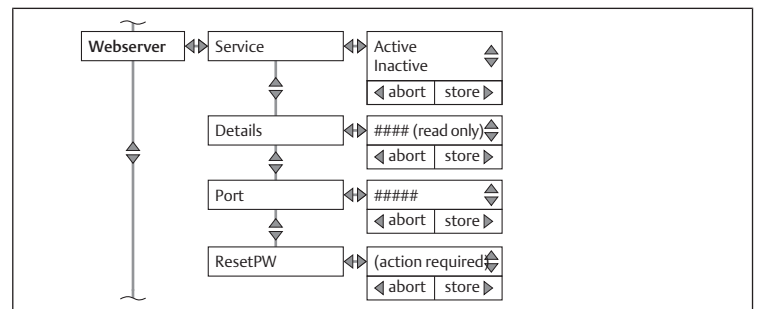

Abb. 20

MQTT

Ziel	Untermenü	Option
Webschnittstelle ein- und ausschalten	State	Zwischen <i>Active</i> und <i>Inactive</i> wählen
Broker	Broker	Broker einstellen
Port einstellen	Port	Port einstellen
Topic	Topic	Topics anzeigen
User	User	Usernamen für Broker eingeben
Broker-Passwort erstellen	Password	Broker-Passwort eingeben
Schnittintervall an Broker senden	Update	Schnittintervall setzen
QoS	QoS	<i>QoS-0</i> , <i>QoS-1</i> oder <i>QoS-2</i> auswählen
MQTT-Nachricht an den Broker definieren	Send	Menüpunkt aus zweitem Untermenü wählen und <i>Active</i> oder <i>Inactive</i> einstellen

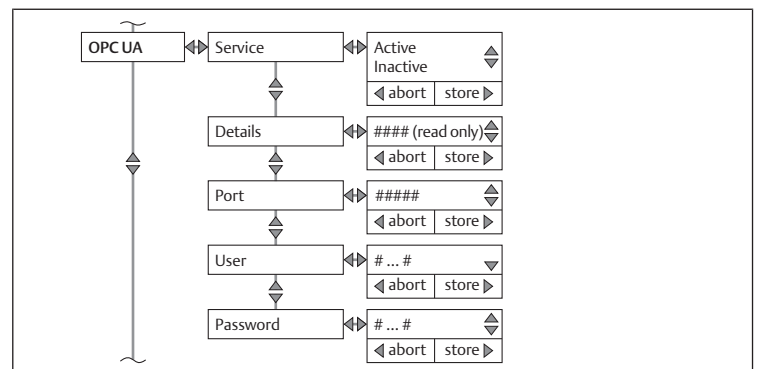

Abb. 21



Abb. 22

Table of contents

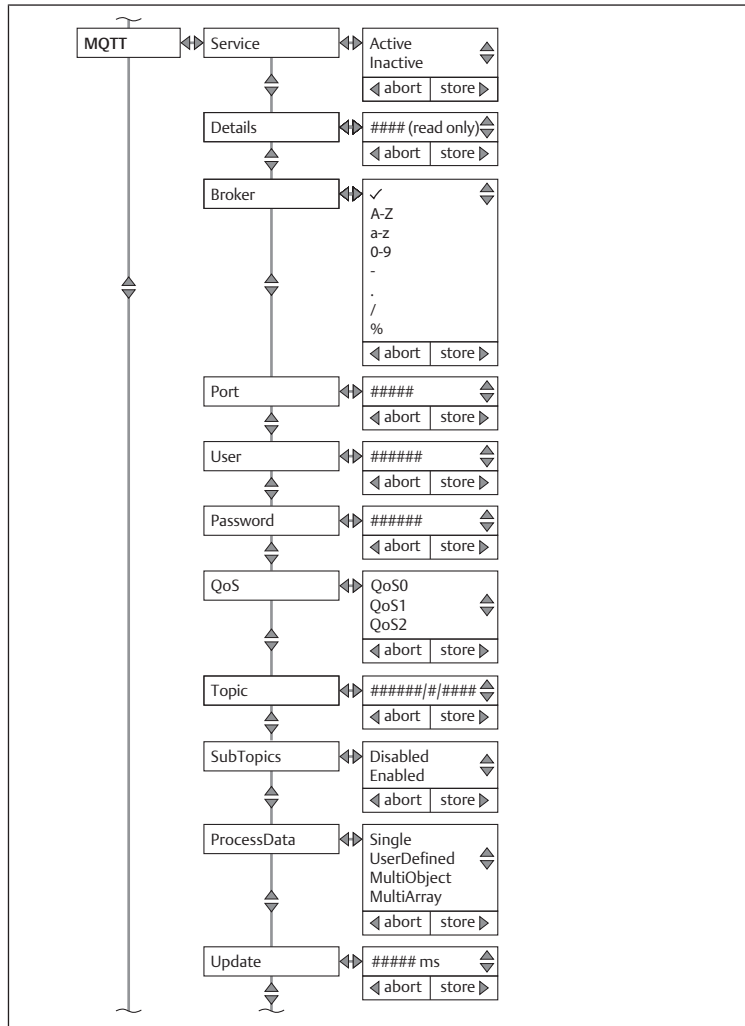
1	About this documentation	11
1.1	Documentation validity	11
1.2	Additional documentation	11
1.3	Abbreviations used	11
2	Safety	11
2.1	About this chapter	11
3	Data and parameters	11
3.1	Notes on safety	11
3.2	Parameter data	11
3.2.1	General settings	11
3.2.2	Settings for the IO-Link variant	14
3.2.3	Settings for the Ethernet variant	16

1 About this documentation

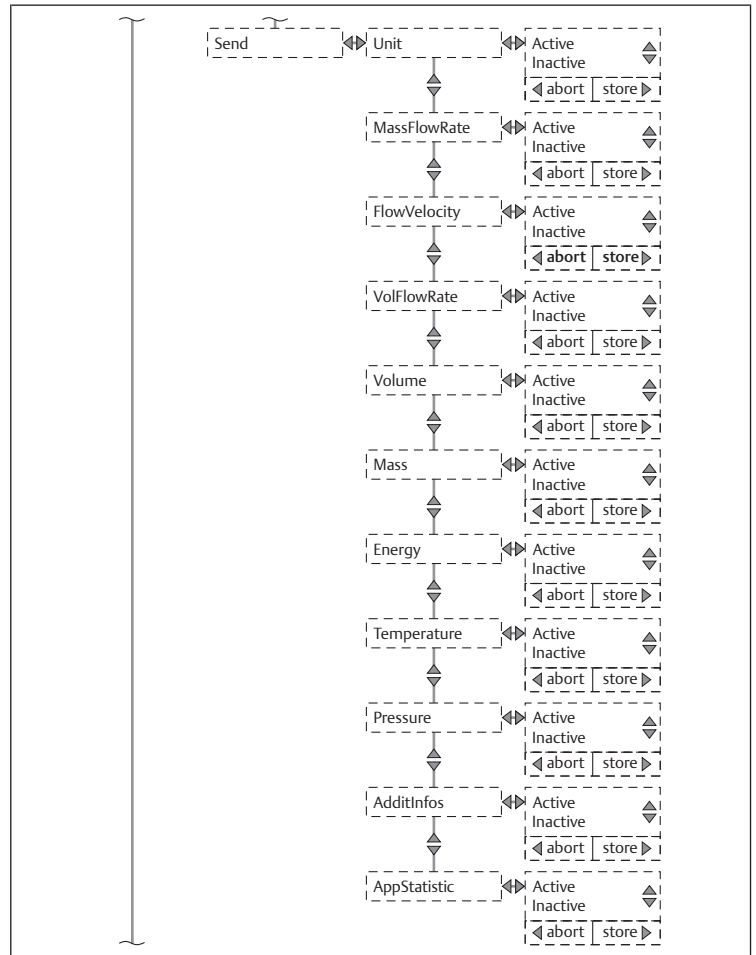
These instructions contain important information for the safe and proper handling of the product.

This documentation is a supplement to the applicable assembly instructions. Read the assembly instructions completely before working with the product.

1.1 Documentation validity

This documentation is intended for:

Programmers, service personnel, system owners

This documentation provides supplementary information for handling the following product variants of series AF2 and 652/653:

Series	Product variant	Interface
AF2	Sensor/filter combination (AS)	IO-Link Ethernet
	High-flow sensor (HF)	IO-Link Ethernet
652	Filter product variant	IO-Link (A) Ethernet (B)
	Pipe product variant	IO-Link (A) Ethernet (B)
653	Filter product variant	IO-Link (A) Ethernet (B)
	Pipe product variant	IO-Link (A) Ethernet (B)

1.2 Additional documentation

Observe the following related documents:

- Manufacturer's system documentation
- Documentation of other system components
- Assembly instructions (R412026496 or 549411)

1.3 Abbreviations used

This documentation uses the following abbreviations:

Abbreviation	Meaning
ABS	Acrylonitrile butadiene styrene
GF	Fiberglass
HF	High flow
MBE	Full scale value
MQTT	Message Queuing Telemetry Transport
MTTF	Mean Time To Failure
NPT	National Taper Pipe
OLED	Organic Light Emitting Diode
OPC UA	Open Platform Communications Unified Architecture
PA	Polyamide
PC	Polycarbonate
PPE	Personal protective equipment
Pt	Platinum measuring resistor

2 Safety

2.1 About this chapter

- Read the chapter Safety of the assembly instructions and this documentation completely before working with the product.
- Keep this documentation in a location where it is accessible to all users at all times.

3 Data and parameters

3.1 Notes on safety

- Do not make parameter changes during operation (injury prevention).

3.2 Parameter data

3.2.1 General settings

The parameter settings in this section apply to all variants of the product.

General

Objective	Menu	Option
Make settings	Standard screen	Press and hold any arrow button for at least 2 seconds and make your settings in the respective menu.

Display

Objective	Submenu	Option
Set the units	Units	Select from the following menus: <ul style="list-style-type: none"> • <i>MassFlowRate</i> • <i>FlowVelocity</i> • <i>Volume</i> • <i>VolFlowRate</i> • <i>Mass</i> • <i>Energy</i> • <i>Temperature</i> • <i>Pressure</i>
Set the display for screen 1.1	Pages	<ul style="list-style-type: none"> • Select <i>Disp1Top</i> • Select <i>Disp1Btm</i>
Set the display for screen 1.2	Pages	<ul style="list-style-type: none"> • Select <i>Disp2Top</i> • Select <i>Disp2Btm</i>
Set the display for screen 1.3	Pages	<ul style="list-style-type: none"> • Select <i>Disp3Top</i> • Select <i>Disp3Btm</i>
Set the display for screen 2.1, 2.2, and 2.3	Pages	Select display parameters in the <i>DispHistory</i> menu
Optimize readability	Rotation	Set the display to 0°, 90°, 180°, or 270°
Activate the screen saver	ScreenSaver	Set the time for screen saver activation
Switch off the display	AutoOff	Set the time for switching off the display
Setting the brightness	Brightness	Setting the brightness in percent
Assign PIN to protect against operation and manipulation	Display Pin	Assign 4-digit PIN

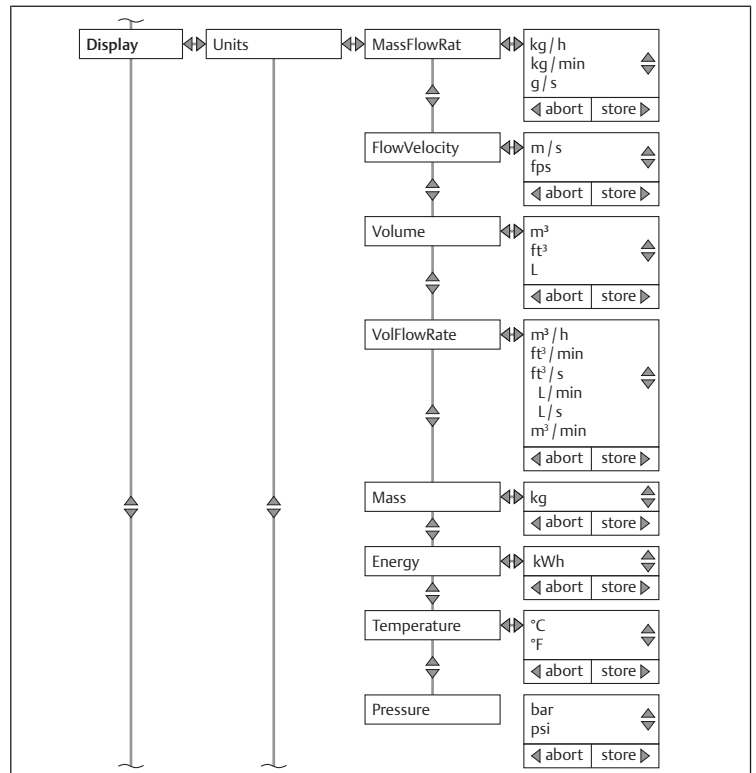

Fig. 1

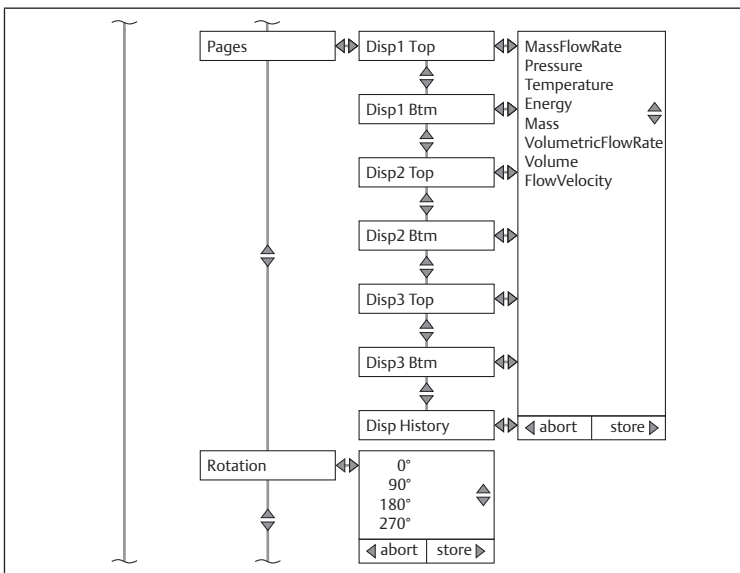

Fig. 2

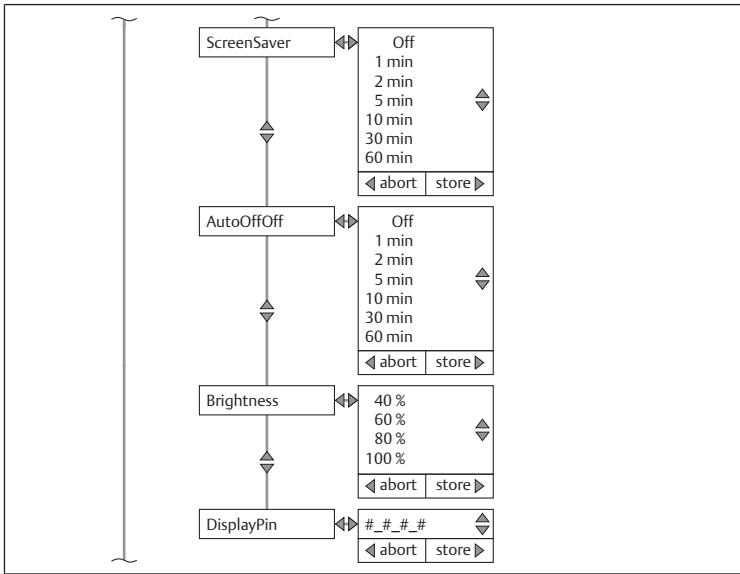

Fig. 3

Simulate

Objective	Submenu	Option
Simulate media flow	Flow	Simulate media flow
Simulate temperature	Temperature	Simulate temperature
Simulate pressure	Pressure	Simulate pressure

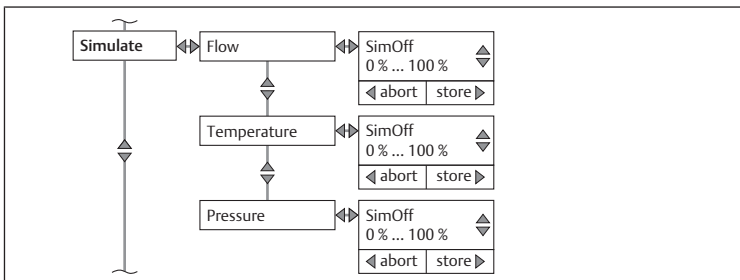

Fig. 4

Measure

Objective	Submenu	Option
Set the measuring medium	Flow	Select the Medium option and set the measuring medium: <ul style="list-style-type: none"> Air Argon CO2 Nitrogen

Objective	Submenu	Option
Set the reference standard	Flow	Select the RefCond option and set the reference standard: <ul style="list-style-type: none"> ISO 2533 ISO 1217 DIN 1945-1 DIN 1343 ISO 6358 ISO 8778 UserDefined (application-specific)
Set the reference pressure for application-specific setting (UserDefined)	Flow	Select the RefCond option and select UserDefined (application-specific reference pressure)
Setting the zero offsets	Flow	Select the 0-FlowOff option and set the zero offsets
Setting the low flow cut-off	Flow	Select the 0-FlowCut option and set the low flow cut-off
Mean value filter for measuring value smoothing in display and output	Flow/Pressure/Temperature	Select the Filter option and set the measured value filter
Setting the offset/zero offsets	Pressure/temperature	Select the Offset option and set the offset/zero offsets
Selecting the signal quality	SigQuality	Select between SigQua1 , SigQua2 , SigQua3 , and SigQua4 . Quality is set to 100 % in each case. Signal quality 1 is a measure of robustness

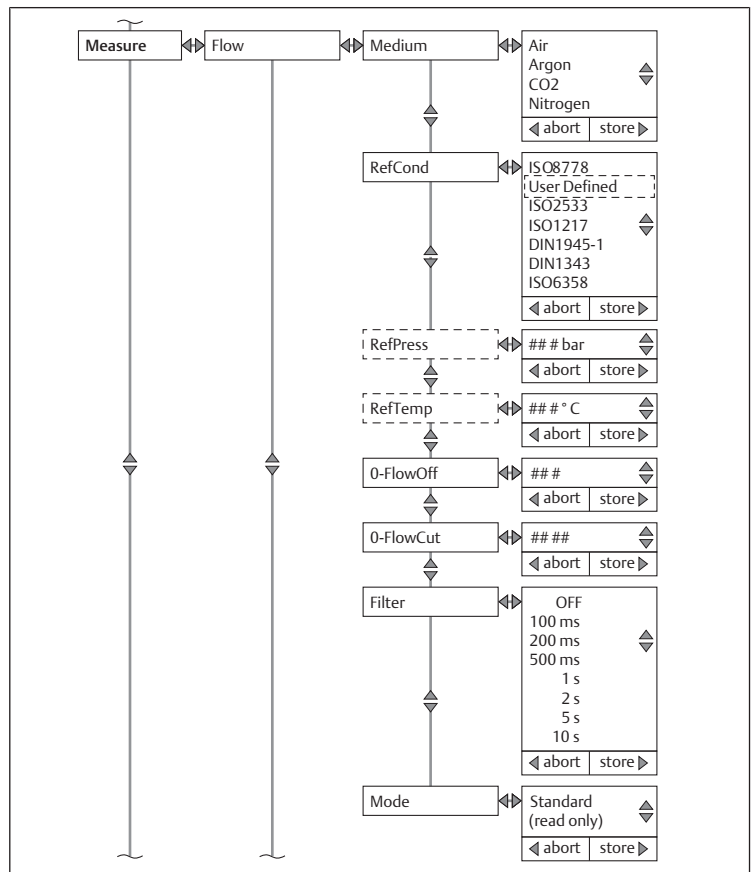

Fig. 5

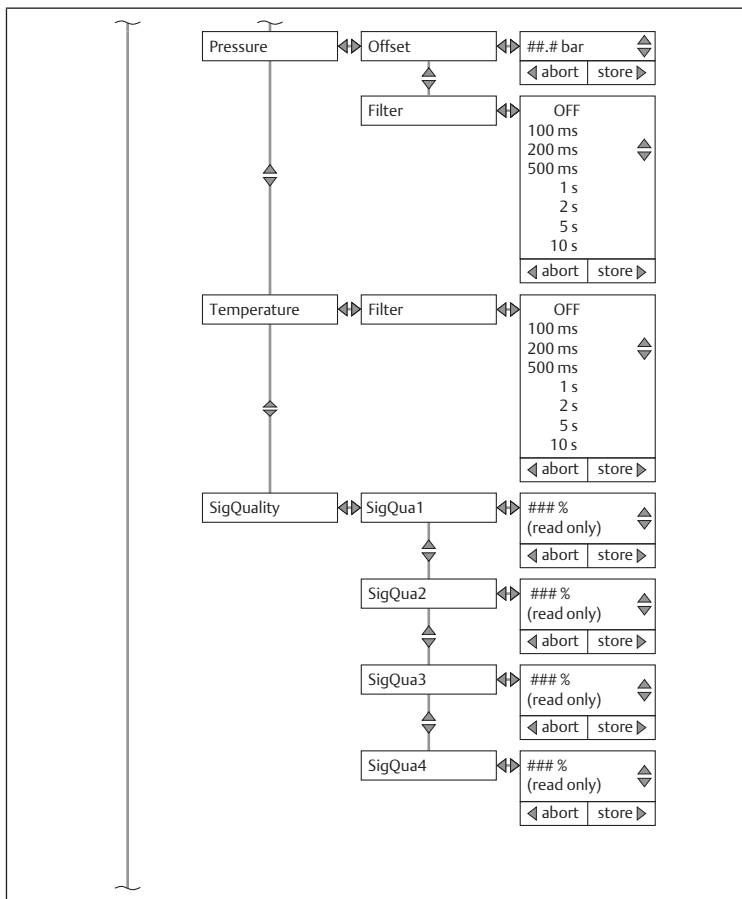

Fig. 6

History

Objective	Submenu	Option
Select the display/graph showing the measured values for the last 60 minutes	60 min	Select the display/graph showing the measured values for the last 60 minutes
Select the display/graph showing the measured values for the last 24 hours	24 hour	Select the display/graph showing the measured values for the last 24 hours
Select the display/graph showing the measured values for the last 7 days	7 days	Select the display/graph showing the measured values for the last 7 days

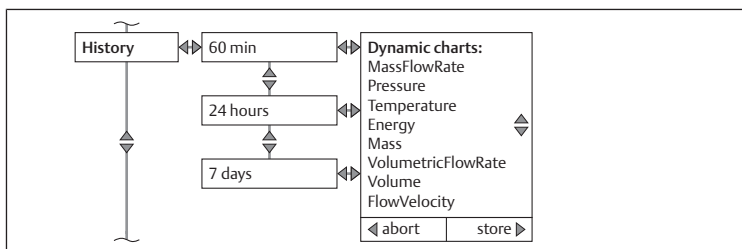

Fig. 7

Statistics

Objective	Submenu	Option
Minimum values, mean values, and maximum values for the individual parameters after the last reset	View	View the <i>Max, mean, min values</i> for the individual parameters after the last reset
View the time of the last reset (read only)	LastReset	View the time of the last reset
Reset the statistics values to 0	Reset	Reset the statistics values to 0

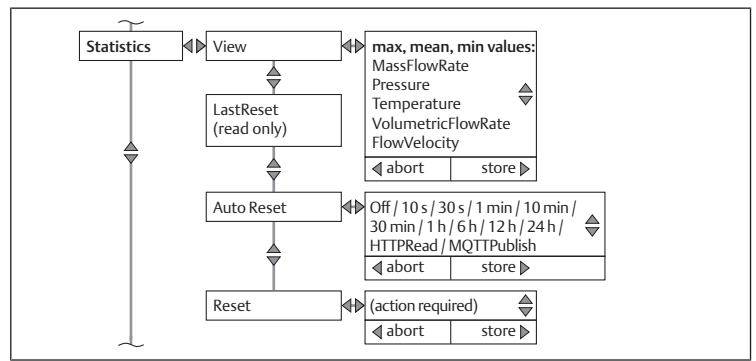

Fig. 8

Counter

Objective	Submenu	Option
View the counter		Select from the <i>Mass, Volume, Energy,</i> and <i>LastReset</i> submenus and view the counter
Reset the counter	Reset	Reset the counter

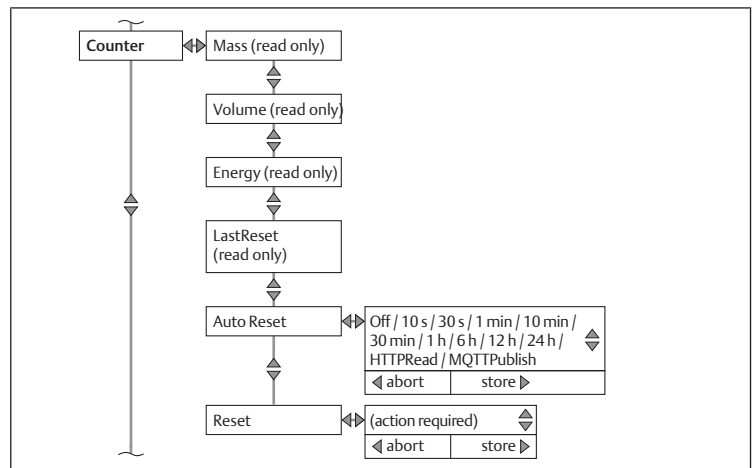

Fig. 9

System

Objective	Submenu	Option
Service login	Service	Perform a service login for authorized users
Reset to factory settings	FactReset	Reset the system to the factory settings
Serial Number (read only)	SerialNumber	View the part number (serial number)
Set the device tag	DevTag	Set the device tag
Set the Application tag	AppTag	Set the Application tag
FWVersion (read only)	FWVersion	View the firmware version
Calibration (read only)	Calibration	View the firmware defaults
BLVersion (read only)	BLVersion	View the bootloader version
HWVersion (read only)	HWVersion	View the hardware version

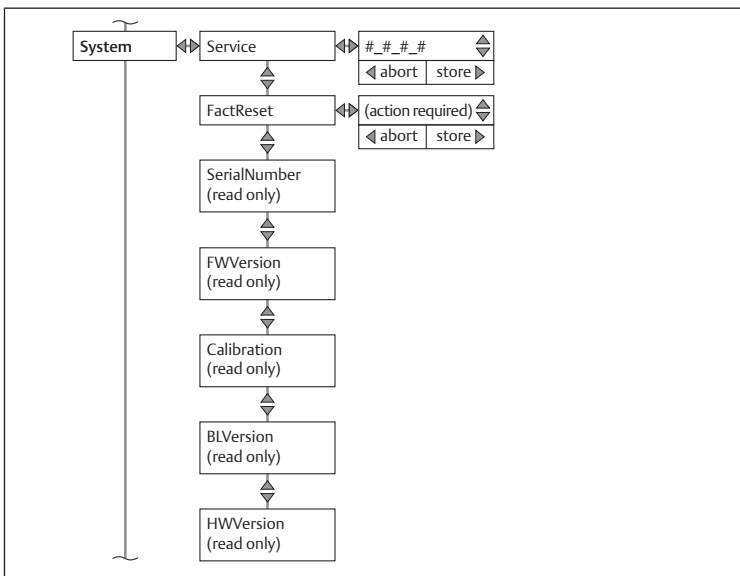

Fig. 10

Tags

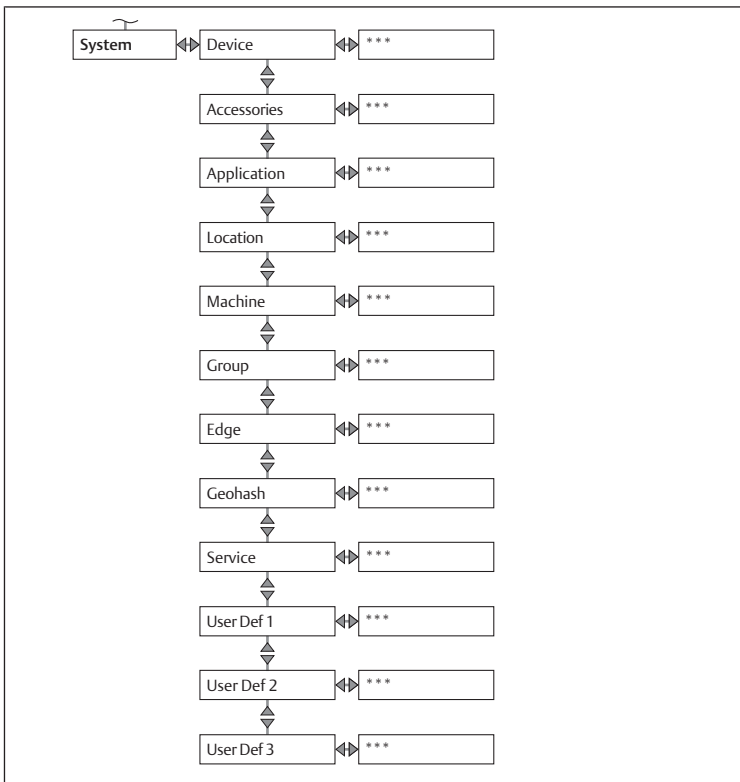

Fig. 11

3.2.2 Settings for the IO-Link variant

The settings apply to all variants of the product with IO-Link electrical connection.

IO-Link

The display shows the measured value menu with the default setting (kg/h, m/s).

Objective	Menu	Option
Select menu	Standard screen	Press and hold any arrow button for at least 2 seconds and select between <i>Q1 Menu</i> , <i>Q2 Menu</i> , and <i>Qa Menu</i> .
Set the switch output	Q1 Menu	Set the switch output
Set the switch output	Q2 Menu	Set the switch output
Set the analog output	Qa Menu	Set the analog output

Q1 Menu

The Q1 menu contains the settings for switch output 1.

Objective	Submenu	Option
Set the hysteresis or window function	Mode	Set the mode for hysteresis or window function with the associated measurement parameters
Set the switching point	SetPoint1	Set the switching point
Set the resetting point/hysteresis or lower window limit	SetPoint2	Set the resetting point/hysteresis or lower window limit
Set the switching characteristics of the break contact	Polarity	Select between <i>Normally-Closed</i> and <i>NormallyOpen</i>
Simulate the switch output	Simulate	Select <i>Active</i> , <i>Inactive</i> , or <i>Normal</i> (measuring operation)
Set PNP/NPN or push/pull (DRV)	DriverType	Set to <i>PNP/NPN</i> or <i>push/pull (DRV)</i>

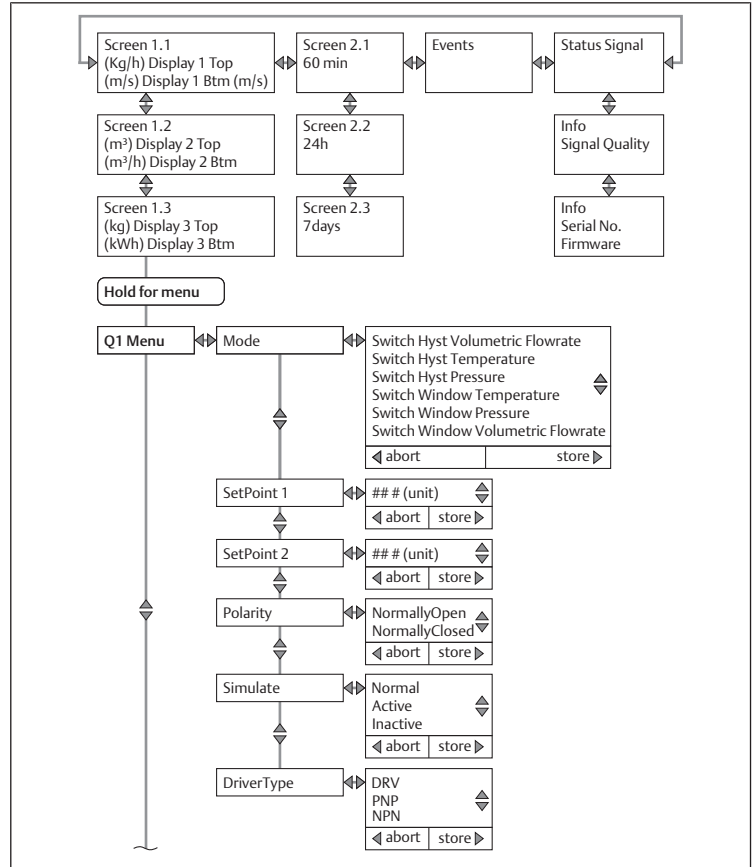

Fig. 12

Q2 Menu

The Q2 menu contains the settings for switch output 2.

Objective	Submenu	Option
Set the switch output as switch output, frequency, pulse, or analog	Function	Set the switch output as <i>Switch</i> , <i>Frequency</i> , <i>Pulse</i> , or <i>Analog</i>
Set the mode for hysteresis or window function	Mode	Set the mode for hysteresis or window function
Set the switching point	SetPoint1	Set the switching point
Set the resetting point/hysteresis or lower window limit	SetPoint2	Set the resetting point/hysteresis or lower window limit
Set the switching characteristics of the break contact	Polarity	Select between <i>Normally-Closed</i> and <i>NormallyOpen</i>
Simulate the switch output	Simulate	Select between <i>Active</i> , <i>Inactive</i> , and <i>Normal</i> (measuring operation)
Set to PNP/NPN or push/pull	DriverType	Set to <i>PNP/NPN</i> or <i>push/pull</i>

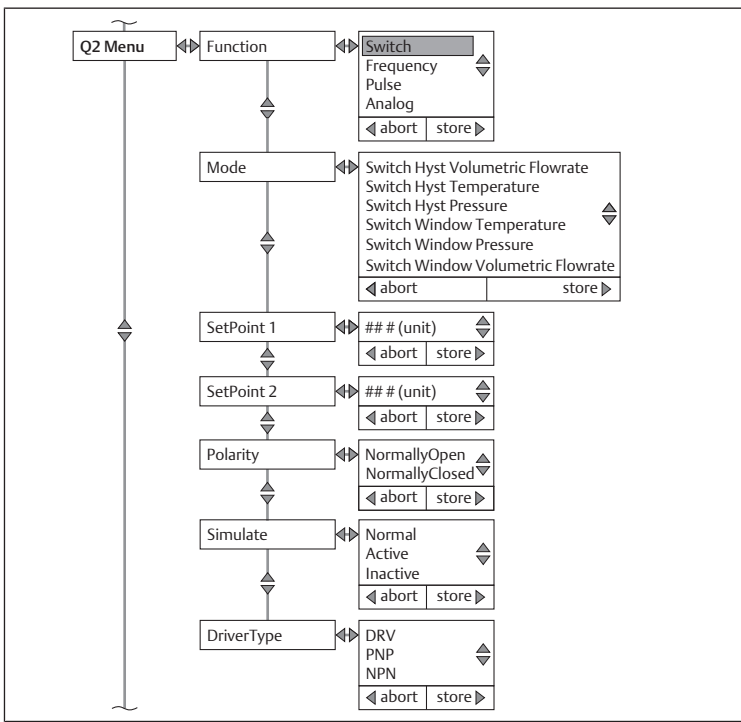

Fig. 13

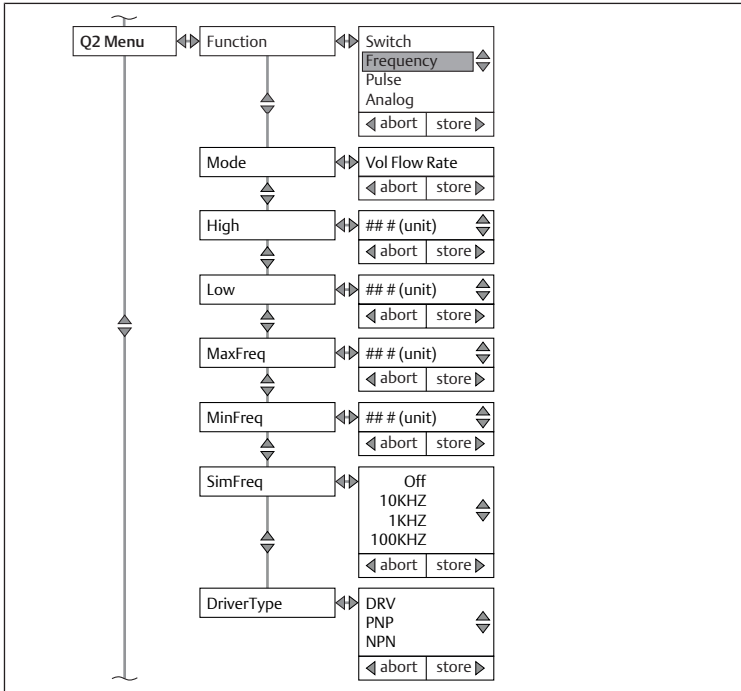

Fig. 14

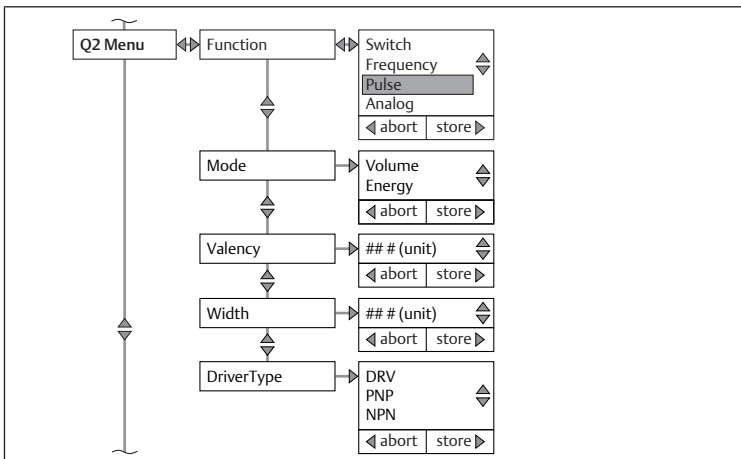

Fig. 15

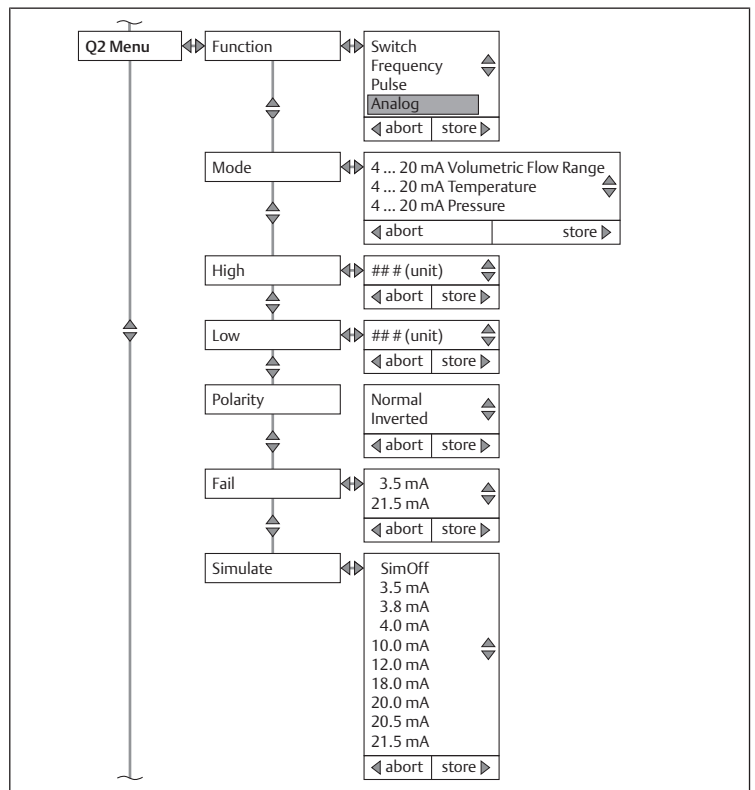

Fig. 16

Qa Menu

The Qa menu contains the settings for the analog output.

Objective	Submenu	Option
Assign measurement parameters to the current output	Mode	Assign measurement parameters such as flow, temperature, or pressure to the current output
Assign the full scale value	High	Set the full scale value to 20 mA
Assign the measurement range start value	Low	Set the measurement range start value to 4 mA
Set the inversion of the current output	Polarity	Set the inversion of the current output
Set the behavior of the current output if a failure occurs on the product	Fail	Set the behavior of the current output if a failure occurs on the product
Set a predefined current value	Simulate	Set a predefined current value

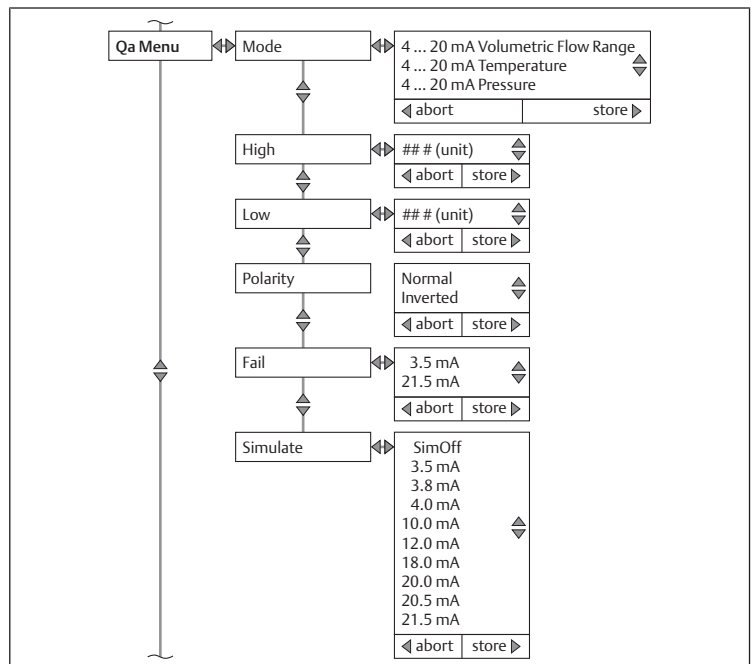

Fig. 17

3.2.3 Settings for the Ethernet variant

The settings apply to all variants of the product with Ethernet electrical connection.

Ethernet

Objective	Submenu	Option
Assign a static or dynamic address	DHCP Mode	Assign an address
Set the IP address	IP Address	Set the IP address
SubNetMask	SubNetMask	Set the subnet mask
Gateway	Gateway	Set the gateway address
Name	Name	Set the DHCP name

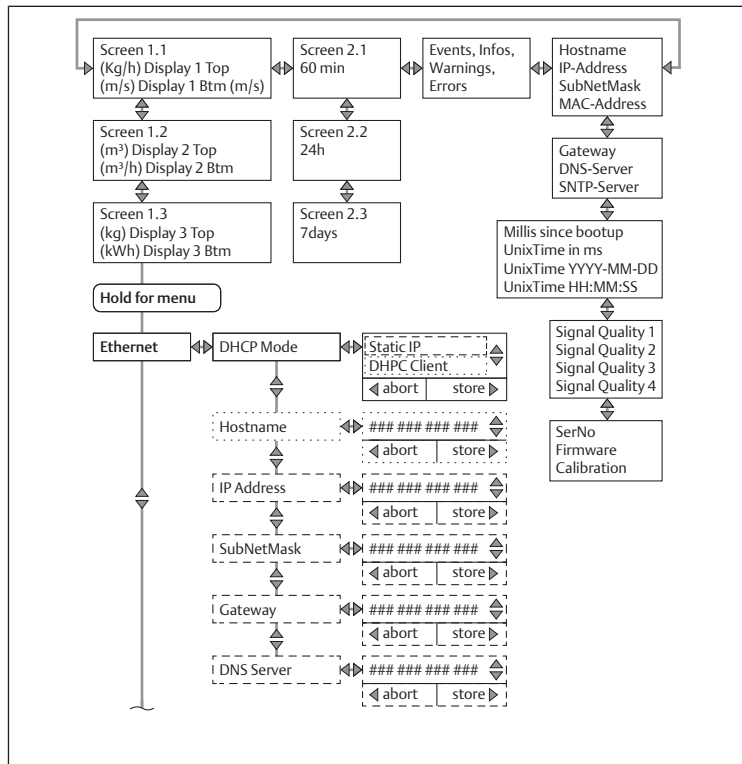
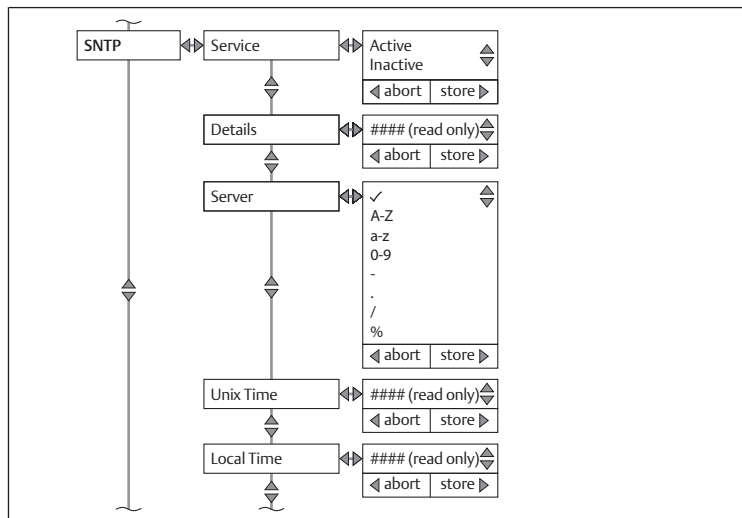

Fig. 18

SNTP



Web server

Objective	Submenu	Option
Switch the web interface on and off	State	Select between Active and In-active
Set the port	Port	Select the web server port. The default port for the HTTP service is port 80

Objective	Submenu	Option
Reset the user-defined password	ResetPW	Reset the web server password for the "Maintenance" user to factory default. The default password (factory setting) is "airflowsensor"

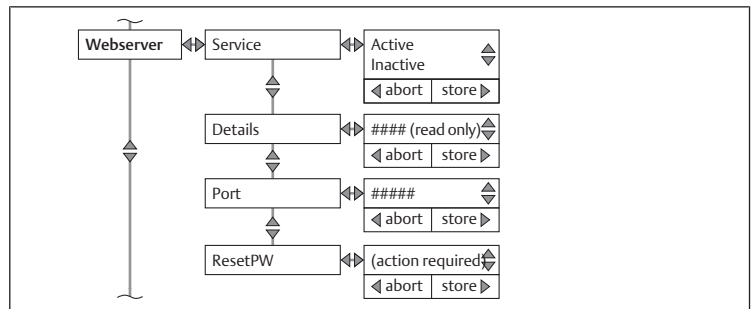

Fig. 19

OPC UA

Objective	Submenu	Option
Switch the web interface on and off	State	Select between Active and In-active
Set the port	Port	Set the port
Set the user name	User	Set the user name
Assign a password	Password	Set the password

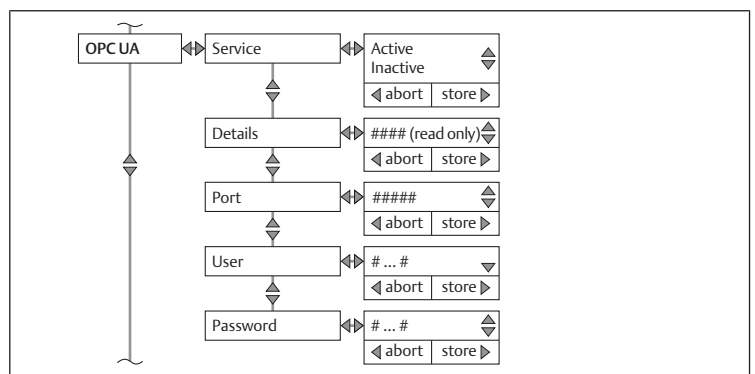

Fig. 20

MQTT

Objective	Submenu	Option
Switch the web interface on and off	State	Select between Active and In-active
Broker	Broker	Set the broker
Set the port	Port	Set the port
Topic	Topic	View the topics
User	User	Enter a user name for the broker
Create the broker password	Password	Enter the broker password
Send the update interval to the broker	Update	Set the update interval
QoS	QoS	Select QoS-0 , QoS-1 , or QoS-2
Define MQTT message to the broker	Send	Select a menu item from the second submenu and set to Active or In-active

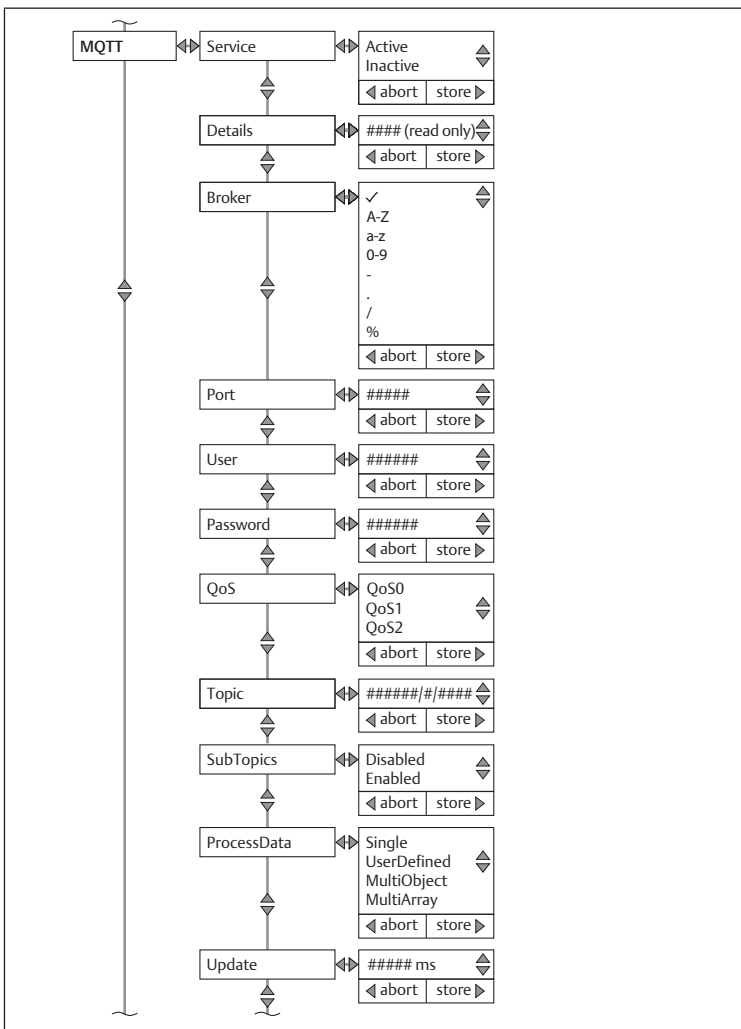

Fig. 21

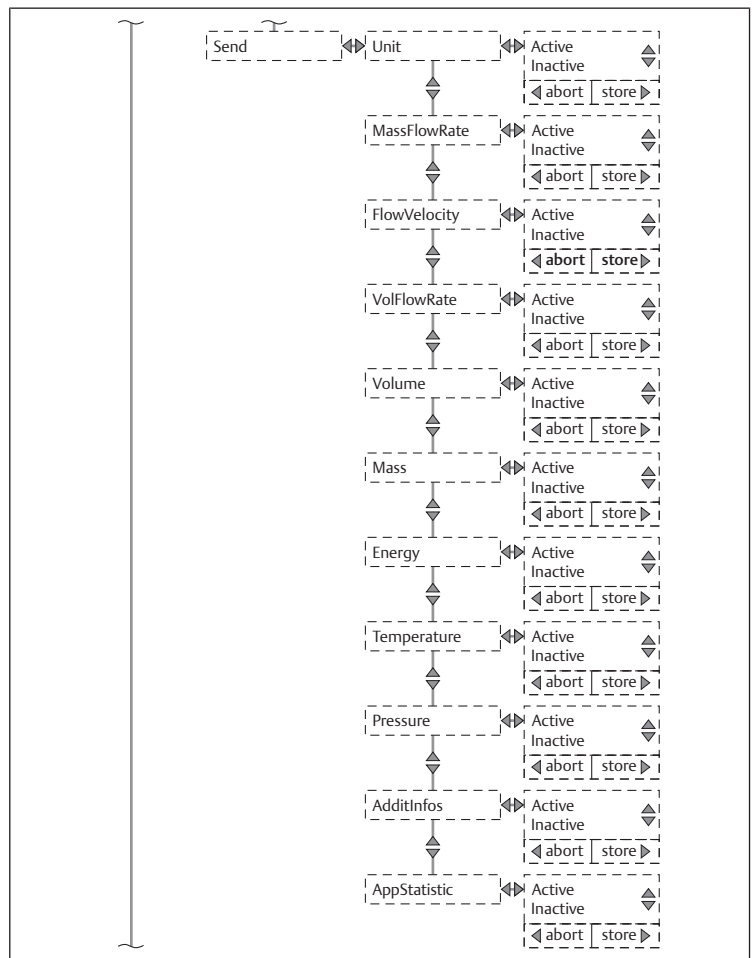

Fig. 22

Table des matières

1	A propos de cette documentation	19
1.1	Validité de la documentation	19
1.2	Documentation supplémentaire	19
1.3	Abréviations utilisées	19
2	Sécurité	19
2.1	À propos de ce chapitre	19
3	Données et paramètres	19
3.1	Consignes relatives à la sécurité	19
3.2	Données de paramètres	19
3.2.1	Réglages généraux	19
3.2.2	Réglages pour la variante Ethernet IO-Link	22
3.2.3	Réglages pour la variante Ethernet	24

1 A propos de cette documentation

Les présentes instructions contiennent d'importantes informations pour une utilisation du produit en toute sécurité et conformité.

Cette documentation complète les instructions de montage également applicables. Lire intégralement les instructions de montage avant de travailler avec le produit.

1.1 Validité de la documentation

Cette documentation s'adresse à :

Programmateurs, personnel de service, exploitants d'installation

Cette documentation fournit des informations complémentaires pour le manie- ment des variantes de produit suivantes de la série AF2 et 652/653 :

Série	Variante de produit	Interface
AF2	Combinaison filtre/capteur (AS)	IO-Link Ethernet
	Capteur High Flow (HF)	IO-Link Ethernet
652	Variante de produit avec filtre	IO-Link (A) Ethernet (B)
	Variante de produit avec tuyau	IO-Link (A) Ethernet (B)
653	Variante de produit avec filtre	IO-Link (A) Ethernet (B)
	Variante de produit avec tuyau	IO-Link (A) Ethernet (B)

1.2 Documentation supplémentaire

Tenez compte de la documentation de référence obligatoire suivante :

- Documentation d'installation du fabricant
- Documentation des autres composants de l'installation
- Instructions de montage (R41 2026496 ou 549411)

1.3 Abréviations utilisées

Les abréviations suivantes sont utilisées dans cette documentation :

Abréviation	Signification
ABS	Acrylonitrile butadiène styrène
GF	Fibre de verre
HF	High Flow
MBE	Valeur finale de la plage de mesure
MQTT	Message Queuing Telemetry Transport
MTTF	Mean Time To Failure (durée moyenne de service jusqu'à la panne)
NPT	National Taper Pipe (type de filetage de tube)
OLED	Organic Light Emitting Diode (diode luminescente organique)
OPC UA	Open Platform Communications Unified Architecture
PA	Polyamide
PC	Polycarbonate
EPI	Equipement de protection individuel
Pt	Résistance de mesure en platine

2 Sécurité

2.1 À propos de ce chapitre

- Lire attentivement et intégralement le chapitre Sécurité des instructions de montage ainsi que toute la documentation avant de travailler avec le produit.
- Conserver la documentation de manière à ce qu'elle soit toujours accessible à tous les utilisateurs.

3 Données et paramètres

3.1 Consignes relatives à la sécurité

- Ne procéder à aucune modification des paramètres en cours de fonctionne- ment (prévention des blessures).

3.2 Données de paramètres

3.2.1 Réglages généraux

Le réglage des paramètres dans cette section s'applique à toutes les variantes du produit.

Généralités

Objectif	Menu	Option
Procéder aux réglages	Affichage par défaut	Pour effectuer des réglages dans le menu correspondant, appuyer sur n'importe quelle touche fléchée pendant au moins 2 secondes.

Display

Objectif	Sous-menu	Option
Réglage des unités	Unités	Sélectionner l'un des menus sui- vants : <ul style="list-style-type: none">• <i>MassFlowRate</i>• <i>FlowVelocity</i>• <i>Volume</i>• <i>VolFlowRate</i>• <i>Mass</i>• <i>Energy</i>• <i>Temperature</i>• <i>Pressure</i>
Régler l'afficheur 1.1	Pages	<ul style="list-style-type: none">• Sélectionner <i>Disp1Top</i>• Sélectionner <i>Disp1Btm</i>
Régler l'afficheur 1.2	Pages	<ul style="list-style-type: none">• Sélectionner <i>Disp2Top</i>• Sélectionner <i>Disp2Btm</i>
Régler l'afficheur 1.3	Pages	<ul style="list-style-type: none">• Sélectionner <i>Disp3Top</i>• Sélectionner <i>Disp3Btm</i>
Régler l'afficheur 2.1, 2.2 et 2.3	Pages	Dans le menu <i>DispHistory</i> , sélection- ner les paramètres de l'afficheur
Optimiser la lisibilité	Rotation	Régler l'afficheur sur <i>0°</i> , <i>90°</i> , <i>180°</i> ou <i>270°</i>
Activation du protecteur d'écran	ScreenSaver	Régler le délai d'activation du pro- tecteur d'écran
Désactivation de l'affichage	AutoOff	Régler le délai de désactivation de l'affichage
Régler la luminosité	Brightness	Régler la luminosité en pourcentage
Attribuer un code PIN pour la protection de commande ou la protection contre les manipula- tions	Display Pin	Affecter un code PIN à 4 chiffres

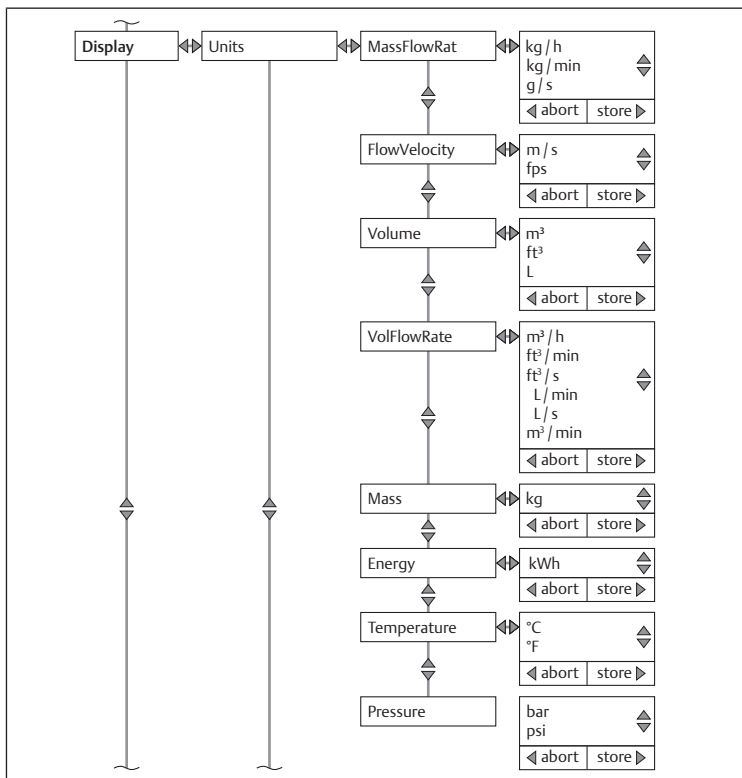

Fig. 1

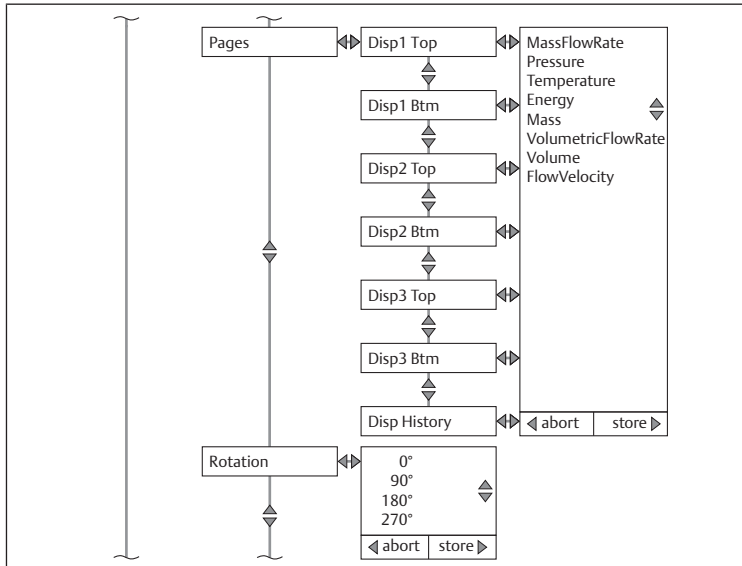

Fig. 2

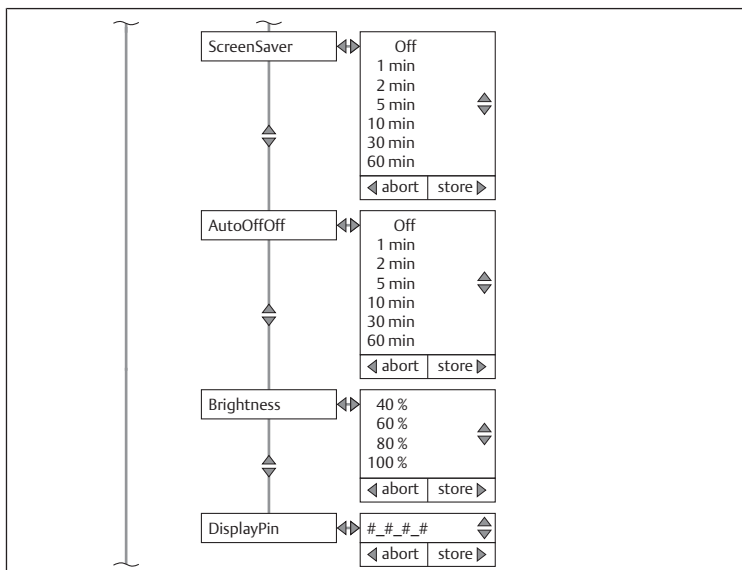

Fig. 3

Simulate

Objectif	Sous-menu	Option
Simuler le débit	Flow	Simuler le débit
Simuler la température	Temperature	Simuler la température
Simuler la pression	Pressure	Simuler la pression

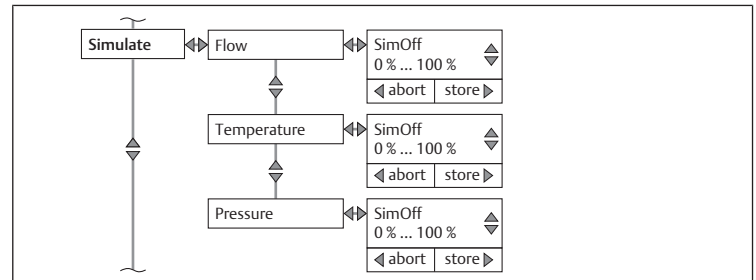

Fig. 4

Mesure

Objectif	Sous-menu	Option
Régler le fluide de mesure	Flow	Sélectionner l'option Medium et régler le fluide de mesure : <ul style="list-style-type: none"> Air Argon CO2 Nitrogen

Régler la norme de référence/ le standard de référence

Sélectionner l'option **RefCond** et régler la norme de référence/le standard de référence :

- ISO 2533
- ISO 1217
- DIN 1945-1
- DIN 1343
- ISO 6358
- ISO 8778
- UserDefined (spécifique à l'application)

Régler la pression de référence spécifique à l'application (UserDefined)

Sélectionner l'option **RefCond** et sélectionner UserDefined (pression de référence spécifique à l'application)

Régler le décalage du point zéro

Sélectionner l'option **0-Flow-Off** et régler le décalage du point zéro

Régler la suppression du débit de fuite

Sélectionner l'option **0-Flow-Cut** et régler la suppression du débit de fuite

Filtre de valeur moyenne pour l'ajustement de la valeur mesurée sur l'afficheur et la sortie

Sélectionner l'option **Filter** et régler le filtre de valeur mesurée

Régler l'offset/le décalage du point zéro

Sélectionner l'option **Offset** et régler l'offset/le décalage du point zéro

Sélectionner la qualité du signal

Sélectionner **SigQua1**, **SigQua2**, **SigQua3** ou **SigQua4**. La qualité est réglée à 100% dans chaque cas. La qualité du signal 1 est un signe de robustesse

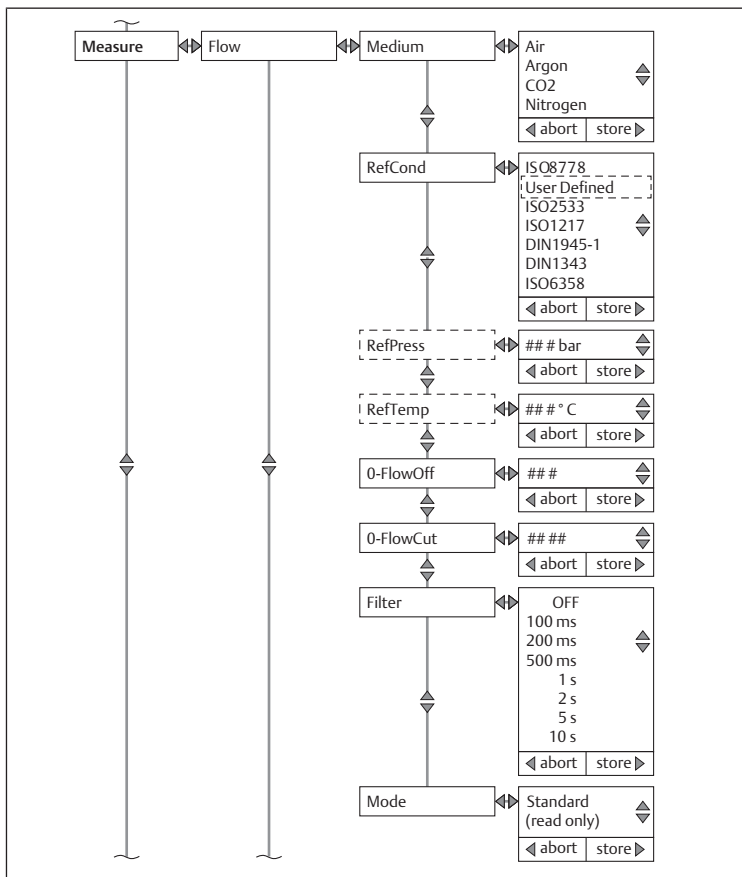

Fig. 5

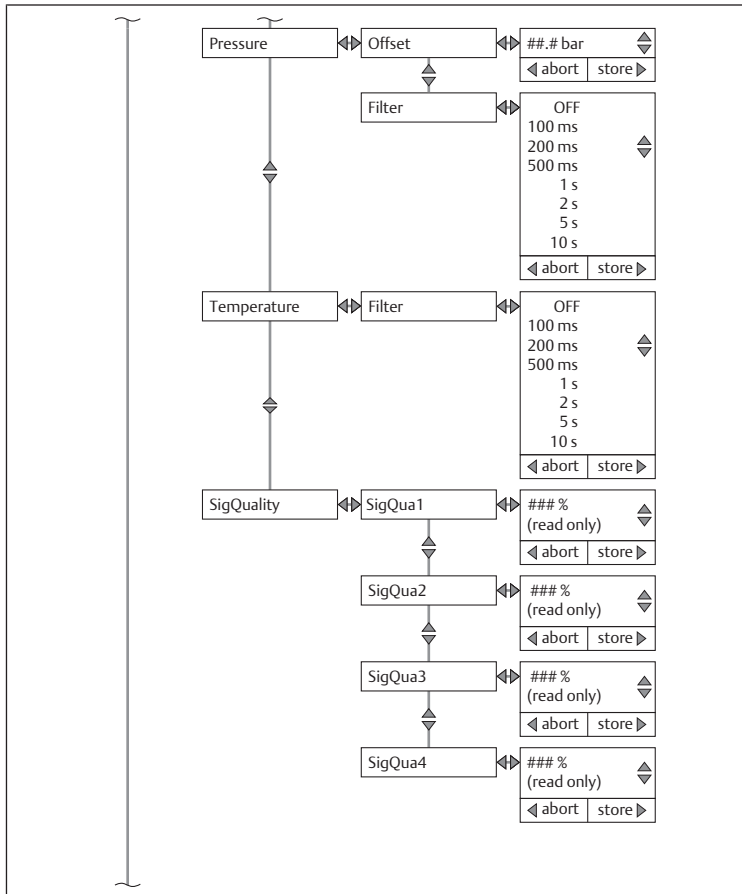

Fig. 6

History

Objectif	Sous-menu	Option
Sélectionner l'affichage/le graphique des valeurs mesurées des dernières 60 minutes	60 min	Sélectionner l'affichage/le graphique des valeurs mesurées des dernières 60 minutes

Objectif	Sous-menu	Option
Sélectionner l'affichage/le graphique des valeurs mesurées des dernières 24 heures	24 hour	Sélectionner l'affichage/le graphique des valeurs mesurées des dernières 24 heures
Sélectionner l'affichage/le graphique des valeurs mesurées des derniers 7 jours	7 days	Sélectionner l'affichage/le graphique des valeurs mesurées des derniers 7 jours

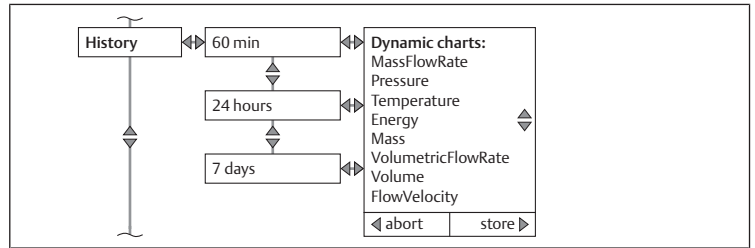

Fig. 7

Statistics

Objectif	Sous-menu	Option
Valeurs minimales, moyennes et maximales de chaque paramètre après la dernière réinitialisation	View	Afficher <i>Max, mean, min values</i> de chaque paramètre après la dernière réinitialisation
Afficher l'heure de la dernière réinitialisation (read only)	LastReset	Afficher l'heure de la dernière réinitialisation
Réinitialiser les valeurs statistiques à 0	Reset	Réinitialiser les valeurs statistiques à 0

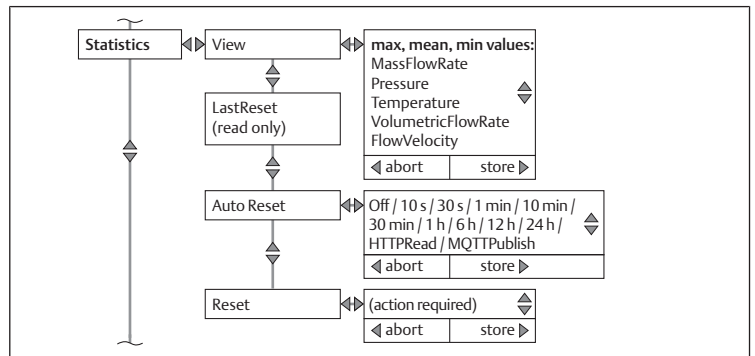

Fig. 8

Counter

Objectif	Sous-menu	Option
Afficher le compteur		Sélectionner les sous-menus <i>Mass, Volume, Energy</i> ou <i>LastReset</i> et afficher le compteur
Réinitialiser le compteur	Reset	Réinitialiser le compteur

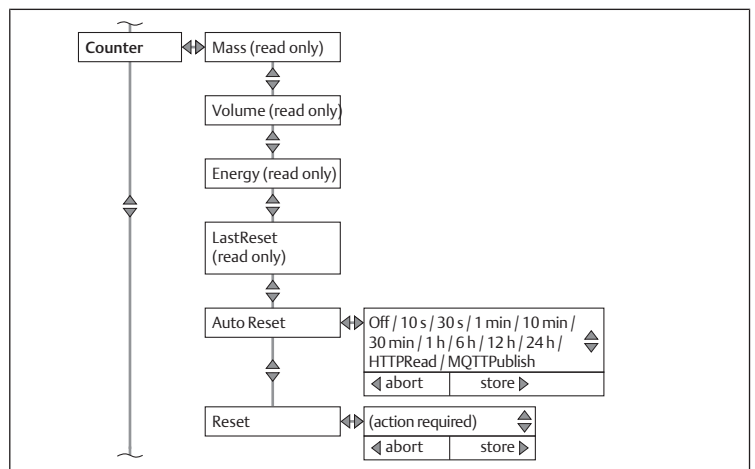

Fig. 9

System

Objectif	Sous-menu	Option
Identifiant de service	Service	Procéder à l'attribution d'un identifiant de service pour un utilisateur autorisé
Réinitialiser aux valeurs d'usine	FactReset	Réinitialiser le système aux valeurs d'usine
Serial Number (read only)	SerialNumber	Afficher le numéro de série
Régler Device-Tag	DevTag	Régler Device-Tag
Régler Application-Tag	AppTag	Régler Application-Tag
FWVersion (read only)	FWVersion	Afficher la version du logiciel
Calibration (read only)	Calibration	Afficher les défauts du logiciel
BLVersion (read only)	BLVersion	Afficher la version du bootload
HWVersion (read only)	HWVersion	Afficher la version de matériel

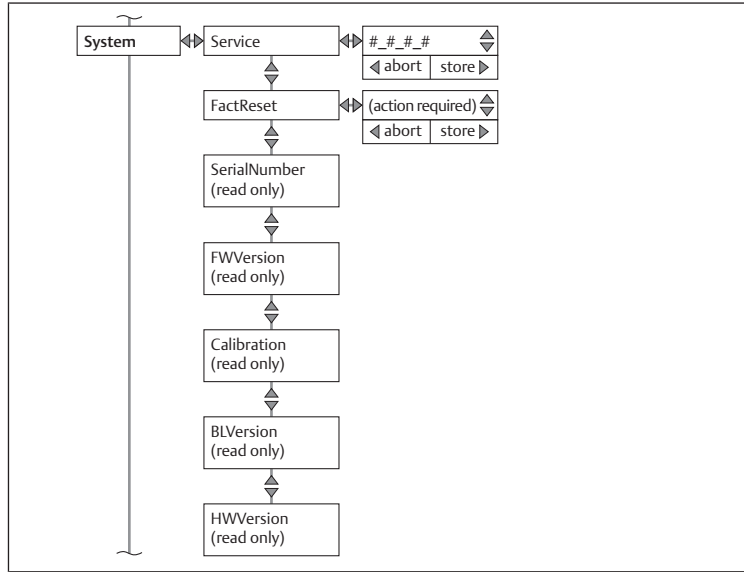

Fig. 10

Tags

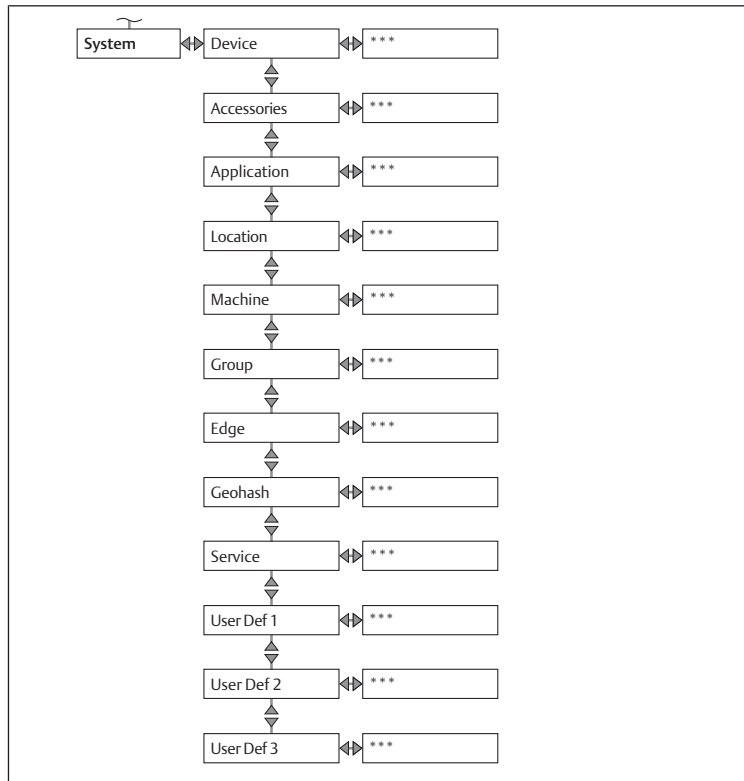

Fig. 11

3.2.2 Réglages pour la variante Ethernet IO-Link

Les réglages s'appliquent à toutes les variantes du produit avec le raccord électrique IO-Link.

IO-Link

L'affichage montre le menu de valeurs mesurées avec le réglage par défaut (kg/h, m/s).

Objectif	Menu	Option
Sélectionner le menu	Affichage par défaut	Appuyer sur n'importe quelle touche fléchée pendant au moins 2 secondes et sélectionner Q1 Menu , Q2 Menu ou Qa Menu .
Régler la sortie de commutation	Q1 Menu	Régler la sortie de commutation
Régler la sortie de commutation	Q2 Menu	Régler la sortie de commutation
Régler la sortie analogique	Qa Menu	Régler la sortie analogique

Q1 Menu

Le menu Q1 contient les réglages de la sortie de commutation 1.

Objectif	Sous-menu	Option
Régler de l'hystérèse ou de la fonction de fenêtre	Mode	Procéder au réglage du mode pour l'hystérèse ou la fonction de fenêtre avec les paramètres de mesure correspondants
Régler le point de commutation	SetPoint1	Régler le point de commutation
Régler le point de commutation vers un niveau inférieur/hystérèse ou la limite inférieure de fenêtre	SetPoint2	Régler le point de commutation vers un niveau inférieur/hystérèse ou la limite inférieure de fenêtre
Régler le comportement de commutation du contact de travail	Polarity	Sélectionner NormallyClosed ou NormallyOpen
Simuler la sortie de commutation	Simulate	Sélectionner Active , Inactive ou Normal (mode de mesure)
Régler PNP/NPN ou Push/Pull (DRV)	DriverType	Régler PNP/NPN ou Push/Pull (DRV)

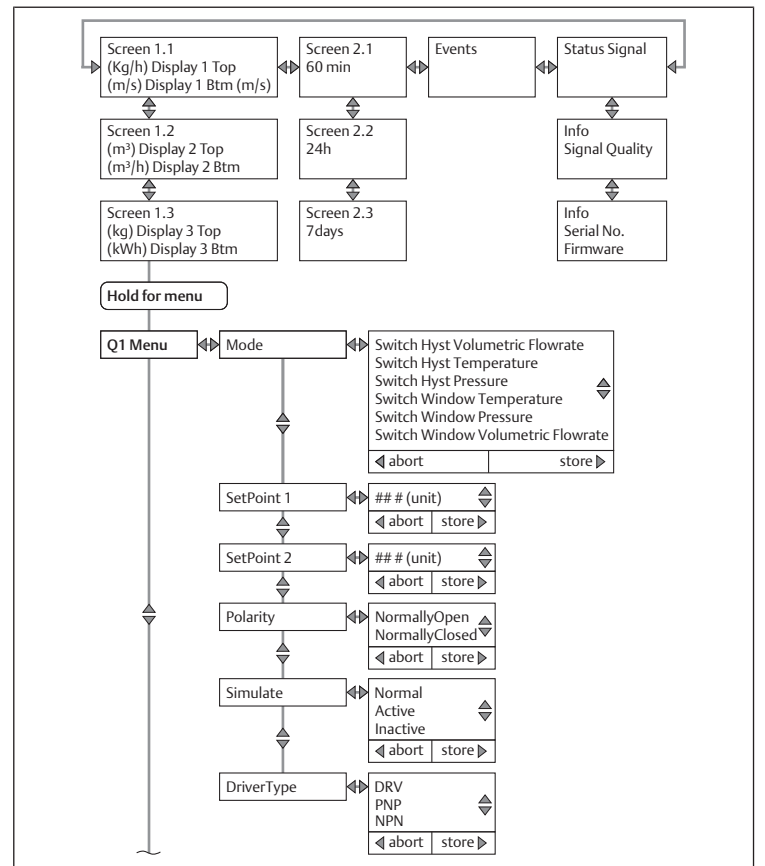

Fig. 12

Q2 Menu

Le menu Q2 contient les réglages de la sortie de commutation 2.

Objectif	Sous-menu	Option
Régler la sortie de commutation comme sortie de commutation, fréquence, impulsion ou analogique	Function	Régler la sortie de commutation comme <i>Switch</i> , <i>Frequency</i> , <i>Pulse</i> ou <i>Analog</i>
Régler mode pour hystérèse ou fonction de fenêtre	Mode	Régler mode pour hystérèse ou fonction de fenêtre
Régler le point de commutation	SetPoint1	Régler le point de commutation
Régler le point de commutation vers un niveau inférieur/hystérèse ou la limite inférieure de fenêtre	SetPoint2	Régler le point de commutation vers un niveau inférieur/hystérèse ou la limite inférieure de fenêtre
Régler le comportement de commutation du contact de travail	Polarity	Sélectionner <i>NormallyClosed</i> ou <i>NormallyOpen</i>
Simuler la sortie de commutation	Simulate	Sélectionner <i>Active</i> , <i>Inactive</i> ou <i>Normal</i> (mode de mesure)
Régler PNP/NPN ou Push/Pull	DriverType	Régler <i>PNP/NPN</i> ou <i>Push/Pull</i>

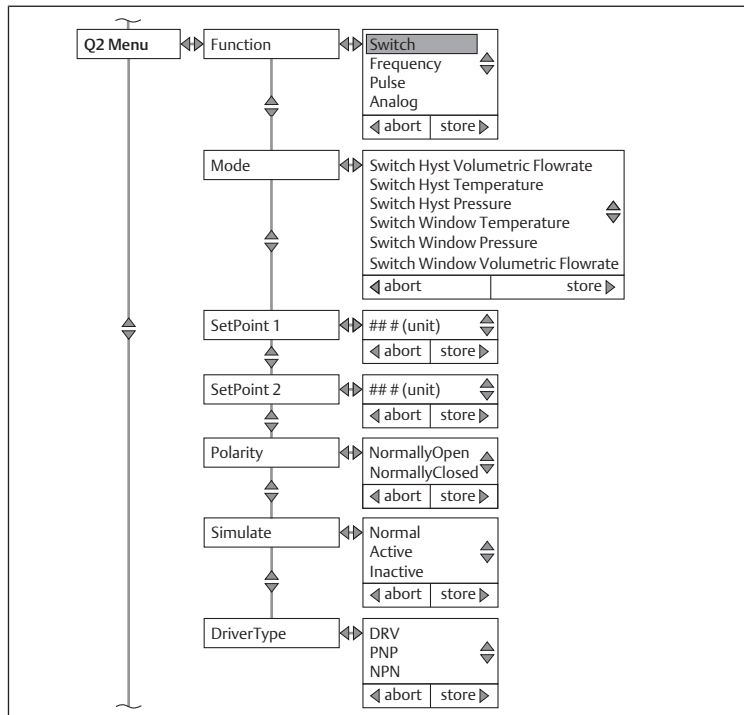

Fig. 13

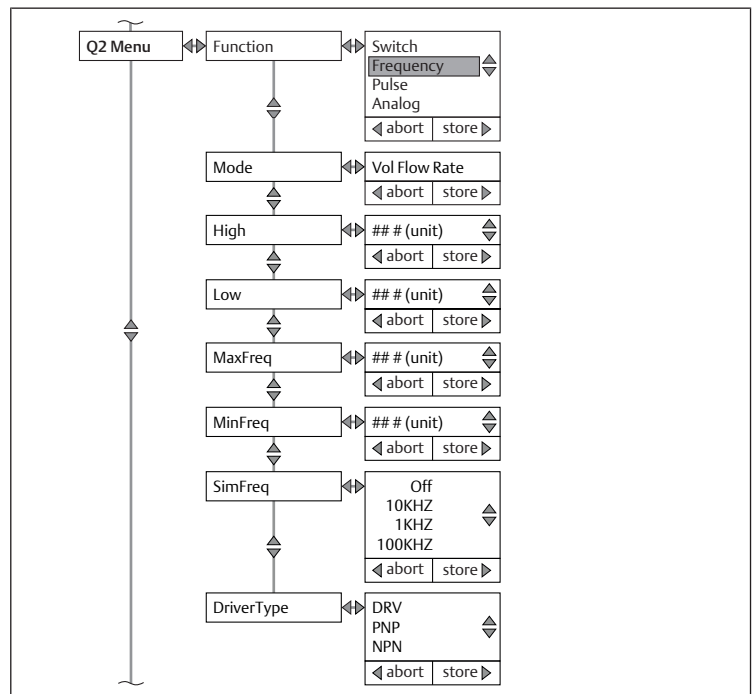

Fig. 14

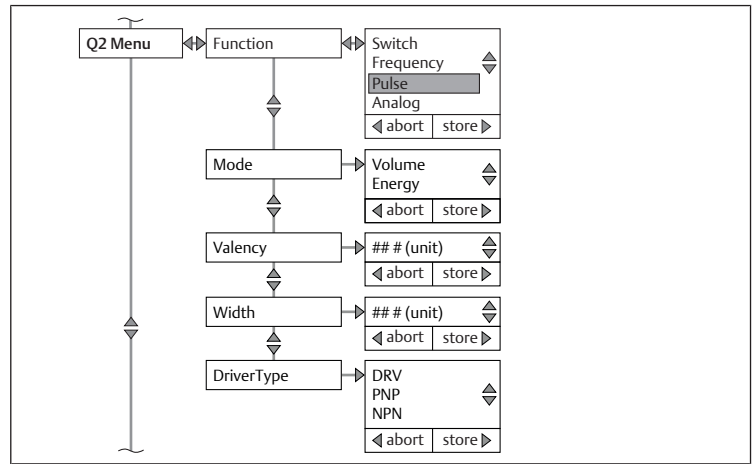

Fig. 15

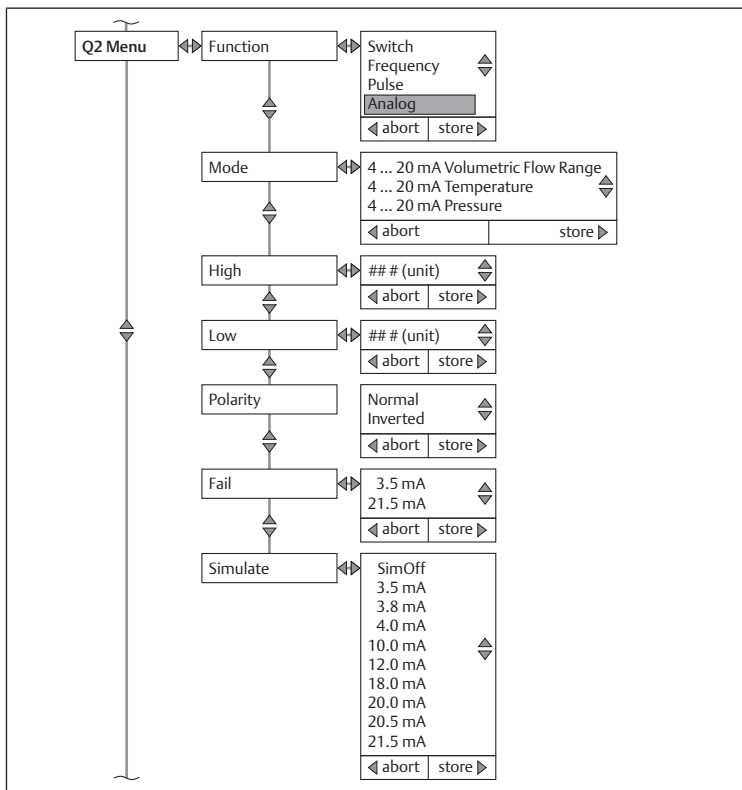

Fig. 16

Qa Menu

Le menu Qa contient les réglages de la sortie analogique.

Objectif	Sous-menu	Option
Affecter les paramètres de mesure à la sortie de courant	Mode	Affecter les paramètres de mesure tels que débit, température ou pression à la sortie de courant
Affecter la valeur finale de la plage de mesure	High	Régler la valeur finale de la plage de mesure sur 20 mA
Affecter le début de la plage de mesure	Low	Régler le début de la plage de mesure sur 4 mA
Régler l'inversion de la sortie de courant	Polarity	Régler l'inversion de la sortie de courant
Régler le comportement de la sortie de courant en cas d'anomalie du produit	Fail	Régler le comportement de la sortie de courant en cas d'anomalie du produit
Régler la valeur de courant prédéfinie	Simulate	Régler la valeur de courant prédéfinie

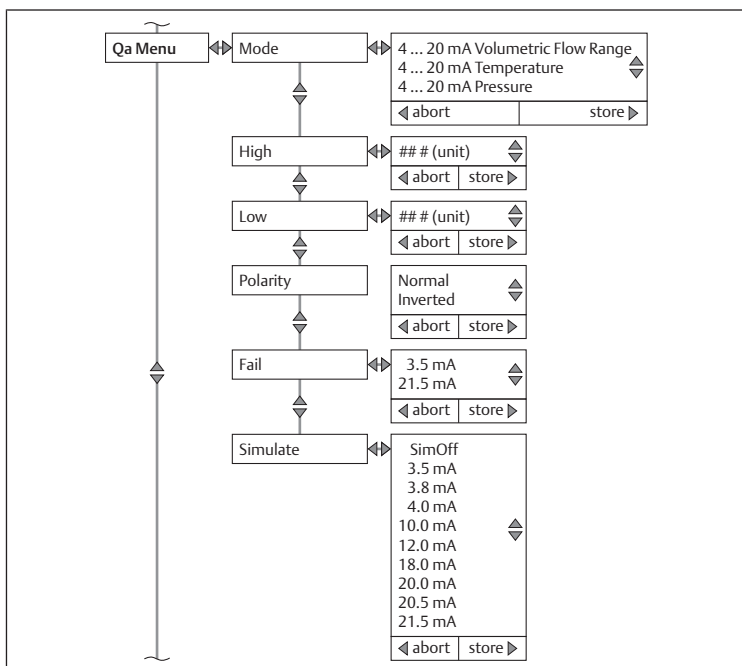

Fig. 17

3.2.3 Réglages pour la variante Ethernet

Les réglages s'appliquent à toutes les variantes du produit avec le raccord électrique Ethernet.

Ethernet

Objectif	Sous-menu	Option
Affecter une adresse statique ou dynamique	DHCP Mode	Affecter une adresse
Régler l'adresse IP	IP Address	Régler l'adresse IP
	SubNetMask	Régler SubNetMask
	Gateway	Régler l'adresse de passerelle
	Nom	Régler le nom DHCP

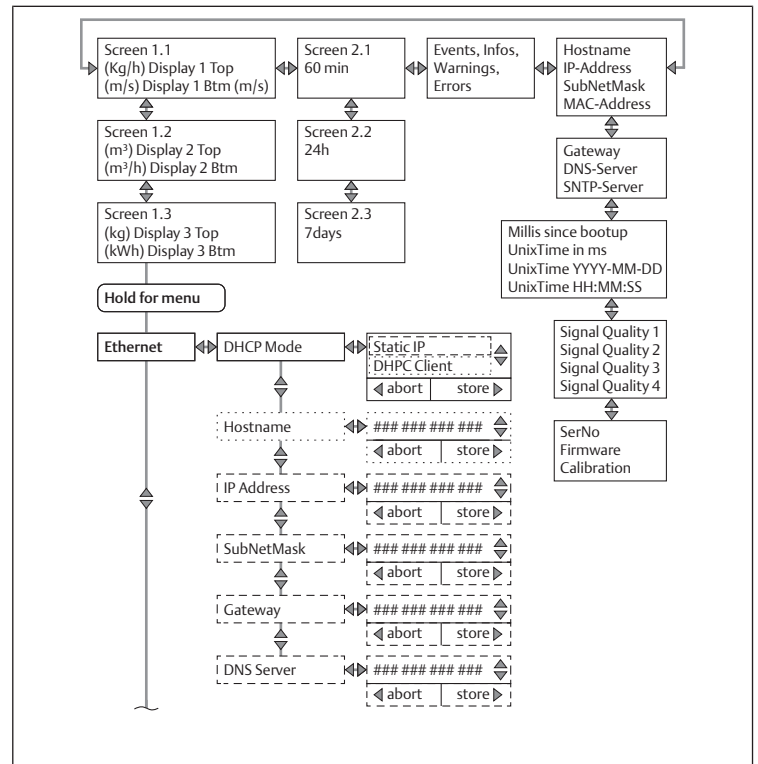
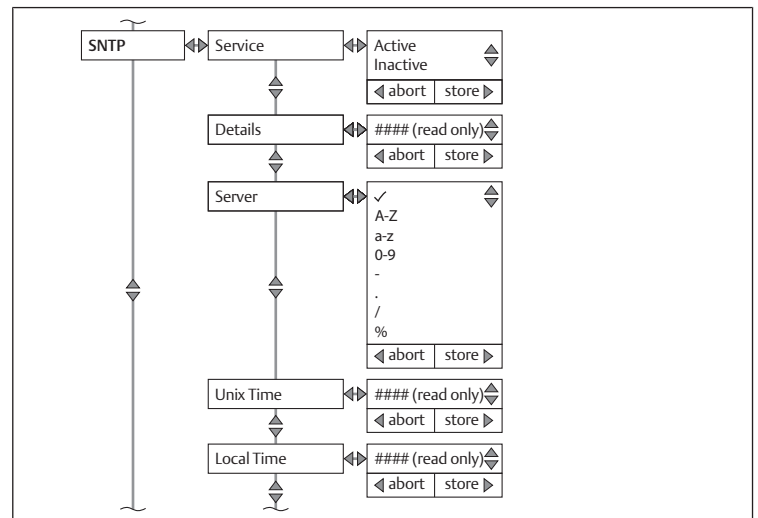

Fig. 18

SNTP



Webserver

Objectif	Sous-menu	Option
Activer/désactiver l'interface web	State	Sélectionner Active ou Inactive
Régler le port	Port	Sélectionner le port du serveur web. Le port par défaut pour le service HTTP est le port 80

Objectif	Sous-menu	Option
Réinitialiser le mot de passe côté utilisateur	ResetPW	Réinitialiser le mot de passe du serveur web pour l'utilisateur « Maintenance » à l'état de livraison. Le mot de passe par défaut (réglage d'usine) est « airflowsensor »

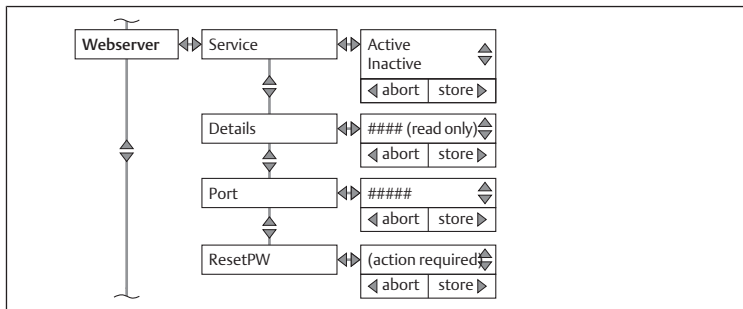

Fig. 19

OPC UA

Objectif	Sous-menu	Option
Activer et désactiver l'interface web	State	Sélectionner <i>Active</i> ou <i>Inactive</i>
Régler le port	Port	Régler le port
Régler le nom de l'utilisateur	User	Régler le nom de l'utilisateur
Attribuer un mot de passe	Password	Régler le mot de passe

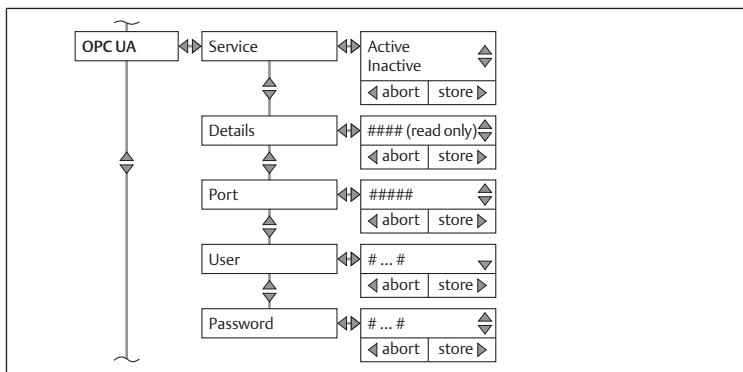

Fig. 20

MQTT

Objectif	Sous-menu	Option
Activer et désactiver l'interface web	State	Sélectionner <i>Active</i> ou <i>Inactive</i>
Broker	Broker	Régler le gestionnaire
Régler le port	Port	Régler le port
Topic	Topic	Afficher les sujets
User	User	Attribuer nom d'utilisateur pour gestionnaire
Créer un mot de passe de gestionnaire	Password	Saisir mot de passe de gestionnaire
Envoyer l'intervalle de coupe au gestionnaire	Update	Déterminer l'intervalle de coupe
QoS	QoS	Sélectionner <i>QoS-0</i> , <i>QoS-1</i> ou <i>QoS-2</i>
Définir message MQTT au gestionnaire	Send	Sélectionner le point de menu et régler <i>Active</i> ou <i>Inactive</i>

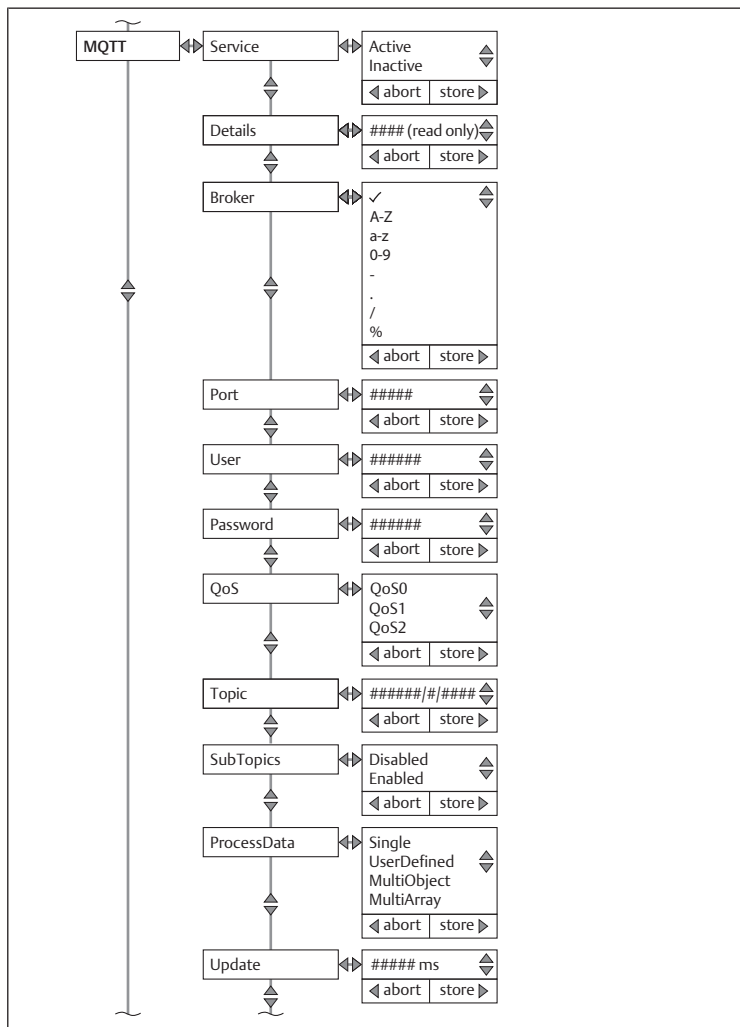

Fig. 21

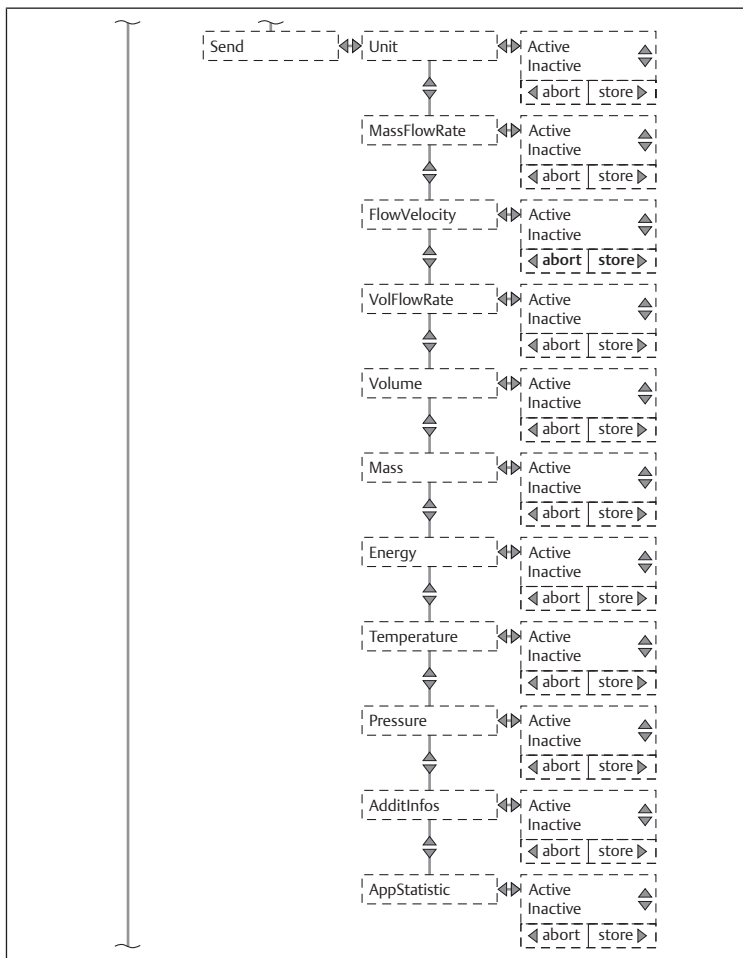

Fig. 22

Indice

1	Sulla presente documentazione	28
1.1	Validità della documentazione	28
1.2	Documentazione aggiuntiva	28
1.3	Abbreviazioni utilizzate	28
2	Sicurezza.....	28
2.1	Sul presente capitolo.....	28
3	Dati e parametri	28
3.1	Indicazioni sulla sicurezza	28
3.2	Dati dei parametri	28
3.2.1	Impostazioni generali.....	28
3.2.2	Impostazioni per la variante IO-Link	31
3.2.3	Impostazioni per la variante Ethernet	33

1 Sulla presente documentazione

Le presenti istruzioni contengono informazioni importanti per l'uso sicuro e corretto del prodotto.

Questa documentazione è un complemento alle istruzioni di montaggio valide. Leggere completamente le istruzioni di montaggio prima di utilizzare il prodotto.

1.1 Validità della documentazione

La presente documentazione è destinata a:

Programmatore, personale addetto alla manutenzione, gestore dell'impianto

La presente documentazione fornisce informazioni supplementari sull'uso delle seguenti varianti di prodotto della serie AF2 e 652/653:

Serie	Variante di prodotto	Interfaccia
AF2	Combinazione di filtri sensori (AS)	IO-Link Ethernet
	Sensore High Flow (HF)	IO-Link Ethernet
652	Variante di prodotto con filtro	IO-Link (A) Ethernet (B)
	Variante di prodotto con tubo	IO-Link (A) Ethernet (B)
653	Variante di prodotto con filtro	IO-Link (A) Ethernet (B)
	Variante di prodotto con tubo	IO-Link (A) Ethernet (B)

1.2 Documentazione aggiuntiva

Osservare la seguente documentazione correlata:

- Documentazione dell'impianto del produttore
- Documentazione dei restanti componenti dell'impianto
- Istruzioni di montaggio (R412026496 o 549411)

1.3 Abbreviazioni utilizzate

Nella presente documentazione sono utilizzate le seguenti abbreviazioni:

Abbreviazione	Significato
ABS	Acrilnitrile-butadiene-stirene
GF	Fibra di vetro
HF	High Flow
MBE	Valore finale del campo di misurazione
MQTT	Message Queuing Telemetry Transport
MTTF	Mean Time To Failure (durata di funzionamento media fra i guasti)
NPT	National Taper Pipe (tipo di filettatura gas)
OLED	Organic Light Emitting Diode (diodo organico a emissione di luce)
OPC UA	Open Platform Communications Unified Architecture
PA	Poliammide
PC	Policarbonato
DPI	Dispositivi di protezione individuali
Pt	Resistore di precisione in platino

2 Sicurezza

2.1 Sul presente capitolo

- Leggere il capitolo Sicurezza delle presenti istruzioni di montaggio e l'intera documentazione attentamente e completamente prima di utilizzare il prodotto.
- Conservare la documentazione in modo che sia sempre accessibile a tutti gli utenti.

3 Dati e parametri

3.1 Indicazioni sulla sicurezza

- Non effettuare alcuna modifica parametro in fase di funzionamento (prevenzione delle lesioni).

3.2 Dati dei parametri

3.2.1 Impostazioni generali

L'impostazione dei parametri in questo paragrafo vale per tutte le varianti del prodotto.

Generalità

Scopo	Menu	Opzione
Eseguire le impostazioni	Visualizzazione standard	Premere un qualunque tasto freccia per minimo 2 secondi per accedere al rispettivo menu ed eseguire le impostazioni.

Display

Scopo	Sottomenu	Opzione
Impostare le unità	Units	Scegliere tra i seguenti menu: <ul style="list-style-type: none">• <i>MassFlowRate</i>• <i>FlowVelocity</i>• <i>Volume</i>• <i>VolFlowRate</i>• <i>Mass</i>• <i>Energy</i>• <i>Temperature</i>• <i>Pressure</i>
Impostare la visualizzazione Screen 1.1	Pages	<ul style="list-style-type: none">• Selezionare <i>Disp1Top</i>• Selezionare <i>Disp1Btm</i>
Impostare la visualizzazione Screen 1.2	Pages	<ul style="list-style-type: none">• Selezionare <i>Disp2Top</i>• Selezionare <i>Disp2Btm</i>
Impostare la visualizzazione Screen 1.3	Pages	<ul style="list-style-type: none">• Selezionare <i>Disp3Top</i>• Selezionare <i>Disp3Btm</i>
Impostare la visualizzazione Screen 2.1, 2.2 e 2.3	Pages	Selezionare nel menu <i>DispHistory</i> i parametri di visualizzazione
Ottimizzare la leggibilità	Rotation	Impostare la visualizzazione 0° , 90° , 180° o 270°
Attivare lo screen saver	ScreenSaver	Impostare il tempo per l'attivazione dello screen saver
Spegnimento del display	AutoOff	Impostare il tempo per lo spegnimento del display
Regolare la luminosità	Brightness	Impostare la luminosità in percentuale
Assegnare un pin per la protezione da azionamento e manomissioni	Display Pin	Assegnare un pin a 4 cifre

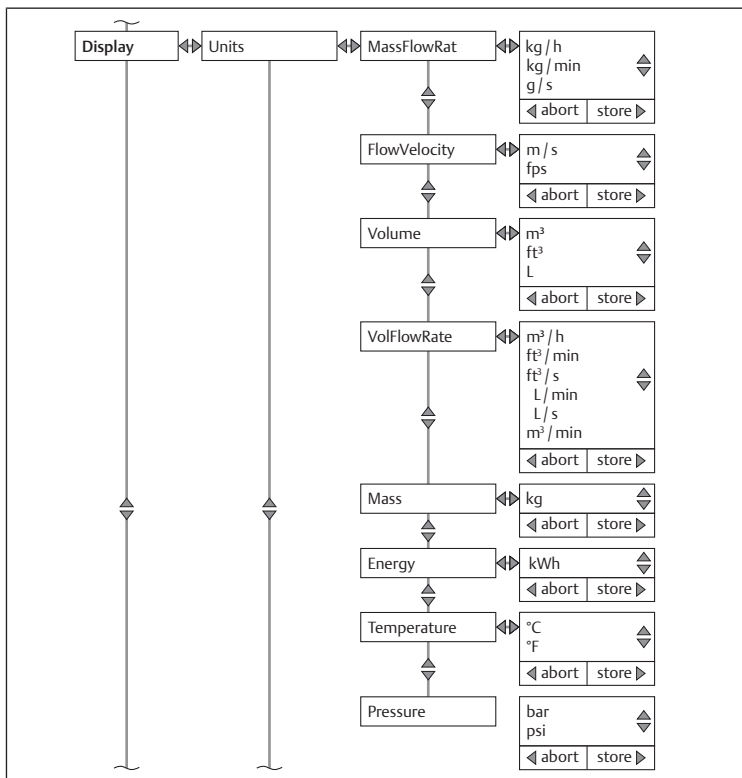

Fig. 1

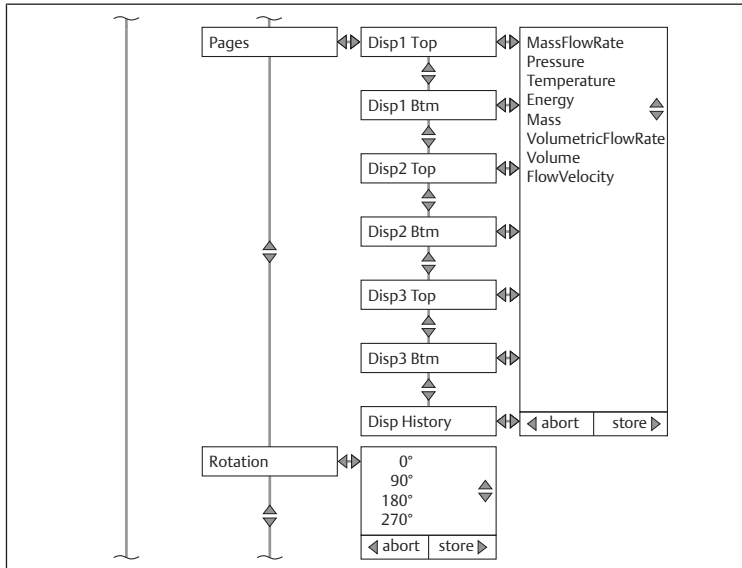

Fig. 2

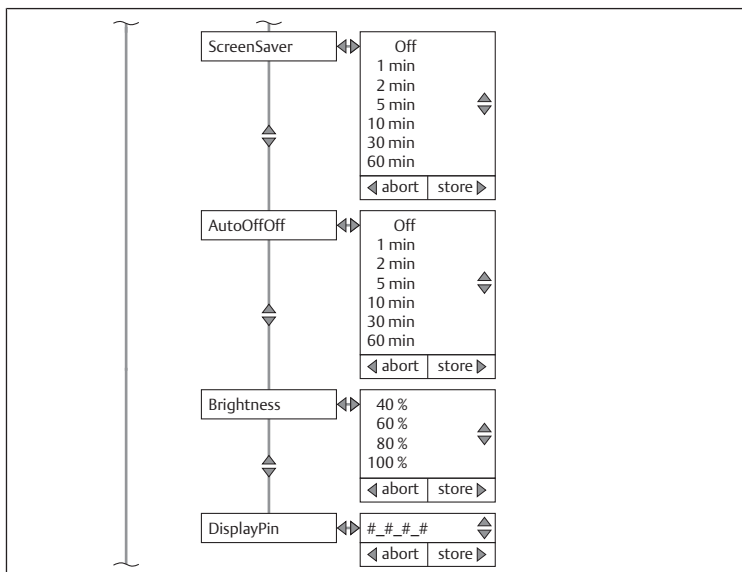

Fig. 3

Simulate

Scopo	Sottomenu	Opzione
Simulare la portata	Flow	Simulare la portata
Simulare la temperatura	Temperature	Simulare la temperatura
Simulare la pressione	Pressure	Simulare la pressione

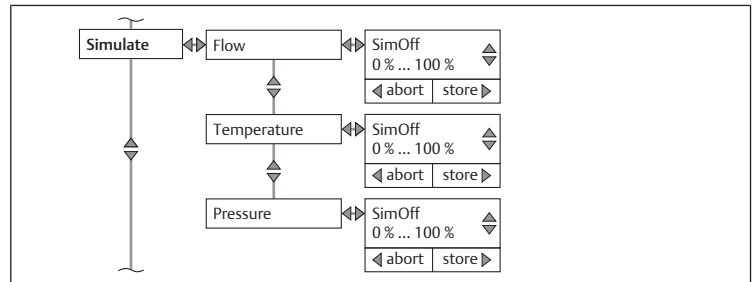

Fig. 4

Measure

Scopo	Sottomenu	Opzione
Impostare il fluido di misurazione	Flow	Selezionare l'opzione <i>Medium</i> e impostare il fluido di misurazione: <ul style="list-style-type: none"> • <i>Air</i> • <i>Argon</i> • <i>CO2</i> • <i>Nitrogen</i>
Impostare la norma/lo standard di riferimento	Flow	Selezionare l'opzione <i>RefCond</i> e impostare la norma/lo standard di riferimento: <ul style="list-style-type: none"> • <i>ISO 2533</i> • <i>ISO 1217</i> • <i>DIN 1945-1</i> • <i>DIN 1343</i> • <i>ISO 6358</i> • <i>ISO 8778</i> • <i>UserDefined</i> (definito dall'utente)
Impostare la pressione di riferimento con impostazione definita dall'utente (UserDefined)	Flow	Selezionare l'opzione <i>RefCond</i> e selezionare <i>UserDefined</i> (pressione di riferimento definita dall'utente)
Impostare l'offset zero	Flow	Selezionare l'opzione <i>0-FlowwOff</i> e impostare l'offset zero
Impostare il taglio di bassa portata	Flow	Selezionare l'opzione <i>0-FlowCut</i> e impostare il taglio di bassa portata
Filtro del valore medio per livellare i valori di misura nella visualizzazione e nell'uscita	Flow/Pressure/Temperature	Selezionare l'opzione <i>Filter</i> e impostare il filtro dei valori di misura
Impostare l'offset/offset zero	Pressure/Temperature	Selezionare l'opzione <i>Offset</i> e impostare l'offset/spostamento del punto zero
Scegliere la qualità del segnale	SigQuality	Scegliere tra <i>SigQua1</i> , <i>SigQua2</i> , <i>SigQua3</i> e <i>SigQua4</i> . La qualità è impostata per tutte al 100%. La qualità del segnale 1 è una misura per la robustezza

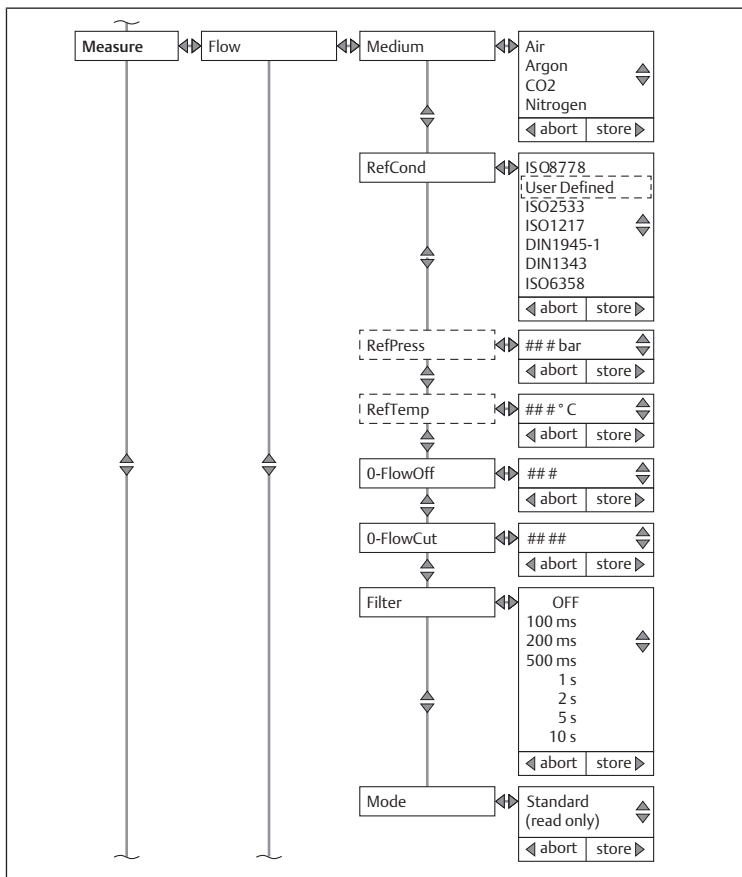

Fig. 5

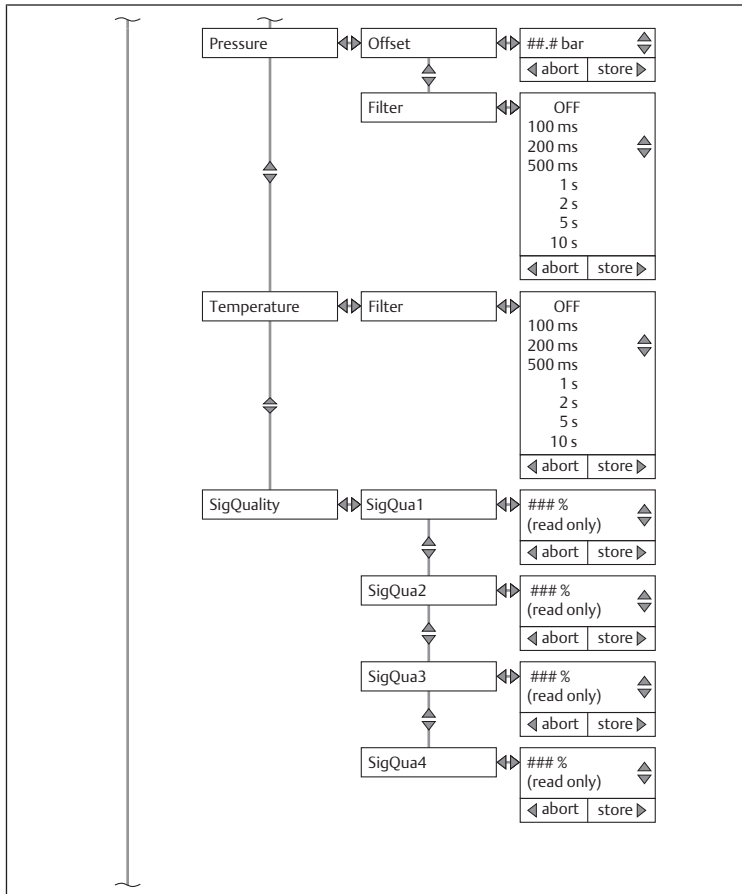

Fig. 6

History

Scopo	Sottomenu	Opzione
Scegliere la visualizzazione/il grafico dei valori di misura degli ultimi 60 minuti	60 min	Selezionare la visualizzazione/il grafico dei valori di misura degli ultimi 60 minuti

Scopo	Sottomenu	Opzione
Scegliere la visualizzazione/il grafico dei valori di misura delle ultime 24 ore	24 hour	Selezionare la visualizzazione/il grafico dei valori di misura delle ultime 24 ore
Scegliere la visualizzazione/il grafico dei valori di misura degli ultimi 7 giorni	7 days	Selezionare la visualizzazione/il grafico dei valori di misura degli ultimi 7 giorni

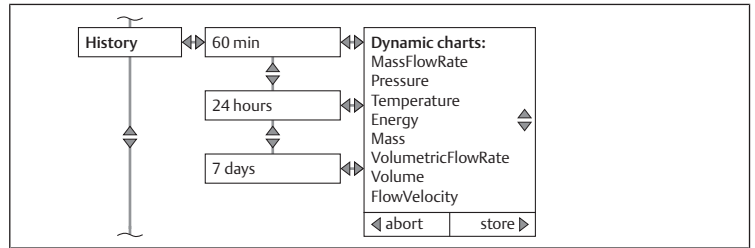

Fig. 7

Statistics

Scopo	Sottomenu	Opzione
Valori minimi, medi e massimi dei singoli parametri dall'ultimo reset	View	Visualizzare <i>Max, mean, min values</i> dei singoli parametri dopo l'ultimo reset
Visualizzare il momento dell'ultimo reset (read only)	LastReset	Visualizzare il momento dell'ultimo reset
Azzerare i valori statistici	Reset	Azzerare i valori statistici

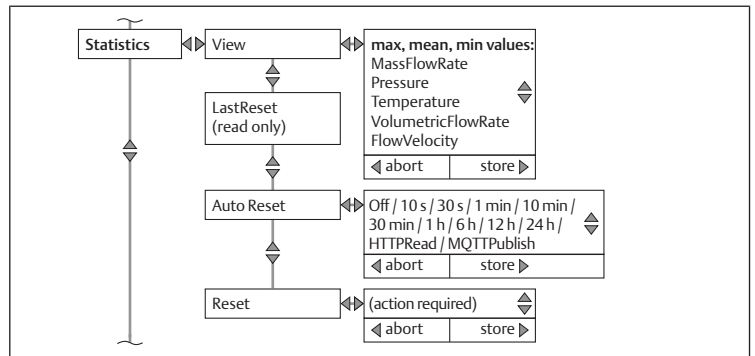

Fig. 8

Counter

Scopo	Sottomenu	Opzione
Visualizzare il contatore		Scegliere tra i sottomenu <i>Mass, Volume, Energy</i> e <i>LastReset</i> e visualizzare i contatori
Resettare i contatori	Reset	Resettare i contatori

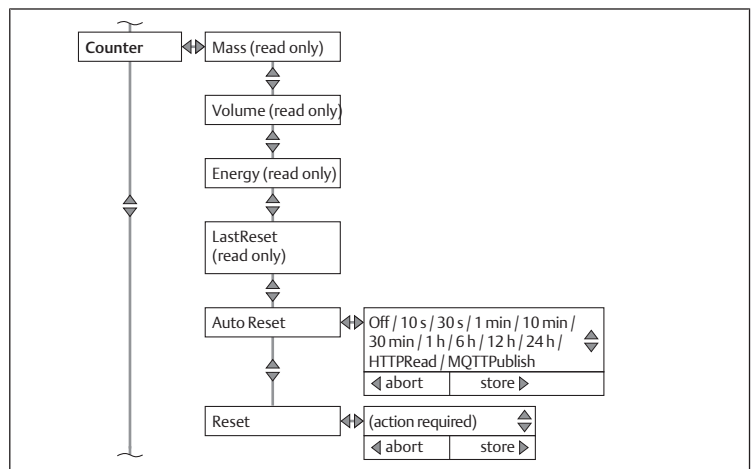

Fig. 9

Sistema

Scopo	Sottomenu	Opzione
Login per il servizio assistenza	Service	Predisporre il login del servizio assistenza per utenti autorizzati

Scopo	Sottomenu	Opzione
Ripristinare le impostazioni di fabbrica	FactReset	Resettare il sistema alle impostazioni di fabbrica
Serial Number (read only)	SerialNumber	Visualizzare il numero di serie
Impostare il tag dispositivo	DevTag	Impostare il tag dispositivo
Impostare il tag Application	AppTag	Impostare il tag Application
FWVersion (read only)	FWVersion	Visualizzare la versione firmware
Calibration (read only)	Calibration	Visualizzare i valori di default del firmware
BLVersion (read only)	BLVersion	Visualizzare la versione boot load
HWVersion (read only)	HWVersion	Visualizzare la versione hardware

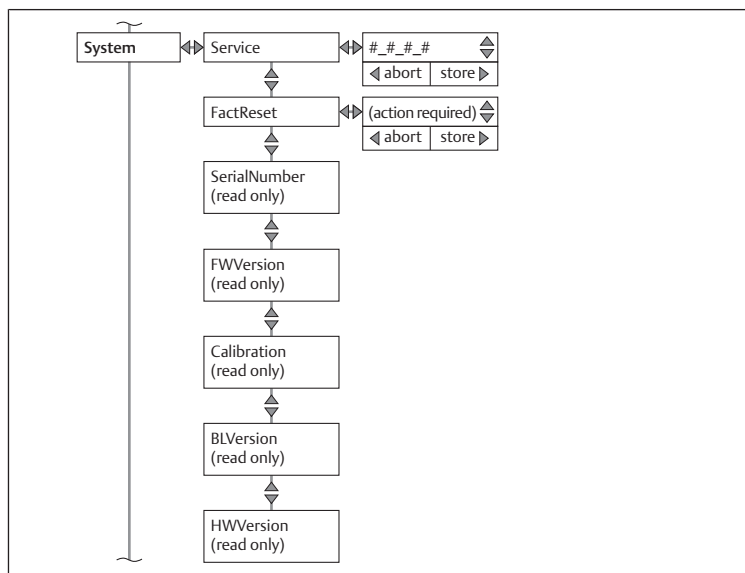

Fig. 10

Tag

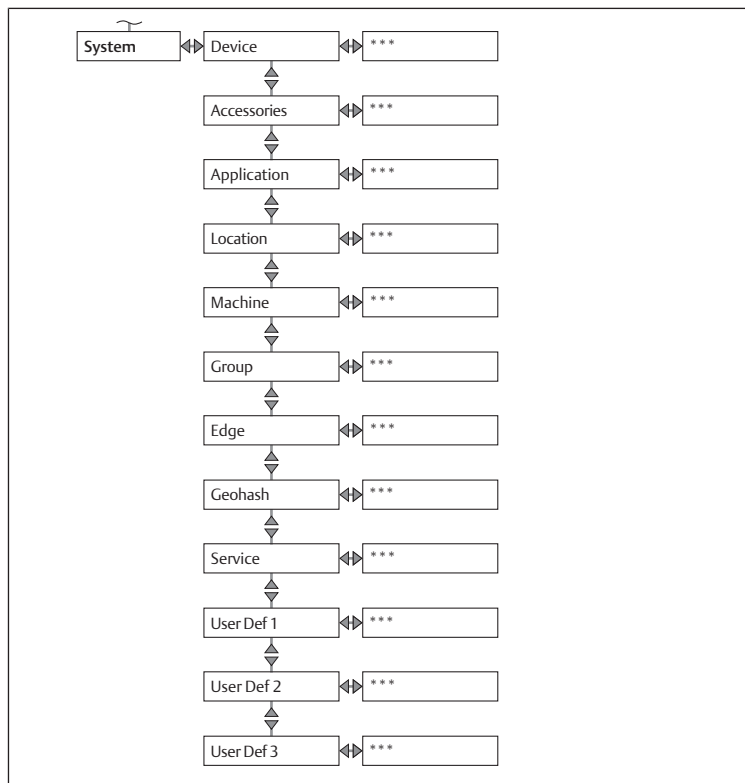

Fig. 11

3.2.2 Impostazioni per la variante IO-Link

Le impostazioni valgono per tutte le varianti del prodotto con attacco elettrico IO-Link.

IO-Link

Il display mostra il menu dei valori di misura con l'impostazione di default (kg/h, m/s).

Scopo	Menu	Opzione
Selezionare il menu	Visualizzazione standard	Premere un qualunque tasto freccia per minimo 2 secondi e scegliere tra i menu Q1 Menu , Q2 Menu e Qa Menu .
Impostare l'uscita di commutazione	Q1 Menu	Impostare l'uscita di commutazione
Impostare l'uscita di commutazione	Q2 Menu	Impostare l'uscita di commutazione
Impostare l'uscita analogica	Qa Menu	Impostare l'uscita analogica

Q1 Menu

Il menu Q1 contiene le impostazioni dell'uscita di commutazione 1.

Scopo	Sottomenu	Opzione
Impostazione dell'isteresi o della funzione finestra	Mode	Definire l'impostazione della modalità per l'isteresi o la funzione finestra con i rispettivi parametri di misura
Impostare il punto di commutazione	SetPoint1	Impostare il punto di commutazione
Impostare il punto di reinserzione/isteresi o il limite dell'intervallo inferiore	SetPoint2	Impostare il punto di reinserzione/isteresi o il limite dell'intervallo inferiore
Impostare il comportamento di commutazione del contatto di apertura	Polarity	Scegliere tra NormallyClosed e NormallyOpen
Simulare l'uscita di commutazione	Simulate	Selezionare Active , Inactive o Normal (modalità di misurazione)
Impostare PNP/NPN o Push/Pull (DRV)	DriverType	Impostare PNP/NPN o Push/Pull (DRV)

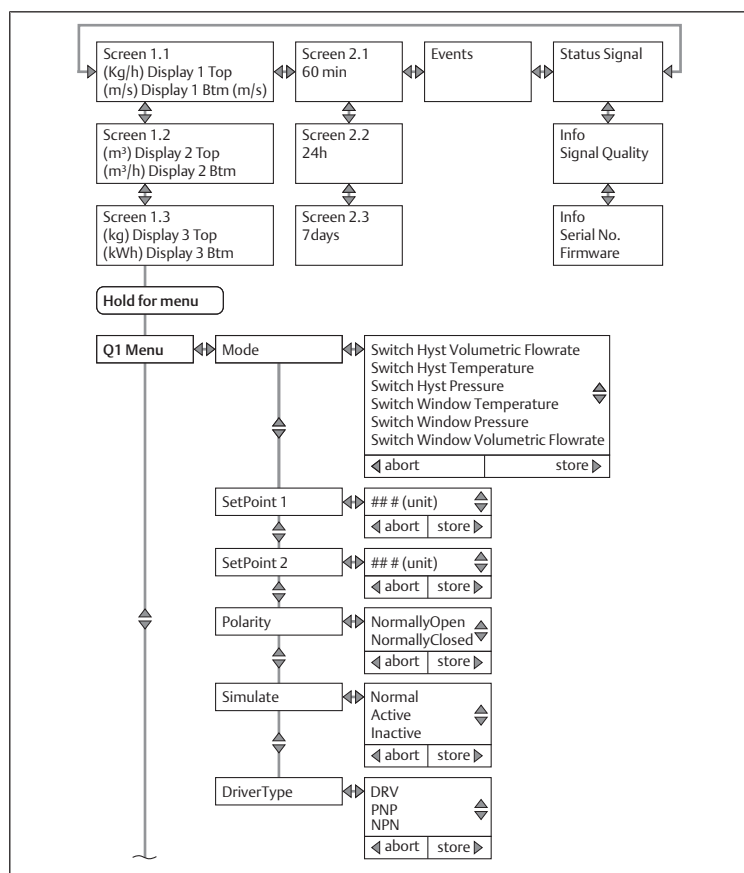

Fig. 12

Q2 Menu

Il menu Q2 contiene le impostazioni dell'uscita di commutazione 2.

Scopo	Sottomenu	Opzione
Impostare l'uscita di commutazione come uscita di frequenza, di impulso, analogica o di commutazione	Function	Impostare l'uscita di commutazione come <i>Switch</i> , <i>Frequency</i> , <i>Pulse</i> o <i>Analog</i>
Impostare la modalità per isteresi o funzione finestra	Mode	Impostare la modalità per isteresi o funzione finestra
Impostare il punto di commutazione	SetPoint1	Impostare il punto di commutazione
Impostare il punto di reinserzione/isteresi o il limite dell'intervallo inferiore	SetPoint2	Impostare il punto di reinserzione/isteresi o il limite dell'intervallo inferiore
Impostare il comportamento di commutazione del contatto di apertura	Polarity	Scegliere tra <i>NormallyClosed</i> e <i>NormallyOpen</i>
Simulare l'uscita di commutazione	Simulate	Scegliere tra <i>Active</i> , <i>Inactive</i> e <i>Normal</i> (modalità di misurazione)
Impostare PNP/NPN o Push/Pull	DriverType	Impostare <i>PNP/NPN</i> o <i>Push/Pull</i>

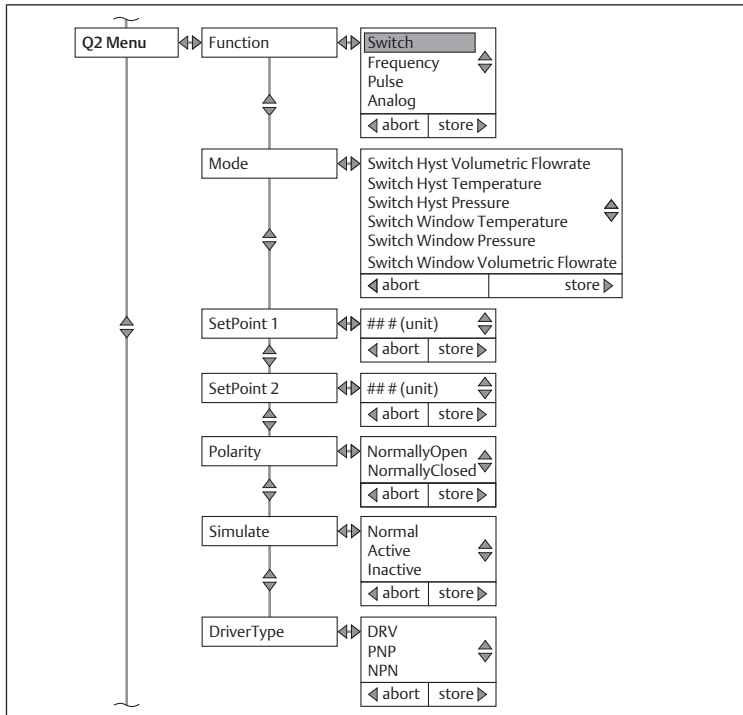

Fig. 13

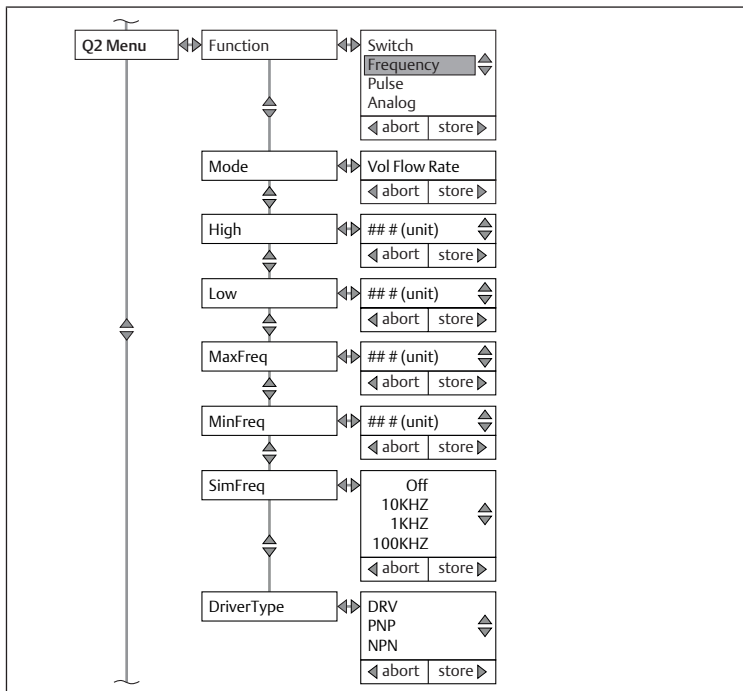

Fig. 14

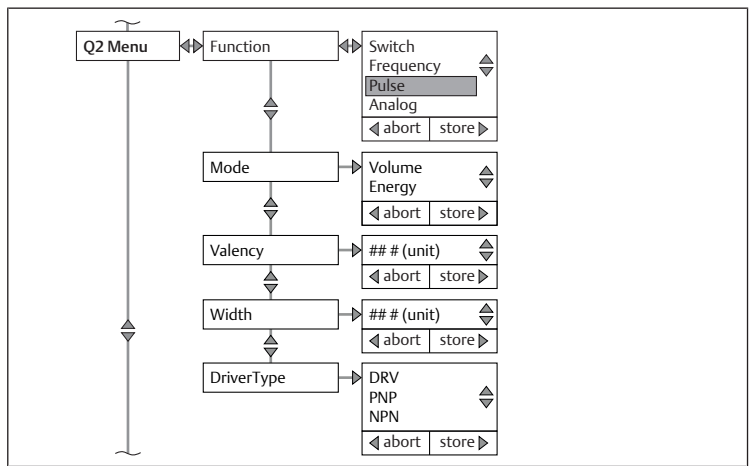

Fig. 15

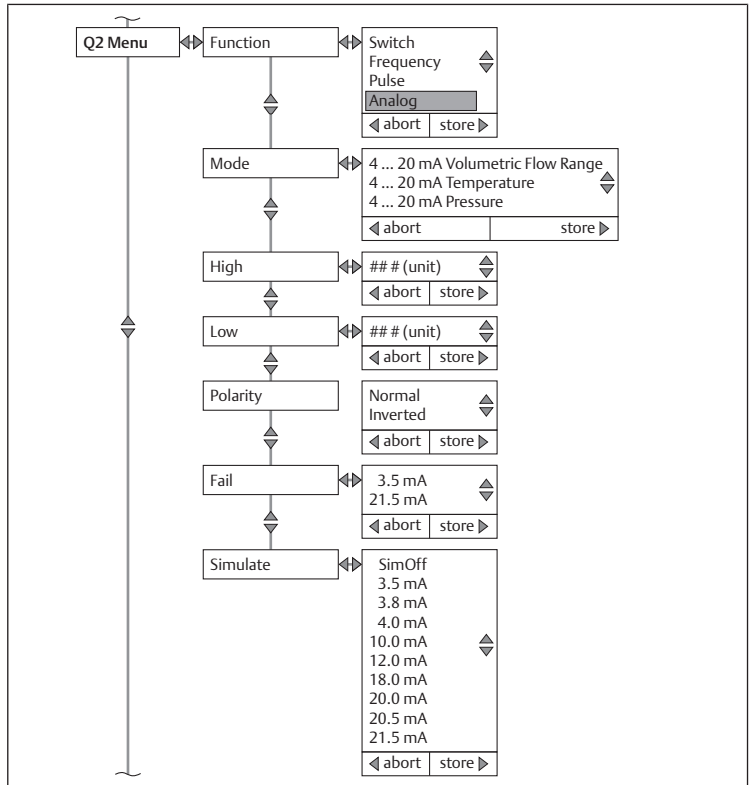

Fig. 16

Qa Menu

Il menu Qa contiene le impostazioni dell'uscita analogica.

Scopo	Sottomenu	Opzione
Assegnare i parametri di misura all'uscita corrente	Mode	Assegnare i parametri di misura come portata, temperatura o pressione all'uscita corrente
Assegnare il valore finale del campo di misurazione	High	Impostare il valore finale del campo di misurazione a 20 mA
Assegnare l'inizio del campo di misurazione	Low	Impostare l'inizio del campo di misurazione a 4 mA
Impostare l'inversione dell'uscita corrente	Polarity	Impostare l'inversione dell'uscita corrente
Impostare il comportamento dell'uscita corrente in caso di errore nel prodotto	Fail	Impostare il comportamento dell'uscita corrente in caso di errore nel prodotto
Impostare un valore di corrente predefinito	Simulate	Impostare un valore di corrente predefinito

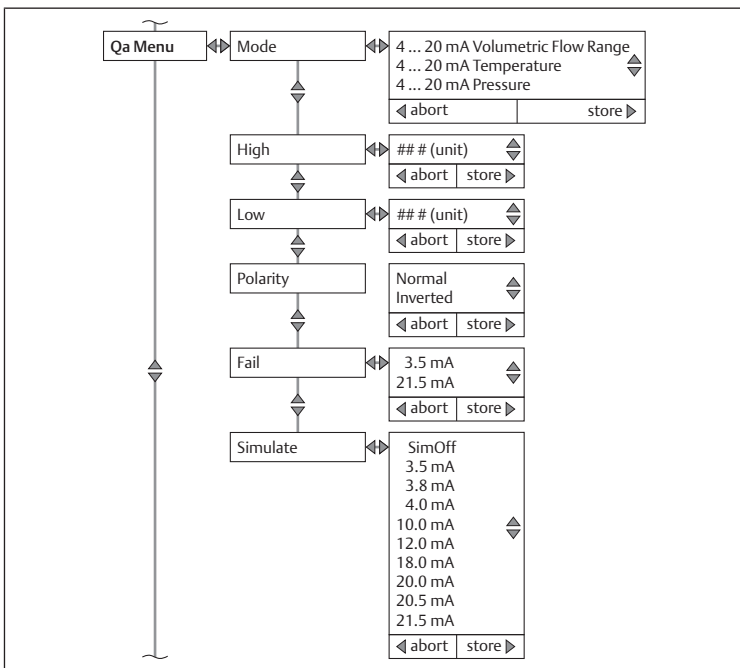

Fig. 17

3.2.3 Impostazioni per la variante Ethernet

Le impostazioni valgono per tutte le varianti del prodotto con attacco elettrico Ethernet.

Ethernet

Scopo	Sottomenu	Opzione
Assegnare un indirizzo statico o dinamico	DHCP Mode	Assegnare un indirizzo
Impostare l'indirizzo IP	IP Address	Impostare l'indirizzo IP
SubNetMask	SubNetMask	Impostare la maschera di sottorete SubNetMask
Gateway	Gateway	Impostare l'indirizzo gateway
Nome	Nome	Impostare i nomi DHCP

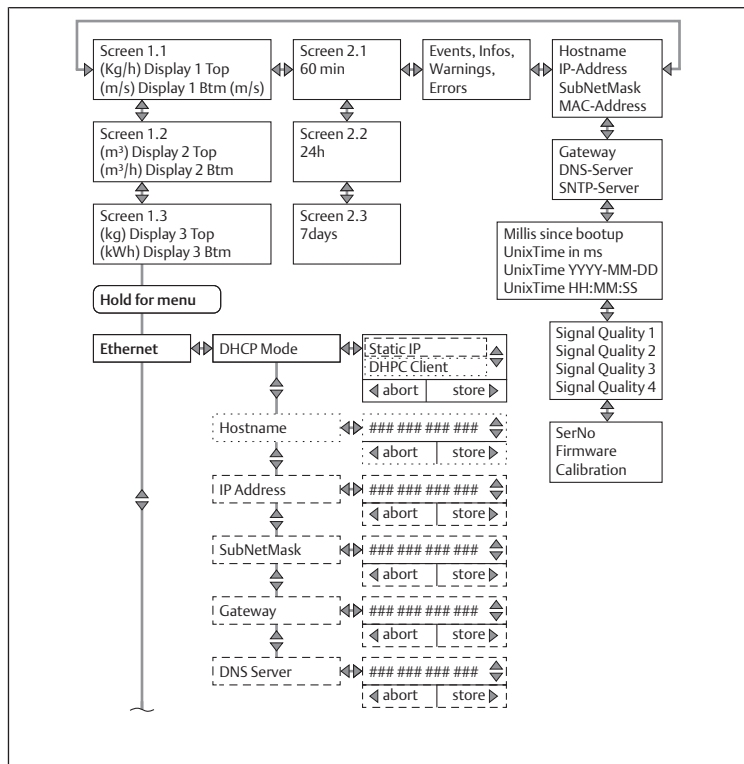
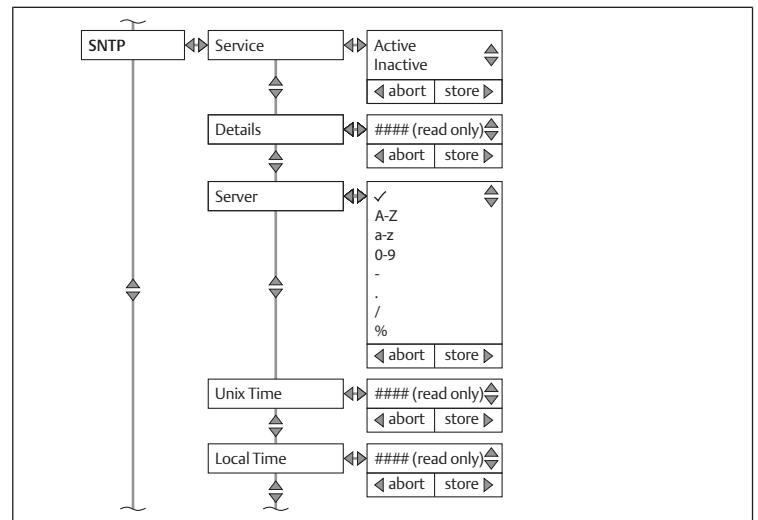

Fig. 18

SNTP



Webserver

Scopo	Sottomenu	Opzione
Attivare e disattivare l'interfaccia web	State	Scegliere tra <i>Active</i> e <i>Inactive</i>
Impostare la porta	Port	Selezionare la porta del server web. La porta standard per il servizio HTTP è la 80
Resetare la password utente	ResetPW	Resetare la password utente del server web "Maintenance" allo stato di consegna. La password di default (impostazione di fabbrica) è "airflow-sensor"

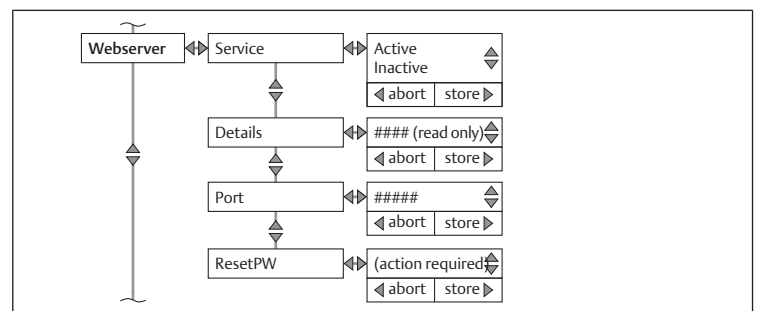

Fig. 19

OPC UA

Scopo	Sottomenu	Opzione
Attivare e disattivare l'interfaccia web	State	Scegliere tra <i>Active</i> e <i>Inactive</i>
Impostare la porta	Port	Impostare la porta
Impostare il nome utente	User	Impostare il nome utente
Assegnare una password	Password	Impostare la password

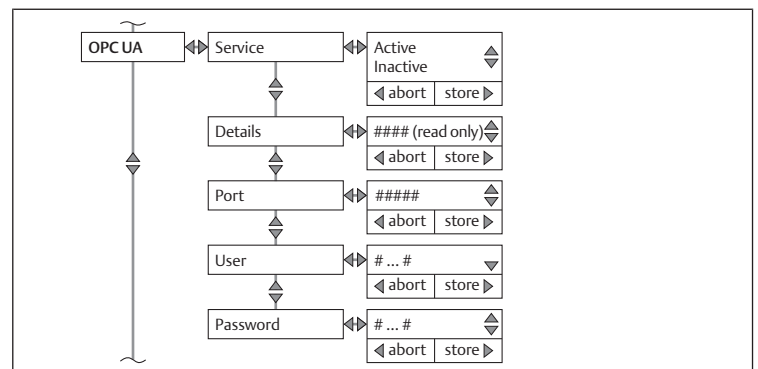

Fig. 20

MQTT

Scopo	Sottomenu	Opzione
Attivare e disattivare l'interfaccia web	State	Scegliere tra <i>Active</i> e <i>Inactive</i>
Broker	Broker	Impostare il broker
Impostare la porta	Port	Impostare la porta
Topic	Topic	Visualizzare gli argomenti
User	User	Inserire il nome utente per il broker
Creare la password per il broker	Password	Inserire la password per il broker
Inviare l'intervallo al broker	Update	Impostare l'intervallo
QoS	QoS	Selezionare <i>QoS-0</i> , <i>QoS-1</i> o <i>QoS-2</i>
Definire il messaggio MQTT al Send broker	Send	Selezionare la voce del menu dal secondo sottomenu e impostare <i>Active</i> o <i>Inactive</i>

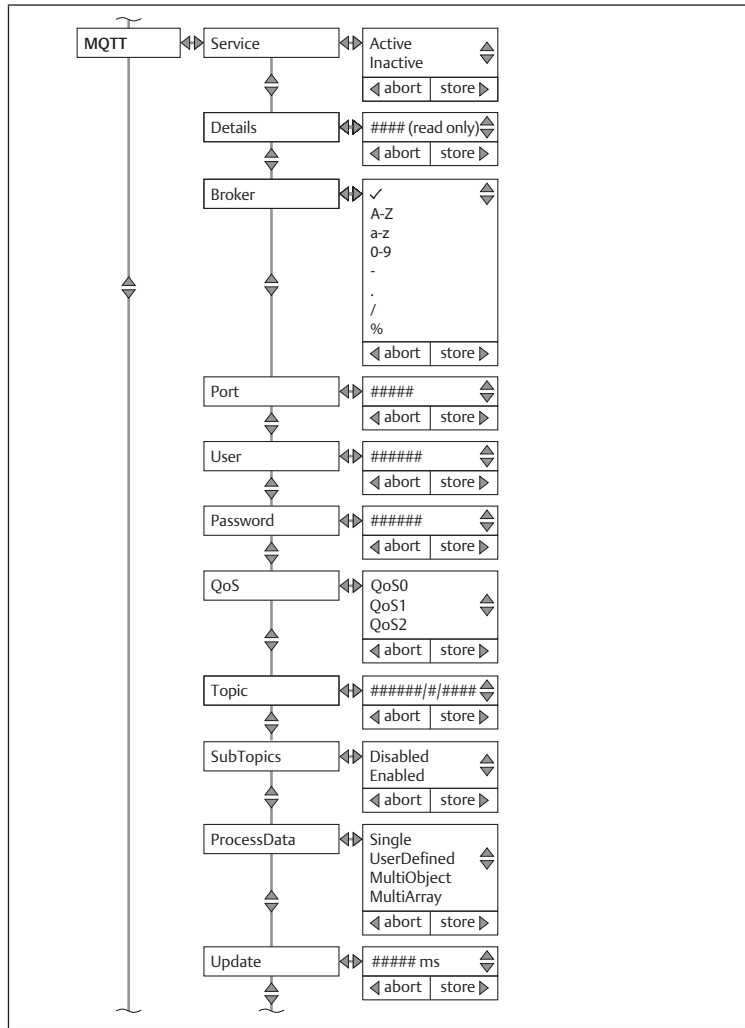

Fig. 21

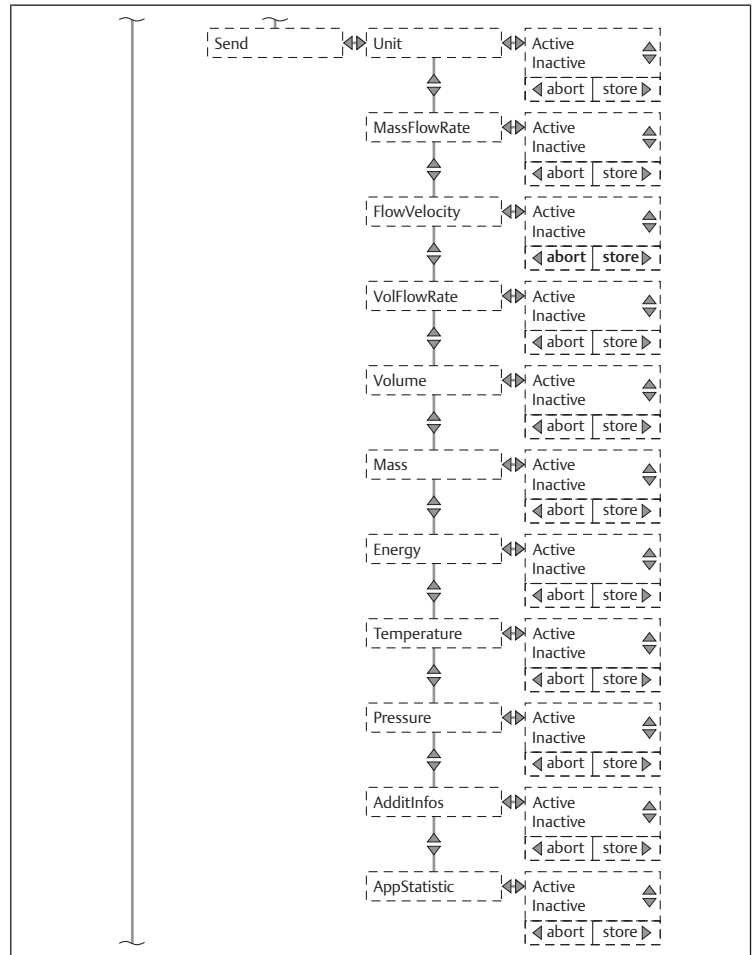

Fig. 22

Índice de contenidos

1	Acerca de esta documentación	36
1.1	Validez de la documentación	36
1.2	Documentación adicional	36
1.3	Abreviaturas utilizadas	36
2	Seguridad	36
2.1	Acerca de este capítulo	36
3	Datos y parámetros	36
3.1	Notas sobre seguridad	36
3.2	Datos de parámetros	36
3.2.1	Ajustes generales	36
3.2.2	Ajustes de la variante IO-Link	39
3.2.3	Ajustes de la variante Ethernet	41

1 Acerca de esta documentación

Estas instrucciones contienen información importante para la manipulación segura y adecuada del producto.

Esta documentación es un complemento de las instrucciones de montaje aplicables. Lea completamente las instrucciones de montaje antes de trabajar con el producto.

1.1 Validez de la documentación

Esta documentación está dirigida a:

Programadores, personal de servicio, operadores de instalaciones

Esta documentación proporciona información complementaria para la manipulación de las siguientes variantes de producto de presión de la serie AF2 y 652/653:

Serie	Variante de producto	Interfaz
AF2	Combinaciones de filtros de sensores (AS)	IO-Link Ethernet
	Sensor High Flow (HF)	IO-Link Ethernet
652	Variante de producto de filtro	IO-Link (A) Ethernet (B)
	Variante de producto de manguera	IO-Link (A) Ethernet (B)
653	Variante de producto de filtro	IO-Link (A) Ethernet (B)
	Variante de producto de manguera	IO-Link (A) Ethernet (B)

1.2 Documentación adicional

Tenga en cuenta la siguiente documentación aplicable:

- Documentación de la instalación del fabricante
- Documentación de otros componentes de la instalación
- Instrucciones de montaje (R412026496 o 549411)

1.3 Abreviaturas utilizadas

En esta documentación se utilizan las siguientes abreviaturas:

Abreviatura	Significado
ABS	Acrilonitrilo butadieno estireno
GF	Fibra de vidrio
HF	High Flow
MBE	Valor final del margen de medición
MQTT	Message Queuing Telemetry Transport
MTTF	Mean Time To Failure (duración media de funcionamiento hasta el fallo)
NPT	National Taper Pipe (tipo de rosca de tubo)
OLED	Organic Light Emitting Diode (diodo emisor de luz orgánico)
OPC UA	Open Platform Communications Unified Architecture
PA	Poliamida
PC	Policarbonato
EPI	Equipo de protección individual
Pt	Resistencia de medición de platino

2 Seguridad

2.1 Acerca de este capítulo

- Lea el capítulo sobre seguridad de las instrucciones de montaje y toda la documentación a fondo y por completo antes de trabajar con el producto.
- Conserve la documentación para que sea accesible a todos los usuarios en todo momento.

3 Datos y parámetros

3.1 Notas sobre seguridad

- No realizar cambios en los parámetros durante el funcionamiento en curso (prevención de accidentes).

3.2 Datos de parámetros

3.2.1 Ajustes generales

El ajuste de los parámetros en esta sección se aplica a todas las variantes del producto.

Generalidades

Objetivo	Menú	Opción
Realizar ajustes	Indicación estándar	Pulsar cualquier tecla de flecha durante al menos 2 segundos y realizar los ajustes en el menú correspondiente.

Pantalla

Objetivo	Submenú	Opción
Ajustar las unidades	Units	Seleccionar entre los siguientes menús: <ul style="list-style-type: none">• <i>MassFlowRate</i>• <i>FlowVelocity</i>• <i>Volume</i>• <i>VolFlowRate</i>• <i>Mass</i>• <i>Energy</i>• <i>Temperature</i>• <i>Pressure</i>
Ajustar la indicación Screen 1.1	Pages	<ul style="list-style-type: none">• Seleccionar <i>Disp1Top</i>• Seleccionar <i>Disp1Btm</i>
Ajustar la indicación Screen 1.2	Pages	<ul style="list-style-type: none">• Seleccionar <i>Disp2Top</i>• Seleccionar <i>Disp2Btm</i>
Ajustar la indicación Screen 1.3	Pages	<ul style="list-style-type: none">• Seleccionar <i>Disp3Top</i>• Seleccionar <i>Disp3Btm</i>
Ajustar la indicación Screen 2.1, 2.2 y 2.3	Pages	Seleccionar el parámetro de indicación <i>DispHistory</i> en el menú
Optimizar la legibilidad	Rotation	Ajustar la indicación 0°, 90°, 180° o 270°
Activar el protector de pantalla	ScreenSaver	Ajustar el tiempo para la activación del protector de pantalla
Desconectar la pantalla	AutoOff	Ajustar el tiempo para la desconexión de la pantalla
Ajustar el brillo	Brightness	Ajustar el brillo en porcentaje
Asignar un pin para la protección de uso o la protección contra manipulaciones	Display Pin	Asignar el pin de 4 dígitos

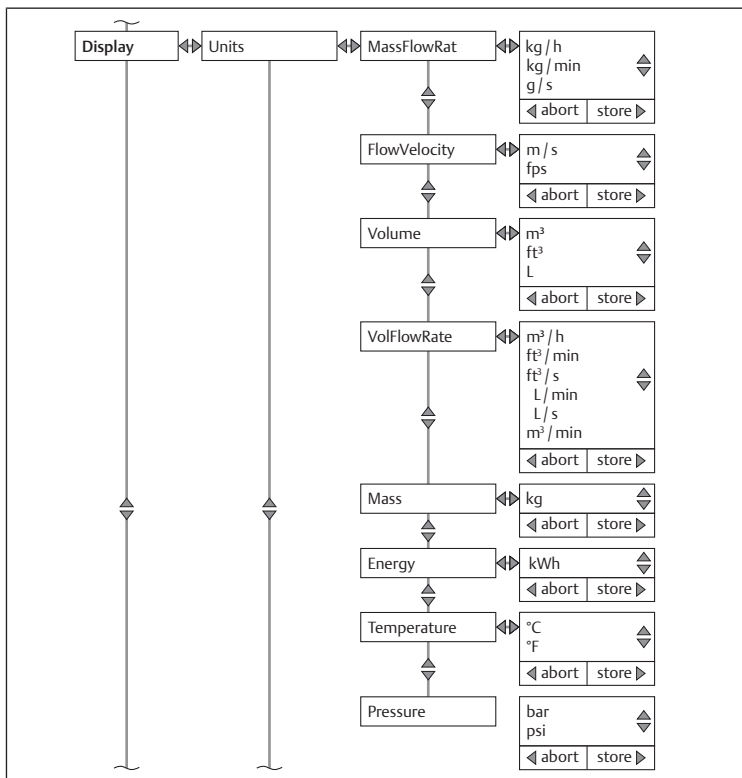

Fig. 1

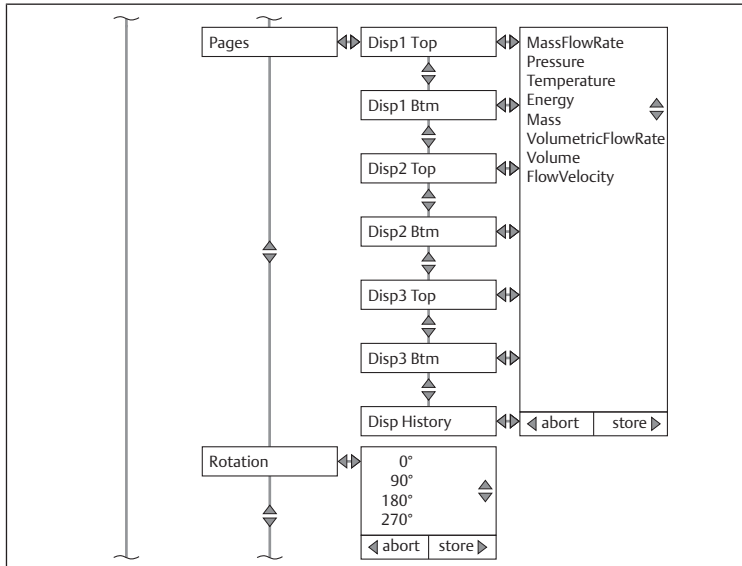

Fig. 2

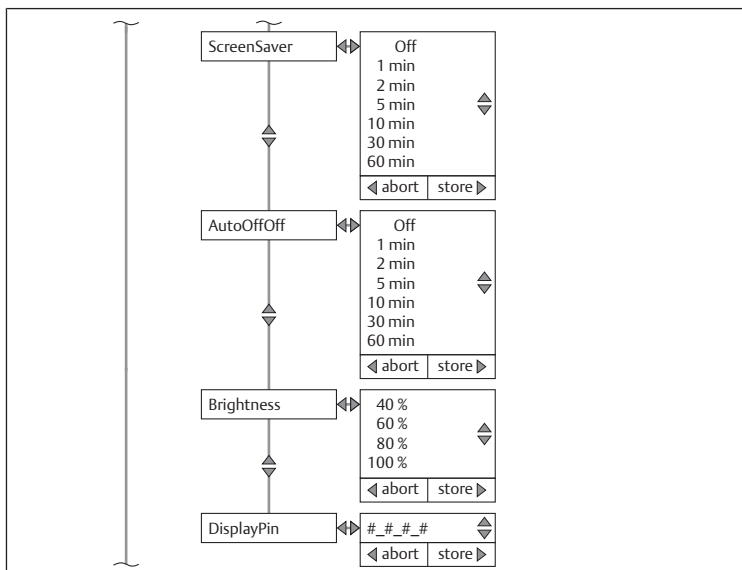

Fig. 3

Simular

Objetivo	Submenú	Opción
Simular el caudal	Flow	Simular el caudal
Simular la temperatura	Temperature	Simular la temperatura
Simular la presión	Pressure	Simular la presión

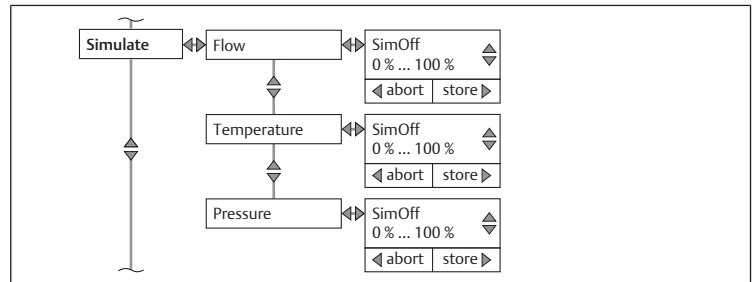

Fig. 4

Measure

Objetivo	Submenú	Opción
Ajustar el medio de medición	Flow	Seleccionar la opción Medium y ajustar el medio de medición: <ul style="list-style-type: none"> Air Argon CO2 Nitrogen
Ajustar la norma/estándar de referencia	Flow	Seleccionar la opción RefCond y ajustar la norma/estándar de referencia: <ul style="list-style-type: none"> ISO 2533 ISO 1217 DIN 1945-1 DIN 1343 ISO 6358 ISO 8778 UserDefined (específico de usuario)
Establecer la presión de referencia con el ajuste específico de la aplicación (UserDefined)	Flow	Seleccionar la opción RefCond y UserDefined (presión de referencia específica de usuario)
Ajustar el desplazamiento de punto cero	Flow	Seleccionar la opción 0-Flow-Off y ajustar el desplazamiento de punto cero
Ajustar la supresión de la cantidad de arrastre	Flow	Seleccionar la opción 0-Flow-Cut y ajustar la supresión de la cantidad de arrastre
Filtro de media para el alisamiento del valor medido en la pantalla y en la salida	Flow/Pressure/Temperature	Seleccionar la opción Filter y ajustar el filtro de valor medido
Ajustar offset/desplazamiento de punto cero	Pressure/Temperature	Seleccionar la opción Offset y ajustar offset/desplazamiento de punto cero
Seleccionar la calidad de la señal	SigQuality	Elegir entre SigQua1 , SigQua2 , SigQua3 y SigQua4 . La calidad se ajusta al 100% en cada caso. La calidad de la señal 1 es una medida de solidez

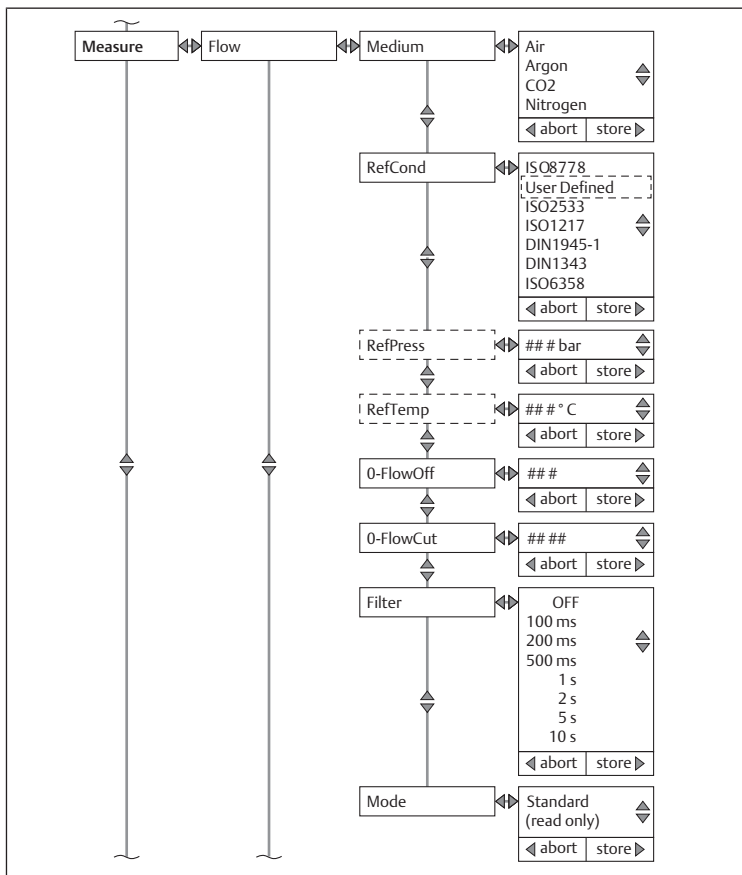

Fig. 5

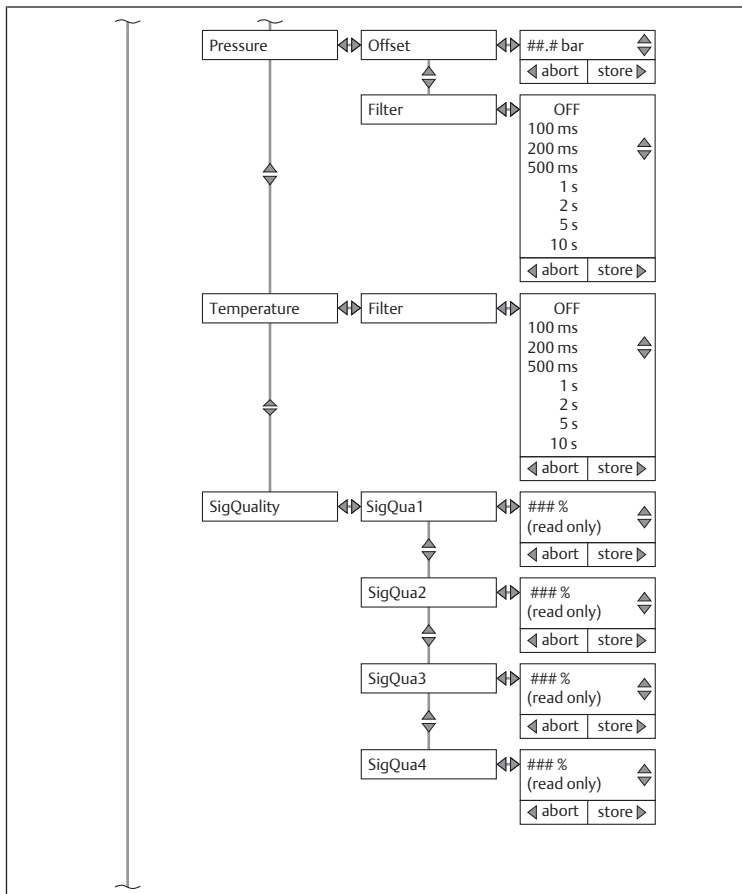

Fig. 6

History

Objetivo	Submenú	Opción
Seleccionar la indicación/gráfico de los valores medidos de las últimas 60 minutos	60 min	Seleccionar la indicación/gráfico de los valores medidos de las últimas 60 minutos
Seleccionar la indicación/gráfico de los valores medidos de las últimas 24 horas	24 hours	Seleccionar la indicación/gráfico de los valores medidos de las últimas 24 horas
Seleccionar la indicación/gráfico de los valores medidos de los últimos 7 días	7 days	Seleccionar la indicación/gráfico de los valores medidos de los últimos 7 días

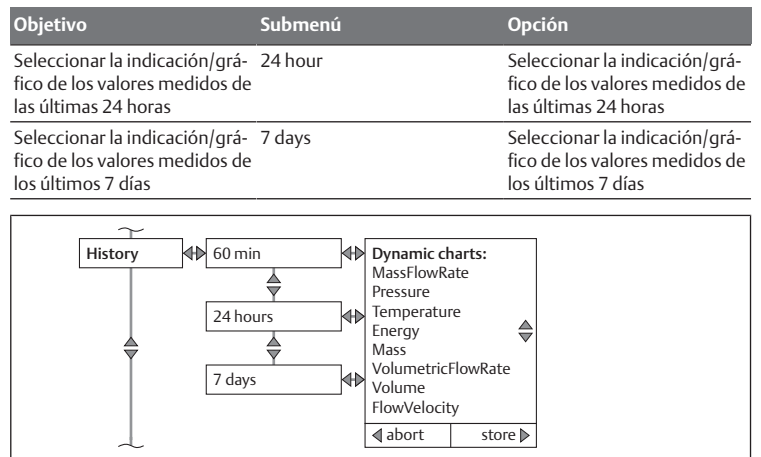

Fig. 7

Statistics

Objetivo	Submenú	Opción
Valores mínimos, valores medios y valores máximos de los parámetros individuales después del último reinicio	View	Visualizar <i>Max, mean, min values</i> de los parámetros individuales después del último reinicio
Visualizar la hora del último reinicio (solo lectura)	LastReset	Visualizar la hora del último reinicio
Restaurar los valores de estadística a 0	Reset	Restaurar los valores de estadística a 0

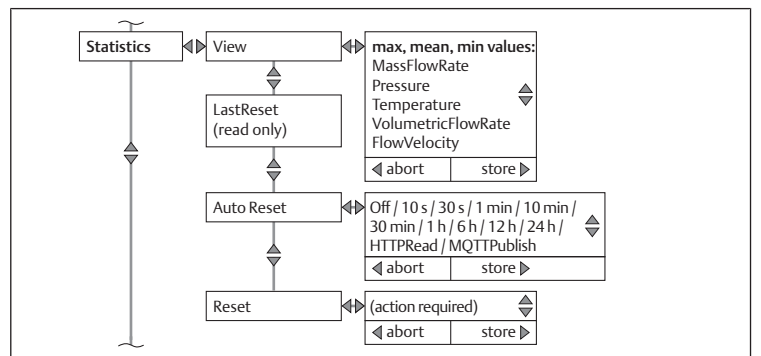

Fig. 8

Counter

Objetivo	Submenú	Opción
Visualizar el contador		Elegir entre los submenús <i>Mass, Volume, Energy</i> y <i>LastReset</i> y visualizar el contador
Reiniciar el contador	Reset	Reiniciar el contador

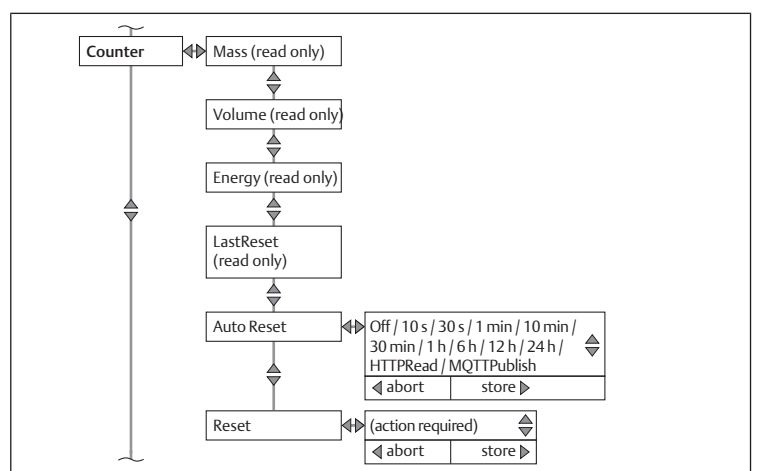

Fig. 9

System

Objetivo	Submenú	Opción
Service-Login	Service	Realizar el inicio de sesión del servicio (Service-Login) para el usuario autorizado
Restaurar a los ajustes de fábrica	FactReset	Restaurar el sistema a los ajustes de fábrica
Serial Number (read only)	SerialNumber	Visualizar el número de serie
Ajustar la etiqueta del aparato (Device-Tag)	DevTag	Ajustar la etiqueta del aparato (Device-Tag)
Ajustar la etiqueta de Application	AppTag	Ajustar la etiqueta de Application
FWVersion (read only)	FWVersion	Visualizar la versión del firmware
Calibration (read only)	Calibration	Visualizar los valores predeterminados del firmware
BLVersion (read only)	BLVersion	Visualizar Bootloadversion
HWVersion (read only)	HWVersion	Visualizar Hardwareversion

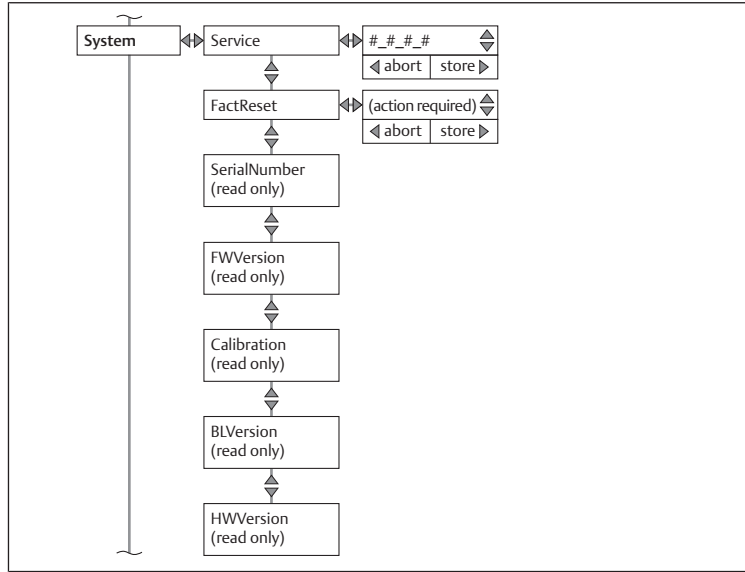

Fig. 10

Tags

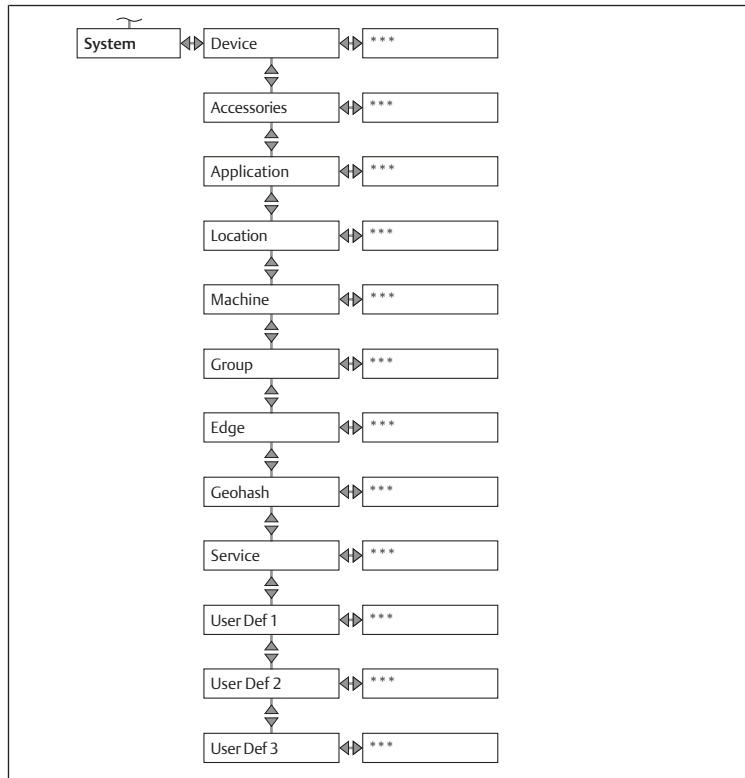

Fig. 11

3.2.2 Ajustes de la variante IO-Link

Los ajustes se aplican a todas las variantes del producto con la conexión eléctrica IO-Link.

IO-Link

La pantalla muestra el menú de valores medidos con la configuración por defecto (kg/h, m/s).

Objetivo	Menú	Opción
Seleccionar el menú	Indicación estándar	Pulsar cualquier tecla de flecha durante al menos 2 segundos y elegir entre Q1 Menu , Q2 Menu y Qa Menu .
Ajustar la salida de conmutación	Q1 Menu	Ajustar la salida de conmutación
Ajustar la salida de conmutación	Q2 Menu	Ajustar la salida de conmutación
Ajustar la salida analógica	Qa Menu	Ajustar la salida analógica

Q1 Menu

El menú Q1 contiene los ajustes de la salida de conmutación 1.

Objetivo	Submenú	Opción
Ajustar la histéresis o la función de ventana	Mode	Realizar el ajuste del modo para la histéresis o la función de ventana con los parámetros de medición asociados
Ajustar el punto de conmutación	SetPoint1	Ajustar el punto de conmutación
Ajustar el punto de retroceso/la histéresis o el límite inferior de la ventana	SetPoint2	Ajustar el punto de retroceso/la histéresis o el límite inferior de la ventana
Ajustar el comportamiento de conmutación del contacto de reposo	Polarity	Elegir entre NormallyClosed y NormallyOpen
Simular la salida de conmutación	Simulate	Seleccionar Active , Inactive o Normal (medición)
Ajustar PNP/NPN o Push/Pull (DRV)	DriverType	Ajustar PNP/NPN o Push/Pull (DRV)

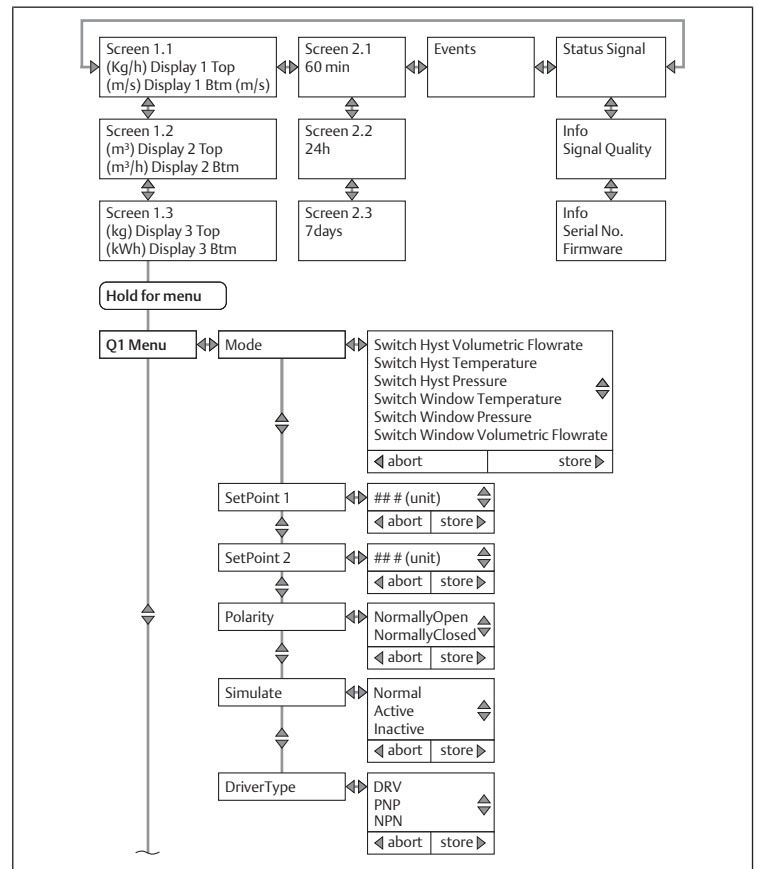

Fig. 12

Q2 Menu

El menú Q2 contiene los ajustes de la salida de conmutación 2.

Objetivo	Submenú	Opción
Ajustar la salida de conmutación como salida de conmutación, frecuencia, impulso o analógico	Function	Ajustar la salida de conmutación como <i>Switch</i> , <i>Frequency</i> , <i>Pulse</i> o <i>Analog</i>
Ajustar el modo para la histéresis o la función de ventana	Mode	Ajustar el modo para la histéresis o la función de ventana
Ajustar el punto de conmutación	SetPoint1	Ajustar el punto de conmutación
Ajustar el punto de retroceso/ la histéresis o el límite inferior de la ventana	SetPoint2	Ajustar el punto de retroceso/ la histéresis o el límite inferior de la ventana
Ajustar el comportamiento de conmutación del contacto de reposo	Polarity	Elegir entre <i>NormallyClosed</i> y <i>NormallyOpen</i>
Simular la salida de conmutación	Simulate	Elegir entre <i>Active</i> , <i>Inactive</i> y <i>Normal</i> (medición)
Ajustar PNP/NPN o Push/Pull	DriverType	Ajustar <i>PNP/NPN</i> o <i>Push/Pull</i>

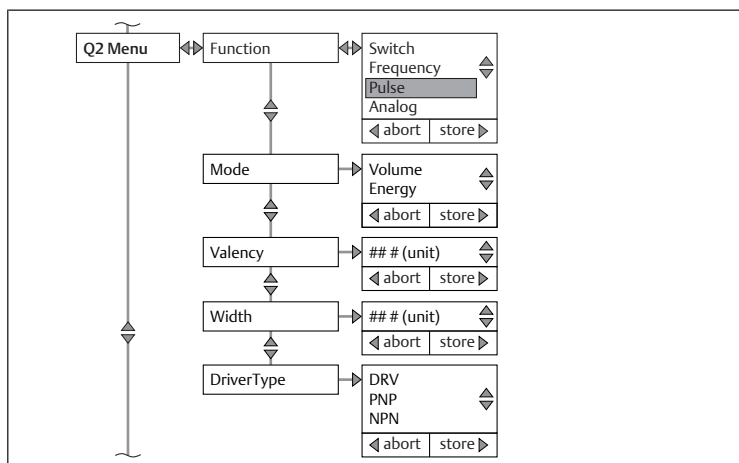

Fig. 15

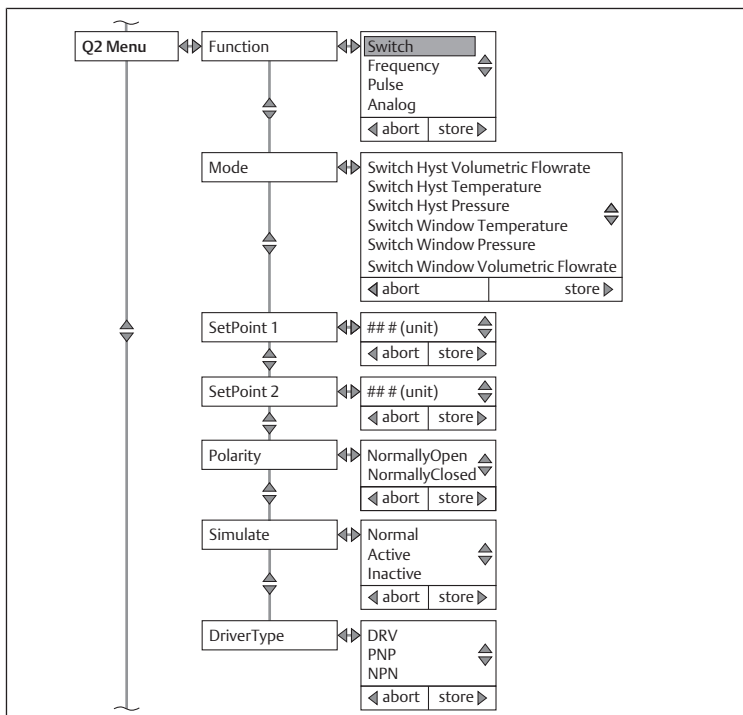

Fig. 13

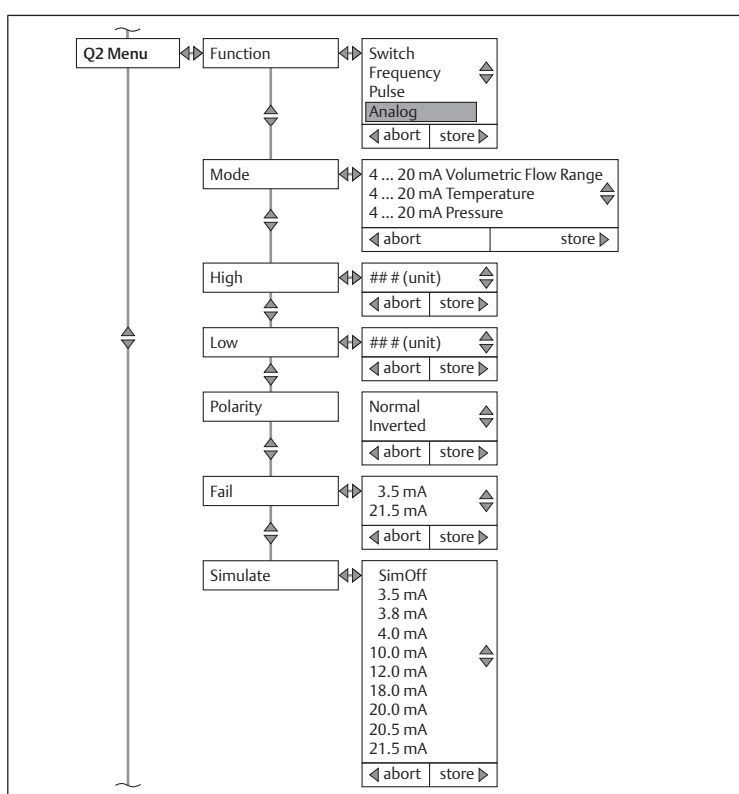

Fig. 16

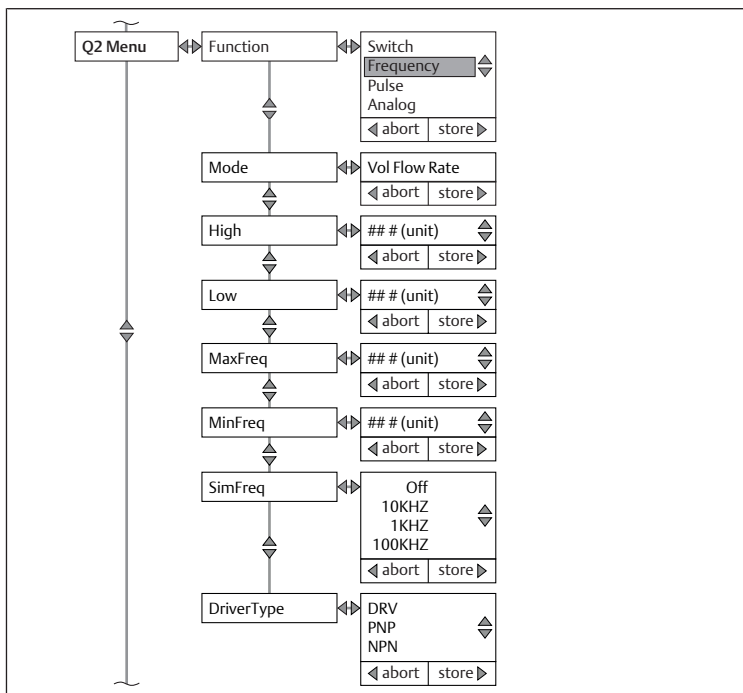

Fig. 14

Qa Menu

El menú Qa contiene los ajustes de la salida analógica.

Objetivo	Submenú	Opción
Asignar parámetros de medición a la salida de corriente	Mode	Asignar parámetros de medición como caudal, temperatura o presión a la salida de corriente
Asignar el valor final del margen de medición	High	Fijar el valor final del margen de medición a 20 mA
Asignar el inicio del margen de medición	Low	Fijar el inicio del margen de medición a 4 mA
Ajustar la inversión de la salida de corriente	Polarity	Ajustar la inversión de la salida de corriente
Ajustar el comportamiento de la salida de corriente en caso de fallo en el producto	Fail	Ajustar el comportamiento de la salida de corriente en caso de fallo en el producto
Ajustar el valor de corriente predefinido	Simulate	Ajustar el valor de corriente predefinido

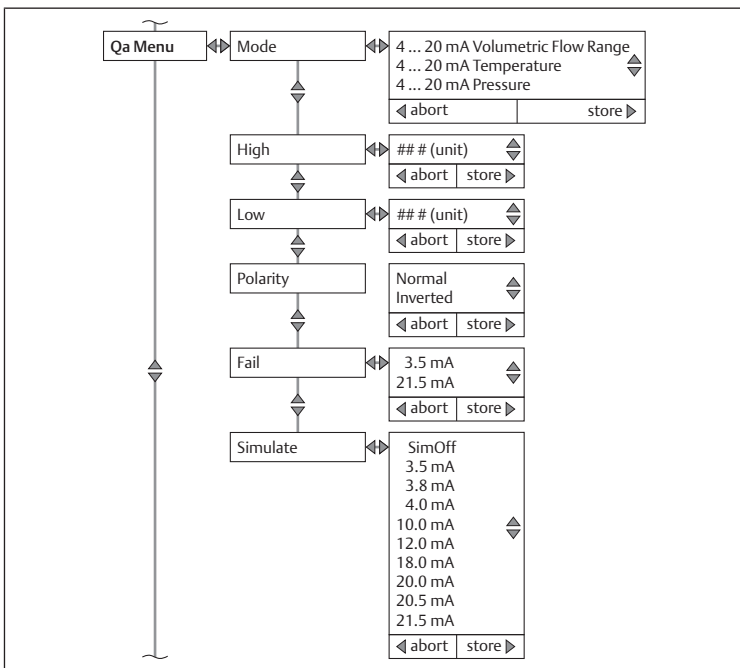

Fig. 17

3.2.3 Ajustes de la variante Ethernet

Los ajustes se aplican a todas las variantes del producto con la conexión eléctrica Ethernet.

Ethernet

Objetivo	Submenú	Opción
Asignar una dirección estática o dinámica	DHCP Mode	Asignar una dirección
Ajustar la dirección IP	IP Address	Ajustar la dirección IP
SubNetMask	SubNetMask	Ajustar SubNetMask
Gateway	Gateway	Ajustar la dirección de Gateway
Nombre	Nombre	Ajustar el nombre DHCP

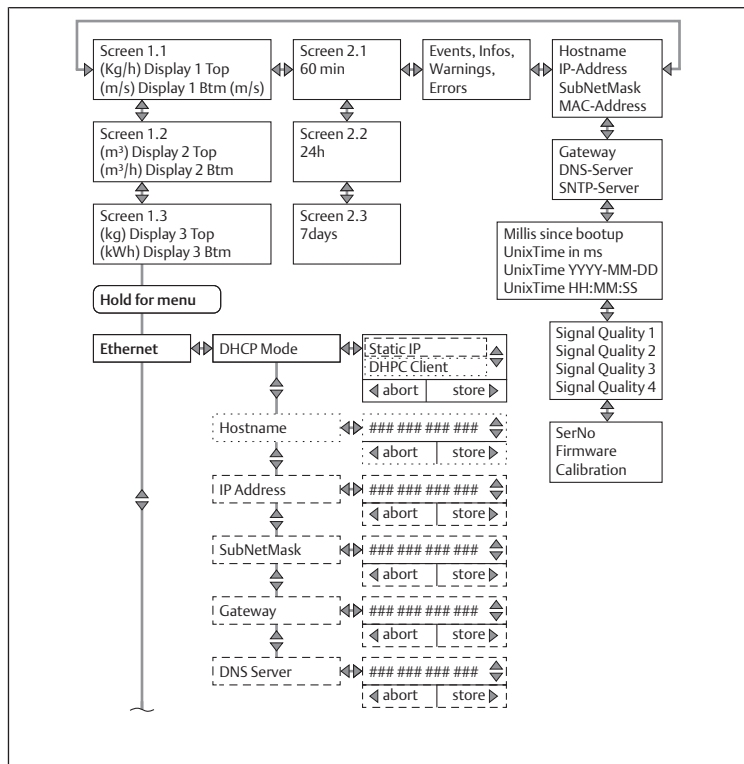
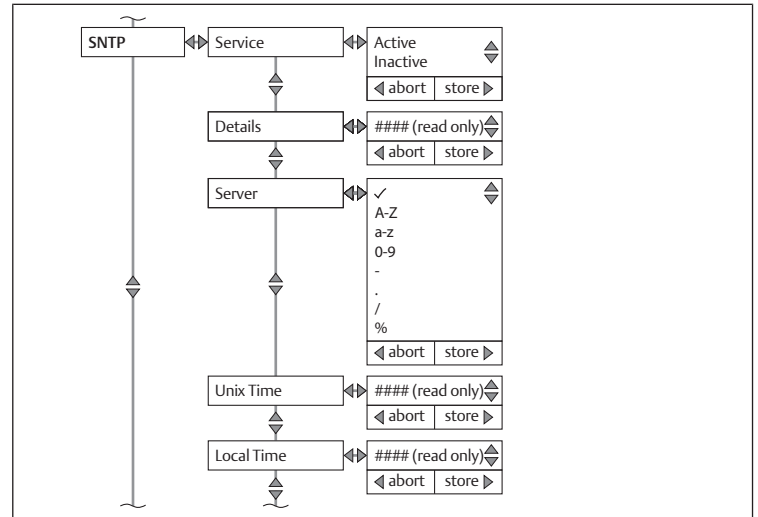

Fig. 18

SNTP



Webserver

Objetivo	Submenú	Opción
Conectar y desconectar la interfaz web	State	Elegir entre <i>Active</i> e <i>Inactive</i>
Ajustar el puerto	Port	Seleccionar el puerto del servidor web (Webserver). El puerto por defecto para el servicio HTTP es el puerto 80
Restablecer la contraseña del usuario	ResetPW	Restablecer la contraseña del servidor web para el usuario "Maintenance" al estado de entrega. La contraseña por defecto (ajuste de fábrica) es "airflowsensor"

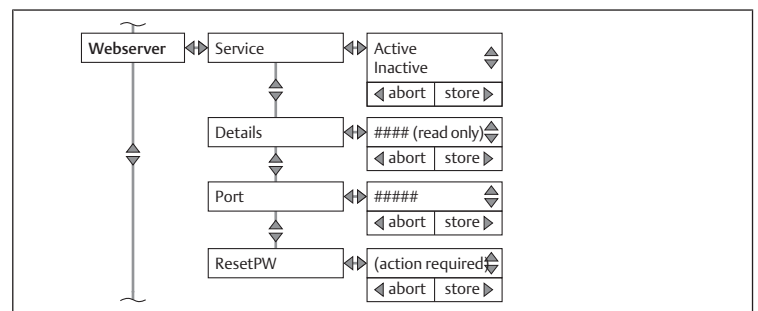

Fig. 19

OPCUA

Objetivo	Submenú	Opción
Conectar y desconectar la interfaz web	State	Elegir entre <i>Active</i> e <i>Inactive</i>
Ajustar el puerto	Port	Ajustar el puerto
Ajustar el nombre de usuario	User	Ajustar el nombre de usuario
Asignar una contraseña	Password	Ajustar la contraseña

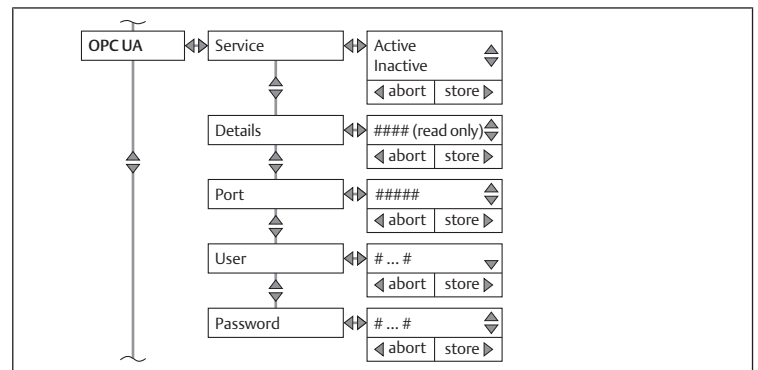

Fig. 20

MQTT

Objetivo	Submenú	Opción
Conectar y desconectar la interfaz web	State	Elegir entre <i>Active</i> e <i>Inactive</i>
Broker	Broker	Ajustar el broker
Ajustar el puerto	Port	Ajustar el puerto
Topic	Topic	Visualizar los Topics
User	User	Introducir el nombre de usuario para Broker
Crear la contraseña del Broker	Password	Introducir la contraseña del Broker
Enviar el intervalo de corte al Broker	Update	Fijar el intervalo de corte
QoS	QoS	Seleccionar <i>QoS-0</i> , <i>QoS-1</i> o <i>QoS-2</i>
Definir el mensaje MQTT en el Send Broker		Seleccionar la la opción de menú y ajustar <i>Active</i> o <i>Inactive</i>

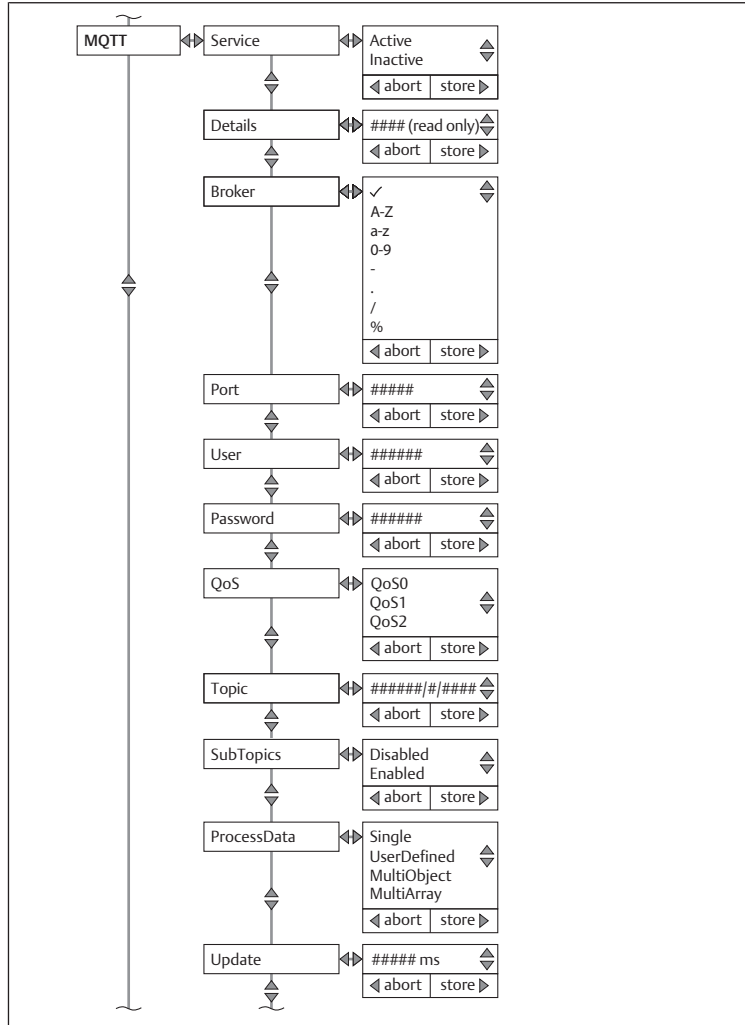

Fig. 21

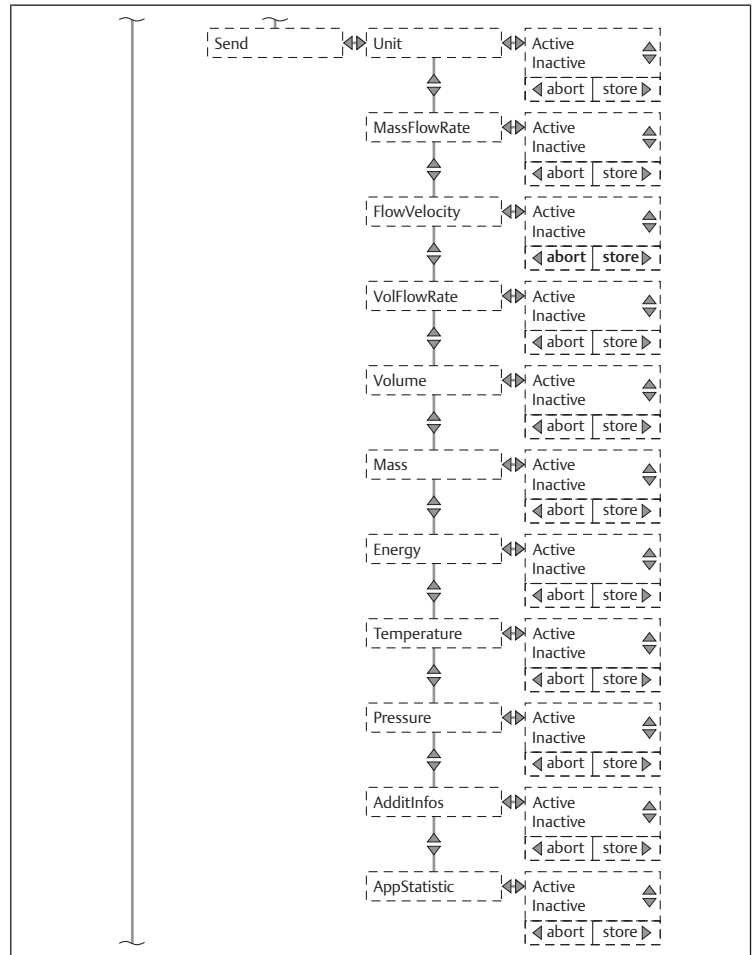

Fig. 22

Innehållsförteckning

1	Om denna dokumentation	44
1.1	Dokumentationens giltighet	44
1.2	Ytterligare dokumentation	44
1.3	Förkortningar som används	44
2	Säkerhet	44
2.1	Om detta kapitel	44
3	Data och parametrar	44
3.1	Säkerhetsinformation	44
3.2	Parameterdata	44
3.2.1	Allmänna inställningar	44
3.2.2	Inställningar för varianten IO-Link	47
3.2.3	Inställningar för varianten Ethernet	49

1 Om denna dokumentation

Dessa anvisningar innehåller viktig information för säker och korrekt hantering av produkten.

Den här dokumentationen är ett tillägg till de gällande monteringsanvisningarna. Läs monteringsanvisningarna fullständigt innan du arbetar med produkten.

1.1 Dokumentationens giltighet

Denna dokumentation riktar sig till:

Programmerare, servicepersonal, anläggningsansvariga

Den här dokumentationen innehåller kompletterande information om följande produktvarianter i serien AF2 och 652/653:

Serie	Produktvariant	Gränssnitt
AF2	Sensorfilterkombination (AS)	IO-Link Ethernet
	Sensor High Flow (HF)	IO-Link Ethernet
652	Filterproduktvariant	IO-Link (A) Ethernet (B)
	Rörproduktvariant	IO-Link (A) Ethernet (B)
653	Filterproduktvariant	IO-Link (A) Ethernet (B)
	Rörproduktvariant	IO-Link (A) Ethernet (B)

1.2 Ytterligare dokumentation

Beakta följande kompletterande dokumentation:

- Tillverkarens anläggningsdokumentation
- Dokumentation av övriga anläggningskomponenter
- Monteringsanvisning (R412026496 eller 549411)

1.3 Förkortningar som används

I denna dokumentation används följande förkortningar:

Förkortning	Innebörd
ABS	Akrylnitril-butadien-styrol
GF	Glasfiber
HF	High Flow
MBE	Slutvärde för mätområde
MQTT	Message Queuing Telemetry Transport
MTTF	Mean Time To Failure (medelarbetsstid till fel)
NPT	National Taper Pipe (typ av rörgänga)
OLED	Organic Light Emitting Diode (organisk lysdiod)
OPC UA	Open Platform Communications Unified Architecture
PA	Polyamid
PC	Polykarbonat
PSA	Personlig skyddsutrustning
Pt	Platina-mätmotstånd

2 Säkerhet

2.1 Om detta kapitel

- Läs kapitlet Säkerhet i monteringsanvisningen och hela dokumentationen noggrant innan du arbetar med produkten.
- Förvara dokumentation på en plats där den är tillgänglig för alla användare.

3 Data och parametrar

3.1 Säkerhetsinformation

- Utför inga parameterändringar under pågående drift (skadeförebyggande).

3.2 Parameterdata

3.2.1 Allmänna inställningar

Parameterinställningarna i detta avsnitt gäller för alla varianter av produkten.

Allmänt

Mål	Meny	Alternativ
Göra inställningar	Standardindikering	Håll valfri pilknapp intryckt i minst 2 sekunder och gör inställningarna i respektive meny.

Display

Mål	Undermeny	Alternativ
Ställa in enheter	Units	Välja mellan dessa menyer: <ul style="list-style-type: none"> MassFlowRate FlowVelocity Volume VolFlowRate Mass Energy Temperature Pressure
Ställa in indikering skärm 1.1	Pages	<ul style="list-style-type: none"> Välja Disp1Top Välja Disp1Btm
Ställa in indikering skärm 1.2	Pages	<ul style="list-style-type: none"> Välja Disp2Top Välja Disp2Btm
Ställa in indikering skärm 1.3	Pages	<ul style="list-style-type: none"> Välja Disp3Top Välja Disp3Btm
Ställa in indikering skärm 2.1, 2.2 och 2.3	Pages	Välja indikeringsparametrar i menyn DispHistory
Optimera läsbarhet	Rotation	Ställa in indikering 0°, 90°, 180° eller 270°
Aktivera skärmsläckare	ScreenSaver	Ställa in tid för aktivering av skärmsläckaren
Stänga av display	AutoOff	Ställa in tid för avstängning av displayen
Ställa in ljusstyrka	Brightness	Ställa in ljusstyrka i procent
Tilldela pinkod för manöver-resp. manipulationsskydd	Display Pin	Tilldela en 4-siffrig pinkod



Bild 1



Bild 2

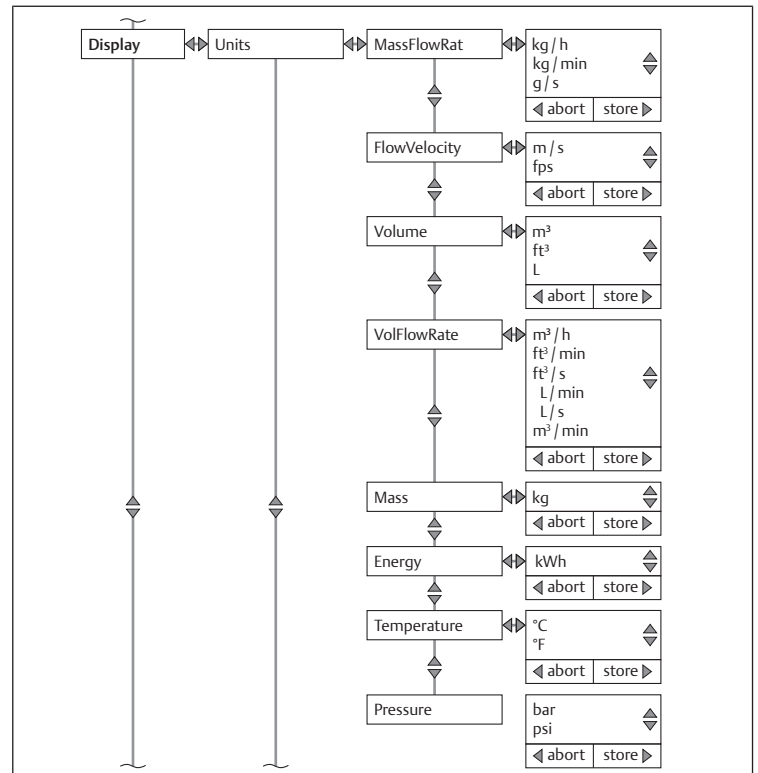

Bild 3

Simulate

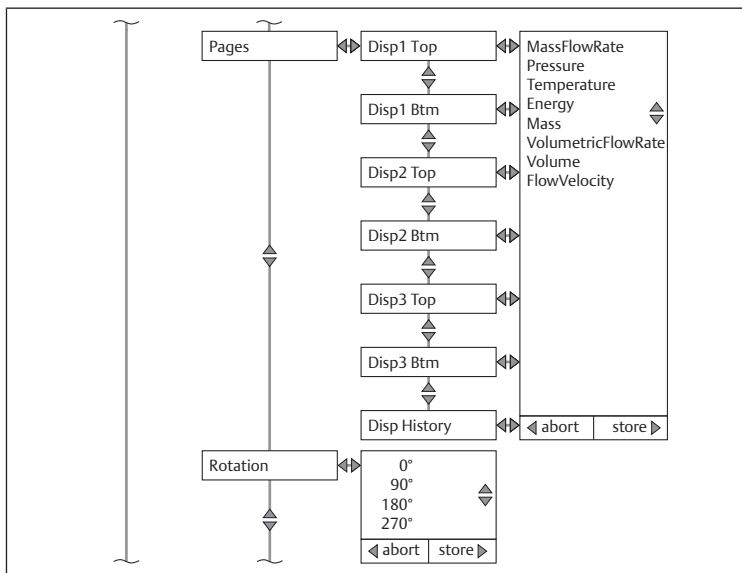
Mål	Undermeny	Alternativ
Simulera flöde	Flow	Simulera flöde
Simulera temperatur	Temperature	Simulera temperatur
Simulera tryck	Pressure	Simulera tryck

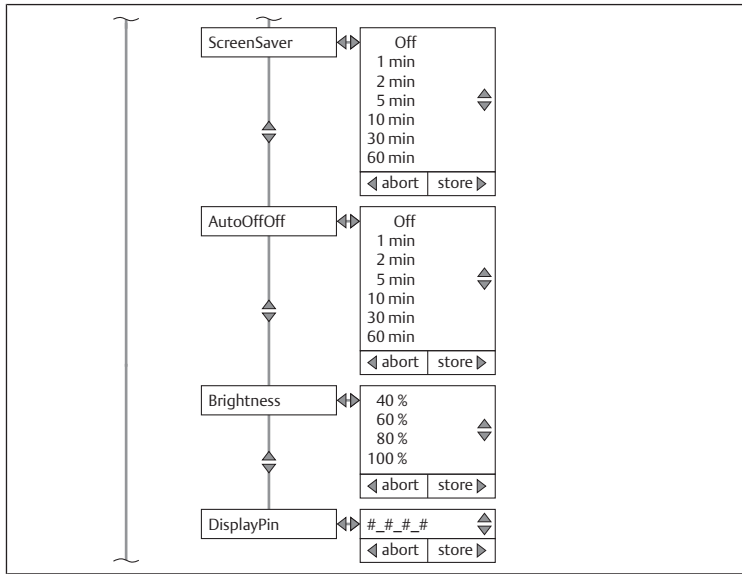

Bild 4

Measure

Mål	Undermeny	Alternativ
Ställa in mätmedium	Flow	Välja alternativet <i>Medium</i> och ställa in mätmediet: <ul style="list-style-type: none"> Air Argon CO2 Nitrogen

Mål	Undermeny	Alternativ
Ställa in referensnorm/ referensstandard	Flow	Välja alternativet <i>RefCond</i> och ställa in referensnorm/ referensstandard: <ul style="list-style-type: none"> ISO 2533 ISO 1217 DIN 1945-1 DIN 1343 ISO 6358 ISO 8778 UserDefined (användarspecifikt)
Ställa in referenstryck med användarspecifik inställning (UserDefined)	Flow	Välja alternativet <i>RefCond</i> och välja UserDefined (användarspecifikt referenstryck)
Ställa in nollpunktsförskjutning	Flow	Välja alternativet <i>0-FlowOff</i> och ställa in nollpunktsförskjutningen
Ställa in undertryckning av smyg mängd	Flow	Välja alternativet <i>0-FlowCut</i> och ställa in undertryckning av smyg mängd
Medelvärdesfilter för utjämning av mätvärde i indikering och utgång	Flow/Pressure/Temperature	Välja alternativet <i>Filter</i> och ställa in mätvärdesfiltret
Ställa in offset/ nollpunktsförskjutning	Pressure/Temperature	Välja <i>Offset</i> och ställa in offset/nollpunktsförskjutning
Välja signalkvalitet	SigQuality	Välj mellan <i>SigQua1</i> , <i>SigQua2</i> , <i>SigQua3</i> och <i>SigQua4</i> . Kvaliteten är alltid inställd på 100 %. Signalkvalitet 1 är ett mått på robusthet

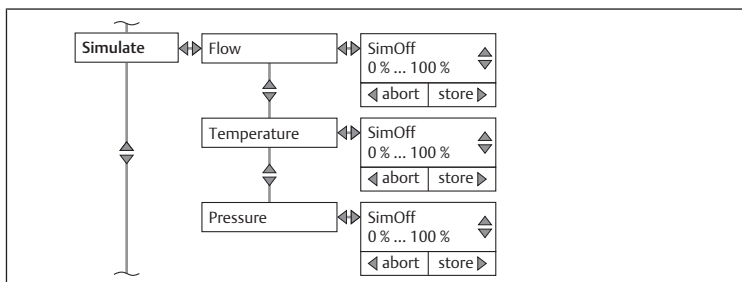

Bild 5



Bild 6

History

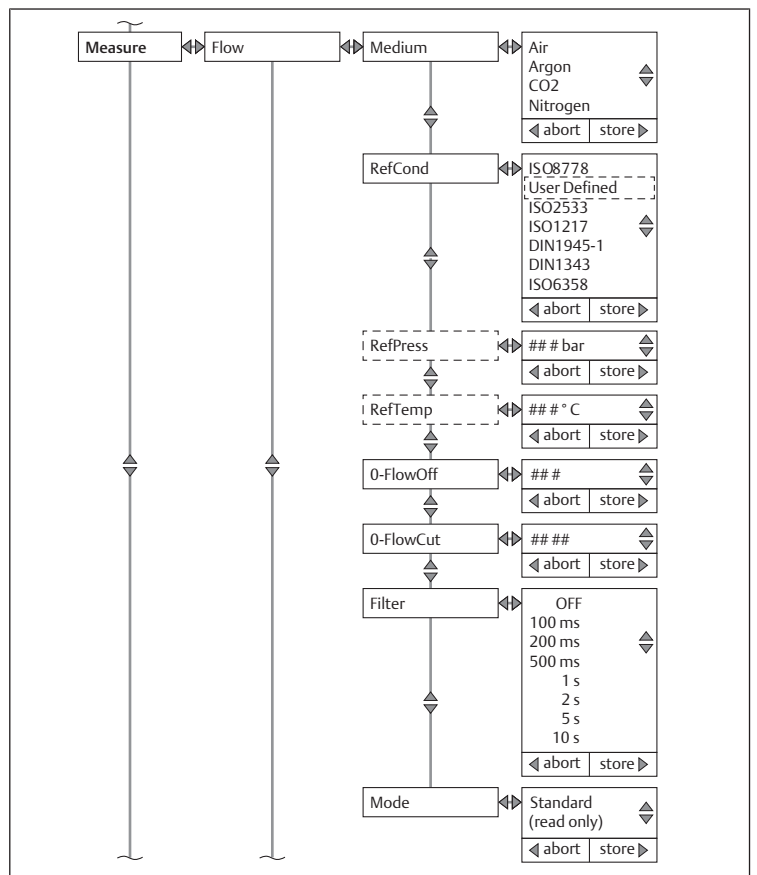
Mål	Undermeny	Alternativ
Välja indikering/kurva för mätvärdena de senaste 60 minuterna	60 min	Välja indikeringen/kurvan för mätvärdena de senaste 60 minuterna
Välja indikering/kurva för mätvärdena de senaste 24 timmarna	24 hour	Välja indikeringen/kurvan för mätvärdena de senaste 24 timmarna
Välja indikering/kurva för mätvärdena de senaste 7 dagarna	7 days	Välja indikeringen/kurvan för mätvärdena de senaste 7 dagarna

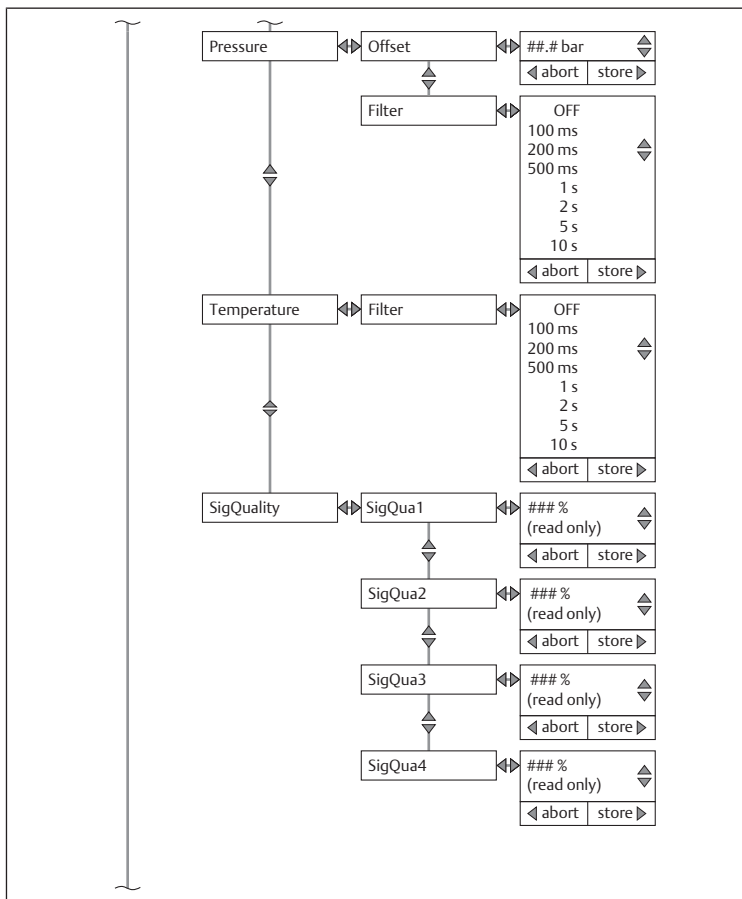

Bild 7

Statistics

Mål	Undermeny	Alternativ
Minimivärden, medelvärden och maxvärden för enskilda parametrar efter senaste återställningen	View	Visa <i>Max, mean, min values</i> för enskilda parametrar efter senaste återställningen
Visa tidpunkt för senast återställningen (read only)	LastReset	Visa tidpunkten för senast återställningen
Återställa statistikvärden till 0	Reset	Återställa statistikvärden till 0

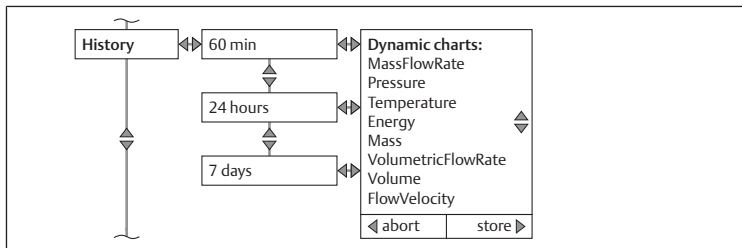

Bild 8

Counter

Mål	Undermeny	Alternativ
Visa räknare		Välja mellan undermenyerna <i>Mass, Volume, Energy</i> och <i>LastReset</i> och visa räknare
Återställa räknare	Reset	Återställa räknare

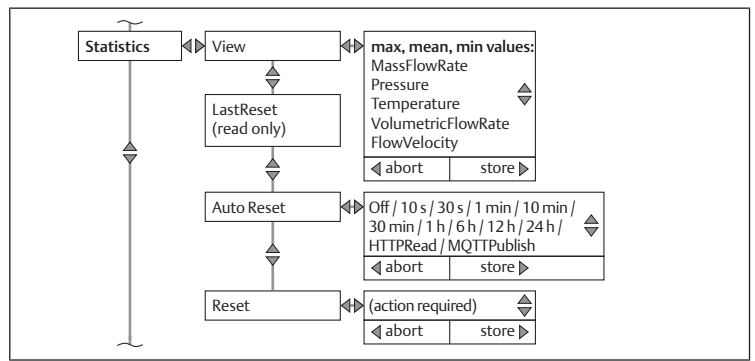

Bild 9

System

Mål	Undermeny	Alternativ
Service-inloggning	Service	Service-inloggning för auktoriserade användare
Återställa till fabriksinställning	FactReset	Återställa systemet till fabriksinställning
Serial Number (read only)	SerialNumber	Visa materialnummer
Ställa in enhetstag	DevTag	Ställa in enhetstag
Ställa in Application-tag	AppTag	Ställa in Application-tag
FWVersion (read only)	FWVersion	Visa firmwareversion
Calibration (read only)	Calibration	Visa firmware-defaults
BLVersion (read only)	BLVersion	Visa bootloadversion
HWVersion (read only)	HWVersion	Visa hårdvaruversion

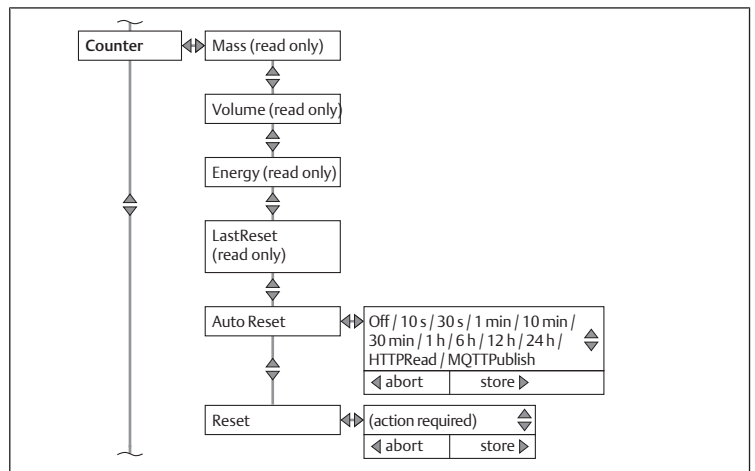

Bild 10

Tags

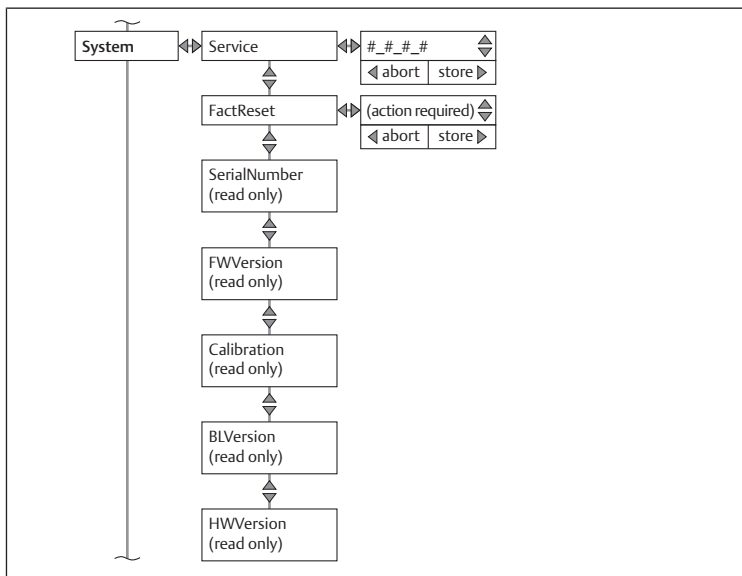

Bild 11

3.2.2 Inställningar för varianten IO-Link

Inställningarna gäller för alla varianter av produkten med den elektriska anslutningen IO-Link.

IO-Link

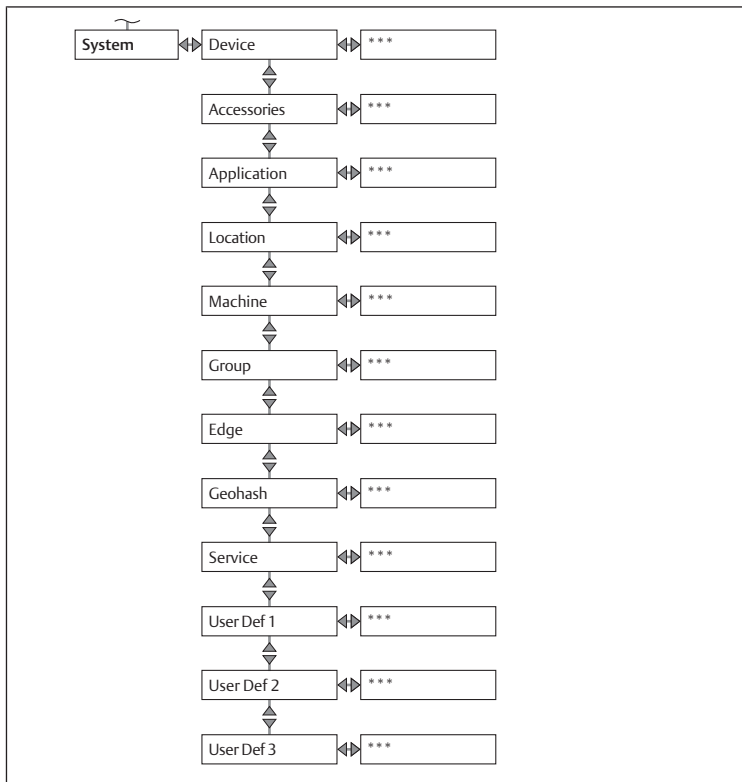
Displayen visar mätvärdesmenyn med standardinställningen (kg/h, m/s).

Mål	Meny	Alternativ
Välja meny	Standardindikering	Håll valfri pilknapp intryckt i minst 2 sekunder och välj mellan <i>Q1 Menu</i> , <i>Q2 Menu</i> och <i>Qa Menu</i> .
Ställa in kopplingsutgång	Q1 Menu	Ställa in kopplingsutgång
Ställa in kopplingsutgång	Q2 Menu	Ställa in kopplingsutgång
Ställa in analog utgång	Qa Menu	Ställa in analog utgång

Q1 Menu

Q1-menyn innehåller inställningarna för kopplingsutgång 1.

Mål	Undermeny	Alternativ
Ställa in hysteres eller fönsterfunktion	Mode	Ställa in läge för hysteres eller fönsterfunktion med tillhörande mätparametrar
Ställa in inkopplingsläge	SetPoint1	Ställa in inkopplingsläge
Ställa in återställningsläge/ hysteres resp. undre fönstergräns	SetPoint2	Ställa in återställningsläge/ hysteres resp. undre fönstergräns
Ställa in kopplingsbeteende för öppnande kontakt	Polarity	Välja mellan <i>NormallyClosed</i> och <i>NormallyOpen</i>
Simulera kopplingsutgång	Simulate	Välj mellan <i>Active</i> , <i>Inactive</i> eller <i>Normal</i> (mätområde)
Ställa in PNP/NPN eller Push/ Pull (DRV)	DriverType	Ställa in <i>PNP/NPN</i> eller <i>Push/ Pull (DRV)</i>



Bild 12

Q2 Menu

Q2-menyn innehåller inställningarna för kopplingsutgång 2.

Mål	Undermeny	Alternativ
Ställa in kopplingsutgång som kopplingsutgång, frekvens, puls eller analog	Function	Ställa in kopplingsutgången som <i>Switch</i> , <i>Frequency</i> , <i>Pulse</i> eller <i>Analog</i>
Ställa in läge för hysteres eller fönsterfunktion	Mode	Ställa in läge för hysteres eller fönsterfunktion
Ställa in inkopplingsläge	SetPoint1	Ställa in inkopplingsläge
Ställa in återställningsläge/ hysteres resp. undre fönstergräns	SetPoint2	Ställa in återställningsläge/ hysteres resp. undre fönstergräns
Ställa in kopplingsbeteende för öppnande kontakt	Polarity	Välja mellan <i>NormallyClosed</i> och <i>NormallyOpen</i>
Simulera kopplingsutgång	Simulate	Välja mellan <i>Active</i> , <i>Inactive</i> och <i>Normal</i> (mätområde)
Ställa in PNP/NPN eller Push/ Pull	DriverType	Ställa in <i>PNP/NPN</i> eller <i>Push/ Pull</i>

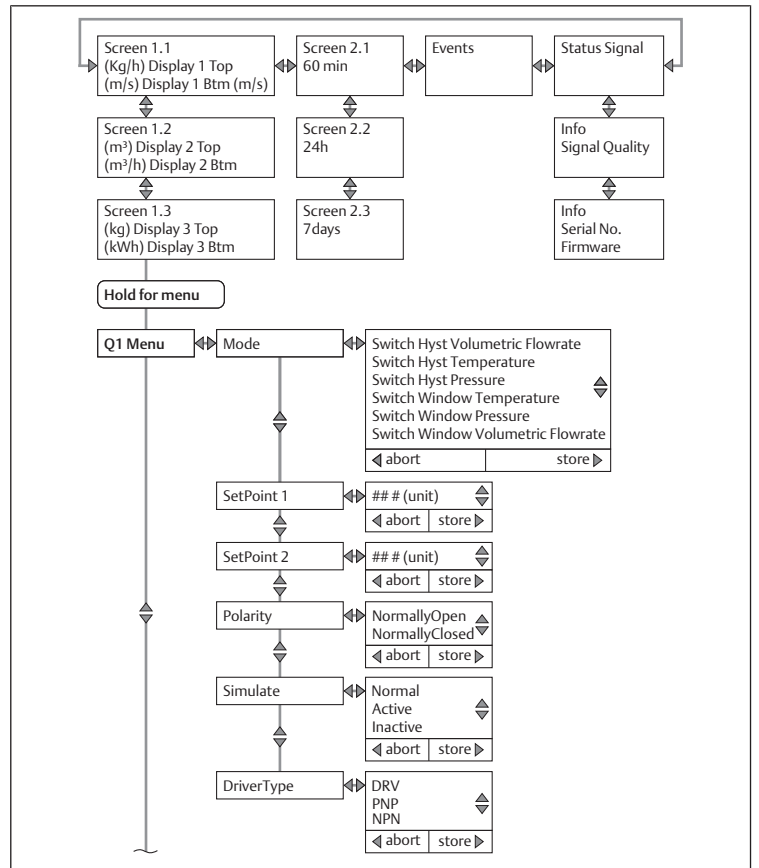

Bild 13



Bild 16

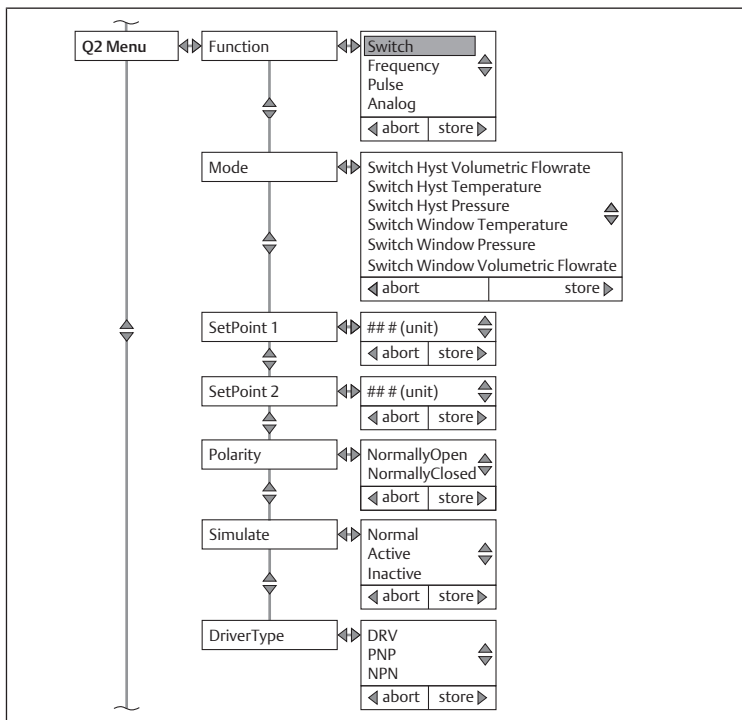

Bild 14

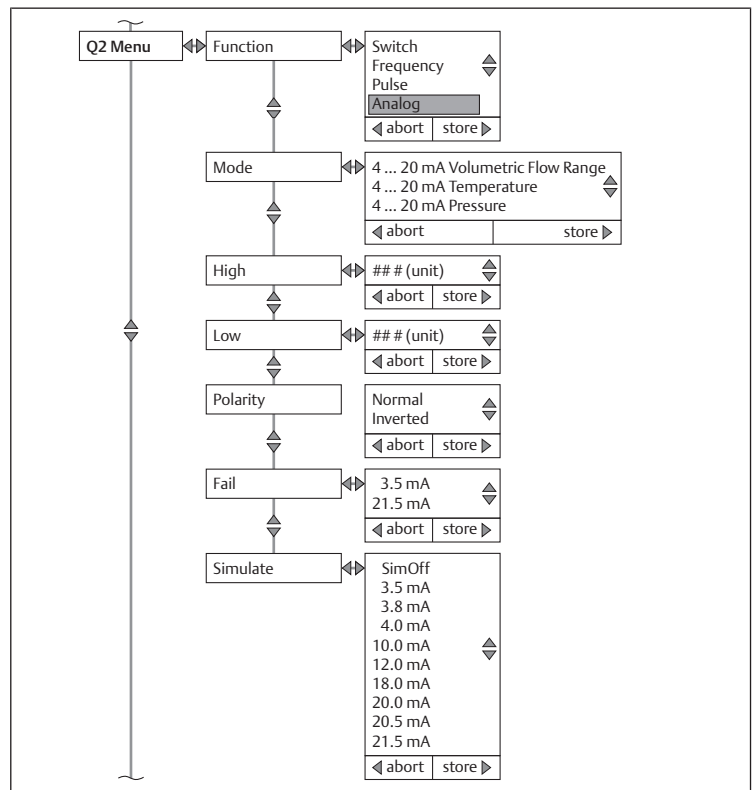

Bild 15

Qa Menu

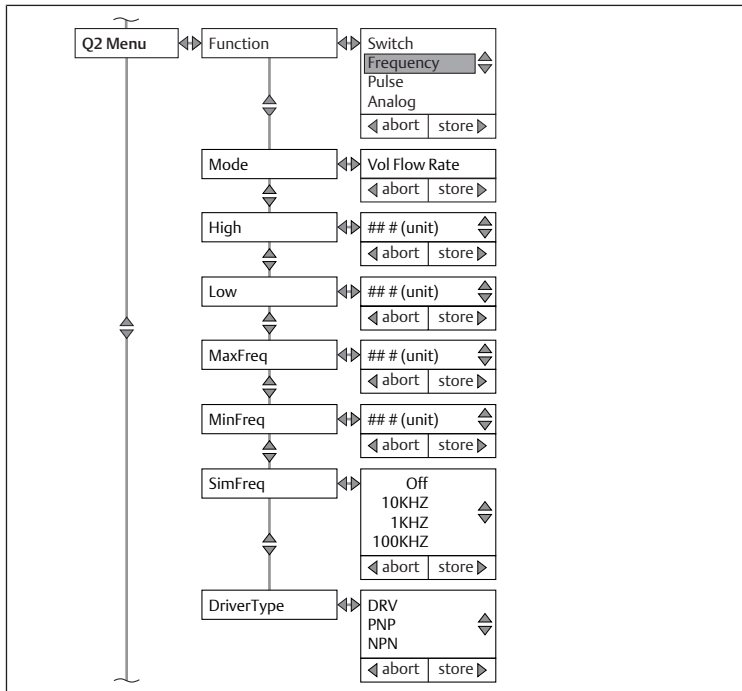
Qa-menyn innehåller inställningarna för den analoga utgången.

Mål	Undermeny	Alternativ
Tilldela mätparametrar ström utgång	Mode	Tilldela mätparametrar som flöde, temperatur eller tryck till ström utgången
Tilldela slutvärde för mätområde	High	Ställa in slutvärdet för mätområdet på 20 mA
Tilldela mätområdets början	Low	Ställa in mätområdets början på 4 mA
Ställa in invertering av ström utgång	Polarity	Ställa in invertering av ström utgång
Ställa in spänningsutgångens reaktion vid ett fel i produkten	Fail	Ställa in spänningsutgångens reaktion vid ett fel i produkten
Ställa in fördefinierat ström värde	Simulate	Ställa in fördefinierat ström värde

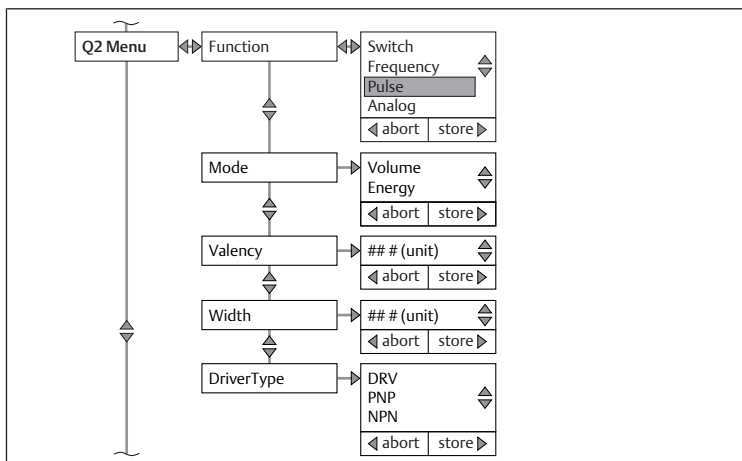

Bild 17

3.2.3 Inställningar för varianten Ethernet

Inställningarna gäller för alla varianter av produkten med den elektriska Ethernet-anslutningen.

Ethernet

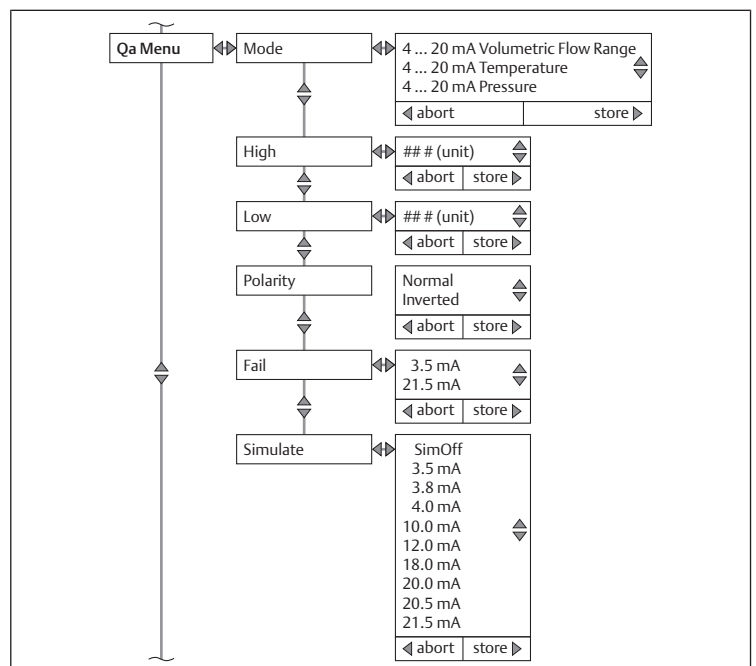
Mål	Undermeny	Alternativ
Tilldela statisk eller dynamisk adress	DHCP Mode	Tilldela adress
Ställa in IP-adress	IP Address	Ställa in IP-adress
Subnätmask	SubNetMask	Ställa in subnätmask
Gateway	Gateway	Ställa in gatewayadress
Name	Name	Ställ in DHCP-namnet



Bild 18

SNTP

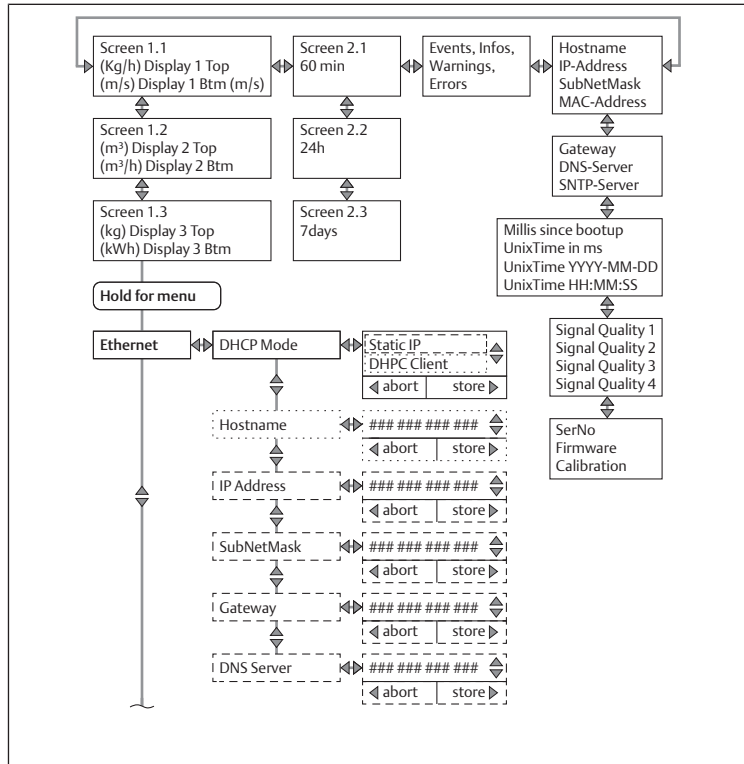
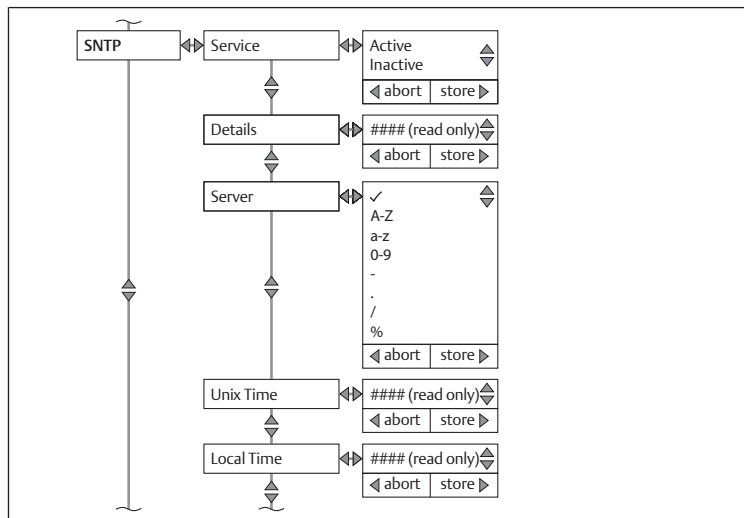

Webbserver

Mål	Undermeny	Alternativ
Koppla in och stänga av webbgränssnitt	State	Välja mellan Active och Inactive
Ställa in port	Port	Välj webbserver-porten. Standardporten för HTTP-tjänsten är port 80

Mål	Undermeny	Alternativ
Återställa lösenord på användarsidan	ResetPW	Återställ webbserverlösenordet för användaren "Maintenance" till leveransstatusen. Standardlösenordet (fabriksinställning) är "airflowsensor"



Bild 19

OPC UA

Mål	Undermeny	Alternativ
Koppla in och stänga av webbgränssnitt	State	Välja mellan Active och Inactive
Ställa in port	Port	Ställa in port
Ställa in användarnamn	User	Ställa in användarnamnen
Tilldela lösenord	Password	Ställa in lösenordet

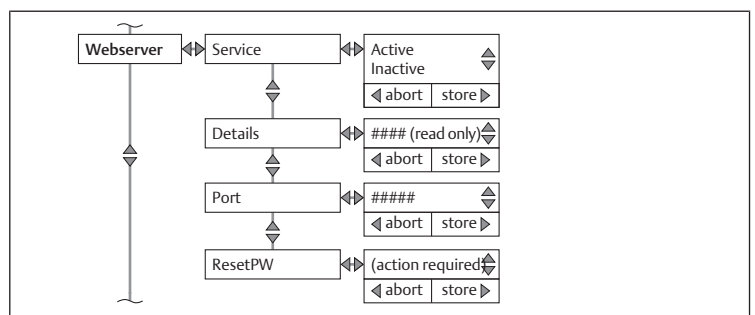

Bild 20

MQTT

Mål	Undermeny	Alternativ
Koppla in och stänga av webbgränssnitt	State	Välja mellan Active och Inactive
Koordinator	Broker	Ställ in koordinator
Ställa in port	Port	Ställa in port
Ämne	Topic	Visa ämnen
Användare	User	Ange användarnamn för koordinator
Ställa in koordinator-lösenord	Password	Ange lösenord för koordinator
Sända justeringsintervall till koordinator	Update	Registrera justeringsintervall
QoS	QoS	Välja QoS-0 , QoS-1 eller QoS-2
Definiera MQTT-meddelande till koordinator	Send	Välja meny punkten i andra undermenyn och ställa in Active eller Inactive

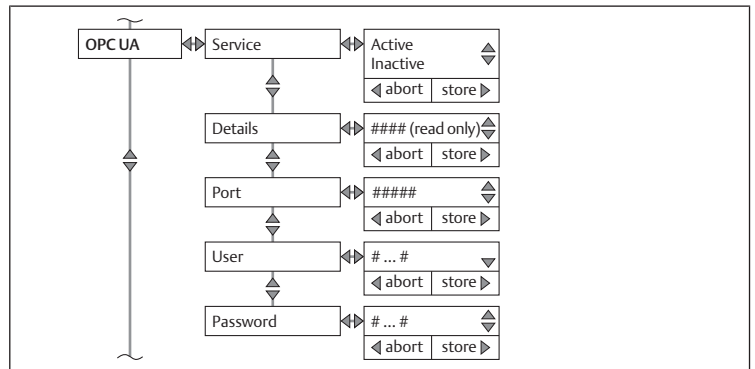

Bild 21



Bild 22

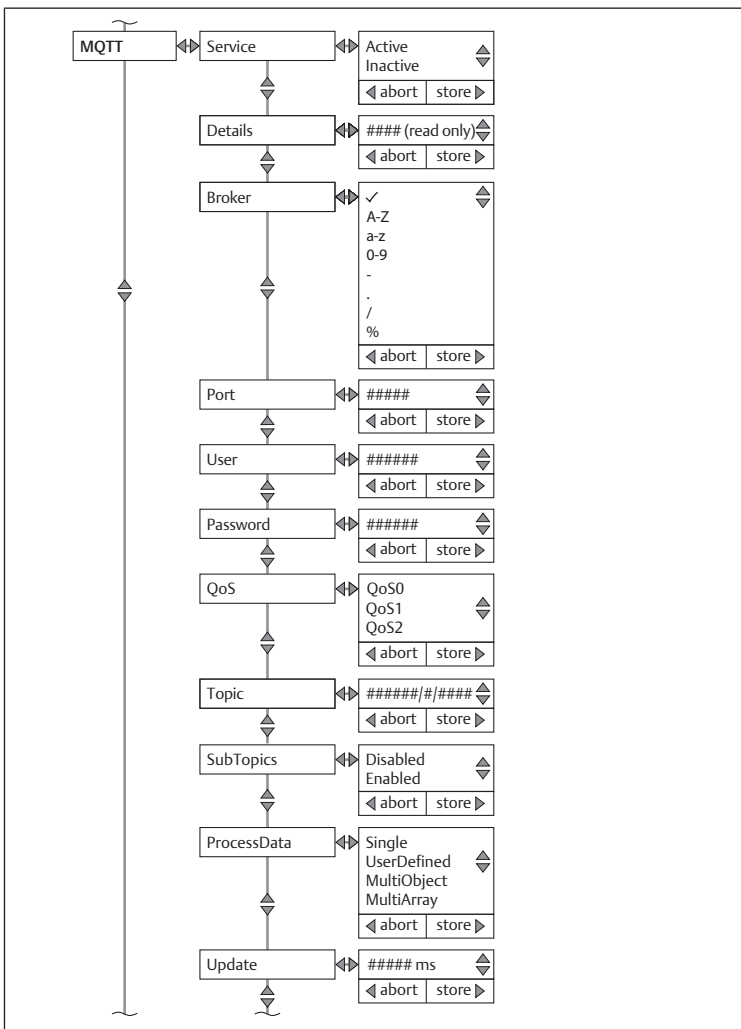

Import into the United Kingdom is done by:

**Emerson Automation
Fluid Control & Pneumatics UK Ltd**
2 Pit Hey Place, West Pimbo
Skelmersdale | WN8 9PG
United Kingdom

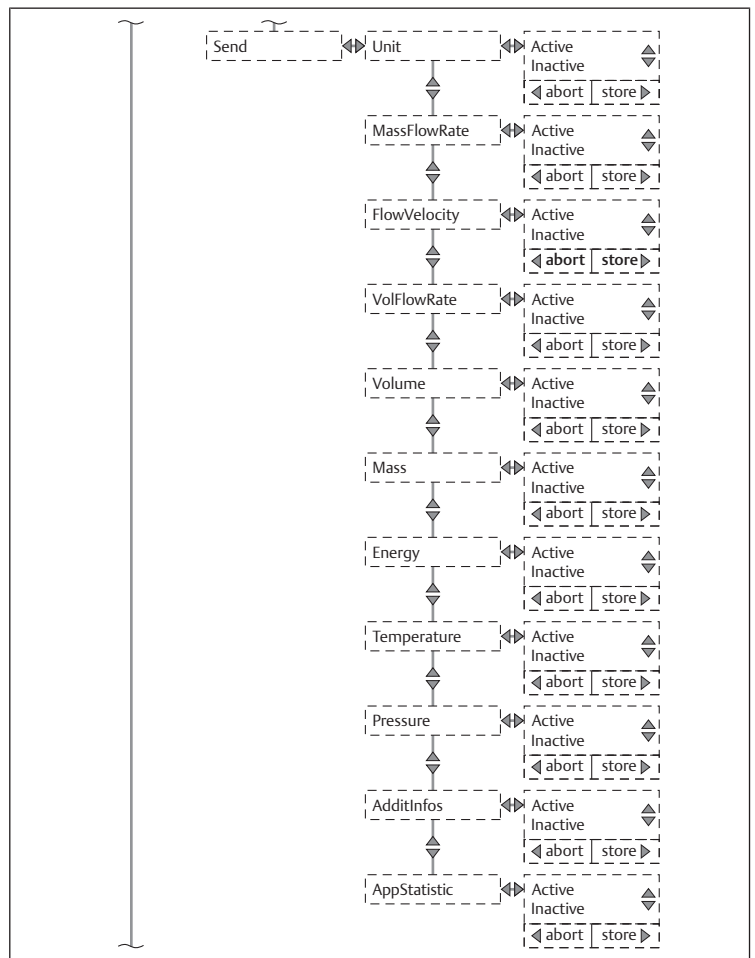
Emerson Automation Solutions

AVENTICS GmbH
Ulmer Straße 4
30880 Laatzen, GERMANY
phone +49 511 2136-0
fax +49 511 2136-269
www.emerson.com/aventics
aventics@emerson.com

Further addresses:
www.emerson.com/contactus

The data specified above only serve to describe the product. No statements concerning a certain condition or suitability for a certain application can be derived from our information. The given information does not release the user from the obligation of own judgement and verification. It must be remembered that our products are subject to a natural process of wear and aging.

An example configuration is depicted on the title page. The delivered product may thus vary from that in the illustration.

Translation of the original operating instructions. The original operating instructions were created in the German language.

Subject to modifications. © All rights reserved by AVENTICS GmbH, even and especially in cases of proprietary rights applications. This document may not be reproduced or given to third parties without our consent.

The Emerson logo is a trademark and service mark of Emerson Electric Co. AVENTICS is a mark of one of the Emerson Automation Solutions family of business units. All other marks are property of their respective owners.

