

REVISIONS						
ZONE	REV	DESCRIPTION	DATE	ECN/ECO	DRAWN	APPR.
GH9	01	DIMENSIONS 7.12 WAS 6.87 AND 7.43 WAS 7.18	10/24/13	20332	CRS	JVL
C4-C5, G6-H8	02	UPDATED TO SHOW THE CHANGES OF BOTTOM BRACKET; ADDED DIMENSION 5.53 & .27; ADDED 4X TO DIMENSIONS .13 & .31; CORRECTED MINOR DETAILS.	2/7/2018	22264	AAMG	JVL
ALL	03	UPDATED PER IMPACT ANALYSIS	01/13/202	104476	JCN	HTR

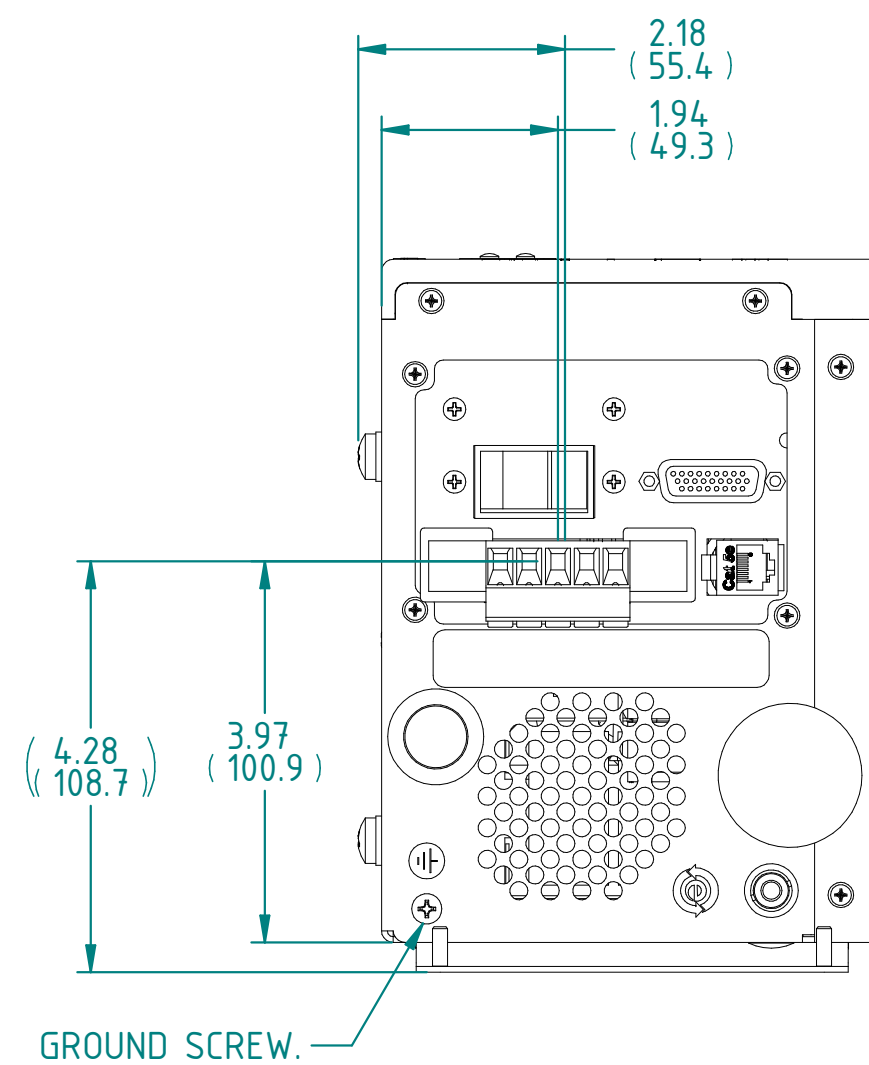
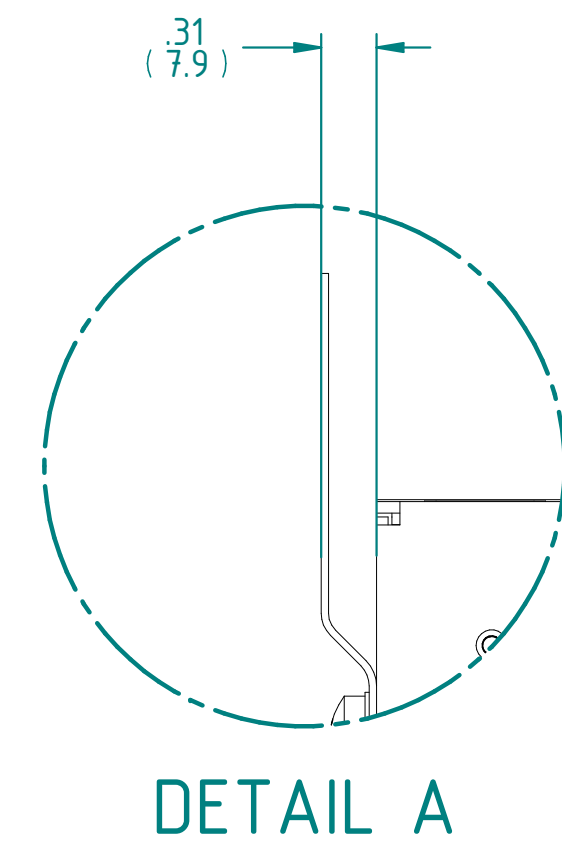
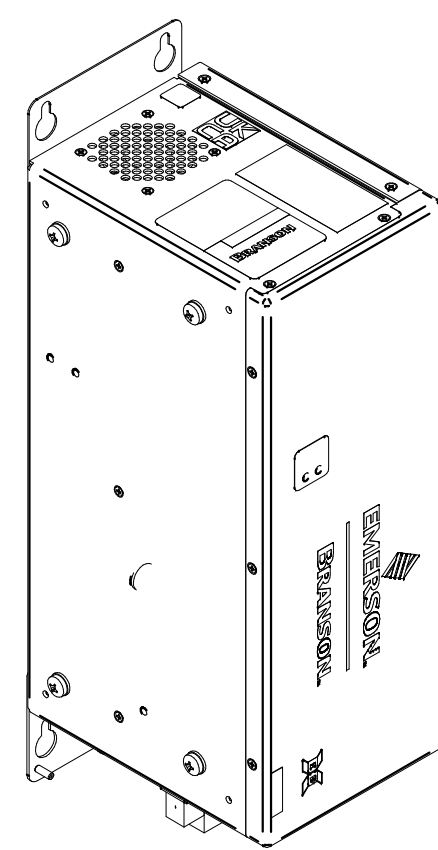
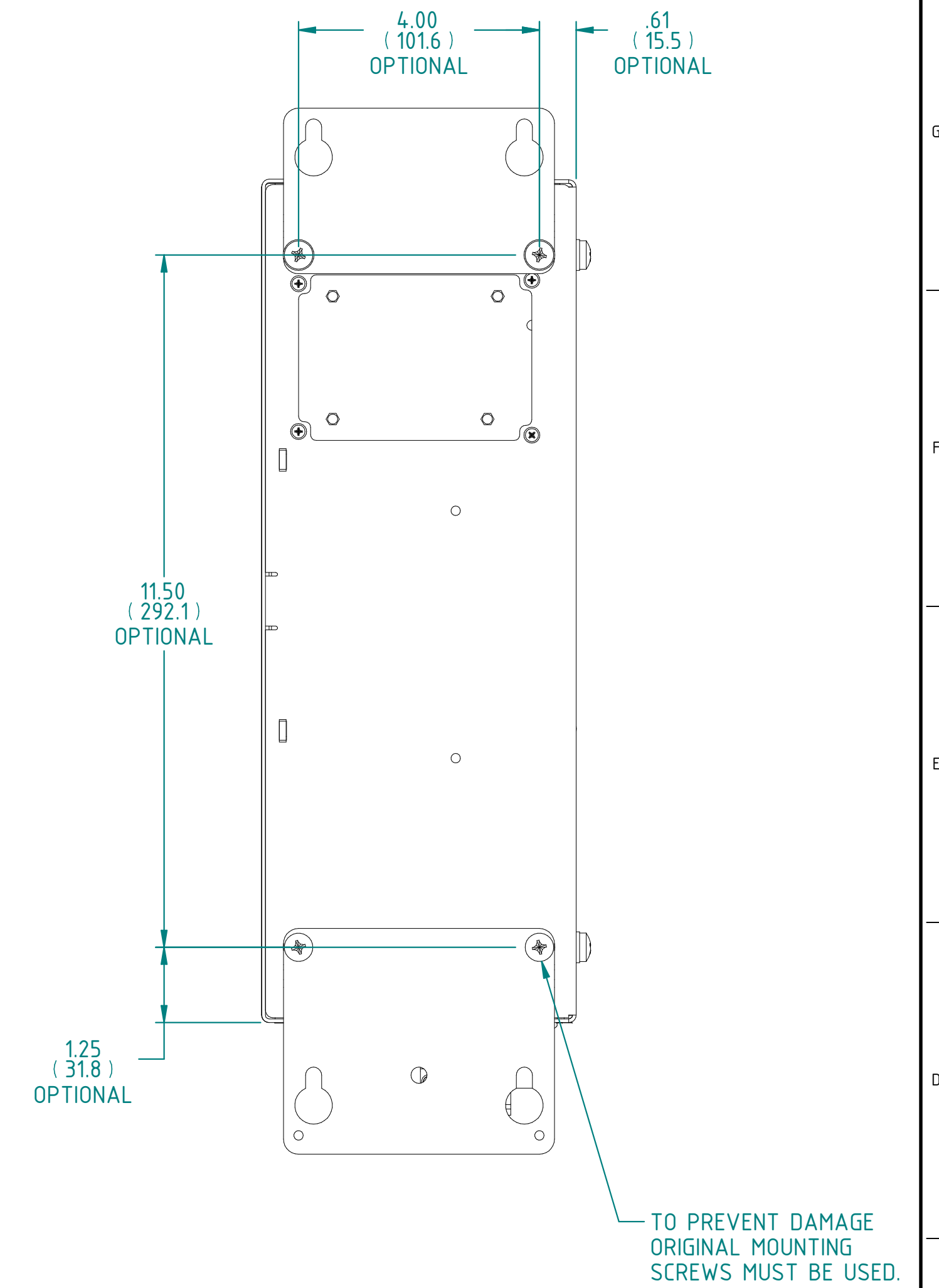
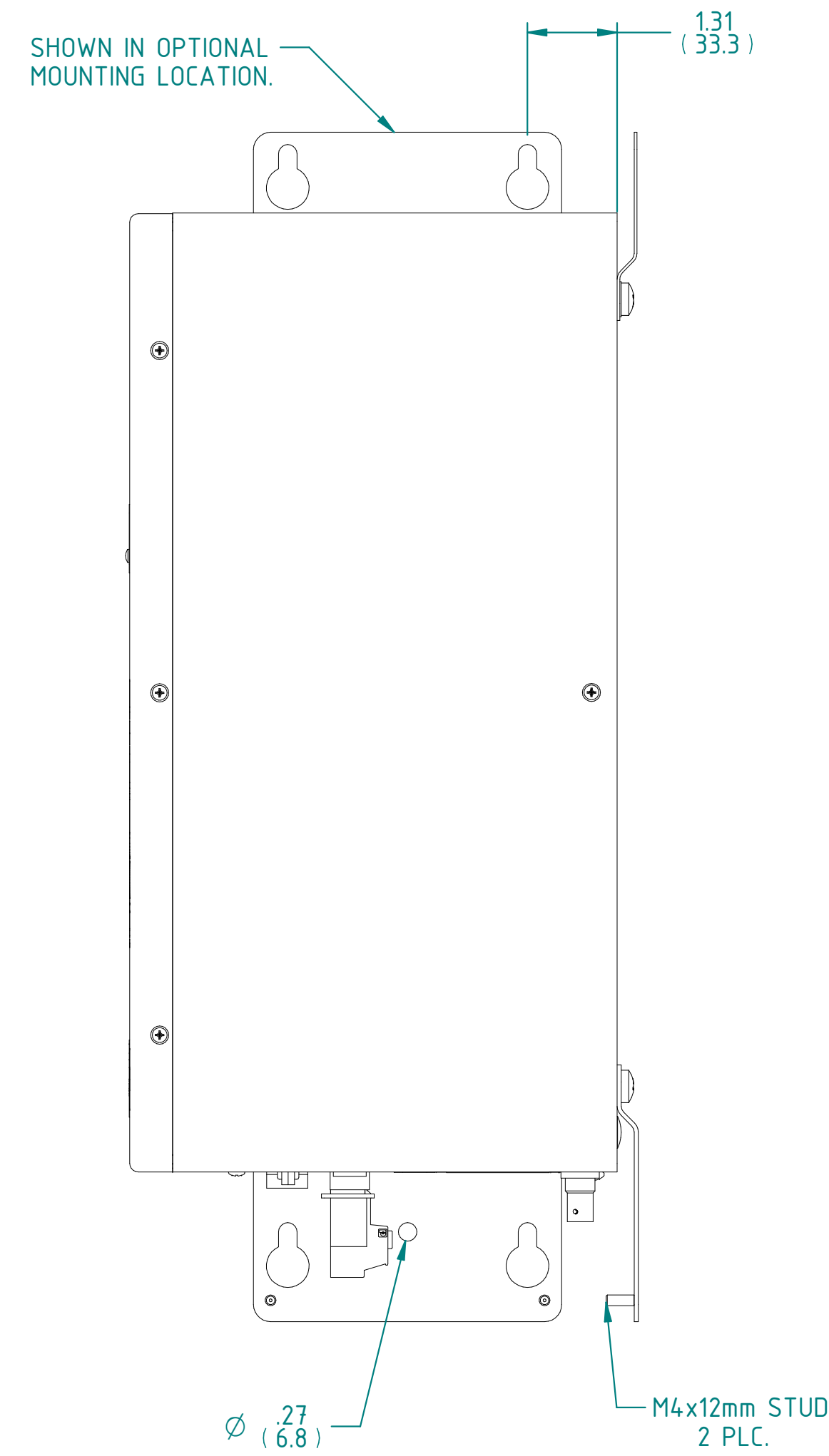
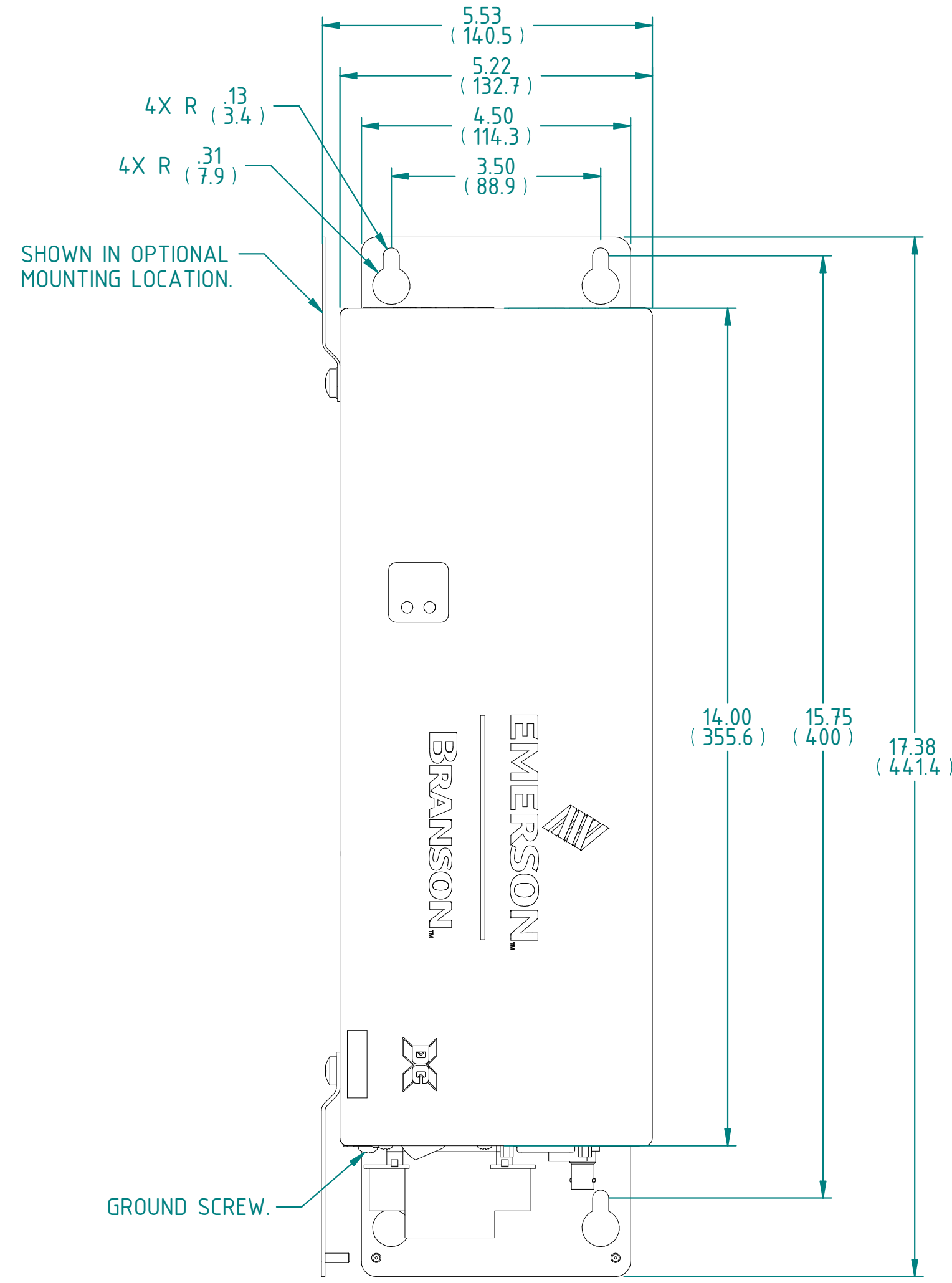
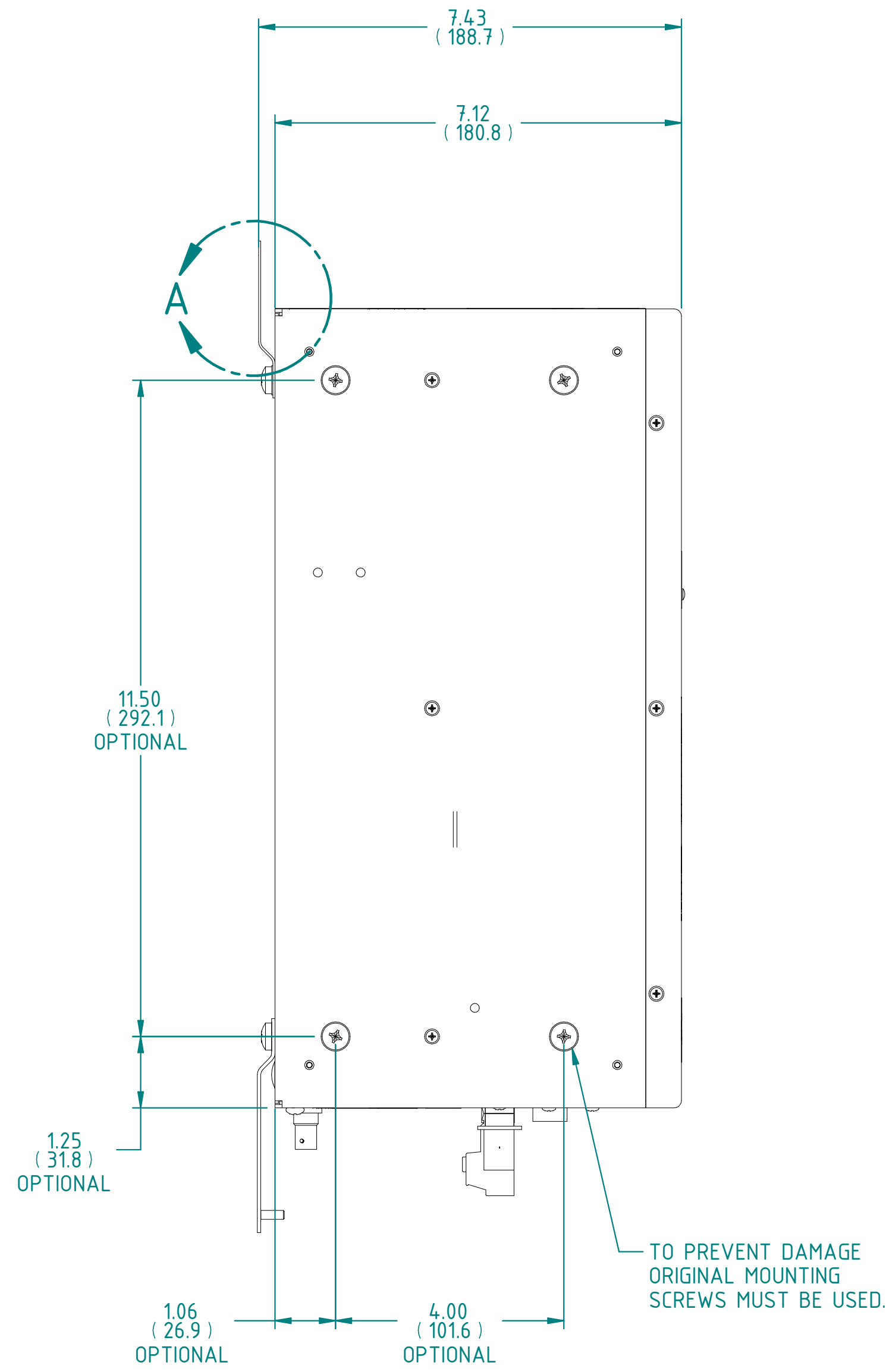

- NOTES: UNLESS OTHER SPECIFIED
1. ALL DIMENSIONS ARE APPROXIMATE.
  2. 3.0in (76mm) RECOMMENDED CLEARANCE ON THE TOP FOR FAN.
  3. 5.0in (127mm) RECOMMENDED CLEARANCE ON THE BOTTOM FOR CABLES.

UNLESS OTHERWISE SPECIFIED  
 DIMENSIONS ARE IN INCHES  
 AND TOLERANCES ARE:  
 2 PLACE DECIMALS ±.005  
 3 PLACE DECIMALS ±.0005  
 4 PLACE DECIMALS ±.00005  
 ANGLES ±1° FRACTIONS 1/32 SURFACE FINISH  
**GD & T Standard ASME Y 14.5**  
 SECONDARY DIMENSIONS  
 ARE PROVIDED FOR  
 REFERENCE ONLY

This PROPRIETARY Document is  
 property of Branson Ultrasonics  
 Corp., Brookfield, CT.  
 It is confidential in nature,  
 non-transferable, and issued with  
 the clear understanding that it is  
 not traced or copied without  
 permission and is returnable upon  
 demand.  
 Article or material must comply  
 with requirements stipulated by  
 RoHS in its current version.

MATERIAL:  
 N/A  
 Material Spec. N/A  
 FINISH:  
 N/A  
 Finish Spec. N/A

NAME	DATE
DRAWN JFBH	12/06/11
CHECKED E. R.	12/06/11
APPROVED JFBH	12/06/11
SCALE: 1:2	SHEET 1 OF 1

BRANSON		TITLE	
		OUTLINE DCX VALUE VRT SM	
AGENCY PART	NO	WEIGHT	0.000 lbm
BUC CLASSIFICATION	3 Important	SIZE/DWG NO	931-132-1814
IP CLASSIFICATION	NO	REV	03

SOLID EDGE