

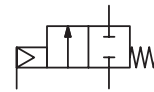

VALVES

pressure operated
for steam applications
external threaded ports, PN40, M25x1,5 and M36x2

NC



NO

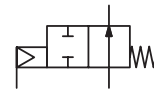

2/2
Series
R298

FEATURES

- Compact 2/2 NC-NO disc valve, stainless steel body, threaded ports
- Ruggedly built, particularly recommended for:
 - use with superheated water and steam, up to max. 240°C
 - high ambient temperatures, up to 180°C
 - use in corrosive environments
- Valve equipped with a piston operator
- Allowable backpressure 20 bar⁽¹⁾
- Optical position indicator as standard
- Reliable operation at low pilot pressures
- High-performance, maintenance-free stuffing box
- The valves satisfy Pressure Equipment Directive 2014/68/EU, article 4.3

GENERAL

fluids (*)	temperature range	disc seal (*)
air and gas groups 1 & 2 superheated water, liquids groups 1 & 2 and steam	-10°C to +240°C	PEEK

Differential pressure	0 to 40 bar [1 bar = 100 kPa]
Maximum allowable pressure	40 bar (within the specified limits, see diagram I)
Ambient temperature range	-10°C to +180°C
Maximum viscosity	600 cSt (mm ² /s)
Pilot fluid	Air
Max. pilot pressure	10 bar
Min. pilot pressure	See below

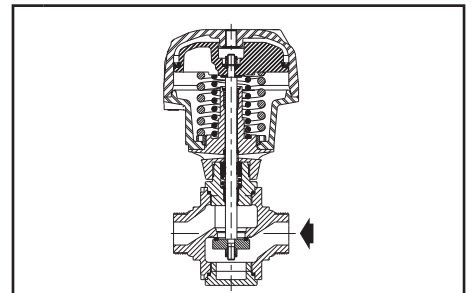

NC function

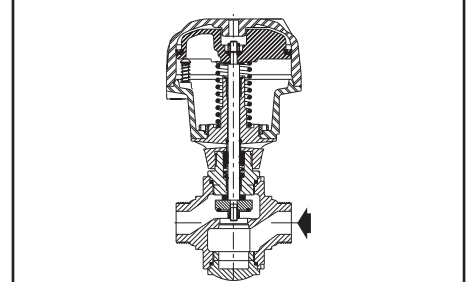

NO function

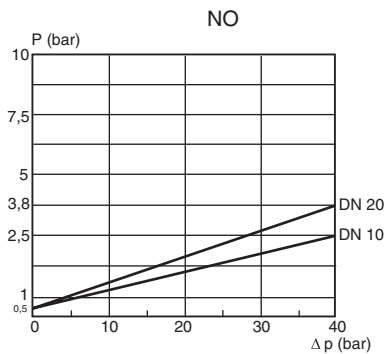
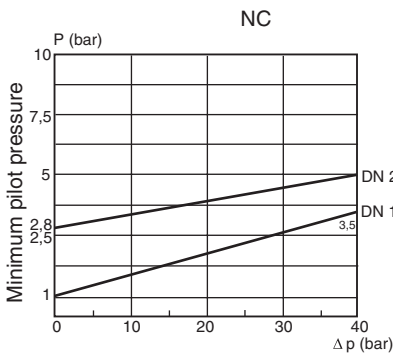

MATERIALS IN CONTACT WITH FLUID

(*) Ensure that the compatibility of the fluids in contact with the materials is verified

Valve body and plug	Stainless steel
Stuffing box housing	Stainless steel
Stem, disc	Stainless steel
Stuffing box packing	PTFE chevrons
Disc seal	PEEK
Valve body seal	PTFE

OTHER MATERIALS

Operator	Aluminium
Optical position indicator	Aluminium

SPECIFICATIONS

pipe size	DN	flow coefficient Kv		maximum allowable pressure (bar)	pilot pressure (bar)		operator diameter (mm)	catalogue number	
		(m ³ /h)	(l/min)		min.	max.		pilot connection	
								G 1/8	1/8 NPT
NC - Normally closed									
M25x1,5	10	2,64	47	40	*	10	80	R298B615	R298B635
M36x2	20	7,56	126	40	*	10	100	R298B616	R298B636
NO - Normally open									
M25x1,5	10	2,26	38	40	*	10	80	R298B613	R298B633
M36x2	20	6,12	102	40	*	10	100	R298B642	R298B662

* Minimum pilot pressure varies with differential pressure. See piloting chart above.

⁽¹⁾ Allowable max. back pressure 20 bar, see page: 18 ("INSTALLATION").

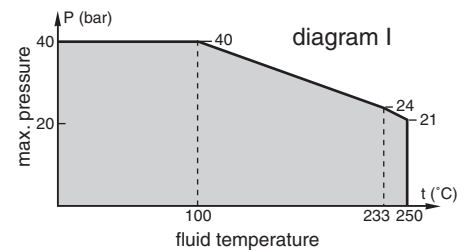

00105GB-2017/R01
Availability, design and specifications are subject to change without notice. All rights reserved.

INSTALLATION

- The valves can be mounted in any position without affecting operation
- In normal use: fluid entry under the disc (for fluid entry above the disc, contact us)

SPARE PARTS KITS

catalogue number	spare parts kit no.		
	piston seal	actuator spring	stem, disc, seals
R298B615/B635	C140233	C140236	C140711
R298B616/B636	C140234	C140238	C140712
R298B613/B633	C140233	C140237	C140714
R298B642/B662	C140234	C140239	C140715

ORDERING EXAMPLES:

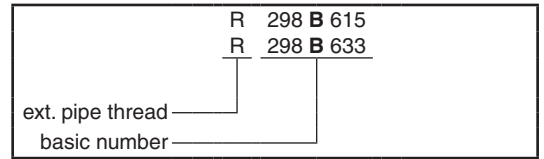

ORDERING EXAMPLES KITS:

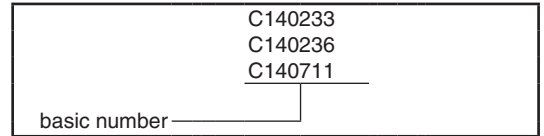

DIMENSIONS (mm), WEIGHT (kg)

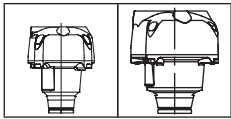

TYPE 01-02
Prefix "R"

NC, normally closed

NO, normally open

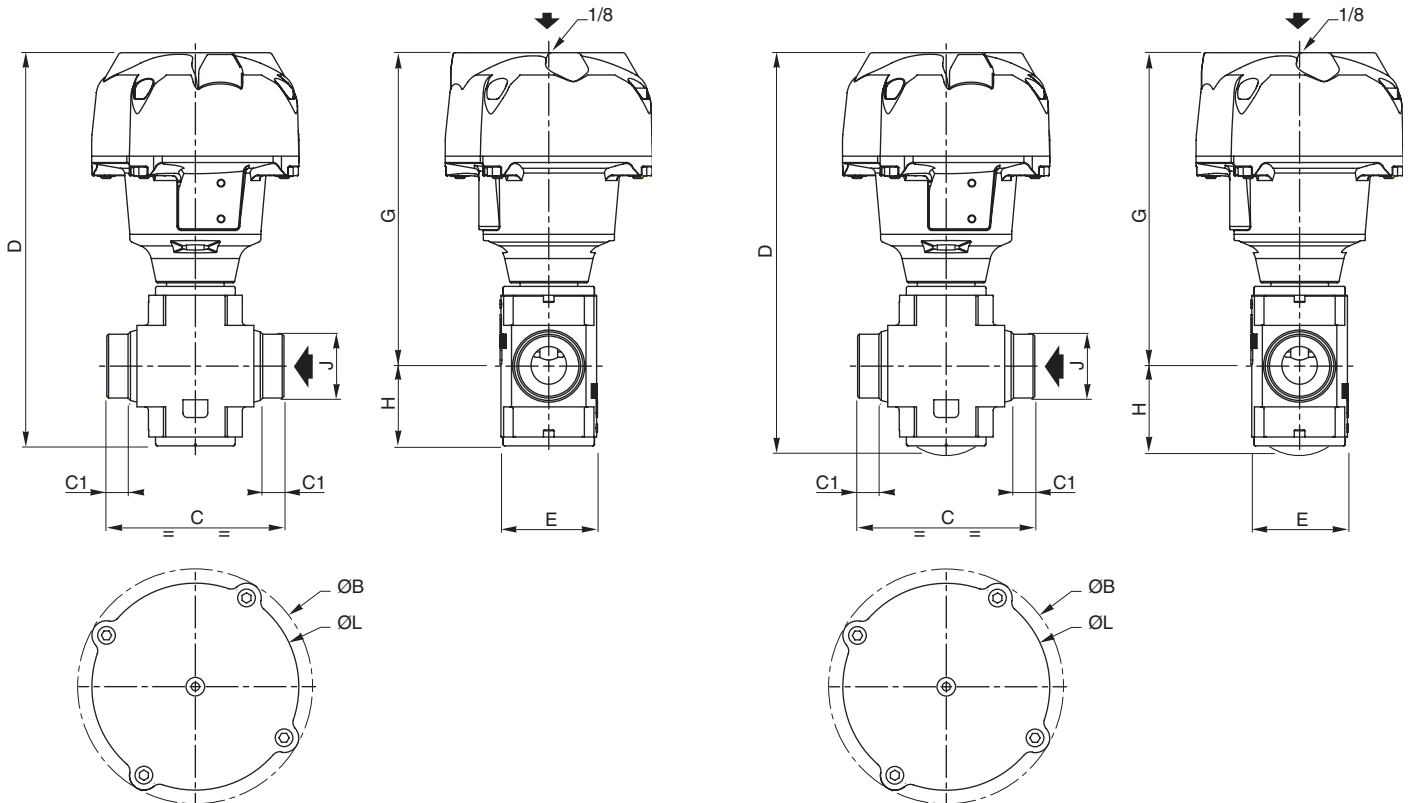

	type	DN	operator diameter	catalogue number	ØB	C	C1	D	E	G	H	J	ØL	weight
NC	01	10	80	R298B615/B635	110	76	11,5	192,6	44	155,6	37	M25 x 1,5	95	2
	02	20	100	R298B616/B636	132	100	12	221,9	54	176,9	45	M36 x 2	117	3,5
NO	01	10	80	R298B613/B633	110	76	11,5	197,6	44	155,6	42	M25 x 1,5	95	2
	02	20	100	R298B642/B662	132	100	12	226,9	54	176,9	50	M36 x 2	117	3,5