



Failure Modes, Effects and Diagnostic Analysis

Project:

Emerson's Rosemount 248 and 644 Rail Mount Temperature Transmitters
with RK and 4-20mA output

Customer:

Rosemount Inc.

(Emerson Automation Solutions)

Shakopee

MN - USA

Contract No.: Q21/07-076-C

Report No.: Ros 21/07-076-C R002

Version V1, Revision R1; August 2021

Jürgen Hochhaus

Management summary

This report summarizes the results of the hardware assessment carried out on the Rosemount 248 and 644 Rail Mount Temperature Transmitters with RK and 4-20mA output and product version V01.xx.xx. Table 1 gives an overview of the considered variants.

The hardware assessment consists of a Failure Modes, Effects and Diagnostics Analysis (FMEDA). A FMEDA is one of the steps taken to achieve functional safety assessment of a device per IEC 61508. From the FMEDA, failure rates are determined and consequently the Safe Failure Fraction (SFF) can be calculated for a subsystem. For full assessment purposes all requirements of IEC 61508 must be considered.

Table 1: Overview of the considered variants

	Description	Name	HART
[V1]	DIN rail mounted 2w programmable temperature transmitters	Rosemount 248R*QT*RK ¹	5 and 7
		Rosemount 644R*QT*RK ¹	5 and 7
		Rosemount 644T*QT*RK ¹	5 and 7

For safety applications only the described variants of the Rosemount 248 and 644 Rail Mount Temperature Transmitters with RK and 4-20mA output have been considered. All other possible variants and configurations are not covered by this report.

The failure modes used in this analysis are from the *exida* Electrical Component Reliability Handbook (see [N2]). The failure rates used in this analysis are the basic failure rates from the Siemens standard SN 29500 (see [N3]). This failure rate database is specified in the safety requirements specification from Rosemount Inc. for the Rosemount 248 and 644 Rail Mount Temperature Transmitters with RK and 4-20mA output.

The Rosemount 248 and 644 Rail Mount Temperature Transmitters with RK and 4-20mA output can be considered to be Type B² elements with a hardware fault tolerance of 0.

The configurations that were considered for the FMEDA are “single”, “redundant” and “dual”.

Single:

Only one sensor is measured, the signal is evaluated to control the current output. In case of device variants with two inputs, one of the inputs is not used.

Dual:

Two sensors are measured. The evaluation of the signals includes a mathematical combination such as difference of two temperatures. The result of the evaluation is used to control the output.

Redundant:

Two sensors are measured and evaluated. The two results are compared; the output is set to the safe state if the difference between the evaluated values exceeds a defined limit

The following tables show how the above stated requirements are fulfilled for the considered Rosemount 248 and 644 Rail Mount Temperature Transmitters with RK and 4-20mA output.

¹ The “*” represent various options which have no impact on the safety aspects of the device.

² Type B element: “Complex” subsystem (using micro controllers or programmable logic); for details see 7.4.4.1.3 of IEC 61508-2.

Table 2: Summary - Failure rates for 248 RK, 644 RK with single sensor configuration

Failure category	IEC 61508:2010 ³ Failure rates (in FIT)
Safe Detected (λ_{SD})	0
Safe Undetected (λ_{SU})	0
Dangerous Detected (λ_{DD})	452
Dangerous Detected (λ_{dd}); by internal diagnostics or indirectly ⁴	369
High (λ_H); detected by the logic solver	17
Low (λ_L); detected by the logic solver	49
Annunciation Detected (λ_{AD})	17
Dangerous Undetected (λ_{DU})	28
Annunciation Undetected (λ_{AU})	11
No effect ($\lambda_{\#}$)	216
No part (λ_{-})	289
Total failure rate of the safety function (λ_{Total})	481
Safe failure fraction (SFF)⁵	94%
DC	94%
SIL AC⁶	SIL 2

³ It is assumed that practical fault insertion tests can demonstrate the correctness of the failure effects assumed during the FMEDAs.

⁴ "indirectly" means that these failures are not necessarily detected by diagnostics but lead to either fail low or fail high failures depending on the transmitter setting and are therefore detectable.

⁵ The complete sensor element will need to be evaluated to determine the overall Safe Failure Fraction. The number listed is for reference only.

⁶ SIL AC (architectural constraints) means that the calculated values are within the range for hardware architectural constraints for the corresponding SIL but does not imply all related IEC 61508 requirements are fulfilled. In addition it must be shown that the device has a suitable systematic capability for the required SIL and that the entire safety function can fulfill the required PFD_{AVG} / PFH value.

Table 3: Summary - Failure rates for 248 RK, 644 RK redundant sensor configuration

Failure category	IEC 61508:2010 ⁷ Failure rates (in FIT)
Safe Detected (λ_{SD})	0
Safe Undetected (λ_{SU})	0
Dangerous Detected (λ_{DD})	495
Dangerous Detected (λ_{dd}); by internal diagnostics or indirectly ⁸	410
High (λ_H); detected by the logic solver	17
Low (λ_L); detected by the logic solver	49
Annunciation Detected (λ_{AD})	20
Dangerous Undetected (λ_{DU})	23
Annunciation Undetected (λ_{AU})	12
No effect ($\lambda_{\#}$)	269
No part ($\lambda_{.}$)	197
Total failure rate of the safety function (λ_{Total})	519
Safe failure fraction (SFF) ⁹	95%
DC	95%
SIL AC ¹⁰	SIL 2

⁷ It is assumed that practical fault insertion tests can demonstrate the correctness of the failure effects assumed during the FMEDAs.

⁸ "indirectly" means that these failures are not necessarily detected by diagnostics but lead to either fail low or fail high failures depending on the transmitter setting and are therefore detectable.

⁹ The complete sensor element will need to be evaluated to determine the overall Safe Failure Fraction. The number listed is for reference only.

¹⁰ SIL AC (architectural constraints) means that the calculated values are within the range for hardware architectural constraints for the corresponding SIL but does not imply all related IEC 61508 requirements are fulfilled. In addition it must be shown that the device has a suitable systematic capability for the required SIL and that the entire safety function can fulfill the required PFD_{AVG} / PFH value.

Table 4: Summary - Failure rates for 248 RK, 644 RK with dual sensor configuration

Failure category	IEC 61508:2010 ¹¹ Failure rates (in FIT)
Safe Detected (λ_{SD})	0
Safe Undetected (λ_{SU})	0
Dangerous Detected (λ_{DD})	472
Dangerous Detected (λ_{dd}); by internal diagnostics or indirectly ¹²	386
High (λ_H); detected by the logic solver	17
Low (λ_L); detected by the logic solver	49
Annunciation Detected (λ_{AD})	20
Dangerous Undetected (λ_{DU})	34
Annunciation Undetected (λ_{AU})	11
No effect ($\lambda_{\#}$)	258
No part (λ_{-})	218
Total failure rate of the safety function (λ_{Total})	506
Safe failure fraction (SFF) ¹³	93%
DC	93%
SIL AC ¹⁴	SIL 2

The failure rates are valid for the useful life of the Rosemount 248 and 644 Rail Mount Temperature Transmitters with RK and 4-20mA output (see Appendix A) when operating as defined in the considered scenarios.

¹¹ It is assumed that practical fault insertion tests can demonstrate the correctness of the failure effects assumed during the FMEDAs.

¹² "indirectly" means that these failures are not necessarily detected by diagnostics but lead to either fail low or fail high failures depending on the transmitter setting and are therefore detectable.

¹³ The complete sensor element will need to be evaluated to determine the overall Safe Failure Fraction. The number listed is for reference only.

¹⁴ SIL AC (architectural constraints) means that the calculated values are within the range for hardware architectural constraints for the corresponding SIL but does not imply all related IEC 61508 requirements are fulfilled. In addition it must be shown that the device has a suitable systematic capability for the required SIL and that the entire safety function can fulfill the required PFD_{AVG} / PFH value.

Table of Contents

Management summary	2
1 Purpose and Scope	7
2 Project management.....	8
2.1 <i>exida</i>	8
2.2 Roles of the parties involved	8
2.3 Standards / Literature used	9
2.4 <i>exida</i> tools used.....	9
2.5 Reference documents	10
2.5.1 Documentation provided by the manufacturer and the vendor	10
2.5.2 Documentation generated by the manufacturer and <i>exida</i>	10
3 Product Description.....	11
4 Failure Modes, Effects, and Diagnostic Analysis	13
4.1 Description of the failure categories	13
4.2 Methodology – FMEDA, Failure rates.....	14
4.2.1 FMEDA.....	14
4.2.2 Failure rates.....	14
4.2.3 Assumptions.....	15
4.3 Results.....	16
4.3.1 248 RK, 644 RK with single sensor configuration	17
4.3.2 248 RK, 644 RK with redundant sensor configuration.....	18
4.3.3 248 RK, 644 RK with dual sensor configuration	19
5 Using the FMEDA results.....	20
5.1 Example PFD _{AVG} / PFH calculation.....	20
6 Terms and Definitions	22
7 Status of the document	23
7.1 Liability	23
7.2 Releases	23
7.3 Release Signatures.....	23
Appendix A: Lifetime of Critical Components.....	24
Appendix B: Determining Safety Integrity Level.....	25
Appendix C: Using the FMEDA results	29
Appendix C.1: 248 RK, 644 RK with thermocouple.....	29
Appendix C.2: 248 RK, 644 RK with RTD.....	31
Appendix C.3: 248 RK, 644 RK in dual mode (TC, RTD or mixed sensor types)	34
Appendix C.4: 248 RK, 644 RK in redundant mode (TC, RTD or mixed) with drift monitoring	37

1 Purpose and Scope

This document shall describe the results of the hardware assessment carried out on the Rosemount 248 and 644 Rail Mount Temperature Transmitters with RK and 4-20mA output and product version V01.xx.xx.

The FMEDA builds the basis for an evaluation whether an element including the described Rosemount 248 and 644 Rail Mount Temperature Transmitters with RK and 4-20mA output meets the average Probability of Failure on Demand (PFD_{AVG}) / Probability of dangerous Failure per Hour (PFH) requirements and if applicable the architectural constraints / minimum hardware fault tolerance requirements per IEC 61508 / IEC 61511. It **does not** consider any calculations necessary for proving intrinsic safety.

2 Project management

2.1 *exida*

exida is one of the world's leading accredited Certification Bodies and knowledge companies, specializing in automation system safety cybersecurity, and availability with over 400 years of cumulative experience in functional safety. Founded by several of the world's top reliability and safety experts from assessment organizations and manufacturers, *exida* is a global company with offices around the world. *exida* offers training, coaching, project oriented system consulting services, safety lifecycle engineering tools, detailed product assurance, cyber-security and functional safety certification, and a collection of on-line safety and reliability resources. *exida* maintains a comprehensive failure rate and failure mode database on process equipment based on 250 billion unit operating hours of field failure data.

2.2 Roles of the parties involved

Rosemount Inc.	Vendor of the Rosemount 248 and 644 Rail Mount Temperature Transmitters with RK and 4-20mA output.
Manufacturer	Manufacturer of the Rosemount 248 and 644 Rail Mount Temperature Transmitters with RK and 4-20mA output
<i>exida</i>	Performed the hardware assessment.

The manufacturer contracted *exida* in October 2019 with the FMEDA of the above-mentioned devices and in August 2021 with the creation of this report.

2.3 Standards / Literature used

The services delivered by *exida* were performed based on the following standards / literature.

[N1]	IEC 61508-2:2010	Functional Safety of Electrical/Electronic/Programmable Electronic Safety-Related Systems
[N2]	Electrical Component Reliability Handbook, 3rd Edition, 2012	<i>exida</i> LLC, Electrical Component Reliability Handbook, Third Edition, 2012, ISBN 978-1-934977-04-0
[N3]	SN 29500-1:01.2004 SN 29500-1 H1:07.2013 SN 29500-2:09.2010 SN 29500-3:06.2009 SN 29500-4:03.2004 SN 29500-5:06.2004 SN 29500-7:11.2005 SN 29500-9:11.2005 SN 29500-10:12.2005 SN 29500-11:07.2013 SN 29500-12:02.2008 SN 29500-15:07.2009 SN 29500-16:08.2010	Siemens standard with failure rates for components
[N4]	Goble, W.M. 2010	Control Systems Safety Evaluation and Reliability, 3rd edition, ISA, ISBN 97B-1-934394-80-9. Reference on FMEDA methods
[N5]	Scaling the Three Barriers, Recorded Web Seminar, June 2013,	Scaling the Three Barriers, Recorded Web Seminar, June 2013, http://www.exida.com/Webinars/Recordings/SIF-Verification-Scaling-the-Three-Barriers
[N6]	Meeting Architecture Constraints in SIF Design, Recorded Web Seminar, March 2013	http://www.exida.com/Webinars/Recordings/Meeting-Architecture-Constraints-in-SIF-Design

2.4 *exida* tools used

[T1]	SILcal V8.0.11	FMEDA Tool
[T2]	exSILentia Ultimate V3.7.2.1122	SIL Verification Tool

2.5 Reference documents

2.5.1 Documentation provided by the manufacturer and the vendor

[D1]	248 - 00809-0300-4825_4-19_UF.pdf	Preliminary Safety Manual, date April 2021
[D2]	644 - 00809-0600-4728_4-19_UF.pdf	Preliminary Safety Manual, date April 2021
[D3]	XXXX ¹⁵ -1-03-PDF_V3R0.pdf	Schematic PCB Documentation, V3R0, dated 2019-09-17
[D4]	XXXX ¹⁵ -SMD2__2007.pdf	Part List / Bill of Material, _2007, dated 2019-10-03
[D5]	XXXX ¹⁵ Product Version Log V01.00.xlsx	

The list above only means that the referenced documents were provided as basis for the FMEDA but it does not mean that *exida* checked the correctness and completeness of these documents.

2.5.2 Documentation generated by the manufacturer and *exida*

[R1]	FMEDA - XXXX ¹⁵ - Dual RTD V1R12 of 20.05.2020
[R2]	FMEDA - XXXX ¹⁵ - Dual TC, with External CJC V1R12 of 20.05.2020
[R3]	FMEDA - XXXX ¹⁵ - Dual TC, with Int CJC (Sensor drift) V1R12 of 20.05.2020
[R4]	FMEDA - XXXX ¹⁵ - Dual TC, with Int CJC V1R12 of 20.05.2020
[R5]	FMEDA - XXXX ¹⁵ - Single TC, with Int CJC V1R12 of 20.05.2020
[R6]	Change log for FMEDAs after first FMEDA Report.docx

¹⁵ "XXXX" represents the device type number.

3 Product Description

The Rosemount 248 and 644 Rail Mount Temperature Transmitters with RK and 4-20mA output are rail mounted 2 wire transmitters. The input is galvanically isolated from the 4-20mA output. The devices can be configured via a control panel attached to an extension port or external devices using HART or loop link protocol.

The Transmitters can be considered as a Type B¹⁶ elements with a hardware fault tolerance of 0.

The safety function of the Rosemount 248 and 644 Rail Mount Temperature Transmitters with RK and 4-20mA output is defined as follows:

Conversion of voltage signals, potentiometer, linear resistance, RTD sensor signals or thermocouple sensor signals in hazardous areas to the output signal within specified accuracy.

Figure 1 shows the block diagram of 248 RK, 644 RK devices in single sensor configuration and Figure 2 shows the block diagram of 644RK devices in dual or redundant sensor configuration.

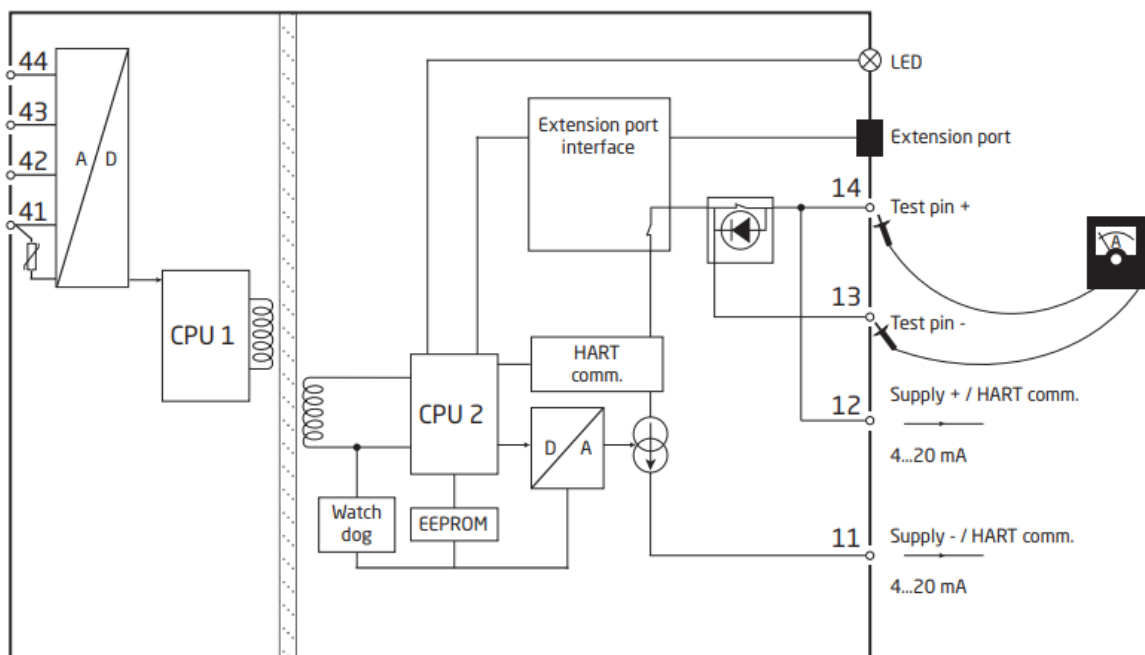

Figure 1: Block Diagram of 248 RK, 644 RK in single sensor configuration

¹⁶ Type B element: "Complex" subsystem (using micro controllers or programmable logic); for details see 7.4.4.1.3 of IEC 61508-2.

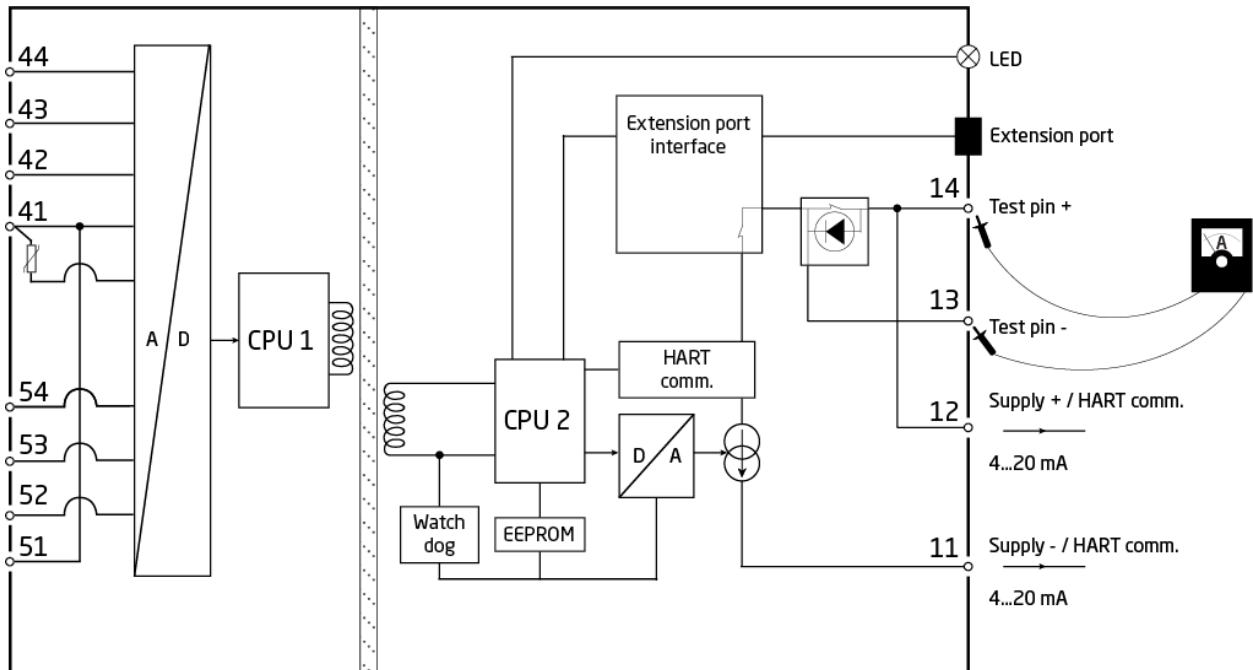

Figure 2: Block Diagram of 644 RK in dual or redundant configuration

4 Failure Modes, Effects, and Diagnostic Analysis

The Failure Modes, Effects, and Diagnostic Analysis was done together with and is documented in [R1] to [R5].

4.1 Description of the failure categories

In order to judge the failure behavior of the Rosemount 248 and 644 Rail Mount Temperature Transmitters with RK and 4-20mA output, the following definitions for the failure of the product were considered.

Fail-Safe State	The fail-safe state is defined as output reaching the user defined threshold value.
Fail Safe	A safe failure (S) is defined as a failure that plays a part in implementing the safety function that: <ul style="list-style-type: none">a) results in the spurious operation of the safety function to put the EUC (or part thereof) into a safe state or maintain a safe state; or,b) increases the probability of the spurious operation of the safety function to put the EUC (or part thereof) into a safe state or maintain a safe state.
Fail Dangerous	A dangerous failure (D) is defined as a failure that plays a part in implementing the safety function that: <ul style="list-style-type: none">a) deviates the output current by more than 2% of full span and prevents a safety function from operating when required (demand mode) or causes a safety function to fail (continuous mode) such that the EUC is put into a hazardous or potentially hazardous state; or,b) decreases the probability that the safety function operates correctly when required.
Dangerous Undetected	Failure that is dangerous and that is not being diagnosed.
Dangerous Detected	Failure that is dangerous but is detected by internal or external testing.
Fail high	A fail high failure (H) is defined as a failure that causes the output signal to go to the maximum output current (> 21mA).
Fail low	A fail low failure (L) is defined as a failure that causes the output signal to go to the minimum output current (< 3.6mA).
Annunciation	Failure that does not directly impact safety but does impact the ability to detect a future fault (such as a fault in a diagnostic circuit). Annunciation failures are divided into annunciation detected (AD) and annunciation undetected (AU) failures.
No effect	Failure mode of a component that plays a part in implementing the safety function but is neither a safe failure nor a dangerous failure.
No part	Component that plays no part in implementing the safety function but is part of the circuit diagram and is listed for completeness.

4.2 Methodology – FMEDA, Failure rates

4.2.1 FMEDA

A Failure Modes and Effects Analysis (FMEA) is a systematic way to identify and evaluate the effects of different component failure modes, to determine what could eliminate or reduce the chance of failure, and to document the system in consideration.

An FMEDA (Failure Mode Effect and Diagnostic Analysis) is an FMEA extension. It combines standard FMEA techniques with extension to identify online diagnostics techniques and the failure modes relevant to safety instrumented system design. It is a technique recommended to generate failure rates for each important category (safe detected, safe undetected, dangerous detected, dangerous undetected, fail high, fail low) in the safety models. The format for the FMEDA is an extension of the standard FMEA format from MIL STD 1629A, Failure Modes and Effects Analysis.

4.2.2 Failure rates

The failure modes used in this analysis are from the *exida* Electrical Component Reliability Handbook (see [N2]). The failure rates used in this analysis are the basic failure rates from the Siemens standard SN 29500 (see [N3]). The rates were chosen in a way that is appropriate for safety integrity level verification calculations and the intended applications. It is expected that the actual number of field failures due to random events will be less than the number predicted by these failure rates.

For hardware assessment according to IEC 61508 only random equipment failures are of interest. It is assumed that the equipment has been properly selected for the application and is adequately commissioned such that early life failures (infant mortality) may be excluded from the analysis.

Failures caused by external events should be considered as random failures. Examples of such failures are loss of power or physical abuse.

The assumption is also made that the equipment is maintained per the requirements of IEC 61508 or IEC 61511 and therefore a preventative maintenance program is in place to replace equipment before the end of its “useful life”.

The user of these numbers is responsible for determining their applicability to any particular environment. Some industrial plant sites have high levels of stress. Under those conditions the failure rate data is adjusted to a higher value to account for the specific conditions of the plant.

Accurate plant specific data may be used for this purpose. If a user has data collected from a good proof test reporting system such as *exida* SILStat™ that indicates higher failure rates, the higher numbers shall be used.

4.2.3 Assumptions

The following assumptions have been made during the Failure Modes, Effects, and Diagnostic Analysis of the Rosemount 248 and 644 Rail Mount Temperature Transmitters with RK and 4-20mA output.

- Failure rates are constant, wear out mechanisms are not included.
- Propagation of failures is not relevant.
- Sufficient tests are performed prior to shipment to verify the absence of vendor and/or manufacturing defects that prevent proper operation of specified functionality to product specifications or cause operation different from the design analyzed.
- Practical fault insertion tests can demonstrate the correctness of the failure effects assumed during the FMEDA and the diagnostic coverage provided by the automatic diagnostics.
- The correct parameterization is verified by the user.
- The safety accuracy for all configurations is 2% of full span.
- The device is locked against unintended operation/modification.
- The worst-case diagnostic test rate and reaction time is 60s.
- External power supply failure rates are not included.
- The Mean Time To Restoration (MTTR) is considered to be 24 hours.
- The Rosemount 248 and 644 Rail Mount Temperature Transmitters with RK and 4-20mA output are installed per the manufacturer's instructions.
- The listed failure rates are valid for operating stress conditions typical of an industrial field environment with temperature limits within the manufacturer's rating and an average temperature over a long period of time of 40°C. For higher average temperatures, the failure rates should be multiplied with an experience-based factor of e.g. 1.5 for 50°C, 2.5 for 60°C and 5 for 80°C.
- Only the described variants are used for safety applications.
- The application program in the safety logic solver is configured according to NAMUR NE43 to detect under-range and over-range failures and does not automatically trip on these failures; therefore, these failures have been classified as dangerous detected failures.
- All components that are not part of the safety function (e.g. HART circuitry) and cannot influence the safety function (feedback immune) are excluded.

4.3 Results

$$DC = \lambda_{DD} / (\lambda_{DD} + \lambda_{DU})$$

$$\lambda_{total} = \lambda_{SD} + \lambda_{SU} + \lambda_{DD} + \lambda_{DU}$$

According to IEC 61508 the architectural constraints of an element must be determined. This can be done by following the 1_H approach according to 7.4.4.2 of IEC 61508-2 or the 2_H approach according to 7.4.4.3 of IEC 61508-2.

The 1_H approach involves calculating the Safe Failure Fraction for the entire element.

The 2_H approach involves assessment of the reliability data for the entire element according to 7.4.4.3.3 of IEC 61508-2.

This assessment supports the 1_H approach.

According to 3.6.15 of IEC 61508-4, the Safe Failure Fraction is the property of a safety related element that is defined by the ratio of the average failure rates of safe plus dangerous detected failures and safe plus dangerous failures. This ratio is represented by the following equation:

$$SFF = (\sum \lambda_S \text{ avg} + \sum \lambda_{DD} \text{ avg}) / (\sum \lambda_S \text{ avg} + \sum \lambda_{DD} \text{ avg} + \sum \lambda_{DU} \text{ avg})$$

When the failure rates are based on constant failure rates, as in this analysis, the equation can be simplified to:

$$SFF = (\sum \lambda_S + \sum \lambda_{DD}) / (\sum \lambda_S + \sum \lambda_{DD} + \sum \lambda_{DU})$$

Where:

λ_S = Fail Safe

λ_{DD} = Fail Dangerous Detected

λ_{DU} = Fail Dangerous Undetected

As the Rosemount 248 and 644 Rail Mount Temperature Transmitters with RK and 4-20mA output is only one part of an element, the architectural constraints should be determined for the entire sensor element.

4.3.1 248 RK, 644 RK with single sensor configuration

The FMEDA carried out on the Rosemount 248 and 644 Rail Mount Temperature Transmitters with RK and 4-20mA output under the assumptions described in section 4.2.3 and the definitions given in section 4.1 and 4.2 leads to the following failure rates:

Table 5: Failure rates for 248 RK, 644 RK with single sensor configuration

Failure category	IEC 61508:2010 ¹⁷ Failure rates (in FIT)
Safe Detected (λ_{SD})	0
Safe Undetected (λ_{SU})	0
Dangerous Detected (λ_{DD})	452
Dangerous Detected (λ_{dd}); by internal diagnostics or indirectly ¹⁸	369
High (λ_H); detected by the logic solver	17
Low (λ_L); detected by the logic solver	49
Annunciation Detected (λ_{AD})	17
Dangerous Undetected (λ_{DU})	28
Annunciation Undetected (λ_{AU})	11
No effect ($\lambda_{\#}$)	216
No part (λ_{-})	289
Total failure rate of the safety function (λ_{Total})	481
Safe failure fraction (SFF)¹⁹	94%
DC	94%
SIL AC²⁰	SIL 2

¹⁷ It is assumed that practical fault insertion tests can demonstrate the correctness of the failure effects assumed during the FMEDAs.

¹⁸ "indirectly" means that these failures are not necessarily detected by diagnostics but lead to either fail low or fail high failures depending on the transmitter setting and are therefore detectable.

¹⁹ The complete sensor element will need to be evaluated to determine the overall Safe Failure Fraction. The number listed is for reference only.

²⁰ SIL AC (architectural constraints) means that the calculated values are within the range for hardware architectural constraints for the corresponding SIL but does not imply all related IEC 61508 requirements are fulfilled. In addition it must be shown that the device has a suitable systematic capability for the required SIL and that the entire safety function can fulfill the required PFD_{AVG} / PFH value.

4.3.2 248 RK, 644 RK with redundant sensor configuration

The FMEDA carried out on the Rosemount 248 and 644 Rail Mount Temperature Transmitters with RK and 4-20mA output under the assumptions described in section 4.2.3 and the definitions given in section 4.1 and 4.2 leads to the following failure rates.

In redundant sensor configuration, two sensors are measured and evaluated. The two results are compared; the output is set to the safe state if the difference between the evaluated values exceeds a defined limit.

Table 6: Failure rates for 248 RK, 644 RK with redundant sensor configuration

Failure category	IEC 61508:2010 ²¹ Failure rates (in FIT)
Safe Detected (λ_{SD})	0
Safe Undetected (λ_{SU})	0
Dangerous Detected (λ_{DD})	495
Dangerous Detected (λ_{dd}); by internal diagnostics or indirectly ²²	410
High (λ_H); detected by the logic solver	17
Low (λ_L); detected by the logic solver	49
Annunciation Detected (λ_{AD})	20
Dangerous Undetected (λ_{DU})	23
Annunciation Undetected (λ_{AU})	12
No effect ($\lambda_{\#}$)	269
No part (λ_{-})	197
Total failure rate of the safety function (λ_{Total})	519
Safe failure fraction (SFF) ²³	95%
DC	95%
SIL AC ²⁴	SIL 2

²¹ It is assumed that practical fault insertion tests can demonstrate the correctness of the failure effects assumed during the FMEDAs.

²² "indirectly" means that these failures are not necessarily detected by diagnostics but lead to either fail low or fail high failures depending on the transmitter setting and are therefore detectable.

²³ The complete sensor element will need to be evaluated to determine the overall Safe Failure Fraction. The number listed is for reference only.

²⁴ SIL AC (architectural constraints) means that the calculated values are within the range for hardware architectural constraints for the corresponding SIL but does not imply all related IEC 61508 requirements are fulfilled. In addition it must be shown that the device has a suitable systematic capability for the required SIL and that the entire safety function can fulfill the required PFD_{AVG} / PFH value.

4.3.3 248 RK, 644 RK with dual sensor configuration

The FMEDA carried out on the Rosemount 248 and 644 Rail Mount Temperature Transmitters with RK and 4-20mA output under the assumptions described in section 4.2.3 and the definitions given in section 4.1 and 4.2 leads to the following failure rates.

In dual sensor configuration, two sensors are measured. The evaluation of the signals includes a mathematical combination such as difference of two temperatures. The result of the evaluation is used to control the output.

Table 7: Failure rates for 248 RK, 644 RK with dual sensor configuration

Failure category	IEC 61508:2010 ²⁵ Failure rates (in FIT)
Safe Detected (λ_{SD})	0
Safe Undetected (λ_{SU})	0
Dangerous Detected (λ_{DD})	472
Dangerous Detected (λ_{dd}); by internal diagnostics or indirectly ²⁶	386
High (λ_H); detected by the logic solver	17
Low (λ_L); detected by the logic solver	49
Annunciation Detected (λ_{AD})	20
Dangerous Undetected (λ_{DU})	34
Annunciation Undetected (λ_{AU})	11
No effect ($\lambda_{\#}$)	258
No part (λ_{\cdot})	218
Total failure rate of the safety function (λ_{Total})	506
Safe failure fraction (SFF)²⁷	93%
DC	93%
SIL AC²⁸	SIL 2

²⁵ It is assumed that practical fault insertion tests can demonstrate the correctness of the failure effects assumed during the FMEDAs.

²⁶ "indirectly" means that these failures are not necessarily detected by diagnostics but lead to either fail low or fail high failures depending on the transmitter setting and are therefore detectable.

²⁷ The complete sensor element will need to be evaluated to determine the overall Safe Failure Fraction. The number listed is for reference only.

²⁸ SIL AC (architectural constraints) means that the calculated values are within the range for hardware architectural constraints for the corresponding SIL but does not imply all related IEC 61508 requirements are fulfilled. In addition it must be shown that the device has a suitable systematic capability for the required SIL and that the entire safety function can fulfill the required PFD_{AVG} / PFH value.

5 Using the FMEDA results

Using the failure rate data displayed in section 4.3, and the failure rate data for the associated element devices, an average the Probability of Failure on Demand (PFD_{AVG}) calculation can be performed for the entire safety function.

Probability of Failure on Demand (PFD_{AVG}) calculation uses several parameters, many of which are determined by the particular application and the operational policies of each site. Some parameters are product specific and the responsibility of the manufacturer. Those manufacturer specific parameters are given in this third-party report.

Probability of Failure on Demand (PFD_{AVG}) calculation is the responsibility of the owner/operator of a process and is often delegated to the SIF designer. Product manufacturers can only provide a PFD_{AVG} by making many assumptions about the application and operational policies of a site. Therefore, use of these numbers requires complete knowledge of the assumptions and a match with the actual application and site.

Probability of Failure on Demand (PFD_{AVG}) calculation is best accomplished with *exida's* exSILentia tool. See Appendix C for a complete description of how to determine the Safety Integrity Level for an entire safety function. The mission time used for the calculation depends on the PFD_{AVG} target and the useful life of the product. The failure rates for all the devices of the safety function are required to perform the PFD_{AVG} calculation

The following section gives a simplified example on how to apply the results of the FMEDA.

5.1 Example PFD_{AVG} / PFH calculation

An average Probability of Failure on Demand (PFD_{AVG}) calculation is performed for a single (1001) Temperature transmitter 248 RK, 644 RK with *exida's* exSILentia tool. The failure rate data used in this calculation are displayed in sections 4.3.1. A mission time of 10 and 15 years has been assumed, a Mean Time To Restoration of 24 hours and a maintenance capability of 100%. Table 8 shows the results. The example calculation has been done for the temperature transmitter in single configuration.

Table 8: [V1] – PFD_{AVG} / PFH values

	PFH ²⁹	Mission Time	
		10 years	15 years
248 RK, 644 RK	PFH = 2.8E-08 1/h	PFD _{AVG} = 1.24E-03	PFD _{AVG} = 1.85 E-03

For SIL2 the overall PFD_{AVG} shall be better than 1.00E-02 and the PFH shall be better than 1.00E-06 1/h. As the Rosemount 248 and 644 Rail Mount Temperature Transmitters with RK and 4-20mA output are contributing to the entire safety function they should only consume a certain percentage of the allowed range. Assuming 10% of this range as a reasonable budget they should be better than or equal to 1.00E-03 or 1.00E-07 1/h, respectively. The calculated PFH values is within the allowed range for SIL 2 according to table 2 of IEC 61508-1 and do fulfill the assumption to not claim more than 10% of the allowed range, i.e. to be better than or equal to 1.00E-07 1/h, respectively. The PFD_{AVG} dependent on the Mission Time slightly exceeds the assumed 10% of the allowed range, i.e. 1.00E-03. But as it does not exceed 20% even for 15 years Mission Time, the device may be used also for SIL2 low demand application based on a careful consideration of the failure rates of the other elements in the loop.

²⁹ The PFH value is based on a worst-case diagnostic test rate and a reaction time of 60s. The ratio of the diagnostic test rate to the demand rate shall equal or exceed 100.

The resulting PFD_{AVG} graphs generated from the exSILentia tool for a Mission Time of 10 years without proof test is displayed in Figure 3.

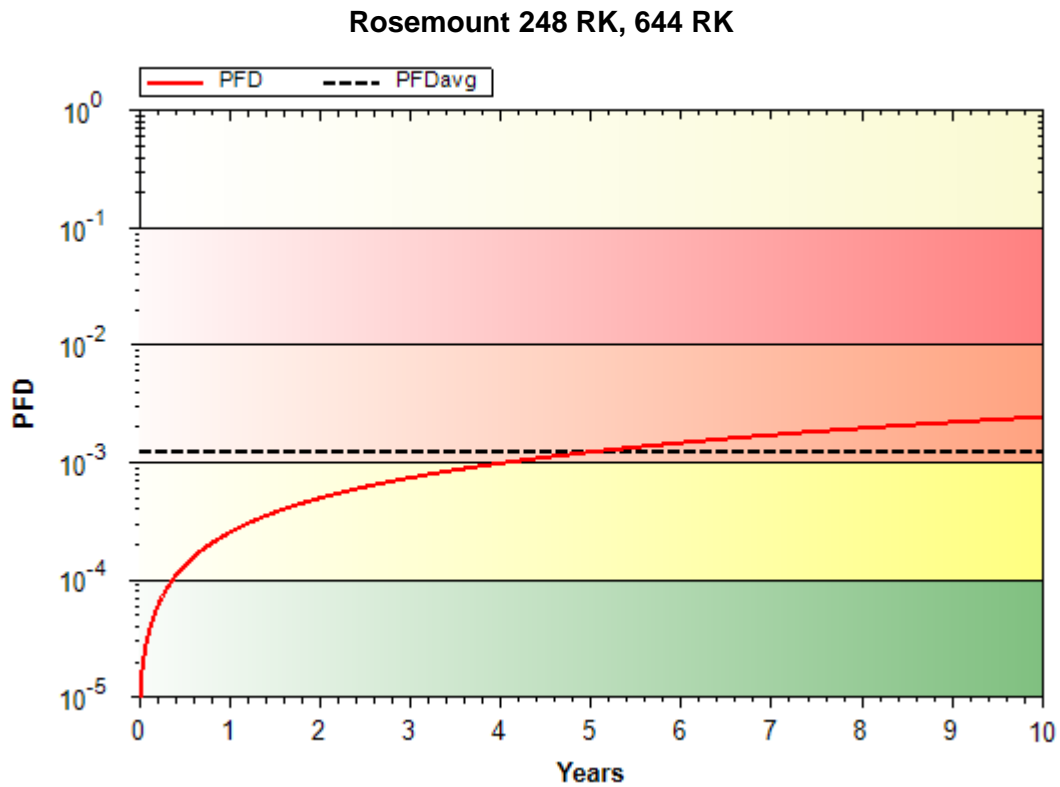

Figure 3: PFD_{AVG} over time

6 Terms and Definitions

Automatic Diagnostics	Tests performed on line internally by the device or, if specified, externally by another device without manual intervention.
DC	Diagnostic Coverage of dangerous failures ($DC = \lambda_{DD} / (\lambda_{DD} + \lambda_{DU})$)
FIT	Failure In Time (1×10^{-9} failures per hour)
FMEDA	Failure Modes, Effects, and Diagnostic Analysis
HFT	Hardware Fault Tolerance A hardware fault tolerance of N means that N+1 is the minimum number of faults that could cause a loss of the safety function.
High demand mode	Mode, where the safety function is only performed on demand, in order to transfer the EUC into a specified safe state, and where the frequency of demands is greater than one per year.
Low demand mode	Mode, where the safety function is only performed on demand, in order to transfer the EUC into a specified safe state, and where the frequency of demands is no greater than one per year.
MTBF	Mean Time Between Failures
MTTR	Mean Time To Restoration
PFD_{AVG}	Average Probability of Failure on Demand
PFH	Probability of dangerous Failure per Hour
SIF	Safety Instrumented Function
SIL	Safety Integrity Level IEC 61508: discrete level (one out of a possible four), corresponding to a range of safety integrity values, where safety integrity level 4 has the highest level of safety integrity and safety integrity level 1 has the lowest.
Type B element	“Complex” element (using micro controllers or programmable logic); for details see 7.4.4.1.3 of IEC 61508-2
T[Proof]	Proof Test Interval

7 Status of the document

7.1 Liability

exida prepares reports based on methods advocated in International standards. Failure rates are obtained from a collection of industrial databases. *exida* accepts no liability whatsoever for the use of these numbers or for the correctness of the standards on which the general calculation methods are based.

Due to future potential changes in the standards, best available information and best practices, the current FMEDA results presented in this report may not be fully consistent with results that would be presented for the identical product at some future time. As a leader in the functional safety market place, *exida* is actively involved in evolving best practices prior to official release of updated standards so that our reports effectively anticipate any known changes. In addition, most changes are anticipated to be incremental in nature and results reported within the previous three year period should be sufficient for current usage without significant question.

Most products also tend to undergo incremental changes over time. If an *exida* FMEDA has not been updated within the last three years and the exact results are critical to the SIL verification you may wish to contact the product vendor to verify the current validity of the results.

7.2 Releases

Version History: V1R1: Corrected device names, reworked reference documentation table;
August 16, 2021
V1R0: Release; August 06, 2021 Based on report 18-10-076-C R030
V1R0

Author: Jürgen Hochhaus – *exida.com* GmbH
Review: See base report

Release status: Released

7.3 Release Signatures

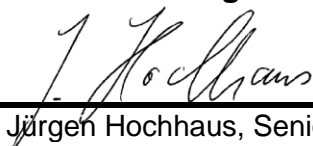

Jürgen Hochhaus, Senior Safety Engineer

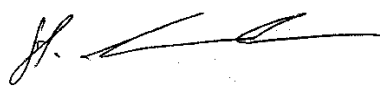

Dipl.-Ing. (Univ.) Stephan Aschenbrenner, Partner, CEO

Appendix A: Lifetime of Critical Components

According to section 7.4.9.5 of IEC 61508-2, a useful lifetime, based on experience, should be assumed.

Although a constant failure rate is assumed by the probabilistic estimation method (see section 4.2.3) this only applies provided that the useful lifetime³⁰ of components is not exceeded. Beyond their useful lifetime, the result of the probabilistic calculation method is meaningless, as the probability of failure significantly increases with time. The useful lifetime is highly dependent on the component itself and its operating conditions.

This assumption of a constant failure rate is based on the bathtub curve. Therefore, it is obvious that the PFD_{AVG} calculation is only valid for components which have this constant domain and that the validity of the calculation is limited to the useful lifetime of each component.

It is assumed that early failures are detected to a huge percentage during the installation period and therefore the assumption of a constant failure rate during the useful lifetime is valid.

The Rosemount 248 and 644 Rail Mount Temperature Transmitters with RK and 4-20mA output do not contain components with reduced useful lifetime which are contributing to the dangerous undetected failure rate and therefore to the PFD_{AVG} calculation. Therefore, there is no limiting factor to the useful lifetime.

When plant experience indicates a shorter useful lifetime than indicated in this appendix, the number based on plant experience should be used.

³⁰ Useful lifetime is a reliability engineering term that describes the operational time interval where the failure rate of a device is relatively constant. It is not a term which covers product obsolescence, warranty, or other commercial issues.

Appendix B: Determining Safety Integrity Level

The information in this appendix is intended to provide the method of determining the Safety Integrity Level (SIL) of a Safety Instrumented Function (SIF). The numbers used in the examples are not for the product described in this report.

Three things must be checked when verifying that a given Safety Instrumented Function (SIF) design meets a Safety Integrity Level (SIL), see [N4] and [N5].

These are:

- A. Systematic Capability or Prior Use Justification for each device meets the SIL level of the SIF;
- B. Architecture Constraints (minimum redundancy requirements) are met; and
- C. a PFD_{AVG} / PFH calculation result is within the range of numbers given for the SIL level.

A. Systematic Capability (SC) is defined in IEC 61508:2010. The SC rating is a measure of design quality based upon the methods and techniques used to design and development a product. All devices in a SIF must have a SC rating equal or greater than the SIL level of the SIF. For example, a SIF is designed to meet SIL 3 with three pressure transmitters in a 2oo3 voting scheme. The transmitters have an SC2 rating. The design does not meet SIL 3. Alternatively, IEC 61511 allows the end user to perform a "Prior Use" justification. The end user evaluates the equipment to a given SIL level, documents the evaluation and takes responsibility for the justification.

B. Architecture constraints require certain minimum levels of redundancy. Different tables show different levels of redundancy for each SIL level. A table is chosen and redundancy is incorporated into the design [N6].

C. Probability of Failure on Demand (PFD_{AVG}) calculation uses several parameters, many of which are determined by the particular application and the operational policies of each site. Some parameters are product specific and the responsibility of the manufacturer. Those manufacturer specific parameters are given in this third party report.

A Probability of Failure on Demand (PFD_{AVG}) calculation must be done based on a number of variables including:

1. Failure rates of each product in the design including failure modes and any diagnostic coverage from automatic diagnostics (an attribute of the product given by this FMECA report);
2. Redundancy of devices including common cause failures (an attribute of the SIF design);
3. Proof Test Intervals (assignable by end user practices);
4. Mean Time to Restoration (an attribute of end user practices);
5. Proof Test Effectiveness; (an attribute of the proof test method used by the end user with an example given by this report);
6. Mission Time (an attribute of end user practices);
7. Proof Testing with process online or shutdown (an attribute of end user practices);
8. Proof Test Duration (an attribute of end user practices); and
9. Operational/Maintenance Capability (an attribute of end user practices).

The product manufacturer is responsible for the first variable. Most manufacturers use the *exida* FMEDA technique which is based on over 100 billion hours of field failure data in the process industries to predict these failure rates as seen in this report. A system designer chooses the second variable. All other variables are the responsibility of the end user site. The exSILentia® SILVer™ software considers all these variables and provides an effective means to calculate PFD_{AVG} for any given set of variables.

Simplified equations often account for only for first three variables. The equations published in IEC 61508-6, Annex B.3.2 [N1] cover only the first four variables. IEC 61508-6 is only an informative portion of the standard and as such gives only concepts, examples and guidance based on the idealistic assumptions stated. These assumptions often result in optimistic PFD_{AVG} calculations and have indicated SIL levels higher than reality. Therefore idealistic equations should not be used for actual SIF design verification.

All the variables listed above are important. As an example consider a high level protection SIF. The proposed design has a single SIL 3 certified level transmitter, a SIL 3 certified safety logic solver, and a single remote actuated valve consisting of a certified solenoid valve, certified scotch yoke actuator and a certified ball valve. Note that the numbers chosen are only an example and not the ones of the product described in this report.

Using exSILentia with the following variables selected to represent results from simplified equations:

- Mission Time = 5 years
- Proof Test Interval = 1 year for the sensor and final element, 5 years for the logic solver
- Proof Test Coverage = 100% (ideal and unrealistic but commonly assumed)
- Proof Test done with process offline

This results in a PFD_{AVG} of 6.82E-03 which meets SIL 2 with a risk reduction factor of 147. The subsystem PFD_{AVG} contributions are Sensor PFD_{AVG} = 5.55E-04, Logic Solver PFD_{AVG} = 9.55E-06, and Final Element PFD_{AVG} = 6.26E-03 (Figure 4).

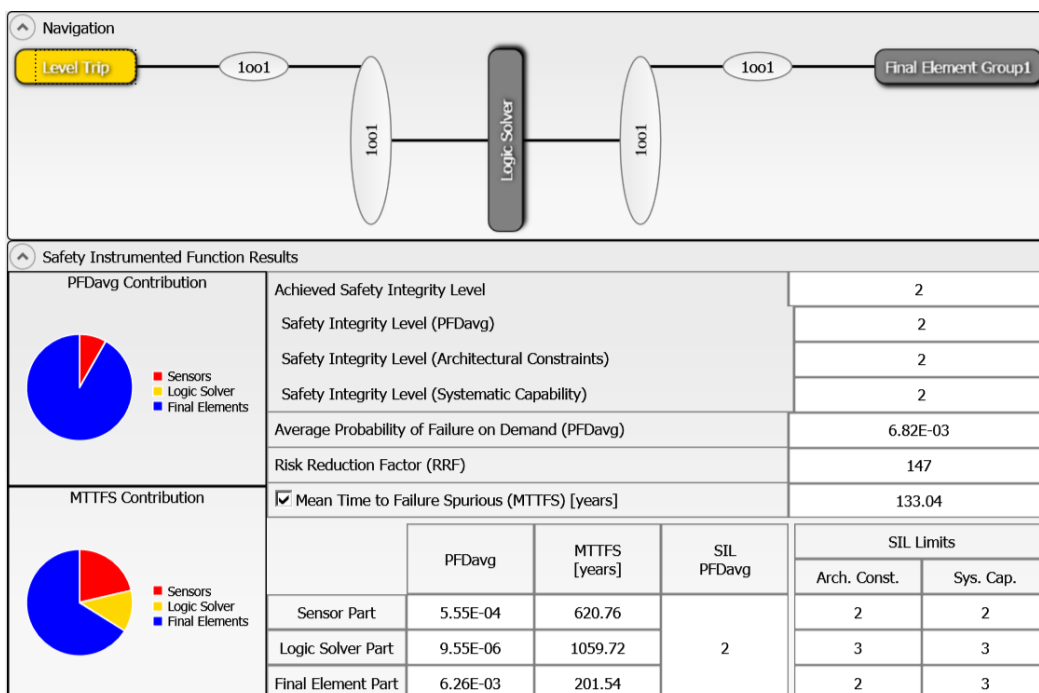

Figure 4: exSILentia results for idealistic variables

If the Proof Test Interval for the sensor and final element is increased in one year increments, the results are shown in Figure 5.

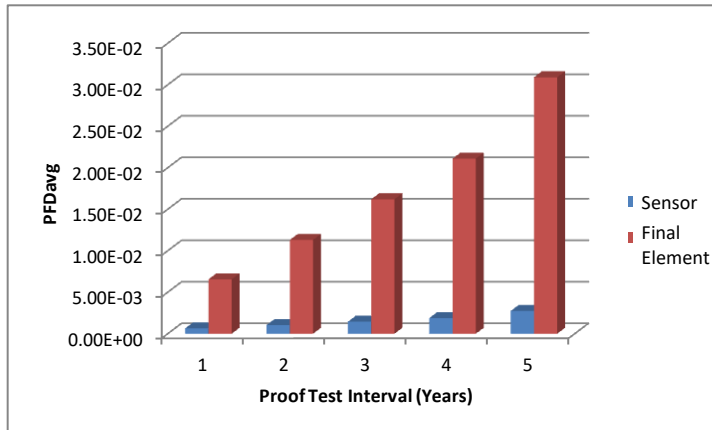

Figure 5: PFD_{AVG} versus Proof Test Interval

If a set of realistic variables for the same SIF are entered into the exSILentia software including:

- Mission Time = 25 years
- Proof Test Interval = 1 year for the sensor and final element, 5 years for the logic solver
- Proof Test Coverage = 90% for the sensor and 70% for the final element
- Proof Test Duration = 2 hours with process online.
- MTTR = 48 hours
- Maintenance Capability = Medium for sensor and final element, Good for logic solver

with all other variables remaining the same, the PFD_{AVG} for the SIF equals 5.76E-02 which barely meets SIL 1 with a risk reduction factor of 17. The subsystem PFD_{AVG} contributions are Sensor PFD_{AVG} = 2.77E-03, Logic Solver PFD_{AVG} = 1.14E-05, and Final Element PFD_{AVG} = 5.49E-02 (Figure 6).

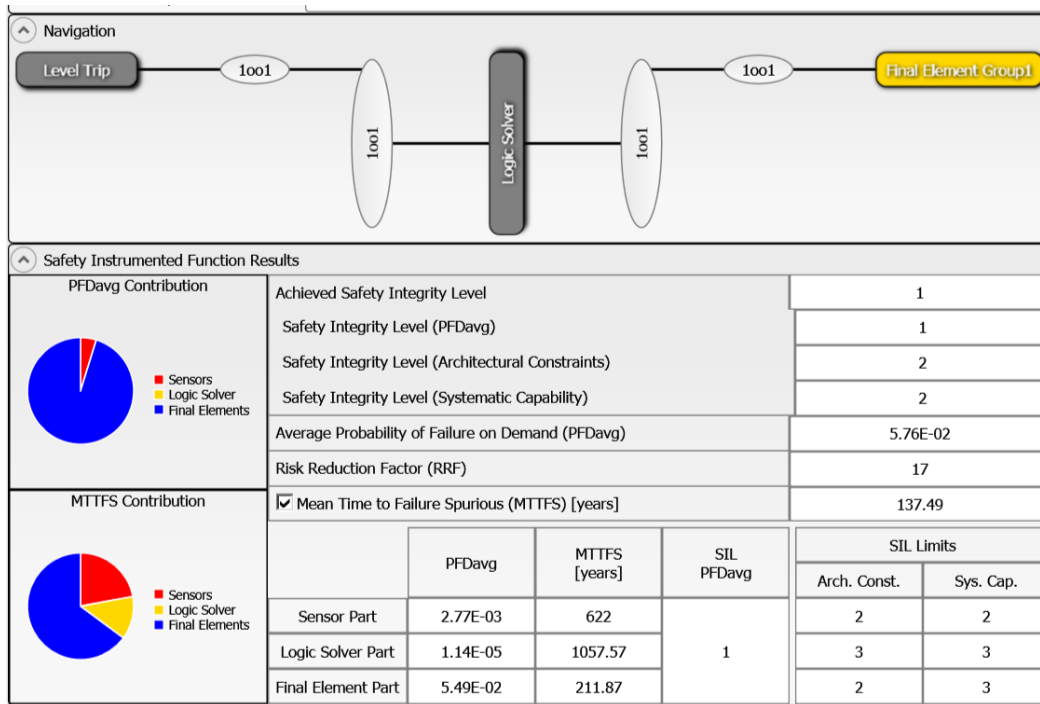

Figure 6: exSILentia results with realistic variables

It is clear that PFD_{AVG} results can change an entire SIL level or more when all critical variables are not used.

Appendix C: Using the FMEDA results

The Rosemount 248 and 644 Rail Mount Temperature Transmitters with RK and 4-20mA output together with a temperature sensing device become a temperature sensor assembly. Therefore, when using the results of this FMEDA in a SIL verification assessment, the failure rates and failure modes of the temperature sensing device must be considered.

In the following tables, resulting Safe Failure Fractions that are below 90% and therefore are not fulfilling the requirement of IEC61508-2:2010, Table 3 for complex devices with HFT = 0 for SIL2, are marked in red.

Appendix C.1: 248 RK, 644 RK with thermocouple

The failure mode distributions for thermocouples vary in published literature but there is strong agreement that open circuit or “burn-out” failure is the dominant failure mode. While some estimates put this failure mode at 99%+, a more conservative failure rate distribution suitable for SIS applications is shown in Table 9 and Table 10 when thermocouples are supplied with the Rosemount 248 and 644 Rail Mount Temperature Transmitters with RK and 4-20mA output. The drift failure mode is primarily due to T/C aging. The Rosemount 248 and 644 Rail Mount Temperature Transmitters with RK and 4-20mA output will detect a thermocouple burn-out failure and drive their output to the specified failure state.

Table 9 Typical failure rates for thermocouples (with extension wire)

<i>Thermocouple Failure Mode Distribution</i>	<i>Low Stress</i>	<i>High Stress</i>
Open Circuit (Burn-out)	900 FIT	18000 FIT
Short Circuit (Temperature measurement in error)	50 FIT	1000 FIT
Drift (Temperature measurement in error)	50 FIT	1000 FIT

Table 10 Typical failure rates for thermocouples (close coupled)

<i>Thermocouple Failure Mode Distribution</i>	<i>Low Stress</i>	<i>High Stress</i>
Open Circuit (Burn-out)	95 FIT	1900 FIT
Short Circuit (Temperature measurement in error)	4 FIT	80 FIT
Drift (Temperature measurement in error)	1 FIT	20 FIT

A complete temperature sensor assembly consisting of the Rosemount 248 and 644 Rail Mount Temperature Transmitters with RK and 4-20mA output and a temperature sensing device can be modeled by considering a series subsystem where a failure occurs if there is a failure in either component. For such a system, failure rates are added. Assuming that the Rosemount 248 and 644 Rail Mount Temperature Transmitters with RK and 4-20mA output will go to the pre-defined alarm state on detected failures of the thermocouple, the failure rate contribution for the thermocouple is:

Low stress environment (extension wire)	High stress environment (extension wire)
$\lambda_{dd} = 900 \text{ FIT}$	$\lambda_{dd} = 18000 \text{ FIT}$
$\lambda_{du} = 50 \text{ FIT} + 50 \text{ FIT} = 100 \text{ FIT}$	$\lambda_{du} = 1000 \text{ FIT} + 1000 \text{ FIT} = 2000 \text{ FIT}$

Low stress environment (close coupled)	High stress environment (close coupled)
$\lambda_{dd} = 95 \text{ FIT}$	$\lambda_{dd} = 1900 \text{ FIT}$
$\lambda_{du} = 4 \text{ FIT} + 1 \text{ FIT} = 5 \text{ FIT}$	$\lambda_{du} = 80 \text{ FIT} + 20 \text{ FIT} = 100 \text{ FIT}$

This results in a failure rate distribution and SFF to:

Table 11: 248 RK, 644 RK with thermocouple (low stress – with extension wire)

λ_{SD}	λ_{SU}	λ_{DD}	λ_{DU}	SFF
0 FIT	0 FIT	1353 FIT	128 FIT	91%

Table 12: 248 RK, 644 RK with thermocouple (low stress – close coupled)

λ_{SD}	λ_{SU}	λ_{DD}	λ_{DU}	SFF
0 FIT	0 FIT	548 FIT	33 FIT	94%

Table 13: 248 RK, 644 RK with thermocouple (high stress – with extension wire)

λ_{SD}	λ_{SU}	λ_{DD}	λ_{DU}	SFF
0 FIT	0 FIT	18453 FIT	2028 FIT	90%

Table 14: 248 RK, 644 RK with thermocouple (high stress – close coupled)

λ_{SD}	λ_{SU}	λ_{DD}	λ_{DU}	SFF
0 FIT	0 FIT	2353 FIT	128 FIT	94%

Appendix C.2: 248 RK, 644 RK with RTD

The failure mode distribution for an RTD also depends on the application with the key variables being stress level, RTD wire length and RTD type (2/3 wire or 4 wire). The key stress variables are high vibration and frequent temperature cycling as these are known to cause cracks in the substrate leading to broken lead connection welds. Failure rate distributions are shown in Table 15 to Table 18. The Rosemount 248 and 644 Rail Mount Temperature Transmitters with RK and 4-20mA output will detect open circuit, short circuit and a certain percentage of drift RTD failures and drive their output to the specified failure state.

Table 15 Typical failure rates for 4-Wire RTDs (with extension wire)

RTD Failure Mode Distribution	Low Stress	High Stress
Open Circuit (Burn-out)	410 FIT	8200 FIT
Short Circuit (Temperature measurement in error)	20 FIT	400 FIT
Drift (Temperature Measurement in error)	70 FIT ³¹	1400 FIT ³²

Table 16 Typical failure rates for 4-Wire RTDs (close coupled)

RTD Failure Mode Distribution	Low Stress	High Stress
Open Circuit (Burn-out)	41,5 FIT	830 FIT
Short Circuit (Temperature measurement in error)	2,5 FIT	50 FIT
Drift (Temperature Measurement in error)	6 FIT ³³	120 FIT ³⁴

Table 17 Typical failure rates for 2/3-Wire RTDs (with extension wire)

RTD Failure Mode Distribution	Low Stress	High Stress
Open Circuit (Burn-out)	370,5 FIT	7410 FIT
Short Circuit (Temperature measurement in error)	9,5 FIT	190 FIT
Drift (Temperature Measurement in error)	95 FIT	1900 FIT

Table 18 Typical failure rates for 2/3-Wire RTDs (close coupled)

RTD Failure Mode Distribution	Low Stress	High Stress
Open Circuit (Burn-out)	37,92 FIT	758,4 FIT
Short Circuit (Temperature measurement in error)	1,44 FIT	28,8 FIT
Drift (Temperature Measurement in error)	8,64 FIT	172,8 FIT

A complete temperature sensor assembly consisting of the Rosemount 248 and 644 Rail Mount Temperature Transmitters with RK and 4-20mA output and a temperature sensing device can be modeled by considering a series subsystem where a failure occurs if there is a failure in either component. For such a system, failure rates are added. Assuming that the Rosemount 248 and 644 Rail Mount Temperature Transmitters with RK and 4-20mA output will go to the pre-defined alarm state on a detected failure of the RTD, the failure rate contribution for the RTD is:

³¹ It is assumed that 65 FIT are detectable if the 4-wire RTD is correctly used.

³² It is assumed that 1300 FIT are detectable if the 4-wire RTD is correctly used.

³³ It is assumed that 3.5 FIT are detectable if the 4-wire RTD is correctly used.

³⁴ It is assumed that 70 FIT are detectable if the 4-wire RTD is correctly used.

4-wire RTD with extension wire:

Low stress environment	High stress environment
$\lambda_{dd} = 410 \text{ FIT} + 20 \text{ FIT} + 65 \text{ FIT} = 495 \text{ FIT}$	$\lambda_{dd} = 8200 \text{ FIT} + 400 \text{ FIT} + 1300 \text{ FIT} = 9900 \text{ FIT}$
$\lambda_{du} = 5 \text{ FIT}$	$\lambda_{du} = 100 \text{ FIT}$

4-wire RTD close coupled:

Low stress environment	High stress environment
$\lambda_{dd} = 41.5 \text{ FIT} + 2.5 \text{ FIT} + 3.5 \text{ FIT} = 47.5 \text{ FIT}$	$\lambda_{dd} = 830 \text{ FIT} + 50 \text{ FIT} + 70 \text{ FIT} = 950 \text{ FIT}$
$\lambda_{du} = 2.5 \text{ FIT}$	$\lambda_{du} = 50 \text{ FIT}$

2/3-wire RTD with extension wire:

Low stress environment	High stress environment
$\lambda_{dd} = 370.5 \text{ FIT} + 9.5 \text{ FIT} = 380 \text{ FIT}$	$\lambda_{dd} = 7410 \text{ FIT} + 190 \text{ FIT} = 7600 \text{ FIT}$
$\lambda_{du} = 95 \text{ FIT}$	$\lambda_{du} = 1900 \text{ FIT}$

2/3-wire RTD close coupled:

Low stress environment	High stress environment
$\lambda_{dd} = 37.92 \text{ FIT} + 1.44 \text{ FIT} = 39.36 \text{ FIT}$	$\lambda_{dd} = 758.4 \text{ FIT} + 28.8 \text{ FIT} = 787.2 \text{ FIT}$
$\lambda_{du} = 8.64 \text{ FIT}$	$\lambda_{du} = 172.8 \text{ FIT}$

This results in a failure rate distribution and SFF to:

Table 19: 248 RK, 644 RK with 4-wire RTD (low stress – with extension wire)

λ_{SD}	λ_{SU}	λ_{DD}	λ_{DU}	SFF
0 FIT	0 FIT	948 FIT	33FIT	96%

Table 20: 248 RK, 644 RK with 4-wire RTD (low stress – close coupled)

λ_{SD}	λ_{SU}	λ_{DD}	λ_{DU}	SFF
0 FIT	0 FIT	500 FIT	31 FIT	94%

Table 21: 248 RK, 644 RK with 4-wire RTD (high stress – with extension wire)

λ_{SD}	λ_{SU}	λ_{DD}	λ_{DU}	SFF
0 FIT	0 FIT	10353 FIT	128 FIT	98%

Table 22: 248 RK, 644 RK with 4-wire RTD (high stress – close coupled)

λ_{SD}	λ_{SU}	λ_{DD}	λ_{DU}	SFF
0 FIT	0 FIT	1403 FIT	78 FIT	94%

Table 23: 248 RK, 644 RK with 2/3-wire RTD (low stress – with extension wire)

λ_{SD}	λ_{SU}	λ_{DD}	λ_{DU}	SFF
0 FIT	0 FIT	833 FIT	123 FIT	87%

Table 24: 248 RK, 644 RK with 2/3-wire RTD (low stress – close coupled)

λ_{SD}	λ_{SU}	λ_{DD}	λ_{DU}	SFF
0 FIT	0 FIT	492 FIT	37 FIT	93%

Table 25: 248 RK, 644 RK with 2/3-wire RTD (high stress – with extension wire)

λ_{SD}	λ_{SU}	λ_{DD}	λ_{DU}	SFF
0 FIT	0 FIT	8053 FIT	1928 FIT	80%

Table 26: 248 RK, 644 RK with 2/3-wire RTD (high stress – close coupled)

λ_{SD}	λ_{SU}	λ_{DD}	λ_{DU}	SFF
0 FIT	0 FIT	1240 FIT	201 FIT	86%

Appendix C.3: 248 RK, 644 RK in dual mode (TC, RTD or mixed sensor types)

This appendix shows the failure rates when the Rosemount 248 and 644 Rail Mount Temperature Transmitters with RK and 4-20mA output is used in “dual mode” with two temperature sensing devices connected to it.

To obtain the overall failure rates of the sensor assembly, use the failure rates of the Rosemount 248 and 644 Rail Mount Temperature Transmitters with RK and 4-20mA output for dual mode and add failure rates of both temperature sensing devices. “Dual mode” indicates that two temperature sensing devices are combined to obtain one measurement value (e.g. the difference of two temperatures). The failure rates of both temperature sensing devices contribute fully to the overall failure rate and therefore have to be added both.

Table 27: 248 RK, 644 RK with two thermocouples (low stress – with extension wire); dual mode

λ_{SD}	λ_{SU}	λ_{DD}	λ_{DU}	SFF
0 FIT	0 FIT	2273 FIT	234 FIT	90%

Table 28: 248 RK, 644 RK with two thermocouples (low stress – close coupled); dual mode

λ_{SD}	λ_{SU}	λ_{DD}	λ_{DU}	SFF
0 FIT	0 FIT	663 FIT	44 FIT	93%

Table 29: 248 RK, 644 RK with two thermocouples (high stress – with extension wire); dual mode

λ_{SD}	λ_{SU}	λ_{DD}	λ_{DU}	SFF
0 FIT	0 FIT	36473 FIT	4034 FIT	90%

Table 30: 248 RK, 644 RK with two thermocouples (high stress – close coupled), dual mode

λ_{SD}	λ_{SU}	λ_{DD}	λ_{DU}	SFF
0 FIT	0 FIT	4273	234	94%

Table 31: 248 RK, 644 RK with two 2/3-wire RTD (low stress – with extension wire), dual mode

λ_{SD}	λ_{SU}	λ_{DD}	λ_{DU}	SFF
0 FIT	0 FIT	1233 FIT	224 FIT	85%

Table 32: 248 RK, 644 RK with two 2/3-wire RTD (low stress – close coupled) , dual mode

λ_{SD}	λ_{SU}	λ_{DD}	λ_{DU}	SFF
0 FIT	0 FIT	552 FIT	52 FIT	91%

Table 33: 248 RK, 644 RK with two 2/3-wire RTD (high stress – with extension wire) , dual mode

λ_{SD}	λ_{SU}	λ_{DD}	λ_{DU}	SFF
0 FIT	0 FIT	15673 FIT	3834 FIT	80%

Table 34: 248 RK, 644 RK with two 2/3-wire RTD (high stress – close coupled) , dual mode

λ_{SD}	λ_{SU}	λ_{DD}	λ_{DU}	SFF
0 FIT	0 FIT	2047 FIT	380 FIT	84%

Table 35: 248 RK, 644 RK with two 4-wire RTD (low stress – with extension wire), dual mode

λ_{SD}	λ_{SU}	λ_{DD}	λ_{DU}	SFF
0 FIT	0 FIT	1463 FIT	44 FIT	97%

Table 36: 248 RK, 644 RK with two 4-wire RTD (low stress – close coupled), dual mode

λ_{SD}	λ_{SU}	λ_{DD}	λ_{DU}	SFF
0 FIT	0 FIT	568 FIT	39 FIT	94%

Table 37: 248 RK, 644 RK with two 4-wire RTD (high stress – with extension wire), dual mode

λ_{SD}	λ_{SU}	λ_{DD}	λ_{DU}	SFF
0 FIT	0 FIT	20273 FIT	234 FIT	98%

Table 38: 248 RK, 644 RK w two 4-wire RTD (high stress – close coupled), dual mode

λ_{SD}	λ_{SU}	λ_{DD}	λ_{DU}	SFF
0 FIT	0 FIT	2373 FIT	134 FIT	94%

Table 39: 248 RK, 644 RK with TC and 2/3-wire RTD (low stress – with extension wire), dual mode

λ_{SD}	λ_{SU}	λ_{DD}	λ_{DU}	SFF
0 FIT	0 FIT	1753 FIT	229 FIT	88%

Table 40: 248 RK, 644 RK with TC and 2/3-wire RTD (low stress – close coupled), dual mode

λ_{SD}	λ_{SU}	λ_{DD}	λ_{DU}	SFF
0 FIT	0 FIT	607 FIT	142 FIT	81%

Table 41: 248 RK, 644 RK with TC and 2/3-wire RTD (high stress – with extension wire), dual mode

λ_{SD}	λ_{SU}	λ_{DD}	λ_{DU}	SFF
0 FIT	0 FIT	26073 FIT	3934 FIT	86%

Table 42: 248 RK, 644 RK with TC and 2/3-wire RTD (high stress – close coupled), dual mode

λ_{SD}	λ_{SU}	λ_{DD}	λ_{DU}	SFF
0 FIT	0 FIT	3160 FIT	2187 FIT	59%

Table 43: 248 RK, 644 RK with TC and 4-wire RTD (low stress – with extension wire), dual mode

λ_{SD}	λ_{SU}	λ_{DD}	λ_{DU}	SFF
0 FIT	0 FIT	1868 FIT	89 FIT	95%

Table 44: 248 RK, 644 RK with TC and 4-wire RTD (low stress – close coupled), dual mode

λ_{SD}	λ_{SU}	λ_{DD}	λ_{DU}	SFF
0 FIT	0 FIT	615 FIT	38 FIT	94%

Table 45: 248 RK, 644 RK with TC and 4-wire RTD (high stress – with extension wire), dual mode

λ_{SD}	λ_{SU}	λ_{DD}	λ_{DU}	SFF
0 FIT	0 FIT	28373 FIT	1134 FIT	96%

Table 46: 248 RK, 644 RK with TC and 4-wire RTD (high stress – close coupled), dual mode

λ_{SD}	λ_{SU}	λ_{DD}	λ_{DU}	SFF
0 FIT	0 FIT	3323 FIT	104 FIT	97%

Table 47: 248 RK, 644 RK with 2/3-wire and 4-wire RTD (low stress – with extension wire), dual mode

λ_{SD}	λ_{SU}	λ_{DD}	λ_{DU}	SFF
0 FIT	0 FIT	1348 FIT	134 FIT	90%

Table 48: 248 RK, 644 RK with 2/3-wire and 4-wire RTD (low stress – close coupled), dual mode

λ_{SD}	λ_{SU}	λ_{DD}	λ_{DU}	SFF
0 FIT	0 FIT	560 FIT	46 FIT	92%

Table 49: 248 RK, 644 RK with 2/3-wire and 4-wire RTD (high stress – with extension wire), dual mode

λ_{SD}	λ_{SU}	λ_{DD}	λ_{DU}	SFF
0 FIT	0 FIT	17973 FIT	2034 FIT	89%

Table 50: 248 RK, 644 RK with 2/3-wire and 4-wire RTD (high stress – close coupled), dual mode

λ_{SD}	λ_{SU}	λ_{DD}	λ_{DU}	SFF
0 FIT	0 FIT	2210 FIT	257 FIT	89%

Appendix C.4: 248 RK, 644 RK in redundant mode (TC, RTD or mixed) with drift monitoring

This appendix shows the failure rates when the Rosemount 248 and 644 Rail Mount Temperature Transmitters with RK and 4-20mA output is used in redundant mode with two temperature sensing devices connected to it.

To obtain the overall failure rates of the sensor assembly, use the failure rates of the Rosemount 248 and 644 Rail Mount Temperature Transmitters with RK and 4-20mA output for redundant mode and add failure rates of both temperature sensing devices. The temperature sensing device failure rates should be adjusted to reflect the additional coverage (95%) on the normally undetected failures provided by the drift alarm.

Table 51: 248 RK, 644 RK with two thermocouples (low stress – with extension wire)

λ_{SD}	λ_{SU}	λ_{DD}	λ_{DU}	SFF
0 FIT	0 FIT	2486 FIT	33 FIT	98%

Table 52: 248 RK, 644 RK with two thermocouples (low stress – close coupled)

λ_{SD}	λ_{SU}	λ_{DD}	λ_{DU}	SFF
0 FIT	0 FIT	695 FIT	24 FIT	97%

Table 53: 248 RK, 644 RK with two thermocouples (high stress – with extension wire)

λ_{SD}	λ_{SU}	λ_{DD}	λ_{DU}	SFF
0 FIT	0 FIT	40296 FIT	223 FIT	99%

Table 54: 248 RK, 644 RK with two thermocouples (high stress – close coupled)

λ_{SD}	λ_{SU}	λ_{DD}	λ_{DU}	SFF
0 FIT	0 FIT	4486 FIT	33 FIT	99%

Table 55: 248 RK, 644 RK with two 2/3-wire RTDs (low stress – with extension wire)

λ_{SD}	λ_{SU}	λ_{DD}	λ_{DU}	SFF
0 FIT	0 FIT	1436 FIT	33 FIT	98%

Table 56: 248 RK, 644 RK with two 2/3-wire RTDs (low stress – close coupled)

λ_{SD}	λ_{SU}	λ_{DD}	λ_{DU}	SFF
0 FIT	0 FIT	591 FIT	24 FIT	96%

Table 57: 248 RK, 644 RK with two 2/3-wire RTDs (high stress – with extension wire)

λ_{SD}	λ_{SU}	λ_{DD}	λ_{DU}	SFF
0 FIT	0 FIT	19306 FIT	213 FIT	99%

Table 58: 248 RK, 644 RK with two 2/3-wire RTDs (high stress – close coupled)

λ_{SD}	λ_{SU}	λ_{DD}	λ_{DU}	SFF
0 FIT	0 FIT	2398 FIT	40 FIT	98%

Table 59: 248 RK, 644 RK with two 4-wire RTDs (low stress – with extension wire)

λ_{SD}	λ_{SU}	λ_{DD}	λ_{DU}	SFF
0 FIT	0 FIT	1495 FIT	24 FIT	98%

Table 60: 248 RK, 644 RK with two 4-wire RTDs (low stress – close coupled)

λ_{SD}	λ_{SU}	λ_{DD}	λ_{DU}	SFF
0 FIT	0 FIT	595 FIT	23 FIT	96%

Table 61: 248 RK, 644 RK with two 4-wire RTDs (high stress – with extension wire)

λ_{SD}	λ_{SU}	λ_{DD}	λ_{DU}	SFF
0 FIT	0 FIT	20486 FIT	33 FIT	99%

Table 62: 248 RK, 644 RK with two 4-wire RTDs (high stress – close coupled)

λ_{SD}	λ_{SU}	λ_{DD}	λ_{DU}	SFF
0 FIT	0 FIT	2491 FIT	28 FIT	98%

Table 63: 248 RK, 644 RK with thermocouple and 2/3-wire RTD (low stress – with extension wire)

λ_{SD}	λ_{SU}	λ_{DD}	λ_{DU}	SFF
0 FIT	0 FIT	1961 FIT	33 FIT	98%

Table 64: 248 RK, 644 RK with thermocouple and 2/3-wire RTD (low stress – close coupled)

λ_{SD}	λ_{SU}	λ_{DD}	λ_{DU}	SFF
0 FIT	0 FIT	634 FIT	28 FIT	95%

Table 65: 248 RK, 644 RK with thermocouple and 2/3-wire RTD (high stress – with extension wire)

λ_{SD}	λ_{SU}	λ_{DD}	λ_{DU}	SFF
0 FIT	0 FIT	29801 FIT	218 FIT	99%

Table 66: 248 RK, 644 RK with thermocouple and 2/3-wire RTD (high stress – close coupled)

λ_{SD}	λ_{SU}	λ_{DD}	λ_{DU}	SFF
0 FIT	0 FIT	3442 FIT	1301 FIT	96%

Table 67: 248 RK, 644 RK with thermocouple and 4-wire RTD (low stress – with extension wire)

λ_{SD}	λ_{SU}	λ_{DD}	λ_{DU}	SFF
0 FIT	0 FIT	1990 FIT	28 FIT	98%

Table 68: 248 RK, 644 RK with thermocouple and 4-wire RTD (low stress – close coupled)

λ_{SD}	λ_{SU}	λ_{DD}	λ_{DU}	SFF
0 FIT	0 FIT	645 FIT	28 FIT	95%

Table 69: 248 RK, 644 RK with thermocouple and 4-wire RTD (high stress – with extension wire)

λ_{SD}	λ_{SU}	λ_{DD}	λ_{DU}	SFF
0 FIT	0 FIT	30391 FIT	128 FIT	99%

Table 70: 248 RK, 644 RK with thermocouple and 4-wire RTD (high stress – close coupled)

λ_{SD}	λ_{SU}	λ_{DD}	λ_{DU}	SFF
0 FIT	0 FIT	3488 FIT	125 FIT	96%