2000 Series Installation Guide

EDP 100-214-226
Rev. 10 Software Version 9.x

BRANSON Ultrasonics Corporation
41 Eagle Road
Danbury, Connecticut 06813-1961 U.S.A.
(203) 796-0400
<http://www.bransonultrasonics.com>

Manual Change Information

At Branson, we strive to maintain our position as the leader in ultrasonics plastics joining, cleaning and related technologies by continually improving our circuits and components in our equipment. These improvements are incorporated as soon as they are developed and thoroughly tested.

Information concerning any improvements will be added to the appropriate technical documentation at its next revision and printing. Therefore, when requesting service assistance for specific units, note the Revision information found on the cover of this document, and refer to the printing date which appears at the bottom of this page.

Copyright



NOTE

Loctite is a registered trademark of Henkel Corporation U.S.A. Other trademarks and service marks mentioned herein are held by their respective owners.

2000 Series Installation Guide

Foreword

Congratulations on your choice of a Branson Ultrasonics Corporation system!

The Branson 2000-Series system is process equipment for the joining of plastic parts using ultrasonic energy. It is the newest generation of product using this sophisticated technology for a variety of customer applications. This Instruction Manual is part of the documentation set for this system, and should be kept with the equipment.

Thank you for choosing Branson!

Introduction

This manual is arranged into several structured chapters which will help you find the information you may need to know to safely handle, install, set up, program, operate, and/or maintain this product. Please refer to the Table of Contents and/or the Index of this manual to find the information you may be looking for. In the event you require additional assistance or information, please contact our Product Support department (see page 52 for information on how to contact them) or your local Branson representative.

Table of Contents

- About this Installation Guide** - - - - - 1
- Safety First** - - - - - 2
- Handling and Unpacking** - - - - - 3
 - Unpack the Power Supply - - - - - 3
 - Unpack the Stand or Actuator - - - - - 3
 - Stand (actuator on a base) - - - - - 4
 - Stand (actuator on a hub) - - - - - 5
 - Actuator (alone) - - - - - 6
 - Take Inventory of Small Parts - - - - - 7
 - Cables - - - - - 8
- Installation Requirements** - - - - - 9
 - Location - - - - - 9
 - Environmental Specifications - - - - - 9
 - Electrical Input Power Ratings - - - - - 10
- Factory Air** - - - - - 17
 - Air Filter - - - - - 17
 - Pneumatic Tubing and Connectors - - - - - 17
 - Pneumatic Connections to Actuator ae/aed/aef - - - - - 18
 - Pneumatic Connections to Actuator ao/aod/rp - - - - - 18
 - Mounting the Stand (Actuator on Base) - - - - - 18
 - Leveling Fixture Setup - - - - - 19
 - Preliminary Setup - - - - - 19
 - Setup - - - - - 22
 - Horn, Part, and Fixture Alignment - - - - - 23
 - Mounting the Stand (Actuator on Hub-mounted column) - - - - - 24
 - Actuator (alone) - - - - - 25
 - Mount the Power Supply - - - - - 27
 - Interconnect between Power Supply and Actuator - - - - - 27
 - Input Power (Main) - - - - - 28
 - Output Power (RF Cable) - - - - - 29
- Start Switch Connection (Automation)** - - - - - 30

Serial (RS-232) Port Connector- - - - -	-31
Parallel Printer Connector - - - - -	-31
User I/O Interface - - - - -	-32
Input Power Plug- - - - -	-34
User I/O DIP Switch (SW1)- - - - -	-35
Guards and Safety Equipment - - - - -	-36
Emergency Stop Control - - - - -	-36
Rack Mount Installation- - - - - -	-38
Assemble the Acoustic Stack - - - - -	-40
For a 15 kHz System	
For a 20kHz System	
For a 30kHz System	
For a 40kHz System	
Stack Assembly Torque Tables- - - - -	-43
Connecting Tip to Horn- - - - -	-44
Installing the Ultrasonic Stack in the Actuator - - - - -	-44
15 kHz, 20 and 30 kHz Stacks - - - - -	-44
40 kHz Stacks- - - - -	-46
Mounting the Fixture on the Branson Base - - - - -	-47
Converter Duty Cycle and Cooling - - - - -	-48
Testing the Installation, 4 Line Display - - - - -	-50
Testing the Installation, Touch Screen - - - - -	-51

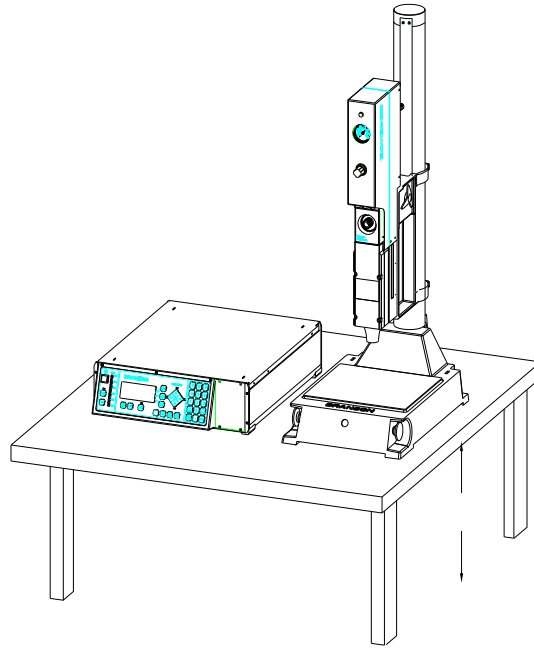

About this Installation Guide

This installation guide is to help the installer with the basic installation and setup of your new 2000-series welder. You will still need the product's manuals. This guide will bring the reader to the point at which the system is functionally "ready to weld".

Safety First

Branson is concerned for your safety and for the successful installation and operation of this system. Please read and heed all safety symbols listed in this guide and heed all safety signs on the products.



WARNING

Indicates a potentially hazardous situation which, if not avoided, could result in death or serious injury.



CAUTION

Indicates a potentially hazardous situation which, if not avoided, may result in minor or moderate injury.

CAUTION

Indicates a potential hazardous situation which, if not avoided, may result in property damage.



NOTE

A Note in the guide or manual contains important information that you should observe. It does not involve personal injury but may involve additional work or modification if you ignore it.

International safety labels are found on the power supply and the actuator as well. Those that are of importance during Installation of the system are identified in the figures in this guide and in the manuals.

Handling and Unpacking

If there are any visible signs of damage to the shipping containers or the product, or you later discover hidden damage, NOTIFY YOUR CARRIER IMMEDIATELY. Save the packing material.

1. Unpack the 2000-series components as soon as they arrive. Refer to the following procedures. Verify you have all of the equipment ordered. Some components are packed inside other boxes.
2. Inspect the controls, indicators, and surfaces for signs of damage.
3. Save all packing material, including the pallets and wood spacer blocks.

Unpack the Power Supply

Power supplies are shipped in a cardboard carton. It weighs approximately 40 lbs.

1. Open the box, remove the two foam top packing halves and lift the power supply out.
2. Remove the toolkit(s) and other components shipped with the power supply. These items may be shipped in small, separate boxes, or underneath the power supply in the box.
3. Save the packing material; evaluation systems will be returned using this packing material.

Unpack the Stand or Actuator

The stand (or actuator) is heavy and packed in a protective shipping container. The actuator toolkit is packed with the actuator. A booster, converter and other components may be packed inside the shipping container (depending on the equipment ordered).

- Stands are shipped on a wooden pallet with a cardboard box cover.
- Actuators (alone) are shipped in a rigid cardboard box using protective foam shells for support.

Figure 1 Linear Encoder is sensitive; Do Not Handle it!

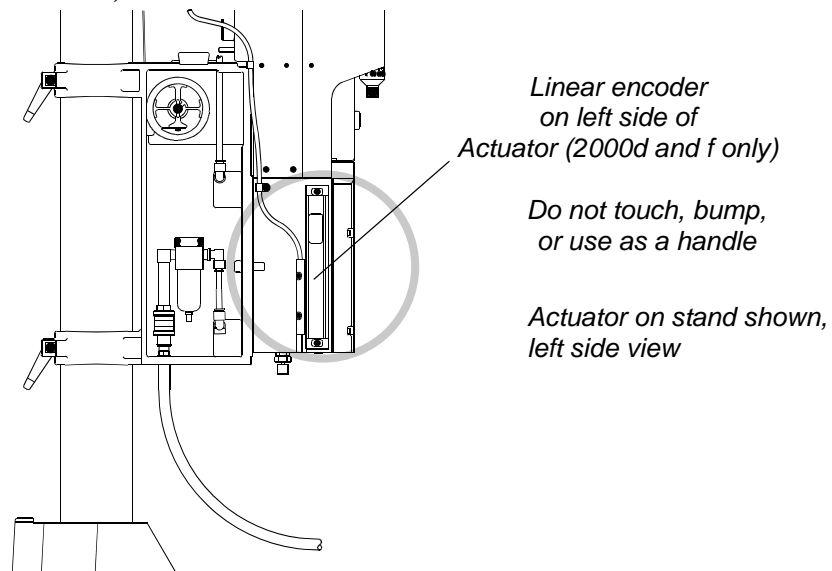

CAUTION

The linear encoder (on the left side of the actuator) is very sensitive. Do not use the linear encoder assembly as a hand-hold, allow no impact on it, and do not place any weight on it.

Depending on which one of the following options applies to you, unpack the Branson actuator assembly:

Stand (actuator on a base)



CAUTION

Heed the “This End Up” arrows and the “Open Top First” instructions. The packaging is designed to be removed from the assemblies from an upright orientation only.

Figure 2 Unpacking the Stand (Actuator on a Base); right-side view of Stand

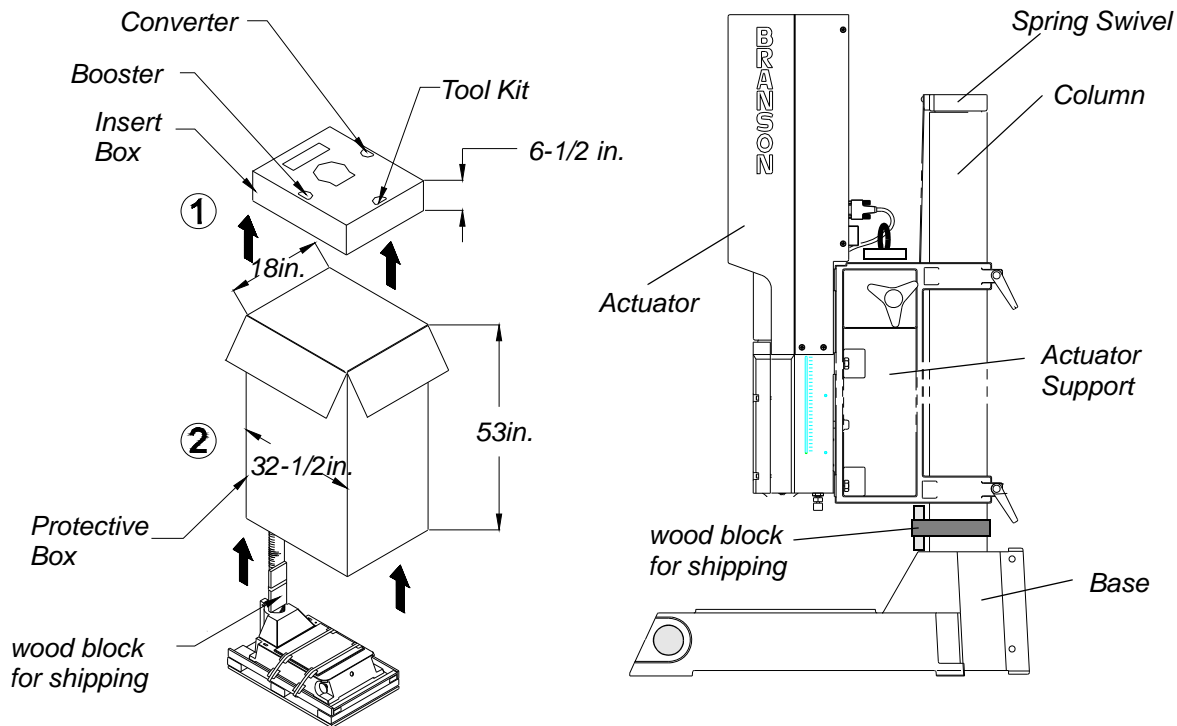

1. Move the shipping container close to the intended installation location, leave it on the floor.
2. Open the top of the box. Remove the insert from the top of the protective box, which may contain the booster, converter, and the toolkit.
3. Remove the staples at the bottom of the protective box. Lift the protective box off the pallet.



CAUTION

Column and column are under spring tension. Do NOT disassemble the column from the stand. Always keep the column support clamped together.



NOTE

When making height adjustments, carefully and slowly release the clamps to control the motion, and hold the stand to prevent sudden movements or injury.

4. Cut the two packing straps around the base and pallet. Pry off the two wooden shipping blocks (to the rear of the base) which prevent the base from sliding on the pallet.
5. The stand can now be moved into its desired location by sliding it off the pallet. Stands have a lifting hook for the use of overhead hoists to lift the assembly in place.
6. Remove the block of wood between the base and the column support by carefully loosening the two column clamps (allowing the actuator to rise slightly, but not allow sudden movements) and then cutting the shipping tape on the block of wood. **RETIGHTEN THE COLUMN CLAMPS.**
7. Unpack the toolkit from the insert box, and other parts (converter, booster, etc.) that may have shipped with the stand. Save the packing material.
8. Go to **Take Inventory of Small Parts.** See [Table 2](#).

Stand (actuator on a hub)

Figure 3 Unpacking the Stand (Actuator on a Hub); Hub shown separately

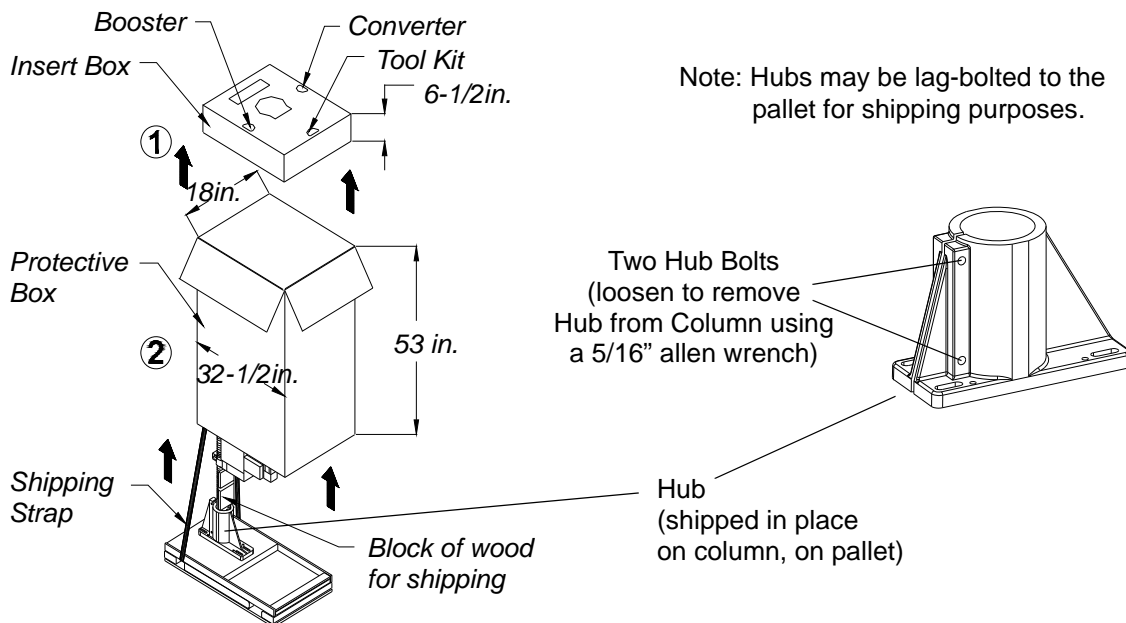

CAUTION

Heed the “This End Up” arrows and the “Open Top First” instructions. The packaging is designed to be removed from the assemblies from an upright orientation only.

1. Move the shipping container close to the intended installation location, leave it on the floor.
2. Cut the two vertical packing straps, and open the top of the box. Remove the insert from the top of the box, which can contain the booster, converter, and the toolkit. Set the insert box aside.
3. Remove the staples at the bottom of the protective box. Lift the protective box off the pallet. Flatten the box and lay it next to the pallet (you will lay the stand on it soon).



CAUTION

The unit may tip over. Stabilize the stand using the lifting hook or an assistant.

- Cut the packing strap securing the actuator support to the pallet.



CAUTION

Column and support are under spring tension. Do NOT disassemble the column from the stand. Always keep the column support clamped together.



NOTE

When making height adjustments, carefully and slowly release the clamps to control the motion, and hold the stand to prevent sudden movements or injury.

- Remove the block(s) of wood between the base and the support by slowly loosening the two column clamps (allowing the stand to rise slightly) and then cutting the shipping tape on the block of wood. **RETIGHTEN THE COLUMN CLAMPS.**
- Loosen the two hub bolts (for column clamping) on the hub.
- Lift the actuator and column from the pallet. Carefully lay the stand on its right side (**NOT ON THE SIDE WITH THE LINEAR ENCODER**, if present).
- Remove the hub from the pallet and set it aside. Some hubs are bolted to the pallet from the top.
- Unpack the converter, booster and toolkit from the insert box. Save the packing material, including the blocks of wood.
- Go to **Take Inventory of Small Parts**. See Table 2.

Actuator (alone)

The actuator, if shipped alone, is assembled and ready to install.



NOTE

In a custom installation, the actuator must be mounted on an I-beam or other rigid structure. The mounting surface must be flat within 0.004 in (0.1mm) Total Indicator Reading, in a tolerance zone of 16 x 3.5 in (410 x 90 mm).

Move the shipping container close to the intended installation location, leave it on the floor.

- Open the top of the cardboard box, remove the insert from the top of the box and set it aside.
- The tool kit, mounting bolts, and converter and/or booster are shipped with the actuator but in separate shipping box(es). Unpack the converter, booster, toolkit and bolts from their packages.
- Save the packing material.



NOTE

The packaging may also include the converter and/or booster, if ordered.

Figure 4 Ultrasonic Converter and Booster

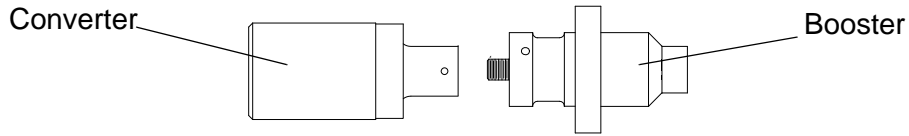

Table 1 Actuator Weights, Approximate (lbs)

Actuator Model	Actuator on a Base	Actuator on a Hub	Actuator Alone
ao	174	134	39
aod	176	136	40
ae	170	130	35
aed	172	132	36
aef	180	140	38

Take Inventory of Small Parts

Table 2 Small Parts Included (=x) with Power Supply and/or Actuator Assemblies

Part or Kit	2000 Power Supply				Actuator		
	15kHz	20kHz	30kHz	40kHz	Stand (Base)	Stand (Hub)	(alone)
T-Handle Wrench					x	x	x
Mylar Washer Kit	x	x	x				
Silicone Grease				x			
Actuator Mtg. Bolts							x
15kHz Spanners (2)	x						
20kHz Spanners (2)		x					
30kHz Spanners (2)			x				
40kHz Spanners (2)				x			
40kHz Sleeve					ordered part	ordered part	ordered part
40kHz Sleeve Spanner					ships w/ Sleeve	ships w/ Sleeve	ships w/ Sleeve
Fixture Bolts and Washer					x		
M8 Allen Wrench					x		
5/64 in. Allen Wrench*					x	x	x

i NOTE

Part numbers for spares are found in the Instruction Manuals.

*not used with 2000f actuator

Handling and Unpacking

Cables

Two cables connect the power supply and actuator: the actuator interface cable, and the RF cable. If the system is to be automated, you may also need a J911 start cable and a user I/O cable. Check your invoice for cable types and cable lengths.

Table 3 *List of Cables*

101-241-202	Remote Pneumatic (RP) Package Cable (J924), 8'
101-241-203	Actuator Interface, 8' (J925S)
101-241-204	Actuator Interface, 15'(J925S)
101-241-205	Actuator Interface, 25'(J925S)
101-241-206	Actuator Interface, 50'(J925S)
101-241-207	Alarm I/O, 8'(J957S)
101-241-208	Alarm I/O, 15'(J957S)
101-241-209	Alarm I/O, 25'(J957S)
101-241-258	Alarm I/O, 50'(J957S)
101-240-020	Start Cable (J911) 8' (req PLA)
101-240-015	Start Cable (J911) 15' (req PLA)
101-240-010	Start Cable (J911) 25' (req PLA)
101-240-168	Start Cable (J911) 50' (req PLA)
101-240-072	Start Cable (J913) 25' (no PLA req)
101-240-017	RF, non-CE - 8' (J931S)
101-240-012	RF, non-CE - 15' (J931S)
101-240-007	RF, non-CE - 25' (J931S) Note: Not for 30kHz or 40kHz systems
101-240-200	RF, non-CE - 50' (J931) Note: Not for 30kHz or 40kHz systems
101-240-034	RF, non CE - 8' (J 934)
101-240-035	RF, non CE - 15' (J934)
101-240-081	RF, non CE - 8' (J936S)
101-240-069	RF, non CE - 15' (J936S)
101-240-080	RF, non CE - 25' (J936S)
101-240-176	RF, CE - 8' (J931CS)
101-240-177	RF, CE - 15' (J931CS)
101-240-178	RF, CE - 25' (J931CS) Note: Not for 30kHz or 40kHz systems
101-240-199	RF, CE - 50' (J931C)
101-240-179	RF, CE - 8' (J934C)
101-240-188	RF, CE - 15' (J934C)
101-240-182	RF, CE - 20' (J934C)
100-246-630	Ground Detect Cable
100-143-043	Printer, 6'

CE and non CE cables are fabricated to different specifications. CE cables differ in that the pin distance and allowable insulation creepage is controlled to more exacting tolerances.

Installation Requirements

Location

The actuator or stand may be installed in a variety of positions. The stand (mounted on a base) is often manually operated, using its base-mounted start switches, and so is installed at a safe (being able to support at least 250 pounds) and comfortable workbench height (approximately 30-36 inches for seated operation, 36-42 for standing) with the operator sitting or standing in front of the system. Stands (on hubs) are designed for use in automated systems and may be manually or automatically loaded and unloaded.



WARNING

Stand may tip over if rotated around the axis of its column. Secure base or hub.



NOTE

The work surface on which a stand is installed must be sturdy enough to support it, and secure enough to not tip over when the stand is adjusted during installation or setup.

The power supply may be located up to 25 feet away for the 15kHz, (50' for 20kHz, 20' for 30kHz, and 15' for 40kHz models) from the actuator. The power supply must be accessible for user parameter changes and settings, and must be placed in a horizontal orientation for purposes of heat management. The power supply should be positioned so it does not draw in dust, dirt or material via its rear fans. See Figure 5 for a dimensional drawing. All dimensions are approximate and may vary between models.

Environmental Specifications

Table 4 *Environmental Specifications*

Environmental Concern	Acceptable Range
Humidity	30% to 95%, non-condensing
Ambient Operating Temperature	+5°C to +50°C (41°F to 122°F)
Storage / Shipping Temperature	-25°C to +55°C (-13°F to +131°F); Up to +70°C (+158°F) for 24 hours

Electrical Input Power Ratings

Plug the Power Supply into a single-phase, grounded, 3-wire, 50 or 60 Hz power source. Table 5 lists the current, fuse ratings and Plugs for the various models.

Table 5 *Input Power and Plug Requirements*

For 15 kHz models	3300 W 200V - 240V	19 Amp Max. @ 200V / 20 Amp fuse	NEMA L6-20P Plug
For 20 kHz models	1100 W 200V - 240V	7 Amp Max. @ 200V / 20 Amp fuse	NEMA L6-20P Plug
	1100 W 100V - 120V	13 Amp Max. @ 100V / 20 Amp fuse	NEMA 5-15P Plug
	2200 W 200V - 240V	13 Amp Max. @ 200V / 20 Amp fuse	NEMA L6-20P Plug
	3300 W 200V - 240V	19 Amp Max. @ 200V / 20 Amp fuse	NEMA L6-20P Plug
	4000 W 220V - 240V	21 Amp Max. @ 220V / 25 Amp fuse	NEMA L6-20P Plug
For 30 kHz models	1500 W 100V - 120V*	20 Amp Max. @ 100V / 20 Amp fuse	NEMA 5-20P Plug
	1500 W 200V - 240V	10 Amp Max. @ 200V / 20 Amp fuse	NEMA L6-20P Plug
For 40 kHz models	400 W 200V - 240V	3 Amp Max. @ 200V / 20 Amp fuse	NEMA L6-20P Plug
	400 W 100V - 120V	5 Amp Max. @ 100V / 20 Amp fuse	NEMA 5-15P Plug
	800 W 200V - 240V	5 Amp Max. @ 200V / 20 Amp fuse	NEMA L6-20P Plug
	800 W 100V - 120V	10 Amp Max. @ 100V / 20 Amp fuse	NEMA 5-15P Plug
For 60 kHz model	200 W 100V - 120 V	3 Amp Max. @ 100V / 3 Amp fuse	NEMA 5-15P Plug

* requires a specific 20 amp 120V receptacle

The voltages shown in the above table have the following operational tolerances:

100V - 120V nominal, 90 - 132 operational

200V - 240V nominal, 180 - 253 operational

Figure 5 VFD 4 Line Display Power Supply Dimensional Drawing

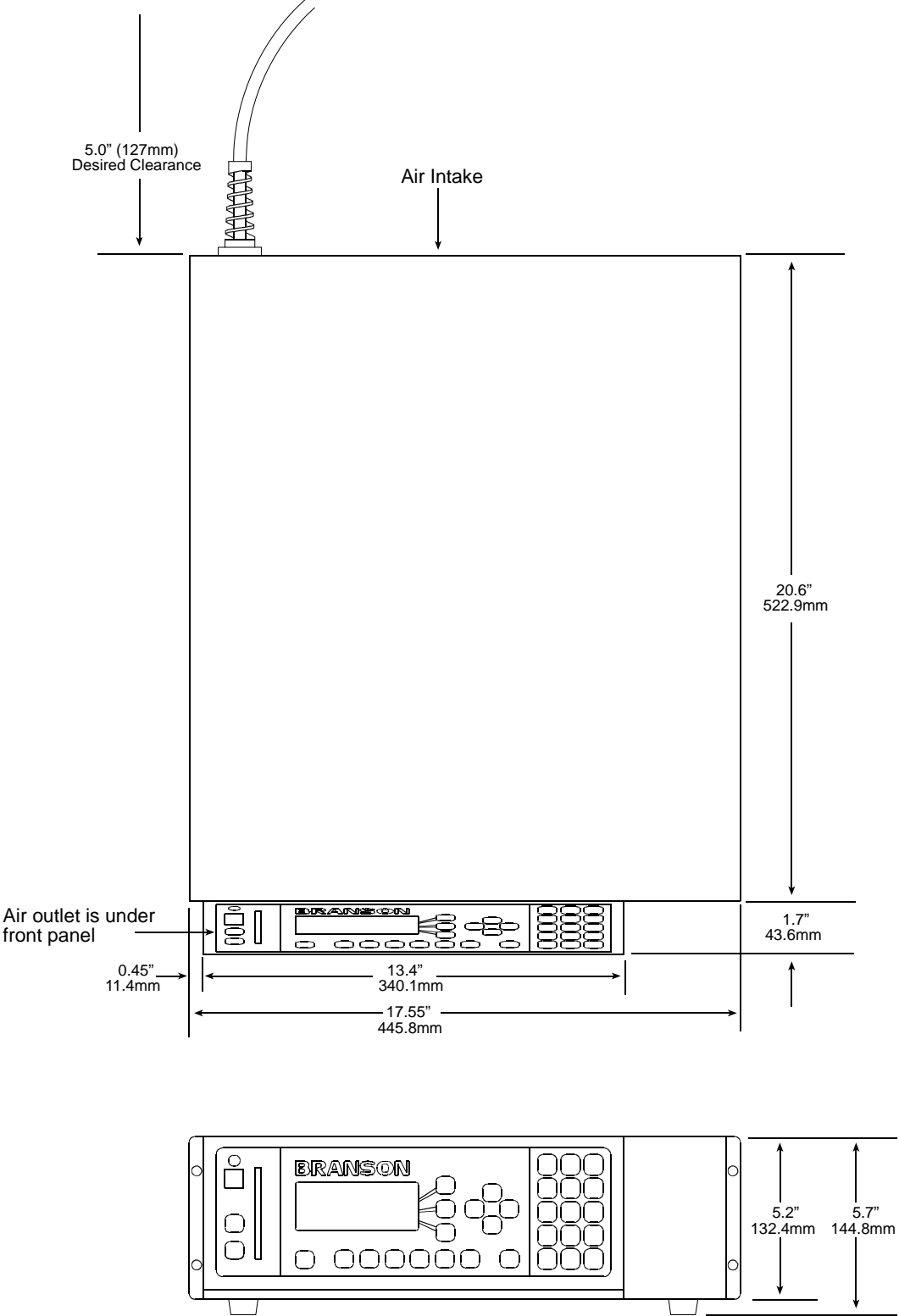

Figure 6 Touch Screen Power Supply Dimensional Diagram

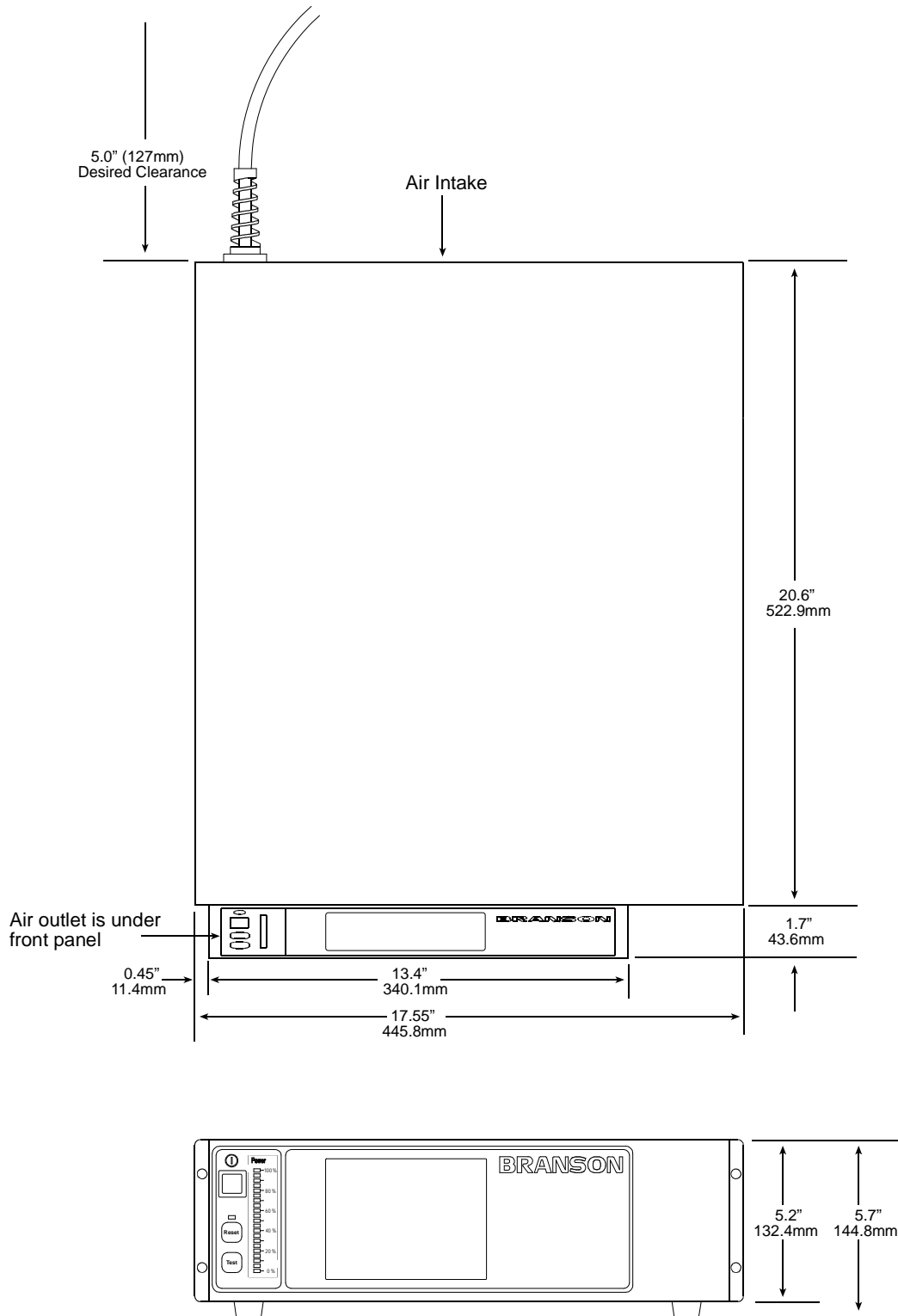
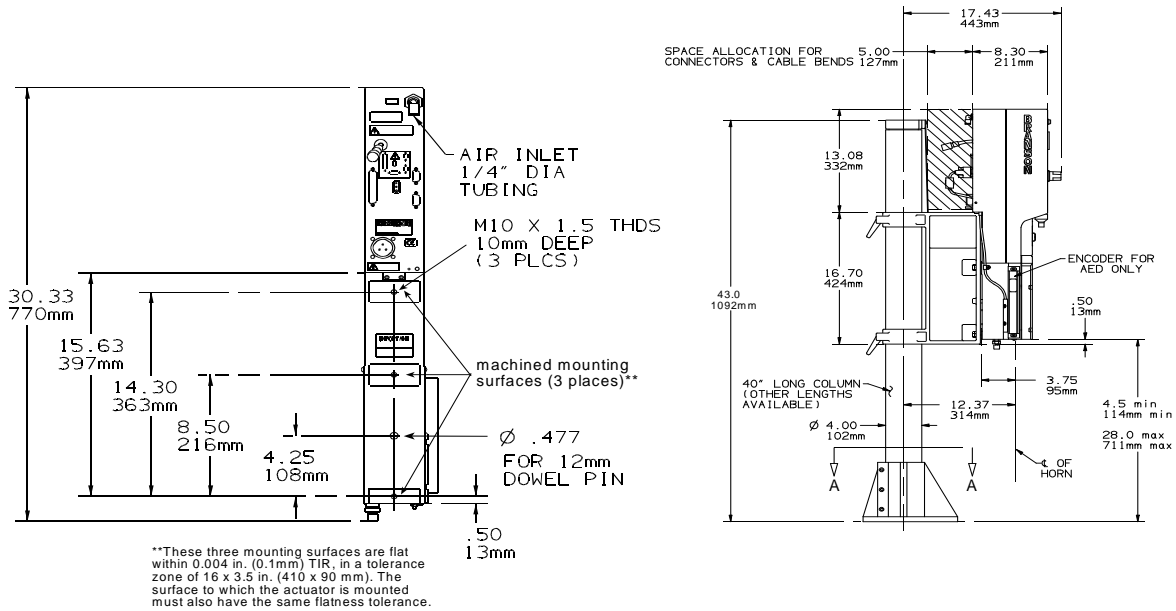
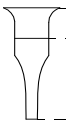



Figure 7 ae/aed Actuator Dimensional Drawing



	FREQUENCY			DIMENSIONS SHOWN ARE APPROXIMATE TO ALLOW FOR DIFFERENT BOOSTER GAIN HORN DESIGN, MATERIAL, AND TUNING. ALL HORN DIMENSIONS ARE FOR 1/2 WAVE DESIGNS. ALLOW FOR ADJUSTABILITY AND POTENTIAL TOOLING CHANGE.
	20KHz	30KHz	40KHz	
	2.12 to 2.75 54 mm to 70 mm	1.30 to 1.54 33 mm to 39 mm	0.69 to 0.94 18 mm to 24 mm	
	5 to 5.50 127 mm to 140 mm	2.97 to 3.80 75 mm to 97 mm	2.5 to 2.75 64 mm to 70 mm	

HORN WIDTH AND LENGTH WILL VARY WITH EACH DESIGN

Figure 8 aef Actuator Dimensional Drawing

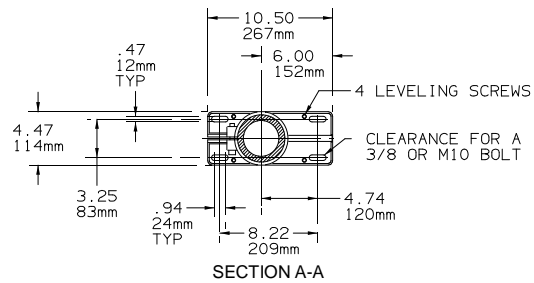
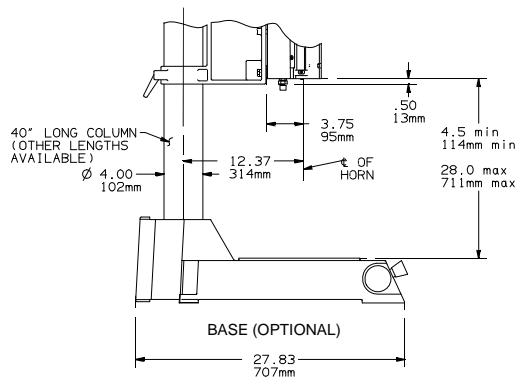
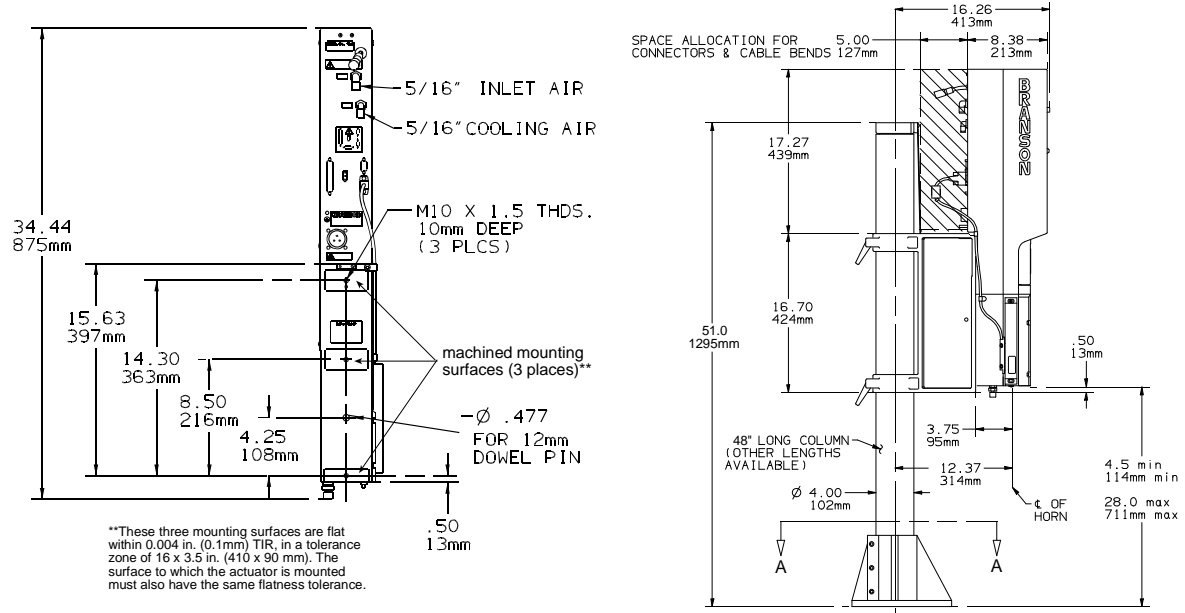

	FREQUENCY			DIMENSIONS SHOWN ARE APPROXIMATE TO ALLOW FOR DIFFERENT BOOSTER GAIN HORN DESIGN, MATERIAL, AND TUNING. ALL HORN DIMENSIONS ARE FOR 1/2 WAVE DESIGNS. ALLOW FOR ADJUSTABILITY AND POTENTIAL TOOLING CHANGE.
	20KHz	30KHz	40KHz	
	2.12 to 2.75 54 mm 70 mm	1.30 to 1.54 33 mm 39 mm	0.69 to 0.94 18 mm 24 mm	
	5 to 5.50 127 mm 140 mm	2.97 to 3.80 75 mm 97 mm	2.5 to 2.75 64 mm 70 mm	

HORN WIDTH AND LENGTH WILL VARY WITH EACH DESIGN

Figure 9 ao/aod Actuator Dimensional Drawing

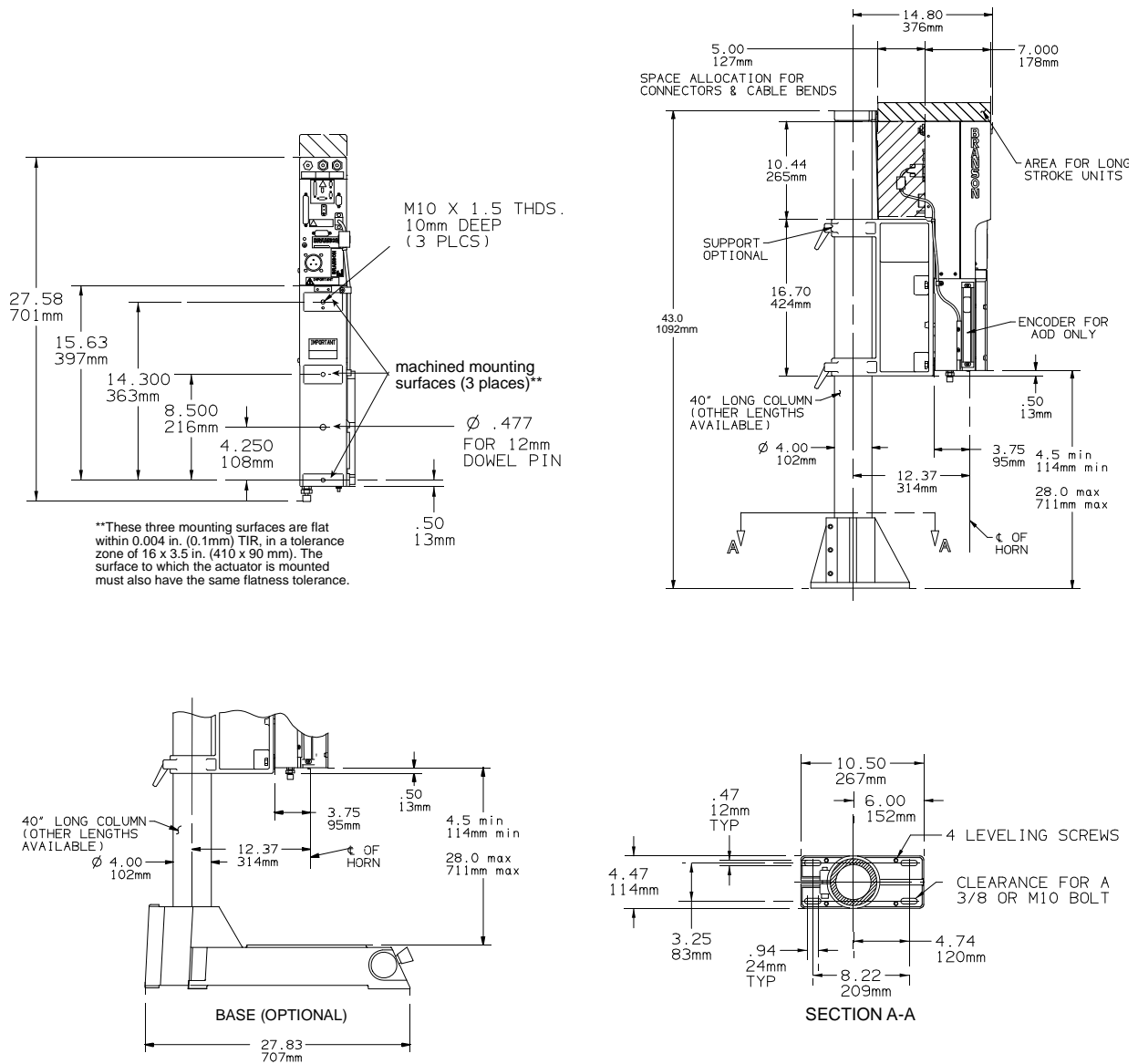
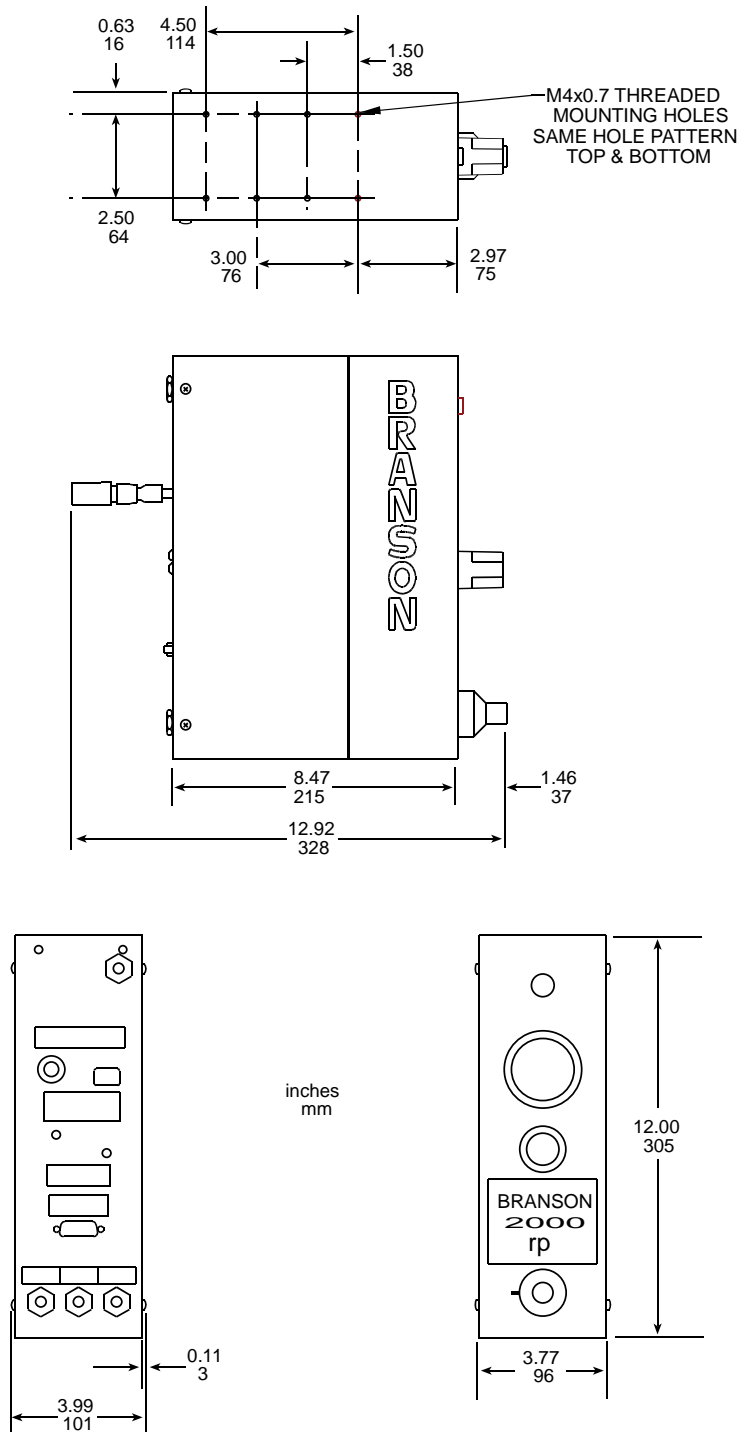

Figure 10 Remote Pneumatics Box Dimensional Drawing



Factory Air

The factory compressed air supply must be “clean (to a 5 micron level), dry and unlubricated” air with a regulated maximum pressure of 100 psig (690 kPa). The actuator* requires between 35-100 psi, depending on your application. The air supply should be capable of maintaining a 10 psi differential above the actuator operating air pressure. Stands include an in-line air filter. Actuators (alone, excepting aef) require a customer-provided air filter. The aef actuator is always supplied with a filter. A quick-disconnect fitting is suggested. Use a lockout device on the air line if required.

*As an exception, the aef actuator specifically requires either 70 or 90 psi minimum, depending on your application.



CAUTION

Synthetic air compressor lubricants containing Silicone or WD-40 will cause internal actuator damage and failure due to the solvents contained within these types of lubricants.

Air Filter

Actuators (alone) require a customer-provided air filter which protects from particulate matter of 5 microns or larger. If a stand is mounted in a position other than upright (vertical), its air filter* must be relocated and oriented so its bowl is the lowest point, and the air flow across the air filter is horizontal. This may require some re-plumbing of the existing equipment at the customer site. The air filter is held in place by two screws on a bracket bolted to the actuator support, and by the factory-installed tubing.



NOTE

*aef Actuator air filter is referred to as the Pneumatic Air Preparation (PAP) package, and consists of a precision regulator and two filters. The components of the PAP are normally located in the actuator housing. When actuator operation other than vertical is required, the PAP must be removed and positioned remotely, and oriented so that air flow across the 2 filter elements (5 micron particulate, and 0.3 micron coalescing) is horizontal.

Pneumatic Tubing and Connectors

Actuator assemblies are not externally plumbed from the factory, but provide conventional 1/4-inch OD pneumatic tubing connection at the air inlet. If making connections for an actuator, or if re-plumbing your system for a new air filter location, you must use 1/4-inch OD tubing* and connectors rated above 100 psi (use “Imperial Eastman® Poly-Flo Tubing 44-P-1/4” or equivalent, and appropriate connectors).



NOTE

*aef actuators use 5/16”, SMC and Poly-Flo tubing.

Pneumatic Connections to Actuator ae/aed/aef

Air connection to the actuator is made to the AIR INLET connector on the top rear of the actuator, with plastic pneumatic tubing. For installations using actuator-alone assemblies, you must provide an air filter assembly* which will support to at least 100 psig and remove particulate matter of 5 microns or larger.

i **NOTE**

*aef actuators require clean, dry input air at 100 psi filtered to 5 microns. The factory air will be further filtered to an operational level of 0.3 microns through the Pneumatic Air Package (PAP) located in the aef actuator housing or located remotely for operation of the actuator other than in a vertical position.

Pneumatic Connections to Actuator ao/aod/rp

For installations using actuator-alone assemblies, you must provide an air filter assembly which will support at least to 100 psig and remove particulate matter of 5 microns or larger. Primary air connection to the actuator is made to the air inlet found on the rp box. Three 1/4" OD tubing connections are required between the rp box and the actuator. Match label connections for the cylinder top, cylinder bottom, and cooling air line connections. If the rp box is not being used, all three air connections are still required installation Steps



WARNING

Moving parts can crush and pinch. Keep hands clear while operating.

CAUTION

If a stand is not mounted in a vertical position, the air filter (on the column support) must be removed, reoriented, and replumbed. Failure to do so can cause air filter failure.

Mounting the Stand (Actuator on Base)

The base must be bolted to your workbench to prevent tipping or undesired movement. Four mounting bolt holes are provided at the corners of the casting, and will accept your 3/8 inch or M10 cap screws. Use flat washers against the metal casting to prevent gouging.



CAUTION

Secure the base to your work surface using four bolts. Unit may tip over if actuator is rotated around the column.

1. Ensure there are no overhead obstructions and that no pinch or rub points exist. Remember that the actuator is taller than the column when fully raised, and there are exposed connections.

2. Mount the base to your workbench using four socket-head cap screws (customer provided, 3/8 inch (US bases) or M10 (metric bases)). Use flat washers against the metal casting to prevent gouging. The use of nylon lock nuts with your cap screws is suggested, to reduce loosening due to vibration and movement.
3. Connect factory air to the air hose on the stand (3/8 NPT male fitting on the hose). A quick-disconnect fitting is suggested. Use a lockout device on the air line if required.
4. Verify the base/start switch control cable is properly connected to the **back of actuator**.
5. Verify the linear encoder connector is properly connected to the **back of the actuator**.

Figure 11 Base mounting centers

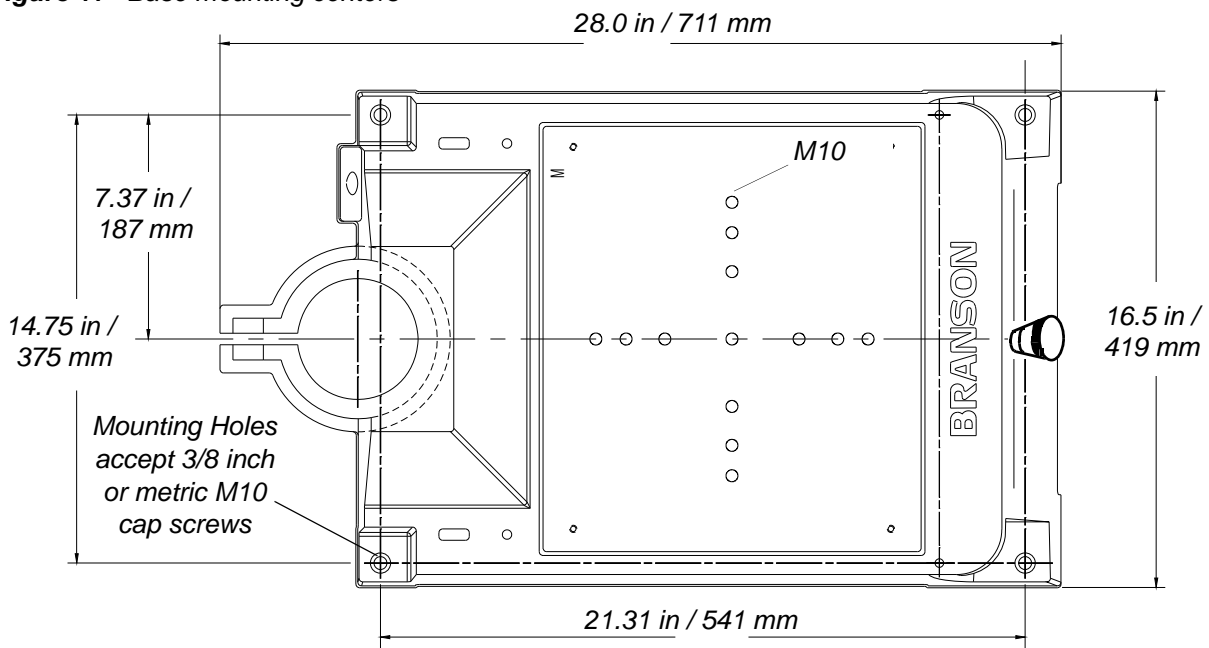

Leveling Fixture Setup

Preliminary Setup

The following plates utilize the Kit:

Plate Leveling, Inch	100-079-260
Plate Leveling, Metric	100-079-265
Plate 15 kHz Alignment/Leveling Combo	109-079-365



CAUTION

Before working on the welder, make sure to shut off the line power, disconnect the AC power plug, and disconnect the air supply.

Table 6 *Installing the Leveling Fixture*

Step	Action
1	Shut off the line power, disconnect the AC power plug, and disconnect the air supply.
2	Install the flat washer and spherical-head pivot pin into the center of the Base Fixture surface. Refer to Figure 11.
3	Install the four Leveling screws into the holes as shown in Figure 12.
4	Carefully place the Leveling Fixture, chamfered edges up and thread identifier towards the column, on the Base Fixture surface.
5	Install the four 1/4-20 locking screws, but do not tighten at this time. Refer to Figure 13.

Figure 12 *Spherical-head Pivot Pin*

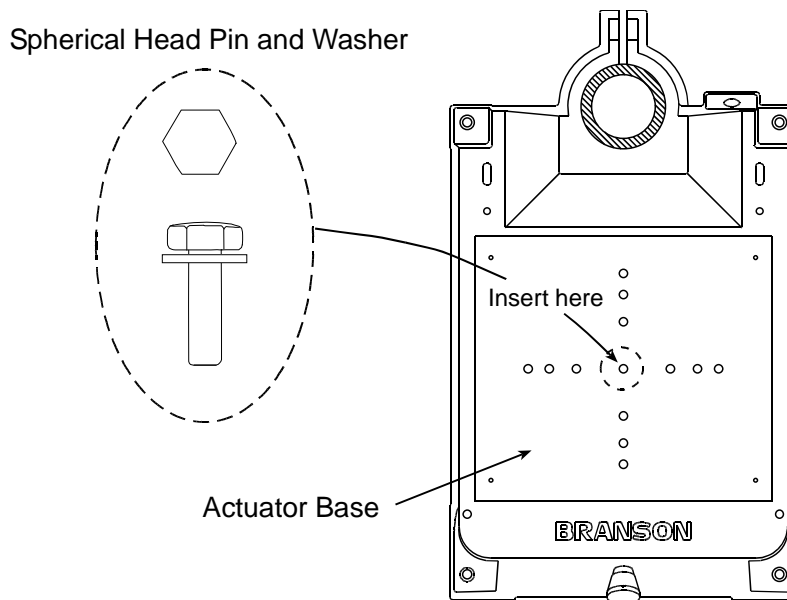

Figure 13 Installing a Leveling Screw

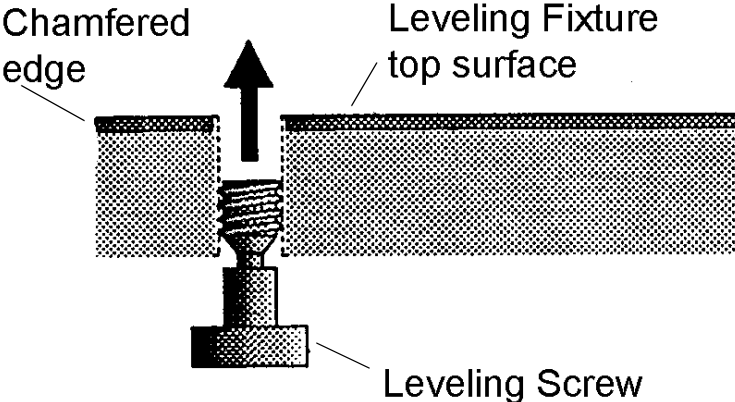
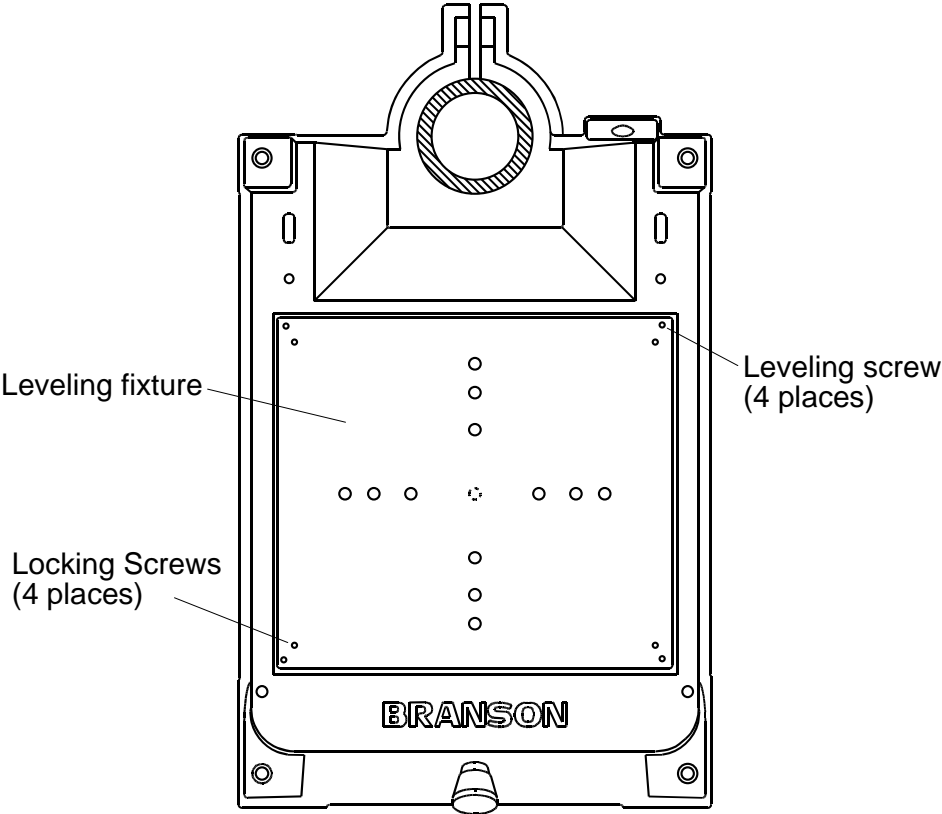

Figure 14 Securing the Leveling Fixture



CAUTION

Be careful not to over-tighten the Locking screws. This can distort the Leveling Fixture surface.

Setup

The following instructions are for setting up the welder with the Leveling Fixture.

Table 7 *Rough Alignment*

Step	Action
1	Install the converter-booster-horn stack.
2	Adjust the Leveling screws (in a pattern similar to the one shown in Figure 14) using the Branson T-handle wrench or equivalent. The screws should be close to, but NOT touching the Actuator Base at this time,
3	Install the part and fixture on the center of the Leveling Fixture.
4	Roughly align the horn, part, and fixture by manually lowering the horn over the center of the Leveling Fixture.

Figure 15 *Screw Installation Pattern*

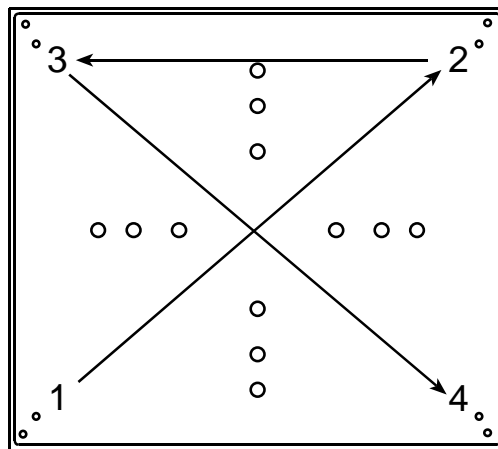

i **NOTE**

At this point, make sure the Leveling Screws do not contact the Base Fixture surface.

Table 8 *Secure Attachment and Precision Alignment of the Leveling fixture*

Step	Action
1	Connect the air supply and set the air gauge to a low working air pressure.
2	Use the Horn Down function to lower the horn on the part. (If your welder does not provide the Horn Down function, lower the horn manually.) Increase air pressure to the required working pressure.
3	Turn each leveling screw (in a pattern similar to the one shown in Figure 14) until the screw contacts the Base Fixture surface.

Table 8 *Secure Attachment and Precision Alignment of the Leveling fixture*

4	Tighten the locking screws to 50 in-lbs/5.65 newton-meters (in a pattern similar to the one shown in Figure 14). When finished, make sure the Leveling Fixture is level and secure on the Base Fixture surface.
5	Complete the Leveling Fixture installation by following the instructions in Section 3, "Horn, Part and fixture Alignment"

CAUTION

Make sure not to over-tighten the locking screws. Too much torque on the locking screws can distort the Leveling Fixture. Too little torque can cause the locking screws to loosen from vibration during a weld operation.

Horn, Part, and Fixture Alignment

Follow the instructions in Table 9 to do a precise alignment of the horn, part, and fixture before welding parts.

Table 9 *Precision Alignment*

Step	Action
1	Install the part and fixture on the Leveling Fixture, centered beneath the horn.
2	Place a piece of plain white paper between the horn and the part (Figure 15).

Figure 16 *Aligning Horn, Part, and Fixture*

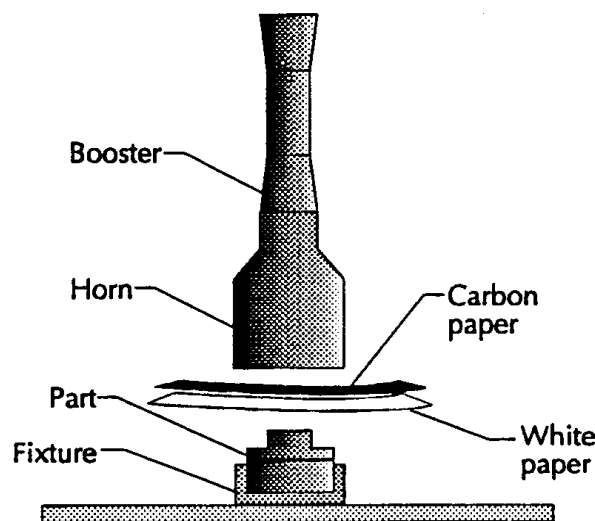

3	Place a piece of carbon paper face down on top of the white paper (Figure 15).
4	Set the welder for <i>minimum</i> weld time.
5	Weld the part.
6	Examine the resulting weld footprint on the piece of white paper (Figure 16).
7	Adjust the Leveling Screws until achieving a precise alignment of the horn, part, fixtures Leveling Fixture. Repeat Steps 2 - 7, if necessary.

Figure 17 Uneven Surface Example

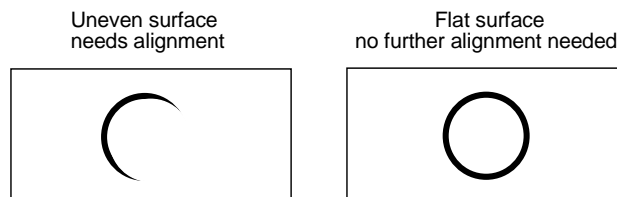

Mounting the Stand (Actuator on Hub-mounted column)

During unpacking, you removed the hub from the column/stand assembly. You must choose a mounting location for the hub that will support the column and actuator, and provide the hardware to mount it. Four mounting bolt holes are provided at the corners of the casting, and will accept your 3/8 inch or M10 hardware. Use flat washers against the metal casting to prevent gouging.

i **NOTE**

The hub must be installed with its front in the same direction as the front of the actuator. The column bolts of the hub are found on the rear of the hub. See Figure 11 for mounting details.

Figure 18 Mounting bolt pattern for the Hub (for Stand on Hub)

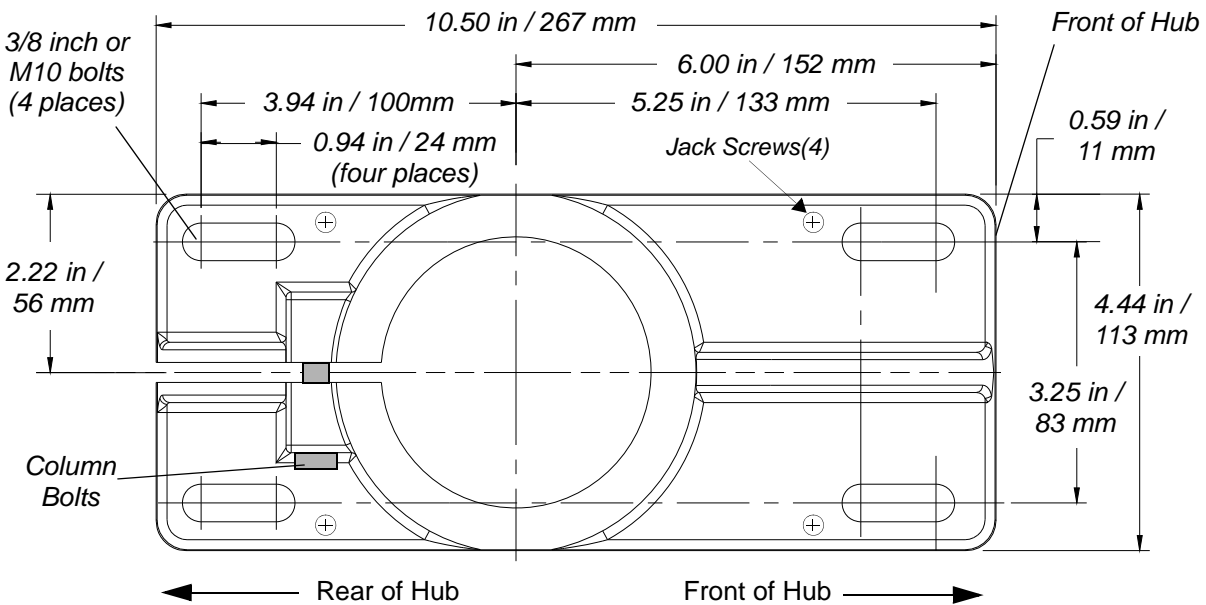

1. Locate the hub in the desired location. Ensure no overhead or side obstructions will interfere with normal operation or use of the system.

i NOTE

Mount the hub to your work surface using four bolts, 3/8-inch or M10 shank size, with flat washers against its metal casting (customer provided hardware).

2. Carefully lift the actuator and column assembly, and mount the column in the hub. Align the flat face of the spring swivel with the top-front of the actuator. Tighten the two bolts on the hub.
3. Connect factory air to the air hose on the stand (3/8 NPT male fitting on the hose). A quick-disconnect fitting is suggested. Use a lockout device on the air line if required.
4. Verify the base/start switch control cable is properly connected to the **back of actuator**.
5. Verify the linear encoder connector is properly connected to the **back of the actuator**.
6. Use jack screws to fine adjust the system level. A 3/16" allen wrench should be used for the 3/8"-16 x 3/4" jack screws.

Actuator (alone)

The actuator (alone) is intended for installation on your custom-made mounting support. It is located in place with a mounting pin and secured using three metric bolts.

1. Lift the actuator from the box. Carefully lay the assembly on its right side (NOT on the side with the linear encoder).

CAUTION

The actuator support bolts for the 2000-Series actuators are metric, M10 x 1.5 thread pitch, 25mm long. The support pin and mounting bolts must not extend more than 0.40 in (10 mm) into the actuator, otherwise, **binding or damage to the carriage may occur**. Use of a guide pin is suggested. It is not provided with the actuator. If you require a guide pin, use a solid metal dowel pin, 12mm diameter, which must not extend into the actuator more than 0.40 inch (10mm) from your support.

CAUTION

DO NOT use 900-Series M10 x 1.25 mounting bolts. They have a different thread pitch and will not interchange with those used on the 2000-Series.

Figure 19 Rear view of Actuator, showing Mounting Surface, Bolt and Guide Pin locations

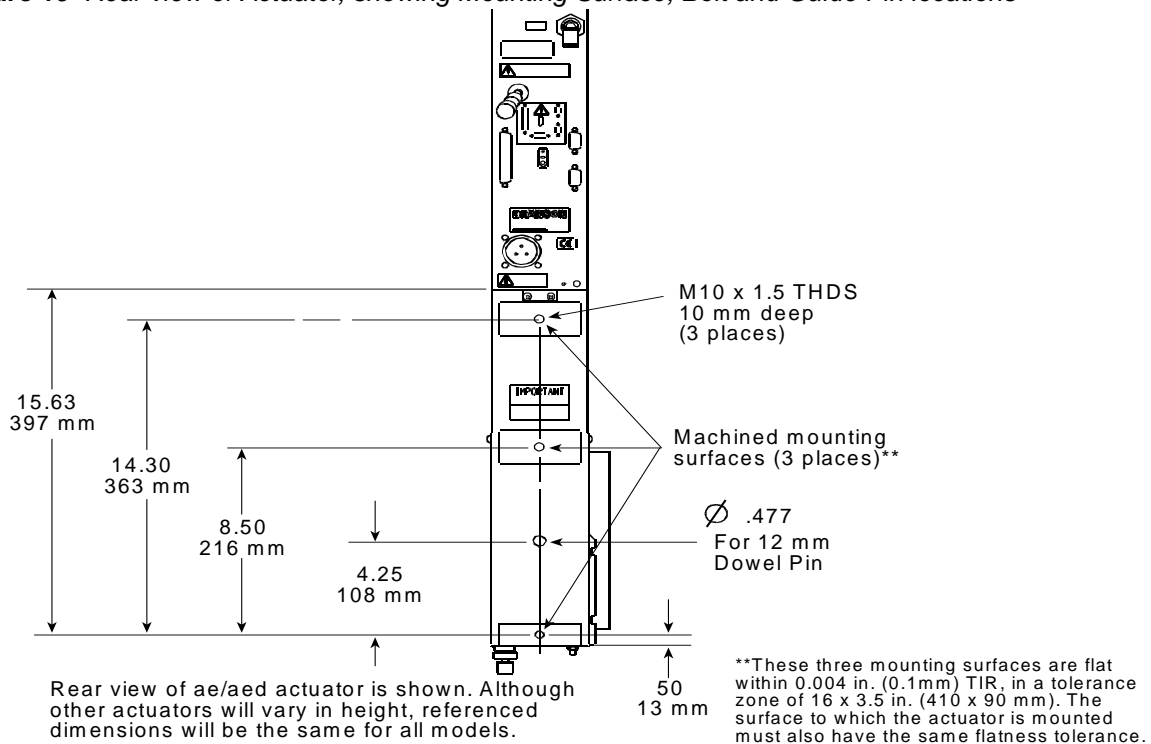

- Lift the actuator assembly into position on your mount, and secure using the metric bolts provided.

CAUTION

In the event you must use bolts of a different length, ensure that the bolts extend more than 0.25 inch (6 mm) into the threads in the actuator housing, but less than 0.40 inch (10 mm). This is necessary to prevent stripping the threads in the casting.

Mount the Power Supply

The power supply is designed to be placed on a workbench (rubber feet on bottom) within cable-length limits of the actuator, or it may be rack-mounted in a standard 19-inch Rack (using an optional rack mount handle kit). It has two rear-mounted fans which draw cooling air from rear to front, which must be free from obstruction. Do not place the power supply on the floor or in other locations that will allow dust, dirt or contaminants to be drawn into the power supply.

The controls on the front of the power supply must be accessible and readable for setup changes. All electrical connections are made to the rear of the power supply, which should be positioned in your workspace with adequate clearance (approximately 4 inches or more on either side, and 6 inches to the rear) for cable access and ventilation. Do not place anything on top of the power supply case.

In the event the system is to be installed in a high dust environment, the use of a fan filter kit (2000 t, ea, d, and f: 101-063-614, 2000b/bdc, 101-063-696) is required.

See Figure 5 for a dimensional drawing of the 2000 Power Supply.

Interconnect between Power Supply and Actuator

Figure 20 Connections on Rear of Power Supply

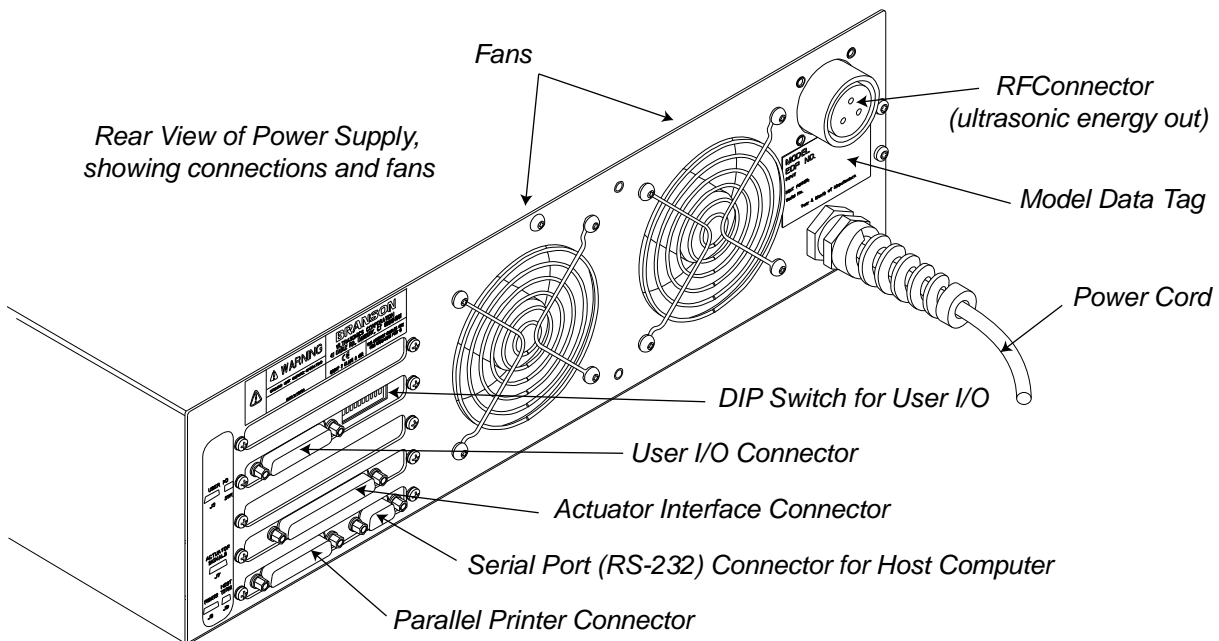

The cable lengths are limited based on the operating frequency of the welding system. Performance and results can suffer if the RF cable is crushed, pinched, damaged or modified. Contact your Branson Representative if you have special cable requirements. In some cases, remote operation from a User I/O or a Host Computer can be used to solve a distance limitation.

Input Power (Main)

The system requires single-phase input power, which you connect to the Power Supply using the integral power cord. See “Table 5, Input Power Requirements” for plug and receptacle requirements for your specific power level.

Refer to the unit’s Model Data Tag to be sure of the power rating of the Model in your system.

Output Power (RF Cable)

Ultrasonic Energy is delivered to a screw-on MS receptacle connection on the rear of the Power Supply, which is connected to the Actuator or the Converter (depending on your application).



WARNING

High voltage at connection and in cable. Never operate the System with the RF Cable disconnected or if the RF Cable is damaged.

If using a Branson 2000-series Actuator, there are two electrical connections between the Power Supply and the Actuator: the RF Cable and the Actuator Interface cable. A 37-pin cable is used for Power and Control Signalling between the 2000 Power Supply and a Branson Actuator. The cable connects to the rear of the Power Supply and the rear of the Actuator. Refer to Figure 14 for clarification of connections on rear of power supply.

For ground detect use, to have ultrasonic energy turn off when the horn comes in contact with your electrically isolated fixture or anvil, it is necessary to install Branson cable EDP No. 100-246-630 from the MPS/GDS receptacle on the rear of the actuator to your isolated fixture/anvil in order to utilize this feature.

There can be other connections to the Actuator, and other connections to the Power Supply, but these are the only two standard connections, depicted below.

Figure 21 Electrical Connections from Power Supply to a 2000-series Actuator

*ae/aed actuator air input shown
**aed and aef only

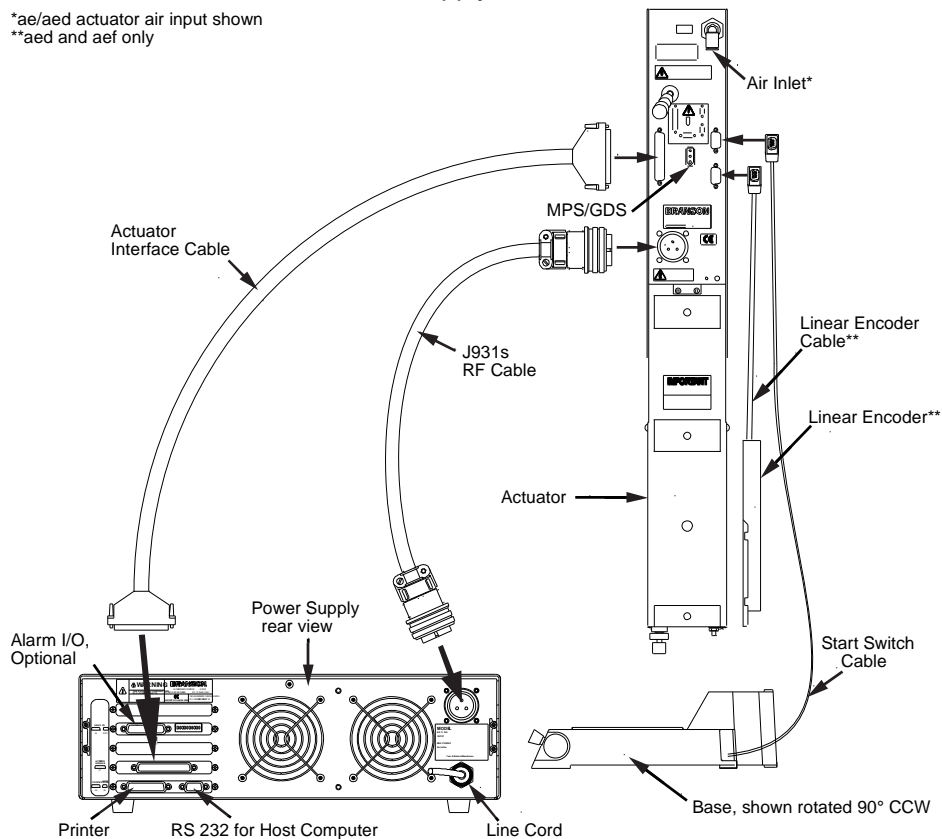

* aed and aef only

** ae/aed actuator air input shown. Refer to Figure 7 for aef air input.

Start Switch Connection (Automation)

A Branson actuator requires 2 start switches and emergency stop connection. Stands on a base include this connection (factory installed and connected from the base) while the stand on a hub and actuator (alone) applications require the user make their own start switch/E-stop connections, as follows:

Figure 22 Start Switch Connection Codes

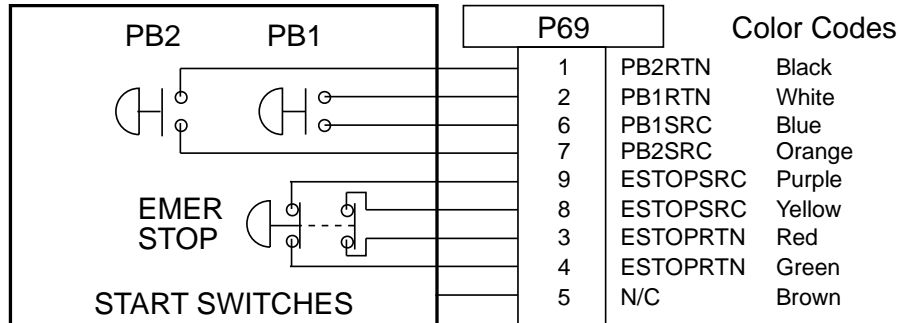

i **NOTE**

Solid state devices may be used in lieu of mechanical start switches providing their leakage current does not exceed 0.1 mA.

i **NOTE**

Start Switches PB1 and PB2 must be closed within 200 milliseconds of each other, and remain closed until the WELD ON signal is active, to effect a start condition.

BASE/START is the DB-9 female connection on the back of the actuator. Your cable requires a male DB-9 (D-shell) connector.

PB1 and PB2 are two normally open start-switches which must be operated simultaneously to start the welding cycle. These must be closed within 200 milliseconds of each other, or error message: "Start Sw Time " will display. This doesn't require a reset, but for the next cycle, switches must be within time limit to preclude re-occurrence of error message. Refer to Note above.

EMER STOP is an emergency stop switch, normally closed.

Serial (RS-232) Port Connector

An RS-232c serial port (DB-9 format) is provided for the Host Computer option. Only three data leads of this port are supported at this time (Data Send, Data Receive, and Signal Ground). The remainder of the leads 'reserved'. A null modem cable is required.

The comport parameters are fixed, can not be altered or viewed in the menu.

The fixed values are:

1. com speed = 9600 baud
2. no parity
3. 1 stop bit
4. 8 data bits

Parallel Printer Connector

The Printer Connector supports several printer models, both dot matrix and ink jet, to provide printed reports of your weld information, and to provide graphical representation of your weld results. The tractor feed feature of dot matrix printers is preferred for many manufacturing applications. If necessary, consult your Branson representative for recommendations for your specific needs.

The printers listed in Table 6 have been fully tested to confirm compatibility with Branson products. Printers that were tested and are NOT compatible are the Panasonic 1091 and Epson LX300.

The printer interface uses a standard 36-pin Centronics cable (Branson printer cable EDP 100-143-043).

Table 10 Printer Compatibility

Manufacturer	Model No		
Epson	LQ-570	FX-980	Stylus 900
Okidata	5340HE	320 Turbo	520**
Panasonic	1180	1150	
H-P	610C	540	600

** Includes both off the shelf and Branson supplied units. However, all units excepting the Branson supplied Okidata 520 may not stop printing when abort is selected in the menu. The data may have been transferred to the printer and can't be halted.

i **NOTE**

Power for the Power Supply and the printer must be OFF before installing the printer cable. If it is installed with power on, the power supply front panel may lock up.

User I/O Interface

The user I/O is a standard interface for automation, provided on the power supply. It provides the ability for the customer to make their own interface for their automation or special control or reporting needs. The interface cable has an HD44 female D-shell connection on the rear of the power supply. The electrical interface outputs may be configured for open collector mode or for signal mode (signal voltage levels as indicated), by setting the user I/O DIP switch.

DIP switch SW1 for the user I/O is located next to the J3 on the back of the 2000-series power supply. User I/O interface cable pinout is listed in [Table 11](#).

Figure 23 User I/O Cable Identification and Wire Color Diagram

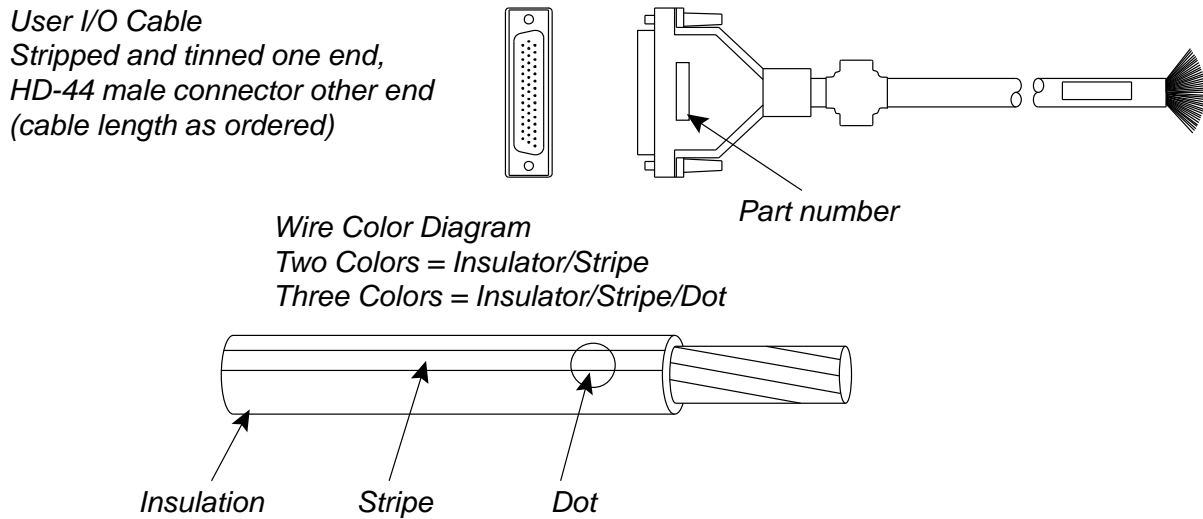

Table 11 User I/O Cable Pin Assignments

Pin	Signal Name	Signal Type	Direction	Signal Range	Definition	Colors
7	ACT_CLEAR	0V True	Output	0/24V, 100mA	Actuator clear signal	Red/Wht
24	AMPLITUDE_OUT	Analog	Output	0V to 10V	Amplitude signal from PS	Red/Blk/Grn
2	CYCLE_ABORT	24V True	Input	0/24V, 100mA		Red/Blk
3	EXT_RESET	24V True	Input	0/24V, 100mA	System Reset	Grn/Blk
18	EXT_SEEK+	24V True	Input	0/24V, 100mA		Red/Blk/Wht
38	FREQ_OUT	Analog	Output	-10V to +10V	Frequency Signal from PS	Blk/Wht/Blu
6	G_ALARM	0V True	Output	0/24V, 100mA		Blk/Wht
14	GEN_ALARM_RELAY_1	Relay Contact	Output	40V, 0.25A	Contact Closure	Red/Grn
29	GEN_ALARM_RELAY_2	Relay Contact	Output	40V, 0.25A	Contact Closure	Wht/Red/Orn
1	J3_1_INPUT	24V True	Input	0/24V, 100mA	User definable inputs. Refer to Table 4.7 to view available selections.	Wht/Blk
17	J3_17_INPUT	24V True	Input	0/24V, 100mA		Wht/Blk/Red
19	J3_19_INPUT	24V True	Input	0/24V, 100mA		Grn/Blk/Wht
31	J3_31_INPUT	24V True	Input	0/24V, 100mA		Wht/Red/Blu
32	J3_32_INPUT	24V True	Input	0/24V, 100mA		Blk/Wht/Grn
33	J3_33_INPUT	24V True	Input	0/24V, 100mA		Wht/Blk/Grn

8	J3_8_OUTPUT	24V True	Output	0/24V, 100mA	User definable outputs. Refer to Table 4.7 to view available selections.	Grn/Wht
22	J3_22_OUTPUT	24V True	Output	0/24V, 100mA		Blk/Red/Grn
36	J3_36_OUTPUT	24V True	Output	0/24V, 100mA		Orn/Red Grn
9	MEM	Analog	Output	-10V to +10V	Memory Signal from PS	Blu/Wht
11	MEM_CLEAR	Open Collector	Output	24V, 25mA max	Memory Clear signal send to PS	Wht/Red
40	MEMORY_STORE	Open Collector	Output	24V, 25mA max	Memory store from PS	Red/Wht/Blu
34	PB_RELEASE	0V True	Output	0/24V, 100mA		Red/Wht/Grn
37	PWR	Analog	Output	0V to 10V	Power Signal from PS	Blu/Red/Grn
21	READY	0V True	Output	0/24V, 100mA		Blu/Blk/Wht
5	REJECT	0V True	Output	0/24V, 100mA		Blu/Blk
43	READY_RELAY_1	Relay Contact	Output	40V, 0.25A	Contact Closure	Blu/Orn/Red
15	READY_RELAY_2	Relay Contact	Output	40V, 0.25A	Contact Closure	Orn/Grn
26	RUN	Open Collector	Output	24V, 25mA max	Run signal send to PS	Orn/Blk/Grn
39	SEEK	Open Collector	Output	24V, 25mA max	Seek Signal send to PS	Wht/Blk/Blu
4	SOL_VALVE_SRC	24V	Output	0/24V, 125mA	SV1 Source	Orn/Blk
16	SOL_VALVE_RTN	24V Return	Input	0V	SV1 Return	Blk/Wht/Red
20	SUSPECT_PART	0V True	Output	0/24V, 100mA		Orn/Blk/Wht
10	USER_AMP_IN	Analog	Input	-10V to +10V	User Amplitude control signal	Blk/Red
25	USER_FREQ_OFFSET	Analog	Input	-10V to +10V	User Freq. offset control signal	Grn/Blk/Orn
35	WELD_ON	0V True	Output	0/24V, 100mA	Start of sonics and trigger	Grn/Wht/Blu
30	WELD_ON_RELAY_1	Relay Contact	Output	40V, 0.25A	Contact Closure	Orn/Wht/Blu
44	WELD_ON_RELAY_2	Relay Contact	Output	40V, 0.25A	Contact Closure	Blk/Orn/Red

CAUTION

Ensure all unused wires are properly isolated. failure to do so may result in Power Supply or system failure.

Pin	Signal Name	Signal Type	Direction	Signal Range	Definition	Colors
23	+10V_REF	Analog	Output	10.0V	10VDC ref. voltage from PS	Wht/Red/Grn
12	24V_RTN	24V Ground	Input	0V	24V Return	Orn/Red
13	24V_SRC	24V Source	Output	24V, 1.25A max	24V Source	Blu/Red
27	24V_RTN	24V Ground	Input	0V	24V Return	Blu/Wht/Orn
28	24V_SRC	24V Source	Output	24V, 1.25A max	24V Source	Blk/Wht/Orn
41	24V_RTN	24V Ground	Input	0V	24V Return	Grn/Orn/Red
42	24V_SRC	24V Source	Output	24V, 1.25A max	24V Source	Orn/Red/Blu

You can find additional information about User I/O Input and Output Function Selection in your power supply or actuator manual, version 9.x software only.

Input Power Plug

If you must add or change the input power plug, use the following color code for the conductors found in the international harmonized line cord. Add the plug that is appropriate for your input power receptacle.

CAUTION

The power supply can be permanently damaged if it is connected to the incorrect line voltage, or if the wiring connection is mis-wired. It also presents a safety hazard if mis-wired. Use of the correct plug or connector helps prevent incorrect connections.

Figure 0.1 International Harmonized Line Cord Color Code

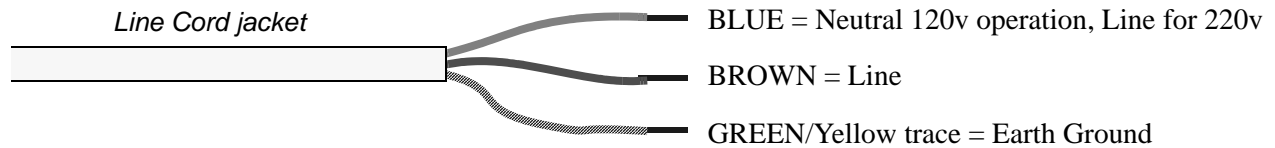

User I/O DIP Switch (SW1)

DIP switch SW1, for the user I/O is located next to the J3 on the back of the 2000-series power supply, as shown in [Figure 20 on page -27](#). The settings of these switches affect the user I/O signals. Factory default setting is for all dip switches is set to ON (closed: switch position closest to number designation).

- If the dip switch is set to the ON (closed) position, the corresponding Output pin will be configured as the current source, 25mA max.
- If the dip switch is set to the OFF (open) position, the corresponding Output pin will be configured as an "open collector", 24VDC, 25 mA max. current sink.

Table 12 User I/O DIP Switch Functions

Switch Position	Signal Description	Output Signal
1	$\overline{\text{REJECT_SIG}}$	$\overline{\text{REJECT}}$
2	$\overline{\text{SUSPECT_SIG}}$	$\overline{\text{SUSPECT}}$
3	$\overline{\text{PB_RELEASE_SIG}}$	$\overline{\text{PB_RELEASE}}$
4	$\overline{\text{G_ALARM_SIG}}$	$\overline{\text{G_ALARM}}$
5	$\overline{\text{READY_SIG}}$	$\overline{\text{READY}}$
6	$\overline{\text{WELD_ON_SIG}}$	$\overline{\text{WELD_ON}}$
7	$\overline{\text{ACTUATOR_CLEAR_SIG}}$	$\overline{\text{ACT_CLEAR}}$
8	$\overline{\text{J3_22_OUT_SIG}}$	$\overline{\text{J3_22_OUTPUT}}$
9	$\overline{\text{J3_36_OUT_SIG}}$	$\overline{\text{J3_36_OUTPUT}}$
10	$\overline{\text{J3_8_OUT_SIG}}$	$\overline{\text{J3_8_OUTPUT}}$

i **NOTE**

Do not permanently remove the Cover from the Power Supply because it is required for proper system cooling.

Guards and Safety Equipment

Emergency Stop Control

If you use the Emergency Stop button on the Actuator to terminate a weld, twist the button to reset it. (The welder will not operate until this button is reset.) You must then press Reset at the power supply. If you are running automation, you can use external reset that is connected to your User I/O board.

Figure 24 Actuator Emergency Stop Button

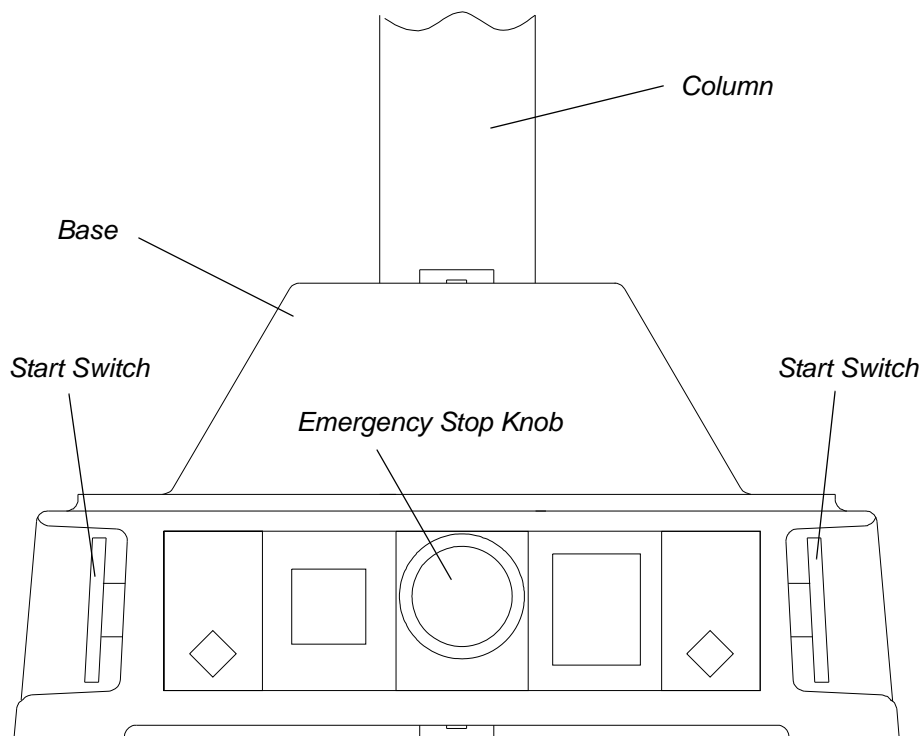

If you are using an Emergency Stop signal from the Start Switch cable, you must clear the Emergency Stop condition before the System will operate.

i **NOTE**

Emergency Stop is to be used for human or machine emergencies only.

The 2000 Series control system has been designed to conform to the safety requirements of NFPA 79, EN 60204-1 and CFR 1910.212.

Two Hand Control of the 2000 Series control system has been designed to comply with Type 3 of NFPA, and Type III of EN 60204-1 which require:

- Concurrent actuation by both hands of two control devices (start switches) within a specified time limit of each other (200 milliseconds);

- Where this time limit is exceeded, both control devices must be released before operation can be initiated;
- Continuous concurrent actuation during the hazardous condition;
- .Machine operation ceases upon the release of either one or both of the control devices (start switches) when the hazardous condition is still present - both control devices must be released before operation can be initiated again.

The Emergency Stop functions as a category 0 stop of both NFPA 79 and EN 60204-1.

It meets the following requirements:

- It overrides all other functions and operations in all modes;
- Power to the machine actuators (solenoid valve and air cylinder) that can cause a hazardous condition are removed as quickly as possible without creating other hazards;
- Reset does not initiate a restart.
- The emergency stop function uses only hard-wired electromechanical components. Its operation does not depend on electronic logic or on the transmission of commands over a communications network or link.

Rack Mount Installation

If the system is Rack Mounted, you need to order the Rack Mount handle kit. The kit includes two rack mounting handles and two corner pieces, which support the handles and provide the rack mount interface.



CAUTION

The Rack Mount handle kit does NOT support the power supply in the rack. The weight of the power supply must be supported by integral brackets of the rack itself.



NOTE

Do not permanently remove the Cover from the Power Supply because it is required for proper system cooling.

Step	Procedure
1	Order and obtain the Rack Mount kit for your Power Supply. The brackets in the Kit are designed for standard 19-inch rack mounting options.
2	From the front corners of the Power Supply, remove the Front Corner bezels by removing the two Phillips screws. Save the screws.
3	Noting that one side of each bracket is countersunk to accept the provided flathead screws, assemble the Rack Mount Handles as shown in Figure 25 'Detail of Rack Mount Handle Kit Assembly' on page -39. (This shows only the Right bracket and handle; the left side is a mirror-image.) Tighten the screws securely and so they are flush.
4	Re-using the screws you removed in Step 2, install the assembled Handle in place of the Front Corner pieces.
5	Save the removed hardware corner pieces.
6	When you are ready to install the unit, use the hardware from your Rack Mounting system to locate the Power Supply.

Figure 25 Detail of Rack Mount Handle Kit Assembly

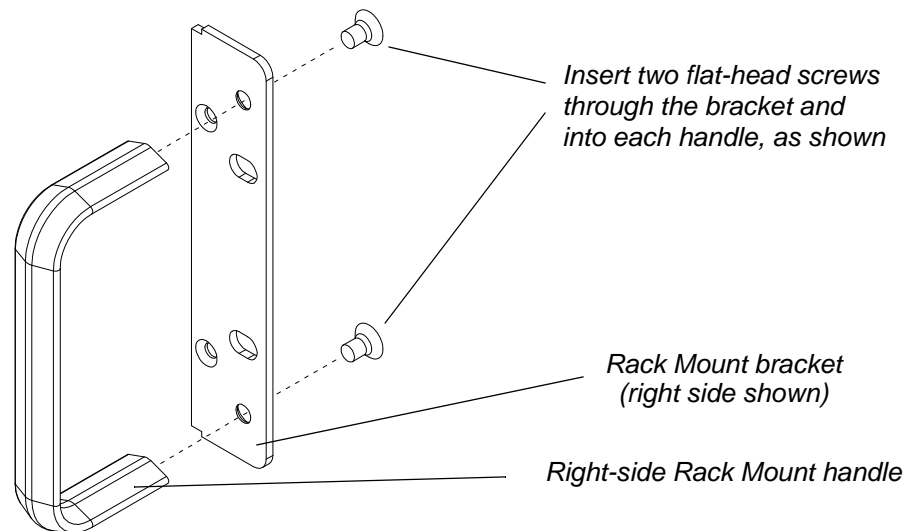

CAUTION

The Rack Mount handle kit does NOT support the power supply in the rack. The weight of the power supply must be supported by integral brackets of the rack itself.

Assemble the Acoustic Stack

This section describes and indicates the steps for assembling the acoustic stack. The steps are organized around the 20 kHz, 30 kHz and 40 kHz stack types as listed in the sub paragraphs below. An illustration for assembling typical 20 kHz stack is shown in [Figure 26](#).

CAUTION

If necessary, secure the largest portion of a square or rectangular horn in a soft jawed (brass or aluminum) vise. NEVER attempt to assemble or remove a horn by holding the converter housing or the booster clamp ring in a vise.

CAUTION

Do not use silicone grease with Mylar washers. Use only 1 (one) Mylar washer of the correct inside and outside diameters at each interface.

Table 13 Tools

Tool	EDP Number
20 kHz Torque Wrench	101-063-617
40 kHz Torque Wrench	101-063-618
15 kHz spanner Wrench	201-118-034
20 kHz Spanner Wrench	201-118-019
30 kHz Spanner Wrench	201-118-033
40 kHz Spanner Wrench	201-118-024
Silicone Grease	101-053-002

For a 15 kHz System

Step	Action
1	Clean the mating surfaces of the converter, booster, and horn. Remove any foreign material from the threaded holes.
2	Install the threaded stud into the top of the booster. Torque to 450 in-lbs, 50.84Nm. If the stud is dry, apply 1 or 2 drops of a light lubricating oil before installing.
3	Install the threaded stud into the top of the horn. Torque to 450 in-lbs, 50.84Nm. If the stud is dry, apply 1 or 2 drops of a light lubricating oil before installing.
4	Install a single Mylar washer (matching the size of the washer to the stud) to each interface.
5	Assemble the converter to the booster and the booster to the horn.
6	Torque to 250 in-lbs, 28.25 Nm.

For a 20kHz System

Step	Action
1	Clean the mating surfaces of the converter, booster, and horn. Remove any foreign material from the threaded holes.
2	Install the threaded stud into the top of the booster. Torque to 450 in-lbs, 50.84 Nm. If the stud is dry, apply 1 or 2 drops of a light lubricating oil before installing.
3	Install the threaded stud into the top of the horn. Torque to 450 in-lbs, 50.84 Nm. If the stud is dry, apply 1 or 2 drops of a light lubricating oil before installing.
4	Install a single Mylar washer (matching the size of the washer to the stud) to each interface.
5	Assemble the converter to the booster and the booster to the horn.
6	Torque to 220 in-lbs, 24.85 Nm.

For a 30kHz System

Step	Action
1	Clean the mating surfaces of the converter, booster, and horn. Remove any foreign material from the threaded holes.
2	Install the threaded stud into the top of the booster; torque to 290 in-lbs, 32.76 Nm.
3	Install the threaded stud into the top of the horn; torque to 290 in-lbs, 32.76 Nm.
4	Install the retainer ring on the booster using the 4 M3 x 8 screws and lock washers provided in the CA-30 Converter Kit. Line up all screw holes before inserting screws. Apply Loctite® ¹ 222 threadlocker and tighten

	<p>CAUTION</p> <p><i>If ring is not oriented properly, it is possible to damage the converter or cause actuator failure. (booster must be installed to converter with ring facing converter, refer to Figure 27.)</i></p>
5	Install a single Mylar washer (matching the size of the washer to the stud) to each interface.
6	Screw the converter onto the booster.
7	Torque to 185 in-lbs, 21 Nm.
9	Screw the booster onto the horn.
10	Repeat Step 7.

1. Loctite is a registered trademark of Henkel Corporation, U.S.A.

For a 40kHz System

Step	Action
1	Clean the mating surfaces of the converter, booster, and horn. Remove any foreign material from the threaded holes.
2	Apply a drop of Loctite® 290 threadlocker (or equivalent) to the studs for the booster and horn.
3	Install the threaded stud into the top of the booster; torque to 70 in-lbs, 7.9 Nm, and let cure for 30 minutes.
4	Install the threaded stud into the top of the horn; torque to 70 in-lbs, 7.9 Nm, and let cure for 30 minutes.
5	Coat each interface surface with a thin film of silicone grease – <i>but do not apply silicon grease to a threaded stud or tip.</i>
6	Screw the converter to the booster.
7	Torque to 95 in-lbs, 8Nm.
8	Slide the booster/converter assembly into the adapter sleeve. Screw on the adapter sleeve ring nut and leave loose.
9	Screw the booster onto the horn.
10	Repeat Step 7.
11	Securely tighten the adapter sleeve ring nut with the spanner wrenches shipped with the sleeve assembly.

Figure 26 Assembling the 20kHz Acoustic Stack

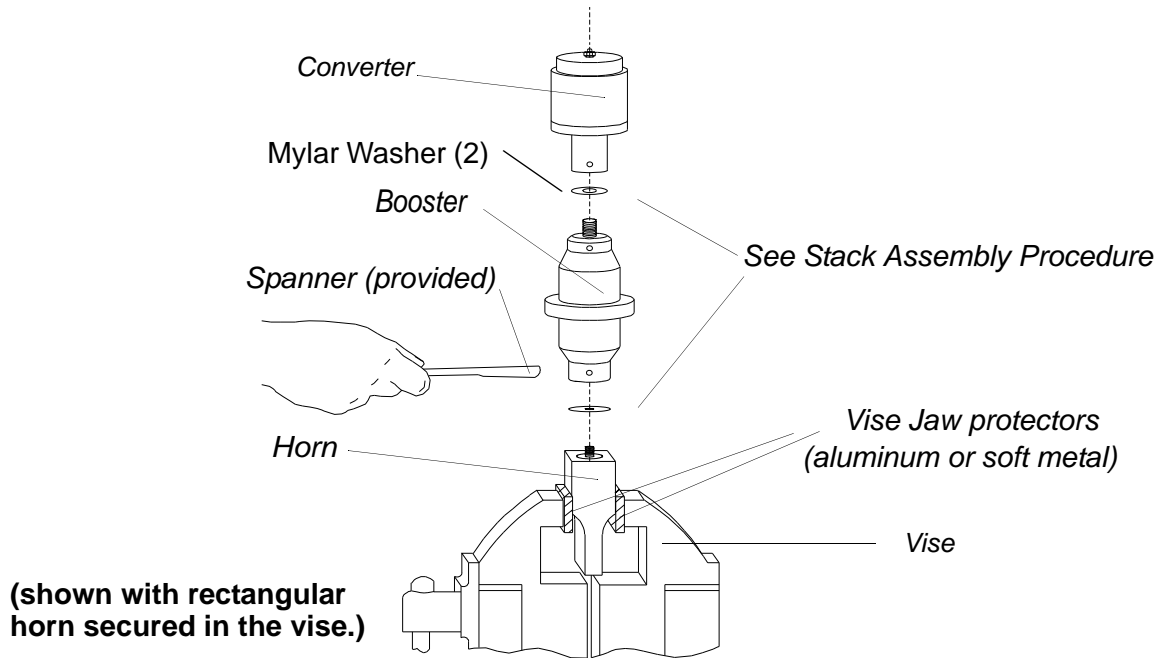

Stack Assembly Torque Tables

i NOTE

The use of a Branson torque wrench or the equivalent is recommended. P/N 101-063-617 for 20kHz systems, and 101-063-618 for 40kHz systems.

Table 14 Stud Torque Values

Used On	Stud Size	Torque	EDP #
15 kHz	1/2" x 20 x 1-1/2"	450 in.-lbs, 50.84 Nm.	100-098-123
20 kHz	1/2" x 20 x 1-1/4"	450 in.-lbs, 50.84 Nm.	100-098-370
20 kHz	1/2" x 20 x 1-1/2"	450 in.-lbs, 50.84 Nm.	100-098-123
30 kHz	3/8" x 24 x 1"	290 in.-lbs, 32.76 Nm.	100-298-170
40 kHz *	M8 x 1.25	70 in.-lbs, 7.90 Nm.	100-098-790

* Add a drop of Loctite 290 threadlocker to the stud. Torque and let cure for 30 minutes before use.

Connecting Tip to Horn

1. Clean the mating surfaces of the horn and tip. Remove foreign matter from the threaded stud and hole.
2. Hand assemble the tip to the horn. Assemble dry. Do not use any silicone grease.
3. Use the spanner wrench and an open-end wrench (Refer to Figure 23) and tighten to the following Torque tip specifications:

Figure 27 *Connecting Tip to Horn*

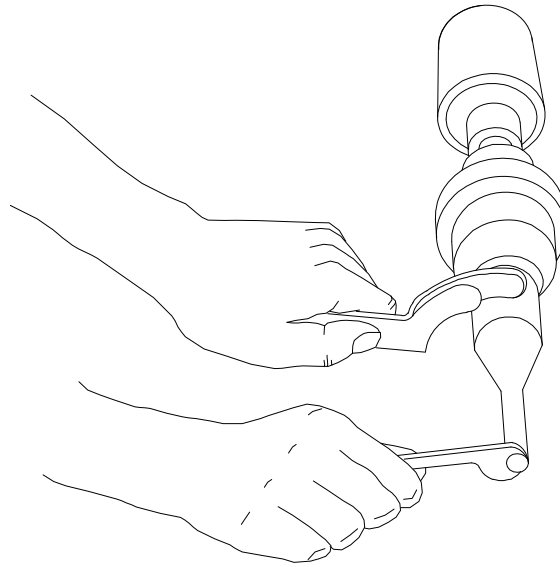

Table 15 *Tip to Horn Torque Values*

Tip Thread	Torque
1/4 - 28	110 in.-lbs, 12.42 Nm.
3/8-24	180 in.-lbs, 20.33 Nm.

Installing the Ultrasonic Stack in the Actuator

15 kHz, 20 and 30 kHz Stacks

The ultrasonic stack must first be assembled. To install the stack:

1. Make sure that the system power is turned off by disconnecting the power plug.
2. Loosen the four door screws.
3. Pull the door straight off and set it aside.
4. Take the assembled ultrasonic stack and align the ring on the booster just above the support washer in the carriage. Firmly push the stack into place, with the acorn nut on the top of the converter making contact with the contactor in the top of the carriage.
5. Reinstall the door assembly, and start the four door screws.

6. Align the horn by rotating it, if necessary. Torque the carriage door to 20 in.-lbs to secure the stack.

Figure 28 Installing the CA-30 Stack in a Branson Actuator

Verify that the ring/screw head orientation is as shown below, before installing stack in the actuator. (Ring not required for some 30K boosters.)

i NOTE
If ring is not oriented properly, it is possible to damage the converter or cause actuator failure. (booster must be installed to converter with ring facing converter)

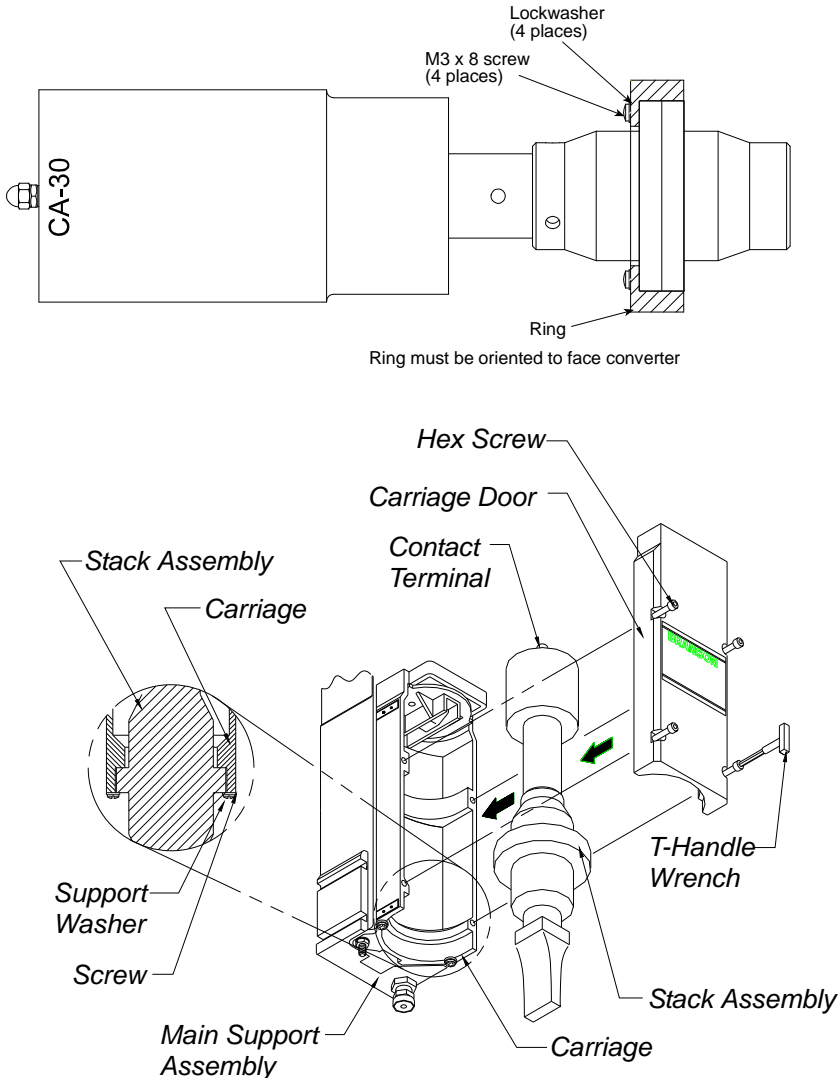

40 kHz Stacks

1. Make sure that the system power is turned off by disconnecting the power plug.
2. Place the converter / booster in the sleeve.

Figure 29 *Installing the 40kHz Stack in a Branson Actuator*

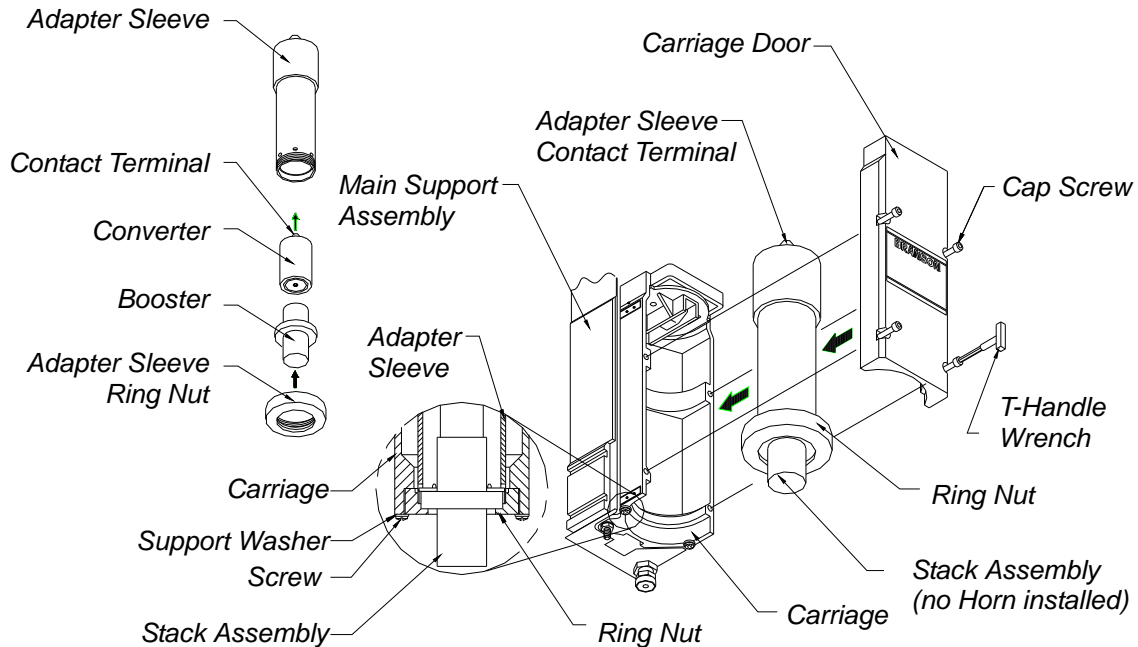

3. Loosen four carriage door screws.
4. Pull the door straight off and set it aside.

CAUTION

Do not attempt to hold the sleeve in a vise. It can be easily crushed or damaged.

5. Take the assembled sleeve and align the ring nut on the booster just above the support washer in the carriage. Firmly push the sleeve into place, with the acorn nut on the top of the sleeve making contact with the contactor in the top of the carriage.
6. Reinstall the door assembly, and start the four door screws.
7. Align the horn by rotating it, if necessary. Torque the carriage door to 20 in.-lbs to secure the stack.

Mounting the Fixture on the Branson Base

(hardware and mounting holes)

The base provides mounting holes for your fixture. Mounting holes are also provided for the optional Branson leveling plate kit. The base is tapped for metric M10 hardware (indicated by an “M” on the base). The mounting holes are arranged in three concentric bolt circles with the following dimensions.

CAUTION

The base is cast metal and the mounting holes can become stripped if the hardware is over-tightened. Tighten your hardware only enough to prevent movement of your fixture.

Figure 30 Mounting Circles on Base

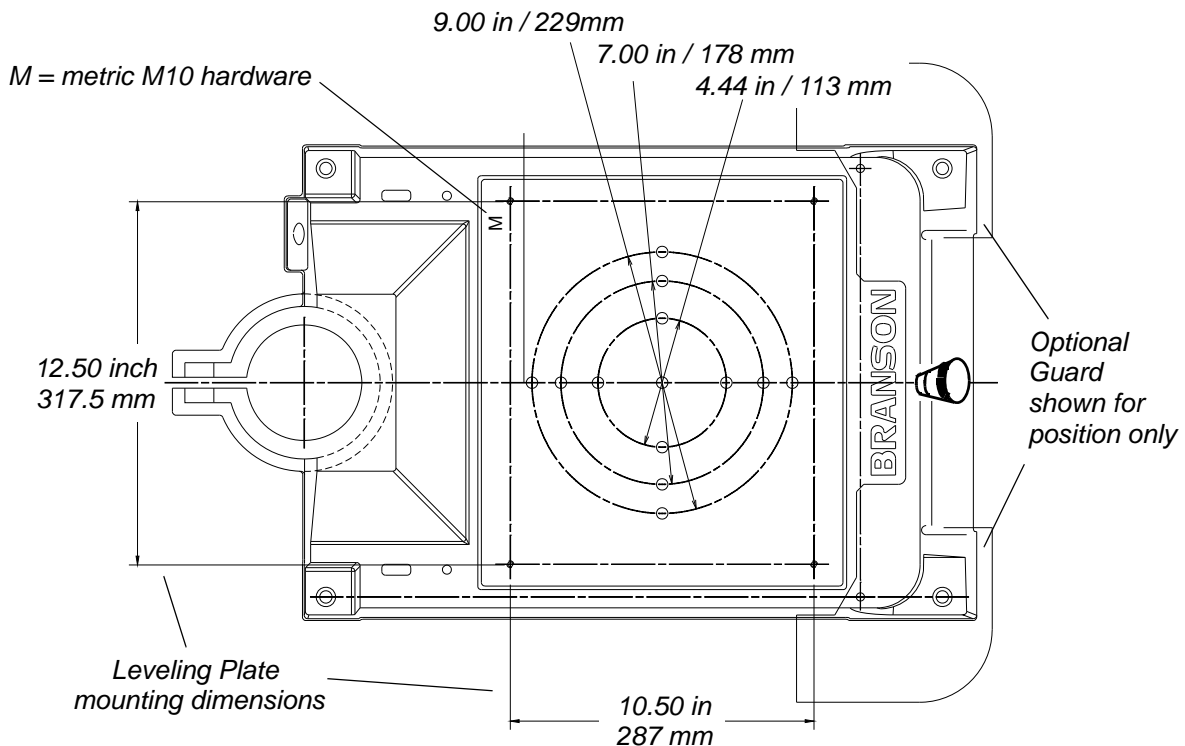

The optional guard, EDP 101-063-550, (sometimes required with very large horns) is shown for position only. It extends several inches to either side of the base, and prevents the user from operating the welder and pinching their fingers or hands between the base and the tooling.

Converter Duty Cycle and Cooling

Converter performance and reliability can be adversely affected if the converter is subjected to temperatures in excess of 140° F (60° C). The converter front driver temperature should not exceed 122° F (50° C). To prolong converter life and maintain a higher degree of system reliability, it is advisable to cool the converter assemblies with a directed stream of clean, dry, compressed air, particularly if your application calls for continuous ultrasonics operation. Converter cooling is especially critical in 40kHz applications.



NOTE

Additional heat will be generated if the converter-booster-horn interfaces need reconditioning. Be sure the stack is in good condition and properly assembled.

Two types of converters are normally used with Branson equipment:

- R-type equipped with a barbed cooling nipple that accommodates 1/16 in. I.D. flexible tubing to direct cooling air to the interior of the converter assembly.
- J-type equipped with holes in the perimeter of the top and bottom plates to provide chimney convection cooling. If additional cooling is required for this type of converter, a directed orifice must be placed under the converter.

Two procedures can be used to determine if a converter is operating at a temperature that is too high. In both cases, determinations should be made immediately after substantial machine operation and without power applied to the horn.

- Using a pyrometer (or similar temperature measuring device), tape the probe on to the outer shell of the converter assembly. Wait for the probe to reach the temperature of the shell. If the temperature is 120° F (48° C) or higher, a cooling air stream is required.
- If a temperature measuring device is unavailable, use your hand to feel the shell of the converter. If the converter is hot to the touch, a cooling air stream is required.

If converter cooling is required, use the following procedure:

1. Start with a 50 psi air source (or higher) from a 0.060 in. orifice (I.D.). On a J-type converter, direct the air upward from the bottom of the assembly.
2. Perform a run of welding operations.
3. Immediately after completing the run, check the converter temperature.
4. If the converter is still too hot, increase the diameter of the orifice in small increments until the temperature falls within the safe operating ranges described in Table 17.

A 0.060 in. orifice at 50 psi will result in a reading of 80 cubic feet per hour. This should be sufficient to cool most applications requiring an air stream. In continuous welding operations, or applications with longer duty cycles, it may be necessary to cool the horn as well as the converter. Horns require cooling because of the cumulative residual heat that is transferred from contacting the workpiece.

Table 16 Converter Duty Cycle and Cooling

Max Power	% Duty Cycle	Duty Cycle ¹	Ambient Conditions ²
20 kHz			
4000 W	100% at 2000 W	10 seconds	Cooling air of 30° C @ 80cfh
	50% at 3300 W		
	25% at 4000 W		
30 kHz			
1500 W	100% at 800 W	2 seconds	Cooling air of 30° C @ 80scfh at 50° C ambient
	50% at 1500 W		
40 kHz 4TP Solid Mount Converter			
800 W	80% at 300 W	1 second	No cooling air, 40° C ambient
	40% at 700 W		
40 kHz 4TR, 4TH and 4TJ Converters			
800 W	100% at 600 W	1 second	Cooling air of 30° C @ 50scfh
	75% at 700 W		
	50% at 800 W		
	100% at 400 W	1 second	Cooling air of 30° C @ 25scfh
	70% at 600 W		
	40% at 800 W		
	60% at 400 W	1 second	No cooling air
20% at 700 W			

1. Maximum time for sonics on at the% of Duty Cycle.
2. Conditions at which data points were recorded

Testing the Installation, 4 Line Display

1. Turn on the air supply connections. For the 2000f system, include the pneumatic dump valve and verify that the air pressure indicator light in the actuator is lit.
2. Ensure there are no leaks in the air supply connections.
3. Turn on the power supply. The power supply will begins its normal self-check.
4. If the power supply displays an alarm message, find the alarm message definition in Chapter 7 of the power supply manual. If the power supply does not display any alarm messages and "Ready" appears in the power supply display, go on to the next step. Note that for 2000 ae/ao actuators, skip to Step 10.
5. Perform an actuator calibration by pressing the Main Menu button, and scrolling to Calibration. Verify that there is a minimum clearance from horn face to workpiece greater than 0.70".
6. Press the select key that corresponds to Calibration.
7. In the screen that follows, select the key that corresponds to Cal Actuator.
8. In the screen that follows, select the key that corresponds to w/Start Switches (Automation users select Manual Override).
9. Press the Start switches to complete the calibration.
10. Press the **Test** button.
11. If the power supply displays an alarm message at this point, find the alarm message definition in the Maintenance section of Chapter 7 of the power supply manual. If there are no alarm messages displayed, go on to the next step.
12. Fit a test part onto the fixture.
13. Press the **Horn Down** key and then press and hold the two start switches. The horn will descend to the fixture on the base of the Actuator. This verifies specifically that the pneumatic system is working.
14. Press the **Horn Down** key again. The horn will retract. The system should now be functional and can be set up for your application.

In summary, if the power supply does not display an alarm message and the descends and retracts correctly, your ultrasonic welder is ready for operation.

Figure 31 Normal VFD 4 Line Front Panel Display after Power-up

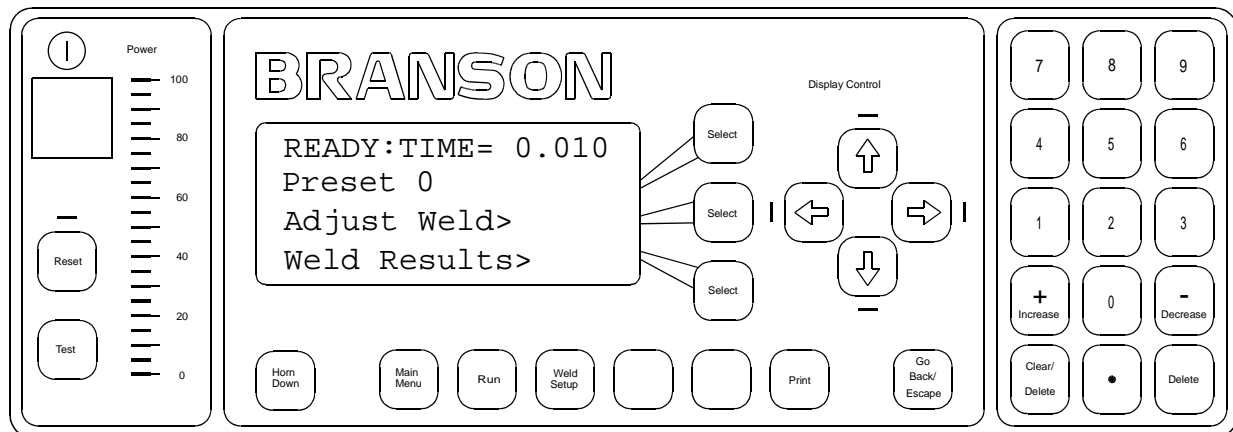

Testing the Installation, Touch Screen

1. Turn on the air supply connections including the pneumatic dump valve and verify that the air pressure indicator light in the actuator is lit.
2. Ensure there are no leaks in the air supply connections.
3. Turn on the power supply. The power supply will begin its normal self-check.
4. If the power supply displays an alarm message other than Recalibrate Actuator, find the alarm message definition, cause and correction in Chapter 7 of this manual. If the power supply displays the alarm message Recalibrate Actuator, or "Ready" appears in the power supply display, go on to the next step.
5. Perform an actuator calibration by touching the Main Menu button, and then touch the Calibration button. Verify that there is a minimum clearance from horn face to workpiece greater than 0.70".
6. Touch Cal Actuator.
7. In the screen that follows, touch w/Start Switches (Automation users select Manual Override).
8. Press the Start switches to complete the calibration.
9. Press the **Test** button.
10. If the power supply displays an alarm message at this point, find the alarm message definition in the Maintenance section of Chapter 7 of the power supply manual. If there are no alarm messages displayed, go on to the next step.
11. Fit a test part onto the fixture.
12. Touch **Horn Down** on the Main Menu. The horn will descend to the fixture on the base of the Actuator. This verifies specifically that the pneumatic system is working.
13. Press the **Retract** button or any of the 4 buttons on the bottom row. The horn will retract. The system should now be functional and can be set up for your application.

In summary, if the power supply does not display an alarm message and the descends and retracts correctly, your ultrasonic welder is ready for operation.

Figure 32 Normal Touch Screen Front Panel Display after Power-Up

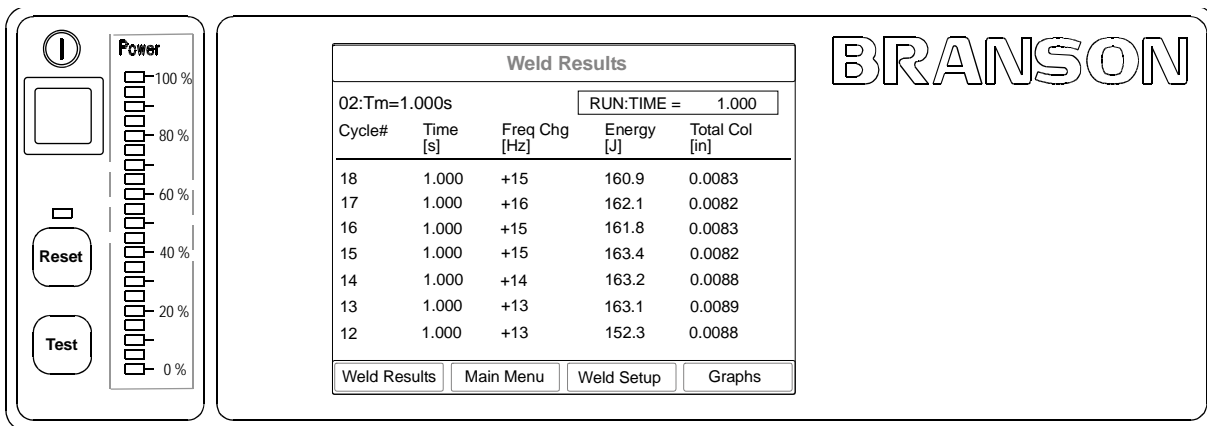

Still Need Help? or Parts? Have Questions?

Branson is pleased that you chose our product and we are here for you! If you need assistance with your 2000-series system, call your local Branson representative or contact Branson by calling, and asking for the appropriate department as indicated in the following table:

Table 17 *Whom to Call for Help*

What you need help with or information about. . .	Who to Call	At this Phone Number
Information about new welding systems or components	Your local Branson Rep or Branson Customer Service	203-796-0400 Ext 384
Application and Setup questions on the welding system	Welding Applications Lab	203-796-0400 Ext 368
Application assistance on the Horns and Tooling	ATG Lab	203-796-0400 Ext 495
Technical questions about the welding system	Welding Product Support	203-796-0400 Ext 355
Technical questions about Horns and Tooling	ATG Lab	203-796-0400 Ext 495
Ordering new parts	Parts Store	877-330-0406
RGA's, Request for Repair, Status of a Repair	Welding Repair Department	877-330-0405
System Automation/Hookup Information	Product Support	203-796-0400 Ext 355

My Local Branson Representative's name is:

I can reach this representative at:

Index

A

Actuator Mounting Bolts	7
Actuator Weights-	7
ae/aed Actuator Dimensional Drawing	-13
aef Actuator Dimensional Drawing	-14
Air Filter	-17
Allen wrench	
M8	7
ao/aod Actuator Dimensional Drawing	-15
Assemble the Acoustic Stack-	-40
For a 20kHz System	-41
For a 30 kHz System	-41
For a 40 kHz System	-42
Assembling the 20 kHz Acoustic Stack	-43

C

Cables-	8
Connecting Tip to Horn-	-44
Connection Codes	
Start Switch-	-30
Converter Duty Cycle and Cooling	-48

D

Data Receive	-31
Data Send	-31
DB-9 format connector	-31
Dimensional Drawing	
ae/aed Actuator-	-13
aef Actuator	-14
ao/aod	-15
ao/aod Actuator-	-15
Power Supply-	-13
Remote Pneumatics Box	-16
DIP Switch (SW1), Functions-	-35
DIP Switch Position, User I/O	-35
DIP switch SW1	-32

E

Emergency Stop Button	
reset - - - - -	-36
Emergency Stop Connection - - - - -	-30
Emergency Stop Control - - - - -	-36
Emergency Stop Switch Connections- - - - -	-30

F

Factory Air - - - - -	-17
Factory default setting	
for DIP Switches - - - - -	-35
Fixture Bolts and Washer - - - - -	7

G

Ground Detect - - - - -	-29
Guards and Safety Equipment - - - - -	-36
Emergency Stop Control - - - - -	-36

H

Handling and Unpacking - - - - -	3
Actuator (alone)- - - - -	6
Stand (actuator on a base) - - - - -	4
Stand (actuator on a hub) - - - - -	5
Unpack the Power Supply- - - - -	3
Unpack the Stand or Actuator - - - - -	3
Host Computer- - - - -	-31

I

Input Power (Main)-	-28
Input Power Plug-	-34
Installation Requirements	9
Air Filter	-17
Electrical Input Power Ratings-	-10
Environmental Specifications	9
Factory Air	-17
Location	9
Pneumatic Connections to Actuator ae/aed/aef	-18
Pneumatic Connections to Actuator ao/aod/rp	-18
Pneumatic Tubing and Connectors	-17
Installation Steps-	-18
Actuator (alone)-	-25
Input Power (Main)	-28
Interconnect between Power Supply and Actuator	-27
Mount the Power Supply	-27
Mounting the Stand (Actuator on Base)	-18
Mounting the Stand (Actuator on Hub-mounted column)	-24
Output Power (RF Cable)	-29
Installing the Ultrasonic Stack in the Actuator	-44
15, 20 and 30 kHz Stacks	-44
40 kHz Stacks	-46
Interconnect between Power Supply and Actuator	-27
International Harmonized Line Cord Color Code	-34
Inventory of Small Parts	7

L

Leveling Fixture Setup	-19
Horn, Part, and Fixture Alignment	-22
Preliminary Setup-	-19
Setup-	-22

M

Mount the Power Supply	-27
Mounting the Fixture on the Branson Base (hardware and mounting holes-	-47
Mylar Washer Kit-	7

O

Output Power (RF Cable) - - - - -	-29
Output Signal - - - - -	-35

P

Parallel Printer Connector - - - - -	-31
Pneumatic Connections to Actuator ae/aed/aef - - - - -	-18
Pneumatic Connections to Actuator ao/aod/rp - - - - -	-18
Pneumatic Tubing and Connectors - - - - -	-17
Power Supply Dimensional Drawing - - - - -	-11
Printer Compatibility - - - - -	-31
Printer Connector - - - - -	-31

R

Rack Mount Installation - - - - -	-38
Remote Pneumatics Box Dimensional Drawing - - - - -	-16
RS-232 - - - - -	-31
RS-232c - - - - -	-31

S

Safety - - - - -	2
Guards - - - - -	-36
Serial (RS-232) Port - - - - -	-31
Serial (RS-232) Port Connector - - - - -	-31
Signal Description - - - - -	-35
Spanners - - - - -	7
Special Cable requirements - - - - -	-28
Stack Assembly Torque Tables- - - - -	-43
Start Switch Connection (Automation) - - - - -	-30
Start Switch Connection (Automation) - - - - -	-30
Start switch/E-stop connections - - - - -	-30
Still Need Help? or Parts? Have Questions? - - - - -	-51
Stop button - - - - -	-36
Stud Torque Values - - - - -	-43

T

Testing the Installation, 4 Line Display	-50
Testing the Installation, Touch Screen	-51
T-Handle Wrench	7
Torque	-41

U

Unpack	3
Actuator (alone)	6
Power Supply	3
Stand (actuator on a base)	4
Stand (actuator on a hub)	5
Stand or Actuator	3
User I/O Cable Pin Assignments	-32
User I/O DIP Switch	-35
User I/O Interface	-32
