

These operating instructions are delivered with each product. Malfunctions, damage or injury may occur if these instructions are not followed.

Description

Series 642 Air Filter Regulators are designed for use in potentially explosive atmospheres caused by gases, vapors, mists and/or dusts as per ATEX Directive 2014/34/EU and standards EN ISO 80079-36. UKSI Regulation 2016 : 1107 (as amended by UKSI 2019:696)- Annex 3A, Part 1 after ATEX directive and BS EN ISO 80079-36 (2016)

Classification (Zone 1 and 21): II 2 G Ex h IIC T5 Gb, II 2 D Ex h IIIC T5 Db
 The Classification temperature depends on the ambient temperature. These regulators are made of external metal parts & internal with plastic/metal parts.

Startup and maintenance are to be performed as detailed below.

General

This component is not a safety accessory. It is intended only for the compliant use either as an individual component or incorporated in an apparatus, machinery and installations. Filter Regulators are designed to be operated in accordance with the limits specified in the nameplate or as specified in this document. All applicable directives, legislations, orders and standards, as amended from time to time, as well as state-of-the-art practices and procedures must be observed for intended scope of application of the product. Where applicable take all appropriate measure to ensure the requirements are met. This device complies with the essential safety requirements of the EU PED 2014/68/EU. Declaration of conformity is available on request.

All assembly, operation, use and maintenance must be performed by qualified, authorized personnel. Personnel working with the components must be familiar with the applicable safety and regulations relating to the components, apparatus and machinery installations. In case of problems, please contact ASCO or one of its authorized representatives in your region.

General Operating Specifications

Fluid: Instrument air

Ambient Temperature: For manual drain: the temperature range should be within -40° C to + 90° C (-40°F to +194°F); For Auto drain: the range should be within +1° C to + 80° C (34°F to +176°F).

Inlet Pressure: Do not exceed the maximum operating pressure 20 bar(290psi) for manual drain FR, 17bar(247psi) for auto drain FR.

Installation

Check the preliminary storage conditions required for the component. They must be in accordance with the product's specifications.

Carefully remove the Filter Regulator from the packaging.

Power off and depressurize the apparatus, machinery or installation designed to receive the FR.

Install the FR near where the air is to be used.

Install ASCO pressure gauge comes accessory on the gauge port. & Do Not modify the device.

Make sure that the fluid is compatible with the materials it contacts.

Operator or user must ensure that the gas group corresponds to the product's classification.

Check Nameplate for correct catalog number, pressure, temperature and service. Never apply incompatible fluids or exceed pressure rating of the regulator.

The installer must install the air filter regulator at the user's location in accordance with the requirements specified in Directive 99/92/EC.

Positioning

 **For optimum life and performance, the FR should be mounted vertically upright (Max. Inclination 5°).**

Piping

Connect piping to valve according to markings on FR body. Apply pipe compound sparingly to male pipe threads only. If applied to FR threads, the compound may enter the FR and cause functional difficulty. Avoid pipe strain by properly supporting and aligning piping. When tightening the pipe, do not use the FR as a lever. Locate wrenches applied to piping as close as possible to connection point.

Direct Frontal mounting or mounting with brackets possible.

Maintenance

NOTE: Ensure the air supply is completely stopped. It is not necessary to remove the FR from the pipeline for repairs.

Cleaning

All FRs should be cleaned periodically. The time between cleanings will vary depending on the medium and service conditions. The most common part that requires cleaning is the filter element.

Use running water for regular cleaning or a mild detergent for cleaning the filter element. Do not use diluted acids, strong detergents or corrosive chemicals.

For auto drain version clean the filter ring periodically.

Causes of Improper Operation

Incorrect pressure: Check upstream pressure. Pressure to FR must be within range specified on nameplate.

Excessive Leakage: Disassemble FR and clean all parts. If parts are worn or damaged, install a complete ASCO Spare Parts kit.

Manual drain operation:

Hold the knurling face of drain with fingers & rotate it to the anti-clockwise direction looking from top to unscrew the manual drain to purge out the water that accumulated in the bowl. After draining out, screw the manual drain back to its original position & ensure proper working of AFR.

Earthing:

The earth is connected to the unit or to the combination of conditioning units by the downstream and upstream use of metal pipes connected to the earth. If the pipes are non-conductive, earth connection should be performed by the assembly and/or fixing devices adapted to the ATEX products.

Automatic draining:

Auto drain provides hassle free draining of equipment which purge out the water accumulated in the bowl automatically. It also provides manual drain feature integrated with automatic drain. Anti-clockwise to drain & clockwise to close drain when looking from top view.

FR DISASSEMBLY

1. Disassemble FR in an orderly fashion using exploded views for identification and placement of parts. Refer to figure 1.
2. Remove bowl from the body (as shown in fig. 17) and the remove bowl seal
3. Unscrew the filter assembly by hand itself
4. Carefully unscrew the bowl baffle in filter assembly and remove filter element for cleaning
5. For normal maintenance(cleaning) it is not necessary to remove the poppet assembly. However, if poppet assembly removal is required, just pull it out of the body.
6. Remove the manual drain/auto drain from the bowl
7. Remove the bonnet from the body by unscrewing the M6 fasteners and remove top spring and diaphragm assembly.
8. All parts are now accessible to clean or replacement. If parts are worn or damaged, install a complete ASCO Spare Parts Kit.

- Service Notice -

When installing a new ASCO spare parts kit, the parts supplied are shown in Figure. A. The parts supplied are new and a direct replacement for the present parts provided all news parts are installed.

CAUTION: To ensure proper valve operation, install all parts supplied in ASCO Spare Parts Kit. Do not mix old and new parts.

FR REASSEMBLY

1. Lubricate all gaskets with CERAN LT lubricant or an equivalent low temperature silicone fluid.
2. Add a layer of NEVERSEEZ – 160S on all screw threads
3. If removed, install poppet assembly in body. Apply a small amount of NEVERSEEZ – 160S to filter sub assembly threads. Hand tight the assembly as far as possible. No special tool is required to provide torque
4. Install diaphragm assembly, springs, spring disc and bonnet on top. Secure the bonnet on top of the body by tightening the M6 fasteners
5. Replace manual drain/auto drain on bowl and assemble bowl on bottom side of the body (as shown in fig. 18).
6. Install FR in vertical position.

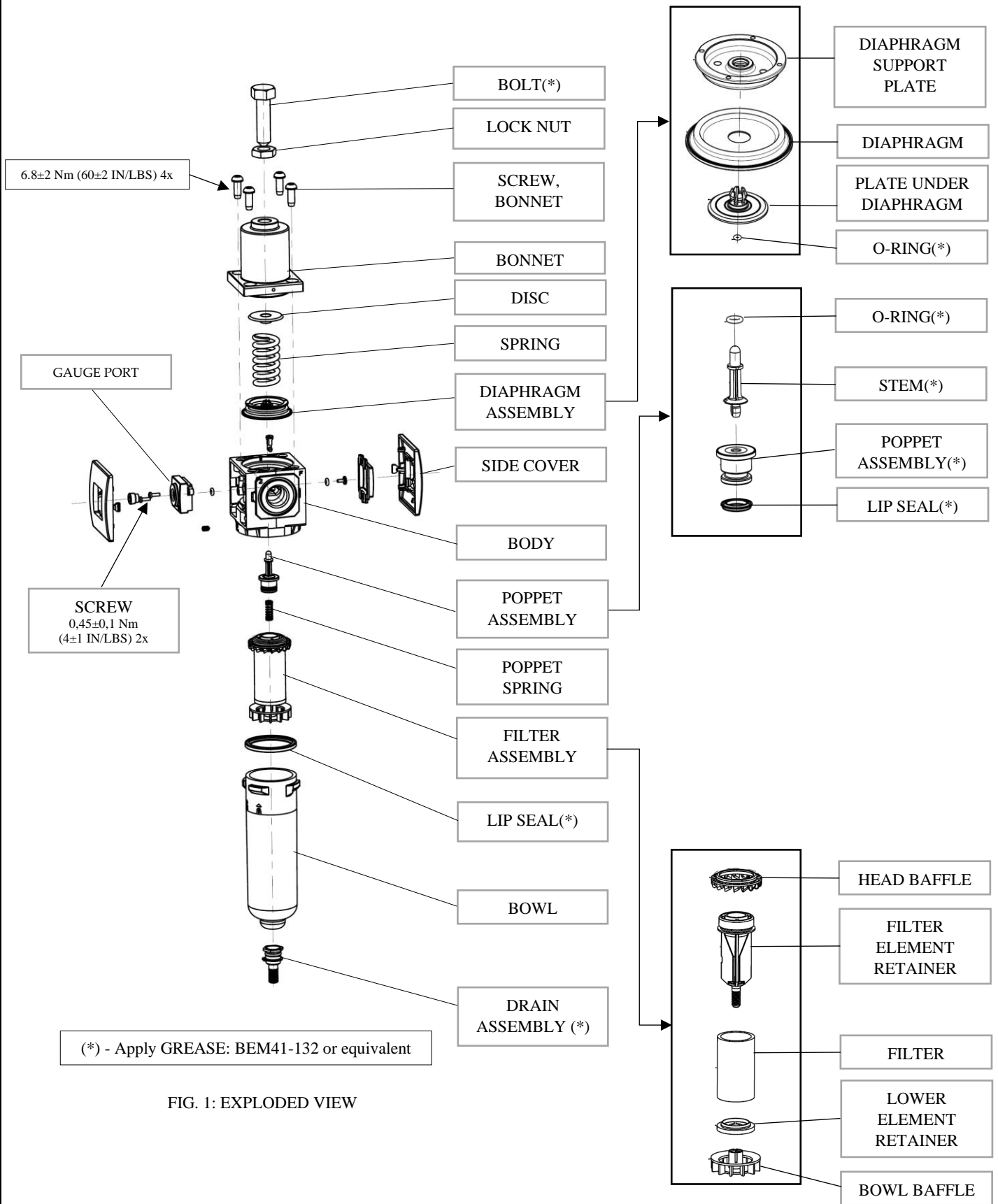

FIG. 1: EXPLODED VIEW

TECHNICAL DETAILS	642
TEMP, STANDARD, NBR (°C)	-40 TO +90
TEMP, FKM (°C)	-20 TO +80
TEMP, LOW TEMP (°C)	NA
TEMP, AUTO DRAIN (°C)	+1 TO +80

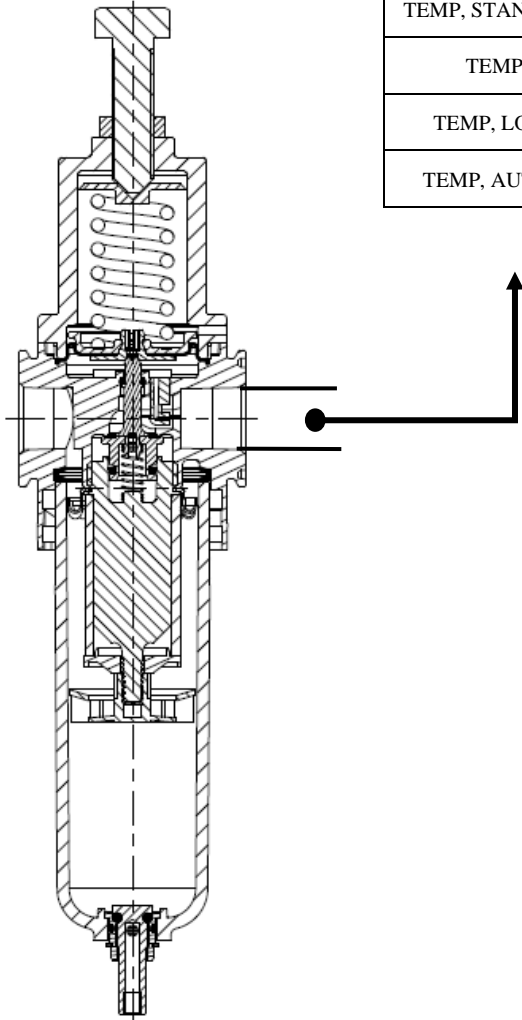

FIG. 2: FR SECTIONAL VIEW

FIG. 4: LABEL

MOUNTING



FIG. 5: ASSEMBLED VIEW

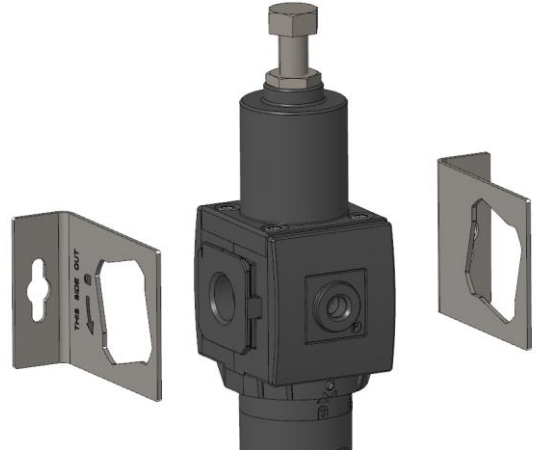

FIG. 6: DISASSEMBLED VIEW

GAUGES

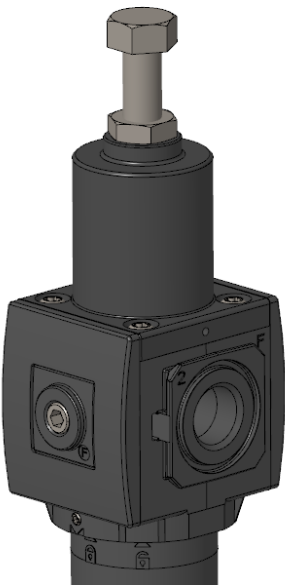

FIG. 7: WITHOUT GAUGE

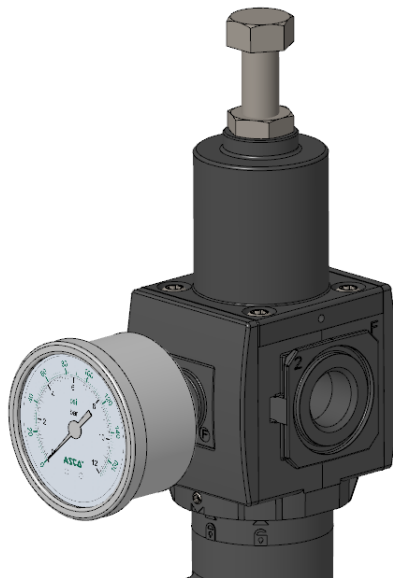

FIG. 8: WITH SS GAUGE

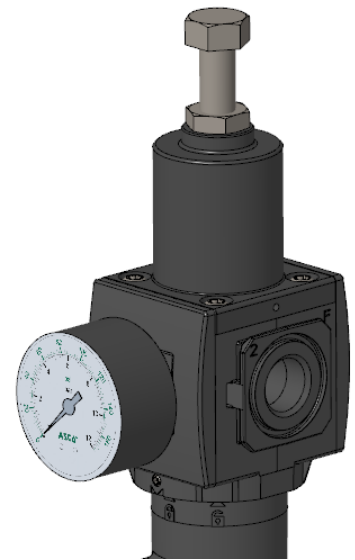
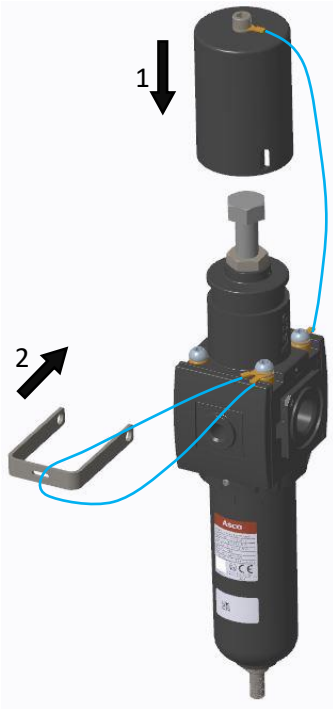

FIG. 9: NON-SS GAUGE

TAMPER PROOF

ASSEMBLY (FIG 11)



FINAL ASSEMBLY (FIG 10)



DIS ASSEMBLY (FIG 12)

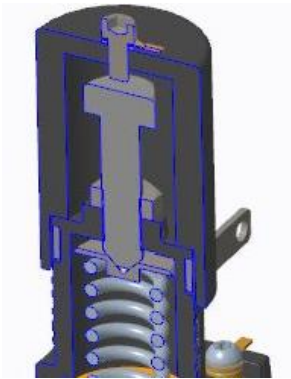
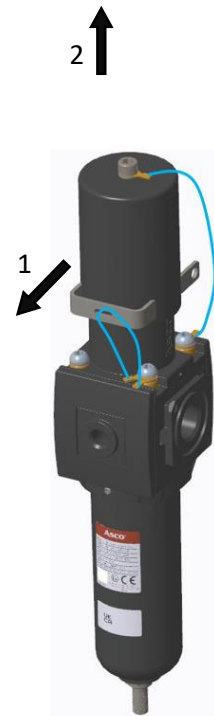

FIG. 14: PARTIAL SECTIONAL VIEW

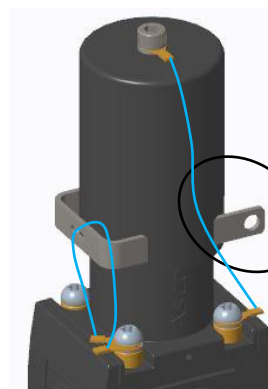

FIG. 13

T- HANDLE

REGULAR

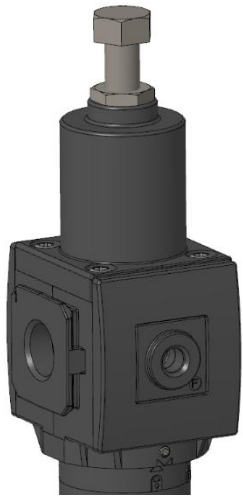

FIG. 15

T - HANDLE TYPE



CLOCKWISE TO SET
PRESSURE (FROM TOP VIEW)

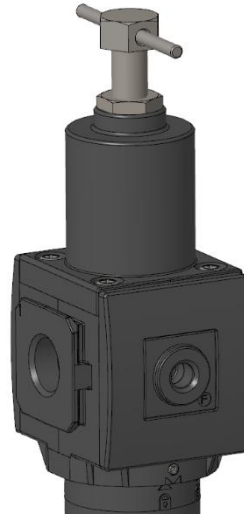

FIG. 16

DISASSEMBLY

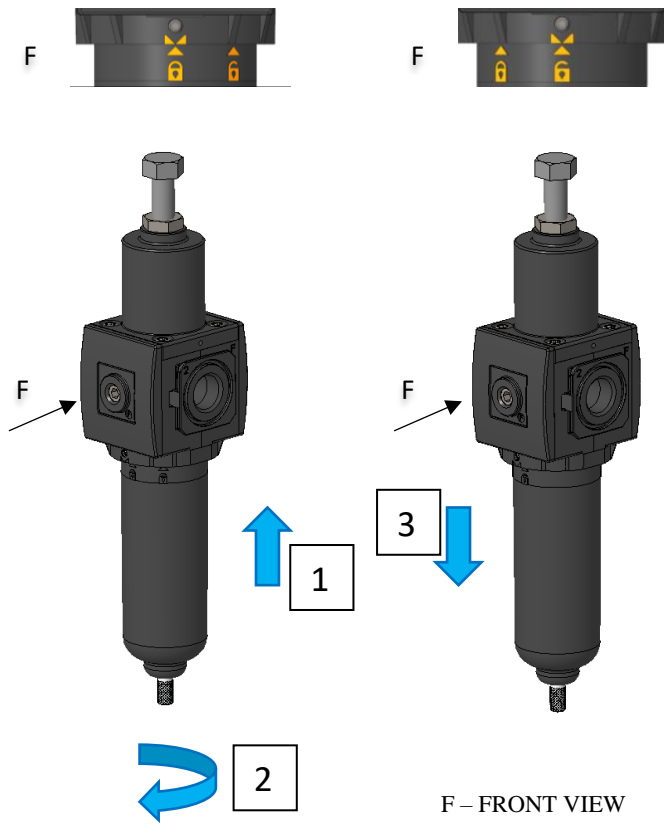

FIG. 17

ASSEMBLY

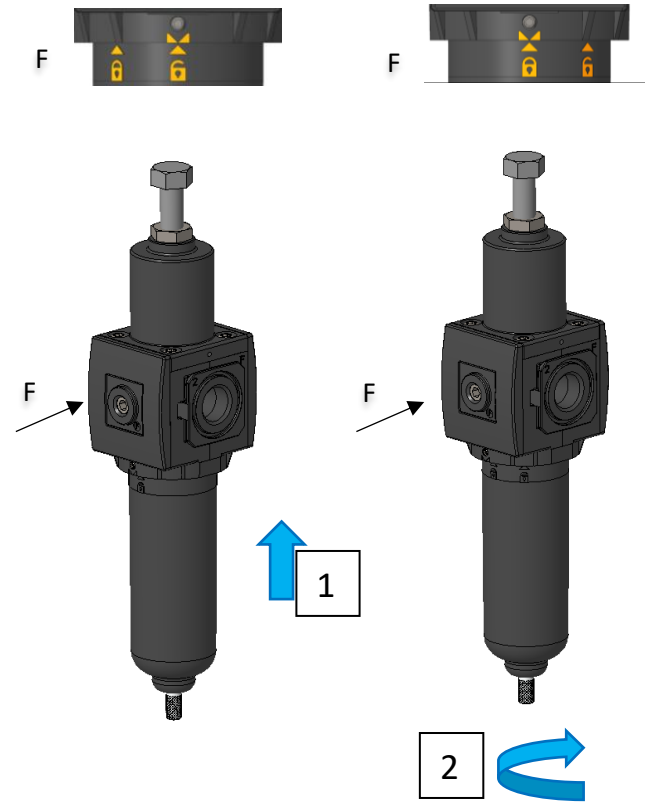

FIG. 18

DRAINS



METAL MANUAL DRAIN
 (Brass/stainless steel)

- TEMPERATURE: -40°C ... +90°C
- Min. INLET PESSURE (P1 Min.): 0 Bar
- Max. INLET PRESSURE (P1 Max.): 20 Bar

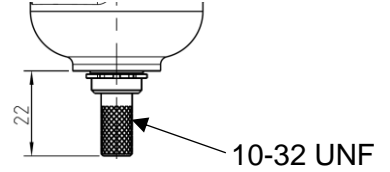

Automatic Drain NC/NO

- TEMPERATURE: +1°C ... +80°C
- Min. INLET PESSURE (P1 Min.): 0.5 to 1.0 Bar
- Max. INLET PRESSURE (P1 Max.): 17 Bar

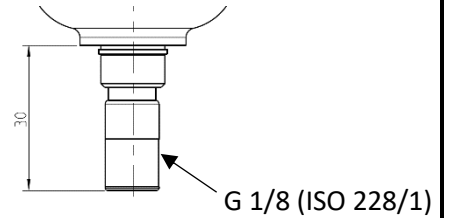

FILTERS

PE			
Filtration	5 µm	25 µm	40 µm
Colour	White	Yellow	Green

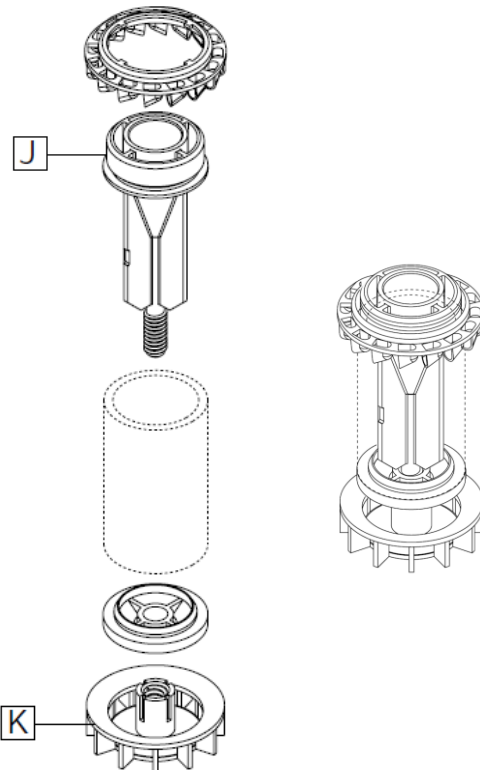

ITEMS	N.m	Inch.pounds
J	1.1±0.2	10±2
K	0.45±0.1	4±1

642 SERIES**USABLE IN ATEX ZONES**

FIG. A



SCREW (1), BOWL (2), BODY (3),
BONNET (4), DRAIN (5), AND BOLT
(6) ALL ARE METAL PARTS

FIG. B

This product category does not fall within the scope of the ATEX 2014/34 / EU directive: the risk analysis according to the EN ISO 80079-36 standard has shown that no potential source of ignition specific to the products are effective. These products can be used in specific explosion zones 1 and 21 in compliance with our installation instructions:

* List of affected components

- Mounting components
- Assembly and connection components
- Mechanical accessories
- Filter

These conditioning units of compressed air and their accessories are capable for use in explosive atmospheres in the form of gas, steam, mists and dust.



SPECIAL CONDITIONS FOR SAFE USAGE:

Risk from electrostatic charges

Prevent electrostatic charging of external insulating surfaces by using the appropriate installation and cleaning measures. To clean external insulating surfaces, use a damp cloth.

Connect the conditioning units to the earth.

When combined with other conditioning units, ensure that all metallic and conductive parts are always interconnected and linked to the earth to avoid significant electrostatic charges being created.

The earth is connected to the unit or to the combination of conditioning units by the downstream and upstream use of metal pipes connected to the earth. If the pipes are non-conductive, earth connection should be performed by the assembly and/or fixing devices adapted to the ATEX products.

Installation, commissioning and servicing and maintenance

These operations may only be carried out by authorised personnel and in accordance with the usage instructions.

Only carry out maintenance in zones where there is no explosive atmosphere.

If during maintenance it is established that wearing and spare parts need exchanging, contact an ASCO Numatics or AVENTICS reseller.

Any modification of the product with parts not supplied by the manufacturer will invalidate the certification.

Filter equipped with a metallic bowl: (see fig. B)

When replacing a filter element saturated by the filter, proceed as described below:

- Loosen the screw (1)
- Remove the bowl (2) from the body (3)
- Remove the filter element and replace with a new one
- Assemble the bowl (2)
- Tighten the screw (1) in the body (3) up to the contact of the bowl and screw one quarter to a half turn extra in order to ensure ground continuity.