

	<h1 style="margin:0;">Installation & Maintenance Instructions</h1> <p style="margin:0;">Advanced Redundant Control System (ARCS) Direct Acting Platform</p>	<p>SERIES</p> <p>141</p>
---	---	--

User Experience Prerequisites

To effectively use the Pneumatic ARCS, users should have some experience with pneumatic systems.

Warnings!

READ THIS ENTIRE MANUAL AND ALL RELATED PUBLICATIONS PERTAINING TO THE WORK TO BE PERFORMED BEFORE INSTALLING, OPERATING OR SERVICING THIS EQUIPMENT.

- Follow all appropriate safety codes and standards.
- Failure to follow instructions may result in personal injury and/or property damage.
- Use extreme caution when working around power-input cables. These cables may have potentially lethal or dangerous voltages.
- Prior to energizing the equipment, have qualified personnel verify all wiring and connections against vendor drawings. Incorrect wiring and/or connections can result in equipment damage or serious system failure. If you have questions or need more information on installing and operating ASCO equipment, contact ASCO.

PRODUCT DESCRIPTION

The Advanced Redundant Control System as ARCS is solenoid operated valve system designed for use as a component in safety instrumented systems. It functions as a redundant pneumatic tripping device to control the pilot air signal to a process valve actuator. The ARCS uses 1oo2, 2oo2 or 2oo3 voting solenoids to enhance the reliability of the circuit. The ARCS consists of two or four electrically actuated solenoid valves (V1, V2, V3 & V4) and a pneumatically operated (Manually Controlled) bypass valve or isolation valve, and visual Indicators, Pressure switches. The pressure switches provide solenoid state feedback and are used during on-line testing of the ARCS unit. The bypass valve or isolation valve allows for maintenance of the solenoid valves without having to shut down the process valve. The use of the Maintenance Bypass/Isolation valve is not required for functional testing of the ARCS unit.

Under normal operating conditions:

The ARCS allows for periodic testing of the solenoids by cycling one solenoid valve automatically therefore attaining the desired safety availability. This testing is performed online without the need for bypassing/Isolating of the safety action and without interruption of the process.

The ARCS supplies air to the process valve actuator through the “Process” port when energized.

When a trip occurs:

The ARCS blocks the incoming pneumatic signal and connects the “Process” port to the “Exhaust” port. This vents the air signal from the process valve actuator and allows the actuator return spring to move the process to its fail-safe position.

SPECIFICATIONS:

Manifold Architecture: Normally Closed
System Voltage: 12 VDC, 24 VDC, 48VDC, 120 VDC, 120/60-110/60 VAC or 230/50-240/50 VAC.
Operational Mode: De-Energized to trip.
Optional Features: Visual Indicators/Pressure gauge, Pressure switches.

Differential pressure: 0/1 - 10 bar [1 bar = 100kPa]

Maximum viscosity: 65 cSt (mm²/s)

Response time: 75 - 100 ms

Fluid: Dry & Non Lubricated Air

NOTE: Filtered (5 micron) instrument air recommended

Temperature Range (TS): -20°C to +60°C

Seal Materials: FPM

Pneumatic Valve:

3/2 solenoid operated valve.

Bypass Valve:

5/2 manually operated valve

Isolation Valve:

3/2 manually operated valve

Visual indicators:

Red – Air not available

Green – Air available

Pipe Size	Operating Pressure		Power Level	Prefix Solenoid Options										Operation	Fluid Temperature Ts ⁽³⁾ (°C)	Material of Construction	Basic Solenoid Valve	Basic Ordering Code for Solenoid Valve				
				NPT	MIN	MAX	-/+	Exd m			Exd								Exi		IP67	IP65
								VCEF	NF / WSNF	WSCR	EM / WSCREM	NFIS / WSCRIS	WSTIS						WP / WS	SC		
1/4" or 1/2"	0/1 ⁽²⁾	10	BP	•												Auto Reset	-20 to +55	SS316L	327G042	536408		
				•													Manual Reset	-20 to +55	SS316L	327G032	536407	
			MP		•	•	•						•	•	Auto Reset	-20 to +90	SS316L	327B202	536398			
					•		•						•	•	Auto Reset	-20 to +90	Aluminium	327B203	536403			
			RP		•								•	•	Auto Reset	-20 to +90	SS316L	327B232	536401			
					•	•	•						•	•	Auto Reset	-20 to +90	SS316L	327B102	536397			
			LP		•								•	•	Auto Reset	-20 to +90	Aluminium	327B103	536402			
					•										Auto Reset	-20 to +60	SS316L	327H102	536404			
				•									•	•	Manual Reset	-20 to +90	SS316L	327B132	536400			
				•											Manual Reset	-20 to +60	SS316L	327H132	536409			
				•											Auto Reset	-20 to +90	SS316L	327B302	536399			
				•											Auto Reset	-20 to +90	Aluminium	327B303	536405			
	•											Manual Reset	-20 to +90	SS316L	327B332	536406						
										•		Auto Reset	-20 to +60	SS316	307B005 ⁽¹⁾	503838						

⁽¹⁾ For detail specification and dimensions, please refer to ASCO representative
⁽²⁾ Zero bar applicable for redundant configuration without online maintenance and diagnostic feature options only
⁽³⁾ Can be limited by the operator ambient temperature range for explosion proof solenoids

ELECTRICAL CHARACTERISTICS

Prefix	Inrush (~)	Holding (~)	Power Rating		Operator Ambient temperature Range (°C)	Safety Code	Coil Insulation Class	Electrical Enclosure Protection (EN60529)
	VA	VA	(~)	Hot/Cold =				
			W	W				
Basic Power (BP)								
VGEF	12	12	12	11.6	-20 to +55	II 2GD Ex db mb IIC T ⁺ Gb Ex mb tb IIIC T ⁺ °C Db	F	IP66/67, Alu
Medium Power (MP)								
(NF/WSNF/WSGR)	5.8	5.8	5.8	5.2/5.7	-60 to +40/75/90	II2G Ex d IIC Gb T6/T5/T4, II2D Ex t IIIC Db	H	IP66/67, Alu/SS
EM	5.8	5.8	5.8	5.2/5.7	-60 to +40/75/90	II2G Ex eb mb IIC Gb T6/T4, II2D Ex tb IIIC Db	H	IP66/67, steel
WSGREM	5.8	5.8	5.8	5.2/5.7	-60 to +40/75/90	II2G Ex eb mb IIC Gb T6/T4, II2D Ex tb IIIC Db	H	IP66/67, SS
WP/WS	5.8	5.8	5.8	5.2/5.7	-60 to +90	EN 60730	H	IP66/67, steel/SS
SC	5.8	5.8	5.8	5.2/5.7	-60 to +90	EN 60730	F	IP65, moulded
Reduced Power (RP)								
(NF/WSNF/WSGR)	3.7	3.7	3.7	3.2/3.6	-60 to +60	II2G Ex d IIC Gb T6/T5/T4, II2D Ex t IIIC Db	H	IP66/67, Alu/SS
EM	3.7	3.7	3.7	3.2/3.6	-40 to +40/55	II2G Ex eb mb IIC Gb /T5/T4, II2D Ex tb IIIC Db	H	IP66/67, steel
WSGREM	3.7	3.7	3.7	3.2/3.6	-60 to +40/60/90	II2G Ex eb mb IIC Gb T6/T5/T4, II2D Ex tb IIIC Db	H	IP66/67, SS
WP/WS	3.7	3.7	3.7	3.2/3.6	-60 to +55	EN 60730	H	IP66/67, steel/SS
SC	3.7	3.7	3.7	3.2/3.6	-60 to +55	EN 60730	F	IP65, moulded
VGEF	-	-	-	3.9	-40 to +55/60	II 2 G D Ex d mb IIC T6/T5 Gb, Ex mb tb IIIC T6/T5 Db IP 67	H	IP66/67, Alu
Low Power (LP)								
(NF/WSNF/WSGR)	1.85	1.85	1.85	1.5/1.8	-60 to +55	II2G Ex d IIC Gb T6/T5, II2D Ex t IIIC Db	H	IP66/67, Alu/SS
WSGREM	1.85	1.85	1.85	1.5/1.8	-60 to +55	II2G Ex eb mb IIC Gb T6/T5, II2D Ex t IIIC Db	H	IP66/67, SS
Intrinsically Safe (IS)								
(NFIS/WSNFIS/WSGRIS)	-	-	-	0.5	-40 to +60	II2G Ex ia IIC Gb T6, II2D Ex t IIIC Db	H	IP66/67, Alu/SS
WSTIS	-	-	-	0.4	-20 to +60	II2G Ex ia IIC Gb T6, II2D Ex t IIIC Db	H	IP66/67, SS

FLOW RATE

Flow at ANR	Inlet to Outlet		Outlet to Exhaust	
	ANR (lpm)	Kv	Flow (lpm)	Kv
2oo3	353	0.29	944	0.25
2oo2	497	0.39	851	0.23
1oo2	234	0.19	542	0.23

Note: Exhaust flow pressure at 6 bar, atmospheric pressure is 1 bar

Pressure Switches:

SPDT switches, Steel, galvanised.

Switching function-Selectable: Normally open, normally closed, change-over contact

Pneumatic Connections:

Inlet & Process:

¼" or ½" NPTF

Exhaust Port:

¼" NPTF

Approvals:

Exida

Certified SIL 3 capable

Lifting:

- Don't use valve body or enclosure to lift the system.
- Don't use Pressure switches or indicators to lift the system

⚠ WARNING: Explosion Hazard! Do not remove or replace any component while circuit is live unless the area is known to be non hazardous.

ASCO components are intended to be used only within the technical characteristics as specified on the nameplate. Changes to the equipment are only allowed after consulting the manufacturer or its representative. The solenoid valves of Advanced Redundant Control System with ATEX/IEE Ex certification is intended for installation in potentially explosive atmospheres, ATEX category 2G, gas Group IIC. The surface temperature classification depends on the voltage, wattage and ambient temperature which are stated on the nameplate. The ARCS should be mounted as closely to the process valve as possible. In order to insure proper operation of the process valve, tubing runs should be as straight and short as possible

Wiring Guidelines

The following general guidelines apply to all wiring discussed in this document.

⚠ WARNING: Circuit power must be removed from the device prior to disconnecting the wiring on either the field or internal side of the terminal strip.

- Wire size: stranded 16 and 18 AWG.
- The terminal clamps are designed for one wire only; DO NOT attempt to terminate multiple wires into one terminal.
- Use care when running signal wiring near to or crossing conduit or wiring that supplies power to motors, solenoids, lighting, horns, bells, etc.
- AC power wiring should be run in a separate conduit from DC power. All power wiring to and from the ARCS should be in grounded conduit.
- The ARCS should be connected to a high quality instrument grade ground with #14 AWG or heavier wire.

Electrical Connection (Customer Responsibility):

- In all cases follow local and national electrical codes and confirm compliance with Zone 1 ATEX requirements.
- It is recommended that standard industry practices are followed to prevent condensation from entering the enclosure and, in some cases of Class I, Div. 2 or ATEX Zone 1 conditions, to prevent hazardous gasses and vapors from migrating through the conduit to the control room or open ignition source.

REDUNDANT FUNCTIONS

- 1oo2 Manifold Assembly, without Online Maintenance & without Diagnostic
- 1oo2 Manifold Assembly, with Common By-pass & without Diagnostic
- 2oo2 Manifold Assembly, without Online Maintenance & Diagnostic
- 2oo2 Manifold Assembly, without Online Maintenance, with Diagnostic
- 2oo2 Manifold Assembly, with Common By-pass with Diagnostic
- 2oo2 Manifold Assembly, with Individual Isolation with Diagnostic
- 2oo3 Manifold Assembly, without Online Maintenance, without Diagnostic
- 2oo3 Manifold Assembly, without Online Maintenance, with Diagnostic
- 2oo3 Manifold Assembly, with Individual Isolation & with Diagnostic

1oo2 REDUNDANT VALVE SYSTEM

1oo2 is for safe exhausting. It is enough to close one of the two solenoid valves to exhaust the outlet. Each valve V1 & V2 are channel 1&2.

1oo2 Manifold Assembly, without Online Maintenance & without Diagnostic

1oo2 redundant valve system has two solenoid valves which are connected in series (Normally closed valve). Valve 1 outlet is connected to valve 2 inlet. Both valves are energized then outlet will supply air to actuator. Any one valve gets fail/de-energized system goes to vent position. Refer Fig-1 circuit and logic table.

⚠ CAUTION: De-energizing one or two valves will initiate a shutdown.

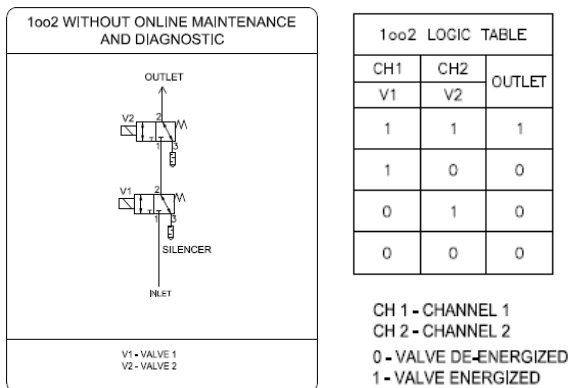

Fig: 1

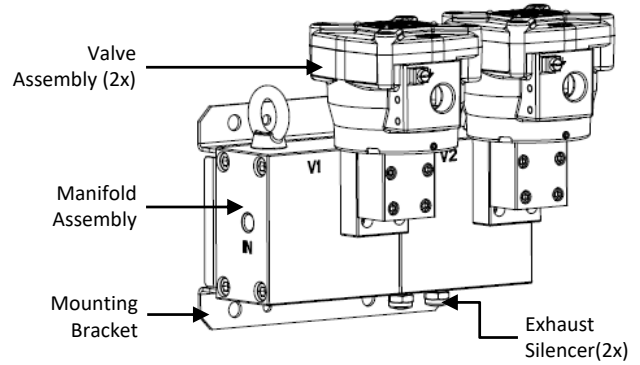

Fig: 1A

1oo2 Manifold Assembly, with Common By-pass & without Diagnostic: Bypass Mode

The manually operated maintenance bypass valve is used to isolate and depressurize the solenoid valves. This function allows to do maintenance of solenoid valve system without disturbing the outlet air supply. Refer Fig-2 circuit and logic table.

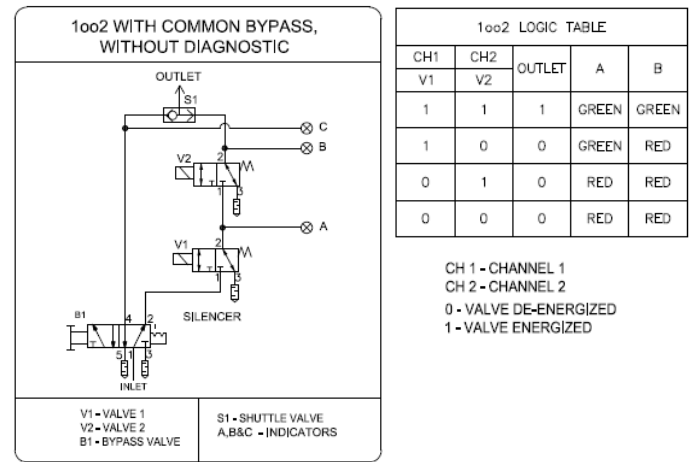

Fig: 2

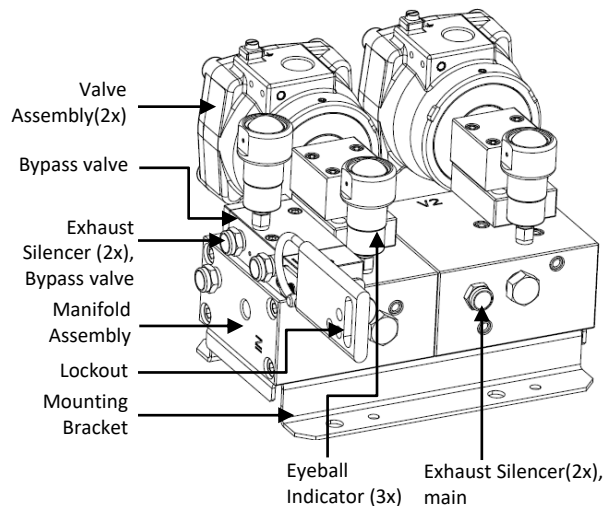

Fig: 2A

Fig: 2A shows 1oo2 Manifold assembly with common bypass, with visual indicator option

In “Normal” mode Bypass valve indicator will show red. When switching to “Bypass” mode Bypass valve indicator will show green.

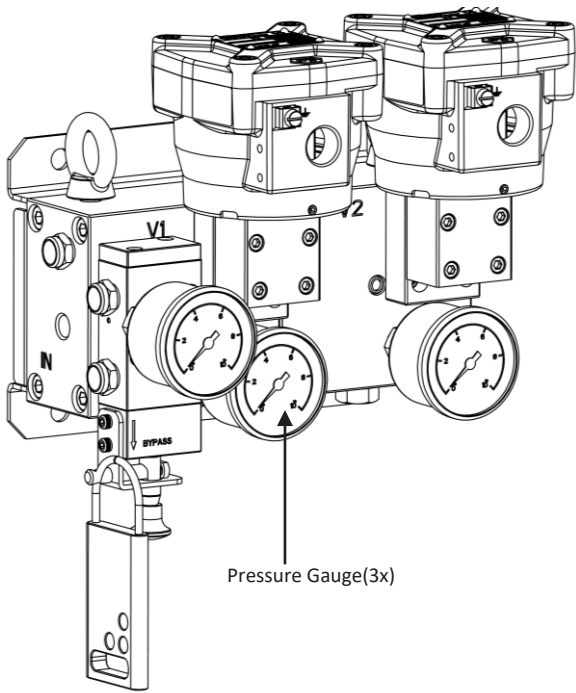

Fig: 2B

Fig: 2B shows 1oo2 Manifold assembly with common bypass with Pressure gauge option.

CAUTION: De-energizing one or two valves will initiate a shutdown.

Maintenance

The Pneumatic ARCS requires no routine maintenance except periodic inspections for loose wires and fittings. The solenoid enclosure should be opened occasionally and the components checked to make sure they are tight, clean, and dry. The Breather/Vent valve shall be inspected for obstruction and that it is free of debris during routine maintenance cycles and during manual proof testing.

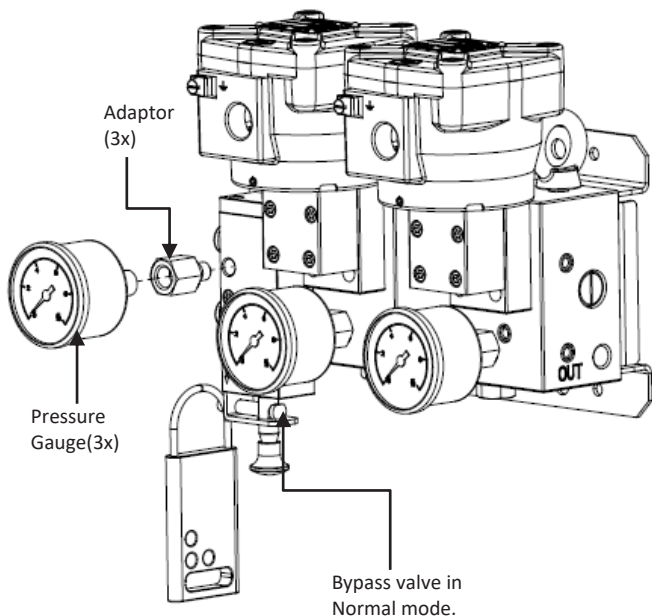

Fig: 2C

Manual Bypass valve operation (for maintenance only)

1. Remove the lockout and lock pin from the bypass valve.
2. Pull the knob downwards and put back the lockpin.
3. Put lockout and make it secured.
4. The system pressure is now bypassed directly from “inlet” to “outlet” so that the process valve position is maintained.
5. Verify the visual indicator/pressure gauge of bypass, it shows pressure availability.

WARNING: Secure the bypass valve operation until maintenance has been completed.

WARNING: Explosion Hazard. Do not remove or replace any component while circuit is live unless area is known to be non-hazardous.

6. Turn off power to the ARCS; disconnect appropriate wires from terminal block.
7. Remove device (coil or solenoid valve) and install the new device.
8. Re-connect wires to appropriate terminal, Turn on power to the ARCS. Verify that each device has power and is in the correct state.
9. Remove the lockout and lockpin; push the knob to upwards.
10. Put the lockpin, lockout and make it secured. Now system is in “normal” mode.

CAUTION: While placing valve on the manifold ensure that all O-rings(3x) are placed on the valve correctly.

CAUTION: While doing valve maintenance, Do not try to operate corresponding bypass or isolation valve. Which will make pressure drop and lead to fail safe condition of actuator.

2oo2 REDUNDANT VALVE SYSTEM

2oo2 is for increased availability. It is enough to open one of the two solenoid valves to supply the outlet. Each valve V1 & V2 are channel 1&2. Both solenoid valves must be close to fulfill safety function.

CAUTION: De-energizing two valves will initiate a shutdown.

2oo2 without online maintenance and diagnostic

2oo2 redundant valve system has two solenoid valves which are connected in Parallel (Normally closed valve). Any one valve gets fail/de-energized system does not go to vent position. Fig-3 shows circuit diagram and logic table.

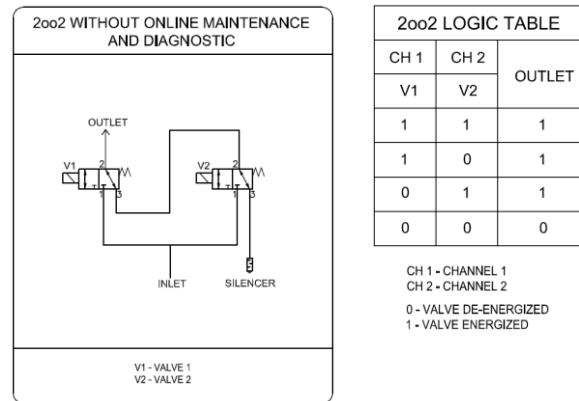

Fig: 3

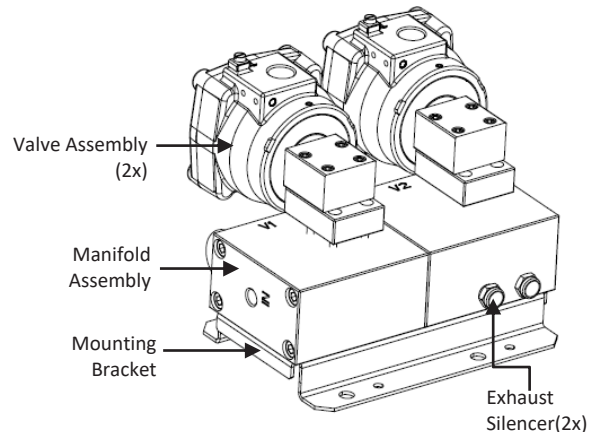

Fig: 3A



Installation & Maintenance Instructions

Advanced Redundant Control System (ARCS) Direct Acting Platform

SERIES
141

2oo2 without online maintenance and with diagnostic

Two valves are connected with shuttle valve. It has visual indicator and pressure switch options. Fig-4 & 4A shows circuit diagram and logic table.

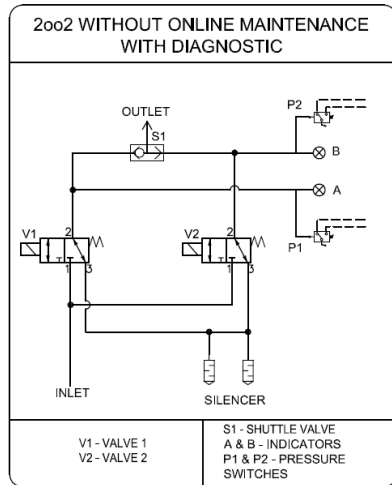
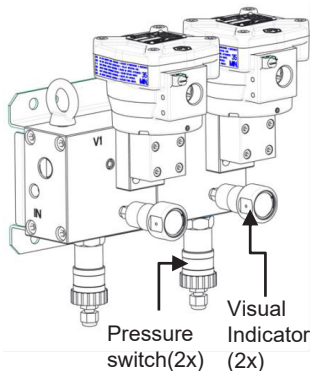

Fig: 4



2oo2 LOGIC TABLE				
CH1	CH2	OUTLET	A	B
1	1	1	GREEN	GREEN
1	0	1	GREEN	RED
0	1	1	RED	GREEN
0	0	0	RED	RED

CH 1 - CHANNEL 1
CH 2 - CHANNEL 2
0 - VALVE DE-ENERGIZED
1 - VALVE ENERGIZED

Fig: 4A

2oo2 with common bypass and with diagnostic

The manually operated maintenance bypass valve is used to isolate and depressurize the solenoid valves. This function allows to do maintenance of solenoid valve without disturbing the outlet air supply. Fig-5 shows circuit diagram.

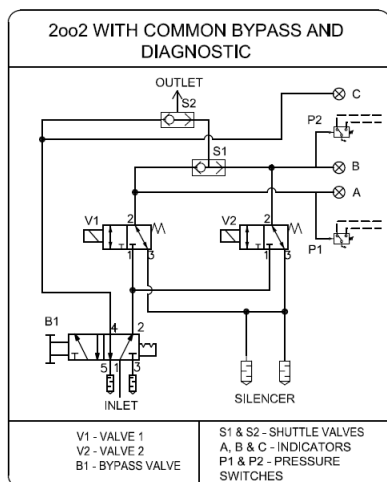

Fig: 5

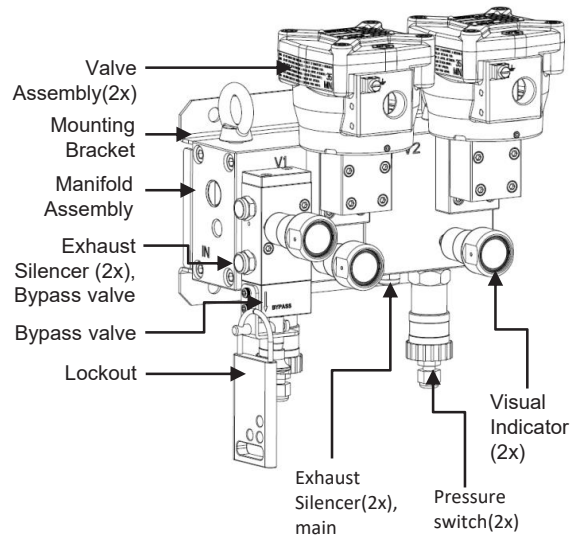

Fig: 5A

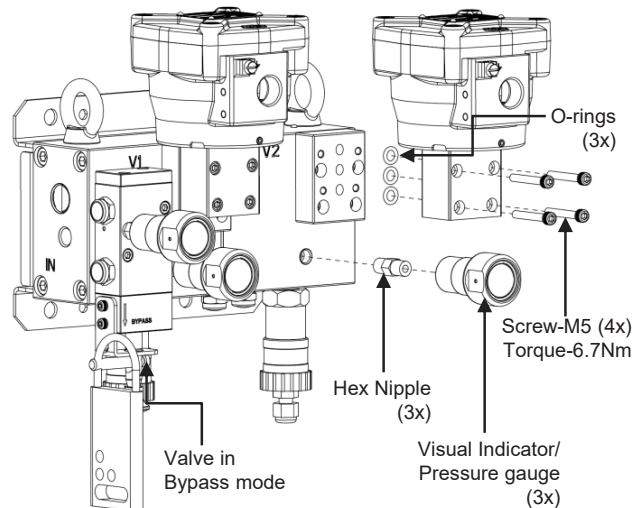

Fig: 5B

⚠ CAUTION: De-energizing two valves will initiate a shutdown.

Maintenance

The Pneumatic ARCS requires no routine maintenance except periodic inspections for loose wires and fittings. The solenoid enclosure should be opened occasionally and the components checked to make sure they are tight, clean, and dry. The Breather/Vent valve shall be inspected for obstruction and that it is free of debris during routine maintenance cycles and during manual proof testing.

Manual Bypass valve operation (Fig: 5B) (for maintenance only)

1. Remove the lockout and lock pin from the bypass valve.
2. Pull the knob downwards and put back the lockpin.
3. Put lockout and make it secured.
4. The system pressure is now bypassed directly from “inlet” to “outlet” so that the process valve position is maintained.
5. Verify the visual indicator/pressure gauge of bypass, it shows pressure availability.

⚠ WARNING: Secure the bypass valve operation until maintenance has been completed.

⚠ WARNING: Explosion Hazard. Do not remove or replace any component while circuit is live unless area is known to be non-hazardous.

6. Turn off power to the ARCS; disconnect appropriate wires from terminal block.
7. Remove device (coil or solenoid valve and install the new device.
8. Re-connect wires to appropriate terminal, Turn on power to the ARCS. Verify that each device has power and is in the correct state.
9. Remove the lockout and lockpin; push the knob to upwards.
10. Put the lockpin, lockout and make it secured. Now system is in “normal” mode.

⚠ CAUTION: While placing valve on the manifold ensure that all O-rings(3x) are placed on the valve correctly.

⚠ CAUTION: While doing valve maintenance, Do not try to operate corresponding bypass or isolation valve. Which will make pressure drop and lead to fail safe condition of actuator.

2oo2 with individual isolation and with diagnostic

The manually operated maintenance isolation valves(2x) is used to isolate and depressurize the each solenoid valve separately. This function allows to do maintenance of solenoid valve without disturbing the outlet air supply. We can monitor each solenoid valve healthiness at any time. Fig-6 shows circuit diagram.

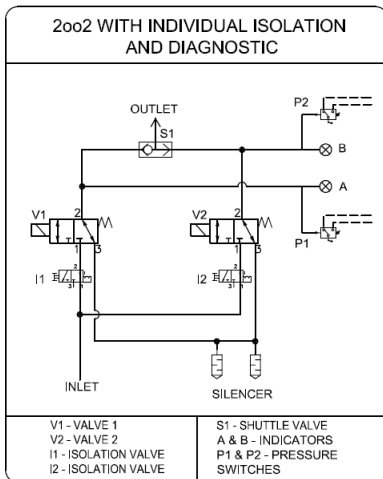

Fig: 6

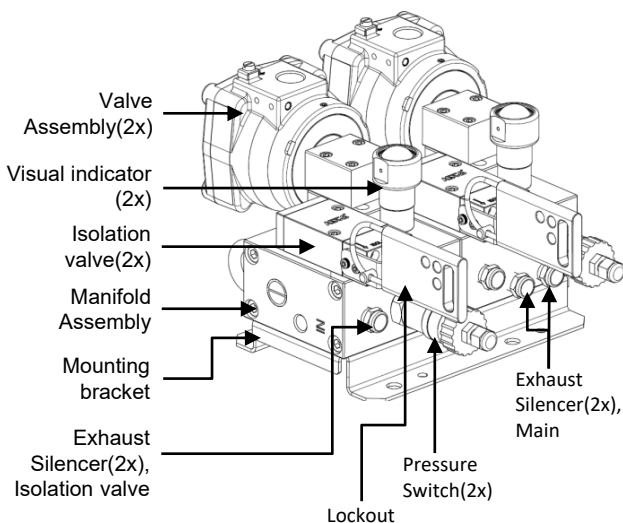

Fig: 6A

⚠ CAUTION: De-energizing two valves or doing isolation of two isolation valves will initiate a shutdown.

Maintenance

The Pneumatic ARCS requires no routine maintenance except periodic inspections for loose wires and fittings. The solenoid enclosure should be opened occasionally and the components checked to make sure they are tight, clean, and dry. The Breather/Vent valve shall be inspected for obstruction and that it is free of debris during routine maintenance cycles and during manual proof testing.

Isolation valve operation (for maintenance only)

1. Remove the lockout and lock pin from the isolation valve(I2).
2. Pull the knob downwards and put back the lockpin.
3. Put lockout and make it secured.

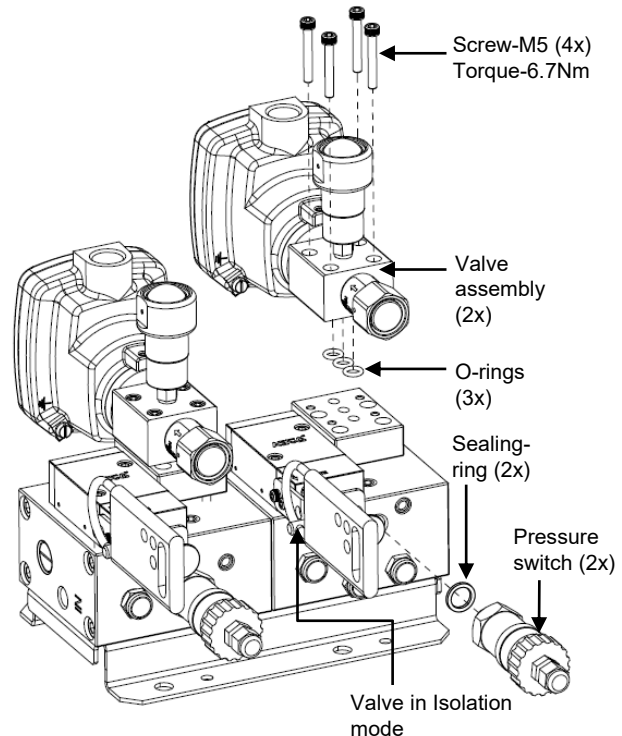

Fig: 6B

Fig. 6B shows Manual Operator/Manual reset valve Construction

4. The valve V2 pressure is now vented and valve is isolated from “inlet”. But Valve V1 is supply the air to “outlet” so that the process valve position is maintained.
5. Verify the visual indicator/pressure gauge of valve V2, it shows Red. Valve V1 visual indicator/pressure gauge shows Green.

⚠ WARNING: Secure the isolation valve operation until maintenance has been completed.

⚠ WARNING: Explosion Hazard. Do not remove or replace any component while circuit is live unless area is known to be non-hazardous.

6. Turn off power to the ARCS valve V2; disconnect appropriate wires from terminal block.
7. Remove device (coil, solenoid valve, Visual indicator, Pressure switch) and install the new device.
8. Re-connect wires to appropriate terminal, Turn on power to the ARCS valve V2. Verify the device has power and is in the correct state.
9. Remove the lockout and lockpin; push the knob to upwards.
10. Put the lockpin, lockout and make it secured. Now system is in “normal” mode.
11. Do the above same process for valve V1 maintenance.

⚠ CAUTION: While placing valve on the manifold

ensure that all O-rings(3x) are placed on the valve correctly.

⚠ CAUTION: While doing valve maintenance, Do not try to operate corresponding bypass or isolation valve. Which will make pressure drop and lead to fail safe condition of actuator.

2003 REDUNDANT VALVE SYSTEM

2003 is for safe exhausting and increased availability. It is enough to open process valve (availability) or close (Safety) with two of the three channels.

2003 without online maintenance and diagnostic

2003 redundant valve system has four solenoid valves which are connected in Parallel and series (Normally closed valve). Any one channel gets fail/de-energized system does not go to vent position. V1 is one channel, V2 & V3 are one channel, V4 is one channel. Fig-7 & 7A shows circuit diagram and logic table.

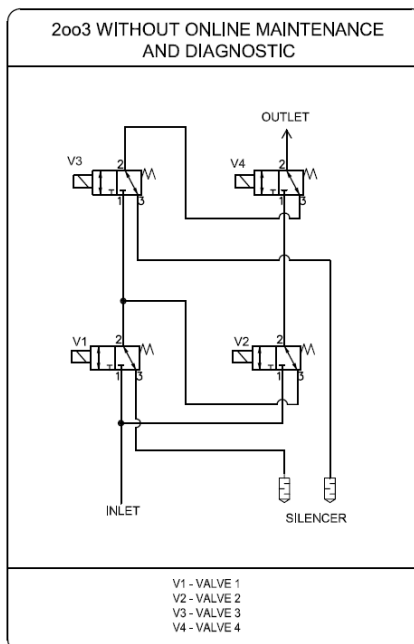

CH 1	CH 2		CH 3	OUTLET
V1	V2	V3	V4	
1	0	0	0	0
1	1	0	0	0
1	1	1	0	1
1	1	1	1	1
0	1	0	0	0
0	1	1	0	0
0	1	1	1	1
0	1	0	1	1
0	0	1	0	0
0	0	1	1	0
1	0	1	1	1
1	0	1	0	1
0	0	0	1	0
1	0	0	1	1
1	1	0	1	1
0	0	0	0	0

CH 1 - CHANNEL 1
 CH 2 - CHANNEL 2
 CH 3 - CHANNEL 3
 0 - VALVE DE-ENERGIZED
 1 - VALVE ENERGIZED

Fig: 7A

Fig: 7

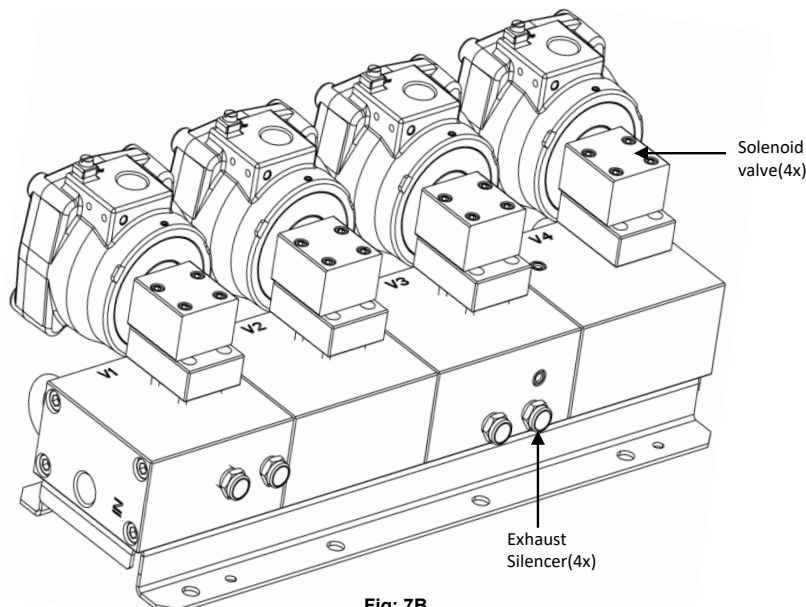

Fig: 7B

2003 without online maintenance and with diagnostic

In this logic four valves and two shuttle valves are connected. It has visual indicator and pressure switch options. Any one channel gets fail/de-energized system does not go to vent position. V1 & V4 are one channel, V2 is one channel, V3 is one channel. Fig-8A shows circuit diagram and logic table.

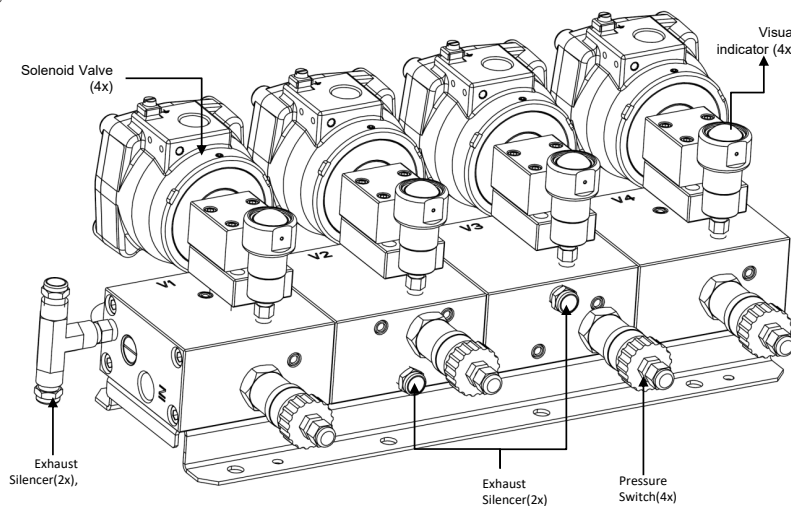
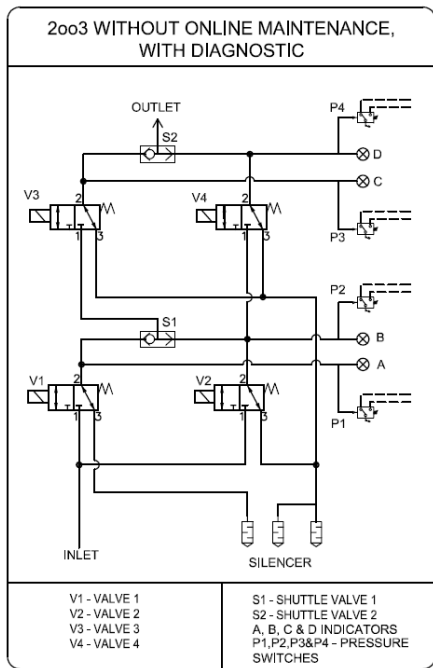

Fig: 8

⚠ CAUTION: De-energizing two channels will initiate a shutdown.



0 – Valve De-energized
1 – Valve energized

Fig: 8A

Channel-1		Channel-2	Channel-3	Visual Indicator A/ Pressure Switch P1	Visual Indicator D/ Pressure Switch P4	Visual Indicator B/ Pressure Switch P2	Visual Indicator C/ Pressure Switch P3	Outlet
V1	V4	V2	V3					
1	0	0	0	Green (Close)	Red (Open)	Red (Open)	Red (Open)	0
1	0	1	0	Green (Close)	Red (Open)	Green (Close)	Red (Open)	0
1	0	1	1	Green (Close)	Red (Open)	Green (Close)	Green (Close)	1
1	1	1	1	Green (Close)	Green (Close)	Green (Close)	Green (Close)	1
0	0	1	0	Red (Open)	Red (Open)	Green (Close)	Red (Open)	0
0	0	1	1	Red (Open)	Red (Open)	Green (Close)	Green (Close)	1
0	1	1	1	Red (Open)	Green (Close)	Green (Close)	Green (Close)	1
0	1	1	0	Red (Open)	Green (Close)	Green (Close)	Red (Open)	1
0	0	0	1	Red (Open)	Red (Open)	Red (Open)	Red*	0
0	1	0	1	Red (Open)	Red* (Open)	Red (Open)	Red*	0
1	1	0	1	Green (Close)	Red* (Open)	Red (Open)	Green (Close)	1
1	0	0	1	Green (Close)	Red (Open)	Red (Open)	Green (Close)	1
0	1	0	0	Red (Open)	Red* (Open)	Red (Open)	Red (Open)	0
1	1	0	0	Green (Close)	Red* (Open)	Red (Open)	Red (Open)	0
1	1	1	0	Green (Close)	Green (Close)	Green (Close)	Red (Open)	1
0	0	0	0	Red (Open)	Red (Open)	Red (Open)	Red (Open)	0

* Indicators show Red which is "False" state, due to unavailability of Pneumatic air since the valves are connected in series (Refer Circuit).

2003 with Individual isolation, with diagnostic

In this logic four valves and two shuttle valves are connected. The manually operated 3/2 way maintenance isolation valves(4x) are used to isolate and depressurize the each solenoid valve separately. This function allows to do maintenance of solenoid valve without disturbing the outlet air supply. We can monitor each solenoid valve healthiness at any time without disturbing process valve. It has visual indicator and pressure switch options. Fig-9 shows circuit diagram. Logic table refer Fig: 8A.

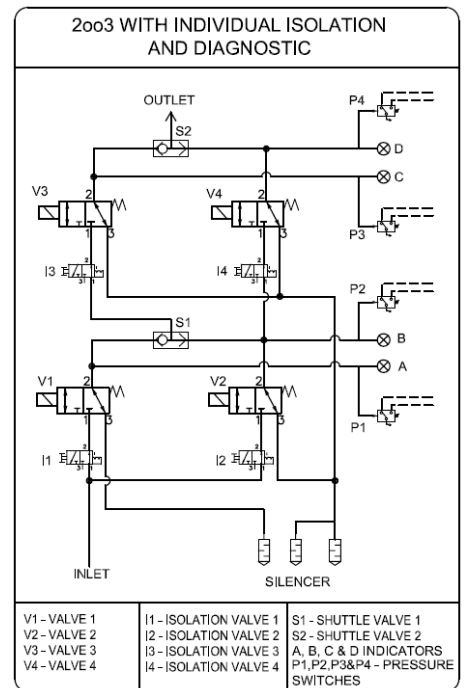

Fig: 9

CAUTION: De-energizing any two Channels will initiate a shutdown.

Maintenance

The Pneumatic ARCS requires no routine maintenance except periodic inspections for loose wires and fittings. The solenoid enclosure should be opened occasionally and the components checked to make sure they are tight, clean, and dry. The Breather/Vent valve shall be inspected for obstruction and that it is free of debris during routine maintenance cycles and during manual proof testing.

Isolation valve operation (for maintenance only)

1. Remove the lockout and lock pin from the isolation valve(I1).
2. Pull the knob downwards and put back the lockpin.
3. Put lockout and make it secured.
4. The valve V1 pressure is now vented and valve is isolated from “inlet”. But Channel 2 & 3 will supply the air to “outlet” so that the process valve position is maintained.
5. Verify the visual indicator/pressure gauge of valve V1, it shows Red. Remaining valves visual indicator/pressure gauge shows Green.

WARNING: Secure the isolation valve operation until maintenance has been completed.

WARNING: Explosion Hazard. Do not remove or replace any component while circuit is live unless area is known to be non-hazardous.

6. Turn off power to the ARCS valve V1; disconnect appropriate wires from terminal block.
7. Remove device (coil, solenoid valve, Visual indicator, Pressure switch) and install the new device.
8. Re-connect wires to appropriate terminal, Turn on power to the ARCS valve V1. Verify the device has power and is in the correct state.
9. Remove the lockout and lockpin; push the knob to upwards.

	<h1 style="margin: 0;">Installation & Maintenance Instructions</h1> <p style="margin: 0;">Advanced Redundant Control System (ARCS) Direct Acting Platform</p>	<p style="margin: 0;">SERIES</p> <p style="margin: 0;">141</p>
---	---	--

10. Put the lockpin and lockout and make it secured. Now system is in “normal” mode.
11. Do the above same process for other valve maintenance.

⚠ CAUTION: While placing valve on the manifold ensure that all O-rings(3x) are placed on the valve correctly.

⚠ CAUTION: While doing valve maintenance, Do not try to operate corresponding bypass or isolation valve. Which will make pressure drop and lead to fail safe condition of actuator.

Spare Parts

⚠ WARNING: Replacement parts are only to be obtained from ASCO or an authorized distributor or the certifications may be invalidated or there may be a risk of explosion.

Limited Warranty

WARRANTIES: The manufacturer warrants its products and equipment to be free from defects in material and workmanship for a period of one year from the date of shipment from its factory. The Manufacturer is not responsible for damage to its products through normal wear and tear, improper installation, maintenance, use, repairs or adjustment, or attempts to operate it above its rated capacity or voltage, intentional or otherwise, or for unauthorized repairs. To the extent the Manufacturer has relied upon specifications, information, representation of operating conditions or other are supplied by Buyer or its agents to Seller in the selection or design of the goods, and the operation conditions or other conditions differ from those represented by the Buyer and relied upon by Manufacture, and warranties or other provisions contained herein which are affected by such conditions shall be null and void.

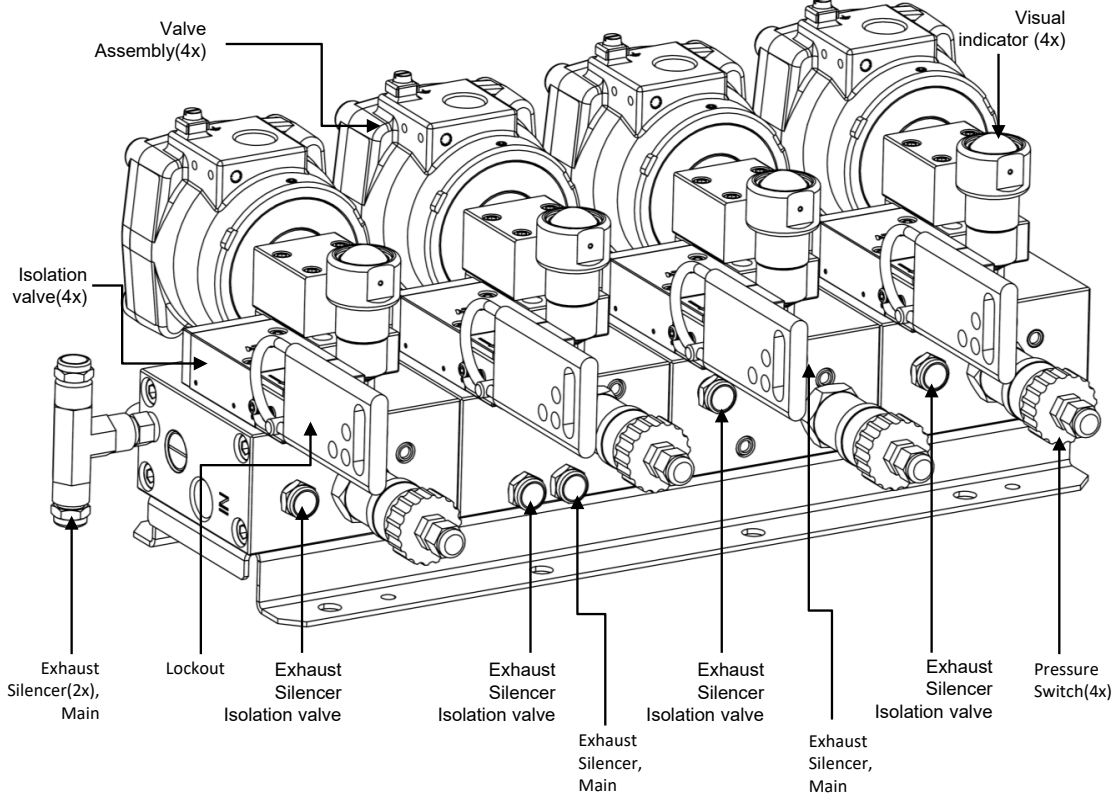

Fig: 9A

NO OTHER REPRESENTATION, GUARANTEES OR WARRANTIES, EXPRESSED OR IMPLIED, ARE MADE BY THE MANUFACTURE AND THE FOREGOING WARRANTY IS IN LIEU OF ALL OTHER REPRESENTATIONS AND WARRANTIES, EXPRESSED OR IMPLIED, WHICH ARE HEREBY EXPRESSLY DISCLAIMED AND WAIVED BY BUYER, INCLUDING ANY WARRANTY OF MERCHANTABILITY OR OF FITNESS FOR PARTICULAR PURPOSE, WHETHER OR NOT THE PURPOSE OR USE HAS BEEN DISCLOSED TO SELLER IN SPECIFICATION, DRAWING OR OTHERWISE, AND WHETHER OR NOT THE PRODUCT IS SPECIFICALLY DESIGNED AND/OR MANUFACTURED FOR BUYERS USE OF PURPOSE.

Disclaimer

Because of the variety of uses for the ASCO Advanced Redundant Control System (ARCS), the user and those responsible for applying this equipment must satisfy themselves as to the acceptability of the ARCS for each application.

The illustrations in this manual are solely intended to illustrate the text of this manual. Because of the many variables and requirements associated with this particular installation, ASCO cannot assume responsibility or liability for actual use based upon the illustrative uses and applications.

In no event will ASCO be responsible or liable for indirect or consequential damages resulting from the use or application of this equipment. ASCO disclaims any implied warranties of merchantability or fitness for a particular purpose.

ASCO DISCLAIMS ANY IMPLIED WARRANTY OR FITNESS FOR A PARTICULAR PURPOSE.

No patent or copyright liability is assumed by ASCO with respect to use of information, circuits, equipment or software described in this text. Reproduction of the content of this manual, in whole or in part, without written permission from ASCO is prohibited.