

Quick Reference Guide

P/N 3006075, Rev. D

May 2003

Micro Motion® CMF400 Sensor Installation Instructions

For online technical support, use the EXPERT₂™ system at www.expert2.com. To speak to a customer service representative, call the support center nearest you:

- In the U.S.A., phone 1-800-522-MASS (1-800-522-6277)
- In Canada and Latin America, phone (303) 530-8400
- In Asia, phone (65) 6770-8155
- In the U.K., phone 0800 - 966 180 (toll-free)
- Outside the U.K., phone +31 (0) 318 495 670



BEFORE YOU BEGIN

This quick reference guide explains basic installation guidelines for the Micro Motion® ELITE® CMF400 sensor. For more information, refer to the instruction manual that was shipped with the sensor.

European installations

This Micro Motion product complies with all applicable European directives when properly installed in accordance with the instructions in this quick reference guide. Refer to the EC declaration of conformity for directives that apply to this product.

The EC declaration of conformity, with all applicable European directives, and the complete *ATEX Installation Drawings and Instructions* are available on the internet at www.micromotion.com/atex or through your local Micro Motion support center.

INTRODUCTION

The sensor makes up one part of a Coriolis flowmeter. The other part is a transmitter.

Installation options

The CMF400 sensor is available with:

- An integral core processor for connecting to a 4-wire remotely mounted transmitter or to a user-supplied remote host (see Figure 1 or Figure 2).
- A 9-wire junction box for connecting to a remotely mounted transmitter, or to a remotely mounted core processor (see Figure 3 or Figure 4).

Figure 1. CMF400 sensor with integral booster amplifier and core processor

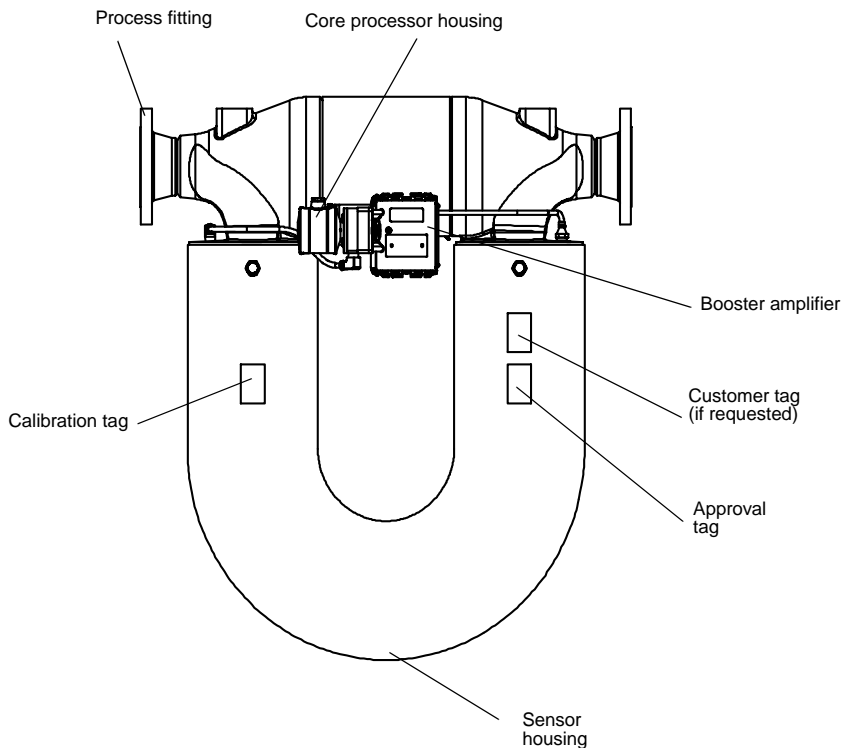

Figure 2. CMF400 sensor with remote booster amplifier and core processor

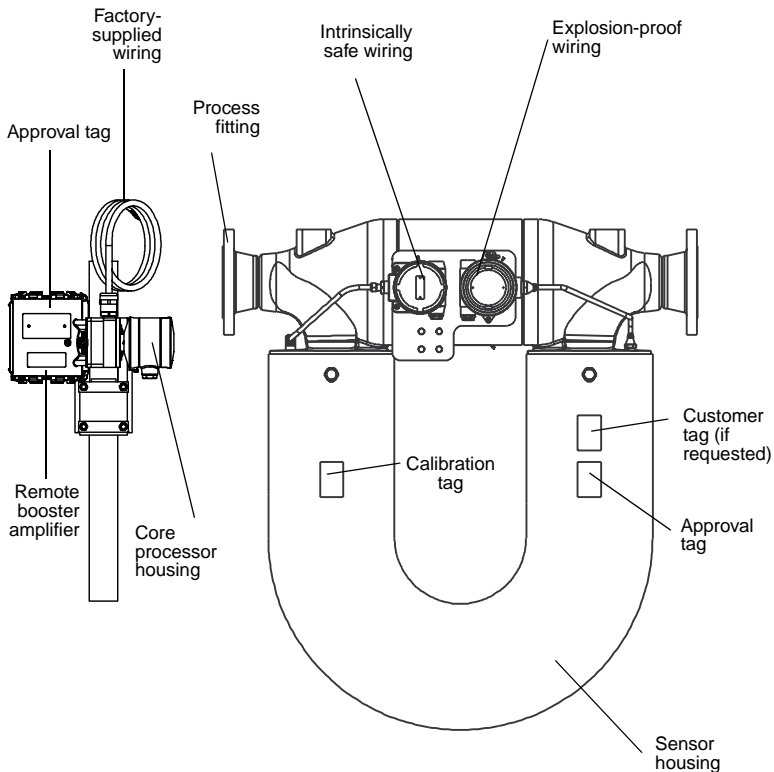

Figure 3. CMF400 sensor with integral booster amplifier and junction box

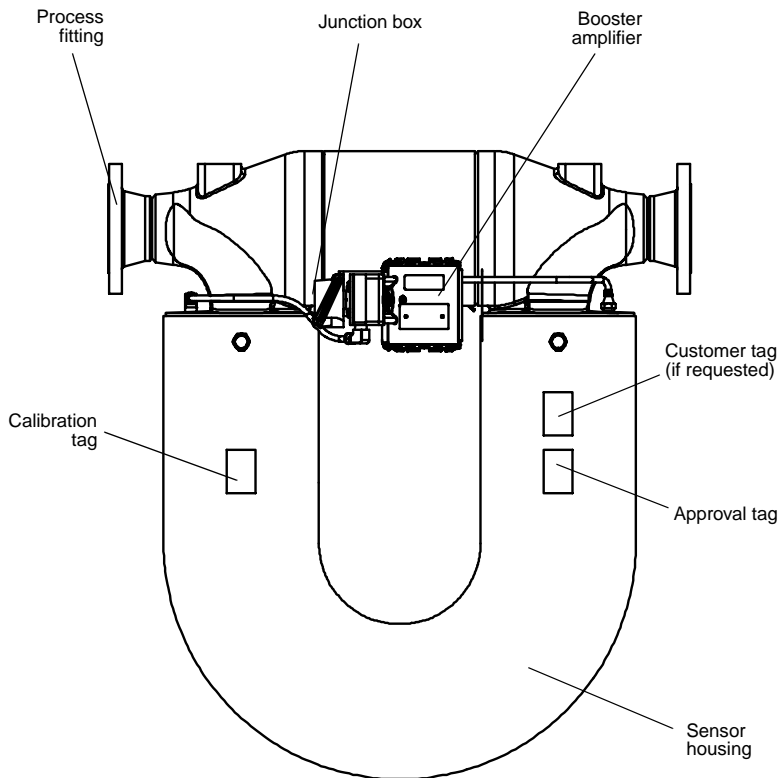
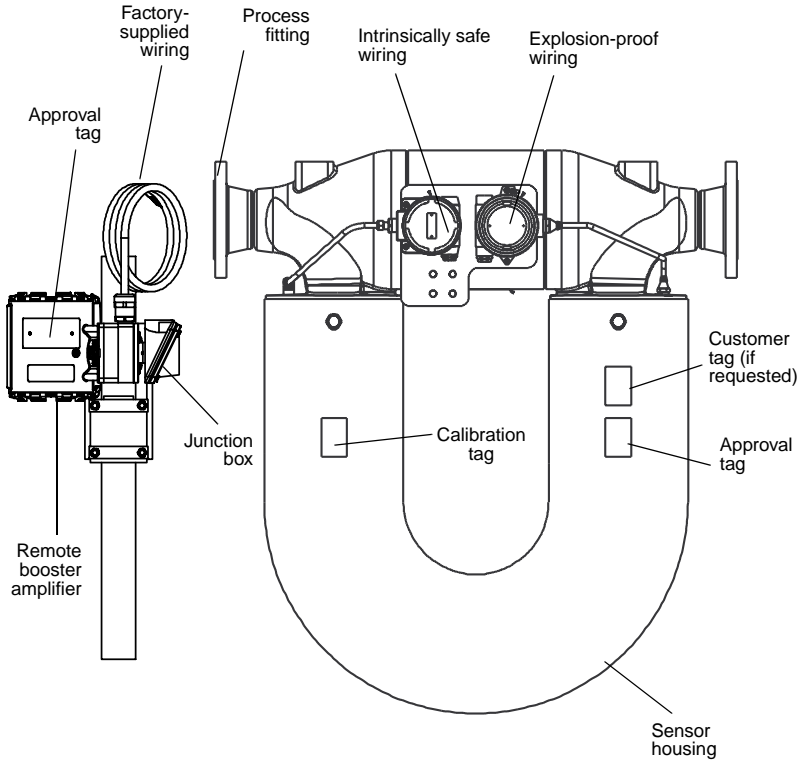

Figure 4. CMF400 sensor with remote booster amplifier and junction box



STEP 1. Determining a location

Choose a location for the sensor based on the requirements described in this section.

General guidelines

The following conditions must be met:

- Before operation, you must be able to stop flow through the sensor. (During the zeroing procedure, flow must be stopped completely, and the sensor must be full of process fluid.)
- During operation, the sensor must remain full of process fluid.
- The sensor must be installed in an area that is compatible with the classification specified on the sensor approvals tag (see Figures 1-4).

Hazardous area installations

Make sure the hazardous area specified on the sensor approvals tag is suitable for the environment in which the sensor is installed. See Figures 1-4. For installation in an area that requires intrinsic safety, refer to Micro Motion UL, CSA, or ATEX documentation, shipped with the sensor or available from the Micro Motion web site.

For a complete list of hazardous area classifications for Micro Motion sensors, refer to the Expert₂ system at www.expert2.com.

Environmental limits

Install the sensor in a location that falls within the following limits:

- Process fluid temperature limits between -40 to $+140$ °F (-40 to $+60$ °C) for the integrally mounted booster amplifier with either the core processor or junction box.
- Process fluid temperature limits between -400 to $+400$ °F (-240 to $+200$ °C) for the remotely mounted booster amplifier with either the core processor or junction box.
- Ambient temperature limits between -40 to $+140$ °F (-40 to $+60$ °C) with core processor or junction box.

For ATEX approvals, process fluid temperature can be further restricted by ambient temperatures. For guidelines, go to www.micromotion.com/atex.

Maximum wiring distances

Use these guidelines for calculating maximum wiring distances. Maximum distance between sensor and transmitter depends on cable type. See Table 1.

Table 1. Maximum cable lengths

Cable type	Wire gauge	Maximum length
Micro Motion 9-wire to an MVD transmitter or core processor	Not applicable	60 feet (20 meters)
Micro Motion 9-wire to all other transmitters	Not applicable	1000 feet (300 meters)
Micro Motion 4-wire	Not applicable	1000 feet (300 meters)
User-supplied 4-wire		
• Power wires (VDC)	22 AWG (0,35 mm ²)	300 feet (90 meters)
	20 AWG (0,5 mm ²)	500 feet (150 meters)
	18 AWG (0,8 mm ²)	1000 feet (300 meters)
• Signal wires (RS-485)	22 AWG (0,35 mm ²) or larger	1000 feet (300 meters)

The sensor is shipped with 10 feet (3 meters) of cable for connecting to the remote booster amplifier. For longer cable lengths, up to 60 ft (20 m), contact Micro Motion.

STEP 2. Orienting the sensor

The sensor will function properly in any orientation if the sensor tubes remain filled with process fluid. Micro Motion recommends orienting the CMF400 sensor as shown in Figure 5.

Flow direction arrow

The sensor has a flow direction arrow (see Figures 1-4) to help you configure the transmitter for flow direction. If possible, install the sensor so that the flow direction arrow matches actual process flow.

Figure 5. Preferred orientations

Fluid being measured	Preferred orientation
Liquids	Tubes down Horizontal pipeline
Gases	Tubes up Horizontal pipeline
Slurries	Flag mount Vertical pipeline Self-draining

STEP 3. Mounting the sensor

Use your common practices to minimize torque and bending load on process connections. Figure 6 illustrates how to mount the sensor. If possible, install wiring with the conduit opening pointed downward to reduce the risk of condensation or excessive moisture.

⚠ CAUTION

Using the sensor to support piping can damage the meter or cause measurement error.

Do not use flowmeter to support pipe.

Figure 6. Mounting the sensor

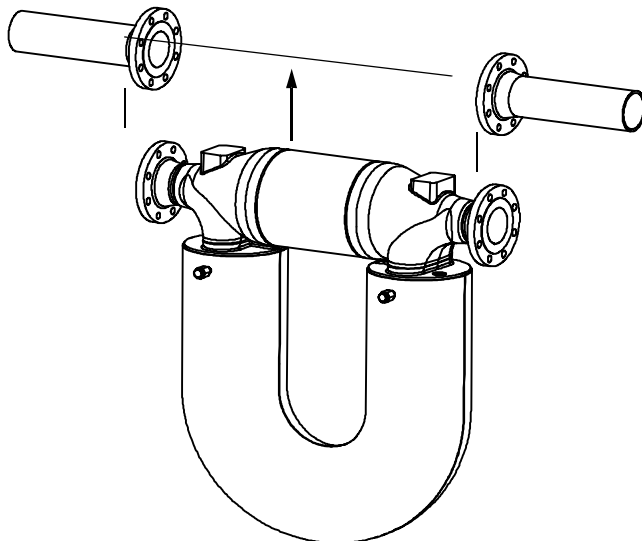

⚠ WARNING

Explosion hazard

The CMF400 has drain plugs, which look similar to purge fittings. The drain plugs must remain sealed at all times. Do not remove or damage CMF400 drain plugs.

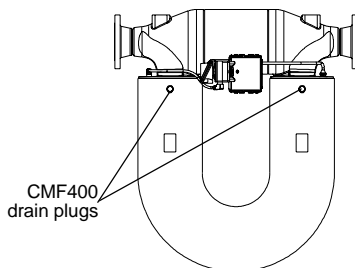

STEP 4. Wiring to the booster amplifier

Remote booster amplifier wiring

The remotely mounted booster amplifier is mounted up to 10 feet (3 meters) from the sensor. See Figure 7.

- Provide 85-250 VAC of power.
- Figures 8 and 9 illustrate how to connect power-supply wiring.

Figure 7. Wiring to remote booster amplifier

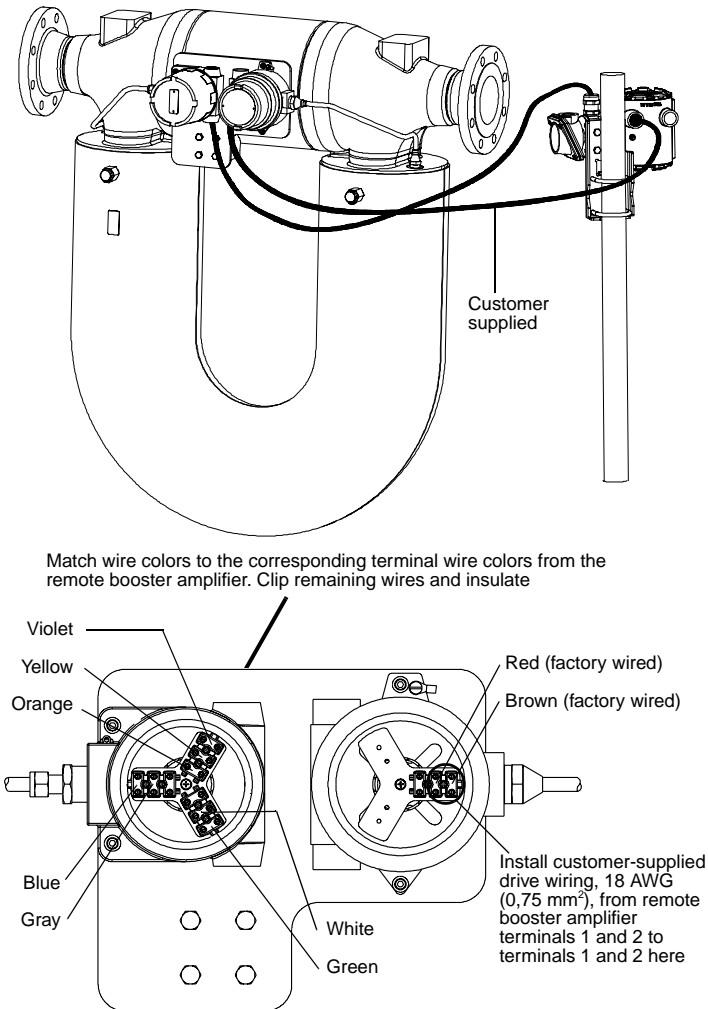

Figure 8. Power-supply wiring on integrally mounted booster amplifier

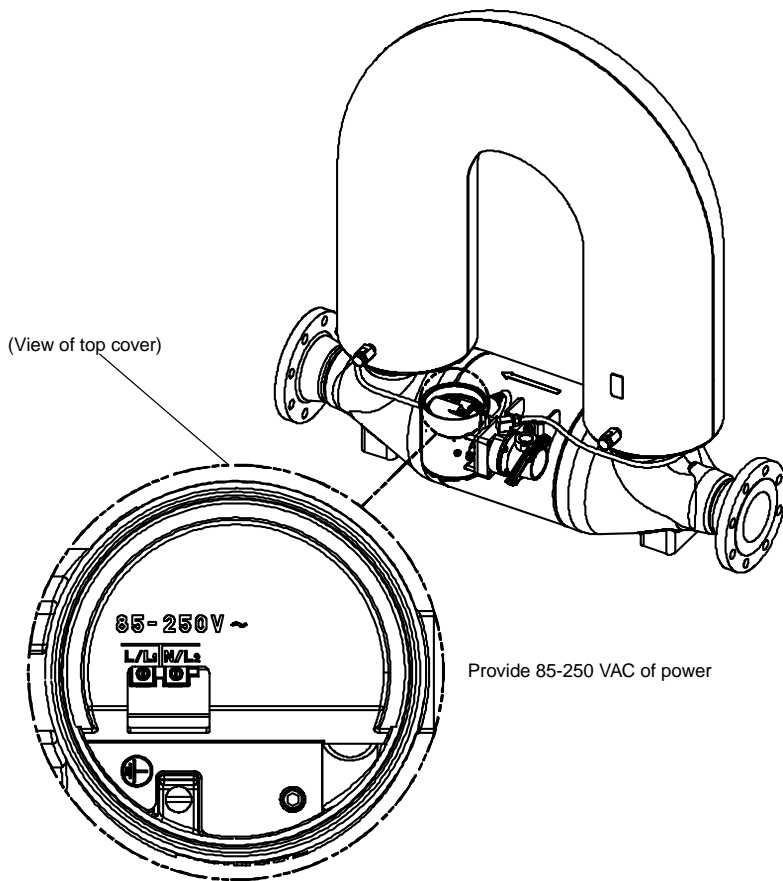
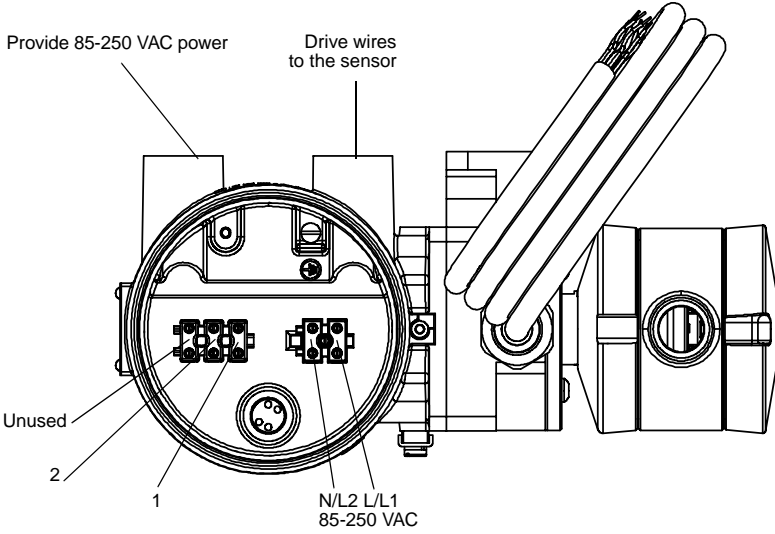

Figure 9. Power-supply wiring on remote booster amplifier

Remote booster amplifier with core processor

Remove screw and terminal cover before installing wiring. Re-install cover before operating



Remote booster amplifier with junction box

Remove screw and terminal cover before installing wiring. Re-install cover before operating

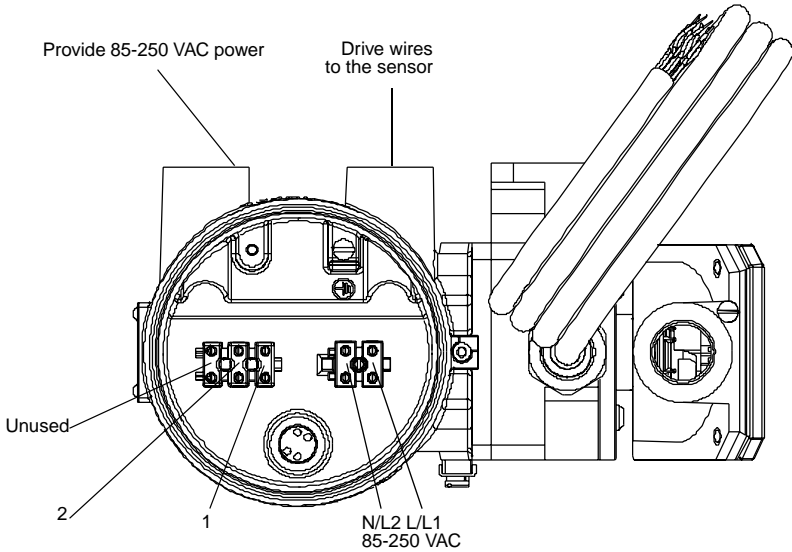

STEP 5. Wiring the sensor to the transmitter

WARNING

Failure to comply with requirements for intrinsic safety in a hazardous area could result in an explosion.

- For installation in an area that requires intrinsic safety, refer to Micro Motion UL, CSA, or ATEX documentation, shipped with the sensor or available from the Micro Motion web site.
- For hazardous area installations in Europe, refer to standard EN 60079-14 if national standards do not apply.

CAUTION

Failure to seal the sensor and transmitter housings could cause a short circuit, which would result in measurement error or flowmeter failure.

- Ensure integrity of gaskets and O-rings.
- Grease all O-rings before sealing.
- Install drip legs in cable or conduit.
- Seal all conduit openings.

Installation options

The sensor has one of the following configurations:

- A core processor to a 4-wire remote transmitter or remote host (requires a 4-wire cable); see *Core processor to a 4-wire remote transmitter or remote host*, page 14.
- 9-wire junction box to a remote transmitter (requires a 9-wire cable); see *9-wire junction box cable wiring*, page 19.

Core processor to a 4-wire remote transmitter or remote host

To connect wiring at the core processor:

1. Use one of the following methods to shield the wiring from the core processor to the remote transmitter:
 - If you are installing unshielded wiring in continuous metallic conduit that provides 360° termination shielding for the enclosed wiring, go to Step 6, page 17.
 - If you are installing user-supplied cable gland with shielded cable or armored cable, terminate the shields in the cable gland. Terminate both the armored braid and the shield drain wires in the cable gland.
 - If you are installing a Micro Motion-supplied cable gland at the core processor housing:
 - Prepare the cable and apply shielded heat shrink as described below. The shielded heat shrink provides a shield termination suitable for use in the gland when using cable whose shield consists of foil and not a braid. Proceed to Step 2.
 - With armored cable, where the shield consists of braid, prepare the cable as described below, but do not apply heat shrink. Proceed to Step 2.
2. Remove the cover from the core processor.
3. Slide the gland nut and the clamping insert over the cable.

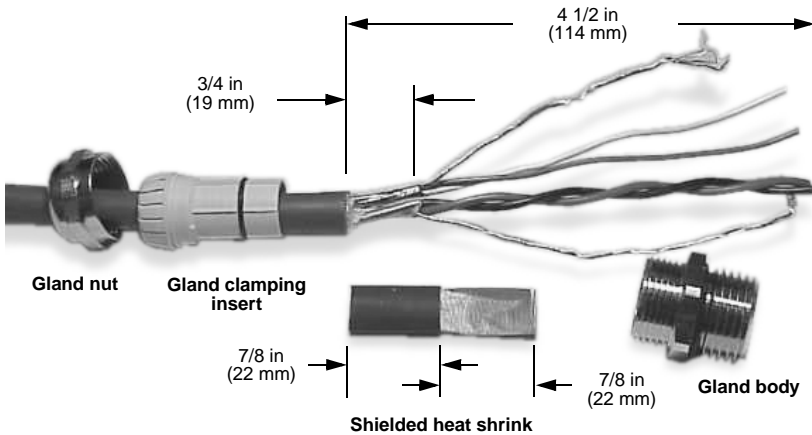

4. For connection at the core processor housing, prepare shielded cable as follows (for armored cable, omit steps d, e, f, and g):
 - a. Strip 4 1/2 inches (114 mm) of cable jacket.
 - b. Remove the clear wrap that is inside the cable jacket, and remove the filler material between the wires.
 - c. Remove the foil shield that is around the insulated wires, leaving 3/4 inch (19 mm) of foil or braid and drain wires exposed, and separate the wires.
 - d. Wrap the shield drain wire(s) around the exposed foil twice. Cut off the excess wire.

Shield drain wire(s) wrapped twice around exposed shield foil



- e. Place the EMI-shielded heat shrink over the exposed shield drain wire(s). The tubing should completely cover the drain wires.

- f. Without burning the cable, apply heat (250 °F or 120 °C) to shrink the tubing.

Shielded heat shrink completely covers exposed drain wires



- g. Position gland clamping insert so the interior end is flush with the heat shrink.
- h. Fold the cloth shield or braid and drain wires over the clamping insert and approximately 1/8 inch (3 mm) past the O-ring.

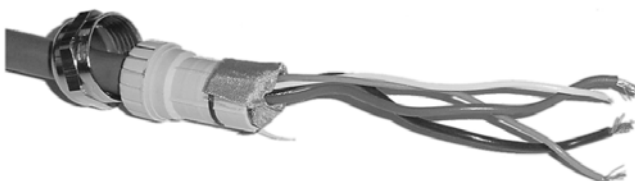

- i. Install the gland body into the core processor housing conduit opening.



5. Insert the wires through the gland body and assemble the gland by tightening the gland nut.
6. Identify the wires in the 4-wire cable. The 4-wire cable supplied by Micro Motion consists of one pair of 18 AWG (0,75 mm²) wires (red and black), which should be used for the VDC connection, and one pair of 22 AWG (0,35 mm²) wire (green and white), which should be used for the RS-485 connection. Connect the four wires to the numbered slots on the core processor, matching corresponding numbered terminals on the transmitter.

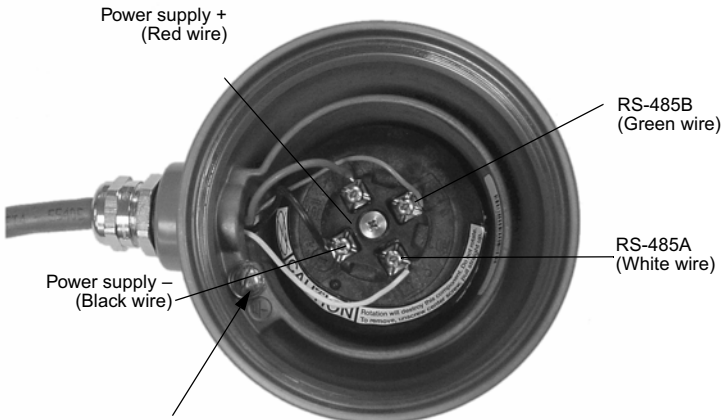

Core processor housing internal ground screw

- For connections to earth ground when sensor cannot be grounded via piping and local codes require ground connections to be made internally
- Do not connect shield drain wires to this terminal

7. Reattach the core processor housing.

⚠ WARNING

Twisting the core processor will damage the sensor.

Do not twist the core processor.

8. Shield and shield drain wire(s) should not be grounded at the transmitter.
 - For wiring at the transmitter, see the transmitter Quick Reference Guide (QRG).
 - If you are connecting to an MVDSolo with MVD Direct Connect™ I.S. barrier supplied by Micro Motion, the barrier supplies power to the core processor. Refer to the barrier documentation to identify the terminals at the barrier.
 - If you are connecting to an MVDSolo without I.S. barrier:
 - Connect the VDC wires from the core processor (see Figure 10) to an independent power supply. This power supply must connect only to the core processor. A recommended power supply is the SDN series of 24-VDC power supplies manufactured by Sola/Hevi-Duty.
 - Do not ground either connection of the power supply.
 - Connect the RS-485 wires from the core processor (see Figure 10) to the RS-485 terminals at the remote host. Refer to the vendor documentation to identify the terminals.

Figure 10. Core processor terminals

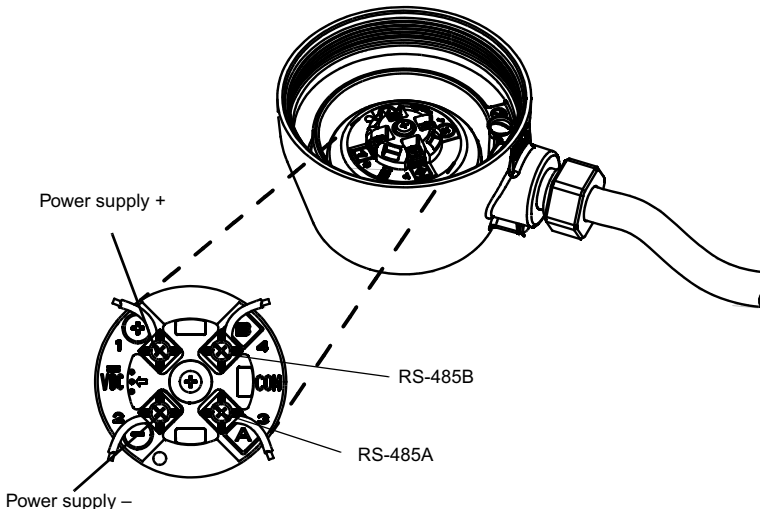

9-wire junction box cable wiring

Follow the steps below to connect the 9-wire cable between the sensor and the transmitter.

1. Prepare and install the cable according to the instructions in Micro Motion's *9-Wire Flowmeter Cable Preparation and Installation Guide*.
2. Insert the stripped ends of the individual wires into the terminal blocks. No bare wires should remain exposed.
3. Match the wires color for color. For wiring at the transmitter, refer to the transmitter QRG.
4. Tighten the screws to hold the wires in place.
5. Ensure integrity of gaskets, then tightly close and seal the junction box cover and all housing covers on the transmitter.

STEP 6. Grounding the sensor

CAUTION

Improper grounding could cause measurement error.

To reduce the risk of measurement error:

- Ground the flowmeter to earth, or follow ground network requirements for the facility.
- For installation in an area that requires intrinsic safety, refer to Micro Motion UL, CSA, or ATEX documentation, shipped with the sensor or available from the Micro Motion web site.
- For hazardous area installations in Europe, refer to standard EN 60079-14 if national standards do not apply.

The sensor can be grounded via the piping if the joints in the pipeline are ground-bonded. If the sensor is not grounded via the piping, connect a ground wire to the internal or external grounding screw, which is located on the core processor or junction box.

If national standards are not in effect, follow these guidelines:

- Use copper wire, 14 AWG (2,5 mm²) or larger wire size for grounding.
- Keep all ground leads as short as possible, less than 1 ohm impedance.
- Connect ground leads directly to earth, or follow plant standards.

Refer to the transmitter documentation for instructions on grounding the transmitter.

©2003, Micro Motion, Inc. All rights reserved. P/N 3006075, Rev. D



Visit us on the Internet at www.micromotion.com

Micro Motion Inc. USA
Worldwide Headquarters

7070 Winchester Circle
Boulder, Colorado 80301
T (303) 530-8400
(800) 522-6277
F (303) 530-8459

Micro Motion Europe

Emerson Process Management
Wiltonstraat 30
3905 KW Veenendaal
The Netherlands
T +31 (0) 318 495 670
F +31 (0) 318 495 689

Micro Motion Asia

Emerson Process Management
1 Pandan Crescent
Singapore 128461
Republic of Singapore
T (65) 6777-8211
F (65) 6770-8003

Micro Motion United Kingdom

Emerson Process Management Limited
Horsfield Way
Bredbury Industrial Estate
Stockport SK6 2SU U.K.
T 0800 966 180
F 0800 966 181

Micro Motion Japan

Emerson Process Management
Shinagawa NF Bldg. 5F
1-2-5, Higashi Shinagawa
Shinagawa-ku
Tokyo 140-0002 Japan
T (81) 3 5769-6803
F (81) 3 5769-6843

