

# Fisher™ 846 Electro-Pneumatic Transducer

## Contents

Introduction	
Scope of Manual	2
Description	2
Specifications	2
Educational Services	5
Installation	6
Hazardous Area Classifications and Special Instructions for Safe-Use and Installation in Hazardous Locations	7
Mounting	8
Pressure Connections	8
Supply Pressure	10
Output Pressure	14
Electrical Connections	14
Venting Ports	15
Signal Interruption	15
Calibration	16
Standard Performance:	
Full Range Input, Direct Action	18
Multirange Performance:	
Full Range Input, Direct Action	18
Standard Performance:	
Split Range Input, Direct Action	19
4 to 12 mA Input Signal	19
12 to 20 mA Input Signal	19
Standard Performance:	
Full Range Input, Reverse Action	20
Multirange Performance:	
Full Range Input, Reverse Action	20
Standard Performance:	
Split Range Input, Reverse Action	21
4 to 12 mA Input Signal	21
12 to 20 mA Input Signal	21
Transporting the Module Final Assembly	22
Principle of Operation	22
Electronic Circuit	22
Magnetic Actuator	23
Pilot Stage	23
Booster Stage	24
Troubleshooting	25
Diagnostic Features	25
Stroke Port	25

Figure 1. Fisher 846 Electro-Pneumatic Transducer



X0234

Remote Pressure Reading (RPR)	25
Using a Frequency Counter to read the RPR Signal	25
In-service Troubleshooting	26
Troubleshooting in the Shop	29
Maintenance	31
Module Final Assembly	32
Removing the Module Final Assembly	34
Replacing the Module Final Assembly	35
Electronic Circuit Board	36
Remote Pressure Reading (RPR) Jumper	36
Range Jumper	37
Action	37
Removing the Electronic Circuit Board	37
Replacing the Electronic Circuit Board	38
Pilot/Actuator Assembly	38
Action	38
Removing the Pilot/Actuator Assembly	39
Replacing the Pilot/Actuator Assembly	39
Module Subassembly	40
Terminal Compartment	40
Exhaust and Stroke Port Screens	41
Parts	42

# Introduction

## Scope of Manual

This instruction manual provides installation, operating, calibration, maintenance, and parts ordering information for Fisher 846 electro-pneumatic transducers. Refer to separate manuals for instructions covering equipment used with the transducers.



Do not install, operate or maintain an 846 electro-pneumatic transducer without being fully trained and qualified in valve, actuator, and accessory installation, operation, and maintenance. To avoid personal injury or property damage, it is important to carefully read, understand, and follow all of the contents of this manual, including all safety cautions and warnings. If you have any questions about these instructions, contact your [Emerson sales office](#) before proceeding.

## Description

The 846 electro-pneumatic transducer, shown in figure 1, accepts an electrical input signal and produces a proportional pneumatic output. Typically, 4 to 20 mA is converted to 0.2 to 1.0 bar (3 to 15 psi). Models are available in direct or reverse action and field-selectable for full or split range inputs. Refer to the Calibration section for more information on input/output combinations.

The most common application of the transducer is to receive an electrical signal from a controller and produce a pneumatic output for operating a control valve actuator or positioner. The 846 may also be used to produce a signal for a pneumatic receiving instrument.

The 846 is an electronic I/P transducer. It has a single electronic circuit board, as shown in figure 2. The circuit contains a solid-state pressure sensor that monitors output pressure and is part of an electronic feedback network. The self-correcting ability provided by the sensor/circuit combination allows the transducer to produce a very stable and responsive output signal.

All active mechanical and electrical components of the 846 are incorporated into a single, field-replaceable module called the module final assembly, shown in figure 2. The module final assembly contains the electronic circuit board, pilot/actuator assembly, and booster stage. The module final assembly is easily removed by unscrewing the module cover. Its design minimizes parts and reduces the time required for repair and troubleshooting.

The terminal compartment and module compartment are separated by a sealed compartment wall. This multi-compartment housing also protects the electronics from contaminants and moisture in the supply air.

## Specifications

### **⚠ WARNING**

**This product is intended for a specific range of pressures, temperatures, and other application specifications. Applying different pressure, temperature and other service conditions could result in a malfunction of the product, property damage or personal injury.**

Specifications for the 846 transducer are listed in table 1.

Table 1. Specifications

<p><b>Input Signal</b></p> <p><b>Standard Performance:</b> 4 to 20 mA DC, 4 to 12 mA DC, or 12 to 20 mA DC. Field adjustable split ranging.</p> <p><b>Multirange Performance:</b> 4 to 20 mA DC. Consult factory for split range input</p> <p><b>Equivalent Circuit</b></p> <p>See figure 3</p> <p><b>Output Signal<sup>(1)</sup></b></p> <p><b>Standard Performance:</b> <i>(Consult factory for split range output)</i> <b>Direct Action (Minimum span of 6 psi)</b> Typical outputs: 0.2 to 1.0 bar (3 to 15 psi). Rangeability between 0.1 and 1.2 bar (1 and 18 psi) <b>Reverse Action (Minimum span of 11 psi)</b> Typical outputs: 1.0 to 0.2 bar (15 to 3 psi) Rangeability between 1.2 and 0.1 bar (18 and 1 psi)</p> <p><b>Multirange Performance:</b> <b>Direct Action (Minimum span of 6 psi)</b> Typical outputs: 0.2 to 1.9 bar (3 to 27 psi), 0.4 to 2 bar (6 to 30 psi), and 0.3 to 1.7 bar (5 to 25 psi) Rangeability between 0.03 and 2.3 bar (0.5 and 33 psi) <b>Reverse Action (Minimum span of 11 psi)</b> Typical outputs: 1.9 to 0.2 bar (27 to 3 psi), 2 to 0.4 bar (30 to 6 psi), and 1.7 to 0.3 bar (25 to 5 psi) Rangeability between 2.3 and 0.03 bar (33 and 0.5 psi)</p> <p><b>Supply Pressure<sup>(2)</sup></b></p> <p><b>Standard Performance:</b> 1.2 to 1.6 bar (18 to 24 psi)</p> <p><b>Multirange Performance:</b> 0.2 bar (3 psi)<sup>(3)</sup> greater than the maximum calibrated output pressure</p> <p><b>Maximum:</b> 2.4 bar (35 psi)</p> <p><b>Supply Pressure Medium</b></p> <p>Clean, dry air</p> <p><b>Per ISA Standard 7.0.01</b> A maximum 40 micrometer particle size in the air system is acceptable. Further filtration down to 5 micrometer particle size is recommended. Lubricant content is not to exceed 1 ppm weight (w/w) or volume (v/v) basis. Condensation in the air supply should be minimized</p>	<p><i>Pressure dew point:</i> At least 10°C less than the lowest ambient temperature expected</p> <p><b>Per ISO 8573-1</b> <i>Maximum particle density size:</i> Class 7 <i>Oil content:</i> Class 3 <i>Pressure dew point:</i> Class 3</p> <p><b>Output Air Capacity<sup>(4)</sup></b></p> <p><b>Standard:</b> 6.4 m<sup>3</sup>/hr (240 scfh) at 1.4 bar (20 psi) supply pressure</p> <p><b>Multirange:</b> 9.7 m<sup>3</sup>/hr (360 scfh) at 2.5 bar (35 psig) supply pressure</p> <p><b>Maximum Steady-State Air Consumption<sup>(4)</sup></b></p> <p>0.3 m<sup>3</sup>/hr (12 scfh) at 1.4 bar (20 psi) supply pressure</p> <p><b>Temperature Limits<sup>(2)</sup></b></p> <p><b>Operating:</b> -40 to 85°C (-40 to 185°F)</p> <p><b>Storage:</b> -40 to 93°C (-40 to 200°F)</p> <p><b>Humidity Limits</b></p> <p>0 to 100% condensing relative humidity</p> <p><b>Performance<sup>(5)</sup></b></p> <p><b>Note: The performance of all 846 I/Ps is verified using computer automated manufacturing systems to ensure that every unit shipped meets its performance specifications</b></p> <p><b>Accuracy:</b> ± 0.30% of output span</p> <p><b>Linearity, Hysteresis, and Repeatability:</b> ± 0.3% of span.</p> <p><b>Temperature Effect (total effect including zero and span):</b> ± 0.07%/°C (0.045%/°F) of span</p> <p><b>Vibration Effect:</b> ± 0.3% of span per g during the following conditions: 5 to 15 Hz at 4 mm constant displacement 15 to 150 Hz at 2 g. 150 to 2000 Hz at 1 g. per SAMA Standard PMC 31.1, Sec. 5.3, Condition 3, Steady State</p> <p><b>Shock Effect:</b> ± 0.5% of span, when tested per SAMA Standard PMC 31.1, Sec. 5.4.</p> <p><b>Supply Pressure Effect:</b> Negligible</p>
--------------------------------------------------------------------------------------------------------------------------------------------------------------------------------------------------------------------------------------------------------------------------------------------------------------------------------------------------------------------------------------------------------------------------------------------------------------------------------------------------------------------------------------------------------------------------------------------------------------------------------------------------------------------------------------------------------------------------------------------------------------------------------------------------------------------------------------------------------------------------------------------------------------------------------------------------------------------------------------------------------------------------------------------------------------------------------------------------------------------------------------------------------------------------------------------------------------------------------------------------------------------------------------------------------------------------------------------------------------------------------------------------------------------------------------------------------------------------------------------------------------------------------------------------------------------------------------------------------------------------------------------------------------------------------------------------------------------------------------------------------------------------------------------------------------------------------------------------------------------------------------------------------------------------------------------	---------------------------------------------------------------------------------------------------------------------------------------------------------------------------------------------------------------------------------------------------------------------------------------------------------------------------------------------------------------------------------------------------------------------------------------------------------------------------------------------------------------------------------------------------------------------------------------------------------------------------------------------------------------------------------------------------------------------------------------------------------------------------------------------------------------------------------------------------------------------------------------------------------------------------------------------------------------------------------------------------------------------------------------------------------------------------------------------------------------------------------------------------------------------------------------------------------------------------------------------------------------------------------------------------------------------------------------------------------------------------------------------------------------------------------------------------------------------------------------------------------------------------------------------------------------------------------------------------------------------------------------------------------------------------------------------------------------------------------------------------

-Continued-

Table 1. Specifications (continued)

<p><b>Performance (continued)<sup>(5)</sup></b></p> <p>Electromagnetic Interference (EMI): Tested per IEC 61326-1:2013. Meets emission levels for Class A equipment (industrial locations) and Class B equipment (domestic locations). Meets immunity requirements for industrial locations (Table A.1 in the IEC specification document). Immunity performance is shown in table 2.</p> <p>Leak Sensitivity<sup>(4)</sup>: Less than 1.0% of span for up to 4.8 m<sup>3</sup>/hr (180 scfh) downstream leakage.</p> <p>Reverse Polarity Protection: No damage occurs from reversal of normal supply current (4 to 20 mA) or from misapplication of up to 100 mA.</p> <p><b>Connections</b></p> <p>Supply Air, Output Signal, and Output Gauge: 1/4-18 NPT internal connection Electrical: 1/2-14 NPT internal conduit connection</p> <p><b>Adjustments</b></p> <p>Zero and Span: screwdriver adjustments located in terminal compartment.</p> <p><b>Remote Pressure Reading (RPR) Jumper selectable, ON or OFF, if unit includes option</b></p> <p>Frequency Range: 0 to 10,000 Hz Amplitude: 0.4 to 1.0 V<sub>p-p</sub></p> <p><b>Required Operating Voltage with Remote pressure Reading Off</b></p> <p>Min. 6.0 V (at 4 mA) Max. 7.2 V (at 20 mA)</p> <p><b>Required Operating Voltage with Remote Pressure Reading On</b></p> <p>Min 6.4 V (at 4 mA) Max. 8.2 V (at 20 mA)</p>	<p><b>Hazardous Area Classifications</b></p> <p>cCSAus—Intrinsically Safe, Explosion-proof, Non-Incendive (Canada &amp; United States) FM—Intrinsically Safe, Explosion-proof, Non-Incendive (United States) ATEX—Intrinsically Safe, Flameproof, Type n IECEX—Intrinsically Safe, Flameproof CUTR— Customs Union Technical Regulations ESMA— Emirates Authority for Standardization and Metrology - ECAS-Ex (UAE) INMETRO— National Institute of Metrology, Quality, and Technology (Brazil) KTL— Korea Testing Laboratory (South Korea) CCC— China Compulsory Compliance NEPSI— National Supervision and Inspection Centre for Explosion Protection and Safety of Instrumentation (China) PESO CCOE— Petroleum and Explosives Safety Organization - Chief Controller of Explosives (India) UKEx—Intrinsically Safe &amp; Dust, Flameproof, Type n &amp; Dust (United Kingdom) Contact your <a href="#">Emerson sales office</a> or refer to the 846 product page at <a href="#">Fisher.com</a> for approval specific information</p> <p><b>Electrical Classification</b></p> <p>Pollution Degree 4</p> <p><b>Electrical Housing</b></p> <p>Tropicalization (Fungus test per MIL-STD-810) cCSAus—Type 4X FM—Type 4X ATEX—IP66<sup>(6)</sup> IECEX—IP66<sup>(6)</sup></p> <p><b>Construction Materials</b></p> <p>Housing: Low-copper aluminum with polyurethane paint, or 316 stainless steel O-Rings: Nitrile, except silicone for sensor O-rings.</p>
---------------------------------------------------------------------------------------------------------------------------------------------------------------------------------------------------------------------------------------------------------------------------------------------------------------------------------------------------------------------------------------------------------------------------------------------------------------------------------------------------------------------------------------------------------------------------------------------------------------------------------------------------------------------------------------------------------------------------------------------------------------------------------------------------------------------------------------------------------------------------------------------------------------------------------------------------------------------------------------------------------------------------------------------------------------------------------------------------------------------------------------------------------------------------------------------------------------------------------------------------------------------------------------------------------------------------------------------------------------------------------------------------------	------------------------------------------------------------------------------------------------------------------------------------------------------------------------------------------------------------------------------------------------------------------------------------------------------------------------------------------------------------------------------------------------------------------------------------------------------------------------------------------------------------------------------------------------------------------------------------------------------------------------------------------------------------------------------------------------------------------------------------------------------------------------------------------------------------------------------------------------------------------------------------------------------------------------------------------------------------------------------------------------------------------------------------------------------------------------------------------------------------------------------------------------------------------------------------------------------------------------------------------------------------------------------------------------------------------------------------------------------------------------------------------------------------------------------------------------------------------------------------------------------------------------------

-continued-

Table 1. Specifications (continued)

<p><b>Options</b></p> <p>Fisher 67CFR filter regulator, supply and output gauges or tire valve remote pressure reading, module cover with multiple stroke ports, stainless steel housing, or stainless steel mounting bracket.</p> <p><b>Altitude Rating</b></p> <p>Up to 2000 meters (6562 feet)</p> <p><b>Weight</b></p> <p><b>Aluminum:</b> 2.9 kg (6.5 lb) excluding options  <b>Stainless Steel:</b> 6.7 kg (14.8 lb) excluding options</p>	<p><b>Declaration of SEP</b></p> <p>Fisher Controls International LLC declares this product to be in compliance with Article 4 paragraph 3 of the PED Directive 2014/68/EU and Part 1, Requirement 8 of the PESR Regulation. It was designed and manufactured in accordance with Sound Engineering Practice (SEP) and cannot bear the CE marking related to PED compliance or the UKCA mark related to the PESR Regulation.</p> <p>However, the product may bear the CE or UKCA marking to indicate compliance with other applicable European Community Directives or UK Regulations (Statutory Instruments).</p>
------------------------------------------------------------------------------------------------------------------------------------------------------------------------------------------------------------------------------------------------------------------------------------------------------------------------------------------------------------------------------------------------------------------------------------------------------	-------------------------------------------------------------------------------------------------------------------------------------------------------------------------------------------------------------------------------------------------------------------------------------------------------------------------------------------------------------------------------------------------------------------------------------------------------------------------------------------------------------------------------------------------------------------------------------------------------------------

NOTE: Specialized instrument terms are defined in ANSI/ISA Standard 51.1 - Process Instrument Terminology.  
 1. Metric calibration also available.  
 2. The pressure/temperature limits in this document, and any applicable standard or code limitation should not be exceeded.  
 3. 0.14 bar (2 psi) for a 2.3 bar (33 psi) output.  
 4. Normal m<sup>3</sup>/hr—Normal cubic meters per hour (0°C and 1.01325 bar, absolute). Scfh—Standard cubic feet per hour (60°F and 14.7 psia).  
 5. Reference Conditions: 4.0 to 20 mA DC input, 0.2 to 1.0 bar (3 to 15 psi) output, and 1.4 bar (20 psi) supply pressure.  
 6. ATEX and IECEx Flameproof — IP66 per CSA Letter of Attestation.

Table 2. EMC Immunity Performance Criteria

Port	Phenomenon	Basic Standard	Test Level	Performance Criteria <sup>(1)</sup>
Enclosure	Electrostatic discharge (ESD)	IEC 61000-4-2	4 kV contact 8 kV air	A
	Radiated EM field	IEC 61000-4-3	80 to 1000 MHz @ 10V/m with 1 kHz AM at 80% 1400 to 2000 MHz @ 3V/m with 1kHz AM at 80% 2000 to 2700 MHz @ 1V/m with 1kHz AM at 80%	A
I/O signal/control	Burst (fast transients)	IEC 61000-4-4	1 kV	A
	Surge	IEC 61000-4-5	1 kV (line to ground only, each)	B
	Conducted RF	IEC 61000-4-6	150 kHz to 8 MHz at 3 Vrms	B
8 MHz to 80 MHz at 3 Vrms			A	

Specification limit = ±1% of span  
 1. A = No degradation during testing. B = Temporary degradation during testing, but is self-recovering.

## Educational Services

Emerson Educational Services  
 Phone: +1-800-338-8158  
 Email: education@emerson.com  
 emerson.com/mytraining

Figure 2. Transducer Modular Construction

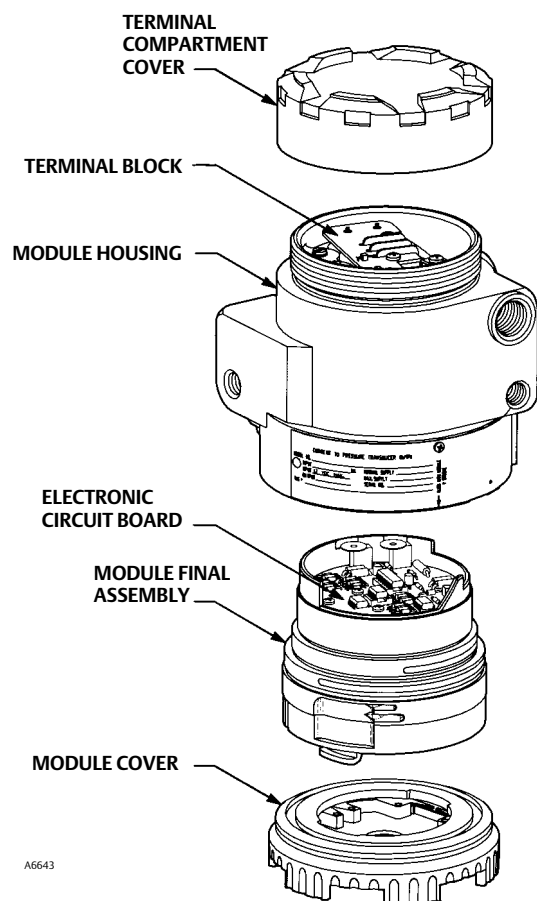
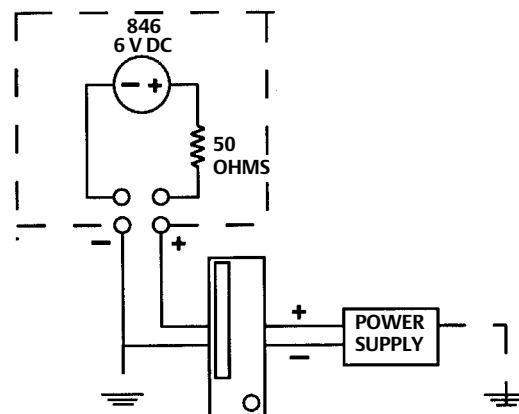

Figure 3. Equivalent Circuit



NOTE:  
THE 846 IS NOT A CONSTANT RESISTOR IN SERIES WITH AN INDUCTOR.  
IT IS BETTER MODELED IN THE LOOP AS A 50 OHM RESISTOR IN SERIES  
WITH A 6-VOLT DC VOLTAGE DROP WITH NEGLIGIBLE INDUCTANCE.

A6325

## Installation

### ⚠ WARNING

To avoid personal injury or property damage from the sudden release of pressure or air:

- Always wear protective clothing, gloves, and eyewear when performing any installation operations.
- Disconnect any operating lines providing air pressure, electric power, or a control signal to the actuator. Be sure the actuator cannot suddenly open or close the valve.
- Use bypass valves or completely shut off the process to isolate the valve from process pressure. Relieve process pressure on both sides of the valve.
- Use lock-out procedures to be sure that the above measures stay in effect while you work on the equipment.
- Check with your process or safety engineer for any additional measures that must be taken to protect against process media.

**NOTICE**

**Do not use sealing tape on pneumatic connections. This instrument contains small passages that may become obstructed by detached sealing tape. Thread sealant paste should be used to seal and lubricate pneumatic threaded connections.**

This section presents information on installing the 846 electro-pneumatic transducer. Figures 4, 5, 6, and 8 can be used as references for instructions contained in this section.

When a control valve is ordered with an 846 transducer specified to be mounted on the actuator, the factory-mounted transducer is connected to the actuator with the necessary tubing and calibrated to the specifications on the order.

If the transducer is purchased separately for mounting on a control valve already in service, all the necessary mounting parts are furnished, if ordered. This includes the appropriate bracket for attaching the unit to an actuator boss (with tapped holes) or for attaching it to the diaphragm casing.

If preferred, mounting parts can be supplied for mounting the transducer on a 51 mm (2-inch) diameter pipestand, a flat surface, or a bulkhead.

Transducers also can be ordered separately for mounting on a control valve assembly already in service. The transducer may be ordered with or without mounting parts. Mounting parts include the appropriate bracket and bolts for attaching the unit to an actuator boss (with tapped holes) or for attaching it to the diaphragm casing.

## Hazardous Area Classifications and Special Instructions for “Safe Use” and Installation in Hazardous Locations

Refer to the following instruction manual supplements for approval information.

- CSA Approval Information for Fisher 846 Electro-Pneumatic Transducers ([D104218X012](#))
- FM Approval Information for Fisher 846 Electro-Pneumatic Transducers ([D104219X012](#))
- ATEX Approval Information for 846 Electro-Pneumatic Transducers ([D104220X012](#))
- IECEx Approval Information for 846 Electro-Pneumatic Transducers ([D104221X012](#))
- INMETRO Approval Information for Fisher 846 Electro-Pneumatic Transducers ([D103623X012](#))
- NEPSI Approval Information for Fisher 846 Electro-Pneumatic Transducers ([D103618X012](#))

Documents are available from your [Emerson sales office](#) or Fisher.com. Contact your Emerson sales office for all other approval information.

---

## Mounting

---

### Note

This unit will vent to the atmosphere through the stroke port in the module cover and the exhaust port, located under the nameplate. Do not remote vent this unit.

---

The transducer is designed for mounting on a control valve, 51 mm (2-inch) diameter pipestand, wall, or panel. Figures 5, 6, 7, and 8 show recommended mounting configurations. The mounting positions shown allow any moisture buildup in the terminal compartment to drain to the signal wire conduit entrance. Any moisture in the pilot stage area will be expelled through the stroke port without affecting pilot stage operation. In applications with excessive moisture in the supply air, vertical mounting allows the most effective drainage through the stroke port.

### NOTICE

**Do not mount the transducer with the terminal compartment cover on the bottom as moisture, or any corrosive elements in the plant atmosphere, may accumulate in the terminal compartment or pilot stage, resulting in transducer malfunction.**

---

Mounting is accomplished with an optional universal mounting bracket. Before mounting the transducer, note the following recommendations:

- Ensure that all bolts are fully tightened. The recommended torque is 22 N•m (16 lbf•ft).
- Bolts that connect to the transducer and to a valve actuator should have the lock washer placed directly beneath the bolt head and the flat washer placed between the lock washer and bracket. All other bolts should have the lock washer next to the nut, and the flat washer placed between the lock washer and bracket.
- Do not mount the transducer in a location where foreign material may cover the stroke port or exhaust port. See the descriptions of the stroke port and exhaust port later in this section.

## Pressure Connections

### NOTICE

**Do not use sealing tape on pneumatic connections. This instrument contains small passages that may become obstructed by detached sealing tape. Thread sealant paste should be used to seal and lubricate pneumatic threaded connections.**

---

As shown in figure 4, all pressure connections are 1/4-18 NPT internal connections. Use 9.5 mm (3/8-inch) outside diameter tubing for the supply and output connections.



Figure 4. Typical Dimensions and Connection Locations (Aluminum Construction Shown)

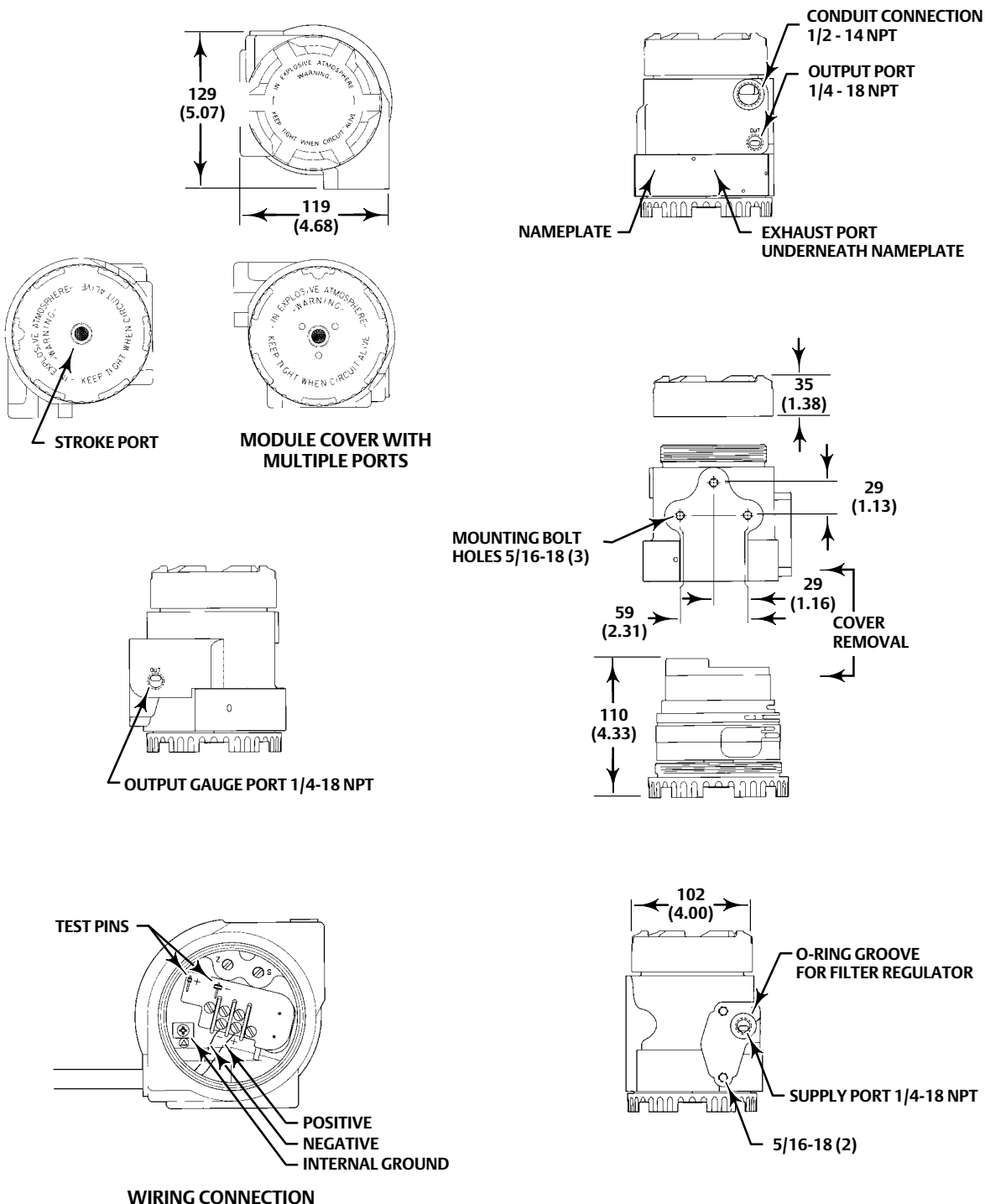

NOTE:  
REFER TO FIGURE 8 FOR TRANSDUCER DIMENSIONS WITH  
ATEX / IECEx FLAMEPROOF CERTIFICATIONS

mm  
(INCHES)

B2473-1

## Supply Pressure

### **⚠ WARNING**

Severe personal injury or property damage may occur from process instability if the instrument supply medium is not clean, dry air. While use and regular maintenance of a filter that removes particles larger than 40 micrometers in diameter will suffice in most applications, check with an Emerson field office and industry instrument air quality standards if you are unsure about the proper amount or method of air filtration or filter maintenance.

The supply medium must be clean, dry air that meets the requirements of ISA Standard 7.0.01 or ISO 8573-1. An output span of 0.2 to 1.0 bar (3 to 15 psi) requires a nominal supply pressure of 1.4 bar (20 psi) and a flow capacity not less than 6.4 normal m<sup>3</sup>/hr (240 scfh).

For multirange performance units with higher output spans, the supply pressure should be at least 0.2 bar (3 psi) greater than the maximum calibrated output pressure.

The air supply line can be connected to the 1/4-18 NPT supply port, or to the supply port of a filter-regulator mounted directly to the transducer. Figures 5, 6, 7, and 8 show the installation options.

Figure 5. Typical Dimensions with Fisher 67CFR Filter/Regulator and Gauges

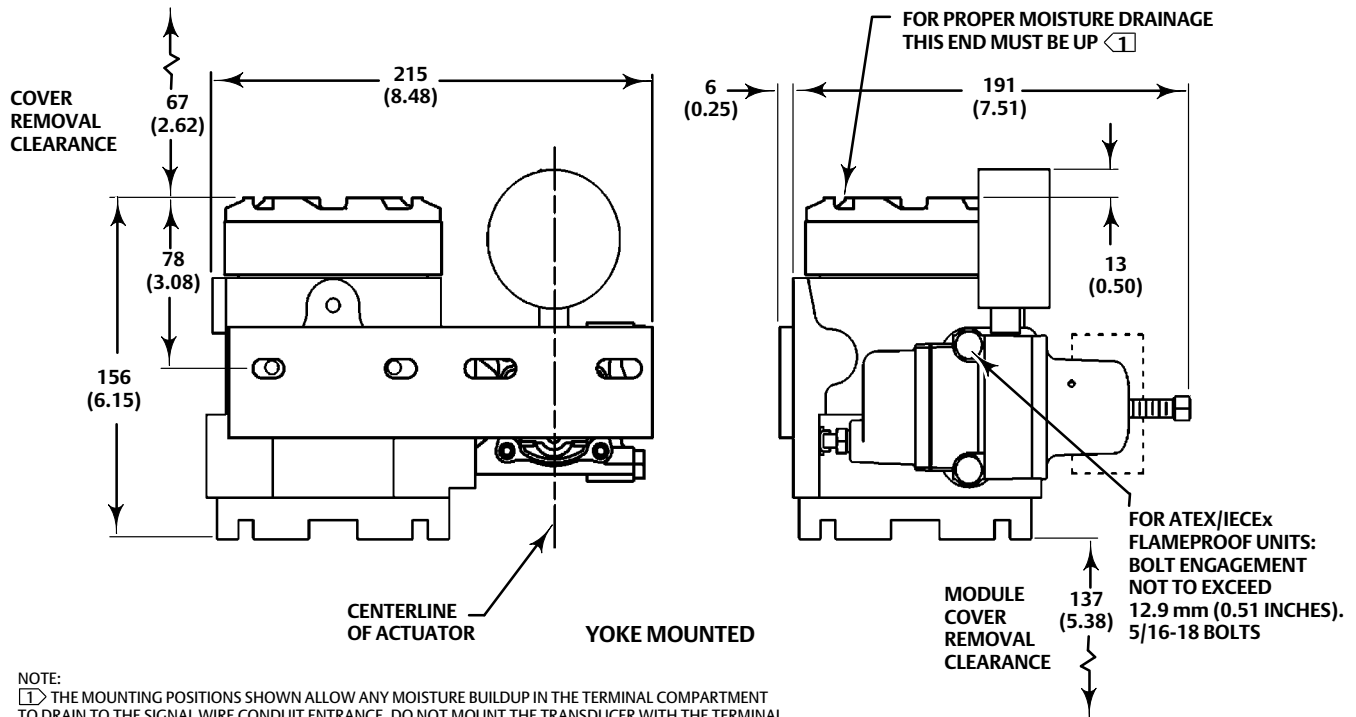

mm  
(INCH)

Figure 6. Typical Transducer Mounting with Universal Mounting Bracket

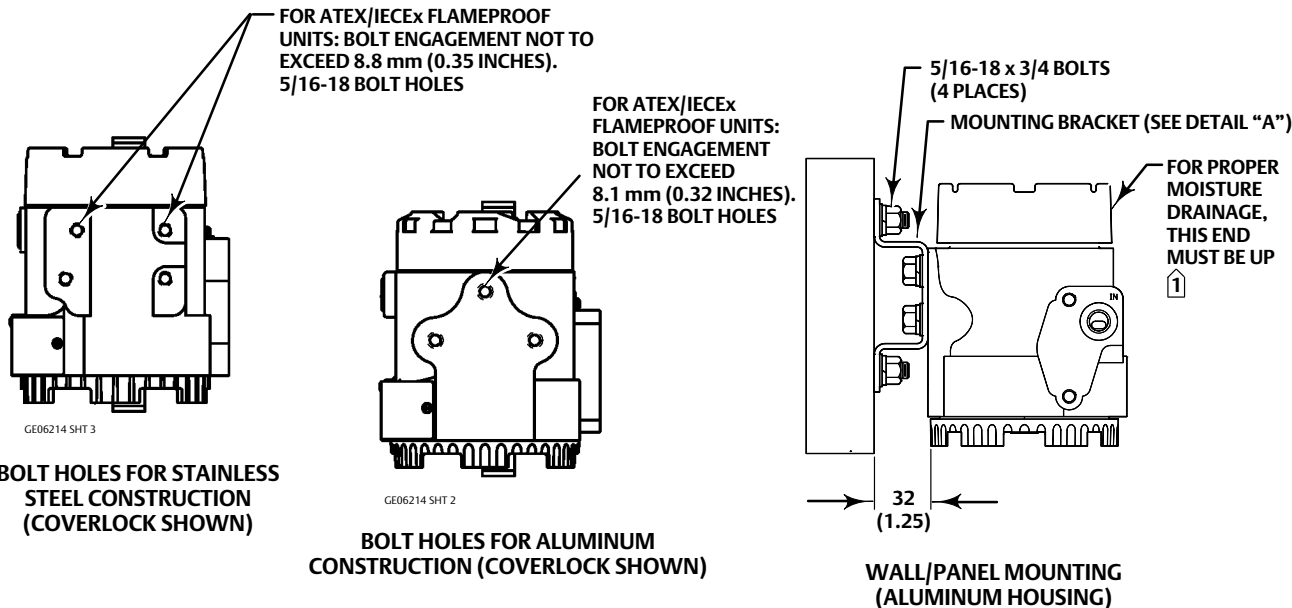
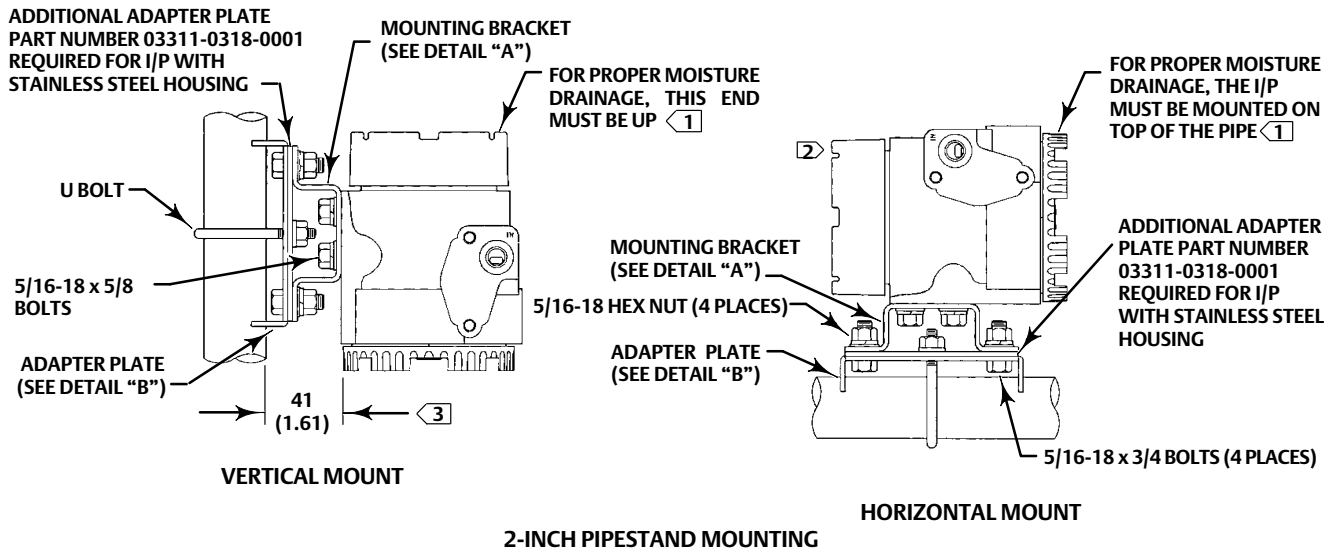

NOTES:

- 1** THE MOUNTING POSITIONS SHOWN ALLOW ANY MOISTURE BUILDUP IN THE TERMINAL COMPARTMENT TO DRAIN TO THE SIGNAL WIRE CONDUIT ENTRANCE. DO NOT MOUNT THE TRANSDUCER WITH THE TERMINAL COMPARTMENT COVER ON THE BOTTOM; MOISTURE MAY ACCUMULATE IN THE TERMINAL COMPARTMENT OR PILOT STAGE, PREVENTING PROPER TRANSDUCER OPERATION. THE VERTICAL MOUNT IS MOST EFFECTIVE FOR MOISTURE DRAINAGE IN WET APPLICATIONS.
- 2** IF MOUNTED ON HORIZONTAL PIPE, THE I/P MUST BE ON TOP OF THE PIPE FOR PROPER MOISTURE DRAINAGE.
- 3** THIS DIMENSION IS 44 (1.74) FOR STAINLESS STEEL HOUSING.

mm  
(INCH)

1487332  
1989484-B  
E0786

Figure 6. Typical Transducer Mounting with Universal Mounting Bracket (continued)

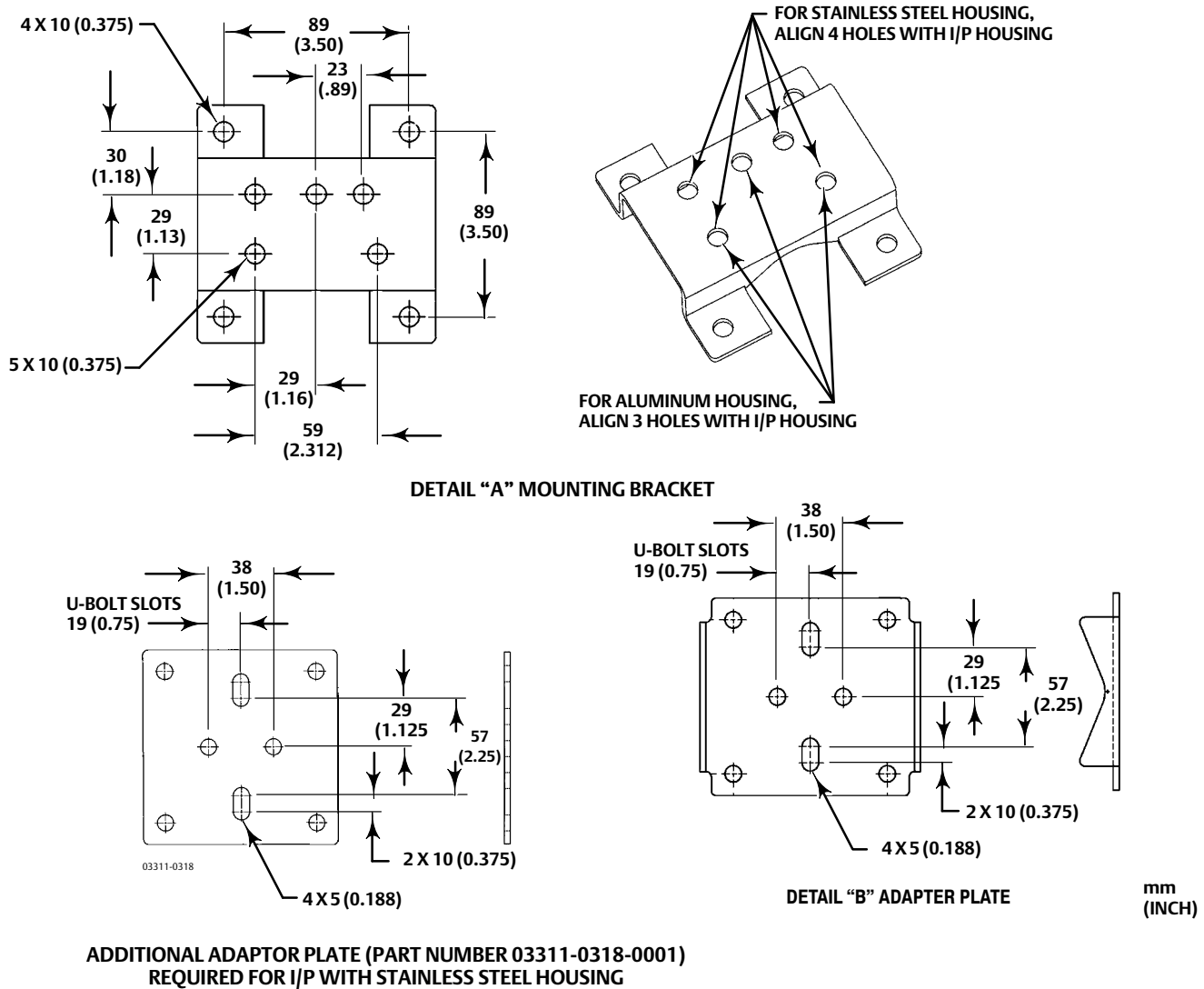

NOTES:

1. ATTACH THE BRACKET SHOWN IN DETAIL "A" TO THE TRANSDUCER
2. ATTACH THE ADAPTER PLATE SHOWN IN DETAIL "B" TO THE VALVE OR PIPE.
3. CONNECT THE TWO PIECES.

34B4990-C  
34B5000-B  
E0787

The mounting boss for the air supply connection contains two 5/16-18 UNC tapped holes that are 2-1/4 inches apart. The tapped holes allow direct connection (integral mount) of a 67CFR filter-regulator, if desired. When the filter-regulator is factory mounted, the mounting hardware consists of two 5/16-18 x 3-1/2 inch stainless steel bolts and one O-ring. When the filter-regulator is field mounted, the mounting hardware consists of two 5/16-18 x 3-1/2 inch stainless steel bolts, two spacers (which may or may not be required) and two O-rings (of which only one will fit correctly into the housing O-ring groove and the other may be discarded). This is due to the fact that the current housing has been slightly modified from its original design, hence, the additional hardware (if needed) when field mounting the 67CFR filter-regulator.

Figure 7. Typical Transducer Dimensions with Gauges

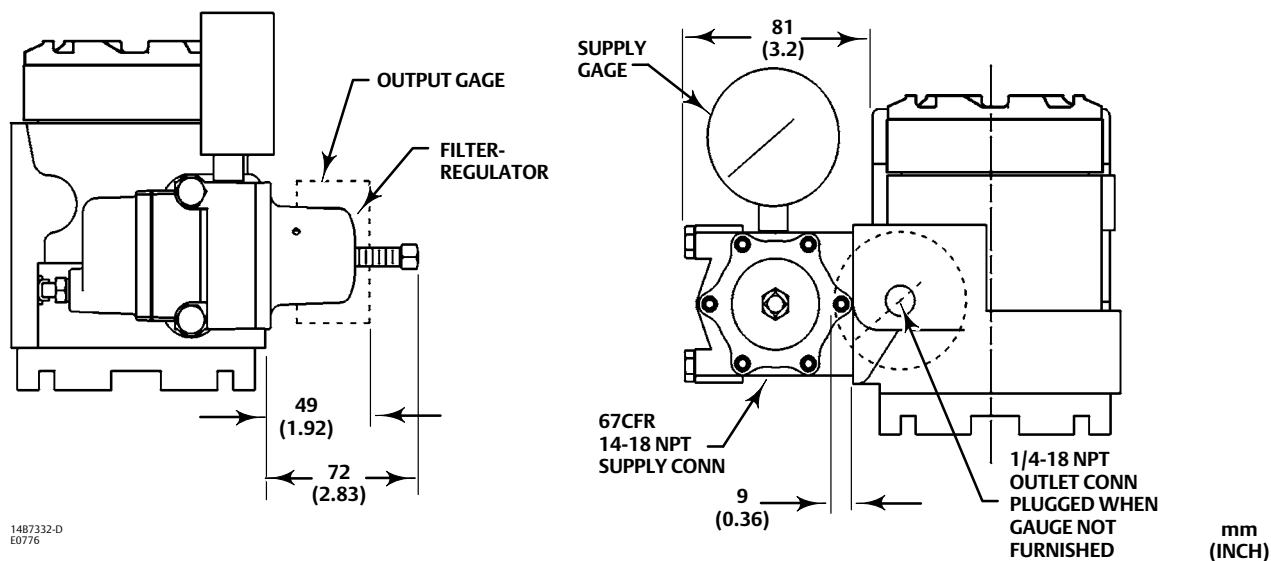

1487332-D  
E0776

Figure 8. Transducer Dimensions with ATEX / IECEx Flameproof Certifications

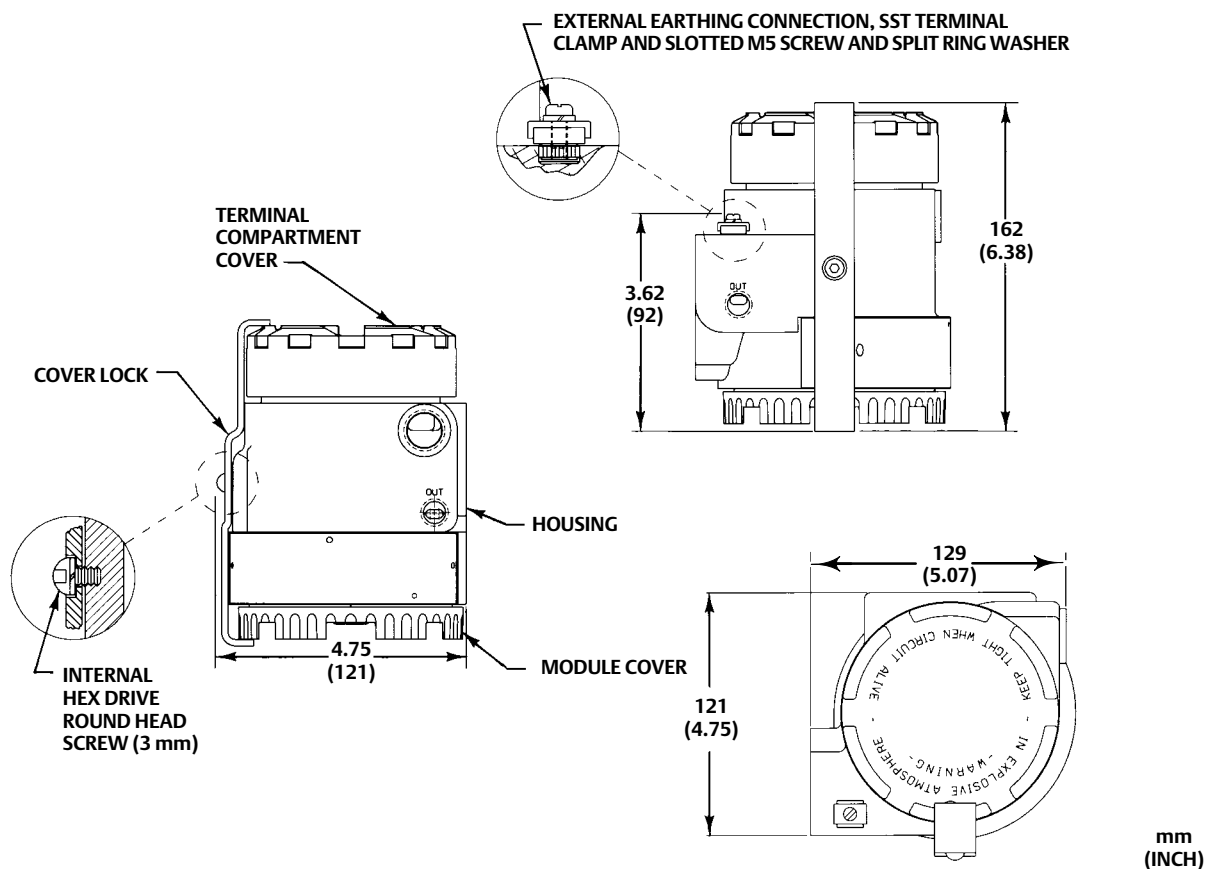

82465

## Output Pressure

Connect the output signal line to the transducer at the output port. The output port is 1/4-18 NPT, as shown in figure 4. The output gauge port can be used as an alternate signal port. If the gauge port is used as a signal port, a threaded plug must be installed in the output port.

The output gauge port allows connection of an output gauge to provide local output signal indication. The output gauge port is 1/4-18 NPT. If an output gauge is not specified, a threaded plug is shipped with the transducer. The plug must be installed in the output gauge port when the port is not used.

## Electrical Connections

### **⚠ WARNING**

**Personal injury or property damage could result from fire or explosion. In explosive atmospheres, remove power and shut off the air supply to the I/P unit before attempting to remove the terminal compartment cover or module cover. Failure to do so could result in an electrical spark or explosion.**

**Personal injury or property damage could result from an uncontrolled process. Perform the steps in the WARNING at the beginning of the Installation section before removing the module cover to ensure the process is properly controlled. Unscrewing the module cover removes power from the electronics and opens the supply and output air passages to atmosphere resulting in an output signal of 0.0 psi.**

### **NOTICE**

**Excessive current can damage the transducer. Do not connect an input current of more than 100 mA to the transducer.**

### **Note**

For North American explosion-proof applications, 846 transducers have been designed so that a conduit seal is not required. For all other applications install the product per local, regional, or national code, rules, and regulations.

### **⚠ WARNING**

**Select wiring and/or cable glands that are rated for the environment of use (such as hazardous location, ingress protection, and temperature). Failure to use properly rated wiring and/or cable glands can result in personal injury or property damage from fire or explosion.**

Signal wiring is brought to the terminal compartment through a 1/2-14 NPT housing conduit connection, shown in figure 4. Where condensate is common, use a conduit drip leg to help reduce liquid buildup in the terminal compartment and avoid shorting of the input signal. Electrical connections are made at the terminal block. Internal and external grounding lugs are provided to facilitate a separate ground when required. The internal ground is shown in figure 4, and the external grounding lug is shown in figure 8.

Connect the positive signal lead to the positive terminal, marked +. Connect the negative signal lead to the negative terminal, marked -.

---

**Note**

Units with the Remote Pressure Reading (RPR) option may cause interference with the analog output signal from some instrumentation systems. This problem may be solved by placing a 0.2 microfarad capacitor or a HART filter across the output terminals.

---

## Venting Ports

---

**Note**

This unit will vent to the atmosphere through the stroke port in the module cover and the exhaust port, located under the nameplate. Do not remote vent this unit.

---

## Stroke Port

The constant bleed of supply medium from the pilot stage is directed out the stroke port, which is a screened hole located at the center of the module cover. Figure 4 shows the location of the stroke port.

Before installing the transducer, ensure the stroke port is clear. Do not mount the transducer in a location where foreign material may cover the stroke port. For information on using the stroke port, refer to the Troubleshooting section.

## Exhaust Port

The transducer exhausts through a screened port located beneath the instrument nameplate. Figure 4 shows the location of the exhaust port. The nameplate holds the screen in place. Exhaust will occur with a reduction in output pressure. The transducer should not be mounted in a location where foreign material may clog the exhaust port.

## Signal Interruption

Upon loss of input current, or if input current decreases below  $3.3 \pm 0.3$  mA, the output of the direct action unit will decrease to less than 0.1 bar (1 psi).

In the same situation, the output of the reverse action unit will increase to near supply pressure.

## Calibration

### **⚠ WARNING**

The following calibration procedures require taking the transducer out of service. To avoid personal injury and property damage caused by an uncontrolled process, provide some temporary means of control for the process before taking the transducer out of service. Also refer to the **WARNING** at the beginning of the Maintenance section.

Calibration of the 846 requires either an accurate current generator or an accurate voltage generator with a precision 250-ohm, 1/2-watt resistor. Figure 9 shows how to connect either device.

Calibration also requires a precision output indicator and a minimum non-surging air supply of 5.0 normal m<sup>3</sup>/hr (187 scfh) at 1.4 bar (20 psi) for standard performance units. For multirange performance units, the air supply must be at least 0.2 bar (3 psi) greater than the maximum calibrated output pressure, up to 2.4 bar (35 psi) maximum.

For ease of calibration, the output load volume, including the output tubing and output indicator, should be a minimum of 33 cm<sup>3</sup> (2 cubic inches). Review the information under Signal Interruption in the Installation section before beginning the calibration procedure.

Before calibration, determine the type of input (full or split range), and the type of output action (direct or reverse). Consult the factory for split range output calibration. Also, determine if the unit offers standard or multirange performance. The unit supports eight basic input/output combinations:

#### Standard Performance

- Full Range Input, Direct Action
- Split Range Input, Direct Action
- Full Range Input, Reverse Action
- Split Range Input, Reverse Action

#### Multirange Performance

- Full Range Input, Direct Action
- Split Range Input, Direct Action (see note below)
- Full Range Input, Reverse Action
- Split Range Input, Reverse Action (see note below)

---

#### Note

Consult your [Emerson sales office](#) for calibration of multirange performance units with split range input or split range output, or both.

---



Figure 9. Connecting a Current or Voltage Source for Calibration

ADJUST THE CURRENT SOURCE TO PROVIDE THE 4 AND 20 mA SET POINTS

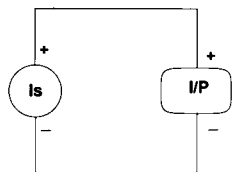

CALIBRATION USING A CURRENT SOURCE

TO OBTAIN THE 4 AND 20 mA SET POINTS, ADJUST THE VOLTAGE SOURCE ( $V_s$ ) SO THE VOLTMETER ( $V_m$ ) READS 1 AND 5 VOLTS, RESPECTIVELY, ACROSS THE 250 ohm RESISTOR

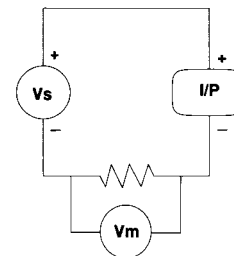

CALIBRATION USING A VOLTAGE SOURCE

A6644-1

**NOTICE**

Excessive current can damage the transducer. Do not connect an input current of more than 100 mA to the transducer.

Table 3 lists the various input and output ranges over which the unit may be calibrated.

The input range is selected by changing the position of a jumper located on the electronic circuit board.

Refer to Electronic Circuit Board in the Maintenance section, and figure 18 for the location and instruction on placement.

Table 3. Fisher 846 I/P Rangeability Matrix

Input Range	Output Pressure Range (psi) (Performance Code)															
	Common Ranges					Misc.	Std. Split		High Range Splits							
	3-15 (S,M)	.5-30 (M)	3-27 (M)	6-30 (M)	5-25 (M)	0.5-6 (S,M)	.5-18 (S,M)	3-9 (S,M)	9-15 (S,M)	.5-15 (S,M)	15-30 (M)	15-27 (M)	6-18 (S,M)	18-30 (M)	5-15 (S,M)	15-25 (M)
4-20	✓	✓	✓	✓	✓	D	✓	D	D	✓	U	U	✓	U	✓	U
4-12	✓	✓	✓	✓	✓	D	✓	D	D	✓	U	U	✓	U	✓	U
12-20	✓		J	J	J	D	J	D	D	J	✓	✓	✓	✓	✓	✓
4-8	✓					✓		✓	✓				✓		✓	
8-12	✓					J		J	J				J		J	
12-16	J					J		J	J				J		J	
16-20	J					J		J	J				J		J	

S=Standard Performance Unit  
M=Multirange Performance Unit  
✓=Available in Direct or Reverse Action  
D=Available in Direct Action Only  
J=Available, but if the desired calibration cannot be achieved by adjusting the zero/span screws, unit may require Hi/Lo jumper to be moved. The jumper is located on the circuit board assembly, and is usually in the Hi position. Disengaging the master module and moving the jumper to the Lo position will allow calibration to the desired range.  
U=Special Build Required.

## Standard Performance: Full Range Input, Direct Action

### **⚠ WARNING**

Refer to the **WARNING** at the beginning of the Maintenance section.

---

Use the following procedure to achieve a standard 0.2 to 1.0 bar (3 to 15 psi) output span for a 4 to 20 mA input signal:

1. Remove the module final assembly from the housing. Refer to Removing the Module Final Assembly in the Maintenance section for an explanation of how to disengage the module final assembly.
2. Confirm that the unit is direct acting. A green electronic circuit board identifies direct-acting units. Refer to Action under the heading Electronic Circuit Board in the Maintenance section for more information on direct acting units.
3. Position the range jumper in the Hi position for High Range. Figure 18 shows the circuit board jumper positions.
4. Replace the module final assembly in the housing. Refer to Replacing the Module Final Assembly in the Maintenance section for an explanation of how to engage the module final assembly.
5. Connect the air supply to the air supply port.
6. Connect a precision output indicator to the output signal port.
7. Make sure that the output gauge port has an output gauge or a threaded plug installed. A threaded plug is provided for units shipped without output gauges.
8. Remove the terminal compartment cover.
9. Connect the current source (or voltage source) positive lead (+) to the terminal block positive (+) and the current source (250-ohm resistor lead) negative lead (-) to the terminal block negative (-). Refer to figure 9.

### **NOTICE**

Excessive current can damage the transducer. Do not connect an input current of more than 100 mA to the transducer.

---

10. Apply a 4.0 mA ( $V_m = 1.0$  V) signal, and adjust the zero screw to achieve a 0.2 bar (3.0 psi) output. The output increases with clockwise rotation of the zero screw.
11. Apply a 20.0 mA ( $V_m = 5.0$  V) signal, and adjust the span screw to achieve a 1.0 bar (15.0 psi) output. The output increases with clockwise rotation of the span screw.
12. Repeat steps 10 and 11 to verify and complete the calibration.

## Multirange Performance: Full Range Input, Direct Action

### **⚠ WARNING**

Refer to the **WARNING** at the beginning of the Maintenance section.

---

#### **Note**

Consult your [Emerson sales office](#) for calibration of multirange performance units with split range input.

---

Use the following procedure with a multirange performance unit to achieve the desired direct action output span for a 4 to 20 mA input signal:

1. Perform steps 1 through 9 of the calibration procedure for Standard Performance: Full Range Input, Direct Action.
2. Apply a 4.0 mA ( $V_m = 1.0$  V) signal, and adjust the zero screw to achieve the desired lower limit of the output range. The lower limit must be between 0.03 and 0.6 bar (0.5 and 9.0 psi). The output increases with clockwise rotation of the zero screw.
3. Apply a 20.0 mA ( $V_m = 5.0$  V) signal, and adjust the span screw to achieve the desired upper limit of the output range. The span must be at least 0.4 bar (6.0 psi). The maximum upper limit is 2.0 bar (30.0 psi). The output increases with clockwise rotation of the span screw.
4. Repeat steps 2 and 3 to verify and complete the calibration.

## Standard Performance: Split Range Input, Direct Action

### WARNING

Refer to the **WARNING** at the beginning of the Maintenance section.

### 4 to 12 mA Input Signal

Use the following calibration procedure to produce a 0.2 to 1.0 bar (3 to 15 psi) output span for a 4 to 12 mA input signal:

1. Perform steps 1 through 9 of the calibration procedure for Standard Performance: Full Range Input, Direct Action.
2. Apply an input of 4.0 mA ( $V_m = 1.0$  V), and adjust the zero screw to achieve an output of 0.2 bar (3.0 psi).
3. Apply an input of 12.0 mA ( $V_m = 3.0$  V), and adjust the span screw to achieve an output of 1.0 bar (15.0 psi).
4. Repeat steps 2 and 3 to verify and complete the calibration.

### 12 to 20 mA Input Signal

Use the following calibration procedure to produce a 0.2 to 1.0 bar (3 to 15 psi) output span for a 12 to 20 mA input signal:

---

#### Note

There may be some span interaction with zero in this range, and the following steps compensate for this.

---

1. Perform steps 1 through 9 of the calibration procedure for Standard Performance: Full Range Input, Direct Action.
2. Apply an input of 4.0 mA ( $V_m = 1.0$  V), and adjust the zero screw to achieve an output of 0.2 bar (3.0 psi).
3. Apply an input of 12.0 mA ( $V_m = 3.0$  V), and adjust the span screw to achieve an output of 1.0 bar (15.0 psi).
4. Maintain the input of 12.0 mA ( $V_m = 3.0$  V), and adjust the zero screw to achieve an output of 0.2 bar (3.0 psi). The unit may not turn down this low; if it does not, go to step 7.
5. If the output reaches 0.2 bar (3.0 psi) in step 4, apply an input of 20.0 ma ( $V_m = 5.0$  V) and note the error (the actual reading versus 15.0 psi). Adjust the span screw to overcorrect the error by a factor of two. For example, if the reading was 0.9 bar (14.95 psi), adjust the span screw to achieve an output of 1.1 bar (15.05 psi).

6. Repeat steps 4 and 5 to verify and complete the calibration.
7. Turn off the air supply. Remove the module final assembly from the housing. Place the range jumper in the Lo position for Low Range, as indicated in figure 18. Replace the module final assembly. Turn on the air supply.
8. Apply an input of 12.0 mA ( $V_m = 3.0$  V), and adjust the zero screw to achieve an output of 0.2 bar (3.0 psi).
9. Apply an input of 20.0 mA ( $V_m = 5.0$  V), and note the error (the actual reading versus 15.0 psi). Adjust the span screw to overcorrect the error by a factor of two. For example, if the reading was 0.9 bar (14.95 psi), adjust the span screw to achieve an output of 1.1 bar (15.05 psi).
10. Repeat steps 8 and 9 to verify and complete the calibration.

## Standard Performance: Full Range Input, Reverse Action

### **⚠ WARNING**

Refer to the **WARNING** at the beginning of the Maintenance section.

Use the following procedure on reverse action units to achieve a 1.0 to 0.2 bar (15 to 3 psi) output span for a 4 to 20 mA input signal:

1. Perform steps 1 through 9 under Standard Performance: Full Range Input, Direct Action, except for step 2. In place of step 2, confirm that the unit is reverse acting. A blue electronic circuit board identifies reverse-acting units. Refer to Action under the heading Electronic Circuit Board in the Maintenance section for more information on reverse acting units.
2. Apply an input of 4.0 mA ( $V_m = 1.0$  V), and adjust the zero screw to achieve an output of 1.0 bar (15.0 psi).
3. Apply an input of 20.0 mA ( $V_m = 5.0$  V), and adjust the span screw to achieve an output of 0.2 bar (3.0 psi).
4. Repeat steps 2 and 3 to verify and complete the calibration.

## Multirange Performance: Full Range Input, Reverse Action

### **⚠ WARNING**

Refer to the **WARNING** at the beginning of the Maintenance section.

#### **Note**

Consult your [Emerson sales office](#) for calibration of multirange performance units with split range input.

Use the following procedure with a multirange unit to achieve the desired reverse action output span for a 4 to 20 mA input signal:

1. Perform steps 1 through 9 of the calibration procedure for Standard Performance: Full Range Input, Direct Action, except for step 2. In place of step 2, confirm that the unit is reverse acting. A blue electronic circuit board identifies reverse-acting units. Refer to Action under the heading Electronic Circuit Board in the Maintenance section for more information on reverse acting units.
2. Apply an input of 4.0 mA ( $V_m = 1.0$  V), and adjust the zero screw to achieve the desired upper limit of the output range. The 4 mA point must be between 0.6 and 2.0 bar (9.0 and 30.0 psi). The output increases with clockwise rotation of the zero screw.

3. Apply an input of 20.0 mA ( $V_m = 5.0$  V), and adjust the span screw to achieve the desired lower limit of the output range. The span must be at least 0.7 bar (11.0 psi). The lower limit of the 20.0 mA setting is 0.03 bar (0.5 psi). The output increases with clockwise rotation of the span screw.
4. Repeat steps 2 and 3 to verify and complete the calibration.

## Standard Performance: Split Range Input, Reverse Action

### **⚠ WARNING**

Refer to the **WARNING** at the beginning of the Maintenance section.

### 4 to 12 mA Input Signal

Use the following procedure on reverse action units to achieve a 1.0 to 0.2 bar (15 to 3 psi) output signal for a 4 to 12 mA input signal:

1. Perform steps 1 through 9 of the calibration procedure for Standard Performance: Full Range Input, Direct Action, except for step 2. In place of step 2, confirm that the unit is reverse acting. A blue electronic circuit board identifies reverse-acting units. Refer to Action under the heading Electronic Circuit Board in the Maintenance section for more information on reverse acting units.
2. Apply an input of 4.0 mA ( $V_m = 1.0$  V), and adjust the zero screw to achieve an output of 1.0 bar (15.0 psi).
3. Apply an input of 12.0 mA ( $V_m = 3.0$  V), and adjust the span screw to achieve an output of 0.2 bar (3.0 psi).
4. Repeat steps 2 and 3 to verify and complete the calibration.

### 12 to 20 mA Input Signal

Use the following procedure on reverse action units to achieve a 1.0 to 0.2 bar (15 to 3 psi) output signal for a 12 to 20 mA input signal:

---

#### **Note**

There may be some span interaction with zero in this range, and the following steps compensate for this.

---

1. Perform steps 1 through 9 of the calibration procedure for Standard Performance: Full Range Input, Direct Action, except for step 2. In place of step 2, confirm that the unit is reverse action. A blue electronic circuit board identifies reverse-acting units. Refer to Action under the heading Electronic Circuit Board in the Maintenance section for more information on reverse acting units.
2. Apply an input of 4.0 mA ( $V_m = 1.0$  V), and adjust the zero screw to achieve an output of 1.0 bar (15.0 psi).
3. Apply an input of 12.0 mA ( $V_m = 3.0$  V), and adjust the span screw to achieve an output of 0.2 bar (3.0 psi).
4. Maintain the input of 12.0 mA ( $V_m = 3.0$  V), and adjust the zero screw to achieve an output of 1.0 bar (15.0 psi). The unit may not turn up this high; if it does not, go to step 7.
5. If the output reaches 15.0 psi in step 4, apply an input of 20 mA, and adjust the span screw to achieve a 3.0 psi output. Apply an input of 20 mA ( $V_m = 5.0$  V), and note the error (the actual reading versus 3.0 psi). Adjust the span screw to overcorrect the error by a factor of two. For example, if the reading was 2.95 psi, adjust the span screw to achieve an output of 3.05 psi.

6. Repeat steps 4 and 5 to verify and complete the calibration.
7. If the 12.0 mA ( $V_m = 3.0$  V) cannot be adjusted to 1.0 bar (15.0 psi) in step 4, turn off the air supply. Remove the module final assembly from the housing. Place the range jumper in the Lo position for Low Range, as shown in figure 18. Replace the module final assembly. Turn on the air supply.
8. Apply an input of 12.0 mA ( $V_m = 3.0$  V), and adjust the zero screw to achieve an output of 1.0 bar (15.0 psi).
9. Apply an input of 20 mA ( $V_m = 5.0$  V), and note the error (the actual reading versus 3.0 psi). Adjust the span screw to overcorrect the error by a factor of two. For example, if the reading was 2.95 psi, adjust the span screw to achieve an output of 3.05 psi.
10. Repeat steps 8 and 9 to verify and complete the calibration.

## Transporting the Module Final Assembly

The transducer allows the module final assembly to be removed while the housing is in its installed position. In the event the transducer does not function properly, an operational module final assembly can be taken to the field and exchanged with the nonfunctional module.

After the transducer is calibrated in the shop, the module final assembly can be removed from the housing. At the time the span and zero screws disengage, there will be minimal effect on the calibrated span. The calibrated module can now be taken to the field. Ensure that the span and zero potentiometers are not moved from their calibrated positions.

## Principle of Operation

The following paragraphs describe the functional parts of the 846. Figure 10 shows the block diagram.

Figure 10. Functional Parts Block Diagram

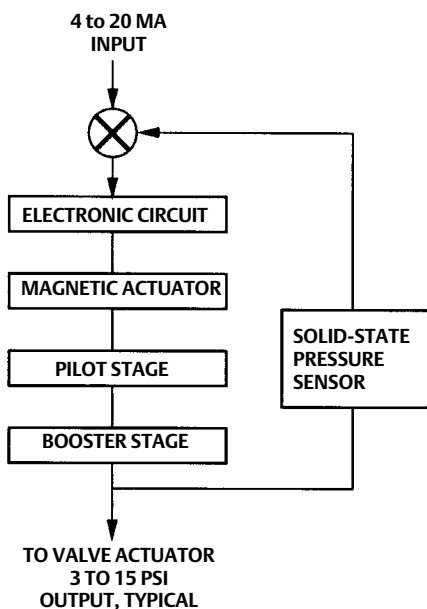

A6324-1

## Electronic Circuit

During operation, the input current signal is received by the transducer's electronic circuit and compared to the output pressure from the booster stage. A solid-state pressure sensor is part of the electronic circuit and monitors the booster stage output.

The sensor's pressure signal is fed to a simple internal control circuit. By using this technique, the transducer's performance is set by the sensor/circuit combination. Changes in output load (leaks), variations in supply pressure, or even component wear are sensed and corrected by the sensor/circuit combination. Electronic feedback allows crisp dynamic performance and readily compensates for output changes induced by vibration.

**Note**

Because the transducer is electronic in nature, it is not well-modeled in the loop as a simple resistor in series with an inductor. It is better thought of as a 50-ohm resistor in series with a 6.0 V voltage drop, with negligible inductance.

This is important when calculating the loop load. When the transducer is used in series with a microprocessor-based transmitter, the noninductive nature of the transducer allows digital signals to successfully pass through undistorted.

## Magnetic Actuator

The electronic circuit controls the level of current flowing through the actuator coil, which is located in the pilot/actuator assembly. A change to the level of coil current is made by the electronic circuit when it senses a discrepancy between the pressure measured by the sensor and the pressure required by the input signal.

The actuator performs the task of converting electrical energy (current) to motion. It uses a coaxial moving magnet design optimized for efficient operation and is highly damped at its mechanical resonance. A silicone rubber diaphragm helps to protect its working magnetic gaps from contamination.

## Pilot Stage

The pilot stage contains two opposed fixed nozzles: the supply nozzle and the receiver nozzle. It also contains the deflector, which is the moving element. See figures 11 and 12. The supply nozzle is connected to the supply air and provides a high-velocity air stream. The receiver nozzle captures the air stream and converts it back to pressure. The receiver nozzle pressure is the output pressure of the pilot stage.

Figure 11. Deflector/Nozzle Pilot Stage Operation (Direct Action)

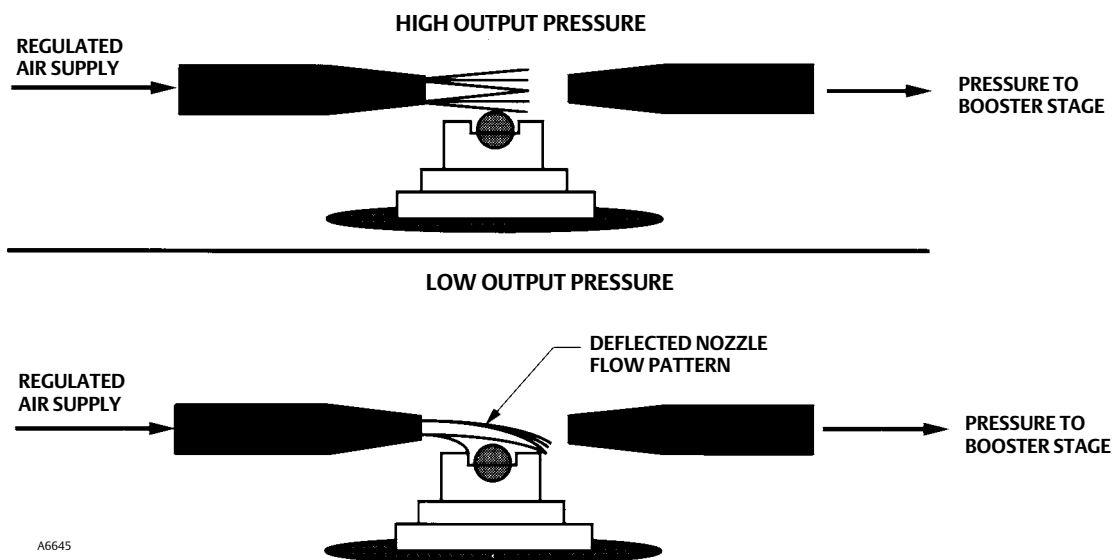

To vary the pilot output pressure, the high-velocity stream is diverted away from the receiver nozzle by the deflector, which is a cylindrical, aerodynamic body located between the two nozzles.

In response to a change in actuator coil current, the deflector is repositioned between the nozzles. There is a linear relationship between the coil current and the pilot stage output pressure. For direct action units, the power-off, or fail-safe, position of the top of the deflector is near the center of the stream and results in nearly zero pilot output pressure. As the coil is energized, the deflector is drawn out of the stream.

For reverse action units, the power-off, or fail-safe, position of the deflector is completely out of the stream. The result is maximum pilot output pressure. As the coil is energized, the deflector moves into the stream, resulting in a decreased pilot output pressure.

The deflector material is tungsten carbide, and the nozzles are 316 stainless steel. The nozzles have a large bore of 0.41 mm (0.016 inches), which provides good resistance to plugging.

Figure 12. Detail of Deflector/Nozzle Pilot Stage

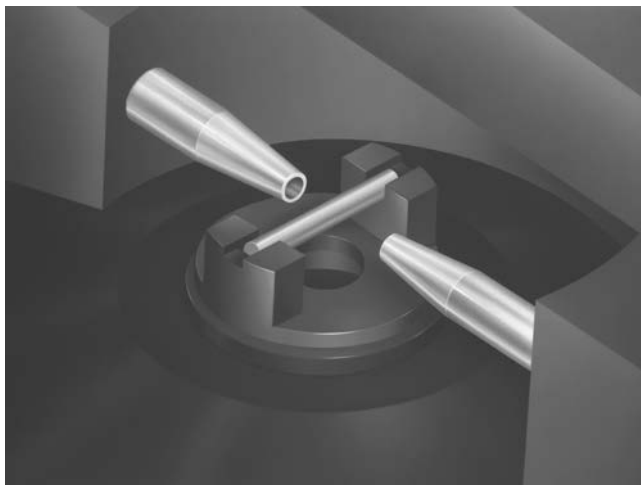

W6287

## Booster Stage

The receiver nozzle pressure controls the booster stage, which has a poppet valve design. An increase in receiver nozzle pressure positions the valving in the booster stage to produce an increase in the transducer output signal. A decrease in the receiver nozzle pressure positions the valving in the booster stage to allow exhaust to occur, decreasing the output signal.

The booster stage operates using a 3:1 pressure gain from the pilot stage. High flow rate capability is achieved by large flow area poppet design and internal porting having low flow resistance. The booster stage design provides very good stability in high vibration applications, and the poppet valve technology provides resistance to plugging.



## Troubleshooting

The modular design and unitized subassemblies of the 846 allows for quick and easy troubleshooting and repair. This section presents information on the diagnostic features and procedures for troubleshooting both models in service or in the shop.

### Diagnostic Features

If a control loop does not perform properly and the cause of malfunction has not been determined, two features of the transducer can be used to determine if the transducer is at fault: the stroke port and Remote Pressure Reading.

#### Stroke Port

The stroke port provides a way to quickly increase the transducer output, giving a rough measure of the unit's functionality. A hole in the module cover vents the constant bleed from the pilot stage. When the hole is covered, pressure at the pilot stage receiver nozzle increases, which in turn increases the output. Output pressure will increase to within 2 psi of supply pressure for either direct or reverse action. If output pressure does not increase to this level, it may indicate that supply air is not reaching the pilot stage or that a pilot stage nozzle is plugged.

---

#### Note

If the stroke port diagnostic feature is not desired, the transducer is available with an optional cover that contains multiple stroke ports, as shown in figure 4. This prevents increasing the output by covering the stroke port.

---

#### Remote Pressure Reading (RPR)

Remote Pressure Reading (RPR) is an optional diagnostic feature that enables the user to determine the output pressure from any location along the signal wire path. For loop troubleshooting, this allows the user to confirm the functionality of the transducer from a remote location.

A frequency signal directly proportional to the output pressure is superimposed on the input signal loop. The frequency range of the RPR function is 0 to 10,000 Hz.

A jumper on the circuit board activates the Remote Pressure Reading function. The Maintenance section provides instruction on positioning the jumper. The jumper, shown in figure 18, has two positions: N for ON, or D for OFF. The RPR jumper is in the N (ON) position when the unit ships from the factory, unless otherwise specified.

#### Using a Frequency Counter to Read the RPR Signal

A frequency counter can be used for Remote Pressure Reading. The frequency counter displays the RPR output frequency that can be converted to output pressure using a simple mathematical line formula as shown below. Figure 13 shows the wiring connections.

---

#### Notes

The Remote Pressure Reading (RPR) frequency signal has an amplitude of 0.4 to 1.0 V peak-to-peak. If other noise (frequency) with a comparable or greater amplitude is present on the line, it may make the RPR frequency signal unreadable.

The following procedure is applicable for 846 transducers manufactured starting March 2015. Contact your [Emerson sales office](#) for information on reading the RPR signal for products purchased prior to this date.

---

Equations

(1)  $P = m(f) + b$   
 P = pressure  
 f = frequency

(2)  $m = \frac{P_2 - P_1}{f_2 - f_1}$

Procedure

- 1) Find frequencies at zero and span pressure.
- 2) Solve for m, using equation (2).
- 3) Solve for b by inserting m, initial pressure, and initial frequency into equation (1).
- 4) Insert m and b into equation (1) to find conversion formula.

**Example**

- 1)  $P_1 = 3 \text{ psig}$       $f_1 = 6000 \text{ Hz}$   
 $P_2 = 15 \text{ psig}$       $f_2 = 9000 \text{ Hz}$
- 2)  $m = \frac{15 - 3}{9000 - 6000} = \frac{12}{3000}$
- 3)  $3 = \frac{12}{3000}(6000) + b$   
 $b = 3 - 24$   
 $b = -21$
- 4)  $P = \frac{12}{3000}(f) - 21$

Figure 13. Wiring Connections for Frequency Counter

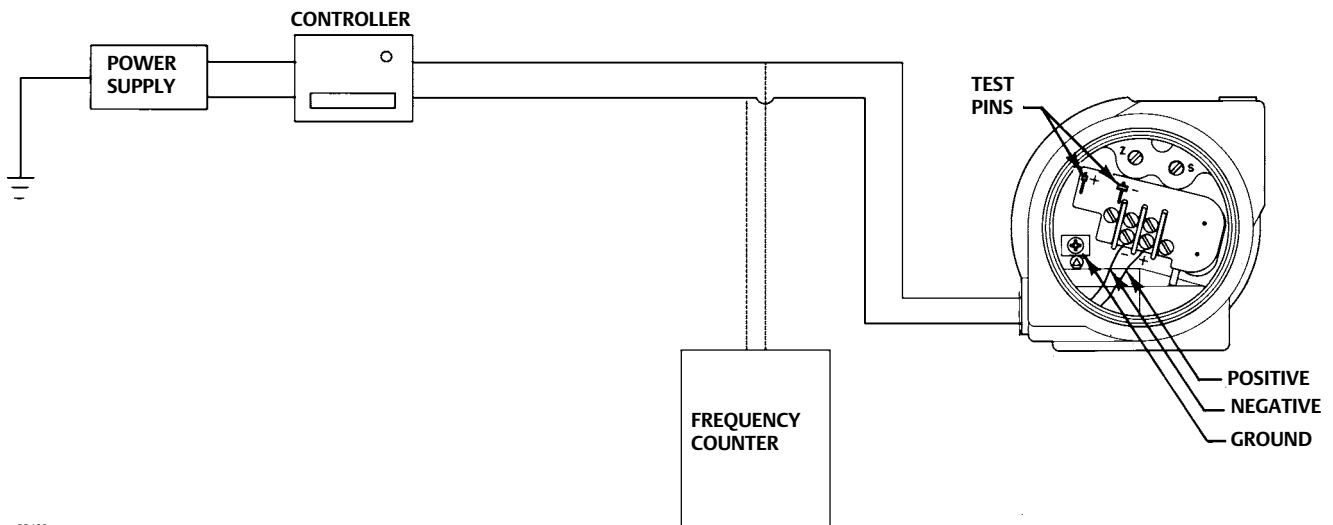

In-service Troubleshooting

A number of simple checks can be made on the transducer while the unit is in service. Figure 14 shows a troubleshooting flowchart.

1. Make sure that the module cover is tight. The cover should be hand-tightened and then advanced 1/4 to 1/2 turn (24 to 27 N•m) (18 to 20 lbf•ft).
2. Confirm the general functionality of the unit by using the diagnostic features described earlier in this section.



**⚠ WARNING**

Personal injury or property damage could result from an uncontrolled process. Before removing the module cover, ensure the process is properly controlled and the supply air to the transducer is turned off and vented. Unscrewing the module cover removes power from the electronics and opens the supply and output air passages to atmosphere resulting in an output signal of 0.0 psi.

---

**⚠ WARNING**

Personal injury or property damage could result from fire or an explosion. In explosive atmospheres, remove power and shut off the air supply to the transducer before attempting to remove the terminal compartment cover or module cover. Failure to do so could result in an electrical spark or explosion.

---

6. If applicable, remove the cover lock and screw to allow access to the terminal compartment cover.
7. Remove the terminal compartment cover (see Warning above), and use a milliammeter, or a digital voltmeter to confirm that proper input current is supplied to the transducer.
8. Remove the terminal compartment cover (see Warning above), and short the loop across the positive (+) and the negative (-) terminals to check the output. The output should be nearly 0 psi. If the output is not 0 psi, replace the module final assembly.
9. Remove the terminal compartment cover (see Warning above), and, using a digital voltmeter, check the voltage between the transducer positive (+) and negative (-) terminals. The voltage should measure 6.0 to 8.2 V. A lower voltage can indicate a short in the input wires or defective controller. No voltage can indicate an open circuit in the control loop. A voltage of greater than 8.5 volts indicates a problem with the transducer, a faulty or corroded connection at the transducer, or an overcurrent condition. Replace the module final assembly. If the voltage is still not in the proper range (6.0 to 8.2 V), remove the terminal block and terminal block connection board. Apply power to the electrical feedthroughs. (Note the polarity of the feedthroughs, shown in figure 21.) Recheck the voltage. If the voltage is in the proper range, replace the terminal block and terminal block connection board. If the voltage is still not in the proper range, replace the housing.
10. Prepare to remove the module final assembly from the housing, or to remove the transducer from its mounting bracket. Refer to Module Final Assembly in the Maintenance section for instructions on removing the module final assembly from the module housing.

**⚠ WARNING**

Personal injury or property damage could result from an uncontrolled process. Before removing the module cover, ensure the process is properly controlled and the supply air to the transducer is turned off and vented. Unscrewing the module cover removes power from the electronics and opens the supply and output air passages to atmosphere resulting in an output signal of 0.0 psi.

---

With the module final assembly removed from the housing, the following checks can be made.

1. Review the position of the Remote Pressure Reading jumper (if so equipped) and range jumper to confirm that they are placed in the desired position. Refer to Electronic Circuit Board in the Maintenance section, and figure 18 for the location of these jumpers and instructions on placement.
2. Observe the position and condition of the three module O-rings to confirm they make a tight seal.
3. Verify that the O-ring is correctly positioned in the groove on the flat face of the module cover. Refer to figure 21 for an exploded view.

4. Inspect the porting on the module final assembly to determine if large amounts of contaminants have entered the transducer.

Before making the following checks, disconnect both signal wires from the transducer, and ensure the module final assembly is removed from the housing.

1. Using an ohmmeter, check the electrical connections in the housing terminal compartment. The circuit should show an open between the positive (+) and negative (-) terminals. If not, replace the housing or terminal block and connection board.
2. Use a wire jumper to connect the two electrical feedthroughs located in the module compartment. The resistance between the positive (+) and negative (-) terminals in the terminal compartment should be 10 ohms. If not, check the electrical feedthroughs for short or open circuits. If a short or open circuit is found, replace the housing.
3. With the electrical feedthroughs jumpered as stated above, connect the ohmmeter to either the positive (+) or negative (-) terminal and the grounding lug. The circuit should show an open. If not, check for a short to the housing.
4. Remove the module from the module cover and inspect the pilot/actuator assembly for damage or clogging.

Some of the previous troubleshooting steps may be inconvenient to perform in the field. It may be best to make use of the modular design of the 846 and keep a spare, calibrated module final assembly available for exchange. If the module final assembly is to be transported to the shop for repair, first remove it from the module cover. Attach the spare module final assembly to the module cover. Refer to Module Final Assembly in the Maintenance section for complete instructions. The nonfunctioning module can then be returned to the shop for troubleshooting.

## Troubleshooting in the Shop

If the entire transducer is brought to the shop for troubleshooting, then the preceding sequence applies. If only the module final assembly has been brought to the shop, then use another 846 housing as a test fixture. Insert the module into the test fixture. Perform the previous steps (as they apply) of the In-service Troubleshooting procedure.

To further aid troubleshooting, the module final assembly can be broken down into three subassemblies. The troubleshooting sequence consists of exchanging the subassemblies with known working ones to determine which is at fault. The three subassemblies are the pilot/actuator assembly, the electronic circuit board, and the module subassembly. The module subassembly consists of the module final assembly with both the pilot/actuator assembly and electronic circuit board removed.

1. Remove the pilot/actuator assembly. Refer to Pilot/Actuator Assembly in the Maintenance section for complete removal information.

### **NOTICE**

**Do not apply force to the deflector bar while cleaning the nozzles. Doing so could alter the alignment or disable the deflector bar mechanism.**

### **NOTICE**

**Do not use chlorinated solvents for cleaning the pilot/actuator assembly. The chlorinated solvents will deteriorate the rubber diaphragm.**

- a. Inspect the nozzles and deflector. If they show a buildup of contaminants, clean the nozzles by gently inserting a wire with a maximum diameter of 0.38 mm (0.015 inches). Clean the deflector, if necessary, by spraying with contact cleaner.

- b. Make sure the O-rings are lightly lubricated with silicone grease and properly seated.
  - c. Reassemble and check operation.
  - d. If after cleaning, the transducer does not function, replace the pilot/actuator assembly with a new one.
  - e. Reassemble and check operation.
2. Remove the electronic circuit board from the module final assembly. The Maintenance section describes how to remove the board.
  - a. Inspect the O-rings around the sensor for damage and replace them if necessary.
  - b. Check the sensor port and areas around the sensor for foreign material, and clean if necessary.
  - c. Reassemble and check operation.
  - d. If the transducer does not function, replace the electronic circuit board with a new one. Refer to Electronic Circuit Board in the Maintenance section for complete removal information.
  - e. Reassemble and check operation.
3. The module subassembly is aligned at the factory and should not be further disassembled. If the above steps fail to produce a working unit, the module subassembly is faulty and should be replaced.

## Maintenance

This section describes the major components, assembly, and disassembly of 846 electro-pneumatic transducers.

### **⚠ WARNING**

To avoid personal injury or property damage from the sudden release of pressure or air:

- Always wear protective clothing, gloves, and eyewear when performing any maintenance operations.
- Disconnect any operating lines providing air pressure, electric power, or a control signal to the actuator. Be sure the actuator cannot suddenly open or close the valve.
- Use bypass valves or completely shut off the process to isolate the valve from process pressure. Relieve process pressure on both sides of the valve.
- Use lock-out procedures to be sure that the above measures stay in effect while you work on the equipment.
- Check with your process or safety engineer for any additional measures that must be taken to protect against process media.

### **⚠ WARNING**

The presence of Emerson personnel and approval agency personnel may be required if you service (other than normal, routine maintenance, such as calibration) or replace components on an 846 transducer that carries a third-party approval. When replacing components, use only components specified by the factory. Substitution with other components may void the third-party approval and result in personal injury or property damage.

Use only the procedures, and component replacement techniques specifically referenced in this manual. Unauthorized procedures and improper techniques can cause poor quality repairs, impair the safety features of the device, and affect product performance and the output signal used to control a process.

## Module Final Assembly

### **⚠ WARNING**

Refer to the Maintenance WARNINGS at the beginning of this section.

The active mechanical and electrical components of the transducer are incorporated into a single, field-replaceable module called the module final assembly, as shown in figure 15. Electrical connection between the terminal compartment and module final assembly is made by electrical feedthroughs that extend into the module compartment. The feedthroughs enter sockets on the electronic circuit board. The span and zero screws extend through the terminal compartment wall into the module compartment. Connection to the span and zero potentiometers on the electronic circuit board is made by hook and loop fasteners.

The module final assembly has three separate radial ports. The upper port is for supply air, the middle port for the output signal, and the lower ports for exhaust. Three O-rings separate the ports. The two lower O-rings are the same size, and the upper O-ring is slightly smaller. Table 4 shows O-ring sizes.

The module final assembly is attached to the module cover, which allows insertion and removal, and can be separated from the module cover for further disassembly. A module cover O-ring provides a seal between the module cover and module final assembly. Table 4 shows the O-ring sizes. A slip ring is located around the module feet. It allows the module cover to turn easily when the module final assembly is being removed from the housing.

The module final assembly consists of three major subassemblies, as shown in figure 15. They are the electronic circuit board, pilot/actuator assembly, and module subassembly.

Table 4. O-Ring Sizes

Description	Qty.	Size
Module O-rings	1	043
	2	042
Pilot/Actuator O-rings	2	006
Circuit Board O-rings	1	- - -
	1	005
Module Cover O-ring	1	238
Terminal Cover O-ring	1	238
Filter-Regulator O-ring	1	114



Figure 15. Fisher 846 Exploded View

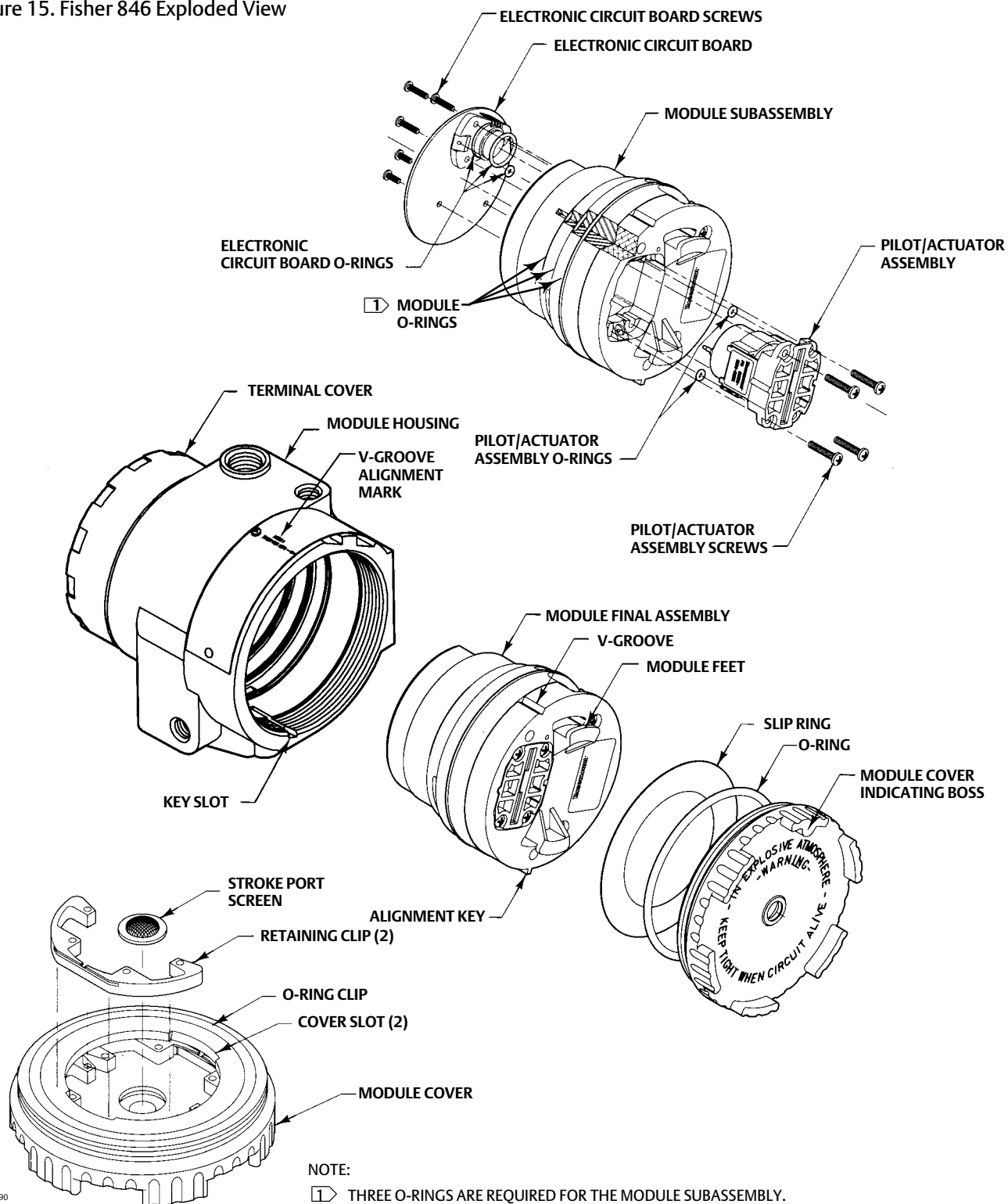

C0790

## Removing the Module Final Assembly

The module final assembly is attached to the module cover. Removing the module cover automatically removes the module final assembly from the housing. When the module cover is unscrewed, the electrical feedthroughs and span and zero adjustments automatically disengage. The internal air ports are also disengaged. The air supply to the transducer should be turned off to prevent uncontrolled air loss through the housing.

### **⚠ WARNING**

**Personal injury or property damage could result from an uncontrolled process. Perform the steps in the WARNING at the beginning of the Maintenance section before removing the module cover to ensure the process is properly controlled. Unscrewing the module cover removes power from the electronics and opens the supply and output air passages to atmosphere resulting in an output signal of 0.0 psi.**

### **⚠ WARNING**

**Personal injury or property damage could result from fire or an explosion. In explosive atmospheres, remove power and shut off the air supply to the transducer before attempting to remove the terminal compartment cover or module cover. Failure to do so could result in an electrical spark or explosion.**

Use the following steps to remove the module final assembly from the housing and module cover:

1. Shut off the air supply. If applicable, remove the cover lock and screw to allow access to the terminal compartment cover. Unscrew the module cover. When the module cover threads clear the housing, slowly pull on the cover, and the module final assembly will gradually come out of the housing.

#### **Note**

The module and the housing are designed for minimal clearance; therefore, patience may be required while pulling on the cover. Time must be allowed for release of the vacuum effect between the housing and module. If the module becomes tilted and cannot be removed, reinsert it completely into the housing and fully engage the module cover threads. Then proceed again with removal, ensuring that you pull slowly in a straight line.

Support both the module cover and the module final assembly as it comes out of the housing. This is to prevent dropping them, should they become detached accidentally.

### **⚠ CAUTION**

**Do not grip the module cover threads. The threads are sharp and may cause minor injury. Wear gloves when removing the module cover.**

2. Prepare to remove the module final assembly from the module cover. Align the module feet with the two interior cover slots. To accomplish this, identify the indicating boss on the module cover, shown in figure 16.

Grasp the module cover with one hand and the module final assembly with the other hand. Rotate the module final assembly so that the module alignment key is directly above the indicating boss on the module cover. Figure 16 shows the module alignment key and the indicating boss. The module feet are now aligned with the cover slots.

- Remove the module final assembly from the module cover. To accomplish this, hold the cover steady, and push the module final assembly in the direction of the module cover indicating boss. At the same time, lift the opposite foot of the module final assembly out of the cover slot, as shown in figure 17.

Figure 16. Alignment Key Above Module Cover Indicating Boss

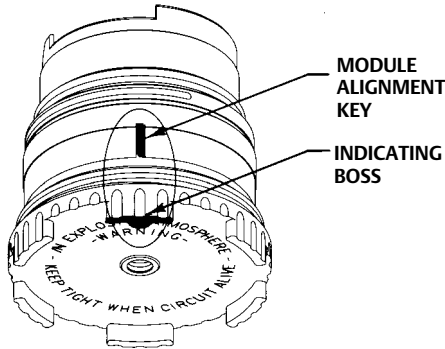
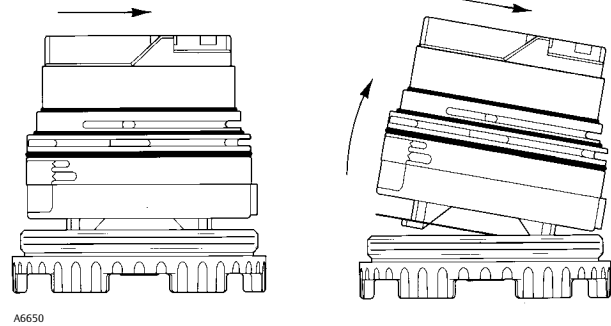

Figure 17. Removing the Module Final Assembly from the Module Cover



## Replacing the Module Final Assembly

Use the following procedure to attach the module cover and replace the module final assembly:

- Ensure that the electronic circuit board and the pilot actuator assembly provide the desired action (direct or reverse). See the Electronic Circuit Board and Pilot/actuator Assembly Action descriptions later in this section.
- Ensure that the slip ring is in place around the feet of the module final assembly. The module cover O-ring should be lightly lubricated with silicone grease and placed in the O-ring gland. The stroke port screen should be clean and in place.

### Note

The module cover O-ring must be in the O-ring gland, not down on the threads of the cover. This will ensure proper sealing of the pilot pressure area.

- Position the retaining clips in the module cover so they are ready to accept the feet of the module final assembly. Ensure the leaves on the retaining clips are facing up. Figure 15 shows the correct orientation.
- Insert one of the module feet into a cover slot, and push on the module final assembly to compress the retaining clip. Insert the opposite foot into the opposite cover slot, and rotate the module 90 degrees in the module cover to secure it in place.
- Ensure that the three module O-rings are in the O-ring glands and are lightly lubricated with silicone grease. Inspect the O-rings to ensure that they are not twisted or stretched.
- Apply lubricant to module cover threads for ease of assembly.
- Prepare to insert the module into the housing. Align the V-groove located on the module final assembly with the indicating mark located on the nameplate. This positions the alignment key with the key slot. Figure 15 shows the location of the V-groove and the indicating mark.
- Insert the module, engage the module cover threads, and screw on the module cover. The module final assembly will automatically engage the electrical feedthroughs and span and zero screws.

9. Hand tighten the module cover as much as possible. Use a wrench or long screwdriver shaft to tighten the module cover an additional 1/4 to 1/2 turn [24 to 27 N•m (18 to 20 lbf•ft)]. For units with ATEX/IECEX Flameproof approvals, make sure the cover lock and screw are securely re-installed. The screw accepts a 3 mm hex drive.

#### Note

When the module cover is tightened, connection is made with the electrical feedthroughs and span and zero screws, and the module final assembly O-rings become seated. Failure to fully tighten the module cover may prevent the transducer from operating properly.

## Electronic Circuit Board

### ⚠ WARNING

Refer to the Maintenance WARNINGS at the beginning of this section.

The electronic circuit board is located on top of the module final assembly, as shown in figure 15. Beneath the circuit board and permanently attached to it is the pressure sensor. Two jumpers on the circuit board control various functions of the transducer. Figure 18 shows the location of these jumpers.

Figure 18. Circuit Board Jumper Positions

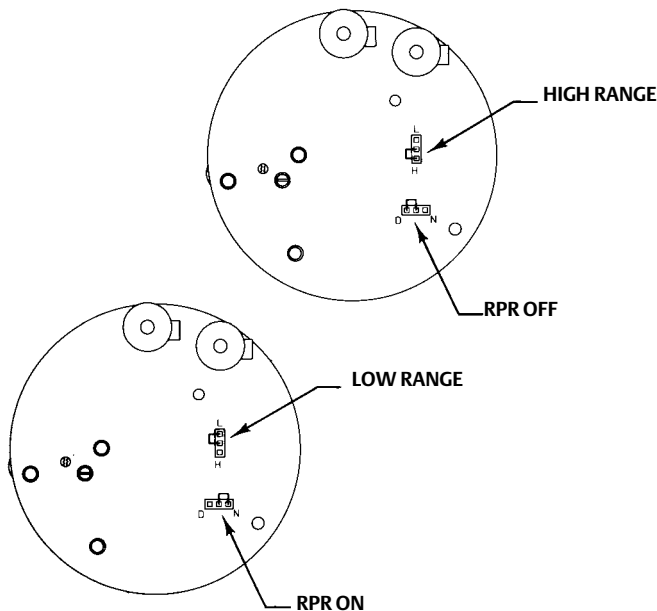

A6652

## Optional Remote Pressure Reading (RPR) Jumper

Remote Pressure Reading (RPR) is an optional diagnostic feature that enables the operator to determine the transducer output signal from any location along the signal wire path. The transducer generates a frequency signal

that can be received by a frequency counter. Operation of the RPR feature is jumper-selectable, in units so equipped. The RPR feature operates when the jumper is located in the N position on the circuit board. With the jumper in the D position, the RPR feature does not operate. When the RPR feature is included, the transducer is shipped with the RPR jumper in the N position, unless otherwise specified. For more information about the RPR feature, refer to Remote Pressure Reading (RPR) in the Troubleshooting section.

---

**Note**

When operating 846 transducers in series, only one unit may be configured for Remote Pressure Reading. Activating the RPR feature in two units will result in an unusable RPR signal.

---

## Range Jumper

The range jumper is positioned according to the calibration specified. All full span calibrations and some split range calibrations can be accomplished with the range jumper in the High Range position. Some split range calibrations require the jumper to be in the Low Range position. For more information about the range jumper, refer to Standard Performance: Split Range Input, Direct Action in the Principle of Operation section.

## Action

For direct action units, output changes directly with a corresponding change in input. For example, as the input increases from 4 to 20 mA, the output increases from 0.2 to 1.0 bar (3 to 15 psi). Direct action circuit boards are green in color.

For reverse action units, the output changes inversely with a change in input. For example, as the input increases from 4 to 20 mA the output decreases from 1.0 to 0.2 bar (15 to 3 psi). Reverse action circuit boards are blue in color.

Upon loss of input current, or if input current decreases below  $3.3 \pm 0.3$  mA, the output of the direct action unit decreases to less than 0.1 bar (1 psi). In the same situation, the output of the reverse action unit increases to near supply pressure.

## Removing the Electronic Circuit Board

The electronic circuit board is connected to the module final assembly by five mounting screws. The circuit board must be removed to inspect the pressure sensor located beneath it. To remove the circuit board, remove the five mounting screws and pull upward on the plastic board standoff (black=multirange; white=standard).

### **NOTICE**

**Standard electronic assembly handling procedures apply. Do not attempt to remove the circuit board by pulling on the components. Doing so could weaken the connections and disable the electronics.**

---

Be careful when handling the pressure sensor located beneath the circuit board. The pressure sensor lead frame is bent to allow the pressure sensor to fit properly in the sensor cavity of the module final assembly, and to maintain flush contact with the pressure sensor manifold.

Two O-rings are included with the pressure sensor. One O-ring is located on the pressure sensor. A second, smaller O-ring is positioned in the beveled O-ring gland of the module-assembly. Table 4 shows the O-ring sizes.

## Replacing the Electronic Circuit Board

1. Verify that the circuit board is green for assembly into a direct action unit, or blue for assembly into a reverse action unit.
2. Ensure that the two O-rings are in the proper position. The small O-ring is positioned in the beveled O-ring gland of the module subassembly. The sensor O-ring is positioned in the O-ring gland of the sensor. They should be lightly lubricated with silicone grease.
3. Position the circuit board on the module subassembly. Ensure that the circuit board mounting holes match those on the module subassembly. Place the three long screws in the mounting holes adjacent to the pressure sensor.
4. Place the two short screws in the remaining mounting holes. Tighten the three long screws first, then tighten the remaining two screws.

## Pilot/Actuator Assembly

### **⚠ WARNING**

Refer to the Maintenance WARNINGS at the beginning of this section.

The pilot/actuator assembly is located at the bottom of the module final assembly, as shown in figure 15. It is a unitized assembly consisting of the coil, magnet, and spring of the actuator, and the deflector and nozzles of the pilot stage. Two O-rings are part of the pilot/actuator assembly. Table 4 shows the O-ring sizes. They are located in the beveled O-ring glands of the module subassembly, adjacent to the nozzles. The pilot/actuator assembly is held in place by four mounting screws.

### Action

A blue rubber diaphragm under the deflector bar and nozzle area identifies the direct action pilot/actuator assembly. A red diaphragm under the nozzle area identifies the reverse action pilot/actuator assembly. Figure 19 shows the bottom view of the pilot/actuator assembly.

Figure 19. Pilot/Actuator Assembly (Bottom View)

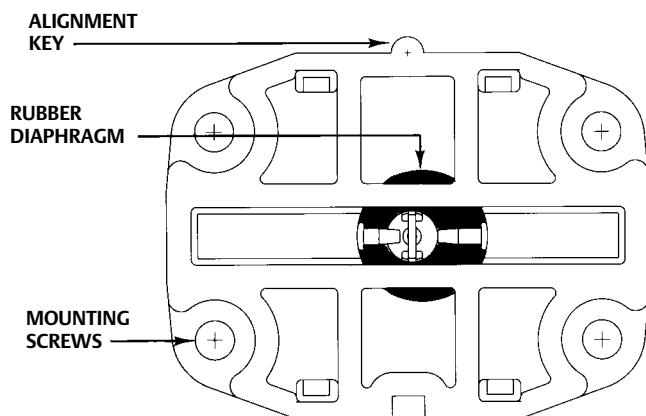

A6654

## Removing the Pilot/Actuator Assembly

To remove the pilot/actuator assembly, disengage the four mounting screws, and gently pull the assembly out of the module subassembly. To aid removal, the pilot/actuator framework may be gently gripped with a pair of pliers.

### NOTICE

**Do not attempt to remove the pilot/actuator assembly by gripping or pulling on the deflector or nozzles. Doing so could alter the alignment or disable the deflector/nozzle mechanism.**

Inspect the assembly for a buildup of foreign material. The nozzle passageways should be clear, and the deflector should be clean. The deflector can be cleaned by spraying it with contact cleaner. Clean the nozzles by gently inserting a wire with a maximum diameter of 0.38 mm (0.015 inches).

- Insert the wire into each nozzle separately from the outside as shown in figure 20.
- Do not try to put the wire through both nozzles simultaneously.
- Do not push the wire on the deflector bar.

### NOTICE

**Do not apply force to the deflector bar while cleaning the nozzles. Doing so could alter the alignment or disable the deflector mechanism.**

### NOTICE

**Do not use chlorinated solvents for cleaning the pilot/actuator assembly. The chlorinated solvents will deteriorate the rubber diaphragm**

Figure 20. Cleaning the Nozzles

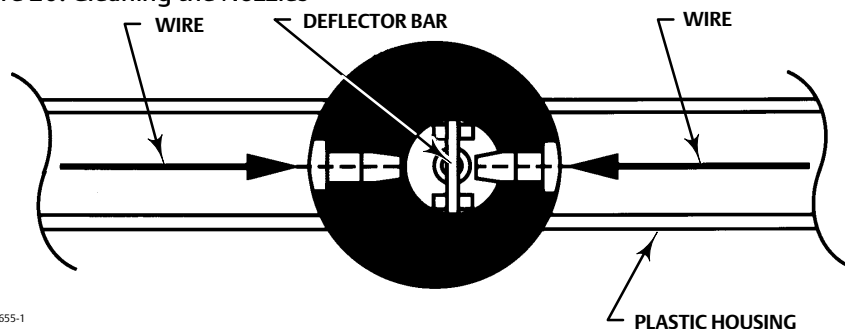

## Replacing the Pilot/Actuator Assembly

1. Verify that the rubber diaphragm under the nozzle area is blue for pilot/actuators inserted into a direct action unit, or red for pilot/actuators inserted into a reverse action unit.

2. Inspect the pilot/actuator assembly cavity in the module final assembly to ensure that it is clean.
3. Lightly lubricate the two O-rings with silicone grease, and place them in the beveled O-ring glands. O-rings between the pilot/actuator assembly and the module should be installed justified to the lower portion of the O-ring gland. When properly positioned, the air passageway should be visible through the O-ring inside diameter.
4. Prepare to insert the assembly by aligning the key on the pilot/actuator assembly with the key slot in the module subassembly.
5. Insert the assembly into the module subassembly, and engage the four mounting screws.

## Module Subassembly

### **⚠ WARNING**

Refer to the Maintenance WARNING at the beginning of this section.

The module subassembly, shown in figure 15, consists of the module final assembly with both the electronic circuit board and pilot/actuator assembly removed. The module subassembly contains the porting and valving for the booster stage.

### **Note**

The module subassembly is aligned at the factory and should not be further disassembled. Disassembling the module subassembly may result in performance outside specifications.

## Terminal Compartment

### **⚠ WARNING**

Refer to the Maintenance WARNING at the beginning of this section.

The terminal compartment contains the terminal block, terminal block connection board, span and zero screws, electrical feedthroughs, and internal grounding lug, as shown in figure 21. The terminal block connection board is attached to the terminal block and to the electrical feedthroughs.



Figure 21. Terminal Compartment Exploded View

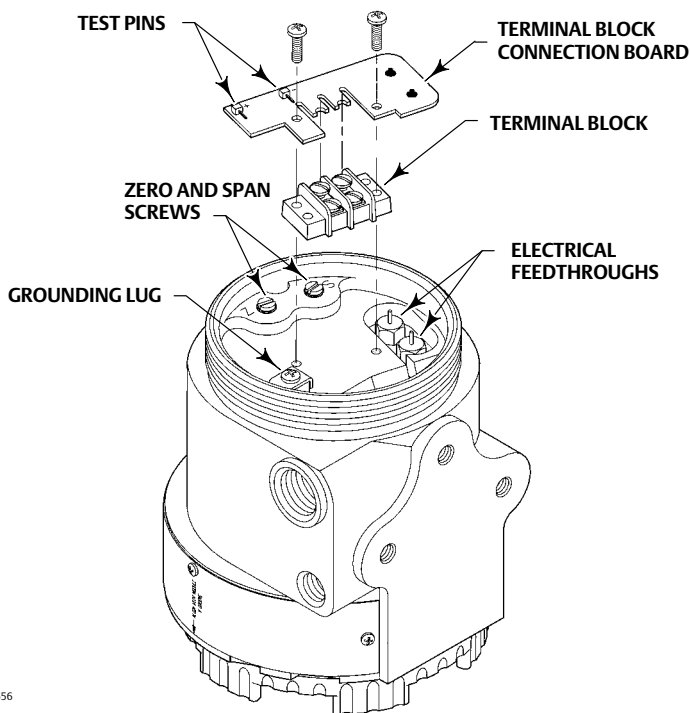

A6656

Separate test points are provided that have a 10-ohm resistor in series with the signal negative (-) terminal. The test points allow the input current to be determined with a voltmeter without disconnecting a signal lead. A 4 to 20 mA span produces a 40 to 200 mV DC voltage drop across the 10-ohm resistor. The test points can accommodate different connections, including alligator clips and E-Z hooks.

The terminal block and terminal block connection board can be removed by disengaging the two terminal block mounting screws. Lubricate the terminal compartment cover threads with anti-seizing paste or a low temperature lubricant. See table 4 for the size of the terminal compartment cover O-ring.

## Exhaust and Stroke Port Screens

### **⚠ WARNING**

Refer to the Maintenance WARNING at the beginning of this section.

Two identical screens, the exhaust port screen and the stroke port screen, allow air to vent to the outside environment. The exhaust port screen is located behind the nameplate. Removing the two nameplate screws and rotating the nameplate to the side allows access to the exhaust port screen. Figure 24 shows an exploded parts view.

The stroke port screen is located at the center of the module cover. Removing the module final assembly from the housing and then from the module cover allows access to the stroke port screen. Removing the Module Final Assembly earlier in this section describes this procedure. Figure 24 shows an exploded parts view.

## Parts

Whenever corresponding with your [Emerson sales office](#) about this equipment, always mention the transducer serial number.

### **⚠ WARNING**

**Use only genuine Fisher replacement parts. Components that are not supplied by Emerson should not, under any circumstances, be used in any Fisher instrument. Use of components not supplied by Emerson may void your warranty, might adversely affect the performance of the instrument, and could cause personal injury and property damage.**

## Parts Kit

Description	Part Number
Repair Kit [Kit includes O-rings (key 2, 5, 8, 9, 17) and slip ring (key 16)]	R846X000022
Module Assembly, Direct Action with RPR [Assembly includes Electronic Circuit Board Assembly (key 6), Module Subassembly (key 7), Pilot/Actuator Assembly (key 10) and associated O-rings.]	GE18543X022

## Parts List

### Note

Contact your Emerson sales office for Part Ordering information.

See table 5 and figure 24

Table 5. Parts List

Key No.	Description
1	Terminal Compartment Cover
2*	Terminal Compartment Cover O-ring
3	Housing
4	Terminal Block Assembly
5*	Electronic Circuit Board O-rings
6	Electronic Circuit Board Assembly
7	Module Subassembly
8*	Module O-rings
9*	Pilot/Actuator Assembly O-rings
10*	Pilot/Actuator Assembly
11	Pilot Actuator Assembly Screws
12	Nameplate Screws
13	Module Cover
14	Exhaust/Stroke Port Screen
15	Retaining Clip
16*	Slip Ring
17*	Module Cover O-ring
*	Supply Gauge (see figure 22) 0-60 psi/0-400 kPa/0-4 bar SST 0-60 psi/0-400 kPa/0-4 bar Output Gauge (see figure 23) 0-30 psi/0-200 kPa/0-2 bar B 0-60 psi/0-400 kPa/0-4 bar B SST 0-60 psi/0-400 kPa/0-4 bar

**Figure 22. Supply Gauge**

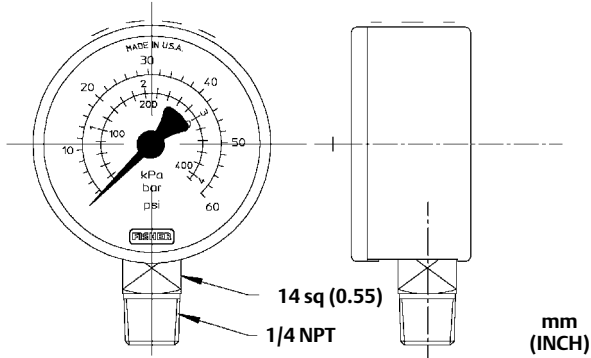

**Figure 23. Output Gauge**

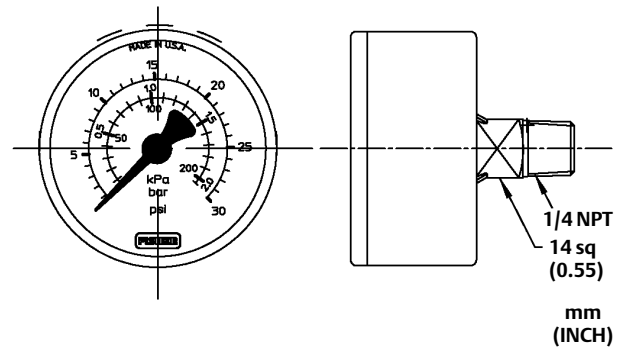

**Figure 24. Exploded Parts Drawing (also see table 5)**

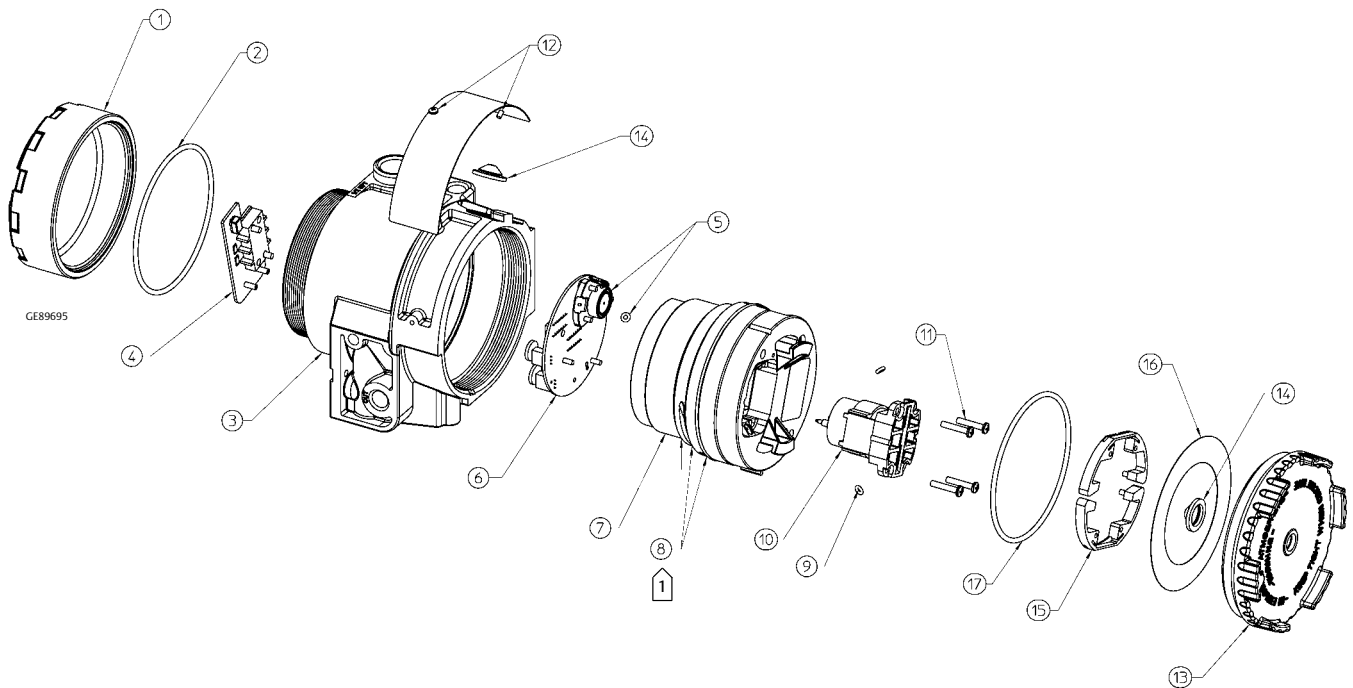

**NOTE:**

☐ THREE O-RINGS ARE REQUIRED FOR THE MODULE SUBASSEMBLY. THE UPPER O-RING IS SILICONE. THE LOWER TWO O-RINGS ARE NITRILE.

Neither Emerson, nor any of its affiliated entities assume responsibility for the selection, use, or maintenance of any product. Responsibility for proper selection, use, and maintenance of any product remains solely with the purchaser and end user.

Fisher is a mark owned by one of the companies in the Emerson business unit of Emerson Electric Co. Emerson and the Emerson logo are trademarks and service marks of Emerson Electric Co. All other marks are the property of their respective owners.

The contents of this publication are presented for informational purposes only, and while every effort has been made to ensure their accuracy, they are not to be construed as warranties or guarantees, express or implied, regarding the products or services described herein or their use or applicability. All sales are governed by our terms and conditions, which are available upon request. We reserve the right to modify or improve the designs or specifications of such products at any time without notice.

**Emerson**

Marshalltown, Iowa 50158 USA

Sorocaba, 18087 Brazil

Cernay, 68700 France

Dubai, United Arab Emirates

Singapore 128461 Singapore

[www.Fisher.com](http://www.Fisher.com)

---

