

Fisher™ NotchFlo™ DST Control Valve

Contents

Introduction	1
Scope of Manual	1
Description	1
Specifications	2
Educational Services	4
Installation	4
Maintenance	5
Packing Maintenance	8
Adding Packing Rings	9
Replacing Packing	10
Trim Removal	13
Valve Plug Maintenance	13
Lapping Seats	14
Trim Replacement	15
Parts Ordering	17
Parts Kits	17
Gasket Kits	19
Parts List	21

Figure 1. Fisher NotchFlo DST Control Valve



Introduction

Scope of Manual

This instruction manual includes installation, maintenance, and parts information for the Fisher NotchFlo DST control valve. Refer to separate manuals for instructions covering the actuator, positioner, and accessories.



Do not install, operate, or maintain NotchFlo DST valves without being fully trained and qualified in valve, actuator, and accessory installation, operation, and maintenance. To avoid personal injury or property damage, it is important to carefully read, understand, and follow all the contents of this manual, including all safety cautions and warnings. If you have any questions about these instructions, contact your [Emerson sales office](#) before proceeding.

Description

The NotchFlo DST globe (figure 1) and angle valves have metal seats, cage guiding, quick change trim, and push-down-to-close valve plug action. All available valve sizes and pressure ratings use balanced valve plugs with the exception of CL900 and CL1500 (NPS 1 and 1-1/2 valves) which use an unbalanced valve plug. To provide a seal between the cage and a balanced valve plug, the balanced valve plugs use a pressure-assisted spring-loaded seal ring.

A properly sized NotchFlo DST valve with 3-, 4-, or 6-stage dirty service anti-cavitation trim (figure 2) offers excellent control of high pressure drop liquids with entrained solids, while avoiding the damaging effects of cavitation and erosive solids.

Table 1. Specifications

<p>Available Valves</p> <p>CL600 3-Stage: Level C only CL900 and CL1500 ≤ NPS 4, 4-Stage: Levels A, B, and C⁽¹⁾ CL1500 ≥ NPS 6, 4-Stage: Level C only CL1500 6-Stage: Level C only CL2500 6-Stage: Level C only</p> <p>End Connection Styles and Ratings⁽²⁾</p> <p>Flanged: Consistent with CL600, 900, 1500, and 2500 per ASME B16.34</p> <p>Socket Welding: Consistent with CL600, 900, 1500, and 2500 per ASME B16.34</p> <p>Buttwelding: Consistent with CL600, 900, 1500, and 2500 per ASME B16.34</p> <p>Also see table 2</p>	<p>Shutoff Classification</p> <p>Class V: $[5 \times 10^{-12} \text{m}^3/\text{sec}/\text{bar}/\text{mm}$ of port diameter (0.0005 mL/min/psid/in) of water at service pressure drop] per ANSI/FCI 70-2 and IEC 60534-4</p> <p>Flow Characteristic</p> <p>Linear</p> <p>Flow Direction</p> <p>Flow up</p> <p>Approximate Weights</p> <p>See table 2</p>
---	--

1. Levels A, B, and C provide for varied pressure drops and capacity.

2. The pressure/temperature limits in this manual and any applicable standard or code limitation for valve should not be exceeded.

Figure 2. Fisher NotchFlo DST Trim



W8538-1

NotchFlo DST control valves utilize a high resistance, multi-stage, axial flow path (or passage) where fluid flow is parallel to the axis of the plug and cage.

Pressure reduction occurs throughout the length of the plug; thus individual stages aren't exposed to the full pressure differential. Therefore, trim life is enhanced.

NotchFlo DST trim utilizes a series of notched flow restrictions and expansions to control the pressure drop of the fluid. The amount of pressure drop per stage is controlled to prevent cavitation problems and minimize erosion issues.

Flow passage configuration provided by the multi-stage plug and cage design make the NotchFlo DST valves well-suited for applications involving fluids with entrained particles. This is a potentially serious problem for other anti-cavitation valve designs which are subject to clogged flow passages. Design of the trim allows for high rangeability.

Specifications

Specifications for NotchFlo DST valves are shown in table 1.

Table 2. Approximate Weights (Valve and Bonnet Assemblies)

VALVE DESIGN	VALVE SIZE, NPS	PRESSURE RATING	KILOGRAMS		POUNDS	
			Flanged	Socket Weld ⁽¹⁾ , Butt Weld, Screwed ⁽²⁾	Flanged	Socket Weld ⁽¹⁾ , Butt Weld, Screwed ⁽²⁾
3-Stage Angle Valves	1	CL600	20	---	44	---
	2		42	---	93	---
	3		86	---	190	---
	4		140	---	315	---
	6		300	---	660	---
	8		605	---	1340	---
3-Stage Globe Valves	1	CL600	20	15	45	35
	2		40	30	90	70
	3		70	50	155	110
	4		120	80	265	175
	6		275	230	610	510
	8		510	445	1130	980
4-Stage Angle Valves	1	CL900 and CL1500	50	40	110	90
	1-1/2		55	45	120	95
	2		95	95	210	210
	3		185	---	405	---
	4		285	---	625	---
	6		560	---	1230	---
4-Stage Cast Angle Valves	1	CL900 and CL1500	40	32	88	71
	1-1/2		43	35	95	77
	2		75	57	165	126
	3		148	118	326	260
	4		243	200	536	441
	6		523	443	1153	977
4-Stage Globe Valves	1	CL900 and CL1500	58	42	128	93
	1-1/2		75	48	165	106
	2		95	85	210	185
	3		185	140	405	310
	4		340	280	750	620

-continued-

Table 2. Approximate Weights (Valve and Bonnet Assemblies) (cont.)

VALVE DESIGN	VALVE SIZE, NPS	PRESSURE RATING	KILOGRAMS		POUNDS	
			Flanged	Socket Weld ⁽¹⁾ , Butt Weld, Screwed ⁽²⁾	Flanged	Socket Weld ⁽¹⁾ , Butt Weld, Screwed ⁽²⁾
6-Stage Angle Valves	1	CL2500	64	67	140	148
	2		180	170	405	375
	3		500	473	1110	1043
	4		465	433	1025	955
	6		1060	1030	2330	2271
6-Stage Cast Angle Valves	1	CL2500	50	42	110	93
	2		135	108	298	238
	3		352	293	776	646
	4		385	300	849	662
	6		921	692	2031	1526
6-Stage Globe Valves	1	CL1500	47	43	103	94
	2		98	84	217	186
	3		354	307	781	677
	4		406	386	896	852
	6		975	866	2149	1909
	1	CL2500	53	---	117	---
	2		130	---	287	---
	3		321	---	708	---
	4		427	---	942	---
	6		1026	---	2262	---

1. SWE available on NPS 1, 1-1/2, and 2 only.
 2. Screwed end available on NPS 1 and 2 CL600 only.

Educational Services

For information on available courses for Fisher NotchFlo DST valves, as well as a variety of other products, contact:

Emerson Automation Solutions
 Educational Services - Registration
 Phone: 1-641-754-3771 or 1-800-338-8158
 E-mail: education@emerson.com
 emerson.com/fishervalvetraining

Installation

⚠ WARNING

Always wear protective gloves, clothing, and eyewear when performing any installation operations to avoid personal injury.

Personal injury or property damage caused by sudden release of pressure may result if the valve assembly is installed where service conditions could exceed the limits given in table 1 or on the appropriate nameplates. To avoid such injury or damage, provide a relief valve for over-pressure protection as required by government or accepted industry codes and good engineering practices.

Check with your process or safety engineer for any additional measures that must be taken to protect against process media.

If installing into an existing application, also refer to the WARNING at the beginning of the Maintenance section in this instruction manual.

⚠ WARNING

Some bonnet flanges have a tapped hole that was used to handle the bonnet during manufacture. Since this tapped hole was not designed or intended to support the weight of the valve/bonnet assembly, do not use this tapped hole to lift the valve assembly or personal injury may result from the assembly falling.

CAUTION

When ordered, the valve configuration and construction materials were selected to meet particular pressure, temperature, pressure drop, and controlled fluid conditions. Since some body/trim material combinations are limited in their pressure drop and temperature ranges, do not apply any other conditions to the valve without first checking with your [Emerson sales office](#).

1. Before installing the valve, inspect it to ensure that the valve body cavity is free of foreign material.
2. Clean out all pipelines to remove scale, welding slag, and other foreign materials before installing the valve.
3. Flow through the valve must be in the direction indicated by the flow arrow, which is cast on or attached to the valve body.
4. Use accepted piping practices when installing the valve in the pipeline. For flanged valve bodies, use a suitable gasket between the body and pipeline flanges.
5. Install a three-valve bypass around the valve if continuous operation is required during maintenance.
6. If the actuator and valve body are shipped separately, refer to the actuator mounting procedure in the appropriate actuator instruction manual.
7. If the valve body was shipped without packing installed in the packing box, install the packing before putting the valve body into service. Refer to instructions given in the Packing Maintenance procedure.

⚠ WARNING

Personal injury could result from packing leakage. Valve packing was tightened prior to shipment; however, the packing might require some readjustment to meet specific service conditions. Check with your process or safety engineer for any additional measures that must be taken to protect against process media.

Maintenance

Refer to figure 10 through 19.

Valve parts are subject to normal wear and must be inspected and replaced as necessary. Inspection and maintenance frequency depends on the severity of service conditions. This section includes instructions for packing maintenance and trim maintenance. All maintenance operations may be performed with the valve in the line.

⚠ WARNING

Avoid personal injury or damage to property from sudden release of pressure or uncontrolled process fluid. Before starting disassembly:

- Do not remove the actuator from the valve while the valve is still pressurized.
- Always wear protective gloves, clothing, and eyewear when performing any maintenance operations to avoid personal injury.

- Disconnect any operating lines providing air pressure, electric power, or a control signal to the actuator. Be sure the actuator cannot suddenly open or close the valve.
- Use bypass valves or completely shut off the process to isolate the valve from process pressure. Relieve process pressure on both sides of the valve. Drain the process media from both sides of the valve.
- Vent the power actuator loading pressure and relieve any actuator spring precompression.
- Use lock-out procedures to be sure that the above measures stay in effect while you work on the equipment.
- The valve packing box may contain process fluids that are pressurized, *even when the valve has been removed from the pipeline*. Process fluids may spray out under pressure when removing the packing hardware or packing rings, or when loosening the packing box pipe plug.
- Check with your process or safety engineer for any additional measures that must be taken to protect against process media.

Figure 3. PTFE V-Ring Packing Arrangements for Plain and Extension Bonnets

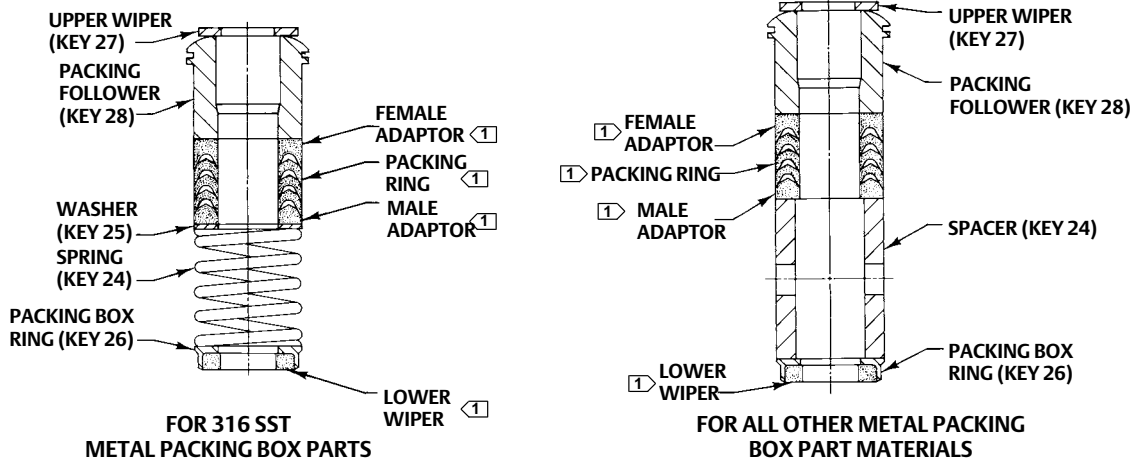

NOTE:
 (1) MALE ADAPTOR, PACKING RING, FEMALE ADAPTOR,
 AND LOWER WIPER ARE PART OF PACKING SET (KEY 22).
 2 REQ'D FOR DOUBLE ARRANGEMENTS, EXCEPT LOWER WIPER.

SINGLE ARRANGEMENTS

12A7837-A
 B1429-5

Figure 4. Detail of Graphite Ribbon/Filament Packing for Plain and Extension Bonnets

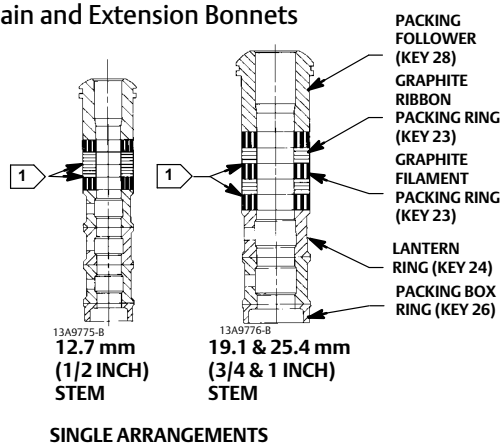

NOTE:
 1 0.102 mm (0.004 INCH) THICK SACRIFICIAL ZINC WASHERS;
 USE ONLY ONE BELOW EACH GRAPHITE RIBBON RING.

Figure 5. Detail of Graphite ULF Packing for Plain Bonnets

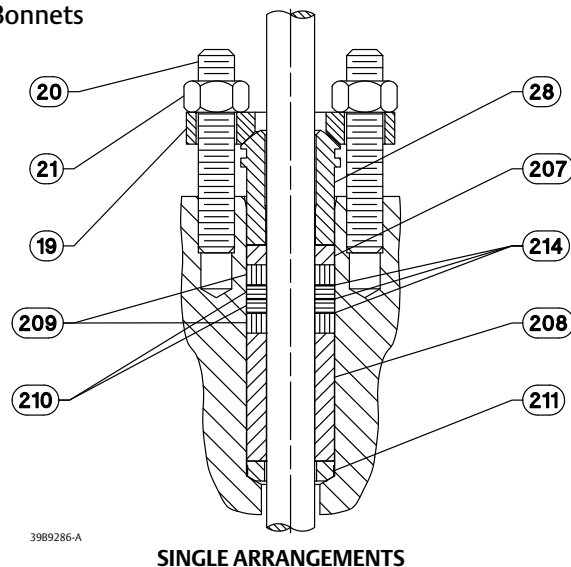

Table 3. CL600 Recommended Torque for Packing Flange Nuts (non live-loaded)

VALVE STEM DIAMETER		PRESSURE RATING	GRAPHITE TYPE PACKING				PTFE TYPE PACKING			
			Minimum Torque		Maximum Torque		Minimum Torque		Maximum Torque	
mm	Inches		N•m	Lbf•in	N•m	Lbf•in	N•m	Lbf•in	N•m	Lbf•in
12.7	1/2	CL600	9	81	14	122	4	39	7	58
19.1	3/4	CL600	21	182	31	274	10	87	15	131
25.4	1	CL600	35	310	53	466	17	149	25	223

Table 4. CL900, 1500, and 2500 Recommended Torque for Packing Flange Nuts (non live-loaded)

VALVE STEM DIAMETER		PRESSURE RATING	TORQUE			
			N•m		lbf•ft	
mm	Inches		Min	Max	Min	Max
12.7	1/2	CL900	12	18	9	13
		CL1500	15	22	11	16
		CL2500	18	24	13	18
19.1	3/4	CL900	27	41	20	30
		CL1500	34	50	25	37
		CL2500	41	61	30	45
25.4	1	CL900	42	62	31	46
		CL1500	52	77	38	57
		CL2500	61	91	45	67
31.8	1-1/4	CL900	56	83	41	61
		CL1500	68	102	50	75

CAUTION

The NotchFlo DST valve uses spiral-wound gaskets which are crushed to provide their seal. A spiral-wound gasket should never be reused. Whenever a gasket seal is disturbed by removing or shifting gasketed parts, a new gasket must be installed upon reassembly. This is necessary to ensure a good gasket seal, since the used gasket will not seal properly.

The spiral-wound gaskets are of special design. Failure to use genuine Fisher replacement parts may result in valve damage and/or failure.

Packing Maintenance

Key numbers refer to figure 3 for PTFE V-ring packing and to figure 4 and 5 for graphite ribbon/filament and graphite ULF packing, unless otherwise indicated.

⚠ WARNING

To avoid personal injury or equipment damage resulting from packing leakage, inspect the valve plug stem and packing box wall for nicks or scratches while performing the following procedures.

Use care to avoid damaging these surfaces.

For spring-loaded single PTFE V-ring packing, the spring (key 24) maintains a sealing force on the packing. If leakage is noted around the packing follower (key 28), check to be sure the shoulder on the packing follower is touching the bonnet. If the shoulder is not touching the bonnet, tighten the packing flange nuts (key 21, figure 10 through 19) until the shoulder is against the bonnet. If leakage cannot be stopped in this manner, proceed to the Replacing Packing procedure.

Table 5. Torque for Body-to-Bonnet Bolting Using Anti-Seize Lubricant for CL600 Fisher NotchFlo DST Valves

VALVE RATING	VALVE SIZE, NPS	BOLT TORQUES ^(1,4)			
		SA193-B7, SA193-B8M Class 2 ⁽³⁾		SA193-B8M Class 1 ⁽²⁾	
		N•m	Lbf•ft	N•m	Lbf•ft
CL600	1	122	90	61	45
	2	91	67	43	32
	3	163	120	84	62
	4	258	190	149	110
	6	712	525	---	---
	8	522	385	---	---

1. Determined from laboratory tests.
 2. SA193-B8M annealed.
 3. SA193-B8M strain hardened.
 4. For other materials and torques contact your [Emerson sales office](#).

Table 6. Torque for Body-to-Bonnet Bolting Using Anti-Seize Lubricant for CL900 and CL1500, Fisher NotchFlo DST Valves

VALVE RATING	TRIM	VALVE SIZE, NPS	BOLT TORQUES ^(1,4)			
			SA193-B7, SA193-B8M Class 2 ⁽³⁾		SA193-B8M Class 1 ⁽²⁾	
			N•m	Lbf•ft	N•m	Lbf•ft
CL900 & 1500	4-stage	1 or 1-1/2	258	190	149	110
		2	373	275	237	175
		3	712	525	509	375
		4	942	695	705	520
		6	2671	1970	---	---
		8	2671	1970	---	---
CL1500	6-stage	1	258	190	149	110
		2	373	275	237	175
		3	2129	1570	---	---
		4	2671	1970	---	---
		6	2671	1970	---	---

1. Determined from laboratory tests.
 2. SA193-B8M annealed.
 3. SA193-B8M strain hardened.
 4. For other materials and torques contact your [Emerson sales office](#).

Table 7. Torque for Body-to-Bonnet Bolting Using Anti-Seize Lubricant for CL2500 Fisher NotchFlo DST Valves

VALVE RATING	VALVE SIZE	BOLT TORQUES ^(1,2)	
		SA193-B7, SA193-B7M	
		N•m	lbf•ft
CL2500	1	373	275
	2	712	525
	3	2129	1570
	4	2671	1970
	6	2671	1970

1. Determined from laboratory tests.
2. For other materials and torques contact your Emerson sales office.

Table 8. Valve Stem Connection Torque and Hole Size for Pin

VALVE STEM DIAMETER		TORQUE, MINIMUM TO MAXIMUM		HOLE SIZE	
mm	Inches	N•m	Lbf•ft	mm	Inch
12.7	1/2	81-115	60-85	3.20 - 3.25	0.126 - 0.128
19.1	3/4	237-339	175-250	4.80 - 4.88	0.189 - 0.192
25.4	1	420-481	310-355	6.38 - 6.45	0.251 - 0.254
31.8	1-1/4	827-908	610-670	6.38 - 6.45	0.251 - 0.254

If there is undesirable packing leakage with other than spring-loaded PTFE V-ring packing, first try to limit the leakage and establish a stem seal by tightening the packing flange nuts (key 21, figure 10 through 19) to at least the minimum recommended torque in table 3 or 4. However, do not exceed the maximum recommended torque in table 3 or 4. or excessive friction may result. If leakage continues, replace the packing by following the numbered steps presented in the Replacing Packing procedure.

If the packing is relatively new and tight on the valve plug stem, and if tightening the packing flange nuts does not stop the leakage, it is possible that the stem is worn or nicked so that a seal cannot be made. The surface finish of a new stem is critical for making a good packing seal. If the leakage comes from the outside diameter of the packing, it is possible that the leakage is caused by nicks or scratches around the packing box wall. While replacing the packing according to the Replacing Packing procedure, inspect the valve plug stem and packing box wall for nicks or scratches.

Adding Packing Rings

⚠ WARNING

Refer to the **WARNING** at the beginning of the Maintenance section in this instruction manual.

To avoid personal injury or equipment damage resulting from packing leakage, inspect the valve plug stem and packing box wall for nicks or scratches while performing the following procedures. Use care to avoid damaging these surfaces.

Key numbers referred to in this procedure are shown in figures 10 through 19, unless otherwise indicated.

When using packing with a lantern ring (key 24) it may be possible to add packing rings above the lantern ring as a temporary measure without removing the actuator from the valve body.

1. Isolate the control valve from the line pressure, release pressure from both sides of the valve body, and drain the process media from both sides of the valve. If using a power actuator, also shut-off all pressure lines to the power actuator, release all pressure from the actuator. Use lock-out procedures to be sure that the above measures stay in effect while you work on the equipment.
2. Remove the packing flange nuts (key 21) and lift the packing flange, upper wiper, and packing follower (keys 19, 27, and 28) away from the valve body.
3. It may be possible to dig out the old packing rings on top of the lantern ring, but use care to avoid scratching the valve plug stem or packing box wall. Clean all metal parts to remove particles that would prevent the packing from sealing.

4. Remove the stem connector and slip the packing rings over the end of the valve plug stem.
5. Reassemble the packing follower, upper wiper, packing flange, and packing flange nuts (keys 28, 27, 19, and 21).
6. Reconnect the body-actuator stem connection according to the appropriate actuator instruction manual.
7. Tighten the packing flange nuts only far enough to stop leakage under operating conditions. Check for leakage around the packing follower when the valve is being put into service. Retighten the packing flange nuts as required (see table 3 or 4).

Replacing Packing

⚠ WARNING

Refer to the **WARNING** at the beginning of the Maintenance section in this instruction manual.

To avoid personal injury or equipment damage resulting from packing leakage, inspect the valve plug stem and packing box wall for nicks or scratches while performing the following procedures. Use care to avoid damaging these surfaces.

Key numbers referred to in this procedure are shown in figures 10 through 19, unless otherwise indicated.

1. Isolate the control valve from the line pressure, release pressure from both sides of the valve body, and drain the process media from both sides of the valve. If using a power actuator, also shut-off all pressure lines to the power actuator, release all pressure from the actuator. Use lock-out procedures to be sure that the above measures stay in effect while you work on the equipment.
2. Remove the cap screws in the stem connector, and separate the two halves of the stem connector. Then exhaust all actuator pressure, if any was applied, and disconnect the actuator supply and any leakoff piping.
3. Remove either the yoke locknut (key 32) or the hex nuts (key 30), and remove the actuator from the bonnet (key 18).
4. Loosen the packing flange nuts (key 21) so that the packing (keys 22, 23, 209, or 210, figures 3, 4, or 5) is not tight on the valve plug stem (key 6). Remove any travel indicator disk and stem locknuts from the valve plug stem threads.

CAUTION

When lifting the bonnet (key 18), be sure that the valve plug and stem assembly (keys 5 and 6) remains on the seat ring (key 4). This avoids damage to the seating surfaces as a result of the assembly dropping from the bonnet after being lifted part way out. The parts are also easier to handle separately.

Use care to avoid damaging gasket sealing surfaces.

⚠ WARNING

To avoid personal injury or property damage caused by uncontrolled movement of the bonnet, loosen the bonnet by following the instructions in the next step. Do not remove a stuck bonnet by pulling on it with equipment that can stretch or store energy in any other manner. The sudden release of stored energy can cause uncontrolled movement of the bonnet. If the cage sticks to the bonnet, proceed carefully with bonnet removal and support the cage so that it will not fall unexpectedly from the bonnet.

Note

The following step also provides additional assurance that the valve body fluid pressure has been relieved.

5. Hex nuts (key 14) attach the bonnet to the valve body. Loosen these nuts approximately 3 mm (1/8 inch). Then loosen the body-to-bonnet gasketed joint by either rocking the bonnet or prying between the bonnet and valve body. Work the prying tool around the bonnet until the bonnet loosens. If no fluid leaks from the joint, proceed to the next step. If fluid leaks from the joint, the process pressure was not relieved from the valve as noted in the Warning at the beginning of the Maintenance section in this manual.
6. Unscrew the hex nuts (key 14) and carefully lift the bonnet off the valve stem. If the valve plug and stem assembly starts to lift with the bonnet, use a brass or lead hammer on the end of the stem and tap it back down. Set the bonnet on a cardboard or wooden surface to prevent damage to the bonnet gasket surface.
7. Remove the valve plug (key 5), bonnet gasket (key 11), cage (key 2), cage gaskets (if applicable) (key 65), seat ring (key 4), and the seat ring gasket(s) (key 12).

CAUTION

Inspect the seat ring, cage, bonnet, and body gasket surfaces. These surfaces must be in good condition, with all foreign material removed. Small burrs less than approximately 0.076 mm (0.003 inch) in height (the thickness of a human hair) can be ignored. Scratches or burrs that run across the serrations are not permitted under any conditions, because they will prevent the gaskets from sealing properly.

8. Clean all gasket surfaces with a good wire brush. Clean in the same direction as the surface serrations, not across them.
9. Cover the opening in the valve body to protect the gasket surface and to prevent foreign material from getting into the valve body cavity.
10. Remove the packing flange nuts (key 21), packing flange (key 19), upper wiper (key 27), and packing follower (key 28). Carefully push out all the remaining packing parts from the valve side of the bonnet using a rounded rod or other tool that will not scratch the packing box wall.
11. Clean the packing box and the following metal packing parts: packing follower, packing box ring (key 26), spring or lantern ring (key 24), and, for single arrangements of PTFE V-ring packing only, special washer (key 25).
12. Inspect the valve stem threads for any sharp edges that might cut the packing. A whetstone or emery cloth may be used to smooth the threads if necessary.
13. Remove the protective covering from the valve body cavity, and install the seat ring and cage using new seat ring gasket(s) (key 12), bonnet gasket (key 11), and cage gaskets (if applicable) (key 65). Install the plug, then slide the bonnet over the stem and onto the studs (key 13).

Figure 6. Installing Graphite Ribbon/Filament Packing Rings One at a Time

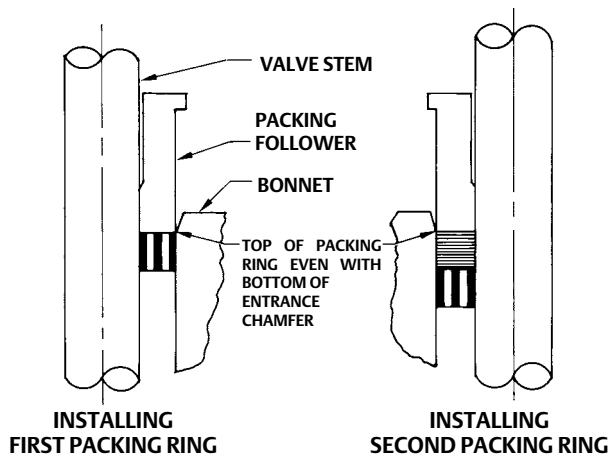

A2207-2

Note

The prelubricated hex nuts (key 14) referred to in step 14 can be identified by a black film coating on the nut threads.

The proper bolting procedures in step 14 include--but are not limited to--ensuring that the bonnet stud threads are clean, and that the hex nuts are evenly tightened to the specified torque values.

CAUTION

Failure to comply with good bonnet-to-body bolting practices and the torque values shown in tables 5, 6, and 7 may result in damage to the valve. Cheater bars or slug wrenches should not be used for this procedure.

Hot torquing is not recommended on CL900, CL1500, and CL2500 valves. When operating temperature has been reached, perform this torquing procedure once again on CL600 valves.

Note

Stud(s) and nut(s) should be installed such that the manufacturer's trademark and material grade marking is visible, allowing easy comparison to the materials selected and documented in the Emerson/Fisher serial card provided with this product.

▲ WARNING

Personal injury or damage to equipment could occur if improper stud and nut materials or parts are used. Do not operate or assemble this product with stud(s) and nut(s) that are not approved by Emerson/Fisher engineering and/or listed on the serial card provided with this product. Use of unapproved materials and parts could lead to stresses exceeding the design or code limits intended for this particular service. Install studs with the material grade and manufacturer's identification mark visible. Contact your Emerson representative immediately if a discrepancy between actual parts and approved parts is suspected.

14. Lubricate the stud threads and the faces of the hex nuts (key 14) with anti-seize lubricant (not necessary if new factory prelubricated hex nuts are used). Install the hex nuts and tighten them finger-tight. Stroke the valve several times to center the trim. Torque the nuts in a crisscross pattern to no more than 1/4 of the nominal torque value specified in tables 5, 6, and 7.

When all nuts are tightened to that torque value, increase the torque by 1/4 of the specified nominal torque and repeat the crisscross pattern. Repeat this procedure until all nuts are tightened to the specified nominal value. Apply the final torque value again and, if any nut still turns, tighten every nut again.

Note

When installing packing rings, prevent entrapping air between the rings. Add the rings one at a time without forcing them below the chamfer of the packing box entrance chamber. As each successive ring is added, the stack should not be pushed down more than the thickness of the added ring (figure 6).

15. Install new packing and the metal packing box parts according to the appropriate arrangement in figures 3, 4, or 5. If desired, packing parts may be pre-lubricated with a silicon base grease for easier installation. Slip a smooth-edged pipe over the valve stem, and gently tap each soft packing part into the packing box, being sure that air is not trapped between adjacent soft parts.

16. Slide the packing follower, wiper, and packing flange into position. Lubricate the packing flange studs (key 20) and the faces of the packing flange nuts (key 21). Install the packing flange nuts.

For the spring-loaded PTFE V-ring packing shown in figure 3, tighten the packing flange nuts until the shoulder on the packing follower (key 28) contacts the bonnet.

Note

Lubrication is not recommended on graphite packing.

For **graphite packing**, tighten the packing flange nuts to the maximum recommended torque shown in table 3 or 4. Then, loosen the packing flange nuts, and retighten them to the recommended minimum torque shown in table 3 or 4.

For **other packing types**, tighten the packing flange nuts alternately in small equal increments until one of the nuts reaches the minimum recommended torque shown in table 3 or 4. Then, tighten the remaining flange nuts until the packing flange is level and at a 90-degree angle to the valve stem.

17. Mount the actuator on the valve body assembly, and reconnect the actuator and valve plug stems according to the procedures in the appropriate actuator instruction manual.

Trim Removal

Key numbers referenced in this procedure are shown in figures 10 through 19, except where indicated.

1. Remove the actuator and bonnet by following steps 1 through 6 of the replacing packing procedure. Observe all warnings and cautions in that procedure.
2. Lift the valve stem and attached valve plug out of the valve body. If the valve plug is to be reused, tape or otherwise protect the valve plug stem and the valve plug seating surface to prevent scratches.
3. Lift out the cage (key 2), the bonnet gasket (key 11), and (if applicable) the cage gaskets (key 65).
4. Remove the seat ring (key 4) and the seat ring gasket(s) (key 12).
5. Inspect the parts for wear or damage and replace if needed.
6. Refer to the Valve Plug Maintenance procedure or to the Lapping Seats procedure.

Valve Plug Maintenance

Key numbers used in this procedure are shown in figures 10 through 19, except where indicated.

1. With the valve plug (key 5) removed according to the trim removal procedure, proceed as appropriate:

For the NPS 1 and 1-1/2 CL900 or 1500 and NPS 1 CL2500 NotchFlo DST valves, proceed to step 2.

For all other NotchFlo DST valves, work the retaining ring (key 10) off the valve plug with a screwdriver. Carefully slide the backup ring, seal ring, and anti-extrusion rings (keys 9, 8, and 63) off the valve plug.

2. To replace the valve plug stem (key 6), drive out the pin (key 7), and unscrew the stem from the valve plug.

CAUTION

Never reuse an old stem with a new valve plug. Using an old stem with a new plug requires drilling a new pin hole in the stem. This weakens the stem and may cause the stem to fail in service. If a new valve plug is required, always order a valve plug, stem, and pin as an assembly. Specify the correct part number of each of the three parts, but state that the parts are being ordered as an assembly.

A used valve plug may be reused with a new stem.

3. Thread the new stem into the valve plug and tighten it to the appropriate torque value given in table 8. Using the valve plug pin hole as a guide, drill the pin hole through the stem. Refer to table 8 for drill sizes.
4. Drive in the pin to lock the assembly.
5. If it is necessary to lap the seating surfaces, complete the lapping seats procedure before installing the seal ring. The Trim Replacement procedure provides seal ring installation instructions and valve reassembly instructions.

Lapping Seats

Key numbers referenced in this procedure are shown in figures 10 through 19, except where indicated.

With metal-seat constructions, lapping seating surfaces of the valve plug and seat ring (keys 5 and 4) can improve shutoff. (Deep nicks should be machined out rather than ground out.) Use a good quality lapping compound of a mixture of 280 to 600-grit. Apply the compound to the bottom of the valve plug.

Note

NotchFlo DST valves use spiral-wound gaskets. These gaskets provide their seal by being crushed and therefore should never be reused. This includes reusing a gasket after the lapping procedure has been performed.

An “old” gasket can be used to lap the seat, however the gasket must be replaced with a new gasket.

To preserve the effects of lapping, do not change either the position of the seat ring in the valve body cavity or the position of the cage on the seat ring after lapping the seating surfaces. When the parts are removed for cleaning and replacement of the “old” gaskets, return them to the original positions.

Use the following procedure to lap the seating surfaces.

1. Install the following parts according to the instructions presented in the trim replacement procedure: “old” seat ring gasket(s) (key 12), seat ring (key 4), cage (key 2), “old” bonnet gasket(key 11), and (if applicable) the “old” cage gaskets (key 65).
2. Proceed as appropriate:

For a NotchFlo DST balanced valve, install the valve plug and stem assembly (keys 5 and 6)--without seal ring (key 8)--into the cage.

For a NotchFlo DST unbalanced valve, install the valve plug and stem assembly (keys 5 and 6) into the cage.

3. Install the bonnet (key 18) over the valve stem, and secure the bonnet with four of the hex nuts (key 14).
4. Attach a handle, such as a piece of strap iron secured by stem locknuts, to the valve stem. Rotate the handle alternately in each direction to lap the seats.
5. After lapping, disassemble as necessary (you may mark the position of the seat ring and cage with a soft tip marker). Clean the seating surfaces, replace the gaskets, reassemble (taking care to return the seat ring and cage to their original positions), and test for shutoff. Repeat the lapping procedure if necessary.

Trim Replacement

⚠ WARNING

Observe the warning at the start of the Maintenance section.

After all trim maintenance has been completed, reassemble the valve body by following the numbered steps below. Be certain that all gasketed surfaces have been well cleaned. Key numbers referenced in this procedure are shown in figures 10 through 19, except where indicated.

CAUTION

Inspect the seat ring, cage, bonnet, and body gasket surfaces. These surfaces must be in good condition, with all foreign material removed. Small burrs less than approximately 0.076 mm (0.003 inches) in height (the thickness of a human hair) can be ignored. Scratches or burrs that run across the serrations are not permitted under any conditions, since they will prevent the gaskets from sealing properly.

1. Install the seat ring gasket (key 12) into the valve body. Install the seat ring (key 4).
2. For CL600, CL900, CL1500 4-Stage ≤ NPS 4, CL1500 6-Stage ≤ NPS 3 and CL2500 ≤ NPS 3 valves, install the second seat ring gasket (key 12) onto the seat ring.
For CL1500 4-Stage ≥ NPS 6, install the first cage gasket (key 65) onto the seat ring.
For CL1500 6-Stage ≥ NPS4 and CL2500 ≥ NPS 4 valves, install the gasket (key 68) onto the seat ring.
3. Install the cage.
4. For a NotchFlo DST balanced valve, install the anti-extrusion rings (key 63) onto the valve plug (key 5). Install the seal ring (key 8) onto the valve plug (key 5). Install the ring with the open side facing the valve plug stem end of the valve plug for flow-up applications (view A of figures 10 through 19). Slide the backup ring (key 9) onto the valve plug. Secure with the retaining ring (key 10).
5. Install the valve plug into the cage.
6. Install the bonnet gasket (key 11). For CL1500 4-Stage ≥ NPS 6, CL1500 6-Stage ≥ NPS4 and CL2500 ≥ NPS4 valves, install the second cage gasket (key 65) onto the cage.
7. Install the bonnet over the valve stem and onto the valve body.

Note

The prelubricated hex nuts (key 14) referred to in step 8 can be identified by a black film coating on the nut threads.

The proper bolting procedures in step 8 include—but are not limited to—ensuring that the bonnet stud threads are clean, and that the hex nuts are evenly tightened to the specified torque values.

Table 9. Actuator Groups by Type Number

Group 1 71 & 90 mm (2-13/16 and 3-9/16 Inch) Yoke Boss	Group 100 127 mm (5-Inch) Yoke Boss
585C 657 & 667 1008	585C 657
	Group 101 127 mm (5-Inch) Yoke Boss
	667

CAUTION

Failure to comply with good bonnet-to-body bolting practices and the torque values shown in tables 5, 6, and 7 may result in damage to the valve. Cheater bars or slug wrenches should not be used for this procedure.

Hot torquing is not recommended on CL900, CL1500, and CL2500 valves. When operating temperature has been reached, perform this torquing procedure once again on CL600 valves.

Note

Stud(s) and nut(s) should be installed such that the manufacturer's trademark and material grade marking is visible, allowing easy comparison to the materials selected and documented in the Emerson/Fisher serial card provided with this product.

⚠ WARNING

Personal injury or damage to equipment could occur if improper stud and nut materials or parts are used. Do not operate or assemble this product with stud(s) and nut(s) that are not approved by Emerson/Fisher engineering and/or listed on the serial card provided with this product. Use of unapproved materials and parts could lead to stresses exceeding the design or code limits intended for this particular service. Install studs with the material grade and manufacturer's identification mark visible. Contact your Emerson representative immediately if a discrepancy between actual parts and approved parts is suspected.

8. Lubricate the stud threads and the faces of the hex nuts (key 14) with anti-seize lubricant (not necessary if new factory prelubricated hex nuts are used). Install the hex nuts, but do not tighten them. Torque the nuts in a crisscross pattern to no more than 1/4 of the nominal torque value specified in table 5, 6, or 7. When all nuts are tightened to that torque value, increase the torque by 1/4 of the specified nominal torque and repeat the crisscross pattern. Repeat this procedure until all nuts are tightened to the specified nominal value. Apply the final torque value again and, if any nut still turns, tighten every nut again.
9. Install new packing and packing box parts per steps 15 and 16 of the Replacing Packing procedure. Be certain to observe the note given prior to step 15 of that procedure.
10. Mount the actuator by following the procedures in the actuator instruction manual. Check for packing leakage as the valve is being put into service. Retorque the packing flange nuts as required. See tables 3 and 4.

Parts Ordering

Each valve body-bonnet assembly is assigned a serial number which can be found on the valve. This same number also appears on the actuator nameplate when the valve is shipped from the factory as part of a control valve assembly. Refer to the serial number when contacting your [Emerson sales office](#) for technical assistance. When ordering replacement parts, reference the valve serial number to obtain the correct eleven-character part number for each part; the following Parts Kit and Parts List is for information only.

⚠ WARNING

Use only genuine Fisher replacement parts. Components that are not supplied by Emerson Automation Solutions should not, under any circumstances, be used in any Fisher valve, because they may void your warranty, might adversely affect the performance of the valve, and could cause personal injury and property damage.

Parts Kits

Standard Packing Repair Kits (Non Live-Loaded)

Stem Diameter, mm (Inches) Yoke Boss Diameter, mm (Inches)	12.7 (1/2) 71 (2-13/16)	19.1 (3/4) 90 (3-9/16)	25.4 (1) 127 (5)	31.8 (1-1/4) 127 (5, 5H)
PTFE (Contains keys 22, 24, 25, 26, 27)	RPACKX00022	RPACKX00032	RPACKX00342	RPACKX00352
Double PTFE (Contains keys 22, 24, 26, 27)	RPACKX00052	RPACKX00062	RPACKX00362	RPACKX00372
Single Graphite Ribbon/Filament (Contains keys 23 [ribbon ring], 23 [filament ring], 24, and 26)	RPACKX00112	RPACKX00122	---	---
Single Graphite Ribbon/Filament (Contains keys 23 [ribbon ring], 23 [filament ring], and 26)	---	---	RPACKX00532	RPACKX00542
Single Graphite Ribbon/Filament (Contains keys 23 [ribbon ring], 23 [filament ring])	RPACKX00142	RPACKX00152	---	---

ENVIRO-SEAL™ Packing Retrofit Kits

Retrofit kits include parts to convert valves with existing standard bonnets to the ENVIRO-SEAL packing box construction.

Refer to figure 7 for key numbers for PTFE packing, to figure 8 for key numbers for Graphite ULF packing, and to figure 9 for key numbers for duplex packing.

PTFE kits include keys 200, 201, 211, 212, 214, 215, 217, 218, tag, and cable tie. Graphite ULF kits include keys 200, 201, 207, 208, 209, 210, 211, 212, 214, 216, 217, tag, and cable tie. Duplex kits include keys 200, 201, 207, 209, 211, 212, 214, 215, 216, 217, tag, and cable tie.

Stems and packing box constructions that do not meet Fisher stem finish specifications, dimensional tolerances, and design specifications may adversely alter the performance of this packing kit.

For part numbers of individual components in the ENVIRO-SEAL packing kits, refer to instruction manual ENVIRO-SEAL Packing System for Sliding-Stem Valves, [D101642X012](#).

ENVIRO-SEAL Packing Retrofit Kits

PACKING MATERIAL	STEM DIAMETER AND YOKE BOSS DIAMETER, mm (INCH)			
	12.7 (1/2) 71 (2-13/16)	19.1 (3/4) 90 (3-9/16)	25.4 (1) 127 (5)	31.8 (1-1/4) 127 (5, 5H)
Double PTFE	RPACKXRT022	RPACKXRT032	RPACKXRT042	RPACKXRT052
Graphite ULF	RPACKXRT272	RPACKXRT282	RPACKXRT292	RPACKXRT302
Duplex	RPACKXRT222	RPACKXRT232	RPACKXRT242	RPACKXRT252

ENVIRO-SEAL Packing Repair Kits

Repair kits include parts to replace the “soft” packing materials in valves that already have ENVIRO-SEAL packing arrangements installed or in valves that have been upgraded with ENVIRO-SEAL retrofit kits.

Refer to figure 7 for key numbers for PTFE packing, to figure 8 for key numbers for Graphite ULF packing, and to figure 9 for key numbers for duplex packing.

PTFE repair kits include keys 214, 215, and 218. Graphite ULF repair kits include keys 207, 208, 209, 210, and 214. Duplex repair kits include keys 207, 209, 214, and 215.

Stems and packing box constructions that do not meet Fisher stem finish specifications, dimensional tolerances, and design specifications may adversely alter the performance of this packing kit.

For part numbers of individual components in the ENVIRO-SEAL packing kits, refer to instruction manual ENVIRO-SEAL Packing System for Sliding-Stem Valves, [D101642X012](#).

ENVIRO-SEAL Packing Repair Kits

Stem Diameter, mm (Inches) Yoke Boss Diameter, mm (Inches)	12.7 (1/2) 71 (2-13/16)	19.1 (3/4) 90 (3-9/16)	25.4 (1) 127 (5)	31.8 (1-1/4) 127 (5, 5H)
Double PTFE (Contains keys 214, 215, & 218)	RPACKX00202	RPACKX00212	RPACKX00222	RPACKX00232
Graphite ULF (Contains keys 207, 208, 209, 210, and 214)	RPACKX00602	RPACKX00612	RPACKX00622	RPACKX00632
Duplex (Contains keys 207, 209, 214, and 215)	RPACKX00302	RPACKX00312	RPACKX00322	RPACKX00332

Gasket Kits

Rating	Valve Size, NPS	Key Number	Part Number	Rating	Valve Size, NPS	Key Number	Part Number
CL300/CL600	1	Set	RGASKETXC72	CL1500 (6-stage)	1	Set	RGASKETXD42
		11	1R2859X0042			11	12B6757X012
		12	12B6758X012 (qty 2)			12	12B6758X012 (qty 2)
CL300/CL600	2	Set	RGASKETXC82	CL1500 (6-stage)	2	Set	RGASKETXD52
		11	1R3299X0042			11	12B6756X012
		12	1R309999442 (qty 2)			12	12B6755X012 (qty 2)
CL300/CL600	3	Set	RGASKETXC92	CL1500 (6-stage)	3	Set	RGASKETXE32
		11	1R3484X0042			11	GG03231X012
		12	1R384599442 (qty 2)			12	GG03232X012 (qty 2)
CL300/CL600	4	Set	RGASKETXD12	CL1500 (6-stage)	4	Set	RGASKETXE42
		11	1R3724X0042			11	GE26454X012
		12	1L8270X0012 (qty 2)			12	GE26456X012
CL300/CL600	6	Set	RGASKETXD22			65	10B5309X012 (qty 2)
		12	GG04987X012			68	18A8275X012
		65	GG01635X012 (qty 2)			Set	RGASKETXE52
CL300/CL600	8	Set	RGASKETXD32	CL1500 (6-stage)	6	11	GE26179X012
		11	1U5081X0052			12	GE26181X012
		12	1U508599442 (qty 2)			65	1P3680X0012 (qty 3)
		65	1U508599442			68	GG14893X012
		67	16A1942X012			Set	RGASKETXE12
CL900/CL1500	1	Set	RGASKETXD42	CL2500	1	11	12B9359X042
		11	12B6757X012			12	12B9360X052 (qty 2)
		12	12B6758X012 (qty 2)			Set	RGASKETXE22
CL900/CL1500	1-1/2	Set	RGASKETXD42	CL2500	2	11	12B4274X042
		11	12B6757X012			12	12B4275X042 (qty 2)
		12	12B6758X012 (qty 2)			Set	RGASKETXE32
CL900/CL1500	2	Set	RGASKETXD52	CL2500	3	11	GG03231X012
		11	12B6756X012			12	GG03232X012 (qty 2)
		12	12B6755X012 (qty 2)			Set	RGASKETXE42
CL900/CL1500	3	Set	RGASKETXD62	CL2500	4	11	GE26454X012
		11	12B6027X012			12	GE26456X012
		12	12B6030X012 (qty 2)			65	10B5309X012 (qty 2)
CL900/CL1500	4	Set	RGASKETXD72			68	18A8275X012
		11	12B9350X012			Set	RGASKETXE52
		12	12B9351X012 (qty 2)			11	GE26179X012
CL900/CL1500	6	Set	RGASKETXD82	CL2500	6	12	GE26181X012
		11	GE26041X012			65	1P3680X0012 (qty 3)
		12	GE26043X012			68	GG14893X012
		65	GE26042X012 (qty 2)				
CL900/CL1500	8	Set	RGASKETXD92				
		11	GE25826X012				
		12	GE25828X012				
		65	GE25827X012 (qty 3)				

Figure 7. Typical ENVIRO-SEAL Packing System with PTFE Packing

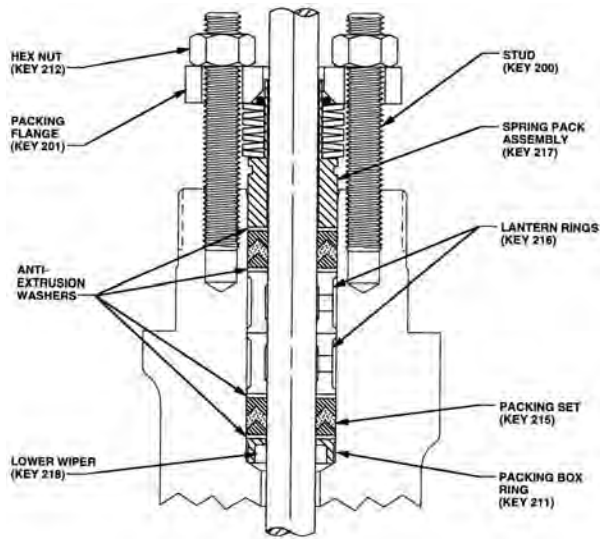

A6297-1

Figure 9. Typical ENVIRO-SEAL Packing System with Duplex Packing

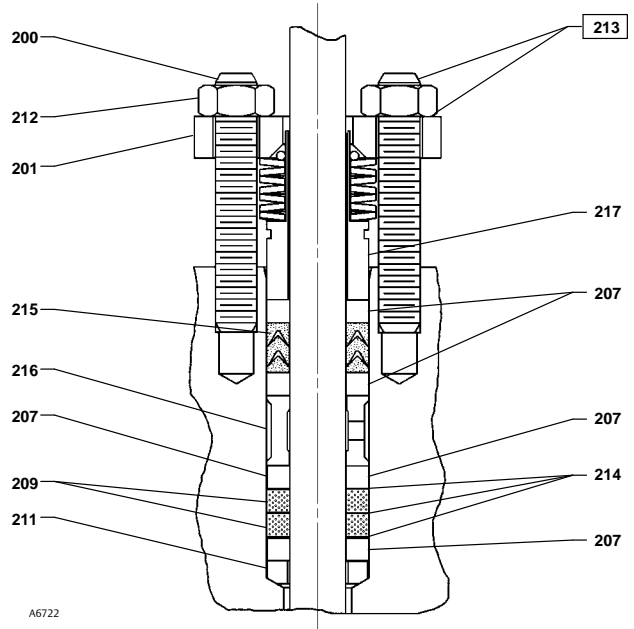

A6722

Figure 8. Typical ENVIRO-SEAL Packing System with Graphite ULF Packing

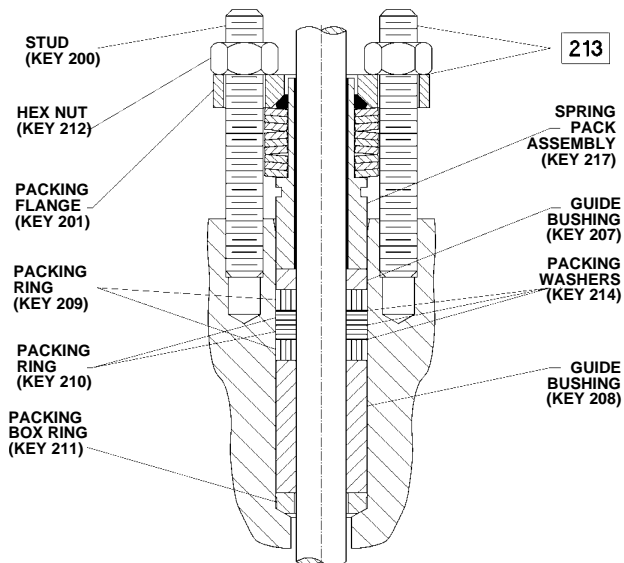

3984612/A

Parts List

Numerous available combinations of valve parts make selection of some parts difficult; when ordering valve parts for which a part number is not listed, provide the valve serial number with the order, permitting proper selection of replacement parts to be made at the factory.

Note

For part numbers not shown, contact your [Emerson sales office](#).

Key	Description	Key	Description
1	Valve Body If you need a valve body as a replacement part, order by valve size, serial number, and desired material.	16	Nameplate (not shown)
2*	Cage	17	Wire (not shown)
4*	Seat Ring	18	Bonnet---
5*	Valve Plug or Plug/Stem Assembly		If you need a bonnet as a replacement part, order by valve size and stem diameter, serial number, and desired material.
6*	Valve Stem	19	Packing Flange
7*	Pin	20	Stud Bolt
8*	Seal Ring	21	Hex Nut
9*	Back Up Ring	22*	Packing Set
10*	Retaining Ring	23*	Packing Ring
11*	Bonnet Gasket	24	Spring or Lantern Ring
12*	Seat Ring Gasket	25	Washer, Special
13	Stud, Cont Thd	26*	Packing Box Ring
14	Hex Nut	27*	Upper Wiper
15	Anti-Seize Lubricant	28	Follower
		29	Stud Bolt
		30	Hex Nut
		32	Yoke Locknut
		38	Drive Screw
		41	Flow Arrow
		63*	Anti-Extrusion Ring
		65*	Cage Gasket
		66*	Carbon Steel Washer
		68	Gasket

Figure 10. Fisher NotchFlo DST CL600 Balanced Globe Valve Assembly (NPS 1 through 8)

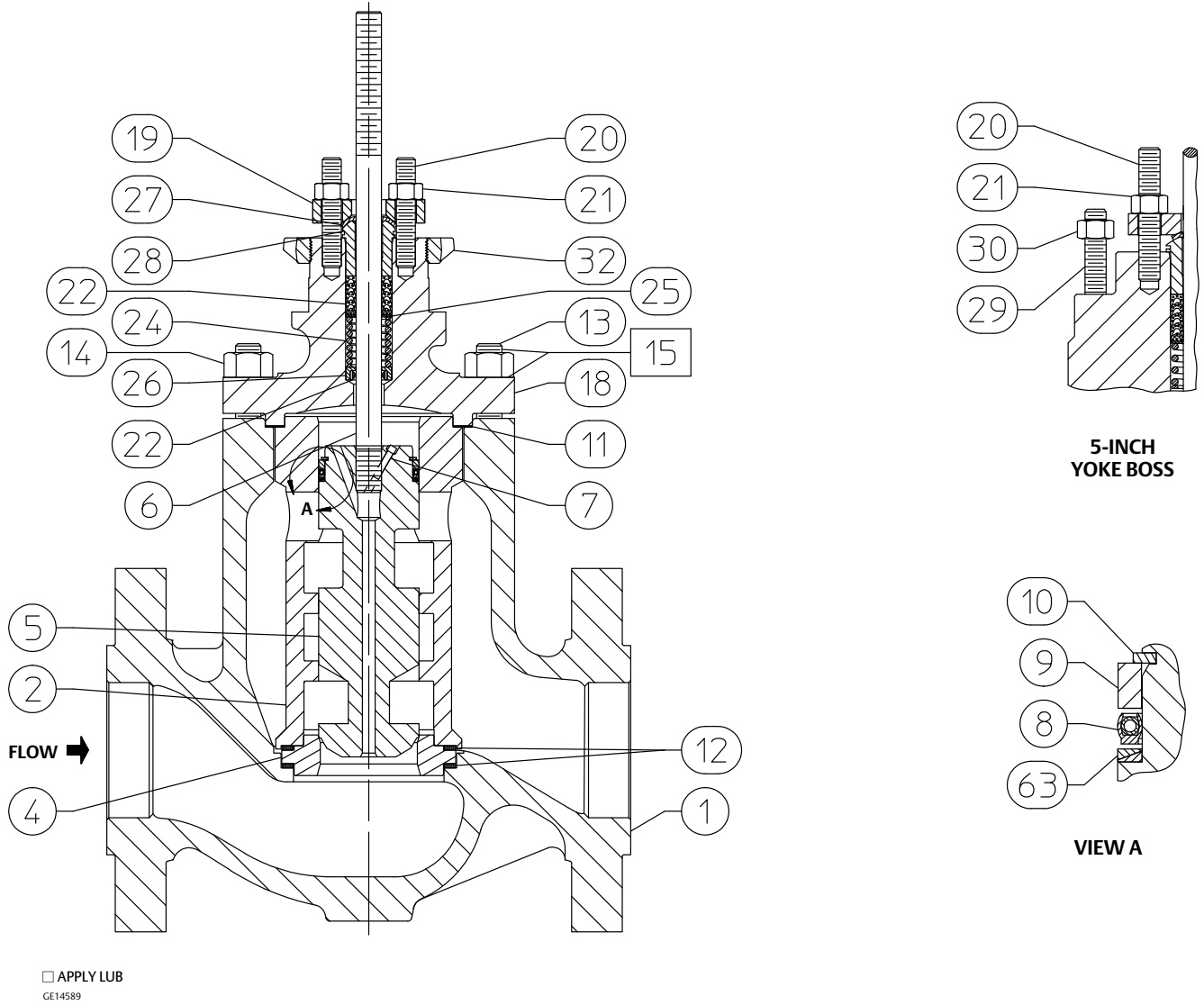
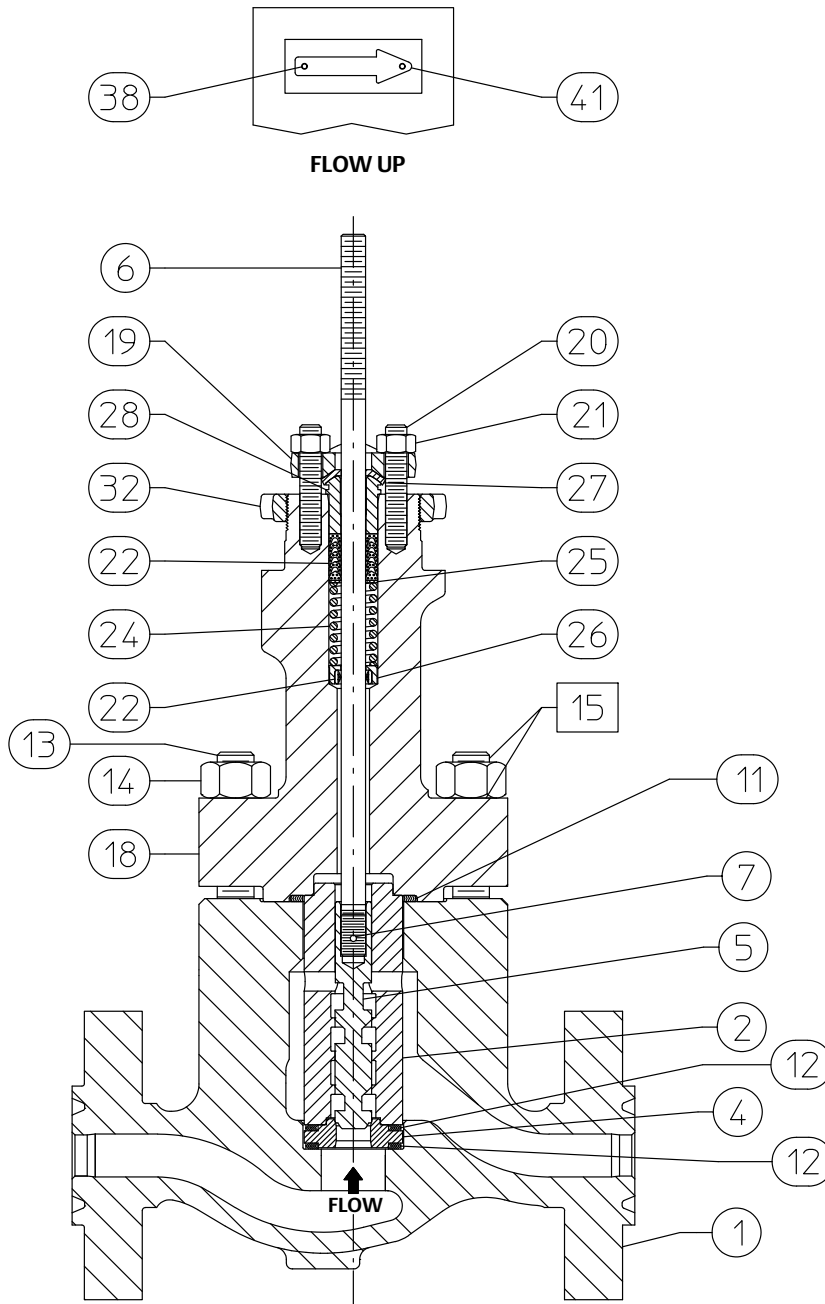

Figure 11. Fisher NotchFlo DST CL900 and 1500 Unbalanced Globe Valve Assembly (NPS 1 to 1-1/2)



□ APPLY LUB
GG11704-A

Figure 12. Fisher NotchFlo DST CL900 and 1500 Balanced Globe Valve Assembly (NPS 2 through 4)

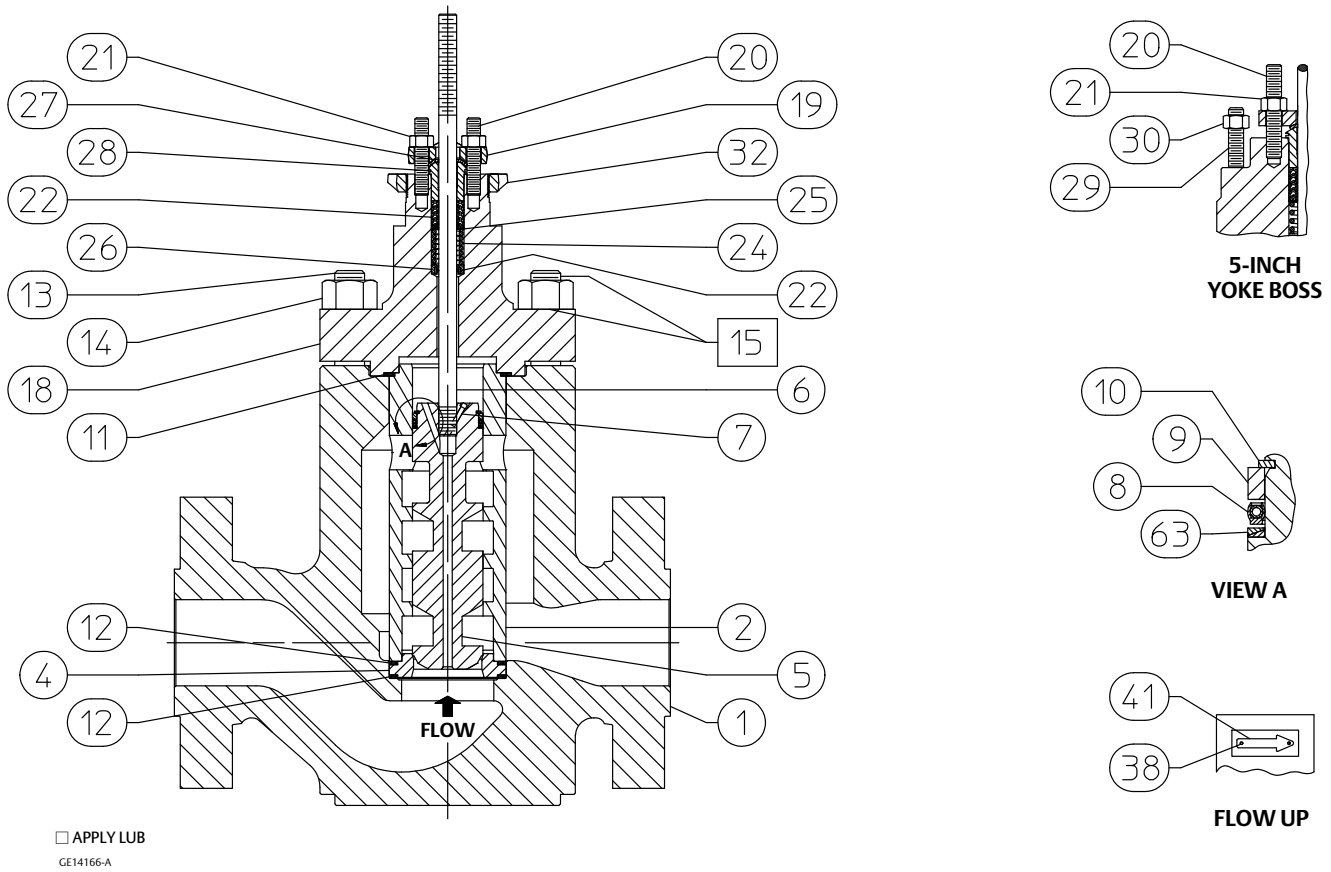

Figure 13. Fisher NotchFlo DST CL900 and 1500 Unbalanced Angle Valve Assembly (NPS 1 to 1-1/2)

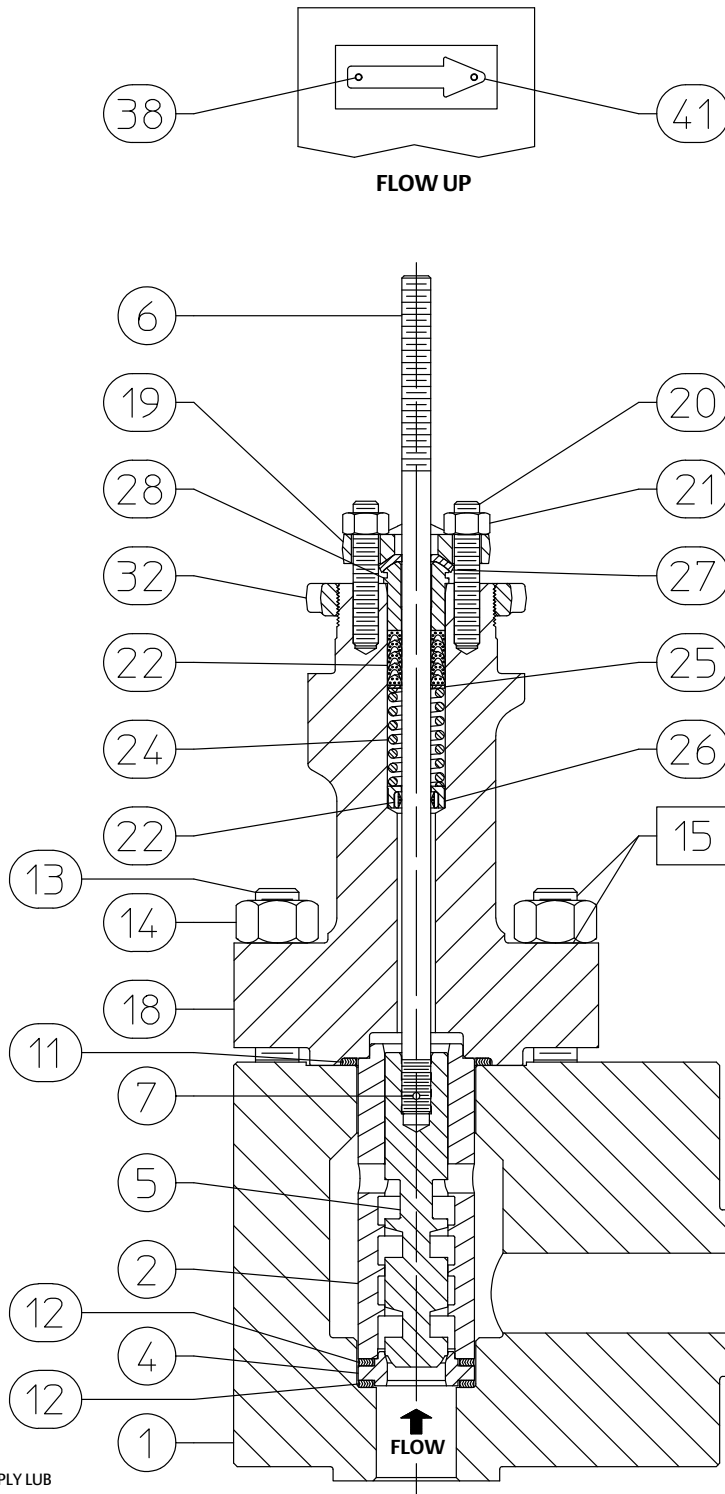

Figure 14. Fisher NotchFlo DST CL900 and 1500 Balanced Angle Valve Assembly (NPS 2 through 4) and CL600 Balanced Angle Valve Assembly (NPS 1 through 8)

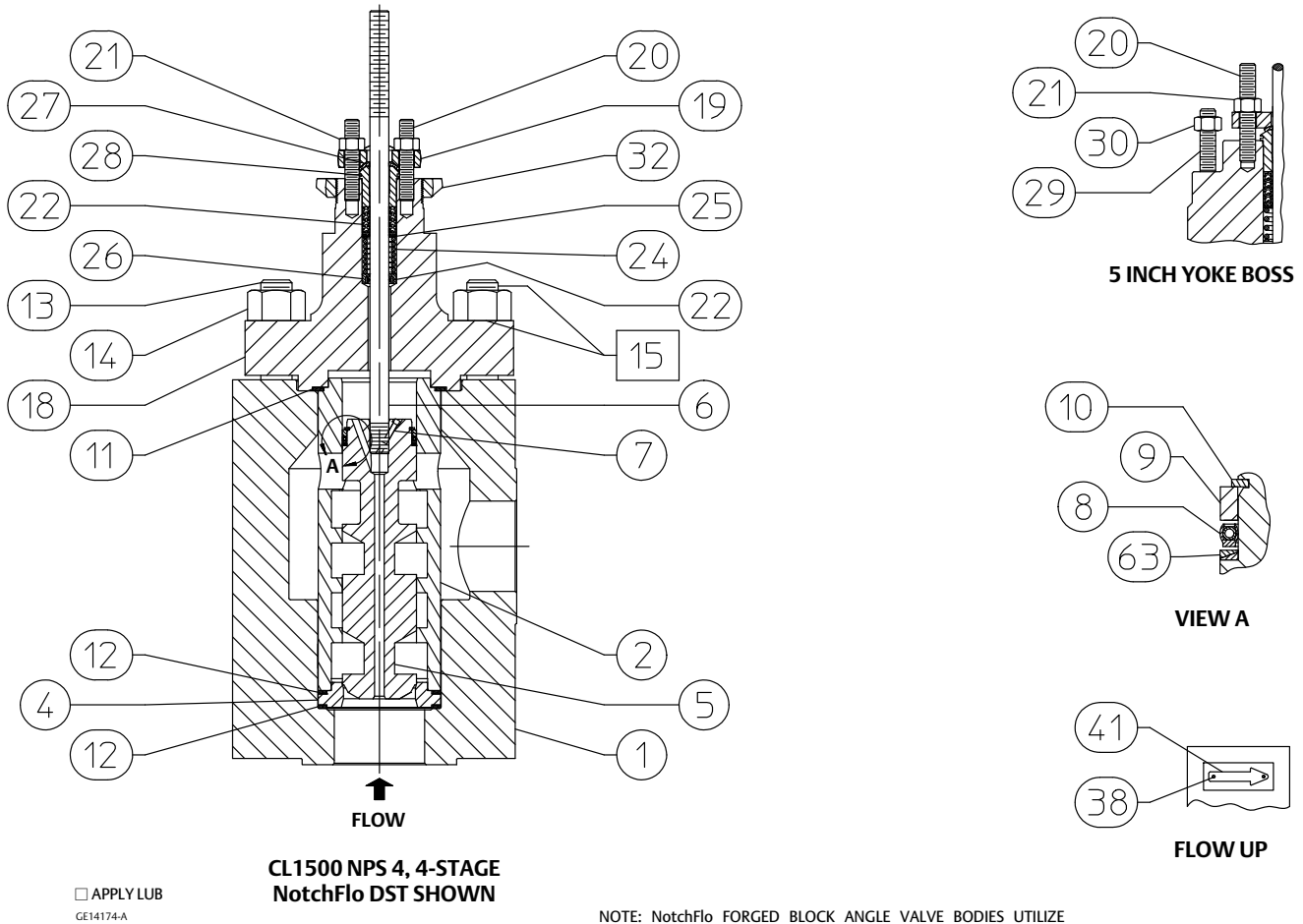

Table 10. Block Forged Valve Body Line Bolting

Valve Size, NPS	Rating	Bolt Information	Depth of Thread	Quantity (Inclusive of Inlet and Outlet Flange)
1	CL300/600	5/8-11 UNC-2B	0.94	8
2		5/8-11 UNC-2B	0.94	16
3		3/4-10 UNC-2B	1.13	16
4	CL600	7/8-9 UNC-2B	1.32	16
	CL300	3/4-10 UNC-2B	1.13	16
6	CL600	1-8 UN-2B	1.5	24
	CL300	3/4-10 UNC-2B	1.23	24
8	CL600	1 1/8-8 UN-2B	1.69	24
	CL300	7/8-9 UNC-2B	1.31	24
1	CL900/1500	7/8-9 UNC-2B	1.31	8
1-1/2		1-8 UNC-2B	1.5	8
2		7/8-9 UNC-2B	1.31	16
3	CL900	7/8-9 UNC-2B	1.31	16
	CL1500	1 1/8-8 UN-2B	1.69	16
4	CL900	1 1/8-8 UN-2B	1.41	2
		1 1/8-8 UN-2B	1.69	14
	CL1500	1 1/4-8 UN-2B	1.45	4
		1 1/4-8 UN-2B	1.50	4
6	CL1500	1 1/4-8 UN-2B	1.88	8
		1 3/8-8 UN-2B	1.72	6
8	CL1500	1 3/8-8 UN-2B	2.06	18
		1 5/8-8 UN-2B	1.8	2
1	CL2500	1 5/8-8 UN-2B	2.44	22
2		7/8-9 UNC-2B	1.31	8
3	CL2500	1-8 UNC-2B	1.5	16
4	CL2500	1 1/4-8 UN-2B	1.87	16
		1 1/2-8 UN-2B	1.65	2
		1 1/2-8 UN-2B	2.25	6
6	CL2500	1 1/2-8 UN-2B	2.13	8
		2-8 UN-2B	2.5	2
		2-8 UN-2B	3	6
		2-8 UN-2B	2.65	8

Figure 15. Fisher NotchFlo DST CL1500 Cast Angle Valve Assembly (NPS 1 through 8)

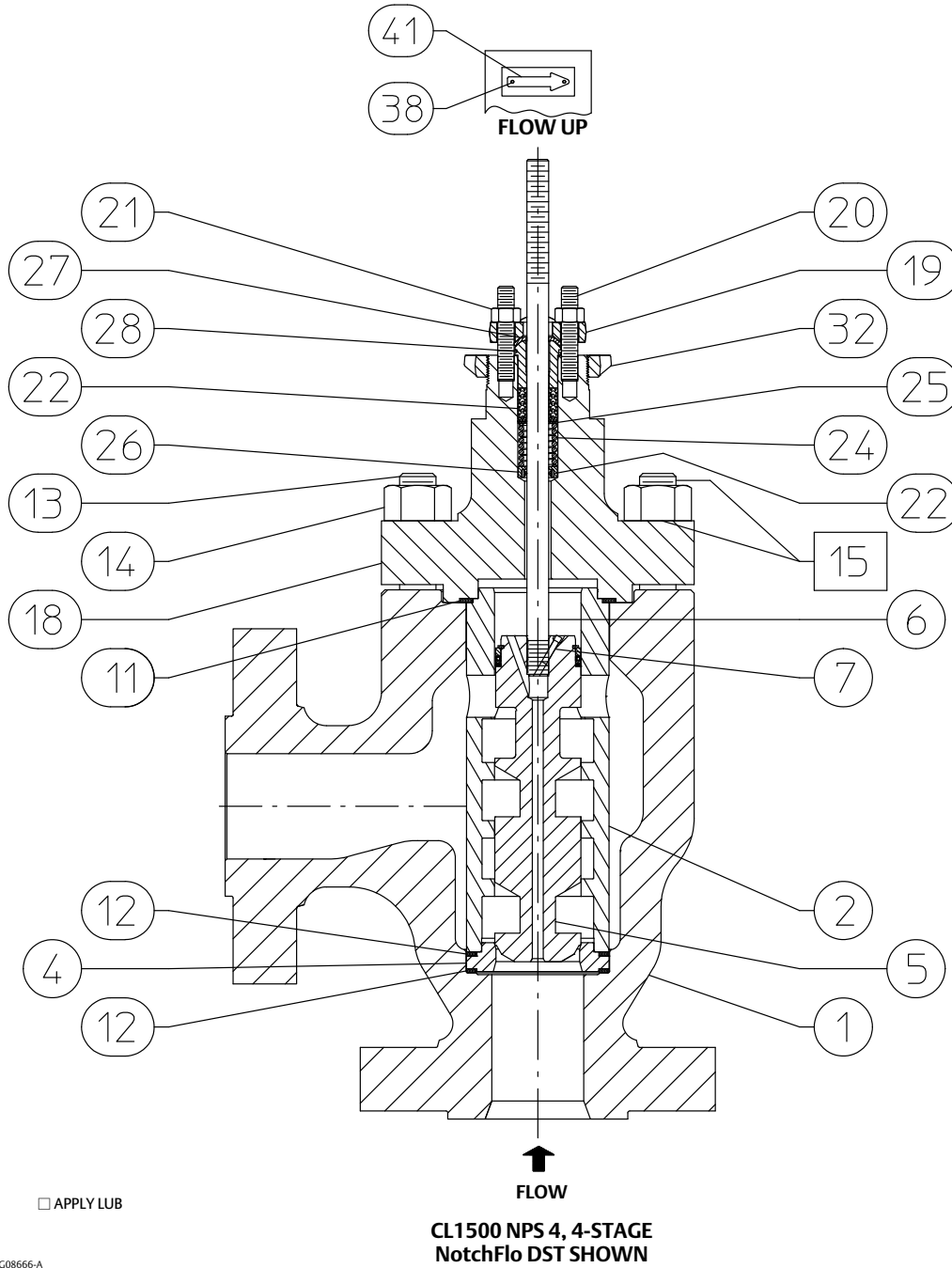

Figure 16. Fisher NotchFlo DST CL1500 ≥ NPS 6 Balanced Angle Valve Assembly

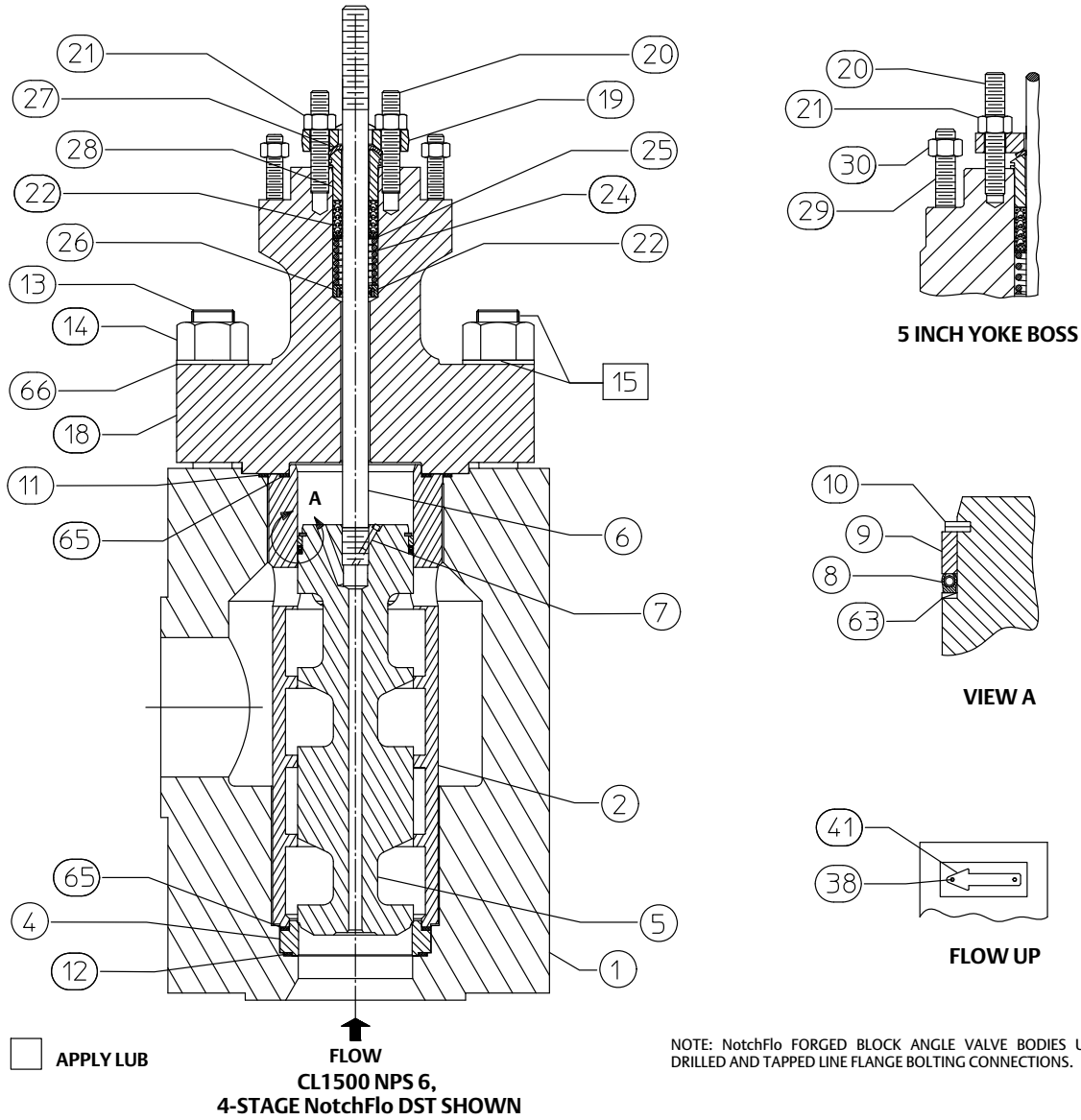

Figure 17. Fisher NotchFlo DST CL2500 6-Stage Unbalanced Angle Valve Assembly (NPS 1)

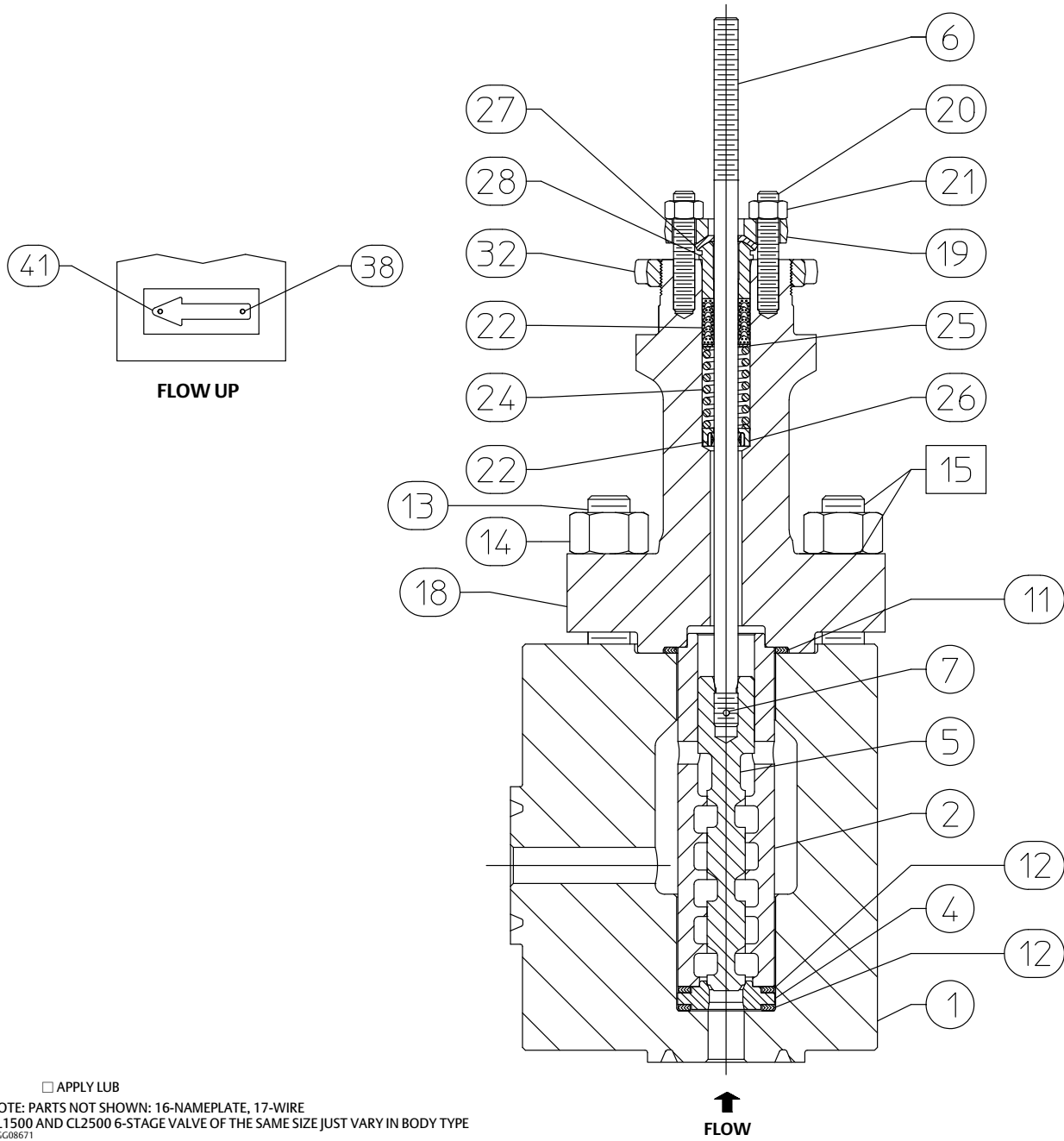
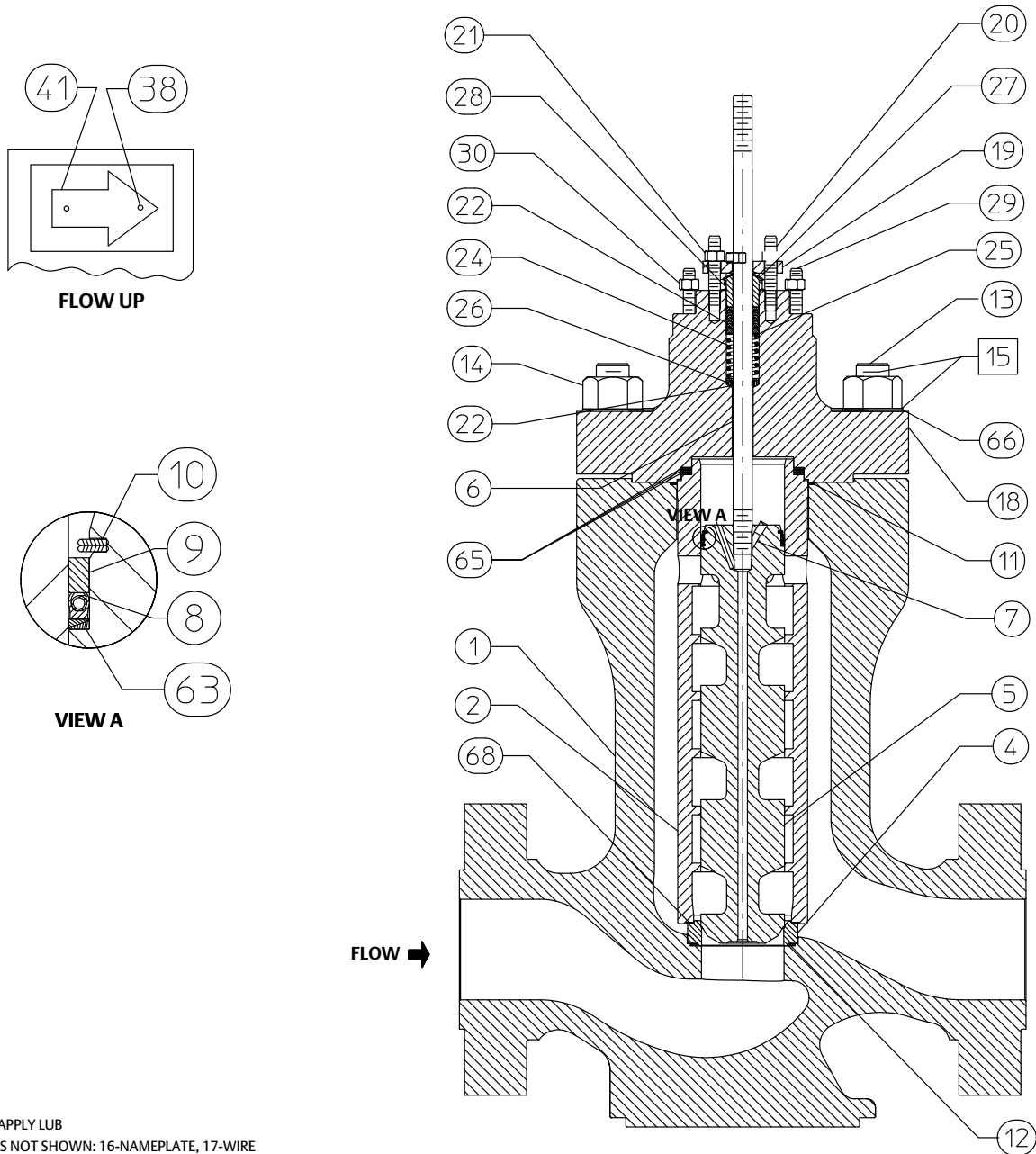

Figure 18. Fisher NotchFlo DST CL1500 and CL2500 6-Stage Globe Valve Assembly (NPS 4 and 6)



□ APPLY LUB

NOTE: PARTS NOT SHOWN: 16-NAMEPLATE, 17-WIRE
CL1500 AND CL2500 6-STAGE VALVE OF THE SAME SIZE JUST VARY IN BODY TYPE

GC56616

Figure 19. Fisher NotchFlo DST CL2500 6-Stage Cast Angle Valve Assembly (NPS 2 and 3)

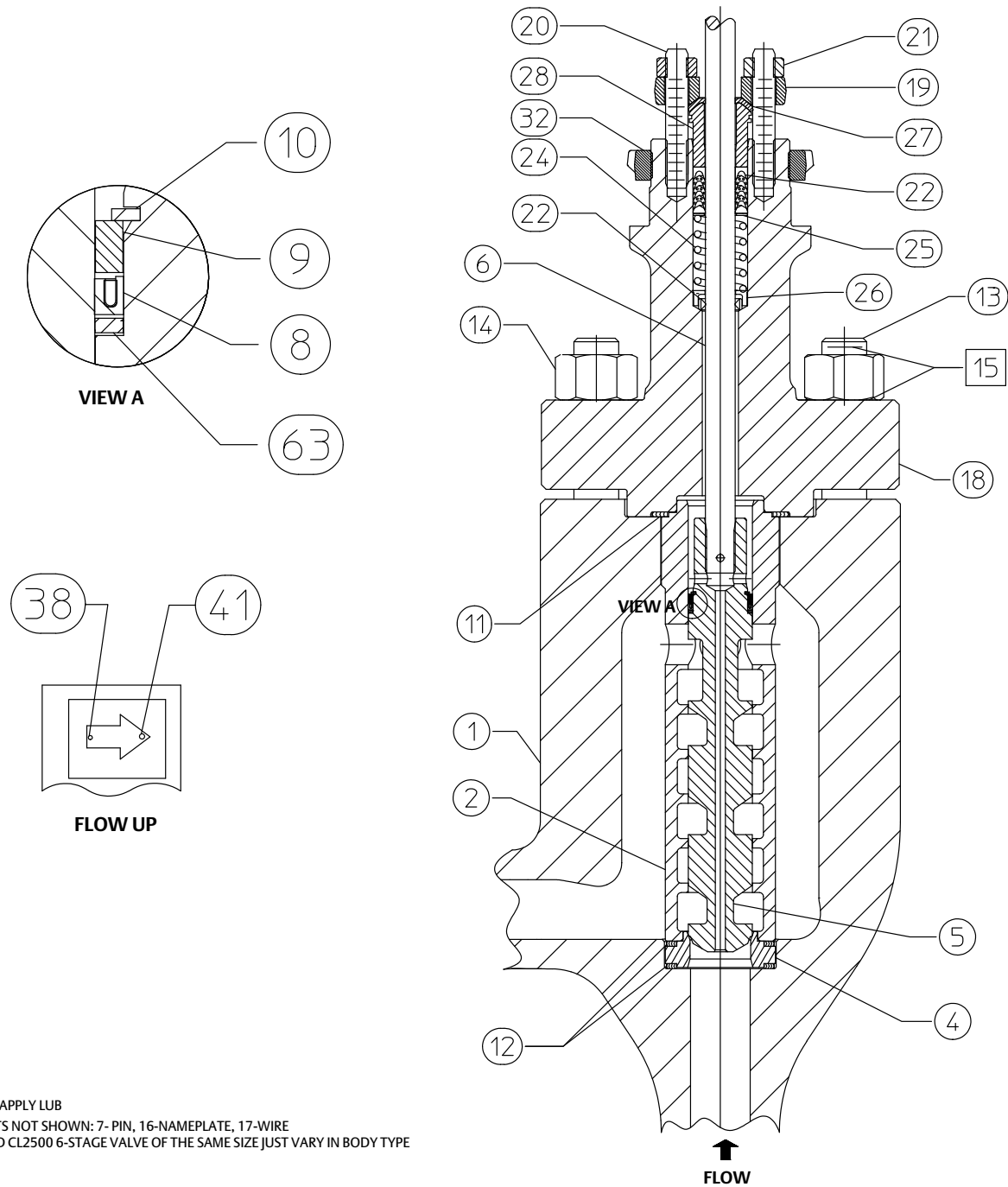

Neither Emerson, Emerson Automation Solutions, nor any of their affiliated entities assumes responsibility for the selection, use or maintenance of any product. Responsibility for proper selection, use, and maintenance of any product remains solely with the purchaser and end user.

Fisher, NotchFlo, and ENVIRO-SEAL are marks owned by one of the companies in the Emerson Automation Solutions business unit of Emerson Electric Co. Emerson Automation Solutions, Emerson, and the Emerson logo are trademarks and service marks of Emerson Electric Co. All other marks are the property of their respective owners.

The contents of this publication are presented for informational purposes only, and while every effort has been made to ensure their accuracy, they are not to be construed as warranties or guarantees, express or implied, regarding the products or services described herein or their use or applicability. All sales are governed by our terms and conditions, which are available upon request. We reserve the right to modify or improve the designs or specifications of such products at any time without notice.

Emerson Automation Solutions
Marshalltown, Iowa 50158 USA
Sorocaba, 18087 Brazil
Cernay 68700 France
Dubai, United Arab Emirates
Singapore 128461 Singapore

www.Fisher.com

