

# Maintenance Packing System for Fisher™ Sliding-Stem Valves in Power Plant Applications

## Contents

Introduction .....	1
Scope of Manual .....	1
Description .....	2
Installation .....	3
Tightening Procedures .....	4
Other Considerations .....	5
Parts Ordering .....	5

Figure 1. Fisher easy-e Valve Bonnet with Maintenance Packing System

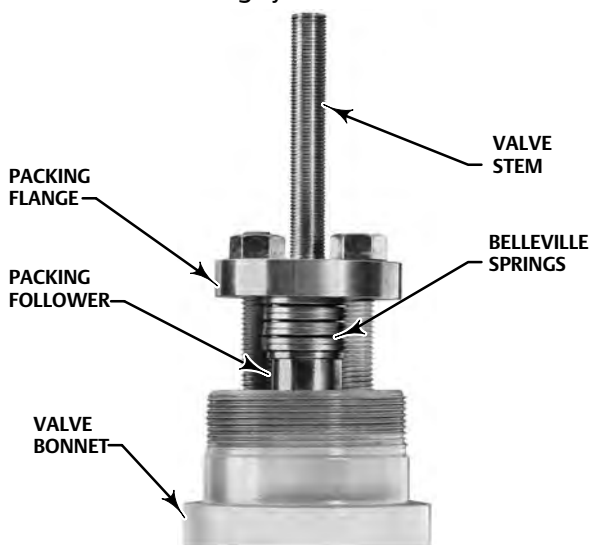

W5814-1\*

## Introduction

### Scope of Manual

This instruction manual includes installation and parts information for a Maintenance Packing System that uses ENVIRO-SEAL™ live-loaded components (see figure 1). This system can be installed in Fisher Sliding-Stem valves with 12.7, 19.1, 25.4, 31.8 mm, and 50.8 mm (1/2, 3/4, 1, 1-1/4, and 2-inch) diameter stems as shown in table 2. Refer to appropriate valve and actuator instruction manuals for necessary information relating to the disassembly and assembly of the valve and actuator.



Do not install, operate, or maintain Maintenance Packing Systems without being fully trained and qualified in valve, actuator, and accessory installation, operation, and maintenance. To avoid personal injury or property damage, it is important to carefully read, understand, and follow all the contents of this manual, including all safety cautions and warnings. If you have any questions about these instructions, contact your [Emerson sales office](#) before proceeding.

Table 1. Specifications

<p><b>Applicable Product Types and Stem Diameters</b> See table 2</p> <p><b>Pressure Limit (1)</b> Maximum Pressure: 310 bar (4500 psi)</p>	<p><b>Temperature Limits(2)</b> Minimum: -40°C (-40°F) Maximum: 524°C (975°F)</p>
---	---

1. The pressure/temperature limits in this manual, in the valve literature, and any applicable code or standard limitation, should not be exceeded.  
2. The valves shown are only guidelines. These guidelines can be exceeded, but shortened packing life or increased leakage might result. The temperature ratings apply to the actual packing temperature, not to the process temperature.

## Description

This Maintenance Packing System is available only for field Installation in Fisher valves. It is intended for use in Steam Service in conventional (non-nuclear) power plants that exceed the pressure and temperature limits of ENVIRO-SEAL packing offerings.

This system is intended for use only in non-environmental applications and has not been tested for fugitive emission service. The external live-loading provides elevated packing stress and compensates for packing wear and consolidation. Periodic adjustment of the packing nuts may be required until the packing nut torque stabilizes.

Maintenance Packing System systems utilize Belleville (coned-disk) springs located on a PTFE lined follower. If the piping and valve are insulated, do not allow insulation to extend above the yoke boss surface. Insure the packing follower is exposed to ambient air conditions to provide adequate cooling. For applications that exceed the temperature capability of the standard PTFE lined follower, a PEEK lined follower is available. Contact your [Emerson sales office](#) for details.

Table 2. Fisher Sliding-Stem Product Availability for Maintenance Packing System

VALVE TYPE(1)	STEM DIAMETER, mm (INCHES)				
	12.7 (1/2)	19.1 (3/4)	25.4 (1)	31.8 (1-1/4)	50.8 (2)
A	X	X	X	X	---
CAV4	---	X	X	X	X
DBQ	X	X	X	X	---
easy-e (ED, ES, ET, EW, EZ)	X	X	X	X	---
EH	X	X	X	X	X
ENA	---	---	---	X	X
FB	---	---	X	X	X
HP	X	X	X	X	---
YD	X	X	X	X	---
YS	X	X	X	X	---

1. Contact your [Emerson sales office](#) for valves not listed.

# Installation

If you are changing the packing system, it is good practice to review actuator sizing, as packing friction will change. See tables 3 and 4 for information on packing friction.

## ⚠ WARNING

**Avoid personal injury from sudden release of process pressure or uncontrolled movement of parts. Before performing any maintenance operations:**

- Do not remove the actuator from the valve while the valve is still pressurized.
- Always wear protective gloves, clothing, and eyewear when performing any maintenance operations to avoid personal injury.
- Disconnect any operating lines providing air pressure, electric power, or a control signal to the actuator. Be sure the actuator cannot suddenly open or close the valve.
- Use bypass valves or completely shut off the process to isolate the valve from process pressure. Relieve process pressure from both sides of the valve. Drain the process media from both sides of the valve.
- Vent the power actuator loading pressure and relieve any actuator spring precompression.
- Use lock-out procedures to be sure that the above measures stay in effect while you work on the equipment.
- The valve packing box may contain process fluids that are pressurized, *even when the valve has been removed from the pipeline*. Process fluids may spray out under pressure when removing the packing hardware or packing rings, or when loosening the packing box pipe plug.
- Check with your process or safety engineer for any other hazards that may be present from exposure to process media.

If you are installing the system in a valve that is still connected to an actuator, remove the actuator from the valve to provide sufficient space to install the packing assembly. If a spring-return actuator is used, it is possible that disconnecting the stem connector will allow the spring to force the actuator to the end of its travel. Be sure the actuator spring is resting on its travel stop. Refer to the appropriate valve and actuator instruction manuals to remove the actuator.

Remove old packing parts from the packing box by using the valve instruction manual procedures. Both the valve stem surface condition and the packing bore are critical in obtaining a good seal. If the valve stem surface is scratched, nicked, or worn, replace the valve stem before installing the Maintenance Packing System. Check the condition of the packing bore and clean or hone it out, as necessary. Refer to the appropriate valve instruction manual to replace the valve stem.

Then proceed as follows:

1. The original packing flange studs used for standard packing arrangements should be long enough to accommodate the retrofit kit parts. If you determine that the existing studs and nuts should be replaced however, due to their condition, replace them with the studs and nuts (keys 200 and 212) specified in the parts section of this manual.
2. Carefully remove the old packing parts from the packing box. If the valve stem or packing box wall is scratched or damaged, it can cause excessive leakage. If the valve stem needs to be replaced, or any other valve part, refer to the appropriate valve instruction manual for replacement procedures. Complete all valve maintenance before installing the Maintenance Packing System into the bonnet.

Table 3. Packing Friction at Ambient Temperature

VALVE STEM DIAMETER		MAINTENANCE PACKING	
mm	Inches	Newtons	Pounds (Force)
12.7	1/2	1980	445
19.1	3/4	4580	1030
25.4	1	7250	1630
31.8	1-1/4	9470	2130

Table 4. Packing Friction at Elevated Temperature 315°C (600°F)

VALVE STEM DIAMETER		MAINTENANCE PACKING	
mm	Inches	Newtons	Pounds (Force)
12.7	1/2	760	170
19.1	3/4	1730	390
25.4	1	2740	615
31.8	1-1/4	3560	800

**Note**

Ensure the Belleville springs are stacked properly and packing box parts are assembled in the correct order (see figure 2). Packing parts cannot function properly if the Belleville springs or other packing parts are not stacked correctly.

- Use figure 2 to ensure that the packing parts and spring pack are assembled in the correct order. Install the packing parts into the packing box.
- Install the spring pack assembly (key 217), with the attached springs, onto the stem. Remove the O-Ring and discard it.
- Install the packing flange (key 201) with the chamfer away from the springs as shown in figure 2. Install the packing box nuts (key 212). Hand tighten them.

**Note**

Lubrication (key 213) is required for the packing studs and nuts.

Although it is important to properly lubricate the stud threads and internal nut threads, it is also important to properly lubricate the contacting face of the nut. See figure 2 for lubrication locations.

## Tightening Procedures

- The intended packing stress for this system is approximately 6000 psi which requires the Belleville springs to be compressed 85% of their maximum deflection. The torque values in table 5 can be used as a guideline for 85% spring compression. These values are based on generous lubrication of the packing studs and nuts with a nickel anti-seize lubricant.
- Refer to the appropriate valve and actuator instruction manuals when connecting the valve to the actuator. The braided components in this packing system require significant consolidation before the nut torque will stabilize. Stroke the valve and retorque until the consolidation process is complete and the specified packing nut torque is maintained.

Table 5. Packing Nut Torque for 414 bar (6000 psi) Packing Stress<sup>(1)</sup>

STEM SIZE		TORQUE		
mm	Inch	N•m	lbf•in	lbf•ft
12.7	1/2	11.4	100	8.4
19.1	3/4	28.5	250	21
25.4	1	64	560	47
31.8	1-1/4	75	660	55

1. For A, DBQ, easy-e, EH, FB, HP, YD, and YS valves.

## Other Considerations

Check the condition of the packing bore after you have removed the packing. An easy method for cleaning debris and minor imperfections from the bore is to use a brake cylinder hone attached to an electric drill. This method often does a good job of cleaning the packing bore without changing the dimension of the bore. Inspect the packing bore for damage. Damaged packing bores must be repaired or replaced.

## Parts Ordering

Each valve assembly is assigned a serial number that can be found on the valve body. Refer to this serial number when contacting your [Emerson sales office](#) for technical assistance. When ordering replacement parts, refer to this serial number and to the part description and part number from the following parts list. When ordering replacement parts, refer to the serial number and the 11-character part number for each part required from the following parts list.

### **⚠ WARNING**

**Use only genuine Fisher replacement parts. Components that are not supplied by Emerson Automation Solutions should not, under any circumstances, be used in any Fisher valve, because they may void your warranty, might adversely affect the performance of the valve, and could cause personal injury and property damage.**

---

## Parts List

Key	Description	Key	Description
200	Stud	212	Packing Nut
201	Packing Flange	213*	Anti-Seize Lubricant
207*	Guide Bushing	214*	Packing Washer
209*	Packing Ring	217	Spring Pack Assembly
210*	Packing Ring	220*	Packing Ring
211	Packing Box Ring	221*	Packing Washer

See following table  
See following table  
See following table  
See following table  
See following table  
See following table

Table 6. Maintenance Packing Components for Fisher easy-e Valves (see figure 2)

KEY NUMBER	PACKING COMPONENT	VALVE STEM SIZE, mm (INCHES)									
		12.7 (1/2)	QTY	19.1 (3/4)	QTY	25.4 (1)	QTY	31.8 (1-1/4)	QTY	50.8 (2)	QTY
200	Stud	1E944435222	2	1E944935222	2	0V002535222	2	1N356535222	2	1C7725X0032	3
201	Packing Flange	12B6924X012	1	12B6925X012	1	12B6654X012	1	12B6680X012	1	GE26167X012	1
207*	Guide Bushing	12B5782X012	6	12B5784X012	5	12B5786X012	5	12B5788X012	5	12B5790X012	5
209*	Packing Ring	12B5799X012	2	12B5800X012	2	12B5801X012	2	12B5802X012	2	12B5803X012	2
210*	Packing Ring	14B7498X012	2	14B7520X012	2	14B7521X012	2	14B7522X012	2	17B3077X012	2
211	Packing Box Ring	12B5775X012	1	12B5776X012	1	12B5777X012	1	12B5778X012	1	12B5779X012	1
212	Packing Nut	1E944535252	2	1E944635252	2	1A343335252	2	1A368135252	2	1A440935252	3
213*	Anti-Seize Lubricant	Not provided with packing									
214*	Packing Washer	12B6937X012	3	12B6938X012	3	12B6939X012	3	12B6940X012	3	19B4144X012	3
217	Spring Pack Assembly	GH08641X012	1	GH08641X022	1	GH08641X032	1	GH08641X042	1	GH08641X052	1
220*	Packing Ring	1E3190X0652	3	1E3191X0542	3	1D7518X0292	3	1D7520X0282	3	1N2600X0072	3
221*	Packing Washer	GH08637X012	4	GE63540X022	4	GH08638X012	4	GH08639X012	4	GH08640X012	4

Figure 2. Maintenance Packing for Fisher easy-e Valves

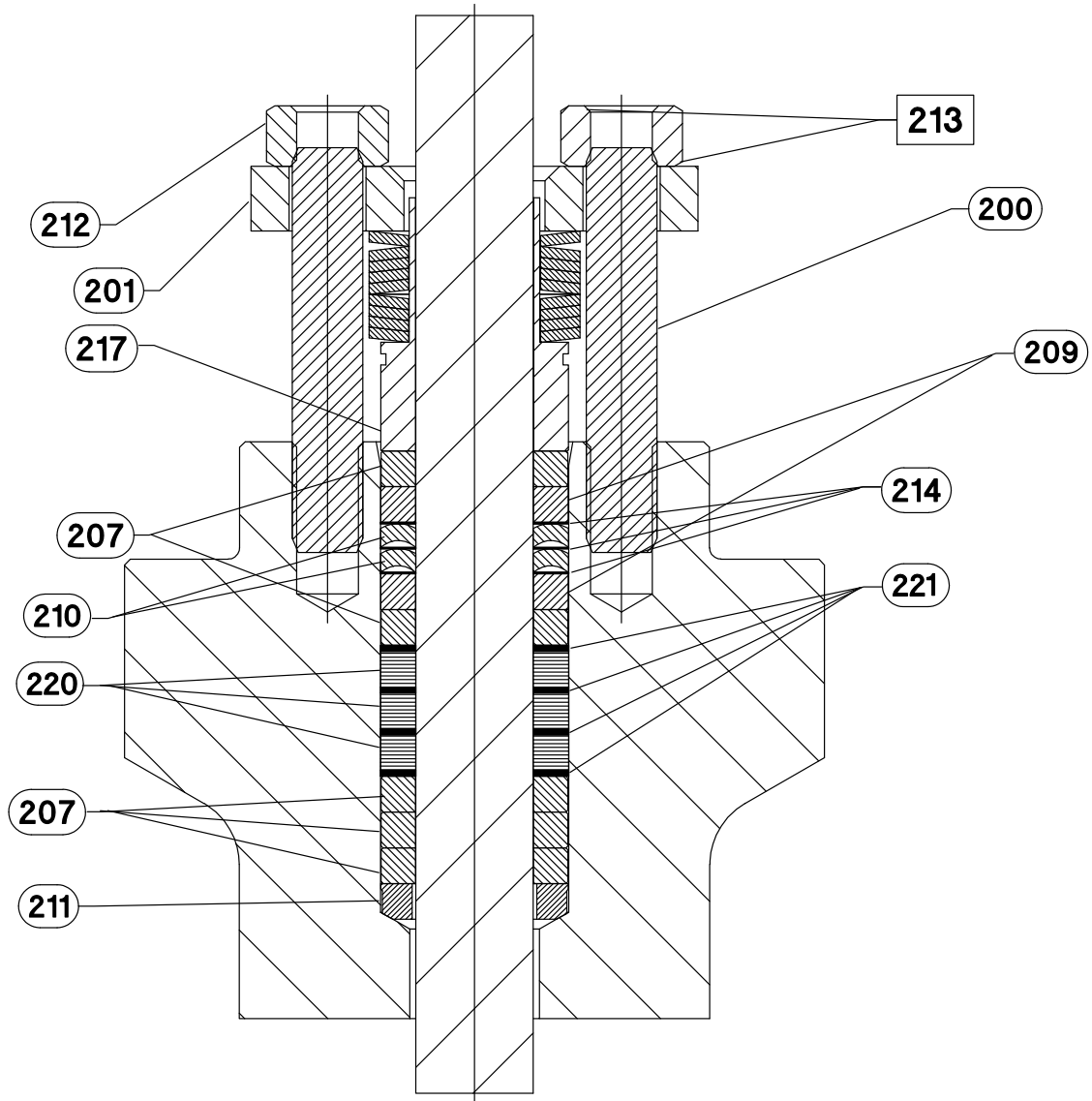

**Neither Emerson, Emerson Automation Solutions, nor any of their affiliated entities assumes responsibility for the selection, use or maintenance of any product. Responsibility for proper selection, use, and maintenance of any product remains solely with the purchaser and end user.**

Fisher, ENVIRO-SEAL, and easy-e are marks owned by one of the companies in the Emerson Automation Solutions business unit of Emerson Electric Co. Emerson Automation Solutions, Emerson, and the Emerson logo are trademarks and service marks of Emerson Electric Co. All other marks are the property of their respective owners.

The contents of this publication are presented for informational purposes only, and while every effort has been made to ensure their accuracy, they are not to be construed as warranties or guarantees, express or implied, regarding the products or services described herein or their use or applicability. All sales are governed by our terms and conditions, which are available upon request. We reserve the right to modify or improve the designs or specifications of such products at any time without notice.

**Emerson Automation Solutions**  
Marshalltown, Iowa 50158 USA  
Sorocaba, 18087 Brazil  
Cernay 68700 France  
Dubai, United Arab Emirates  
Singapore 128461 Singapore

[www.Fisher.com](http://www.Fisher.com)

