

ASCO Redundant Control System

2003B Enclosure without Diagnostics

2003BP Panel Mount without Diagnostics

Operation & Maintenance Guide



Operation & Maintenance Guide

Redundant Control System

Table of Contents

PRODUCT DESCRIPTION	3
GENERAL SPECIFICATIONS	4
INSTALLATION	4
Section 1. - Normally Closed.	6
1. General Operation and Testing.....	6
2. Maintenance: Valve Replacement.....	6
Section 2.	7
1. Functional Test Certification.....	7
2. Spare Parts.....	7
3. Packaging.....	7
4. Disclaimer.....	7

Documentation Conventions

This guide uses the following typographic conventions:

EXAMPLE

NOTE



Description
Notes containing supplementary information.

This symbol precedes information about potential equipment damage.



This symbol precedes information about potential personnel hazards.

User Experience Prerequisites

To effectively use the Pneumatic RCS, users should have some experience with pneumatic systems.

Warnings!

READ THIS ENTIRE MANUAL AND ALL RELATED PUBLICATIONS PERTAINING TO THE WORK TO BE PERFORMED BEFORE INSTALLING, OPERATING OR SERVICING THIS EQUIPMENT.

- Follow all appropriate safety codes and standards.
- Failure to follow instructions may result in personal injury and/or property damage.
- Use extreme caution when working around power-input cables. These cables may have potentially lethal or dangerous voltages.
- Prior to energizing the equipment, have qualified personnel verify all wiring and connections against vendor drawings.

PRODUCT DESCRIPTION

The RCS is a Two-Out-Of-Three (2oo3) solenoid operated valve system designed for use as a component in safety instrumented systems. It functions as a redundant pneumatic tripping device to control the pilot air signal to a process valve actuator. The RCS uses 2oo3 voting solenoids to enhance the reliability of the circuit. The RCS consists of three electrically actuated solenoid valves (SOV1, SOV2 & SOV3).

The RCS is available with a NEMA 4, 4x enclosure with terminal strips (2oo3B) or as a stand alone panel mount version without enclosure (2oo3BP).

Under normal operating conditions:

The RCS allows for periodic testing of the solenoids by cycling one solenoid valve and then the other either manually or automati-

Incorrect wiring and/or connections can result in equipment damage or serious system failure. If you have questions or need more information on installing and operating ASCO equipment, contact ASCO.

Avertissements!

LISEZ LE MANUEL COMPLET AINSI QUE LES PUBLICATIONS RELATIVE AU TRAVAIL À EFFECTUER AVANT D'INSTALLER, D'UTILISER OU DE MAINTENIR CET ÉQUIPEMENT.

- Suivez toutes les procédures et normes relatives à la sécurité appropriées.
- Le non-respect des instructions peut entraîner des blessures corporelles et/ou des dommages matériels
- Travaillez avec une extrême précaution à proximité des câbles de puissance. Ces câbles peuvent présenter potentiellement des tensions mortelles ou dangereuses.
- Avant de mettre l'équipement sous tension, faites vérifier le câblage et les connexions par du personnel qualifié par rapport aux plans du fournisseur. Un câblage et/ou des connexions erronée peuvent endommager l'équipement et provoquer une grave défaillance du système. Si vous avez des questions ou avez besoin de plus d'informations sur l'installation et l'utilisation des équipements ASCO, contactez ASCO.

cally therefore attaining the desired safety availability. This testing is performed online without the need for bypassing of the safety action and without interruption of the process.

Normally Closed Construction: The RCS supplies air to the process valve actuator through the "Process" port when energized.

When a trip occurs:

Normally Closed Construction: the RCS blocks the incoming pneumatic signal and connects the "Process" port to the "Exhaust" port. This vents the air signal from the process valve actuator and allows the actuator return spring to move the process to its fail-safe position.

For proper operation, a pneumatic pressure of 0 -150 PSI must be supplied to the RCS INLET connection, and a pressure of 40 -150 psi supplied to the PILOT connection.

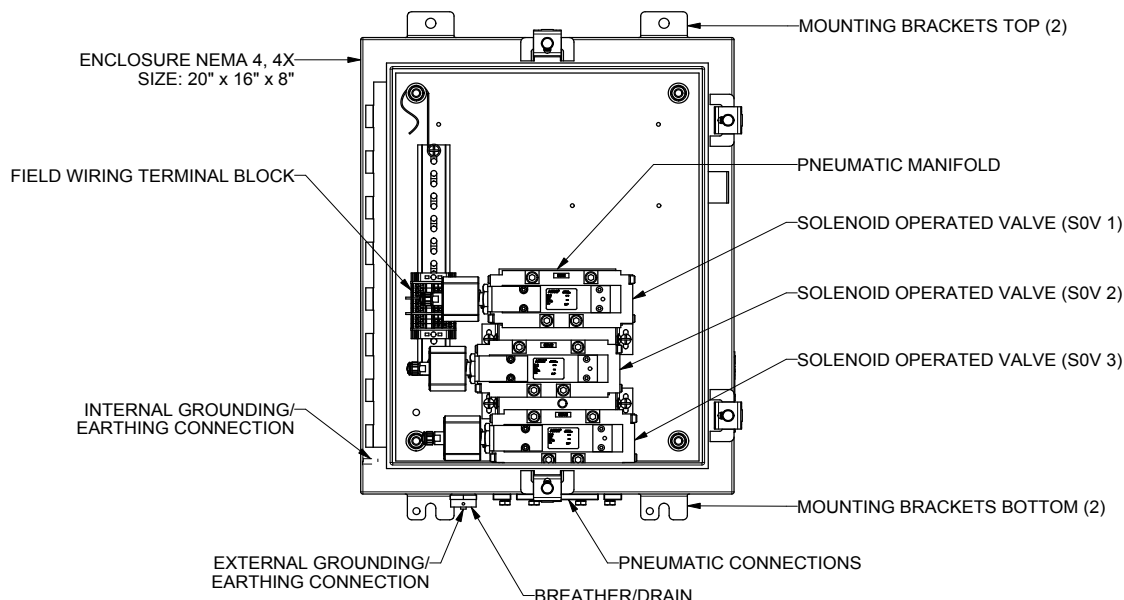

Figure 1A. RCS 2oo3B with Enclosure Components (Approx. Weight 29.5 kg., 65 lbs.)

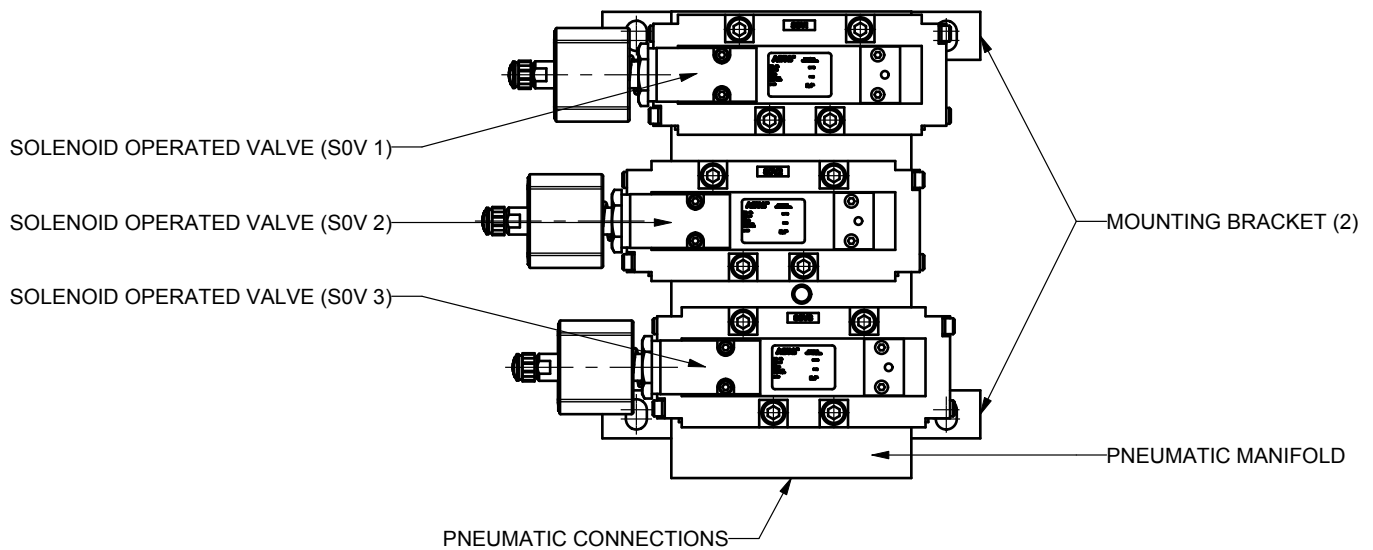

Figure 1B. RCS 2003BP Panel Mount Components (Approx. Weight 9.4 kg., 21 lbs)

GENERAL SPECIFICATIONS

Solenoid Operator:

12, 24, 48 or 120 Volt DC Low Power, Class F coil-1.4 watts.
120/60-110/50 or 230/50-240/50 AC
10.1 Watts, Class H Coil.

Pneumatic Valve:

ISO-3; 5/2 air-spring valve; solenoid operated/Requires external pilot air supply.

Manifold:

3- station ISO base; unique pneumatic circuit design.

Pneumatic Connections:

Pilot:

1/8" NPTF .

Pilot Pressure:

40-150 psi.

Inlet & Process:

1/2" NPTF.

Exhaust Port:

1/2" NPTF.

Inlet Pressure Range:

0 psi to 150 psi.

Air Quality:

Instrument air per ANSI/ISA 7.0.01-1996
Particle size ≤ 40 microns.

Materials:

Enclosure: 2003B

Stainless Steel (304 SS, 316SS) or Fiberglass

Mounting Bracket: 2003BP

Stainless Steel (304SS).

Weight:

2003B: With Enclosure, 29.5 kg. (65 lbs.)
2003BP: Panel Mount, 12.6 kg. (28 lbs.)

Manifold:

Anodized aluminum.

Valves:

Body – Die-cast Aluminum alloy, Sealing-Nitrile (NBR) and Polyurethane (PUR), Spool-Stainless Steel.

Solenoid Coil:

Epoxy encapsulated.

Environmental:

Ambient temperature range:

Consult panel nameplate to verify.
-40 °F to 140 °F (-40 °C to 60 °C).

Approvals:

Exida

Certified SIL 3 capable (Standard Normally Closed construction, see SIL certificate for special constructions).

INSTALLATION

This section provides the information needed to install the RCS.

Unpacking:

Upon receipt of the RCS, unpack it carefully and visually check for damage. The packing list shows the complete model number and describes the features of the unit.

1. If the unit is damaged, immediately contact ASCO.
2. If everything is in order, proceed to the instructions in the following sections.

Mounting Location Considerations:

The RCS is designed to be field mounted near the process valve to be actuated. The following factors should be considered when selecting a mounting location:

- **Accessibility:** Allow ample space for door operation, and for wiring and tubing runs.
- **Temperature:** Consider the amount of heat generated by equipment in the mounting area. The RCS is intended for operation in ambient temperatures from -40 °C to 60 °C (RCS-R)
- **Environment:** Ensure that RCS unit is compatible with respect to water ingress and corrosion resistance.

⚠ WARNING: Explosion Hazard! Do not remove or replace any component while circuit is live unless the area is known to be non-hazardous.

⚠ AVERTISSEMENT: Risque d'explosion. Ne pas retirer ou remplacer les composants lorsque le circuit est sous tension sauf en atmosphère non explosible.

ASCO components are intended to be used only within the technical characteristics as specified on the nameplate. Changes to the equipment are only allowed after consulting the manufacturer or its representative.

Mounting:

The RCS is designed to be mounted using the four mounting brackets provided, as shown in the figure 2A and 2B on the next page. It is recommended that four 3/8" or 10 mm diameter bolts be used.

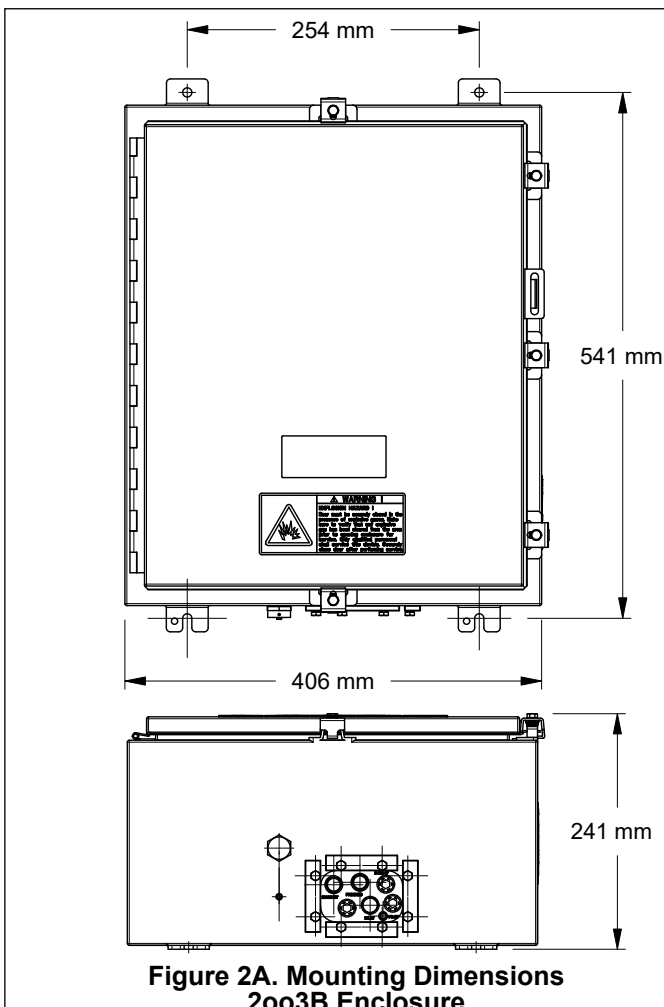

Figure 2A. Mounting Dimensions 2003B Enclosure

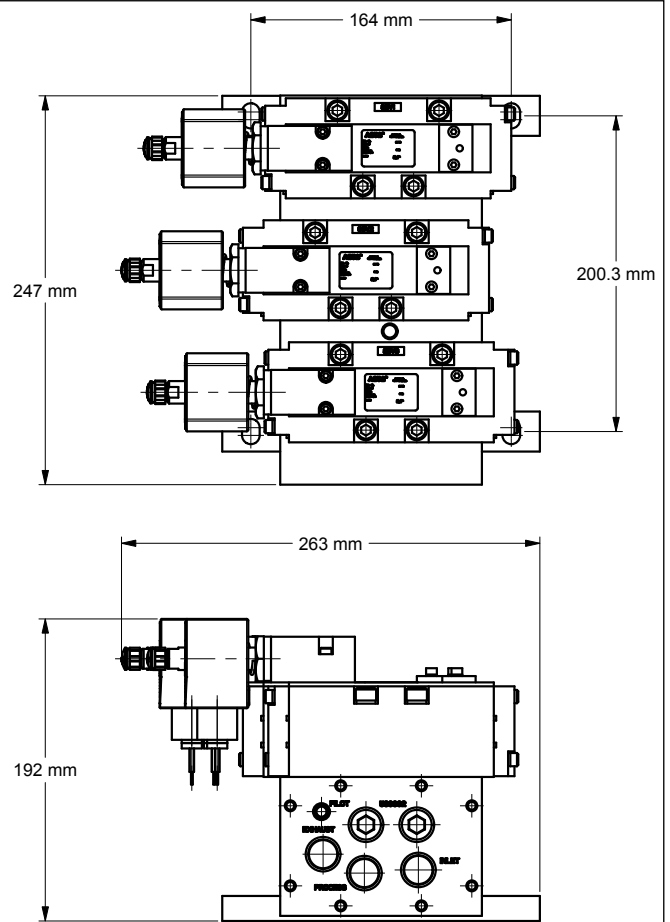

Figure 2B. Mounting Dimensions 2003BP Panel Mount

Field Connections:

Pneumatic Connections (Figure 3A)

⚠ WARNING: Explosion Hazard! Do not remove or replace any component while circuit is live unless the area is known to be nonhazardous.

⚠ AVERTISSEMENT: Risque d'explosion! Ne pas retirer ou remplacer les composants lorsque le circuit est sous tension sauf en atmosphère non explosible.

The RCS should be mounted as closely to the process valve as possible. In order to insure proper operation of the process valve, tubing runs should be as straight and short as possible. Recommended piping for the inlet and outlet pneumatic connections to the RCS is 1/2" stainless steel tubing. Recommended piping for pilot supply is 1/8" stainless steel tubing.

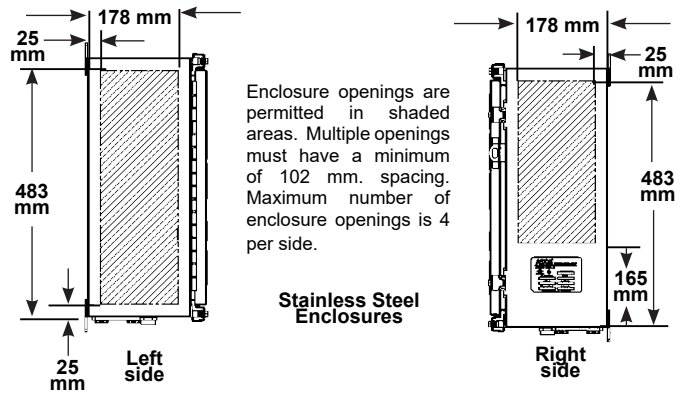

Figure 3B. Enclosure Openings

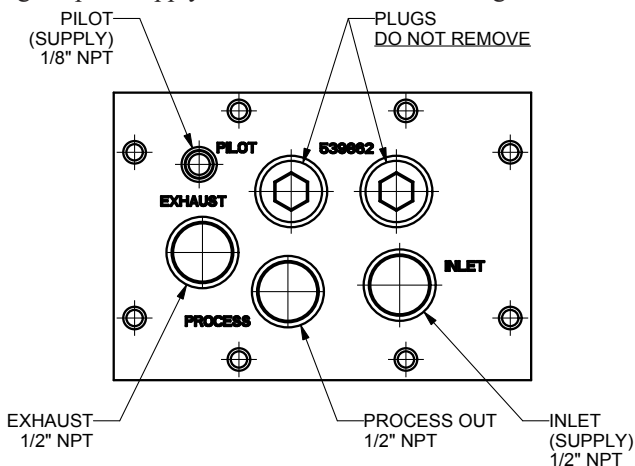

Figure 3A. RCS 2003B/BP Pneumatic Connections

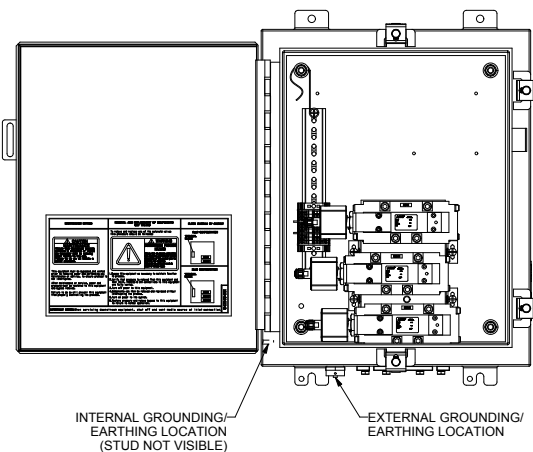

Figure 3C. 2003B Enclosure Grounding Connections

Wiring Guidelines: 2oo3B With Enclosure

The following general guidelines apply to all wiring discussed in this document.

⚠ WARNING: Circuit power must be removed from the device prior to disconnecting the wiring on either the field or internal side of the terminal strip.

⚠ AVERTISSEMENT: L'alimentation électrique du circuit doit être coupée avant de déconnecter le câblage ou le bornier interne de l'équipement.

- Wiring shall be according to the National Electrical Code (ANSI-NFPA 70), Zone 1 ATEX requirements or other applicable codes.
- Wire size: stranded 16 and 18 AWG.
- The terminal clamps are designed for one wire only; DO NOT attempt to terminate multiple wires into one terminal.
- Use care when running signal wiring near to or crossing conduit or wiring that supplies power to motors, solenoids, lighting, horns, bells, etc.
- AC power wiring should be run in a separate conduit from DC power. All power wiring to and from the RCS should be in grounded conduit.

Electrical Connection (Customer Responsibility):

General (Figure 3B)

1. In all cases follow local and national electrical codes and confirm compliance with Zone 1 ATEX requirements.
2. Placement of the conduit connection is up to the customer, in compliance with Zone 1, ATEX requirements, based on location and ease of installation. The upper or lower left side of the box will give the shortest run to the wire terminal.
3. Cable/conduit connections can be added in location as shown on Figure 3B. Entry of external conductors and cables must be through properly installed and suitable certified flameproof cable entry devices and in accordance with ATEX Zone 1 increased safety requirements. Assemble and install cable glands per manufacturer's instructions. Connect cable ground connections to the grounding/ earthing terminal blocks or grounding / earth studs provided internally and externally.
4. It is recommended that standard industry practices are followed to prevent condensation from entering the enclosure and, in some cases of Class I, Div 2 or ATEX Zone 1 conditions, to prevent hazardous gasses and vapours from migrating through the conduit to the control room or open ignition source.

Grounding and Earthing. (Figure 3C)

The RCS should be connected to a high quality instrument grade ground with #14 AWG or heavier wire. A grounding stud is provided both inside and outside the enclosure.

Ground/earth the product in accordance with local and national electric codes as well as ATEX Zone 1 requirements. Green earthing terminal blocks are provided for easy installation of conductor up to 4 mm sq.

Only insert one conductor per terminal block. Grounding studs are provided inside and outside of the enclosure for additional grounding/earthing requirements (See Figure 3C).

RCS-R Base Unit (without on-board PLC)

1. Connect the power source to the designated terminals (SOV1, SOV2) as per wiring diagram provided with the RCS unit. Wiring diagrams are available on the Internet at: www.ascovalve.com/rsconfigurator

Wiring 2oo3BP: Panel Mount

SOV solenoids are equipped with 18 AWG - 18" leads with ground wire and 1/2 NPT female conduit connection for the customer connection.

Section 1. - Normally Closed

1. General Operation and Testing

The RCS is a two-out-of-three (2oo3) voting solenoid operated valve system, designed for use as a component in safety instrumented systems. It functions as a redundant pneumatic tripping device to control the pilot signal to a process valve actuator. All three, or at least two of the three solenoids must be de-energized (De-Energized-To-Trip) in order to move the process valve to its fail safe position.

The RCS allows for periodic testing of the solenoids by cycling one solenoid valve and then the other manually with a customer supplied local initiation of SOV test or automatically by the customers Diagnostic Control System, thereby maintaining the desired safety availability. This testing is performed online without the need for bypassing of the safety action and without interruption of the system process.

Under normal operating conditions, the RCS supplies pilot air to the process valve actuator through the "Process" port of the RCS. When a trip occurs, the RCS blocks the incoming pneumatic signal and connects the "Process" port to the "Exhaust" port. This vents the air signal from the process valve actuator and allows the actuator return spring to move the process valve to its fail safe position.

Reference Table 1: RCS States for the various conditions of supplying or venting the air supply to the process valve, based on the combinations of energizing or de-energizing the solenoid valves SOV1, SOV2 and SOV3.

States	SOV1	SOV2	SOV2	Process/Outlet
1	Energized	Energized	Energized	Air Supply
2	De- Energized	De- Energized	De- Energized	Vented
3	De- Energized	Energized	Energized	Air Supply
4	Energized	De- Energized	Energized	Air Supply
5	Energized	Energized	De- Energized	Air Supply
6	De- Energized	De- Energized	Energized	Vented
7	De- Energized	Energized	De- Energized	Vented
8	Energized	De- Energized	De- Energized	Vented

2. Maintenance: Valve Replacement

⚠ WARNING: Potential Electrostatic Charging Hazard. Use wet or damp cloth when cleaning any non-metallic/painted surfaces.

⚠ AVERTISSEMENT: Risque potentiel de décharge électrostatique. Utilisez un chiffon humide quand vous nettoyez toutes les surfaces non métalliques ou peintes.

⚠ CAUTION: Ensure that the downstream process pressure is maintained or vented as necessary prior to removing power source to the unit. Failure to do so will initiate a power shutdown.

⚠ ATTENTION: Assurez-vous que la pression du processus en aval est maintenue ou purgée au besoin avant de déconnecter l'alimentation de l'équipement. Le non-respect de cette consigne entrainera une coupure d'alimentation.

This equipment must be bypassed and vented prior to removing power and performing any maintenance or service, to ensure process is not interrupted.

After maintenance or service, power and pressure must be restored to this equipment and bypass removed.

Failure to do so will prevent this equipment from properly controlling the process.

The Pneumatic RCS requires no routine maintenance except for periodic inspection for loose wires and fittings. Versions with an enclosure should be opened occasionally and the components checked to make sure they are tight, clean and dry. The Breather Drain should be inspected for obstruction to make sure it is free from debris.

SOV Valve Replacement

⚠ WARNING: DOWNSTREAM PROCESS HAZARD
Ensure that all process connections and equipment are correctly installed downstream of this system prior to servicing this equipment. Failure to do so could result in death or serious injury.

⚠ AVERTISSEMENT: DANGER LIÉ AU PROCESSUS EN AVAL. Assurez vous que toutes les connexions et équipements sont correctement installées en aval de l'équipement avant de réparer ce dernier. Le non-respect de cette consigne pourra entraîner la mort ou des blessures graves.

1. Bypass this equipment as necessary to maintain function to process.
2. Verify that pressure is removed from this equipment and that INLET, PROCESS & EXH connections to this equipment are fully vented.
3. Turn off power to this equipment.
4. Components can then be removed and replaced without interrupting the process. Remove device (coil, solenoid valve) and install the new device following instruction supplied. If replacing a solenoid valve, apply a small amount anti-seize to the screw threads and torque to 160–170 in-lbs., in a criss-cross pattern. Reconnect coil wires to terminal block or power supply.
5. Turn on power to the system.
6. Restore pressure and remove bypass to this equipment to return to normal operation. Verify that each device has power and is in the correct sate (See Table 1).
7. Have the control room run through the programmed test to be sure the system is operating properly.

Section 2.

1. Functional Test Certification

Once assembled and inspected the RCS is cycled through a generic program to validate two-out-of-three (2oo3) shut down function.

2. Spare Parts

⚠ WARNING: Replacement parts are only to be obtained from ASCO or an authorized distributor or the certifications may be invalidated or there may be a risk of explosion.

⚠ AVERTISSEMENT: Le pièces de rechange doivent uniquement être approvisionnées auprès d'ASCO ou d'un de ses distributeurs agréés, sinon les certificats pourraient être invalidés et il pourrait y avoir un risque d'explosion.

VALVES AND COILS			
APPLICATION	VOLTAGE	VALVE	COIL
De-Energize-To-Trip	12/DC	323531	238714-903-D
De-Energize-To-Trip	24/DC	323406	238714-902-D
De-Energize-To-Trip	48/DC	323533	238714-912-D
De-Energize-To-Trip	120/DC	323535	238714-904-D
De-Energize-To-Trip	120/60-110/50	323404	238814-032-D
De-Energize-To-Trip	230/50-240/50	323537	238814-059-D

3. Packaging

While the package for RCS is designed to handle the weight of the unit, there are always hazards in shipping. Upon receipt of product, unpack and check the product against the packing slip. If there is damage to the product, immediately contact the Authorized ASCO sales representative.

4. Disclaimer

Because of the variety of uses for the ASCO Redundant Control System (RCS), the user and those responsible for applying this equipment must satisfy themselves as to the acceptability of the RCS for each application.

The illustrations in this manual are solely intended to illustrate the text of this manual. Because of the many variables and requirements associated with this particular installation, ASCO cannot assume responsibility or liability for actual use based upon the illustrative uses and applications.

In no event will ASCO be responsible or liable for indirect or consequential damages resulting from the use or application of this equipment. ASCO disclaims any implied warranties of merchantability or fitness for a particular purpose.

ASCO DISCLAIMS ANY IMPLIED WARRANTY OR FITNESS FOR A PARTICULAR PURPOSE.

No patent or copyright liability is assumed by ASCO with respect to use of information, circuits, equipment or software described in this text.

Reproduction of the content of this manual, in whole or in part, without written permission from ASCO is prohibited.