

Rosemount™ 3810 Series Liquid Ultrasonic Flow Meters

for 2-Path, 4-Path and 8-Path Extended Temperature Mounting Bracket Meter Electronics

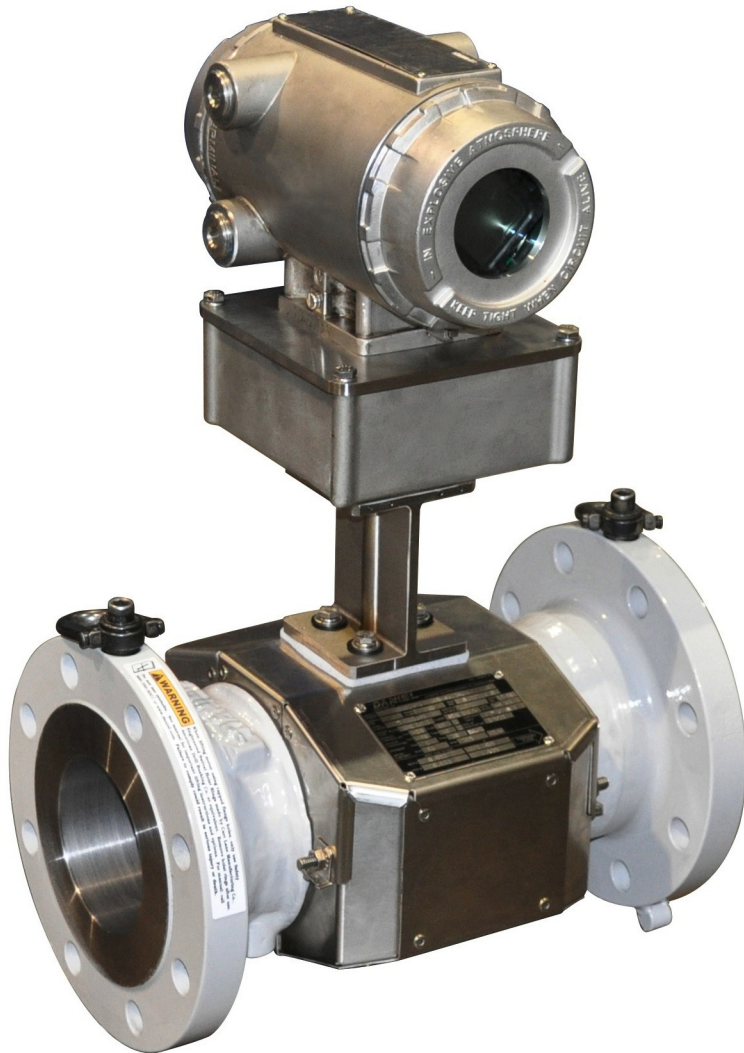

Safety and approval information

This Rosemount product complies with all applicable European directives when properly installed in accordance with the instructions in this manual. Refer to the EU declaration of conformity for directives that apply to this product. The EU declaration of conformity, with all applicable European directives, and the complete ATEX Installation Drawings and Instructions are available on the internet at www.emerson.com or through your local Emerson support center.

Information affixed to equipment that complies with the Pressure Equipment Directive, can be found on the internet at <http://www.emerson.com>.

For hazardous installations in Europe, refer to standard EN 60079-14 if national standards do not apply.

Other information

Full product specifications can be found in the product data sheet. Troubleshooting information can be found in the user manual. Product data sheets and manuals are available from the Emerson website at <http://www.emerson.com>.

Return policy

Follow Emerson procedures when returning equipment. These procedures ensure legal compliance with government transportation agencies and help provide a safe working environment for Emerson employees. Emerson will not accept your returned equipment if you fail to follow Emerson procedures. Return procedures and forms are available on our web support site at www.emerson.com, or by phoning the Emerson Customer Service department.

Emerson Flow customer service

Email:

- Worldwide: [http://flow.support@emerson.com](mailto:flow.support@emerson.com)
- Asia-Pacific: [http://APflow.support@emerson.com](mailto:APflow.support@emerson.com)

Telephone:

North and South America		Europe and Middle East		Asia Pacific	
United States	800 522 6277	U.K.	0870 240 1978	Australia	800 158 727
Canada	+1 303 527 5200	The Netherlands	+31 (0) 704 136 666	New Zealand	099 128 804
Mexico	+41 (0) 41 7686 111	France	0800 917 901	India	800 440 1468
Argentina	+54 11 4837 7000	Germany	0800 182 5347	Pakistan	888 550 2682
Brazil	+55 15 3413 8000	Italy	8008 77334	China	+86 21 2892 9000
		Central & Eastern	+41 (0) 41 7686 111	Japan	+81 3 5769 6803
		Russia/CIS	+7 495 981 9811	South Korea	+82 2 3438 4600
		Egypt	0800 000 0015	Singapore	+65 6 777 8211
		Oman	800 70101	Thailand	001 800 441 6426
		Qatar	431 0044	Malaysia	800 814 008
		Kuwait	663 299 01		
		South Africa	800 991 390		
		Saudi Arabia	800 844 9564		
		UAE	800 0444 0684		

Contents

Preface

Emerson Customer Support
Signal words and symbols
Important safety instructions
Notice
Warranty and Limitations

Section 1: Introduction

1.1	Typical Applications	1
1.2	Features and benefits	2
1.3	Acronyms, abbreviations and definitions	3
1.4	MeterLink software	6
1.5	Rosemount 3810 Series Liquid Ultrasonic Flow Meter design	7
1.5.1	Extended temperature mounting bracket with split shrouds	8
1.5.2	Extended temperature mounting bracket with latched single band shrouds	10
1.5.3	Extended temperature mounting bracket with latched double band shrouds	11
1.5.4	Local display option and glass endcap	14
1.6	Meter specifications	15
1.7	Pre-installation considerations	20
1.8	Safety	20
1.9	Certifications and Approvals	21
1.10	FCC compliance	21

Section 2: Mechanical installation

2.1	Meter components, piping, lifting and mounting	23
2.1.1	Important safety information	23
2.2	Piping recommendations	26
2.3	Safety engineered swivel hoist rings and lifting slings	30
2.4	Use of appropriate safety engineered swivel hoist rings in meter end flanges	31
2.4.1	Safety precautions using safety engineered swivel hoist rings	33
2.4.2	How to obtain safety engineered swivel hoist rings	38
2.4.3	What size safety engineered swivel hoist ring do you need?	39
2.4.4	Appropriately rated lifting slings	40
2.5	Mounting requirements in heated or cooled pipelines	42

Section 3: Electrical installation

3.1	Cable length TTL mode	45
3.2	Cable length Open Collector mode	45
3.3	Grounding meter electronics housing	46
3.4	Conduit seals	47
3.4.1	Startup for systems using explosion-proof conduit.....	48
3.4.2	Startup for systems that use flame-proof cable	51
3.5	Wiring and I/O	52
3.5.1	CPU Module labeling and LED indicators	53
3.6	I/O connections	57
3.6.1	Frequency/Digital outputs	58
3.6.2	Analog input settings	62
3.6.3	Analog output settings	62
3.6.4	Digital Input	62
3.6.5	DHCP server switch settings.....	62
3.6.6	Configuration protect switch settings	63
3.6.7	External power source connection and fuse	63
3.7	Security seal installation	64
3.7.1	Install security seal wires on the Transmitter Electronics Enclosure.....	65
3.7.2	Install security seal wires on the Base Electronics Enclosure.....	67
3.7.3	Install security seal wires on the shrouds	68
3.7.4	Seal conduit ports	74

Section 4: Commission and startup

4.1	Pre-installation considerations	75
4.2	Meter commissioning and startup	76

Section 5: Configuration

5.1	MeterLink setup	77
5.2	Field Setup Wizard	78
5.3	Use AMS Device Manager to configure the meter	82
5.4	Use a Field Communicator to configure the meter	97
5.5	Security seals for the meter	100

Appendix A: Engineering drawings

A.1 Rosemount 3810 Series Liquid Ultrasonic Flow Meter drawings 101

Appendix B: Write-protected configuration parameters

B.1 Write-protected configuration..... 103

Appendix C: Open source licenses

C.1 GNU General Public License 106
C.2 GNU Lesser General Public License..... 117
C.3 BSD Open Source License 121
C.4 M.I.T License 122
C.5 Zlib License 123

Appendix D: Index

D.1 Manual Index..... 125

List of Tables

Table 1-1	Acronyms, abbreviations and definitions	3
Table 1-2	Ultrasonic Meter shrouds options per ASME pressure rating.....	8
Table 1-3	Liquid Ultrasonic Flow Meter specifications	15
Table 2-1	Piping recommendation for uni-directional or bi-directional flow	29
Table 2-2	Hoist ring part number lookup table	38
Table 2-3	Hoist ring lookup table for Rosemount Model Liquid Ultrasonic Flow Meters.....	39
Table 2-4	Transducer operating temperature ranges.....	43
Table 3-1	Configurations for open collector frequency outputs	45
Table 3-2	CPU Module labeling and LED functions	54
Table 3-3	Ethernet cable to PC communication	55
Table 3-4	Serial Port A parameters.....	56
Table 3-5	Frequency/Digital Outputs possible configurations.....	60
Table 3-6	DHCP server switch settings.....	62
Table 3-7	Configuration protect switch settings	63
Table 3-8	installing wire seals on the meter	64
Table 5-1	Local display labels, descriptions and valid units.....	79
Table B-1	Write-protected configuration parameters.....	103
Table C-1	Open source licences	105

List of Figures

Figure 1-1	MeterLink download and registration	6
Figure 1-2	Extended temperature mounting bracket, split shroud and local display meter design	9
Figure 1-3	Extended temperature mounting bracket, latched single band shroud and local display design.....	10
Figure 1-4	Extended temperature mounting bracket, latched double band shrouds and local display design.....	11
Figure 1-5	Dual Extended temperature mounting bracket, latched double band shrouds and local display meter design	12
Figure 1-6	Dual extended temperature mounting bracket, latched double band shrouds, Techlok, weld bevel ends with cradles and local display meter design	13
Figure 1-7	Optional local display and glass endcap	14
Figure 1-8	Rosemount 3810 Series Liquid Ultrasonic Meter ATEX approval	20
Figure 2-3	Piping recommendations unidirectional flow	27
Figure 2-4	Piping recommendations bidirectional flow	28
Figure 2-5	Meter end flange with tapped flat-counterbore hole for hoist ring	31
Figure 2-6	Safety engineered hoist ring and non-compliant eye bolt	32
Figure 2-7	90 Degree angle between slings	34
Figure 2-8	3818 meter with Techlok ends and cradle	35
Figure 2-9	Sling contacting electronics enclosure	36
Figure 2-10	Correct sling attachment.....	40
Figure 2-11	Incorrect sling attachment	41
Figure 3-1	Transmitter Electronics Enclosure internal chassis ground.....	46
Figure 3-2	External ground lug	47
Figure 3-3	Transmitter electronics enclosure wiring	49
Figure 3-4	CPU Module labeling and LED indicators.....	53
Figure 3-5	PC to meter serial connection wiring	57
Figure 3-6	CPU Module I/O connections.....	57
Figure 3-7	CPU Module - Frequency/Digital outputs common ground	61
Figure 3-8	CPU Module power source connections	63
Figure 3-9	Transmitter electronics enclosure security latch	65
Figure 3-10	Transmitter Electronics Enclosure security seals	66
Figure 3-11	Base Enclosure security seals	67
Figure 3-12	Split shroud security seals	69

Figure 3-13	Latched single band shroud assembly	70
Figure 3-14	Liquid Ultrasonic Flow Meter assembly with latched double band shrouds	71
Figure 3-15	Liquid Ultrasonic Flow Meter assembly with latched double band shrouds	72
Figure 3-16	Shroud latch holes for security wire seals	73
Figure 5-1	AMS Device Description search.....	82
Figure 5-2	AMS file download complete	83
Figure 5-3	AMS Device Manager	84
Figure 5-4	AMS Device Manager - Overview	84
Figure 5-5	AMS Device Manager - Guided Setup	85
Figure 5-6	AMS Device Manager - Service Tools All Variables status indicators.....	87
Figure 5-7	Display Meter K-Factors	87
Figure 5-8	AMS Device Manager - Configure Manual Setup	88
Figure 5-9	Gating configuration parameter Edge gated, active high	90
Figure 5-10	Gating configuration parameter Edge gated, active low	90
Figure 5-11	Gating configuration parameter State gated, active high	90
Figure 5-12	Gating configuration parameter State gated, active low	91
Figure 5-13	Configure Flow Analysis Alert	91
Figure 5-14	AMS Device Manager - Service Tools Alerts	93
Figure 5-15	Configuration changes dialog	93
Figure 5-16	AMS Device Manager - Service Tools	94
Figure 5-17	AMS Device Manager - Service Tools All Variables	95
Figure 5-18	AMS Device Manager - Service Tools Trends	96
Figure 5-19	Transmitter field wiring conduit entries	98
Figure 5-20	Field Communicator wiring diagram for the 3810 Series electronics	99

Section 1: Introduction

Rosemount 3810 Series Liquid Ultrasonic Flow Meters with the extended temperature mounting bracket and dual extended mounting bracket option and various configurations, meet a broad range of customer requirements. Each meter comes fully assembled from Emerson and all parts and assemblies are tested prior to shipment. Refer to the following documents for additional details:

- 00825-0400-3240 HART® Field Device Specification for Liquid Ultrasonic Flow Meters
- 00809-0100-7630 MeterLink Software for Rosemount™ Gas and Liquid Ultrasonic Flow Meters
- The Rosemount 3810 Series Liquid Ultrasonic Flow Meter technology can be applied to flow meter measurement applications as shown below.

1.1

- Allocation measurement
- Check metering
- Leak detection
- Line balancing
- Batch control
- Loading and off loading
- Offshore
 - FPSO (Floating Production, Storage and Offshore Loading)
 - Offshore Platforms
 - Barges
- Pipelines
 - Crude Oil pipelines
 - Refined product pipelines
- Terminals
 - Loading and off-loading (Ship, barge, truck, railcar, etc...)
 - Tank Farms
- Cavern Storage

1.2 Features and benefits

- Explosion-proof transmitter electronics enclosure with CPU Module, Power Supply, Intrinsic Safety Barrier Module
- Intrinsically safe transducer electronics enclosure with the Acquisition Module
- MeterLink (software for Rosemount™ Ultrasonic Flow Meters)
- HART® and AMS Suite: Intelligent Device Manager communications for PlantWeb™ architecture
- Extended temperature mounting bracket options
- Reduce unaccounted measurement
- Increase energy savings
- Replaceable transducers while under pressure
- Extensive self diagnostics
- Immediate alarm reporting
- Auto-detected ASCII/RTU Modbus communications protocol
- Interchangeable electronics modules
- Internet-ready communications
- Ethernet access
- Modbus TCP/IP
- On-board LED status indicators
- Analog pressure and temperature inputs
- Local display and glass endcap (optional)
- Extended temperature mounting bracket for high process temperature applications

For other features and benefits refer to the product datasheet from:

<http://www2.emersonprocess.com/EN-US/BRANDS/EMERSON/FLOW/Pages/Flow.aspx>

1.3 Acronyms, abbreviations and definitions

Table 1-1 Acronyms, abbreviations and definitions

Acronym or abbreviation	Definition
°	degree (angle)
°C	degrees celsius (temperature unit)
°F	degrees fahrenheit (temperature unit)
ADC	analog-to-digital converter
AI	analog input
AMS® Device Manager	Asset Management Software - Device Manager
AO	analog output
ASCII MODBUS	A Modbus protocol message framing format in which ASCII characters are used to delineate the beginning and end of the frame. ASCII stands for American Standard Code for Information Interchange.
boolean	a type of data point that can only take on values of TRUE or FALSE (generally TRUE is represented by a value of 1, FALSE is represented by a value of 0)
bps	bits per second (baud rate)
cPoise	centipoise (viscosity unit)
CPU	central processing unit
CTS	Clear-to-Send; the RS-232C handshaking signal input to a transmitter indicating that it is okay to transmit data — i.e., the corresponding receiver is ready to receive data. Generally, the Request-to-Send (RTS) output from a receiver is input to the Clear-to-Send (CTS) input of a transmitter.
DAC	Digital-to-Analog Converter
MeterLink™	Rosemount™ Ultrasonic meter interface software
DI	digital input
Direct Mount	Transmitter electronics enclosure and base electronics enclosure is directly mounted to meter body
DO	digital output
DHCP	Dynamic Host Configuration Protocol
dm	decimeter (10^{-1} meters, length unit)
ECC	Error Correction Code
EEPROM	Electrically-Erasable, Programmable Read-Only Memory
Flash	non-volatile, programmable read-only memory
FODO	output that is user configurable as either a frequency or digital output
HART® Communication Protocol	Highway Addressable Remote Transducer communications protocol
hr	hour (time unit)
Hz	Hertz (cycles per second, frequency unit)
I/O	Input/Output
IS	Intrinsically Safe

Table 1-1 Acronyms, abbreviations and definitions

Acronym or abbreviation	Definition
K	Kelvin (temperature unit)
kHz	kilohertz (10^3 cycles per second, frequency unit)
LAN	Local Area Network
LED	light-emitting diode
m	meter (length unit)
m ³ /d	cubic meters per day (volumetric flow rate)
m ³ /h	cubic meters per hour (volumetric flow rate)
m ³ /s	cubic meters per second (volumetric flow rate)
mA	milliamp (current unit)
MAC Address	Media Access Control (Ethernet Hardware Address -EHA)
microinch (μinch)	microinch (10^{-6} in)
micron	micrometer (10^{-6} m)
MMU	Memory Management Unit
MPa	Megapascal (equivalent to 10^6 Pascal) (pressure unit)
N/A	not applicable
Nm ³ /h	normal cubic meters per hour
NOVRAM	non-volatile random access memory
Pa	Pascal, equivalent to 1 newton per square meter (pressure unit)
Pa·s	Pascal Second (viscosity unit)
PC	Personal Computer
PFC	peripheral field connection (board)
P/N	part number
PS	power supply (board)
psi	pounds per square inch (pressure unit)
psia	pounds per square inch absolute (pressure unit)
psig	pounds per square inch gage (pressure unit)
R	Radius
rad	radian (angle)
RAM	Random Access Memory

Table 1-1 Acronyms, abbreviations and definitions

Acronym or abbreviation	Definition
Remote Mount Option	Detaching the transmitter electronics enclosure and base electronics enclosure from meter body and mounting and affixing them with the mounting bracket to a pole or other structure.
RTS	Request-to-Send; the RS-232C handshaking signal output by a receiver when it is ready to receive data
RTU MODBUS	A Modbus protocol framing format in which elapsed time between received characters is used to separate messages. RTU stands for Remote Terminal Unit.
s	second (time unit, metric)
SDRAM	Synchronous Dynamic Random Access Memory
sec	second (time unit, U.S. Customary)
TCP/IP	Transmission Control Protocol/Internet Protocol
time_t	seconds since Epoch (00:00:00 UTC Jan. 1, 1970) (time unit)
UDP	User Datagram Protocol
U.L.	Underwriters Laboratories, Inc., product safety testing and certification organization
V	volts (electric potential unit)
W	watts (power unit)

1.4 MeterLink software

MeterLink software has robust features for setting communications parameters, calibrating your meter, collecting logs and reports and monitoring the meter health and alarm statuses. MeterLink may be downloaded at no charge from:

<http://www2.emersonprocess.com/en-US/brands/emerson/Flow/ultrasonics/Pages/MeterLink.aspx>

Figure 1-1 MeterLink download and registration



United States

MeterLink 1.10, diagnostic software for ultrasonic meters. April 2013

No charge

Diagnostic and monitoring software providing enhanced reliability and functionality for the 3400, 3410, 3800 and 3810 Daniel Ultrasonic Flow Transmitters.

Daniel's new MeterLink software gives users access to information not seen before. And not simply more data, but actionable, critical information presented in an intuitive graphical format that takes complexity out of your flow measurement. Delivered to the right person at the right time, this information will empower your staff to work predictively, instead of reactively.

[See more information on our products page](#)

1. From the right panel under Quick Links, click the **MeterLink Registration and Download** link.
2. Click **Order Now** to complete the Online registration form.
3. Click **Next** to go to the order confirmation page.
4. Click **Complete Order**.
You will receive a conformation email with a hyperlink directing you to the download site. Click the link provided.
5. Click **Save**.

Refer to the *MeterLink Software for Gas and Liquid Ultrasonic Meters Quick Start Manual* (00809-0100-7630) for installation instructions and setup for initial communications. You may download the manual from the MeterLink web page:

<http://www2.emersonprocess.com/en-US/brands/emerson/Flow/ultrasonics/Pages/MeterLink.aspx>

1.5 Rosemount 3810 Series Liquid Ultrasonic Flow Meter design

The Rosemount 3810 Liquid Ultrasonic Flow Meter with the extended temperature mounting bracket design includes the split (clam shell) shroud, latched single band shroud and latched double band shroud covers protecting the transducers and cable assemblies. The installed shroud option depends on the outside diameter of the meter.

The Rosemount 3810 Series Liquid Ultrasonic Flow Meter is designed as a 3812, 2-path (four transducers), 3814, 4-Path (eight transducers) or 3818, 8-Path (sixteen transducers) in-line meter designed to measure the difference in signal transit time with and against the flow across one or more measurement path(s). A signal transmitted in the flow direction travels faster than one transmitted against the flow direction. Each measurement path is defined by a transducer pair in which each transducer alternately acts as transmitter and receiver. The meter uses transit time measurements and transducer location information to calculate the mean velocity.

Computer simulations of various velocity profiles demonstrate that multiple measurement paths provide an optimum solution for measuring asymmetric flow. The Rosemount 3810 Liquid Ultrasonic Flow Meter utilizes two cross-bore, parallel-plane measurement paths, offers a high degree of repeatability, bi-directional measurement and superior low-flow capabilities without the compromises associated with conventional technologies.

The Rosemount 3810 Series Liquid Ultrasonic Flow Meter's U.L. safety listing is accomplished through the combination of an explosion-proof Transmitter Electronics Enclosure that houses the 3810 Series CPU Module, Power Supply board, I.S. Barrier board, Backplane board and optional LCD Display board.

The Base Electronics Enclosure is intrinsically safe and houses the Acquisition Module, the acquisition cable and wiring. The Intrinsically safe transducers and cable assemblies are designed for Class 1, Division 1, Groups C and D areas without need of further protection when installed in accordance with the field wiring diagram (refer to Rosemount drawing DMC - 004936, see [Appendix A](#) and [Section 1.8](#)).

See [Table 1-2](#) for ultrasonic meter sizes and AMSE ratings. See the list below for meter body shroud types.

Meter options are:

- split shroud ([Figure 1-2](#))
- latched single band shroud ([Figure 1-3](#))
- latched double band shrouds ([Figure 1-4](#))
- Dual extend bracket, latched double band shrouds ([Figure 1-5](#))
- Dual extended temperature mounting bracket, latched double band shrouds, Techlok, weld bevel ends with cradles ([Figure 1-6](#))

1.5.1 Extended temperature mounting bracket with split shrouds

Rosemount™ Liquid Ultrasonic Flow Meters are assembled, configured, and tested at the factory. The meter components include the transmitter electronics enclosure, the base electronics enclosure, the meter body with shroud covers for the transducers and cable assemblies and optional one or two base and transmitter electronics enclosure extended temperature mounting bracket. The extended temperature mounting bracket design is used to provide a buffer between the meter electronics and the meter body for higher or lower than the temperature limit of the electronics.

The Rosemount 3812 Liquid Ultrasonic Flow Meters with split shrouds and flange stabilizers are available for 4” to 10” cast meters

The 3812 Liquid Ultrasonic 2-Path Flow Meter, 4” to 10” meter sizes up to ASME 600 rating have the split shroud design option as shown in [Figure 1-2](#). All other meter designs use band shrouds.

Table 1-2 Ultrasonic Meter shrouds options per ASME pressure rating

Meter size and type	ASME rating	Shroud type
2” - 3” forged body	150, 300, 600, 900 and 1500	Latched single band shroud
4” - 10” cast body	150, 300, 600	Split shroud
4” to 10” forged body	150, 300, 600, 900, 1500 and 2500	Latched single band shroud
12” and larger forged bodies	150, 300, 600, 900, 1500 and 2500	Latched double band shroud

Figure 1-2 Extended temperature mounting bracket, split shroud and local display meter design

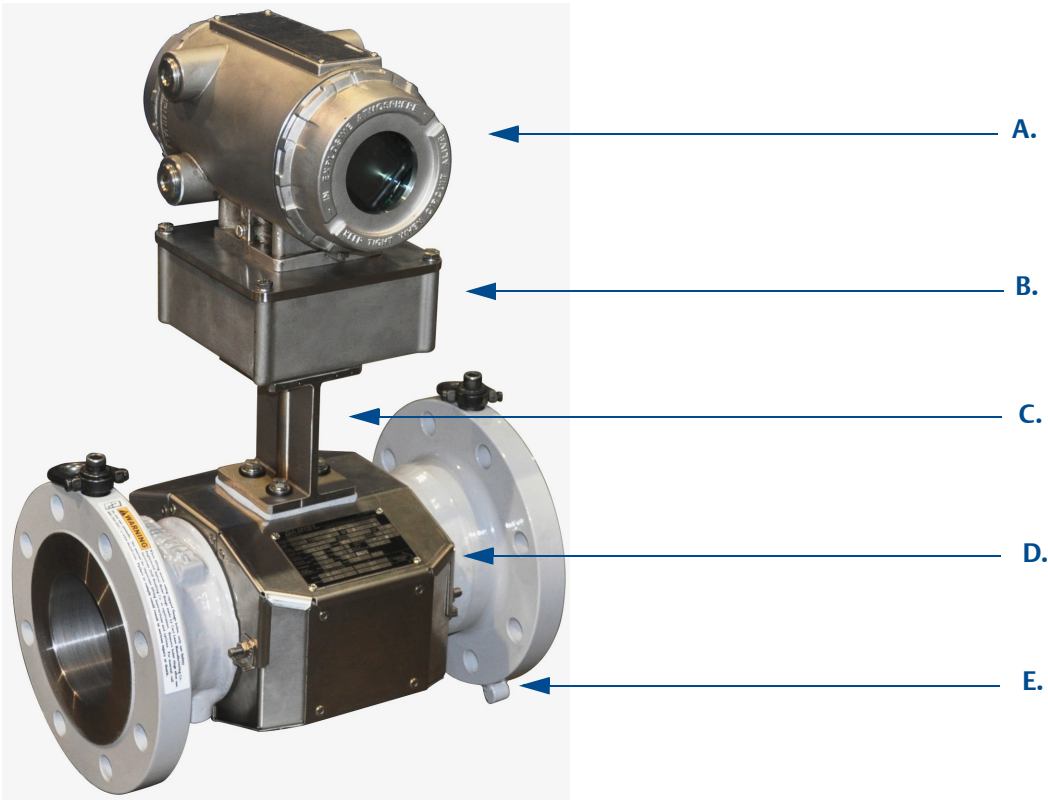

- A. Explosion-proof transmitter enclosure (3810 Series CPU Module, Power Supply, I.S. Barrier Board, Backplane Board and optional LCD Board with glass endcap)
- B. Intrinsically-safe base enclosure includes Acquisition Module
- C. Extended temperature mounting bracket
- D. Meter body and split shroud cover for transducers and cables assemblies
- E. Stabilizer

1.5.2 Extended temperature mounting bracket with latched single band shrouds

Rosemount 3812 Liquid Ultrasonic Flow Meters with the latched single band shrouds and flange feet are one piece shrouds. One or two single band shrouds may be installed on a meter.

Figure 1-3 Extended temperature mounting bracket, latched single band shroud and local display design

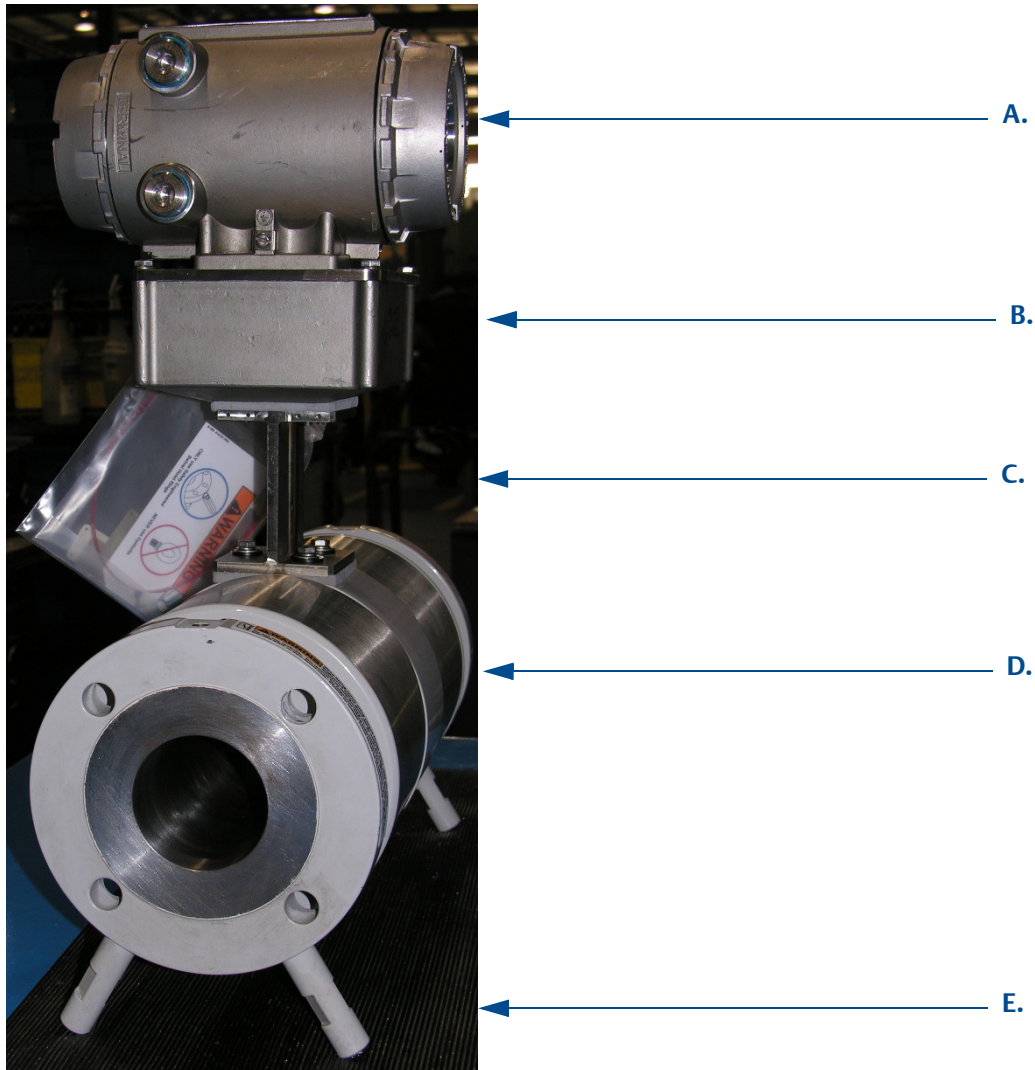

- A. Explosion-proof transmitter enclosure (3810 Series CPU Module, Power Supply, I.S. Barrier Board, Backplane Board and optional LCD Board with glass endcap)
- B. Intrinsically-safe base enclosure includes Acquisition Module
- C. Extended temperature mounting bracket
- D. Meter body with two latched band shrouds covering transducers and cables assemblies
- E. Screwed feet

1.5.3 Extended temperature mounting bracket with latched double band shrouds

The Rosemount 3810 Series Liquid Ultrasonic Flow Meter design with extended temperature mounting bracket, latched double band shrouds and local display is shown in Figure 1-4 is available for 3812, 2-Path meters and 3814, 4-Path meters. Double band shrouds have two parts joined by a hem bend joint. One or two double band shrouds may be installed on a meter.

Figure 1-4 Extended temperature mounting bracket, latched double band shrouds and local display design

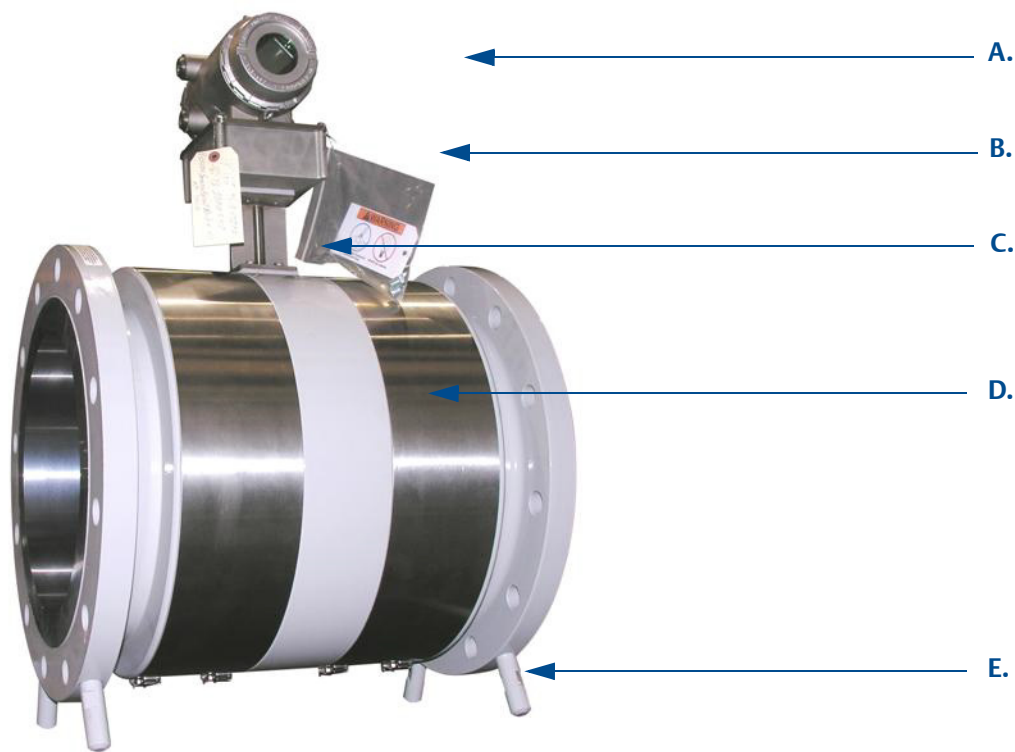

- A. Explosion-proof transmitter enclosure (3810 Series CPU Module, Power Supply, I.S. Barrier Board, Backplane Board and optional LCD Board with glass endcap)
- B. Intrinsically-safe base enclosure includes Acquisition Module
- C. Extended temperature mounting bracket
- D. Meter body with two latched double band shrouds covering transducers and cables assemblies
- E. Screwed feet

The Rosemount 3810 Series Liquid Ultrasonic Flow Meter design with dual extended temperature mounting bracket, latched double band shrouds and local display is shown in Figure 1-5 is available for 3818, 8-Path meters.

Figure 1-5 Dual Extended temperature mounting bracket, latched double band shrouds and local display meter design

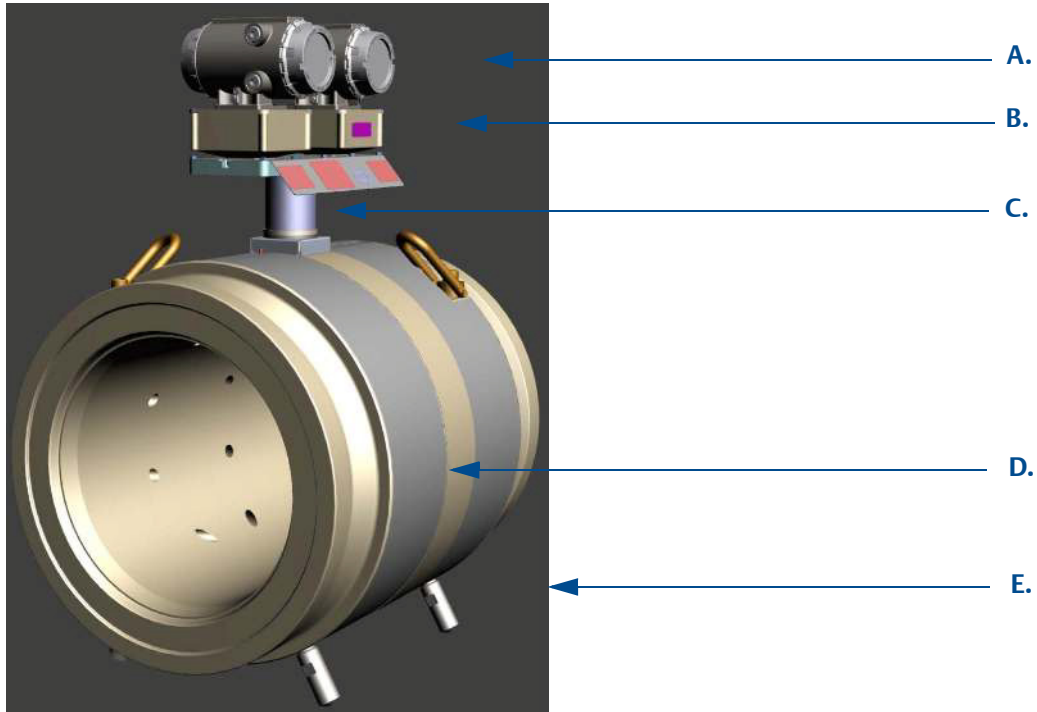

- A. Two explosion-proof transmitter enclosures (3810 Series CPU Module, Power Supply, I.S. Barrier Board, Backplane Board and optional LCD Board with glass endcap)
- B. Two intrinsically-safe base enclosures includes Acquisition Module
- C. Extended temperature mounting bracket
- D. Meter body and two latched double shrouds covering transducers and cables assemblies
- E. Screwed feet

The 3818 Liquid Ultrasonic meter design with dual extended temperature mounting bracket, Techlok weld bevel ends with lifting cradles and hoist rings, latched double band shrouds and local display is shown in Figure 1-6.

Figure 1-6 Dual extended temperature mounting bracket, latched double band shrouds, Techlok, weld bevel ends with cradles and local display meter design

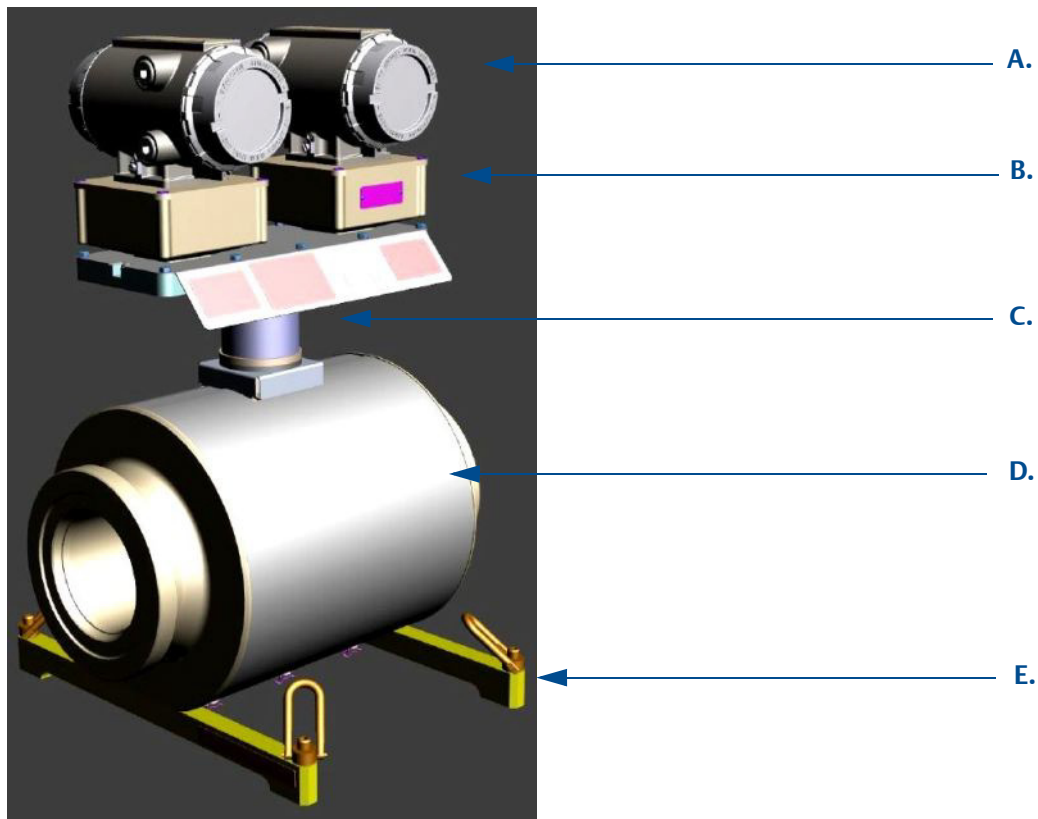

- A. Explosion-proof transmitter enclosure (3810 Series CPU Module, Power Supply, I.S. Barrier Board, Backplane Board and optional LCD Board with glass endcap)
- B. Intrinsically-safe base enclosure includes Acquisition Module
- C. Dual extended temperature mounting bracket and label bracket
- D. Meter body and latched double band shrouds covering transducers and cables assemblies
- E. Lifting cradles with hoist rings

1.5.4 Local display option and glass endcap

Rosemount 3810 Series Liquid Ultrasonic Meters have an optional LED Local Display and glass endcap. The LCD Module is connected to J8 on the Field Connector Board.

Figure 1-7 Optional local display and glass endcap

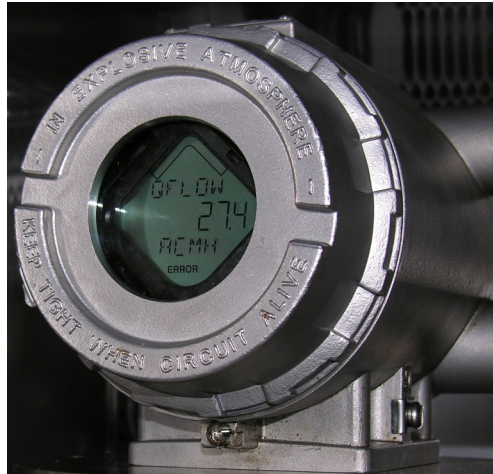

NOTE: The optional LCD Display requires firmware v1.04 and Uboot version, January 31, 2013 or higher.

1.6 Meter specifications

CAUTION

ESCAPING FLUIDS HAZARD

The purchaser of the meter is responsible for the selection of Rosemount components/seals and materials compatible with the chemical properties of the measurement fluid.

Failure to select suitable meter components/seals may cause escaping fluids, resulting in injury or equipment damage.

Consult your Emerson Flow Service representative to ensure you purchase the correct components and seals for your application. See [Table 1-3](#) for the 3810 Series Liquid Ultrasonic Flow Meter specifications.

Table 1-3 Liquid Ultrasonic Flow Meter specifications

Liquid Ultrasonic Flow Meter specifications	
Meter type	Number of paths <ul style="list-style-type: none">• 3812 - Two path (four transducer) chordal design• 3814 - Four path (eight transducers)• 3818 - Eight path (sixteen transducers)
	Ultrasonic type <ul style="list-style-type: none">• Transit-time based measurement• Spool piece with integral mount transducers

Table 1-3 Liquid Ultrasonic Flow Meter specifications

Meter Performance	
Linearity	<ul style="list-style-type: none"> ± 0.30% of measured value over a 10:1 turndown (40 to 4 ft/s; 12.2 to 1.2 m/s)
Repeatability	<ul style="list-style-type: none"> ±0.10% of reading in the specified velocity range
Velocity range	<ul style="list-style-type: none"> 40.0 ft/s (12.2 m/s) (nominal) to 2.0 ft/s (0.6 m/s) 48 fps (14.3 m/s) (over-range)
Body and Flange Pressure rating range	<p>U.S. Customary Units sizes - 2, 3, 4, 6, 8, 10, 12, 14, 16, 18, 20, 24, 28, 30, and 36 (in)</p> <ul style="list-style-type: none"> ASME pressure rating 150 and 300, 600, 900, 1500 Carbon Steel 316 Stainless Steel <p>Metric Units sizes</p> <ul style="list-style-type: none"> DN 50, 75, 100, 150, 200, 250, 300, 350, 400, 450, 500, 600, 700, 750, and 900 PN 20, 50, 100, 150, 200 Carbon Steel 316 Stainless Steel <p>Meter bore</p> <ul style="list-style-type: none"> Schedule 40 and Schedule 80 <p>Maximum Pressures</p> <ul style="list-style-type: none"> Dependent on operating temperature
Flange types	<p>ASME rating - 150, 300, 600, 900 and 1500</p> <ul style="list-style-type: none"> Raised face or RTJ
Specific Gravity	0.35 to 1.50
Accuracy Limits	<p>Accuracy limits typically are:</p> <ul style="list-style-type: none"> ± 2% without a flow calibration, ± 0.3% with flow calibration
Minimum operating pressure	<ul style="list-style-type: none"> 0 psig; 0 barg
Electronic specifications	
Power	<p>Meter</p> <ul style="list-style-type: none"> 10.4 VDC to 36 VDC measured at the meter terminals¹ 11 W maximum power consumption <p>Serial cable</p> <ul style="list-style-type: none"> Belden #9940 or equivalent (22 gauge) <ul style="list-style-type: none"> Capacitance (pF/m) 121.397 (conductor to conductor) Capacitance (pF/m) 219.827 (conductor to other conductor and shield) Resistance (DC) DCR @ 20 °C (Ohm/km) 48.2307 Nominal Outer shield resistance - DCR @ 20°C (Ohm/km) 16.405 Operating voltage - 300 V RMS (UL AWM Style 2464) Current 2.4 Amps per conductor @ 25°C (recommended) <p>Ethernet cable</p> <ul style="list-style-type: none"> Cat-5 Standard 100Mbps <p>Frequency (see Table 3-1)</p> <ul style="list-style-type: none"> 22 AWG wire characteristics are as follows: <ul style="list-style-type: none"> Capacitance = 20 pF/ft or 20 nF/1000 ft (between two wires) Resistance = 0.0168 Ohms/ft or 16.8 Ohms/1000 ft Pull-up voltage is 24 VDC
Temperature flameproof transmitter electronic enclosure and base electronic enclosure	<ul style="list-style-type: none"> Ambient: -40 °F to 140 °F (-40 °C to 60 °C) Storage: -58 °F to 185 °F (-50 °C to 85 °C) <p>Note: The transmitter electronics enclosure and base enclosure must be remote mounted or have the extended temperature mounting bracket option if the operating temperature exceeds 140 °F (60 °C).</p>

Table 1-3 Liquid Ultrasonic Flow Meter specifications

Electronic specifications (continued)	
Transducers Operating temperature range	<ul style="list-style-type: none"> • LT-10 Operating temperature range: <ul style="list-style-type: none"> – LT-10 (-50 °C to 135 °C) (-58 °F to 275 °F) w/ NBR O-rings, 316 Housings – LT-10 (-40 °C to 150 °C) (-40 °F to 302 °F) w/ FKM O-rings, 316 Housings – LT-10 (-50 °C to 135 °C) (-58 °F to 275 °F) w/ NBR O-rings, Inconel Housings – LT-10 (-40 °C to 150 °C) (-40 °F to 302 °F) w/ FKM O-rings, Inconel Housings) • LT-11 Operating temperature range: <ul style="list-style-type: none"> – LT-11 (-50 °C to 135 °C) (-58 °F to 275 °F) w/ NBR O-rings, 316 Housings – LT-11 (-40 °C to 150 °C) (-14 °F to 302 °F) w/ FKM O-rings, 316 Housings – LT-11 (-50 °C to 135 °C) (-58 °F to 275 °F) w/ NBR O-rings, Inconel Housings – LT-11 (-40 °C to 150 °C) (-14 °F to 302 °F) w/ FKM O-rings, Inconel Housings • LT-14 Operating temperature <ul style="list-style-type: none"> – LT-14 (-50 °C to 135 °C) (-58 °F to 275 °F) w/NBR O-rings, 316 Housings – LT-14 (-40 °C to 175 °C) (-40 °F to 347 °F) w/FKM O-rings, 316 Housings – LT-14 (-50 °C to 135 °C) (-58 °F to 275 °F) w/NBR O-rings, Inconel Housings – LT-14 (-40 °C to 175 °C) (-40 °F to 347 °F) w/FKM O-rings, Inconel Housings • LT-15 Operating temperature <ul style="list-style-type: none"> – LT-15 (-50 °C to 135 °C) (-58 °F to 275 °F) w/NBR O-rings,316 Housings – LT-15 (-40 °C to 175 °C) (-40 °F to 347 °F) w/FKM O-rings, 316 Housings – LT-15 (-50 °C to 135 °C) (-58 °F to 275 °F) w/ NBR O-rings, Inconel Housings – LT-15 (-40 °C to 175 °C) (-40 °F to 347 °F) w/ FKM O-rings, Inconel Housings • LT-16 Operating temperature range <ul style="list-style-type: none"> – LT-16 (-50 °C to 135 °C) (-58 °F to 275 °F) w/ NBR O-rings, 316 Housings – LT-16 (-40 °C to 175 °C) (-40 °F to 347 °F) w/ FKM O-rings, 316 Housings – LT-16 (-50 °C to 135 °C) (-58 °F to 275 °F) w/ NBR O-rings, Inconel Housings – LT-16 (-40 °C to 175 °C) (-40 °F to 347 °F) w/ FKM O-rings, Inconel Housings) • LT-17 Operating temperature range <ul style="list-style-type: none"> – LT-17 (-50 °C to 135 °C) (-58 °F to 275 °F) w/ NBR O-rings, 316 Housings – LT-17 (-40 °C to 175 °C) (-14 °F to 347 °F) w/ FKM O-rings, 316 Housings – LT-17 (-50 °C to 135 °C) (-58 °F to 275 °F) w/ NBR O-rings, Inconel Housings – LT-17 (-40 °C to 175 °C) (-14 °F to 347 °F) w/ FKM O-rings, Inconel Housings <p>Note: The process temperature must not exceed the operating temperature range of the transducers.</p> <p>Note: LT-10 and LT-16 transducers are designed for 4 inch to 10 inch meters. LT-11 and LT-17 transducers are designed for 12 inch and larger meters.</p> <p>Note: The LT-14 transducer is used on the 2", 3812 ASME 1500 ultrasonic meter and the LT-15 is used on 12" to 24" meters.</p> <p>Note: The ultrasonic transducers are not intended for use across boundary walls of different hazardous area classifications. The transmitter electronics cannot be remote mounted from a Division 1 classification to a Division 2 area to meet an area classification.</p>
Acquisition Cable	<ul style="list-style-type: none"> • Total cable length between the Acquisition Module and ultrasonic transducers must not exceed 15 feet (4.7 meters) when using the extended temperature mounting bracket option.

Table 1-3 Liquid Ultrasonic Flow Meter specifications

Communications specifications	
Connectivity protocols	One serial RS-232/RS-485 port (115 kbps baud rate) (Modbus RTU/ASCII) <ul style="list-style-type: none"> (1) Serial Port A (4-wire RS-232/RS-485 Full Duplex/RS-485 Half Duplex; 2-wire RS-485)
	One Ethernet Port (TCP/IP) 100 BaseT <ul style="list-style-type: none"> Modbus TCP
Device compatibility	FloBoss 103, FloBoss S600 flow computer, ROC 107
Digital, analog, and frequency inputs	
Digital Input(s) (Selectable)	(1) Single polarity (for flow calibration gating - contact closure) <ul style="list-style-type: none"> Single input for starting and stopping Four pulse configurations available
Analog Input(s)	(2) 4-20 mA <ul style="list-style-type: none"> AI-1 Temperature AI-2 Pressure <p>Note: The analog-to-digital conversion accuracy is within $\pm 0.05\%$ of full scale over the operating temperature range.</p> <p>Note: AI-1 and AI-2 are electronically isolated. The input contains a series resistance so HART® Communicators can be connected to configure sensors. A 24 Volt DC power supply is available to provide power to the sensors.</p>

Table 1-3 Liquid Ultrasonic Flow Meter specifications

Digital, analog, and frequency outputs	
Frequency/Digital Output(s)	<p>The meter has user-configurable selections for either a frequency output or Digital status (FODO) (Also see Section 3.6.1)</p> <p>(3) Frequency/Digital Outputs</p> <ul style="list-style-type: none"> • FODO1 (four possible output configurations) • FODO2(eight possible output configurations) • FODO3(eight possible output configurations) <p>Frequency or Digital Output parameter pairs (see Section 3.6.1)</p> <p>Frequency or Digital Outputs (FODO 1) source selections:</p> <ul style="list-style-type: none"> • (FO1A, DO1A, FO1B, DO1B) <p>Frequency or Digital Outputs (FODO 2) source selections</p> <ul style="list-style-type: none"> • (FO1A, DO1A, FO1B, DO1B, FO2A, DO2A, FO2B, DO2B) <p>Frequency or Digital Outputs (FODO 3) source selections</p> <ul style="list-style-type: none"> • (FO1A, DO1A, FO1B, DO1B, FO2A, DO2A, FO2B, DO2B) <p>Mode options:</p> <ul style="list-style-type: none"> • Open Collector (requires external excitation supply voltage and pull-up resistor) • TTL (internally powered by the meter 0-5 VDC signal) <p>Channel B Phase options:</p> <ul style="list-style-type: none"> • Lag forward, Lead reverse (Phase B lags Phase A while reporting forward flow, leads Phase A while reporting reverse flow) • Lead forward, Lag reverse (Phase B leads Phase A while reporting forward flow, lags Phase A while reporting reverse flow) <p>Phase A and Phase B output (based on flow direction)</p> <ul style="list-style-type: none"> • Reverse flow - output only reports flow in the reverse direction. For frequency outputs, Phase B of the output is 90 degrees out of phase with Phase A. • Forward flow - output only reports flow in the forward direction. For frequency outputs, Phase B of the output is 90 degrees out of phase with Phase A. • Absolute - output reports flow in both directions. For frequency outputs, Phase B of the output is 90 degrees out of phase with Phase A. • Bidirectional - output reports flow on Phase A only in the forward direction and on Phase B only in the reverse direction. <p>Maximum frequency for the frequency outputs</p> <ul style="list-style-type: none"> • 1000Hz • 5000Hz
Analog Output(s)	<ul style="list-style-type: none"> • (1) 4-20 mA independently configurable analog output (HART) • (1) 4-20 mA independently configurable analog output (conventional) <p>The analog output zero scale offset error is within $\pm 0.1\%$ of full scale and gain error is within $\pm 0.2\%$ of full scale. The total output drift is within ± 50 ppm of full scale per $^{\circ}\text{C}$.</p>

1.7 Pre-installation considerations

- Review equipment handling and lifting, environmental, electrical, operational and personnel safety procedures and regulations
- Pipeline equipment code compliance, ASME as standard offering. Other code compliance if requested.
- Proper Inlet/outlet meter tube piping for reasonable stable flow to the settling chamber (first meter tube spool upstream of the meter).
- Electrical safety compliance; UL, CSA, ATEX, IECEx etc.
- Civil and structural good practices compliance
- Contractual agreements or governmental compliance (or both)
- In-situ performance test procedures
- Field tested advanced meter health and flow dynamics diagnostics
- Data collection and retention procedures

1.8 Safety

The Rosemount 3810 Series Liquid Ultrasonic Flow Meters are suitable for use in U.L. Class 1, Division 1, Group C and D hazardous locations.

⚠ WARNING

SAFETY HAZARDS

Observe all precautionary labels posted on the equipment and safety messages throughout the meter documentation.

Failure to do so may result in injury to personnel or cause damage to the equipment.

The Rosemount 3810 Series Liquid Ultrasonic Meter is approved to the ATEX Directive 94/9/EC. See [Appendix A](#), Drawing DMC-DMC-004936.

Figure 1-8 Rosemount 3810 Series Liquid Ultrasonic Meter ATEX approval

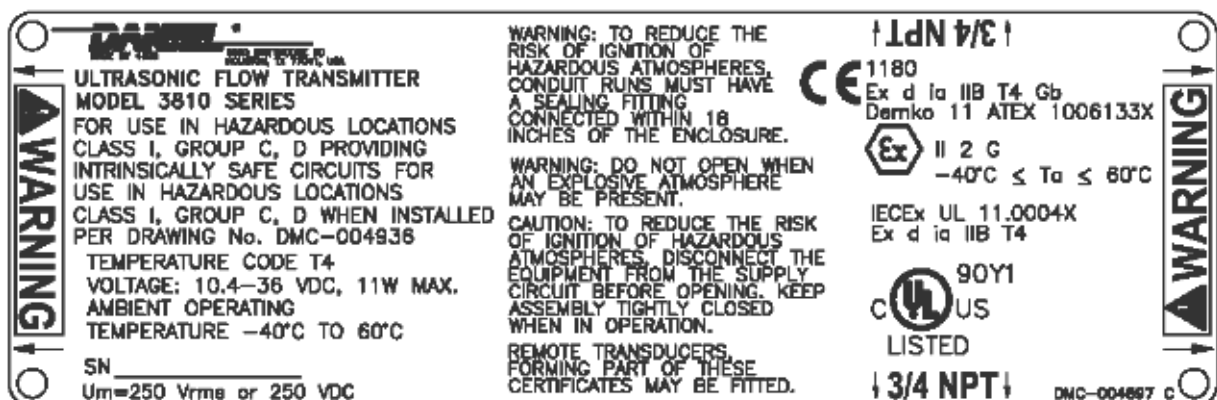

1.9 Certifications and Approvals

Rosemount 3810 Series Liquid Ultrasonic Flow Meters have electrical, metrology, intrinsic safety and Pressure Equipment Directive certifications, approvals and lab testing and calibration certifications by the agencies listed below. Refer to the nameplate tag on the meter body, the wiring diagram (Drawing DMC - 0004936) in [Appendix A](#) and observe all safety precautions. Rosemount 3810 Series Liquid Ultrasonic Flow Meters operate within the pressure and temperature range of the device (also see [Section 1.6](#) for meter specifications).

The Rosemount 3810 Series Liquid Ultrasonic Flow Meters certifications and approvals are available from Emerson.

- ATEX (British Approval Service for Electrical Equipment in Flammable Atmospheres)
- IECEx (International Electrotechnical Commission for explosive atmospheres)
- U.L. (Underwriter Laboratories)
- U.L.C. (Underwriter Laboratories of Canada)
- PED (BSI Group) British Standards Institution
- INMETRO (National Institute of Metrology, Quality and Technology)
- Demko (Dansk Elektrisk Materiel Kontrol - Danish Electrical Equipment Supervision)
- GOST R (Government Standard Russia)
- L.A.B. (Laboratory Accreditation Bureau) ISO/IEC 17025:2005

1.10 FCC compliance

This equipment has been tested and found to comply with the limits for a Class A digital device, pursuant to Part 15 of the FCC Rules. These limits are designed to provide reasonable protection against harmful interference when the equipment is operated in a commercial environment.

This equipment generates, uses, and can radiate radio frequency energy and, if not installed and used in accordance with the instruction manual, may cause harmful interference to radio communications. Operation of this equipment in a residential area is likely to cause harmful interference in which case the user will be required to correct the interference at his own expense.

NOTICE

Changes or modifications not expressly approved by the party responsible for compliance could void the user's authority to operate the equipment.

Section 2: Mechanical installation

2.1 Meter components, piping, lifting and mounting

Refer to the following sections for components, piping recommendations, lifting procedures with hoist rings and slings, mounting in heated or cooled pipelines and safety warnings and precautions.

2.1.1 Important safety information

⚠ CAUTION

SURFACE TEMPERATURE HAZARD

The meter body and piping may be extremely hot or cold.

Wear appropriate personal protective equipment when coming in contact with the meter. Failure to do so may result in injury.

⚠ WARNING

CUTTING HAZARD

Sharp edges may be present on the meter.

Wear appropriate personal protective equipment when working on the meter. Failure to do so may cause serious injury

⚠ CAUTION

TRANSPORTATION HAZARD

When moving the meter, do not insert the forks of a forklift into the bore.

Inserting the forks may cause the meter to become unstable, resulting in injury or damage to the bore and sealing face.

⚠ CAUTION

TRIPPING HAZARD

Clear all obstacles or obstructions from the work area when transporting, installing or removing the meter.

Failure to clear the work area may cause injury to personnel.

⚠ WARNING

CRUSHING HAZARD

Do not remove flange stabilizers. Screwed feet may be removed after the meter is installed into piping (see Figure 1-3, Figure 1-4 and Figure 1-5). Cradles may be removed after the meter is installed in piping (see Figure 1-6).

Meter bodies with stabilizers, screwed feet or cradles removed may allow the meter to tip over or roll, resulting in serious injury or equipment damage.

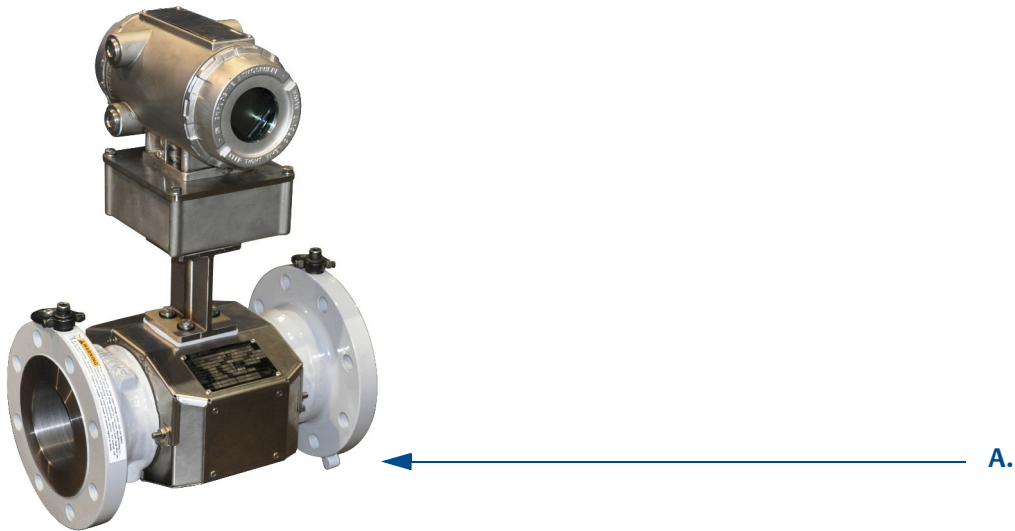

A. Flange stabilizers

⚠ CAUTION

ESCAPING FLUIDS HAZARD

The purchaser of the meter is responsible for the selection of Rosemount components/seals and materials compatible with the chemical properties of the measurement fluid.

Failure to select suitable meter components/seals may cause escaping fluids, resulting in injury or equipment damage.

Consult your Emerson Flow Service representative to ensure you purchase the correct components and seals for your application.

⚠ WARNING

FLUID CONTENTS MAY BE UNDER PRESSURE

When the meter is under pressure, DO NOT attempt to remove or adjust the transducer housing.

Attempting to do so may release pressurized fluid, resulting in serious injury or equipment damage.

⚠ WARNING

FLUID CONTENTS MAY BE HAZARDOUS

The meter must be fully depressurized and drained before attempting to remove the transducer housing. If fluid begins to leak from the transducer housing, immediately reinstall it.

Failure to do so may cause serious injury or equipment damage.

A. _____

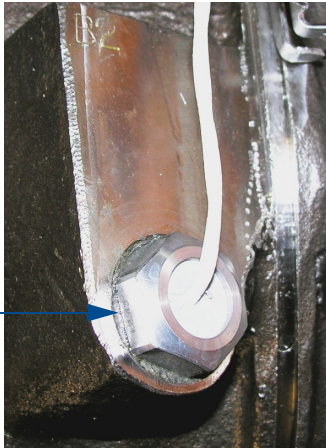

A. Transducer housing

2.2 Piping recommendations

⚠ WARNING

BURST HAZARD

Before pipeline cleaning and maintenance (“pigging operations”), remove straightening vanes or flow conditioners.

Failure to do so may cause excessive pressure in the meter system, resulting in serious injury/ death or equipment damage.

Figure 2-1 Ultrasonic Flow Meter with flow conditioner for unidirectional flow

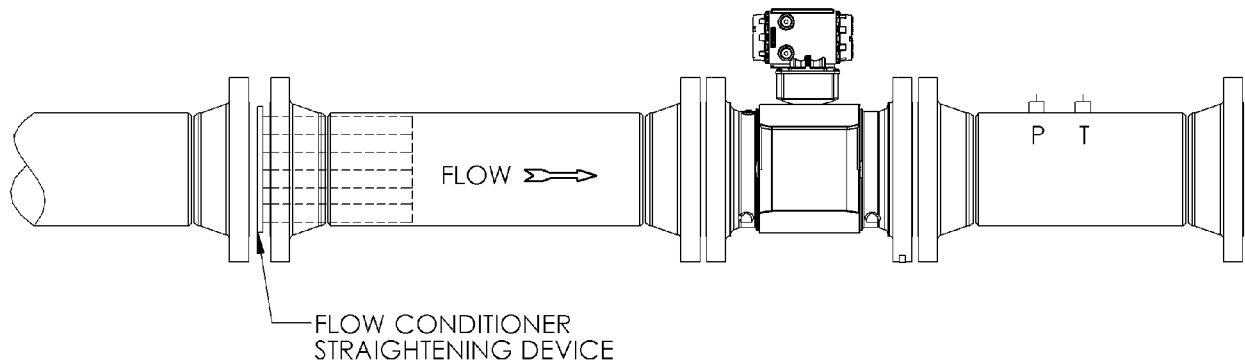
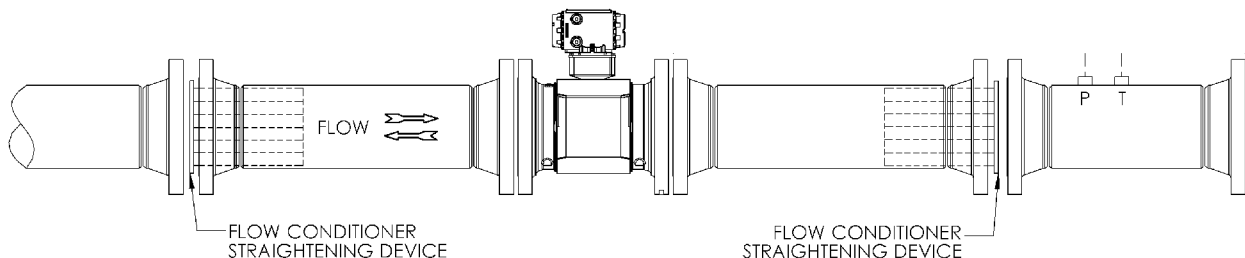

Figure 2-2 Ultrasonic Flow Meter with flow conditioner for bidirectional flow



Sunshields, provided by the customer, may be required to prevent exceeding the process fluid temperature when the meter is mounted in a location with extremely hot climates.

CAUTION

SUNSHIELD PROTECTION

Install a sunshield to prevent prolonged exposure to direct sunlight in extreme climates.

Failure to shield the meter may result in exceeding the process temperature range and damage transmitter electronics.

NOTICE

For optimal flow measurement conditions, Emerson suggests the piping configurations below. Regardless of the configuration selected, the user agrees to accept full responsibility for the site piping design and installation.

Flow conditioning is recommended for best measurement results.

- Honed or un-honed meter tube(s)
- Flow direction (unidirectional or bidirectional)
- Correct meter size selection - too low may cause poor flow stability (thermal convection or too fast may cause erosion problems and resonance, cracks or failure of probes or thermowells (approximately .6 to 12 m/sec or 2 to 40 ft/sec).
- Space availability for meter lengths (to allow inlet piping customization)
- Concentric alignment pins or flange concentricity technique considerations

Figure 2-3 Piping recommendations unidirectional flow

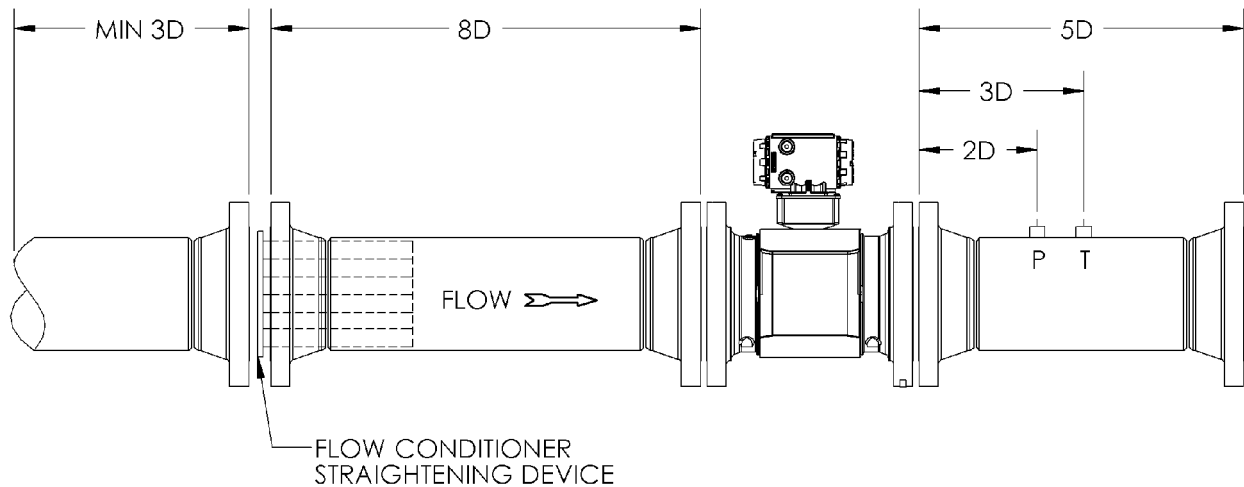
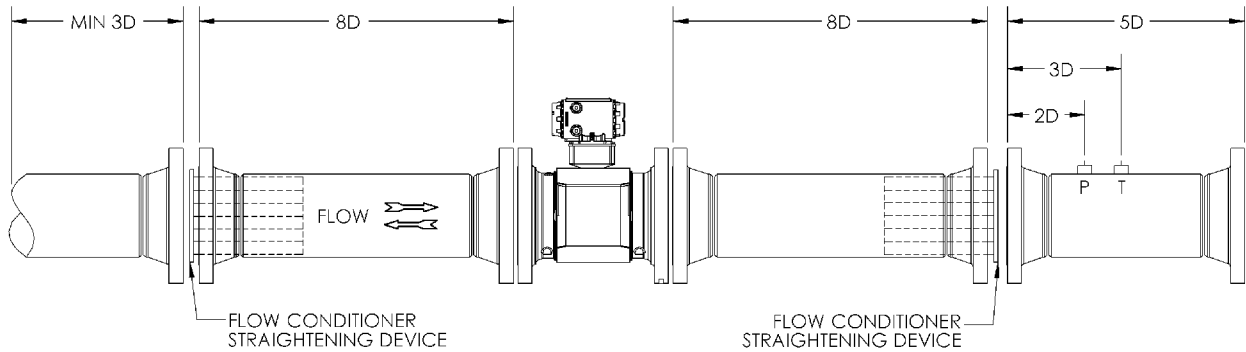

Figure 2-4 Piping recommendations bidirectional flow



All pipe lengths are minimum:

- D = Nominal pipe size in inches (i.e. 6" pipe size; 10 D = 60 in)
- P = Pressure measurement location
- T = Temperature measurement location

Refer to the ultrasonic meter product data sheet for piping information. The Liquid Ultrasonic Flow Meter Datasheets may be downloaded from the Emerson website:

<http://www2.emersonprocess.com/en-US/brands/emerson/Flow/ultrasonics/Pages/Ultrasonic.aspx>

NOTICE

To access the product datasheet, from the Rosemount products page (above link), select the Rosemount™ Liquid Ultrasonic Flow Meter link, click the Documentation tab, expand the Data Sheets - Bulletins - Catalogs tab, then select the Data Sheet.

Meter tube dimensions with tube bundle or profiler plate for uni-directional and bi-directional flow, the minimum straight pipe length is as follows:

Table 2-1 Piping recommendation for uni-directional or bi-directional flow

UniDirectional Flow	BiDirectional Flow
8D up stream (with a flow conditioner)	8D up stream (with a flow conditioner)
8D up stream (no flow conditioner)	8D up stream (no flow conditioner)
5D in front of flow conditioners if used	5D in front of flow conditioners if used

- The bore of the mating piping should be within 1% of the meter inside diameter.
- The meter is provided with dowel pins to align the meter body bore with the bore of the mating piping.
- The Rosemount™ Liquid Ultrasonic Flow Meter should be mounted in horizontal piping with the chord paths horizontal

CAUTION

FAULTY METER INSTALLATION

Correctly install the meter.

If meter bodies are mounted or oriented differently than specified above, debris may collect in the transducer ports which could adversely affect the transducer signals, or cause equipment damage.

- Normally, the meter body is installed so that the electronics assembly is on the top of the meter. If there is insufficient space above the piping for this arrangement, the meter can be ordered with extra long transducer cables for remote mounting or the meter housing can be installed with the electronics assembly on the bottom.
- Mounting the meter with the electronics assembly on the bottom will require the meter to be lifted with slings only (see Section 2.4.4). The meter bodies do not provide mounting holes for hoist rings when the meter is rotated with the electronics assembly in the bottom position.
- The mating piping should include temperature and pressure measurement connections located a minimum of two nominal pipe diameters length down stream of the meter, or per API MPMS 5.8.

2.3 Safety engineered swivel hoist rings and lifting slings

A Rosemount™ Ultrasonic meter can be safely lifted and maneuvered into and out of a meter run for installation or service by obeying the following instructions.

⚠ WARNING

LIFTING HAZARD

Lifting a Rosemount™ Ultrasonic meter with other equipment

The following lifting instructions are for installation and removal of the Rosemount™ Ultrasonic meter **ONLY**. The instructions below do not address lifting the Rosemount™ Ultrasonic meter while it is attached, bolted, or welded to meter tubes, piping, or other fittings.

Using these instructions to maneuver the Rosemount™ Ultrasonic meter while it is still attached, bolted, or welded to a meter tube, piping, or other fitting may result in equipment damage, serious injury, or death.

The operator must refer to their company's hoisting and rigging standards, or the DOE-STD-1090-2004 Hoisting and Rigging standard if such company standards do not exist, for lifting and maneuvering any assembled meter tube and associated piping.

⚠ WARNING

CRUSHING HAZARD

During meter installation or removal, always place the unit on a stable platform or surface that supports its assembled weight.

Failure to do so could allow the meter to roll, resulting in serious injury or equipment damage.

NOTICE

Prior to lifting the unit, refer to the nameplate or outline dimensional (general arrangement) drawing for the assembled weight.

When lifting a Rosemount™ Ultrasonic meter by itself, Emerson recommends two methods. These methods are:

- Using appropriately rated Safety Engineered Swivel Hoist Rings installed in the Rosemount™ Ultrasonic meter end flanges.
- Using appropriately rated lifting slings positioned at designated areas of the Rosemount™ Ultrasonic meter.

Both methods must be used in conjunction with all appropriate company hoisting and rigging standards or the [DOE-STD-1090-2004 HOISTING AND RIGGING](#) standard if such company standards do not exist. Refer to the following sections for more information on these two methods.

2.4 Use of appropriate safety engineered swivel hoist rings in meter end flanges

Rosemount™ Ultrasonic meters come equipped with a tapped hole located on the top of each meter body end flange. A flat machined surface surrounds each tapped hole (see Figure 2-5). This feature provides complete surface contact **ONLY** between the meter flange and an OSHA compliant Safety Engineered Swivel Hoist Ring as shown in Figure 2-6.

Operators **SHALL NOT** use Eye Bolts (see Figure 2-6) in the Rosemount™ Ultrasonic meter flange tapped holes to aid in lifting or maneuvering the unit.

Operators **SHALL NOT** use other Hoist Rings that do not fully seat flush with the counter bore on the top of the meter flanges.

Figure 2-5 Meter end flange with tapped flat-counterbore hole for hoist ring

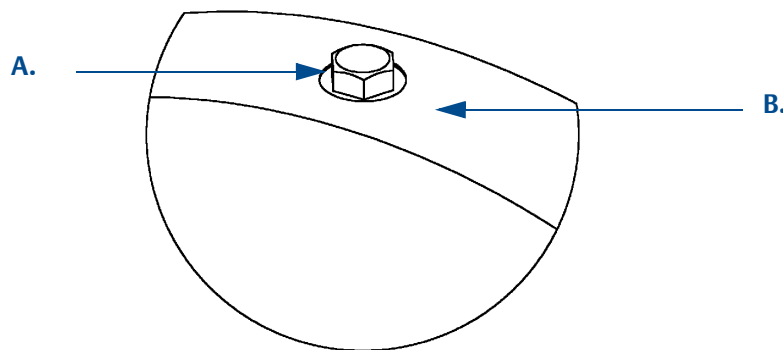

- A. Plug bolt
- B. Flat counterbore surface

Figure 2-6 Safety engineered hoist ring and non-compliant eye bolt

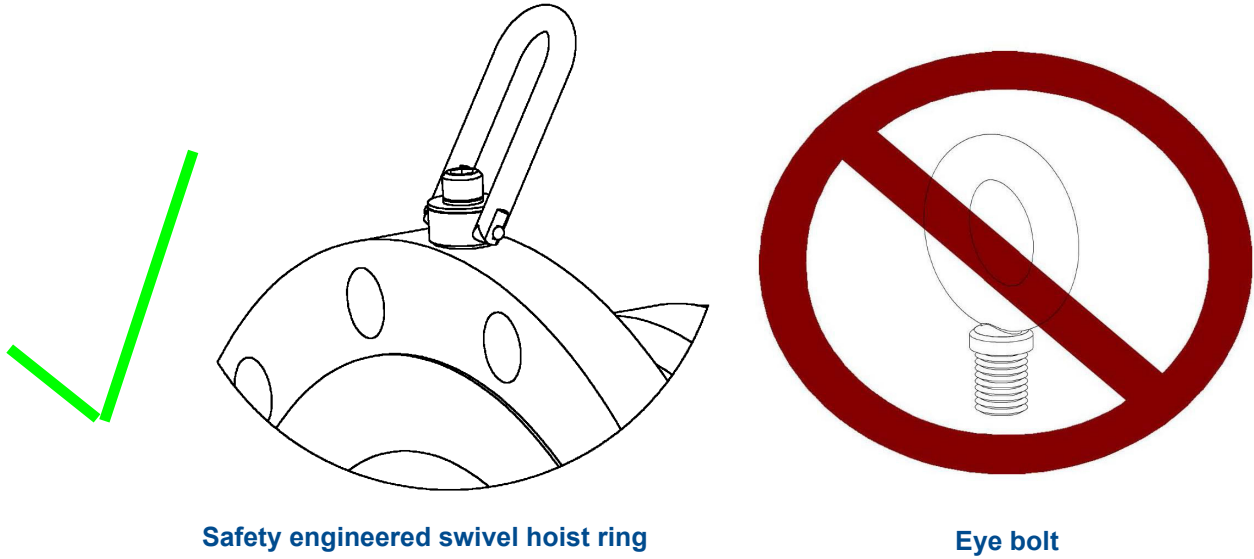

2.4.1 Safety precautions using safety engineered swivel hoist rings

Read and follow the Safety Precautions listed below:

1. Meters must only be lifted by personnel properly trained in the safe practices of rigging and lifting.
2. Remove the plug bolts installed in the tapped holes on the top of the flanges. Do not discard the bolts as they must be reinstalled once the lifting operation is complete to prevent corrosion of the tapped holes.
3. Make sure the tapped holes on the meter are clean and free of debris before installing the hoist rings.
4. Use only the safety engineered swivel hoist rings that are rated for lifting the meter. Do not use any other type of hoist rings with the same screw size or heavy duty hoist rings. The meter tapping and counter bore size are suitable only for the hoist rings specified by Emerson.
5. When installing a hoist ring, make sure the base surface of the hoist ring fully contacts the machined flat surface of the tapped hole. If the two surfaces do not come in contact then the hoist ring will not hold its full rated load. Torque the hoist ring attachment bolts to the limit indicated on the hoist rings.
6. After installation of the hoist rings, always check that the ring rotates and pivots freely in all directions.
7. **NEVER** attempt to lift the meter using only one hoist ring.

8. **Always** use separate slings for each hoist ring. **NEVER** reeve one sling through both hoist rings. The slings must be of equal length. Each sling must have a load rating that equals or exceeds the hoist ring load rating. The angle between the two slings going to the hoist rings must never exceed 90 degrees or the load rating of the hoist rings will be exceeded.

Figure 2-7 90 Degree angle between slings

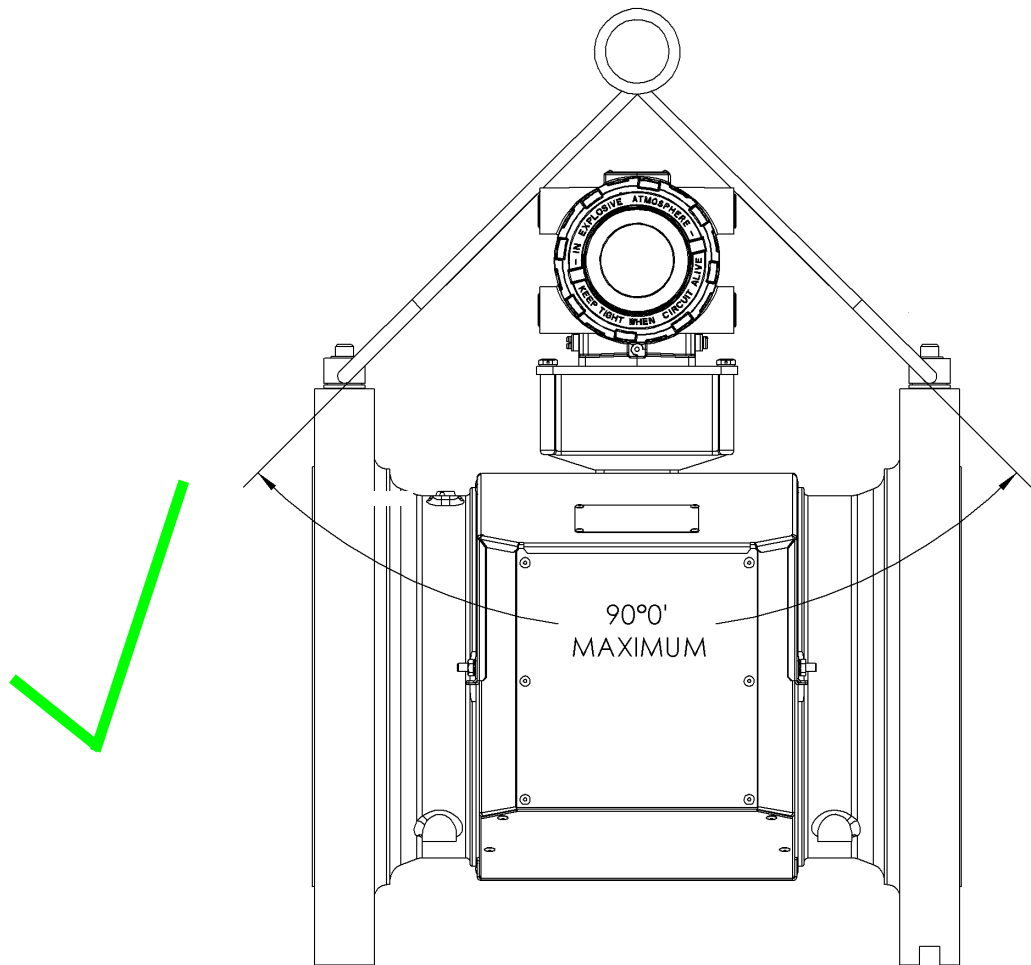

9. **Extended temperature mounting bracket option: NEVER** allow the slings to contact the electronics enclosure. Damage to the enclosure may occur. Use a spreader bar with the slings to prevent contact with the electronics enclosure and the base enclosure (see Figure 2-7).

If the meter has a body design with the Techlok ends and the cradle, lift using a properly rated quadruple leg chain or strap sling and the four hoist rings on the cradles.

Figure 2-8 3818 meter with Techlok ends and cradle

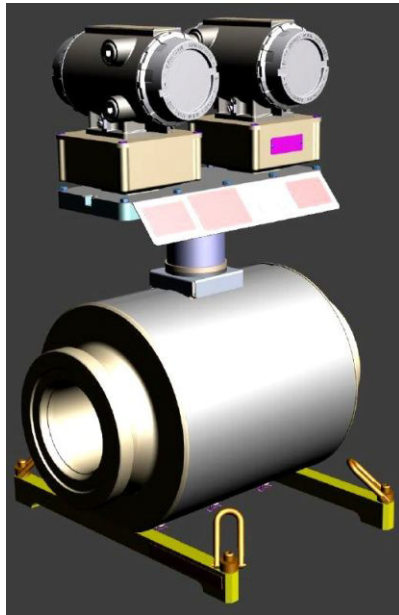

If the slings do come in contact with the electronic enclosure then remove the four bolts holding the enclosure to its base and temporarily remove the head from the meter during the lifting operation. You will need to unplug the cable on the Acquisition Module. Two screws hold this cable in place. Once the lifting operation is complete, reattach and secure the electronics cable on the Acquisition Module, return the electronics enclosure to its original position, replace the bolts, and secure the enclosure in place.

Figure 2-9 Sling contacting electronics enclosure

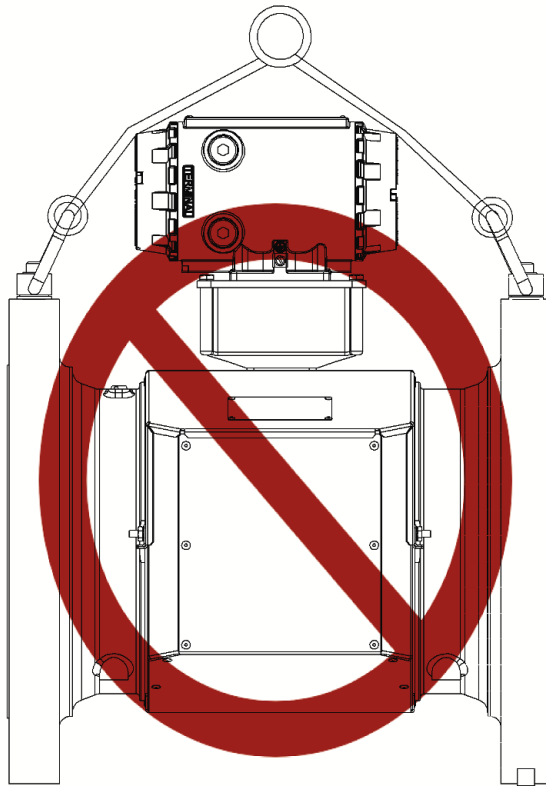

10. Lifting the meter with the upper enclosure installed but without the bolts installed, may cause the electronics to fall and cause personal injury or equipment damage.
11. **NEVER** apply shock loads to the meter. Always lift the meter gradually. If shock loading ever occurs, the hoist ring must be inspected per manufacturer's ASME recommendations prior to be placed in any further service. If a proper inspection cannot be performed, discard the hoist ring.
12. **NEVER** lift with any device, such as hooks, chains, or cables that could create side pulls that could damage the hoist ring.
13. **NEVER** lift more than the ultrasonic meter assembly including electronics and transducers with the hoist rings. The only exception, for carbon steel hoist rings only, is that it is safe to lift the meter with one ASME B16.5 or ASME B16.47 blind flange bolted to each end flange of the meter. **NEVER** use the hoist rings on the meter to lift other components such as meter tubes, piping or fittings attached to the meter. Doing so will exceed the load rating of the hoist rings.
14. Remove the hoist rings from the meter after lifting is completed and store them in an appropriate case or container per their manufacturer's ASME recommendation.
15. Apply heavy lubricant or anti-seize to the threads of the plug bolts and reinstall the plug bolts to keep the tapped holes free of debris and to prevent corrosion. If the meter has the Techlok ends and cradle, install the plug bolts into the cradle.

2.4.2 How to obtain safety engineered swivel hoist rings

A list of approved manufacturers of safety engineered hoist rings is shown below:

- American Drill Bushing Company(www.americandrillbushing.com)
- Carr Lane Manufacturing Company (www.carrlane.com)

Select an approved supplier from the list below. These vendors can supply the safety-engineered hoist rings. This is not intended to be a complete list.

- Fastenal (www.fastenal.com)
- Reid Tools (www.reidtool.com)

The appropriate hoist rings can also be purchased directly from Emerson. [Table 2-2](#) provides part numbers for reference:

Table 2-2 Hoist ring part number lookup table

Rosemount part number ¹	Hoist ring thread size & load rating ¹	American Drill Bushing Co. P/N ¹	Carr Lane Manufacturing Co. P/N ¹
Carbon steel			
1-504-90-091	3/8"-16UNC, 1000 lb.	23053	CL-1000-SHR-1
1-504-90-092	1/2"-13UNC, 2500 lb	23301	CL-23301-SHR-1
1-504-90-093	3/4"-10UNC, 5000 lb.	23007	CL-5000-SHR-1
1-504-90-094	1"-8UNC, 10000 lb.	23105	CL-10000-SHR-1
1-504-90-095	1-1/2"-6UNC, 24000 lb.	23202	CL-24000-SHR-1
Stainless steel			
1-504-90-141	3/8"-16UNC, 500 lb.	29053	CL-29053-SHR-S
1-504-90-142	1/2"-13UNC, 1250 lb	29301	CL-29301-SHR-S
1-504-90-143	3/4"-10UNC, 2500 lb.	29007	CL-2500-SHR-1-S ²
1-504-90-144	1"-8UNC, 5000 lb.	29105	CL-29105-SHR-S
1-504-90-145	1-1/2"-6UNC, 12000 lb.	29202	CL-29202-SHR-S

1. Note: The part numbers include only one hoist ring. Two hoist rings are required per meter.

2. Note: This is a new Carr Lane part number. Was CL-29007-SHR-1.

CAUTION

HOIST RING LIFTING HAZARD

Stainless steel safety engineered hoist rings are designed for lifting specific meter weights without the blind flanges attached. Do not attempt to lift the meter with blind flanges attached or exceed the lifting rating of the hoist ring as shown in [Table 2-2](#).

Failure to do so may cause the hoist ring to break which may cause serious injury to personnel or damage the equipment.

2.4.3 What size safety engineered swivel hoist ring do you need?

To determine the size of the hoist rings required for your meter, use the appropriate table below for Liquid Ultrasonic Meters (see Table 2-3). Look down the column that matches the ASME rating of your meter. Find the row that contains your meter size. Follow the row to the end to find the appropriate hoist ring part number.

Table 2-3 Hoist ring lookup table for Rosemount Model Liquid Ultrasonic Flow Meters

Carbon steel hoist ring	ASME rating	Rosemount part number
Meter size	ASME 150	
3"		1-504-90-091
4"		1-504-90-091
14"		1-504-90-091
	ASME 300	
16"		1-504-90-092
Stainless steel hoist ring	ASME rating	Rosemount part number
Meter size	ASME 150	
24"		1-504-90-143
	ASME 300	
6"		1-504-90-141
8"		1-504-90-141
10"		1-504-90-141
12"		1-504-90-142
14"		1-504-90-142
16"		1-504-90-142
20"		1-504-90-143
	ASME 1500	
2"		1-504-90-141
	ASME 2500	
6"		1-504-90-141
8"		1-504-90-141
10"		1-504-90-142
12"		1-504-90-142
14"		1-504-90-142
20"		1-504-90-143

2.4.4 Appropriately rated lifting slings

The following instructions are intended to provide general guidelines for proper lifting slings of the meter by itself. **CAUTION: DO NOT** lift the meter with stainless steel hoist rings with blind flanges installed on the meter.

These instructions are intended to be followed in addition to your company's standards or the DOE-STD-1090-2004 Hoisting and Rigging standard if such company standards do not exist.

Safety precautions using appropriate rated lifting slings

1. Meters must only be lifted by personnel properly trained in the safe practices of rigging and lifting.
2. **NEVER** attempt to lift the meter by wrapping slings around the electronics enclosure.
3. **NEVER** attempt to lift the meter using only one sling around the meter. Always use two slings wrapped around each end of the body as shown below. A choker style sling is recommended using a spreader bar.

Figure 2-10 Correct sling attachment

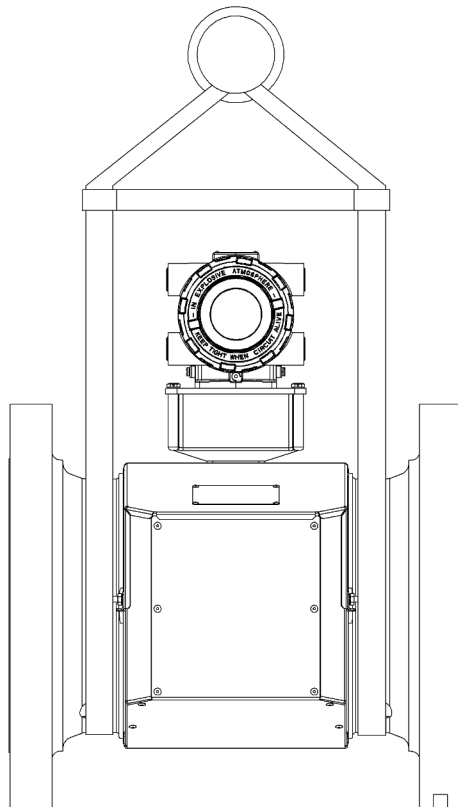

4. Visually inspect the slings prior to use for any signs of abrasion or other damage. Refer to the sling manufacturer's procedures for proper inspection of the particular sling you are using.

5. Only use slings with ratings that exceed the weight to be lifted. Reference your company's standards for safety factors that must be included when calculating the load rating.
6. **NEVER** allow the slings to contact the electronics enclosure or the transducer shrouds. Damage to the meter may occur. If the slings do come in contact with the electronics or the shroud, temporarily remove the head from the meter during the lifting operation (remove the four bolts holding the enclosure to its base and unplug the cable from the Acquisition Module. Two screws hold this cable in place.) Use a spreader-bar on the sling to prevent contact with the electronics or the transducer shroud.
7. Once the lifting operation is complete, reattach and secure the electronics cable to J3 on the Acquisition Module, return the electronics enclosure to its original position, replace the bolts, and secure the enclosure in place. **Caution:** Lifting the meter with the upper enclosure installed but with out the bolts installed, may cause the electronics to fall and cause personal injury or electronics damage.

Figure 2-11 Incorrect sling attachment

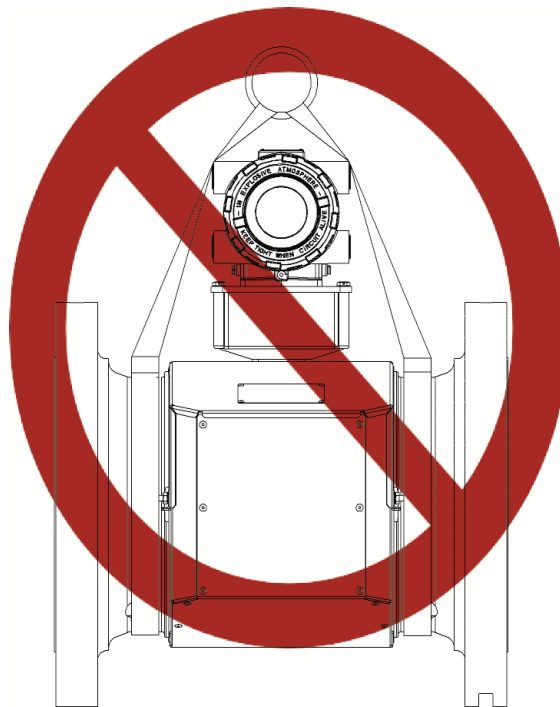

8. **NEVER** apply shock loads to the meter. Always lift the meter gradually. If shock loading ever occurs, the slings must be inspected per manufacturer's procedures prior to being placed in any further service.

2.5 Mounting requirements in heated or cooled pipelines

The ambient operating temperature of the 3810 Liquid Ultrasonic Flow Meter electronics (i.e. Flameproof enclosure and Intrinsically safe base enclosure) is $-40\text{ }^{\circ}\text{C}$ to $+60\text{ }^{\circ}\text{C}$ ($-40\text{ }^{\circ}\text{F}$ to $+140\text{ }^{\circ}\text{F}$).

If the meter is installed into a pipeline which is heated or cooled outside this temperature range it is necessary to remove the Transmitter Electronics enclosure from the meter body (i.e. Spool piece acting as process fluid conduit) and mount it next to the meter body on a pipe stand or with the extended temperature mounting bracket. The process temperature must also not exceed the operating temperature range of the transducers. A meter equipped with the extended temperature mounting bracket electronics may have lower maximum temperature ranges from the ones listed in [Table 2-4](#) below, depending on the maximum ambient operating temperature. Consult the factory to confirm maximum process temperatures when utilizing the extended temperature mounting bracket.

⚠ CAUTION

SURFACE TEMPERATURE HAZARD

The meter body and piping may be extremely hot or cold.

Wear appropriate personal protective equipment when coming in contact with the meter.

Failure to do so may result in injury.

Table 2-4 Transducer operating temperature ranges

<p>Transducers Operating temperature range</p>	<ul style="list-style-type: none"> • LT-10 Operating temperature range: <ul style="list-style-type: none"> – LT-10 (-50 °C to 135 °C) (-58 °F to 275 °F) w/ NBR O-rings, 316 Housings – LT-10 (-40 °C to 150 °C) (-40 °F to 302 °F) w/ FKM O-rings, 316 Housings – LT-10 (-50 °C to 135 °C) (-58 °F to 275 °F) w/ NBR O-rings, Inconel Housings – LT-10 (-40 °C to 150 °C) (-40 °F to 302 °F) w/ FKM O-rings, Inconel Housings) • LT-11 Operating temperature range: <ul style="list-style-type: none"> – LT-11 (-50 °C to 135 °C) (-58 °F to 275 °F) w/ NBR O-rings, 316 Housings – LT-11 (-40 °C to 150 °C) (-40 °F to 302 °F) w/ FKM O-rings, 316 Housings – LT-11 (-50 °C to 135 °C) (-58 °F to 275 °F) w/ NBR O-rings, Inconel Housings – LT-11 (-40 °C to 150 °C) (-40 °F to 302 °F) w/ FKM O-rings, Inconel Housings • LT-14 Operating temperature <ul style="list-style-type: none"> – LT-14 (-50 °C to 135 °C) (-58 °F to 275 °F) w/NBR O-rings, 316 Housings – LT-14 (-40 °C to 175 °C) (-40 °F to 347 °F) w/FKM O-rings, 316 Housings – LT-14 (-50 °C to 135 °C) (-58 °F to 275 °F) w/NBR O-rings, Inconel Housings – LT-14 (-40 °C to 175 °C) (-40 °F to 347 °F) w/FKM O-rings, Inconel Housings • LT-15 Operating temperature <ul style="list-style-type: none"> – LT-15 (-50 °C to 135 °C) (-58 °F to 275 °F) w/NBR O-rings,316 Housings – LT-15 (-40 °C to 175 °C) (-40 °F to 347 °F) w/FKM O-rings, 316 Housings – LT-15 (-50 °C to 135 °C) (-58 °F to 275 °F) w/ NBR O-rings, Inconel Housings – LT-15 (-40 °C to 175 °C) (-40 °F to 347 °F) w/ FKM O-rings, Inconel Housings • LT-16 Operating temperature range <ul style="list-style-type: none"> – LT-16 (-50 °C to 135 °C) (-58 °F to 275 °F) w/ NBR O-rings, 316 Housings – LT-16 (-40 °C to 175 °C) (-40 °F to 347 °F) w/ FKM O-rings, 316 Housings – LT-16 (-50 °C to 135 °C) (-58 °F to 275 °F) w/ NBR O-rings, Inconel Housings – LT-16 (-40 °C to 175 °C) (-40 °F to 347 °F) w/ FKM O-rings, Inconel Housings) • LT-17 Operating temperature range <ul style="list-style-type: none"> – LT-17 (-50 °C to 135 °C) (-58 °F to 275 °F) w/ NBR O-rings, 316 Housings – LT-17 (-40 °C to 175 °C) (-40 °F to 347 °F) w/ FKM O-rings, 316 Housings – LT-17 (-50 °C to 135 °C) (-58 °F to 275 °F) w/ NBR O-rings, Inconel Housings – LT-17 (-40 °C to 175 °C) (-40 °F to 347 °F) w/ FKM O-rings, Inconel Housing
--	--

Section 3: Electrical installation

3.1 Cable length TTL mode

The maximum cable length is 2000 feet when the “TTL” mode is selected.

3.2 Cable length Open Collector mode

For the “open collector” mode, the maximum cable length depends on the cable parameters, pull-up resistance used, the maximum frequency to output, and frequency input parameters being driven. The following table provides estimated cable lengths for different pull-up resistor values and different Max Frequency settings in the meter using the following cable parameters. The table also provides an estimated cable voltage drop which indicates how much voltage will be across the cabling and effectively indicates to what voltage level the frequency input can be pulled down to by the frequency output.

If the voltage drop is higher than the voltage required for the frequency input to see a low state, then the configuration will most likely not work for your system. Performance of frequency outputs will vary from this table with setup and frequency input being driven.

Table 3-1 Configurations for open collector frequency outputs

Cable	Cable resistance	Cable	Pull-up resistance	Total	Maximum frequency	Sink	Cable voltage drop
Length	(2 Conductors)	Capacitance	Resistance	Resistance	Frequency	Current	(2 Conductors)
(x1000ft)	Ω	nF	Ω	Ω	(Hz)	(A)	VDC
0.5	16.8	10.00	1000	1016.8	5000	0.024	0.397
1	33.6	20.00	1000	1033.6	1000	0.023	0.780
2	67.2	40.00	1000	1067.2	1000	0.022	1.511
4	134.4	80.00	1000	1134.4	1000	0.021	2.843
0.5	16.8	10.00	500	516.8	5000	0.046	0.780
1	33.6	20.00	500	533.6	5000	0.045	1.511
1.7	57.12	34.00	500	557.12	5000	0.043	2.461
6.5	218.4	130.00	500	718.4	1000	0.033	7.296

The 22 AWG wire characteristics are as follows:

- Capacitance = 20 pF/ft or 20 nF/1000 ft (between two wires)
- Resistance = 0.0168 Ohms/ft or 16.8 Ohms/1000 ft
- Pull-up voltage is 24 VDC

3.3 Grounding meter electronics housing

Rosemount 3810 Series Liquid Ultrasonic Flow Meter electronics should be internally grounded for intrinsically safe operations. Connect a wire to the chassis ground lug installed inside the Transmitter Electronics Enclosure as the primary ground. A secondary ground is located outside of the Transmitter Electronics Enclosure (see Figure 3-2). Digital grounds should never be connected to chassis ground.

NOTICE

The internal grounding terminal shall be used as the primary equipment ground. The external terminal is only a supplemental bonding connection where local authorities permit or require such a connection.

Figure 3-1 Transmitter Electronics Enclosure internal chassis ground

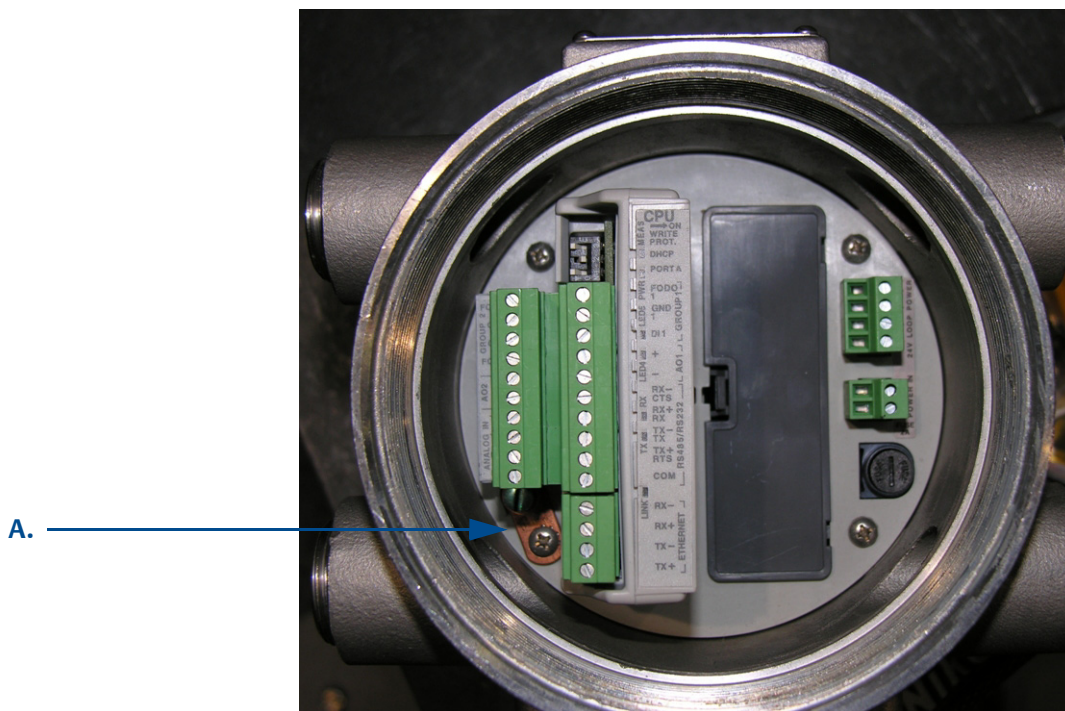

A. Transmitter Electronics Enclosure internal ground lug

Figure 3-2 External ground lug

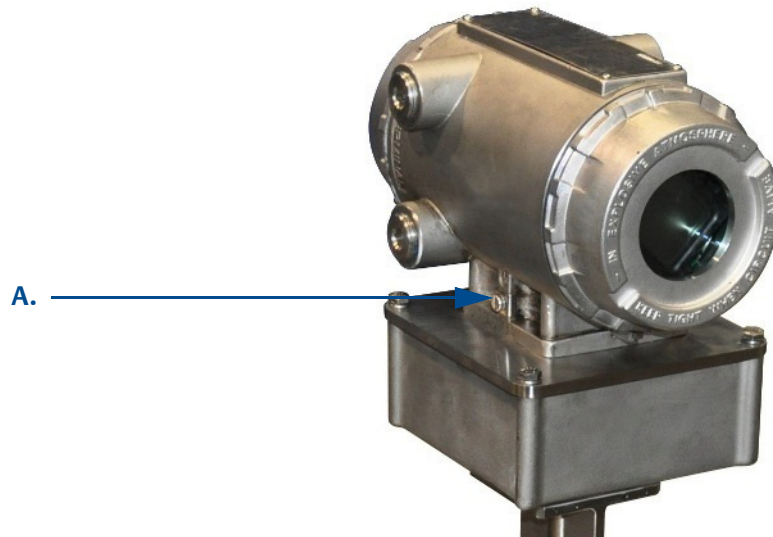

A. External ground lug

3.4 Conduit seals

Rosemount 3810 Series Liquid Ultrasonic Flow Meters require conduit seals for installations in hazardous environments. Adhere to safety instructions to protect personnel and equipment.

⚠ WARNING

HAZARDOUS VOLTAGE INSIDE

Do not open the Transmitter Electronics Enclosure when an explosive gas atmosphere is present. Disconnect equipment from supply circuit before opening.

Failure to remove power may result in serious injury or death.

⚠ WARNING

DEATH OR SERIOUS INJURY MAY OCCUR

Explosion hazard. Substitution of components may impair intrinsic safety.

Do not disconnect equipment unless power has been removed or the area is known to be non-hazardous.

3.4.1 Startup for systems using explosion-proof conduit

1. Assemble flexible conduit (recommended by Emerson) to the Transmitter Electronics Enclosure. A conduit seal fitting is required within 18 inches (457 mm) of the enclosure.
2. Check to make certain that all power to field wiring is turned **OFF**.

⚠ WARNING

HAZARDOUS VOLTAGE INSIDE

Do not open the Transmitter Electronics Enclosure when an explosive gas atmosphere is present. Disconnect equipment from supply circuit before opening the enclosure.

Failure to remove power may result in serious injury or death.

3. Remove the end cap nearest the conduit entry to gain access to the transmitter electronics.
4. Pull the field wiring into the electronics enclosure.

5. Complete the field connection wiring as shown in Figure 3-3 and in Section 3.5.

Figure 3-3 Transmitter electronics enclosure wiring

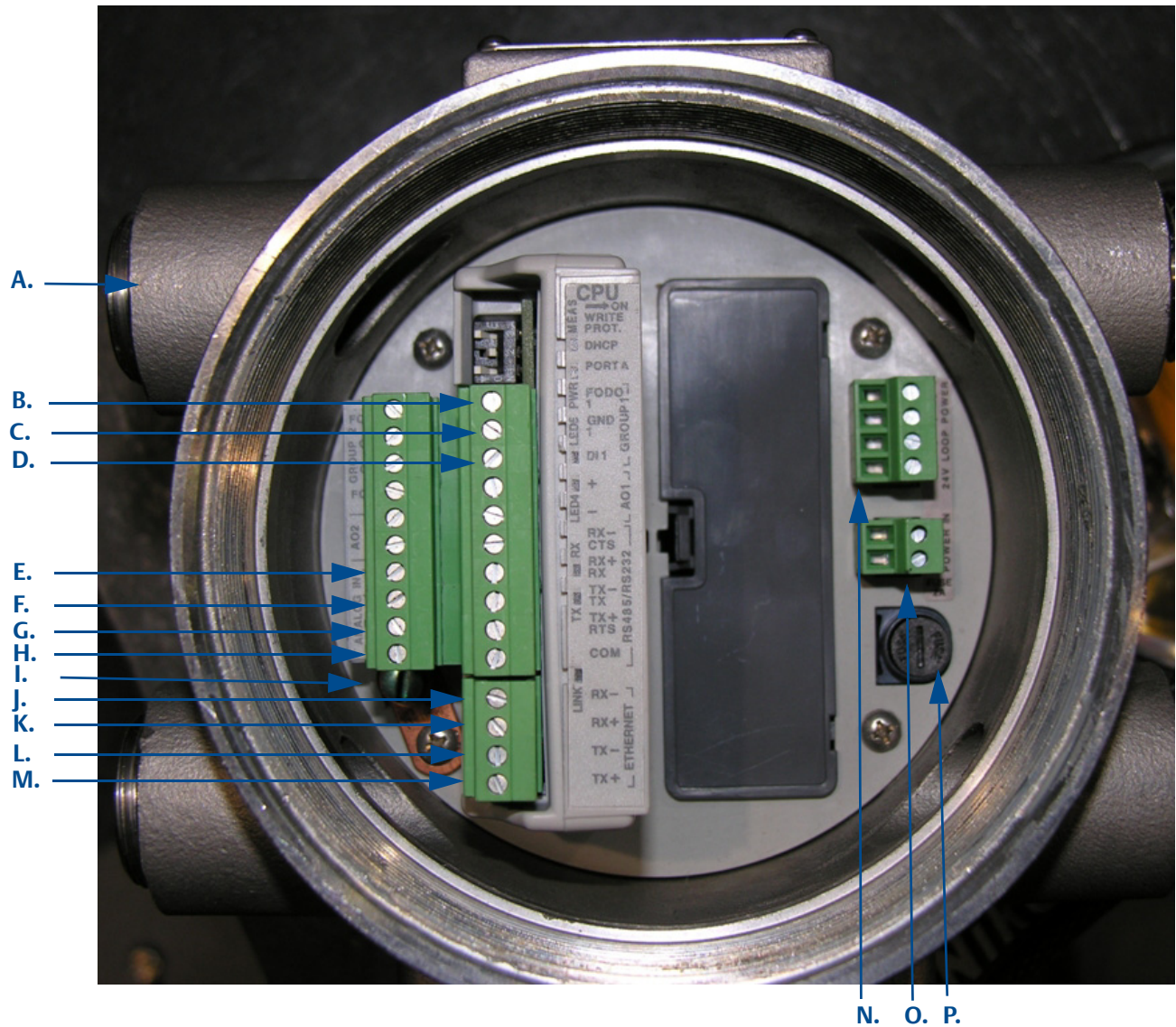

- A. Conduit wiring entry (four entries)
- B. Pulse out
- C. Ground/Prover switch -
- D. Prover switch +
- E. Temperature transmitter +
- F. Temperature transmitter -
- G. Pressure transmitter +
- H. Pressure transmitter -

- I. Internal ground lug
- J. Ethernet (orange and white wire)
- K. Ethernet (orange wire)
- L. Ethernet (green and white wire)
- M. Ethernet (green wire)
- N. 24 VDC loop power
- O. 10.4 - 36 VDC power
- P. Fuse holder

6. Apply electrical power to the system and verify the field connections are working correctly. Allow the system to run for the time specified by the customer and an electrician has fully tested the connections. After the Acceptance Test is witnessed and approved, seal the conduit.
7. Power down the system and apply the sealing compound to the conduit and allow the compound to set in accordance with manufacturer specifications.
8. Install the security latches and wire seals on the Transmitter Electronics Enclosure end caps (see Section 3.7.1).
9. If required, install the wire seals on the Base Enclosure hex head bolts and on the Shroud covering the meter body (see Section 3.7.2).
10. Install the security wire seals on the shrouds covering the transducers and cables. Refer to the section appropriate for your meter design:
 - Section 3.7.3 Install security seal wires on the shrouds
 - Split shroud security seals
 - Latched band shroud security seals
11. Re-apply electrical power to the system to ensure the field connections are working correctly. After the electrical acceptance test is witnessed and approved, seal the conduit.
12. Set or configure the meter parameters using MeterLink. For additional installation information refer to the system wiring diagram (see Appendix A), *MeterLink Software for Gas and Liquid Ultrasonic Meters Quick Start Manual* (00809-0100-7630) and use MeterLink Field Setup Wizard to complete the configuration.

3.4.2 Startup for systems that use flame-proof cable

⚠ WARNING

HAZARDOUS VOLTAGE INSIDE

Do not open the Transmitter Electronics Enclosure when an explosive gas atmosphere is present. Disconnect equipment from supply circuit before opening.

Failure to remove power may result in serious injury or death.

1. Check to make certain that all field wiring power is turned **OFF**.
2. Remove the end cap nearest the cable entries to gain access to the transmitter electronics.
3. Install the cable and cable gland.
4. Complete the field connection wiring (see [Figure 3-3](#)).
5. Connect a flow computer to the communications line on the meter.
6. Apply electrical power to the system to ensure the field connections are working correctly. After the electrical acceptance test is witnessed and approved, seal the conduit.
7. Power down the system and apply the sealing compound to the conduit and allow to set in accordance with manufacturer specifications.
8. Install the security latches and wire seals on the Transmitter Electronics Enclosure end caps (see [Section 3.7.1](#)).
9. Install the sealing wires and lead seals on the Base Enclosure hex head bolts and on the shroud covering the meter body (see [Section 3.7.3](#)).
10. Install the sealing wires and lead seals on the shrouds covering the transducers and cables. Refer to the section appropriate on the shrouds covering the transducers and cables. Refer to the section appropriate for your meter design:
 - [Split shroud security seals](#)
 - [Latched band shroud security seals](#)

Note: Other types of wire sealing devices are also commercially available and may be used.
11. Connect electrical power to the system.
12. Set or configure the meter parameters using MeterLink. For additional installation information refer to the system wiring diagram (see [Appendix A](#)), *MeterLink Software for Gas and Liquid Ultrasonic Meters Quick Start Manual* (00809-0100-7630) and use MeterLink Field Setup Wizard to complete the meter configuration.

3.5 Wiring and I/O

MeterLink uses the TCP/IP protocol to communicate with the 960-24™ MSTs electronics instead of Modbus ASCII or RTU. The TCP/IP protocol only works across either Ethernet, RS-485 full duplex (4-wire), RS-485 half duplex (2-wire) or RS-232. MeterLink can communicate with multiple meters if they are multi-dropped using 4-wire full duplex RS-485 mode. The meter electronics are HART® capable and provide communication flexibility with Rosemount 3810 Series Liquid Ultrasonic Flow Meters.

Note: Port B for RS-485 full duplex communication is not supported.

The HART® output provides communication with other field devices (e.g., 475/375 Field Communicator and AMST™ Device Manager software) and ultimately, communicates key diagnostic information through PlantWeb® architecture.

NOTICE

If not using Ethernet, a full duplex serial connection is necessary for MeterLink to communicate with a Rosemount 3810 Series Liquid Ultrasonic Flow Meter.

The meter's electronics auto-detects the protocol used and automatically switches between TCP/IP, Modbus ASCII, and Modbus RTU so it is not necessary to make any meter configuration changes to change the protocol.

3.5.1 CPU Module labeling and LED indicators

The meter's metrology mode and the status of the data transfer from the Acquisition Module to the CPU Module is indicated via light-emitting diode (LED) status indicators. The **WRITE PROT.** switch protects the meter's configuration. Move this switch to the **OFF** position to make changes to the meter parameters.

Figure 3-4 CPU Module labeling and LED indicators

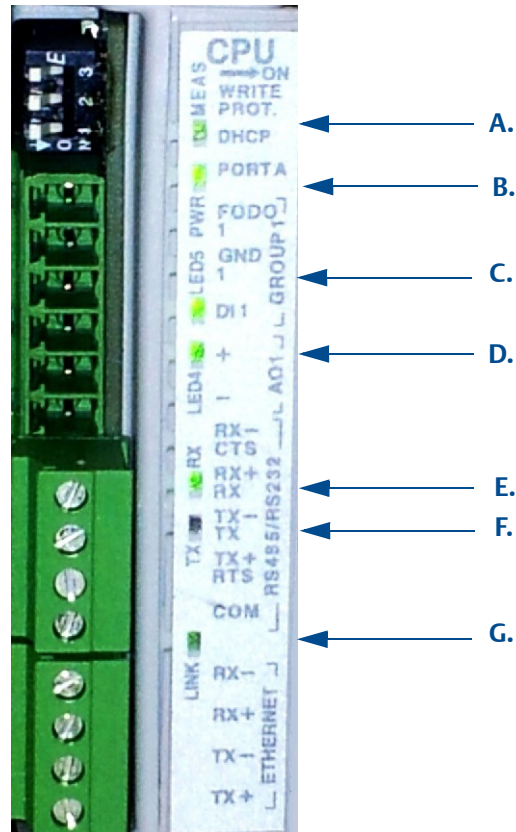

- A. LED 1 - Measurement mode
- B. LED 2 - Power
- C. LED 5 - not used
- D. LED 4 - not used
- E. LED 3 - RX (RS-485/RS-232) - receiving data
- F. LED 6 - TX (RS-485/RS-232) - transmitting data, RS-485 2-wire half duplex use TX+ and TX-
- G. LED 7 - Link (Eth1 Link) - Ethernet connection

Table 3-2 CPU Module labeling and LED functions

CPU Module label	Function	Switch position indicator or LED
WRITE PROT. (Switch 3)	<ul style="list-style-type: none"> Write-protect mode - with switch in the ON position (default setting) protects configuration and firmware overwrites. To write configuration changes or download firmware to the meter change the switch to the OFF position 	Switch position <ul style="list-style-type: none"> ON - (default setting) enables write-protection of the configuration and firmware OFF - enables writing configuration changes or downloading firmware
DHCP (Switch 2)	<ul style="list-style-type: none"> Dynamic Host Protocol Server - enables you to communicate with a Rosemount™ Ultrasonic meter that is not connected to a network. When the CPU Module switch is in the ON position, the meter is enabled to act as a DHCP server for a single DHCP client connected to the Ethernet port using a crossover cable. This should be used for peer to peer connections only. When the connection is made, select to use the Meter Name in the meter instead of the Meter Directory Name in order to keep all log files and configurations separate from each meter. 	Switch position <ul style="list-style-type: none"> ON - the meter is enabled to act as a DHCP server for a single DHCP client OFF - disables the DHCP server
PORT A (Switch 1)	<ul style="list-style-type: none"> PORT A override - RS-232 serves as an override during meter commissioning to establish communications and in the event the user cannot communicate with the meter due to an inadvertent communication configuration change. The override period is for two minutes Supports: <ul style="list-style-type: none"> auto-detected ASCII (Start bit 1, Data Bit 7, Parity Odd/Even, Stop Bit 1) RTU (Start Bit 1, Data Bit 8, Parity none, Stop Bit 1). Modbus protocols RS-232 Baud rate=19,200 Modbus ID=32 	Switch position <ul style="list-style-type: none"> ON - enables RS-232 PORT A override OFF - (default setting) disables RS-232 PORT A
MEAS (LED 1)	System color indicates metrology mode <ul style="list-style-type: none"> Acquisition mode Measurement mode 	LED status <ul style="list-style-type: none"> Red flashing LED Solid red the Acquisition Module not communicating with the CPU Module Green flashing LED
PWR (LED 2)	<ul style="list-style-type: none"> 3.3V Power Indicator 	<ul style="list-style-type: none"> Solid Green
LED 4	<ul style="list-style-type: none"> Not used 	
LED 5	<ul style="list-style-type: none"> Not used 	
RX (LED3)	<ul style="list-style-type: none"> RX signal (Port A for RS485 or RS232 communication) receiving data 	<ul style="list-style-type: none"> Flashing green (when receiving data)
TX (LED6)	<ul style="list-style-type: none"> TX signal (Port A for RS485 or RS232 communication) transmitting data TX+ and TX- (Port A) for RS-485 2-wire communication) 	<ul style="list-style-type: none"> Flashing green (when transmitting data)
LINK (LED 7)	<ul style="list-style-type: none"> ETH1Link user Ethernet connection 	<ul style="list-style-type: none"> Solid green

Ethernet communications

The Ethernet port IP address, subnet mask, and gateway address are software-configurable. In addition, a meter can be configured to act as a DHCP (Dynamic Host Configuration Protocol) server to assign an IP address to a PC or laptop running MeterLink. The DHCP server facility is not intended to act as a general purpose DHCP server for a wider network. To this end, no user control is provided over the class or range of IP addresses the unit provides. A standard twisted pair (Cat-5) cable should be used for Ethernet wiring.

It is strongly recommended that the meter be configured using an independent (off-network) single host. After configuration of the meter, the DHCP option must be turned off if used on a LAN/WAN.

⚠ CAUTION

RESTRICT ETHERNET AND SERIAL CONNECTIVITY USAGE

Failure to restrict Ethernet and communication access to the Rosemount 3810 Series Liquid Ultrasonic Flow Meter can result in, among other things, unauthorized access, system corruption, and/or data loss.

User is responsible for ensuring that physical access and Ethernet or electronic access to the Rosemount 3810 Series Liquid Ultrasonic Flow Meter is appropriately controlled and any necessary security precautions, such as, establishing a firewall, setting password permissions and/or implementing security levels.

Use ethernet cable (Rosemount P/N 3-3400-079) to connect the PC to the meter. **Table 3-3 Ethernet cable to PC communication**

Ethernet communication	
Wire color	CPU
White w/orange stripe	TX+
Orange	TX -
Green w/white stripe	RX+
Green	RX -

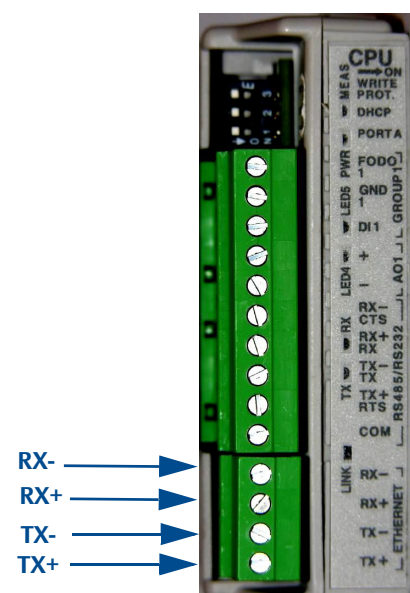

The diagram shows a vertical DIN 41612 48-pin connector. The top half is green and the bottom half is grey. Labels on the right side of the connector include: CPU, MEAS, WRITE PROT., DHCP, PORT A, FODO, GND, DI1, LED4, RX, TX, RX-, RX+, TX-, TX+, COM, LINK, RX-, RX+, TX-, TX+. Blue arrows point to the four pins in the bottom half of the connector, labeled RX-, RX+, TX-, and TX+.

A DIN 41612 48-pin connector is the interface from the CPU Module to the Field Connection Board (male end located on the back of the Field Connection Board).

Serial connections

Use serial cable (Rosemount P/N 3-2500-401) to connect to a PC running MeterLink. The cable is designed for RS-232 communications which is the serial Port A default configuration (see Appendix A field wiring diagram, Rosemount Drawing DMC - 004936). The DB-9 end of the cable plugs directly into the PC running MeterLink. The three wires on the other end of the cable connect to the CPU Module. The RED wire goes to RX, the WHITE wire goes to TX, and the BLACK wire goes to COM for the RS-485/RS-232 (Table 3-4 for Port A wiring). RS-485, 2-wire connection on Port A, uses TX+ and TX- on the CPU and has a ground wire.

When Belden wire No. 9940 or equivalent is used, the maximum cable length for RS-232 communications at 9600 bps is 88.3 meters (250 ft.) and the maximum cable length for RS-485 communication at 57600 bps is 600 meters (1970 ft.).

Port A supports a special override mode which forces the port to use known communication values (19200 baud, address 32, RS-232). Note that the protocol is auto-detected. This mode is expected to be used during meter commissioning (to establish initial communication) and in the event that the user cannot communicate with the meter (possibly due to an inadvertent communication configuration change). Alternately, when using MeterLink™ with an Ethernet port, use Ethernet cable (Rosemount P/N 3-3400-079) to connect the PC.

Table 3-4 Serial Port A parameters

Port/Communication	Description	Common features
Port A (Standard) <ul style="list-style-type: none"> • RS-232 • RS-485 Half Duplex • RS-485 Full Duplex • RS-485¹ (2-wire communication on Port A.) 	<ul style="list-style-type: none"> • Typically used for general communications with a flow computer, RTU (Modbus slave) and radios. • Special override mode to force port configuration to known settings. • Supports RTS/CTS handshaking with software-configurable RTS on/off delay times. • Factory default is RS-232, Address 32, 19200 baud. 	<ul style="list-style-type: none"> • Communications via MeterLink using RS-232 or RS-485 Full Duplex • Software configurable Modbus Address (1-247) • Auto-detects TCP/IP and ASCII or RTU Protocol <ul style="list-style-type: none"> – ASCII Protocol: <ul style="list-style-type: none"> Start Bits = 1, Data Bits=7² – Parity: odd or even 1, Stop Bits =1² – Baud Rates: 1200, 2400, 9600, 19200, 38400, 57600, 115000 bps – RTU Protocol: <ul style="list-style-type: none"> Start Bits = 1, Data Bits=8² – Parity: none, Stop Bits = 1² – Baud Rates: 1200, 2400, 9600, 19200, 38400, 57600, 115000 bps
Ethernet	<ul style="list-style-type: none"> • Preferred port for diagnostic communication via MeterLink • 10 Mbps/100 Mbps 	<ul style="list-style-type: none"> • Modbus TCP/IP

1. RS-485 2-wire connections use TX+ and TX- on the CPU Module

2. Denotes auto-detected protocols.

NOTICE

If not using Ethernet, a full duplex serial connection is necessary for MeterLink to communicate with a Rosemount 3810 Series Liquid Ultrasonic Flow Meter.

Figure 3-5 PC to meter serial connection wiring

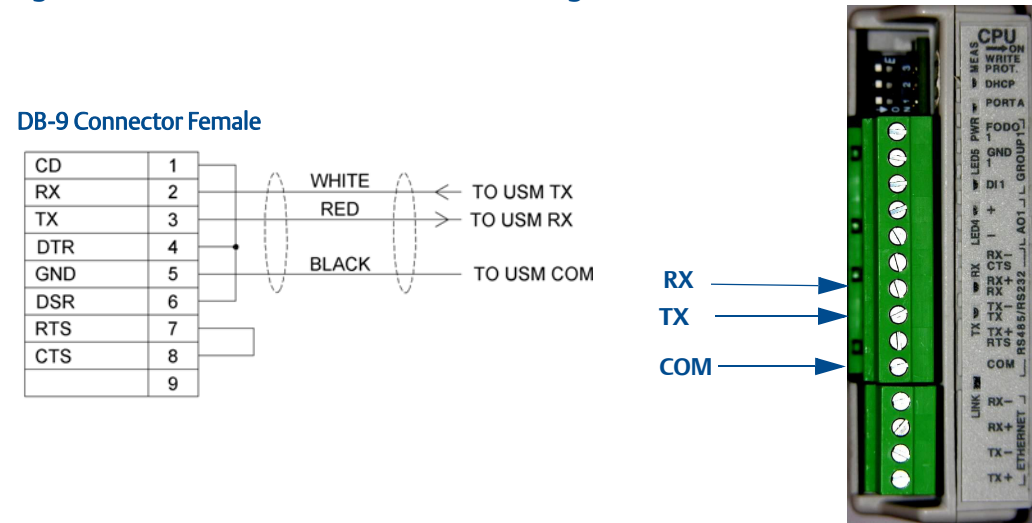

3.6 I/O connections

The meter provides the I/O connections on the CPU Module.

Figure 3-6 CPU Module I/O connections

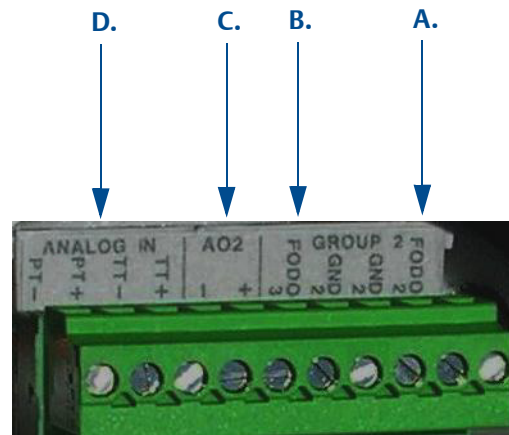

- A. Frequency/Digital Output 2
- B. Frequency/Digital Output 3
- C. Analog Output 2, 4-20mA output
- D. Analog Input - temperature and pressure connections

3.6.1 Frequency/Digital outputs

The meter has three user-configurable selections for configuring either a Frequency output or Digital output (FODO).

- FODO1 (four possible parameter configurations)
- FODO2 (eight possible parameter configurations)
- FODO3 (eight possible parameter configurations)

Frequency or Digital Outputs (FODO 1) source

- FO1A, DO1A, FO1B, DO1B
- Frequency output 1A is based on frequency content (Actual - Uncorrected Flow Rate)
- Frequency output 1B is based on frequency content and Frequency 1 B Phase
- Digital output 1A is based on Digital output1A content (Frequency1A Validity and Flow Direction)

Frequency or Digital Outputs (FODO 2) source

- FO1A, DO1A, FO1B, DO1B, FO2A, DO2A, FO2B, DO2B
- Frequency output 1A is based on frequency content (Actual - Uncorrected Flow Rate)
- Frequency output 1B is based on frequency content and Frequency 1B Phase
- Frequency output 2A is based on frequency content (Actual - Uncorrected Flow Rate)
- Frequency output 2B is based on frequency content and Frequency 2B Phase
- Digital output 1A is based on Digital output1A content (Frequency 1A Validity and Flow Direction)
- Digital output 2A is based on Digital output2A content (Frequency 1A Validity and Flow Direction)
- Digital output 2A is based on Digital output 2A content (Frequency 2A Validity and Flow Direction)
- Digital output 2B is based on Digital output 2B content (Frequency 2B Validity and Flow Direction)

Frequency or Digital Outputs (FODO 3) source

- FO1A, DO1A, FO1B, DO1B, FO2A, DO2A, FO2B, DO2B
- FO1A, DO1A, FO1B, DO1B, FO2A, DO2A, FO2B, DO2B
- Frequency output 1A is based on frequency content (Actual - Uncorrected Flow Rate)
- Frequency output 1B is based on frequency content and Frequency 1B Phase
- Frequency output 2A is based on frequency content (Actual - Uncorrected Flow Rate)
- Frequency output 2B is based on frequency content and Frequency 2B Phase
- Digital output 1A is based on Digital output1A content (Frequency 1A Validity and Flow Direction)
- Digital output 2A is based on Digital output2A content (Frequency 1A Validity and Flow Direction)
- Digital output 2A is based on Digital output 2A content (Frequency 2A Validity and Flow Direction)
- Digital output 2B is based on Digital output 2B content (Frequency 2B Validity and Flow Direction)

Mode options

- Open Collector (requires external excitation supply voltage and pull-up resistor)
- TTL (internally powered by the meter 0-5 VDC signal)

Channel B Phase options:

- Lag forward, Lead reverse (Phase B lags Phase A while reporting forward flow, leads Phase A while reporting reverse flow)
- Lead forward, Lag reverse (Phase B leads Phase A while reporting forward flow, lags Phase A while reporting reverse flow)

Phase A and Phase B output (based on flow direction)

- Reverse flow - output only reports flow in the reverse direction. For frequency outputs, Phase B of the output is 90 degrees out of phase with Phase A.
- Forward flow - output only reports flow in the forward direction. For frequency outputs, Phase B of the output is 90 degrees out of phase with Phase A.
- Absolute - output reports flow in both directions. For frequency outputs, Phase B of the output is 90 degrees out of phase with Phase A.
- Bidirectional - output reports flow on Phase A only in the forward direction and on Phase B only in the reverse direction.

Maximum frequency for the frequency outputs

- 1000Hz
- 5000Hz

Table 3-5 Frequency/Digital Outputs possible configurations

Frequency/Digital output		Source configuration
Frequency /Digital Output 1 ¹	<ul style="list-style-type: none"> • Frequency output 1A • Frequency output 1B • Digital output 1A • Digital output 1B 	
Frequency /Digital Output 2 ² or	<ul style="list-style-type: none"> • Frequency output 1A • Frequency output 1B • Digital output 1A • Digital output 1B 	
Frequency /Digital Output 3 ²	<ul style="list-style-type: none"> • Frequency output 2A • Frequency output 2B • Digital output 2A • Digital output 2B 	

1. Solid blue line denotes valid selection for Frequency/Digital Output 1.
2. Black dashed -line denotes valid selections for Frequency/Digital Output 2 and Frequency/Digital Output 3.

Output for FODO1 and Digital Output1 (Group 1 on the CPU Module) share a common ground and have 50V isolation. FODO2 and FODO3 (Group 2 on the CPU Module) share a common ground and have 50V isolation. This allows an output to be connected to a different flow computer. The outputs are opto-isolated from the CPU Module and have a withstand voltage of at least 500V rms dielectric.

Figure 3-7 CPU Module - Frequency/Digital outputs common ground

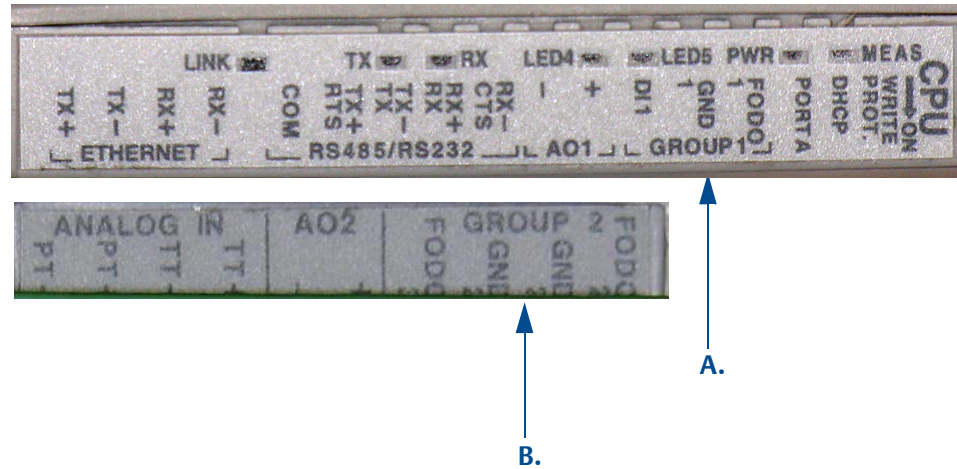

- A. FODO1 and Digital input1 - shared common ground (Group 1)
- B. FODO2 and FODO3 - shared common ground (Group 2)

3.6.2 Analog input settings

The 960-24™ MSTs has the capability to sample analog temperature (Analog Input 1) and pressure (Analog Input 2) with 4-20 mA signals. The two independent analog input circuits are available for conventional 4-20 mA service. The analog inputs may be powered by the internal 24VDC isolated power supply in the meter or powered by an external power source. Refer to the Field Wiring Diagram (see Appendix A drawing DMC004936).

3.6.3 Analog output settings

The 960-24™ MSTs provides two 4-20 mA analog output signals.

- Analog Output 1 (AO1) is used for conventional 4-20mA output or for HART® output support.
- Analog Output 2 (AO2) is used as a conventional 4-20 mA output.

3.6.4 Digital Input

The Rosemount 3810 Series Liquid Ultrasonic Flow Meter provides one digital input that can be used as a general purpose input or used for synchronizing calibration (for flow calibration gating - contact closure). The meter records the volume seen between switch closures. The polarity of the input is configured as normal or inverted polarity.

- polarity is determined by the `IsDI1ForCalActiveLow` and the gating edge is determined by the `IsDI1ForCalStateGated` (calibrate edge gated or calibrate state gated).
- calibration is started and stopped via an **inactive>active** state change.

The digital input must be configured via the MeterLink **Tools | Edit/Compare Configuration** page.

3.6.5 DHCP server switch settings

The meter can be configured to act as a Dynamic Host Configuration Protocol (DHCP) server providing network communication using the Internet Protocol (IP) address. The DHCP server is enabled/disabled via the CPU Module DHCP Switch 1 as follows:

Table 3-6 DHCP server switch settings

CPU Module switch	DHCP server disabled	DHCP server enabled
DHCP	OFF	ON

3.6.6 Configuration protect switch settings

The meter's configuration parameters and firmware can be protected against changes via CPU Module WRITE PROT. switch as follows:

Table 3-7 Configuration protect switch settings

CPU Module switch	Configuration protected	Configuration unprotected
WRITE PROT.	ON (default)	OFF

A complete list of write-protected parameters are in [Appendix B](#).

3.6.7 External power source connection and fuse

Located inside the Transmitter Electronics Enclosure is a connector for a user-provided external power source, a 2 Ampere fuse and a 24V loop power connection for ultrasonic meter analog outputs, generator transmitter or pressure transmitter devices. The current is limited to 88mA.

Figure 3-8 CPU Module power source connections

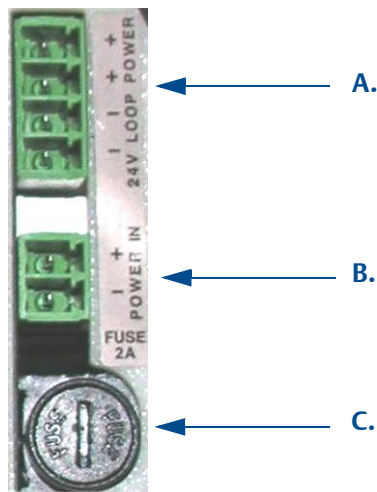

- A. POWER IN connector (main power)
- B. 24V LOOP POWER
- C. 2 Ampere FUSE (used for the main power input)

3.7 Security seal installation

Security seals protect the integrity of the meter metrology and prevent tampering with transducer assemblies. The following sections detail how to properly seal the Rosemount 3810 Series Liquid Ultrasonic Flow Meter after commissioning or maintenance procedures. The security sealing wire, lead seals and seal press tools are commercially available. Other types of wire sealing devices are also commercially available and may be used.

WARNING

CUTTING HAZARD

Sharp edges may be present on the band shrouds.

Wear appropriate personal protective equipment when working on the meter. Failure to do so may cause serious injury.

Be sure to set the **WRITE PROT.** switch on the CPU Module to the **ON** position prior to sealing the enclosure.

Use [Table 3-8](#) to seal the meter electronics and the shroud installed on your meter.

Table 3-8 installing wire seals on the meter

Seal the meter	<ul style="list-style-type: none">• 3.7 Security seal installation• 3.7.1 Install security seal wires on the Transmitter Electronics Enclosure• 3.7.2 Install security seal wires on the Base Electronics Enclosure• 3.7.3 Install security seal wires on the shrouds
----------------	--

3.7.1 Install security seal wires on the Transmitter Electronics Enclosure

Use the following instructions to install the security seal wires on the Transmitter Electronics Enclosure.

Figure 3-9 Transmitter electronics enclosure security latch

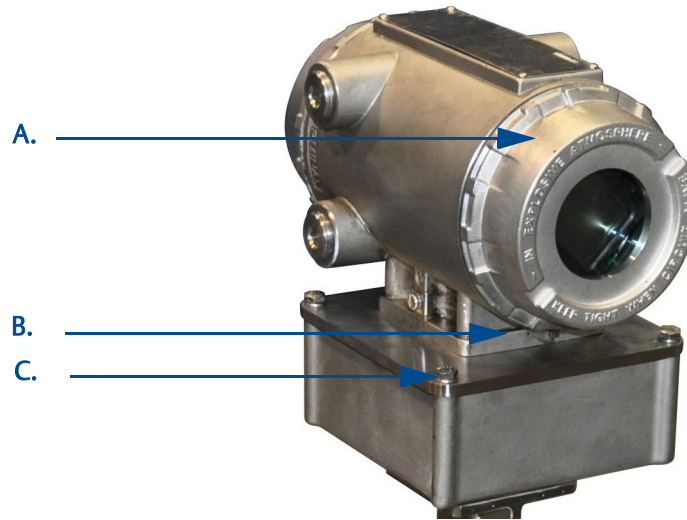

- A. Transmitter Electronics Enclosure end cap security seal hole location
- B. Security latch
- C. Base cover bolt with security seal holes

Procedure

1. Rotate the end cap clockwise fully closing and compressing the end cap seal. Install the Security latch using a 3mm Allen wrench.
2. Install the security seal wire into and through one of the two holes in the end cap. Choose holes that minimize counterclockwise rotation of the end cap when the security wire is taut (maximum wire diameter .078 inch; 2.0mm).

Figure 3-10 Transmitter Electronics Enclosure security seals

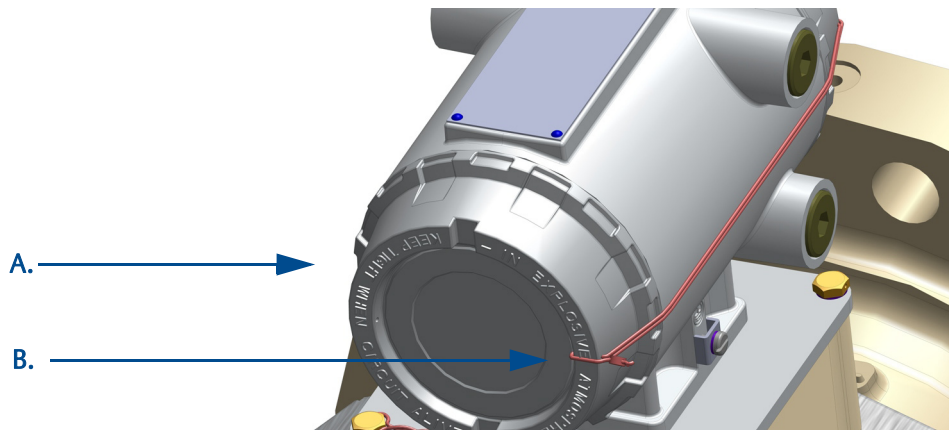

- A. Transmitter Electronics Enclosure end cap
- B. Security wire seals

3. Adjust the security wire, removing all slack and thread into the lead seal.
4. Cut wire ends to remove excess wire.

3.7.2 Install security seal wires on the Base Electronics Enclosure

Use the following instructions to install the security seal wire on the Base Enclosure.

Procedure

1. Install security wire seal into and through two of the four the holes in the socket head screws on the Base Enclosure cover (maximum wire diameter .078 inch; 2.0mm).

Figure 3-11 Base Enclosure security seals

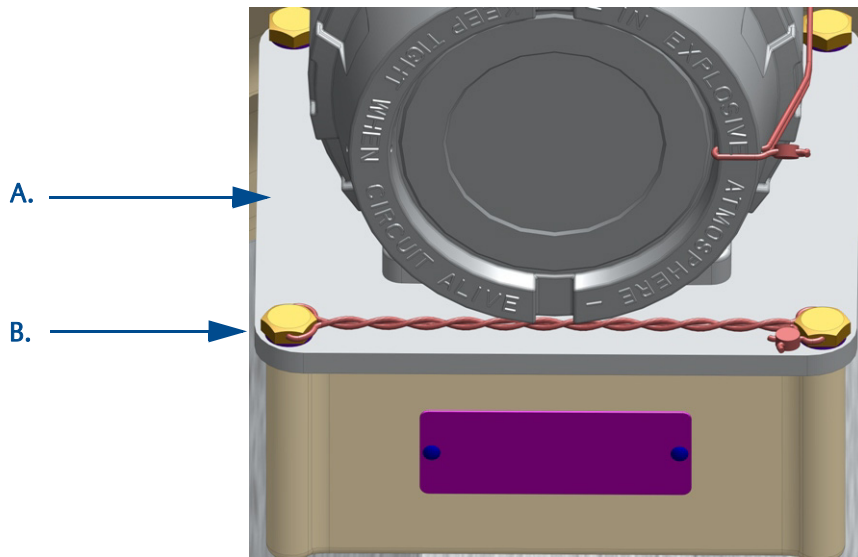

- A. Base Enclosure
- B. Security wire seals

2. Position the wire to prevent counterclockwise rotation of the screws when the seal wire is taut.
3. Twist and adjust wire removing all slack and seal.
4. Cut wire ends to remove excess wire.

3.7.3 Install security seal wires on the shrouds

Use the following instructions to install the security seal wires on the split shroud covering the meter body and transducer assemblies.

Split shroud security seals

Figure 3-12 Split shroud security seals

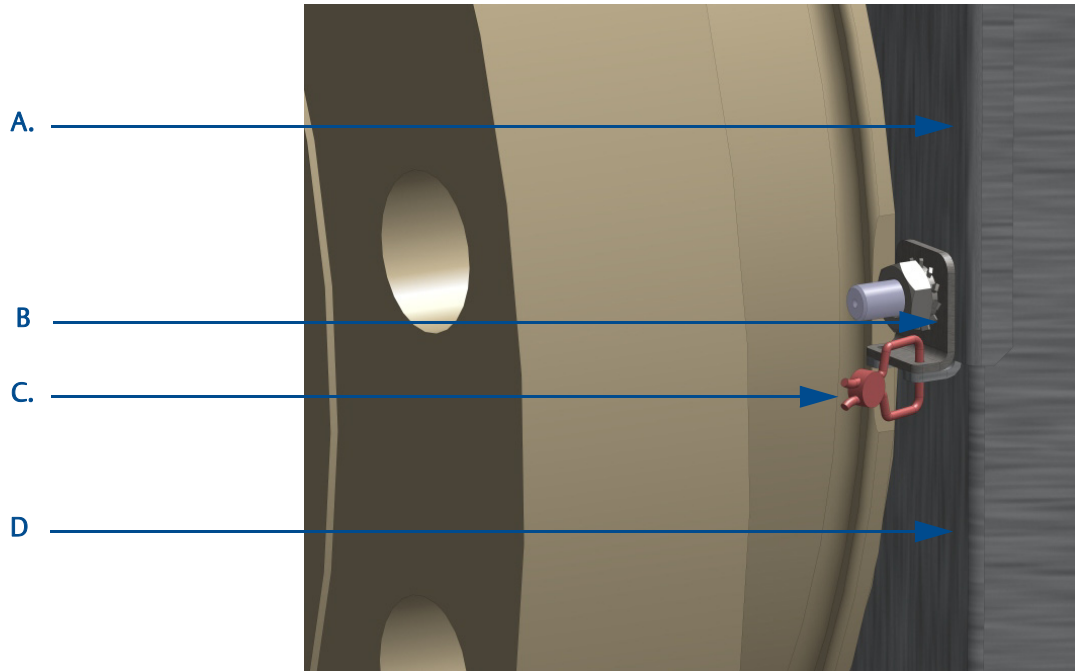

- A. Upper split shroud
- B. Split shroud clamp
- C. Security wire seals
- D. Lower split shroud

Procedure

1. Install the security seal wire into and through the holes in the split shroud clamp bent tab and the upper split shroud bent tab. (maximum wire diameter .078 inch; 2.0 mm).
2. Remove all slack and seal.
3. Cut wire ends to remove excess wire.
4. Repeat these steps for the other split shroud clamps.

Latched band shroud security seals

Use the following instructions to install the security seal wires on the latched band shrouds covering the meter body and transducer assemblies.

If your meter has shrouds which have two or more latches, repeat the security seal procedure for each latch on all of the shrouds.

Figure 3-13 Latched single band shroud assembly

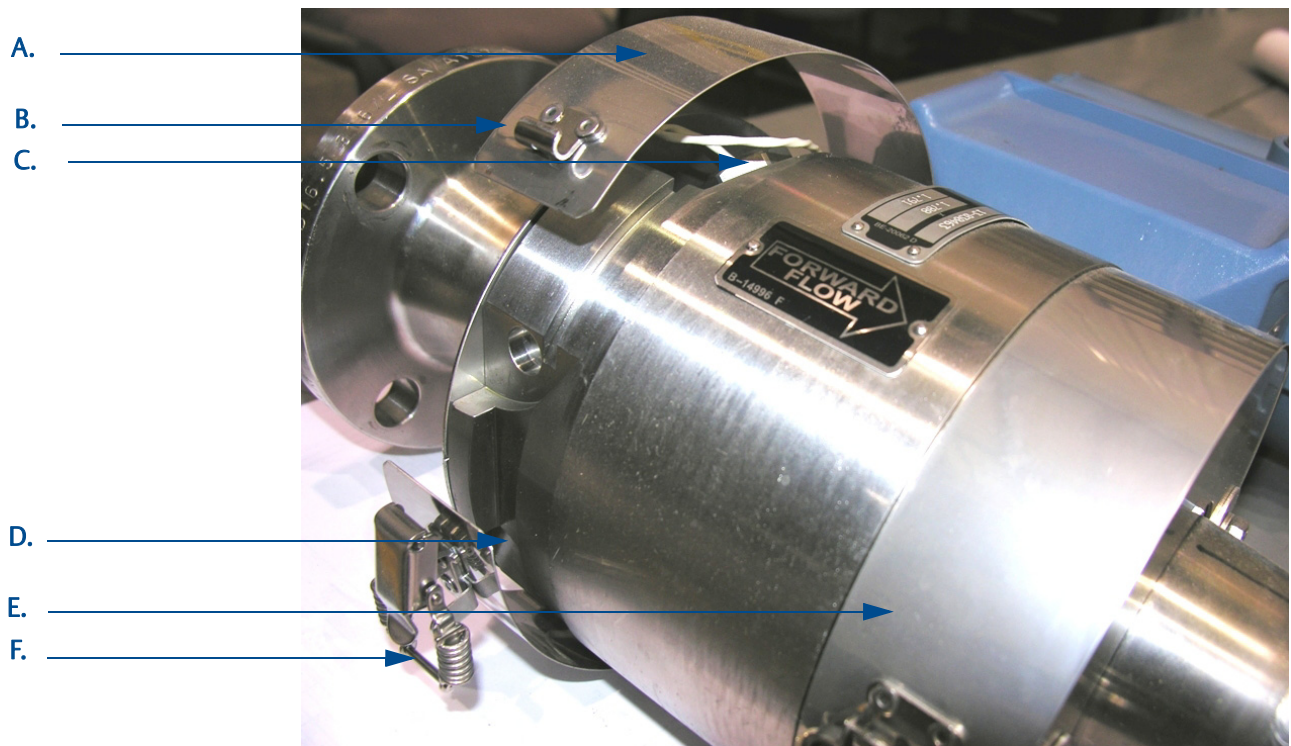

- A. Band shroud
- B. Strike
- C. Transducer cable
- D. Meter body latch pocket for rivet clearance
- E. Meter body shoulder
- F. Shroud latch

Figure 3-14 Liquid Ultrasonic Flow Meter assembly with latched double band shrouds

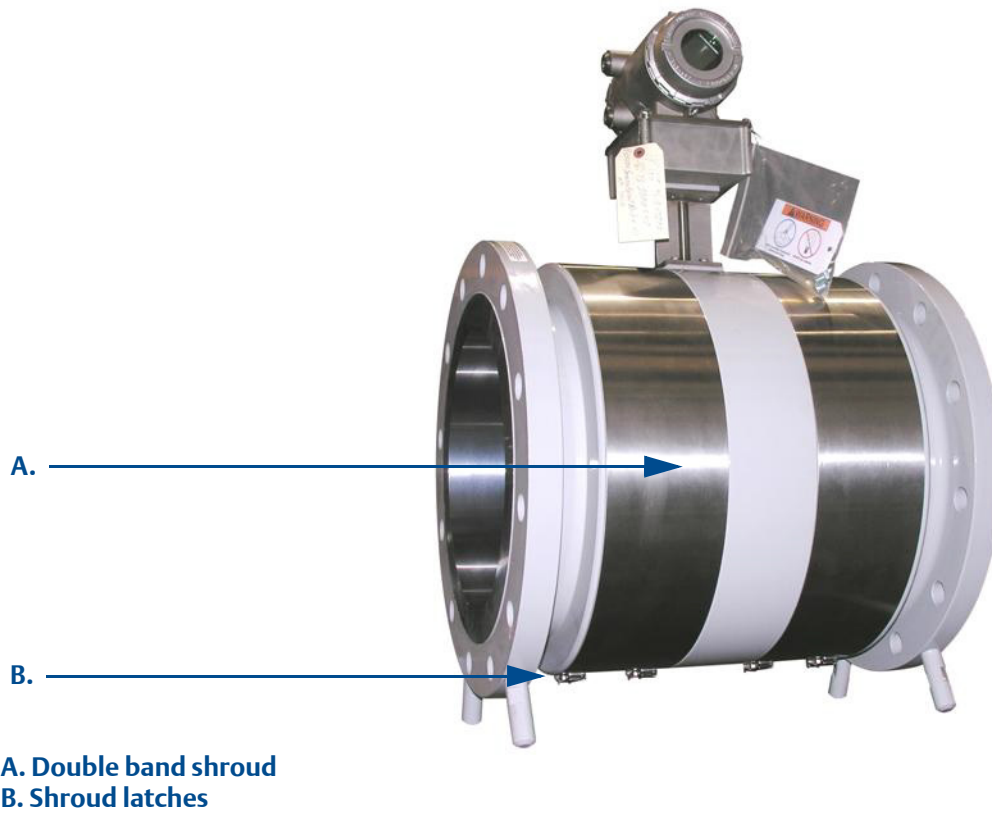
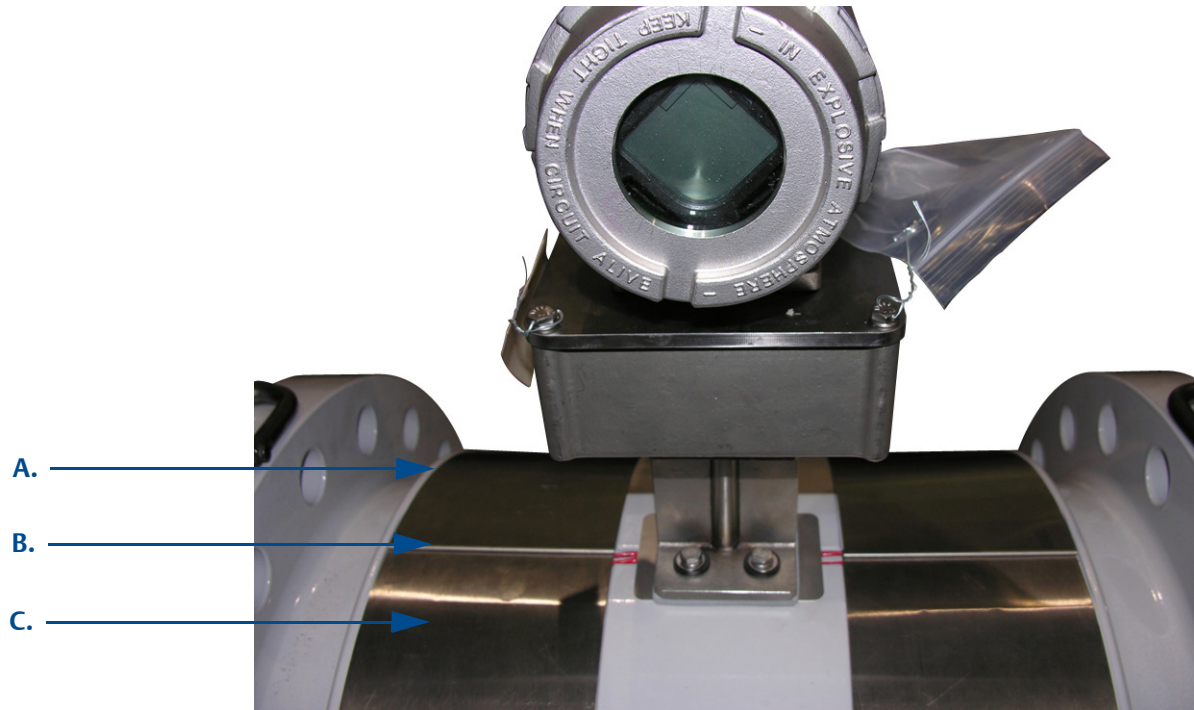

Figure 3-15 Liquid Ultrasonic Flow Meter assembly with latched double band shrouds



- A. Back band shroud
- B. Shroud hem bend
- C. Front band shroud

Procedure

1. Install the security seal wire into and through the holes in all of the shroud latches (maximum wire diameter .078 inch; 2.0 mm). Four holes are provided per latch to allow sealing wire to loop around latch lever.

Figure 3-16 Shroud latch holes for security wire seals



A. Latch retainer holes for security wire seals

2. Remove all slack and seal.
3. Cut wire ends to remove excess wire.
4. Repeat these steps for the remaining shroud latches on each band shroud.

3.7.4 Seal conduit ports

The unit should be properly sealed with a sealing compound after electrical connections have been tested according to the customer's Best Practices schedule. Verify all electrical connections are correct, that the meter is accurately measuring flow and that the meter meets the customer's installation requirements. [See Section 3.4.1](#) and [Section 3.4.2](#).

Section 4: Commission and startup

High temperature applications use an extended mounting bracket to raise the transmitter electronics from the meter body. The following sections discusses pre- installation considerations for the meter.

4.1 Pre-installation considerations

1. Clear the area of obstructions or debris.
2. Ensure all personnel wear Personal Protective Equipment appropriate for the installation tasks.
3. Ensure all equipment handling and lifting safety procedures are followed and personnel are qualified to operate the equipment.
4. Make sure personnel have read and understood the Rosemount 3810 Series Liquid Ultrasonic Flow Meter Installation Manual and observe all labels affixed to the meter.
5. Observe the flow direction arrow label on the meter and ensure the meter is correctly oriented in the pipeline.
6. Ensure the site the piping configuration design and installation allows for optimal flow measurement.
7. Review site pipe and ID drawings with elevations.
8. Check the meter bore and make sure it is free of debris.
9. If required for lifting, ensure the safety engineered swivel hoist rings are appropriate for the weight of the meter. Use appropriately rated lifting slings. Do not allow the slings to make contact with the transmitter electronics enclosure (see [Section 2.4](#) through [Section 2.4.4](#)).
10. Ensure meter flange bolts are tightened and the alignment is accurate. All meter designs, except 3812, have knockout dowel pin holes provided in the meter body flanges. If mating flanges are machined with matching dowel pin holes, dowel pins, two per flange, can be installed to assist with correctly aligning the meter body and pipings. Once flange bolt up is completed it is recommended to remove the dowel pins to avoid dowel pin corrosion.
11. Review site wiring diagrams.
12. Have information and manuals for all other flow instrumentation; flow computers, pressure and temperature transmitter data sheets, and wiring.
13. Have a working knowledge of shutoff and control valve information, specifications, operation and setup data.
14. Ethernet (Cat 5 cables) or serial cables to link the laptop to the meter.
15. Run the conduit for field wiring according to the Operator's specifications. Check all ultrasonic meter wiring for good contact at all terminations and confirm that the transmitter is wired according to the Rosemount 3810 Series Field Wiring Diagram (DMC-004936, [Appendix A](#)).
16. Check the switch settings PORT A override (1), DHCP server enable (2) WRITE PROT. (3) on the transmitter CPU Module are in the correct position.
17. Have the Emerson service representative's contact information and telephone numbers for major components; valves, meter, flow computer, communication gear, transmitters, site designers or integrators.

4.2 Meter commissioning and startup

1. Observe all site standard operating safety precautions, important safety instructions in the Preface of this manual, warning labels and the following:
 - transporting, handling and lifting the meter, safety engineered swivel hoist rings and slings (see Section 2.4 through see Section 2.4.4).
 - commissioning electrical connections in hazardous environments
 - personal protective equipment requirements
2. Complete the field wiring (see Section 3.5 and Section 3.6)
3. Have access to a laptop with MeterLink software installed.
4. Apply power to the meter.
5. Establish flow in the meter (at least 3 feet per second to ensure good thermal mixing).
6. Start MeterLink.
7. Add, edit or import a Meter Directory record and setup communications parameters for the meter.
8. Save the meter's configuration file; your **As Found** record of the meter. In MeterLink, select **Tools | Edit/Compare Configuration**. Click the **Read** button and select **File Save**.
9. If desired, open **Program Settings** and customize MeterLink.
10. Open **Meter Monitor (Detailed)** view and check the measurement paths or chords and that they agree with each other to approximately 0.2%.
11. Check for **Status** alarms that may be present. If an alarm status is indicated, click **Check Status**, to view the Status Summary dialog. Click the **question mark** next to the alarm description to assist you with resolving and clearing alarms.
12. Check for good signal strength (usually shown as SNR or, Signal to Noise Ratio).
13. Check for reasonably correct flow profile.
14. Collect and save a Maintenance Log to record the initial performance of your meter (this is your **As Found** record).
15. Use the Field Setup Wizard to make any configuration adjustments, such as setting the units of measure, frequency/digital output, frequency, digital and current outputs and other meter parameters.
16. Save another Maintenance Log; this is your **As Left** record.

Section 5: Configuration

After the mechanical and electrical installation is complete and connectivity is established, use the *MeterLink Software for Gas and Liquid Ultrasonic Meters Quick Start Manual* (00809-0100-7630) to setup initial communications with the meter.

5.1 MeterLink setup

1. Review the software operating system, hardware and peripheral requirements.
2. Follow the installation instructions for your operating system (Windows® XP, Windows Vista, Windows® 7 or Windows® 8).
3. Configure a direct connection driver for first time modem configuration for MeterLink communications.
4. Click the MeterLink desktop icon and complete the information in the Registration Wizard. This wizard will appear the when you first run MeterLink and will provide you the following options.

Options:
Register by e-mail <ul style="list-style-type: none">• Select this option and click Next to register by e-mail. Your machine must be connected to the Internet and have a default mail utility (i.e. Microsoft® Office Outlook®, Outlook® Express, etc.) configured to use this option.
Register by phone <ul style="list-style-type: none">• Select this option to register by phone. After clicking Next, a page will display with phone numbers to dial.
Register later (remind me) <ul style="list-style-type: none">• Select this option if you do not wish to register now, but would still like the wizard to appear the next time you run MeterLink.
Register later using the Help Register Program menu item (don't remind me) <ul style="list-style-type: none">• Select this option if you do not wish to register now and do not want this wizard to appear the next time you run MeterLink. You can still register at a later time by selecting Register Program from the Help menu

5. Select **File | Program Settings** and customize the user-preferences (e.g. User name, Company name, display units, Liquid Meter volume units and other interface settings)
6. Connect to your meter. If your meter is not shown in the list, select **Edit Meter Directory** and setup the connections properties.
7. Run the Field Setup Wizard.

5.2 Field Setup Wizard

1. Use the Field Setup Wizard-Startup Page and select the checkboxes that allow proper configuration for your meter (Temperature, Pressure, Meter Corrections, and Meter Outputs). Selections on this page will affect other configuration selections. Select **Next** to continue to General setup.
2. On General setup page configure the meter's system units (U.S Customary or Metric units) volume units, flow rate time, low flow cutoff, contract hour and enable reverse flow. Click **Next** to continue to Frequency Outputs.
3. Configure Frequency output 1 and Frequency output 2 content (Rosemount™ Liquid Ultrasonic Meters content is Uncorrected flow rate), flow direction, Channel B phase, maximum frequency output (Hertz) and Full scale volumetric flow rate. Click **Next** to continue to Meter Digital Outputs.
4. Select the Meter Digital Output parameters for Digital output 1A, Digital output 1B, Digital output 2A and Digital output 2B based on Frequency validity or flow direction. If the output of the ultrasonic meter is reversed from what a flow computer is expecting, select Inverted Operation. This changes the digital output from a HIGH for a TRUE condition to output a LOW for a TRUE condition. Click **Next** to continue to Current Outputs.
5. Current Outputs are based on Uncorrected (Actual) flow rate) content, flow direction (Forward, Reverse or Absolute) and Full scale volumetric flow rate used with output (20mA maximum). Alarm action parameters determines the state the output will drive during an alarm condition (High 20mA, Low - 4 mA, Hold last value, Very low - 3.5, Very high 20.5 mA or None). Click **Next** to continue to configure the HART® Output(s) parameters.
6. HART® Output parameters include four Dynamic process variables (Primary, Secondary, Third and Fourth variable. The Primary variable is set to match the Content set for Current output 1. If a second current output is available, the Secondary variable is set to match the Content set for Current output 1) Identification and HART® units (volume units, Flow rate time units, Velocity units, Pressure and Temperature units). Click **Next** to continue to Temperature and Pressure.
7. Set the temperature and pressure scaling for analog inputs, enter fixed values, and set alarm limits for both. **Next** to continue to configure the Local Display parameters.
8. Configure the parameters for the local display. Use the drop-down arrow in the Display Items list box and select or modify the Display items, the Display units and the Scroll delay.

Display Items

The valid labels, descriptions and units for the shown below:

Table 5-1 Local display labels, descriptions and valid units

Local Display labels, descriptions and units
QFLOW – Uncorrected volume flow rate <ul style="list-style-type: none">• BBL – Barrels• GAL – Gallons• L – Liters• CM – Cubic Meters• MCM – Thousand Cubic Meters
TDYVL – Current day’s forward uncorrected volume <ul style="list-style-type: none">• +BBL – Barrels• +GAL – Gallons• +L – Liters• +CM – Cubic Meters• +MCM – Thousand Cubic Meters
TDYVL – Current day’s reverse uncorrected volume <ul style="list-style-type: none">• -BBL – Barrels• -GAL – Gallons• -L – Liters• -CM – Cubic Meters• -MCM – Thousand Cubic Meters
YSTVL – Previous day’s forward uncorrected volume <ul style="list-style-type: none">• +BBL – Barrels• +GAL – Gallons• +L – Liters• +CM – Cubic Meters• +MCM – Thousand Cubic Meters
YSTVL – Previous day’s reverse uncorrected volume <ul style="list-style-type: none">• -BBL – Barrels• -GAL – Gallons• -L – Liters• -CM – Cubic Meters• -MCM – Thousand Cubic Meters
TOTVL – Forward uncorrected volume <ul style="list-style-type: none">• +BBL – Barrels• +GAL – Gallons• +L – Liters• +CM – Cubic Meters• +MCM – Thousand Cubic Meters
TOTVL – Reverse uncorrected volume <ul style="list-style-type: none">• -BBL – Barrels• -GAL – Gallons• -L – Liters• -CM – Cubic Meters• -MCM – Thousand Cubic Meters

Table 5-1 Local display labels, descriptions and valid units

Local Display labels, descriptions and units	
VEL – Average flow velocity	<ul style="list-style-type: none">Ft/S – Feet per secondM/S – Meters per second
SOS – Average sound velocity	<ul style="list-style-type: none">Ft/S – Feet per secondM/S – Meters per second
TEMP – Flow-condition temperature	<ul style="list-style-type: none">DEGF – Degrees FahrenheitDEGC – Degrees Celsius
PRESS – Flow-condition pressure	<ul style="list-style-type: none">PSI – Pound per square inchMPA – Megapascals
FRQ1A – Frequency channel 1A	<ul style="list-style-type: none">HZ – Hertz
FRQ1B – Frequency channel 1B	<ul style="list-style-type: none">HZ – Hertz
KFCT1 – Frequency 1 K-factor	<ul style="list-style-type: none">BBL – BarrelsGAL – GallonsL – LitersCM – Cubic MetersMCM – Thousand Cubic Meters
FRQ2A – Frequency channel 2A	<ul style="list-style-type: none">HZ – Hertz
FRQ2B – Frequency channel 2B	<ul style="list-style-type: none">HZ – Hertz
KFCT2 – Frequency 2 K-factor	<ul style="list-style-type: none">BBL – BarrelsGAL – GallonsL – LitersCM – Cubic MetersMCM – Thousand Cubic Meters
AO1 – Analog Output 1 current	<ul style="list-style-type: none">MA – Milliamperes
AO2 – Analog Output 2 current	<ul style="list-style-type: none">MA – Milliamperes

Note: When connected to a meter with the optional local display, reverse flow direction is indicated with a minus sign (negative) before the value(s) shown on the display.

Display units

The Meter volume units displayed are either U.S. Customary or Metric. To modify the Display Units, configure the Meter units system in the Field Setup Wizard – General Page.

- U.S. Customary volume unit selections are:
 - Barrels
 - Gallons
- Metric volume unit selections are:
 - Cubic meters
 - Cubic liters
- Display units preceded by a plus or minus sign indicate forward and reverse flow direction.
- The Local Display Flow rate time units are modifiable by selecting the drop-down arrow and clicking the time unit in the list box.
- Valid flow rate time units selections are:
 - second
 - minute
 - hour
 - day

Scroll delay

The Scroll Delay is the time interval for the selected display items to be shown on the Local Display. The default scroll delay setting is five seconds. Click the spin box up or down arrow to increase or decrease the length of time an item displays.

1. Select **Finish** to complete the Field Setup Wizard parameter changes and write the configuration settings to the meter.
2. Save the meter configuration file, collect a Maintenance log and Waveforms to document the “As Left” settings.

5.3 Use AMS Device Manager to configure the meter

This procedure assumes you have AMS Device Manager installed on the host computer and have downloaded the latest Rosemount™ Liquid Ultrasonic Meter Device Description (DD).

If not installed, click the link below to download the AMS device installation tool kit.

<http://www2.emersonprocess.com/en-US/documentation/deviceinstallkits/Pages/deviceinstallkitsearch.aspx>

Procedure - installing AMS Device Description

1. Use the link above to search for the Device Description (DD) for your Rosemount 3810 Series Liquid Ultrasonic Flow Meter.
2. Use the pull-down menu and select the Brand/Manufacturer - **Emerson Industries**.
3. Next select the Device, **Liquid 3810 Series** from the pull-down menu.
4. Choose the **Device Revision 1**, from the pull-down menu.
5. Next, select **HART** from the Communication Protocol menu.
6. Select **AMS Device Manager** for the Host System.
7. Select the **Host System Revision 11.5**.
8. Verify your search parameters are correct, as shown below.

Figure 5-1 AMS Device Description search

Search Device Install Kits

Brand/Manufacturer:
Emerson Daniel Industries

Device:
Liquid 3810 Series

Device Revision:
1

Communication Protocol:
HART

Host System:
AMS Device Manager

Host System Revision:
11.5

SEARCH NOW > [RESET SEARCH]

9. Click **Search Now**.

10. Click the **Rosemount Liquid 3810 Series Rev 1** hyperlink. The file download dialog displays. Click the **Save** button to save the files to your host system. You may use the default download location or change the directory.

11. **AMS file download options**

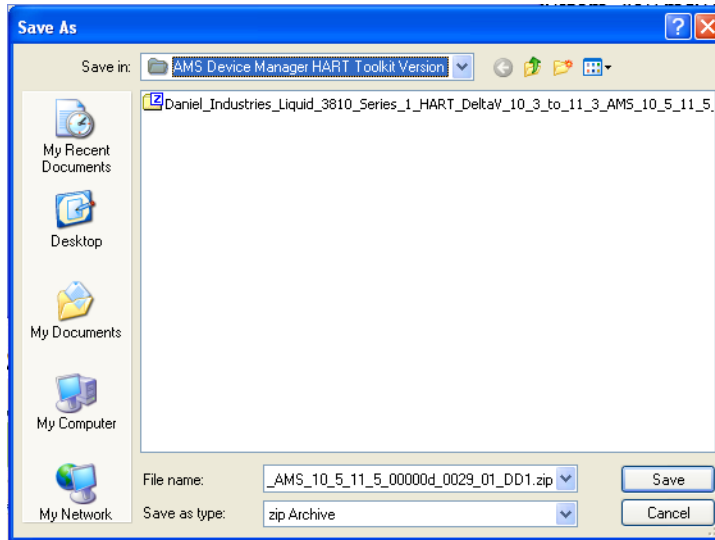

12. Click the **Save** button to complete the file download.

Figure 5-2 AMS file download complete

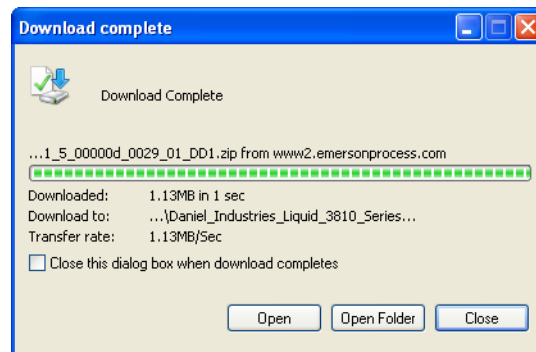

13. Click **Open** or **Open Folder** to view the downloaded files.
14. Establish power to the meter and wiring to Analog Input 1 for HART communication.
15. Start the AMS Device Manager using a laptop or PC.
16. Enter login credentials and click **OK** to launch the application.

17. Click the Configure tab, and then select **Guided Setup**, **Manual Setup** or **Alert Setup**.

Figure 5-3 AMS Device Manager

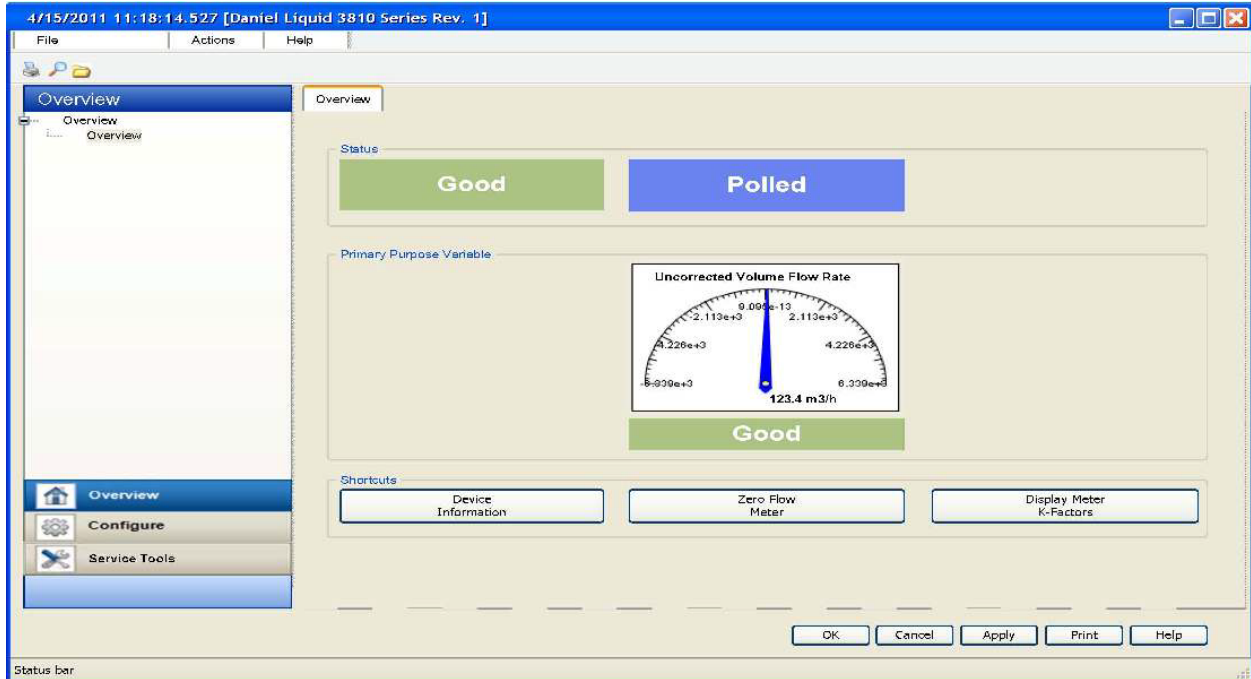
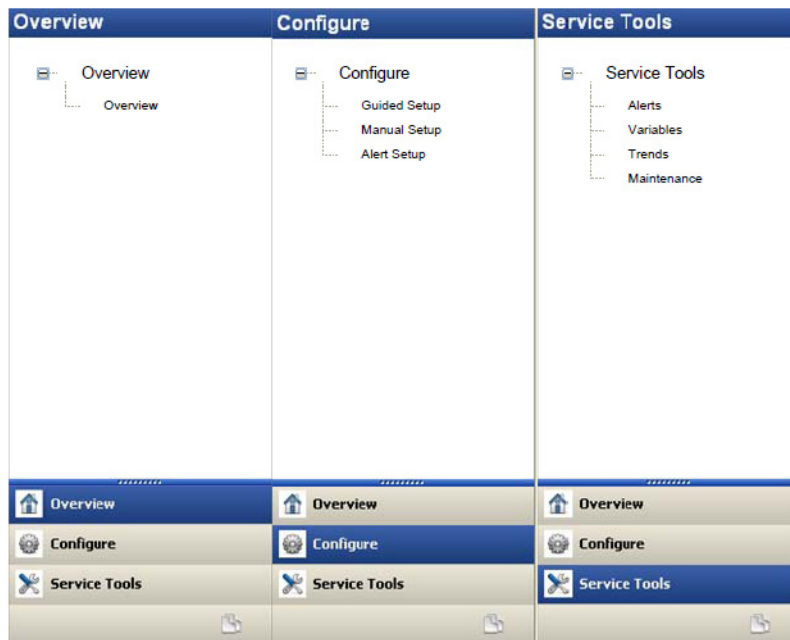

Figure 5-4 AMS Device Manager - Overview



AMS Device Manager - Guided Setup

The Guided setup wizard provides configuration parameter settings for the meter. The Guided Setup is a subset of the Manual Setup parameters.

Figure 5-5 AMS Device Manager - Guided Setup

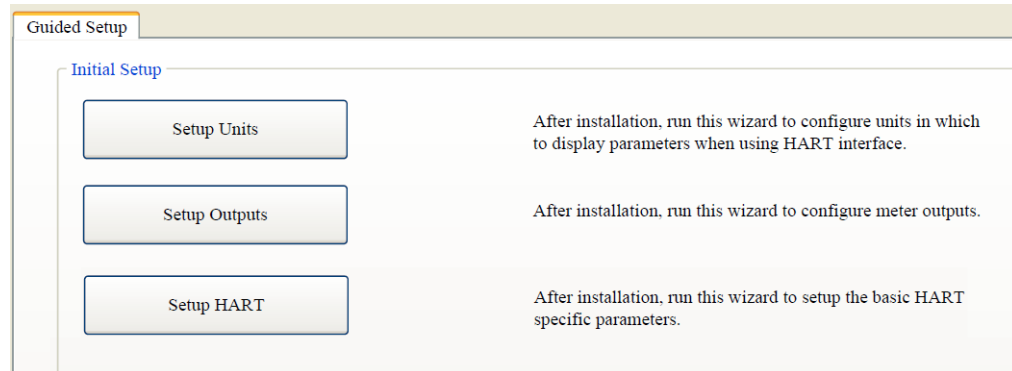

Note: Before writing configuration changes to your meter, make sure you have saved the Configuration file and Maintenance log.

Procedure

1. Disable the Write Protect switch in the CPU Module to write any of the following configuration parameters to your meter.
2. Click the **Setup Units** tab to configure the system units (U.S. Customary or Metric units), Volume units, Flow rate time units, Velocity units, Pressure units and Temperature units. Click **Apply** to write the parameters to the meter.
3. Click the **Setup Outputs** tab to configure the Device Variables Mapping, Units, Frequency/Digital outputs, Frequency and Digital Outputs 1 and 2, Analog outputs, Digital Input, Pressure and Temperature.
 - a. Analog output 1 (HART) - **Content (Primary Variable)** displays Uncorrected Flow Rate and is a read only attribute). Configure **Direction** (flow), **Lower Range value**, **Upper range value** and **Alarm Action** and view the **HART Parameters** Tag, Date, Descriptor, Message, Final Assembly Number Poll Address, Number of Response Preambles.
 - b. Analog Output 2 - **Content (Secondary Variable)** displays Uncorrected Flow Rate and has a read only attribute. Configure **Direction** (flow), **Lower Range value**, **Upper range value** and **Alarm Action**. Map the Third and Four variables using the Manual Setup wizard. Selections include Uncorrected Volume Flow Rate, Pressure and Temperature.

4. After all of the data shown below is entered, click **Apply** to write the parameters to the meter.
 - a. Click the **Frequency/Digital Outputs** tab to configure Frequency/Digital Output 1, 2 and 3 Source and drive Mode. Select the Source for each Frequency/Digital output and select the desired drive Mode. The Mode options are Open Collector which requires an external excitation voltage and pull-up resistor or TTL mode which outputs a 0-5 VDC signal (each Frequency output has an A and B output phase). (**Refresh Note:** If changes are made to any Source variable on this page, apply the changes and navigate to the Guided Setup page. Navigate back to the Manual Setup for the changes to be reflected in other Manual Setup pages).
 - b. Click the **Frequency and Digital Output 1** tab to configure the Content, (flow) Direction, Channel B Phase frequency output, Lag forward, Lead Reverse or Lead Forward, Lag Reverse (Phase B lags Phase A while reporting forward flow and lead Phase A while reporting reverse flow or the opposite), Digital Output 1 Channel A Content and Polarity, Channel B Content and Polarity, Maximum Frequency, and Lower and Upper Range Units of Measure.
 - c. Click the **Frequency and Digital Output 2** tab and repeat Step 3b to configure Frequency and Digital Output 2 parameters.
5. Click **Setup HART** to configure the HART parameters (tag, date, descriptor, message text, Final Assembly number, Poll address and number of response preambles are displayed). After all of the data is entered click **Apply** to write the parameters to the meter.
6. On the Overview page, click **Alert Setup** and select the **Flow Analysis** tab and enable Reverse Flow. Click the **OK** button to return to the Overview page.
7. On the Overview page, click the **Service Tools** tab and select the **Variables** tab. The Flow Data, Path Information, Flow Totals, and All Variables data is populated after you are connected to the meter.
 - a. Click the **Flow Data** tab and view the Flow Direction (Forward or Reverse), Average Flow and Average Sound Velocities values.
 - b. Click the **Path Information** tab and view the Chord performance, Gain, SNR (Signal to Noise Ratio) Signal strength (mV), and Noise (mV).
 - c. Click the **Flow Totals** tab to view the volume totals (forward and reverse uncorrected volume).

- d. Click the **All Variables** tab to view a graphical display of the Primary, Secondary, Third and Fourth Variables.

Figure 5-6 AMS Device Manager - Service Tools All Variables status indicators

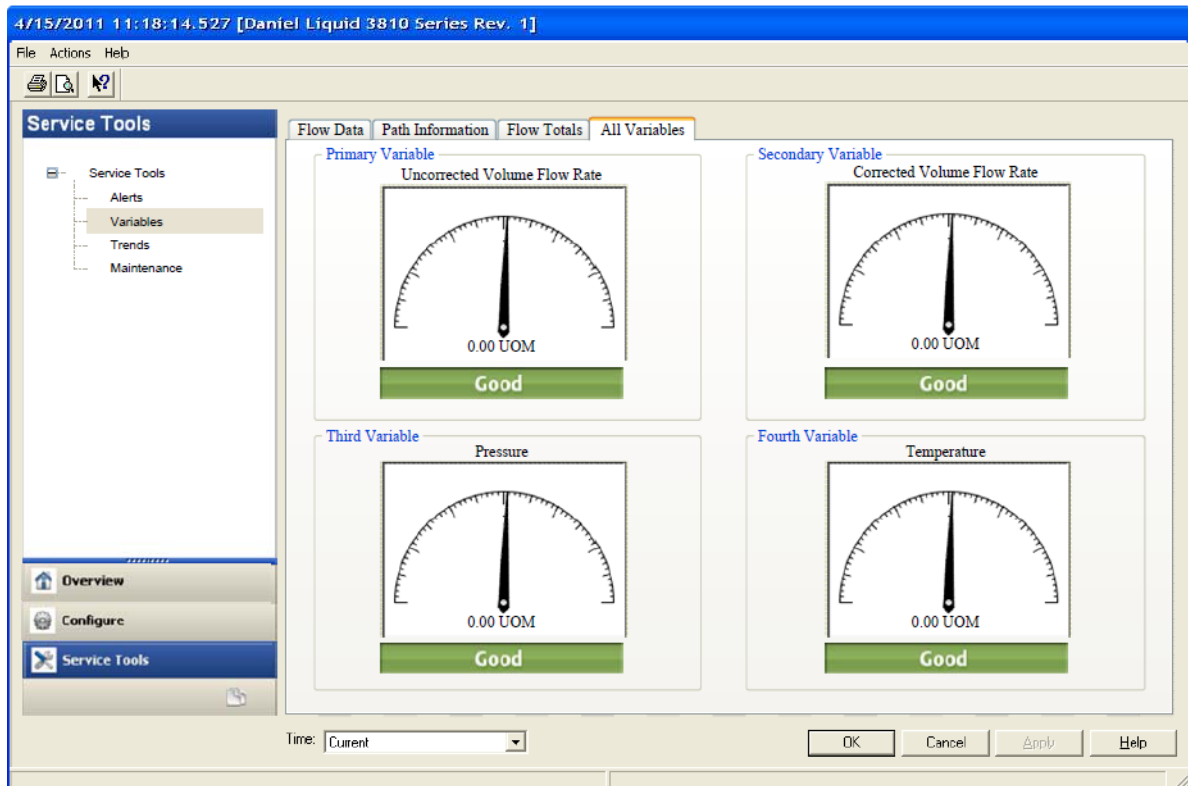

8. Click **OK** to return to the Overview page.
9. Enable the Write Protect switch on the CPU Module to protect the meter's configuration.
10. From the Overview window, click **Display Meter K-Factors**. K-Factors are a read-only values calculated from the Full scale volumetric flow rate used with frequency outputs and the Maximum frequency for frequency output.

Figure 5-7 Display Meter K-Factors

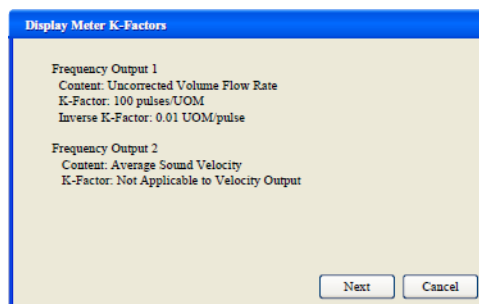

11. Click **Next** to return to the Device Manager Overview page.

AMS Device Manager - Manual Setup

Use the **Manual Setup** wizard to configure the meter's parameters. See [Figure 5-3](#) and [Figure 5-4](#) and from the AMS Device Manager Configure menu click **Manual Setup**.

Figure 5-8 AMS Device Manager - Configure Manual Setup

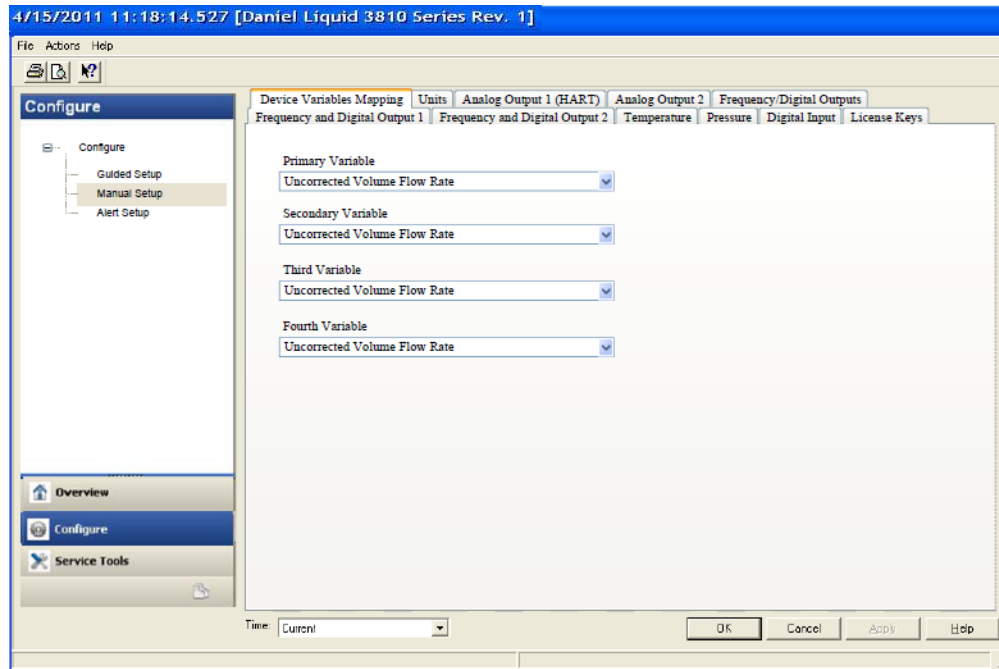

Procedure

1. If installed, remove security wires from the endcap and the Bracket/Cover hex head bolts that secures the Base Enclosure.
1. Disable the Write Protect switch in the CPU Module to write any of the following configuration parameters to your meter.
2. Click the **Device Variables Mapping** tab. The Primary and Secondary variables are read only and are configured for Uncorrected Flow Rate. The Third and Fourth variable configuration choices include Pressure and Temperature.
3. Click the **Units** tab (see [AMS Device Manager - Guided Setup, Step 1](#)).
4. Click the **Analog Output 1 (HART)** tab (see [AMS Device Manager - Guided Setup, Step 2a.](#)).
5. Click the **Analog Output 2** tab. Follow the configuration instructions in the [AMS Device Manager - Guided Setup, Step 2b](#). The read only Secondary variable Content, Uncorrected Flow Rate, displays. Use the drop-down arrow and select the (flow) Direction - Forward or Reverse. Enter a Lower and Upper Range limit. Set the Alarm Action parameters. Click **Apply**, after you enter the data to write the parameters to the meter.

6. Click the **Frequency/Digital** Outputs tab. Follow the configuration instructions in the [AMS Device Manager - Guided Setup, Step 3 a.](#)) (**Refresh Note:** If changes are made to any Source variable on this page, apply the changes and navigate to the Guided Setup page. Navigate back to the Manual Setup for the changes to be reflected in other Manual Setup pages). Click **Apply**, after you enter the data to write the parameters to the meter.
7. Click the **Frequency and Digital Output 1** tab. Follow the configuration instructions in the [AMS Device Manager - Guided Setup, Step 3b.](#) Click **Apply**, after you enter the data to write the parameters to the meter.
8. Click the **Frequency and Digital Output 2** tab. Follow the instructions in the [AMS Device Manager - Guided Setup, Step 3c](#) to configure the Frequency and Digital Output 2 parameters. Click **Apply**, after you enter the data to write the parameters to the meter.
9. Click the **Temperature** tab. Configure the input parameters including: Source (Live Analog or Fixed), Min and Max input limits corresponding to 4 mA and 20 mA respectively and the Low and High alarm limits. Click **Apply**, after you enter the data to write the parameters to the meter.
10. Click the **Pressure** tab. Configure the input parameters including: Source (Live Analog or Fixed), Min and Max input limits corresponding to 4 mA and 20 mA respectively and the Low and High alarm limits. Select either **Gage** or **Absolute** for the type of pressure reading desired. If a live pressure transmitter is connected, select the type of reading the transmitter outputs. If Absolute is selected, you must also enter the Atmospheric pressure. Click **Apply**, after you enter the data to write the parameters to the meter.
11. Click the **Digital Input** tab. The default Digital Input 1 polarity is set to **Normal** for general purpose or set to **Inverted** when used for calibration. Click **Apply**, after you choose the calibration data to write the parameters to the meter.
 - a. Calibration Polarity configuration parameter selections are:
 - Digital Input 1 Calibrate Active High
 - Digital Input 1 Calibrate Active Low

- b. Calibration Gating configuration parameter selections are:
 - Edge gated, active high

Figure 5-9 Gating configuration parameter Edge gated, active high

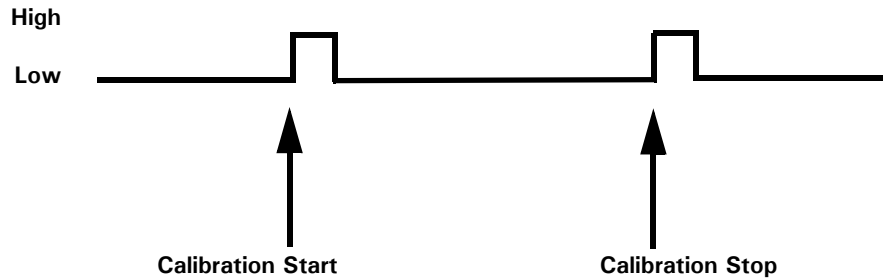

- Edge gated, active low

Figure 5-10 Gating configuration parameter Edge gated, active low

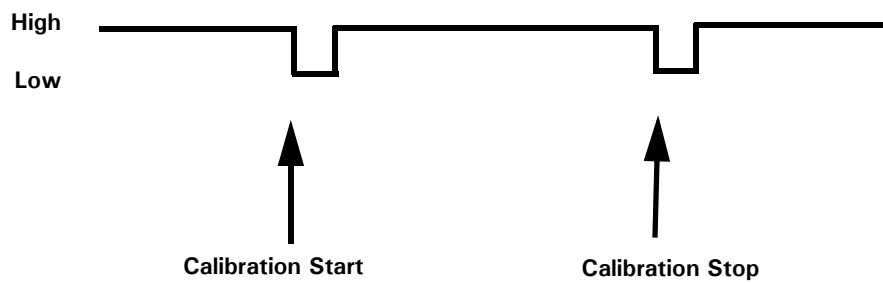

- State gated, active high

Figure 5-11 Gating configuration parameter State gated, active high

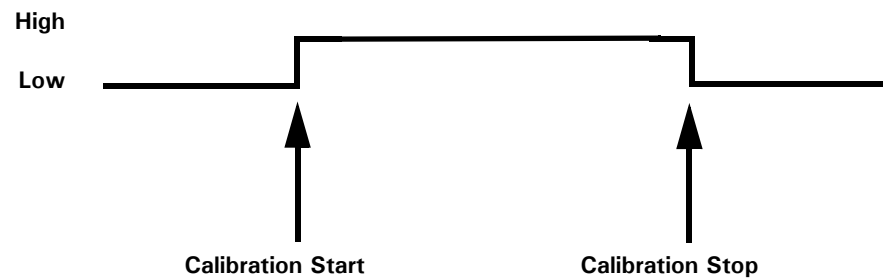

— State gated, active low

Figure 5-12 Gating configuration parameter State gated, active low

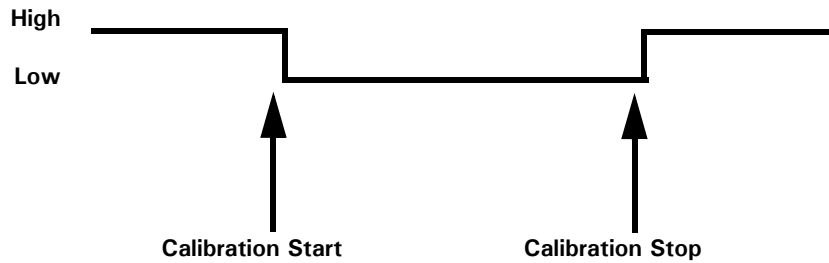

12. Click the **Alert Setup** tab (from the main Configuration page).

Figure 5-13 Configure Flow Analysis Alert

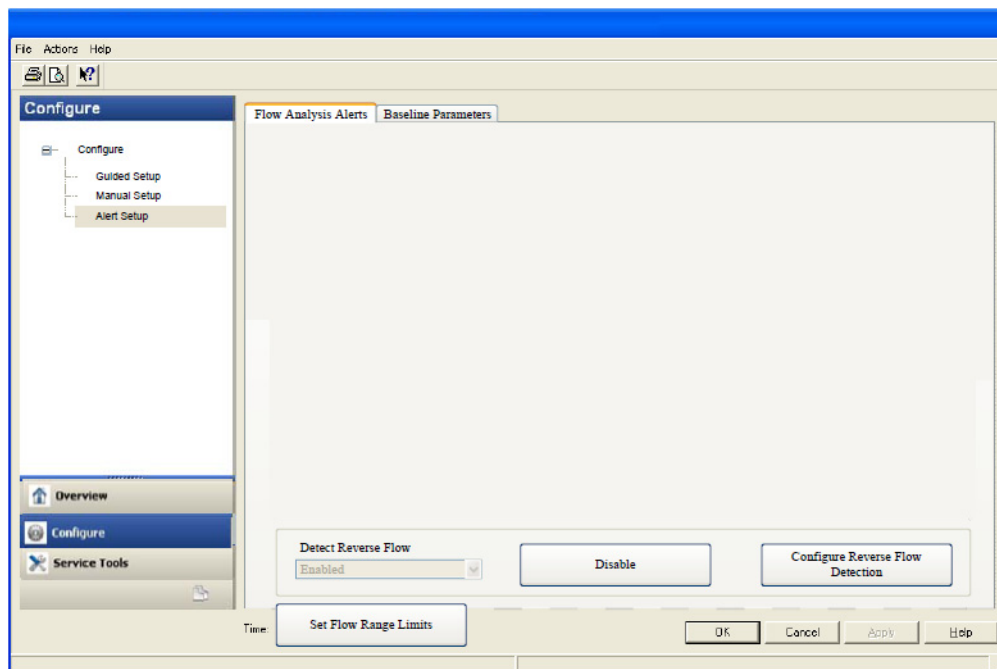

13. Click the **Flow Analysis** tab to select Configure Reverse Flow Detection, if desired. The default setting is **Disabled**. Click the **Disabled** button to send the feature command to the meter. Check for a response error. If no error response is received, click the **Enable** button.
 - a. Enter the minimum reverse flow velocity above which to accumulate flow in the reverse direction for this alert. Enter a positive value for the Reverse Flow Zero Cutoff. Click the **Next** button to write the values to the meter. Check for an error response. If no error response is received, click the **Next** button. The Detect Reverse Flow enabled page displays. Click the **Next** button to display Detect Reverse Flow disabled.
 - b. If an error message is returned, click the **Next** button to display the Method Complete page.
 - c. Click the **Set Flow Range Limits** button and enter a positive value for the Flow Analysis Lower Velocity Range and the Upper Velocity Range Limits. When the velocity is outside of the limit parameters, an alert is triggered. Click the **Next** button to display the Method Complete page.

14. Click the **Service Tools** tab to access the device alerts, variables, trends and maintenance statuses or to edit the configuration parameters.
 - a. Click the **Service Tools | Alerts** tab. If an alert condition exists, the alert type and description displays. Recommended actions are listed to assist you in a resolution. After you resolve the alert condition, click the **Acknowledge** button to clear the alert. Click **Apply** to write the changes to the meter. If no alert condition is active, click **OK** to close the device window.

Figure 5-14 AMS Device Manager - Service Tools Alerts

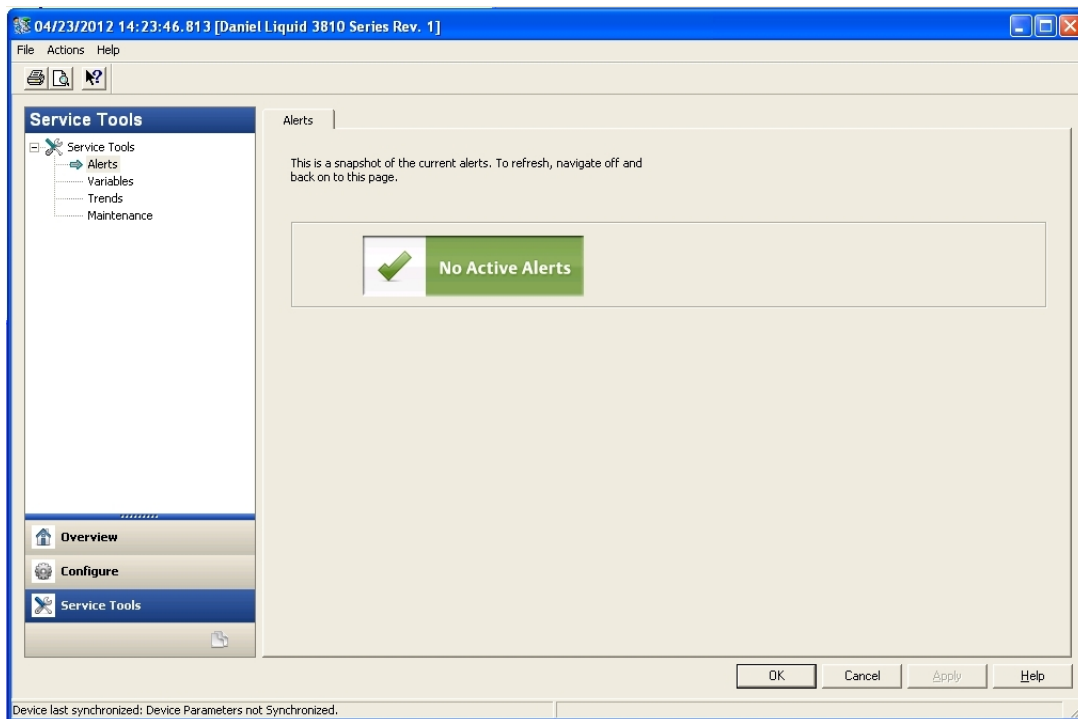

- b. If you change the device configuration, a confirmation dialog displays and prompts you to write the changes to the meter. Click **Yes** to write the changes to the meter or click **No** to cancel pending changes.

Figure 5-15 Configuration changes dialog

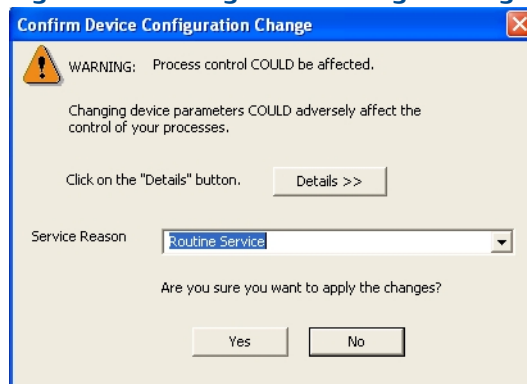

- c. Click the **Service Tools|Variables** tab. The Variables page displays tabs for the device's Flow Data, Path Information, Flow Totals, and All Variables).

Figure 5-16 AMS Device Manager - Service Tools

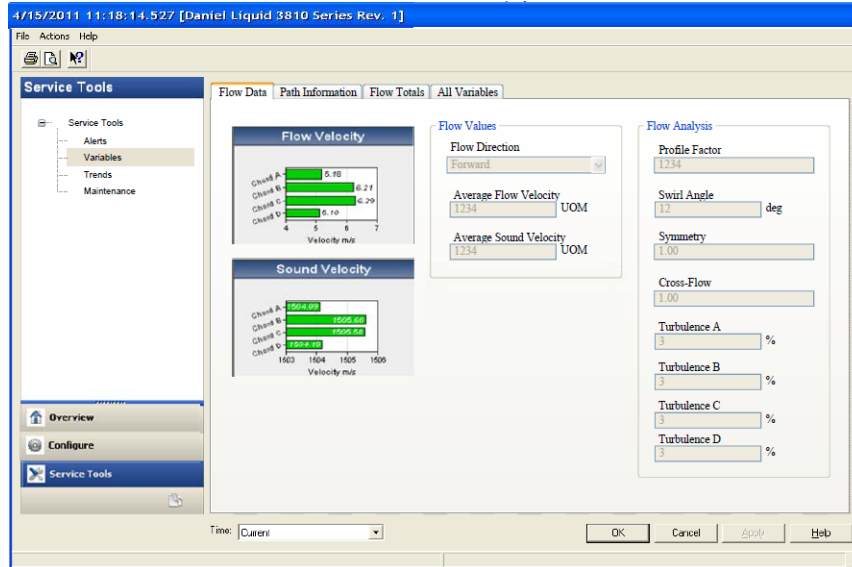

- d. The **Service Tools|Flow Data** page includes charts for flow and sound velocities. The flow values (flow direction, average flow velocity and average sound velocity) parameters are displayed for the connected device.
- e. Click **Service Tools|Variables|Path Information** tab to view the device's chord performance (%), Gain (dB), SNR (dB), Signal (mV) and Noise (mV).
- f. Click **Service Tools|Variables|Flow Totals** to view the volume totals (Forward and reverse Uncorrected Volume) parameters for the connected device.

- g. Click **Service Tools | Variables | All Variables** tab to view Primary, Secondary, Third and Fourth Variable parameter status.

Figure 5-17 AMS Device Manager - Service Tools All Variables

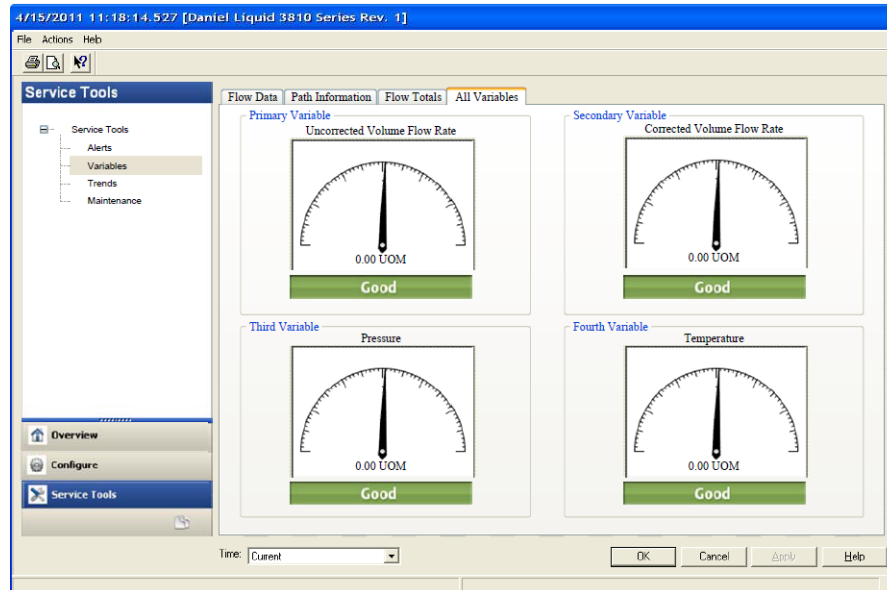

Gauges display each variable's status as good or bad. If a status is bad refer to the Service Tools Alerts page for recommended actions to resolve the alert condition. Also refer to the Field Device Specification manual (00825-0300-3810) for Commands 48 and 140 details.

IMPORTANT

Alerts are triggered for Command 48 Additional device status and Command 140 detailed status information. Alerts are grouped as Failed - Fix Now, Maintenance - Fix Soon and Advisory according to the severity level; 1-6. Severity 1 is the highest and 6 is the lowest level.

- h. Click the **Service Tools | Trends** tab to display the device variables (uncorrected volume flow rate, pressure and temperature) trends.

Figure 5-18 AMS Device Manager - Service Tools Trends

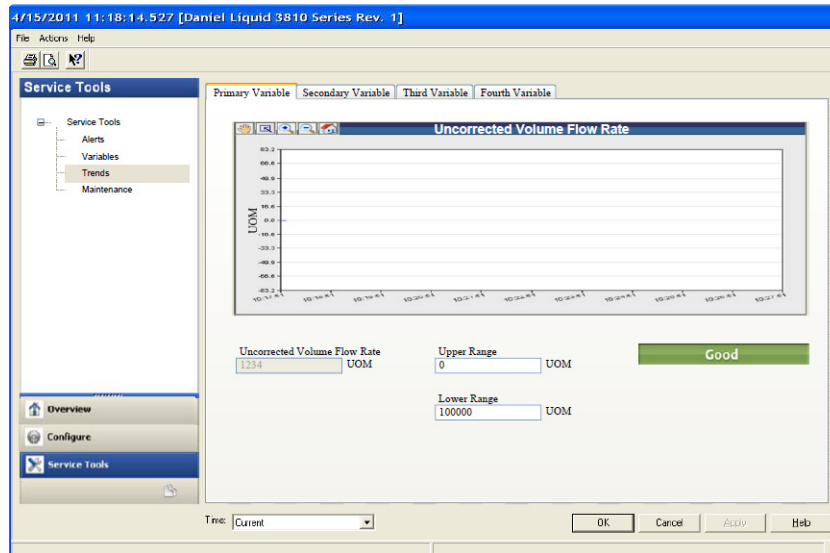

Primary and Secondary variables display real-time uncorrected volume flow rate trends. The third and fourth variables charts displays trends for temperature and pressure.

15. Click the **Service Tools | Routine Maintenance** tab. Click **Analog Output 1 Trim** to perform a digital to analog trim adjustment of the first milliampere output. The 4mA and 20mA output current values should equal the plant's standard values. Click **Yes** to confirm the configuration changes. Repeat this step to trim Analog Output 2 current. Click **Apply** to write the output trim values to the meter. Click **OK** to navigate back to the Service Tools page.
16. Click the **Service Tools | Zero Calibration** tab. See [AMS Device Manager - Guided Setup Step 6](#) to configure the zero flow parameters.
17. After you have changed and written the configuration changes to the meter do the following:
 - a. Enable the Write Protect switch on the CPU Module to protect the meter's configuration.
 - b. Replace the end cap and if required, apply security seals through the endcap holes and through the hex head bolts that secure the Bracket/Cover to the Base enclosure.

Note: The next time you connect to the device using MeterLink, the Monitor page displays a Meter status alarm that the configuration has changed and remains latched until acknowledged. Click **Ack** (acknowledge) to clear the alarm.

5.4 Use a Field Communicator to configure the meter

important

Follow all guidelines and precautions described in the Field Communicator User Manual and in the Rosemount™ Liquid Ultrasonic Flow Meter documentation when working in a hazardous area.

Installation Requirements

- Emerson Field Communicator software, license, installation guide and user manual available on the Emerson Asset Optimization Field Communicator website:

<http://www2.emersonprocess.com/en-US/brands/Field-Communicator/Pages/Documentation.aspx>

- Rosemount HART Device Description (HART DD) installed for the meter
- Network configured for a Field Communicator
- Rosemount Field Device Specification Manual (00825-0400-3240) available on the Emerson website

<http://www2.emersonprocess.com/en-US/brands/emerson/Flow/ultrasonics/Pages/Ultra-sonic.aspx>

- System wiring diagram drawing number DMC - 004936 (see Appendix A)
- Power supply

Procedure

1. Remove electrical power to the meter. If installed, remove the endcap security latches and seals and then, remove the endcap.
2. Refer to the Field Communicator Users Manual wiring diagrams and commissioning instructions provided with your handheld device. Register the product to activate the end user license.
3. Fully charge the Field Communicator battery prior to use. **Important: Do not change the battery in a hazardous area environment. The power supply is not intrinsically safe.**
4. On the meter, run the wires through the field wiring conduit and into the transmitter electronics enclosure.

Figure 5-19 Transmitter field wiring conduit entries

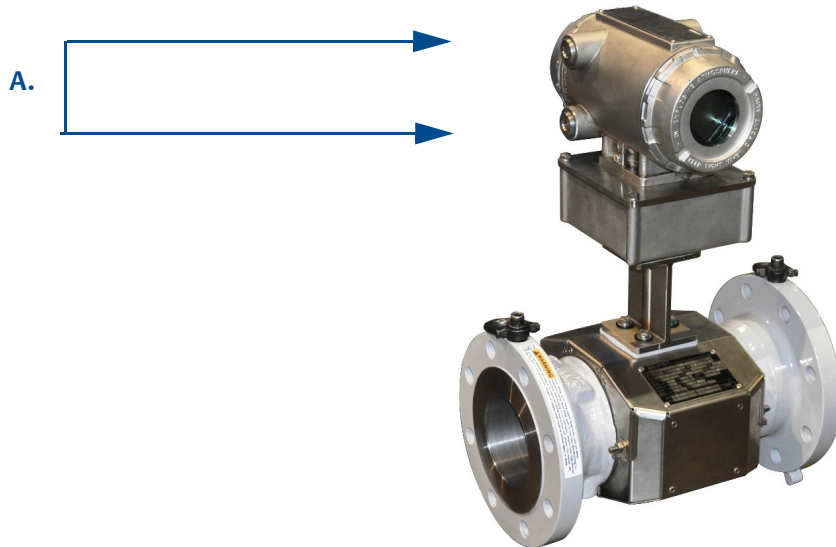

A. Field wiring conduit entries (4)

5. Wire Analog Input 1 (AI1) and Analog Output 1 (AO1) as shown in Figure 5-20 and Appendix A, drawing DMC-004936.

Figure 5-20 Field Communicator wiring diagram for the 3810 Series electronics

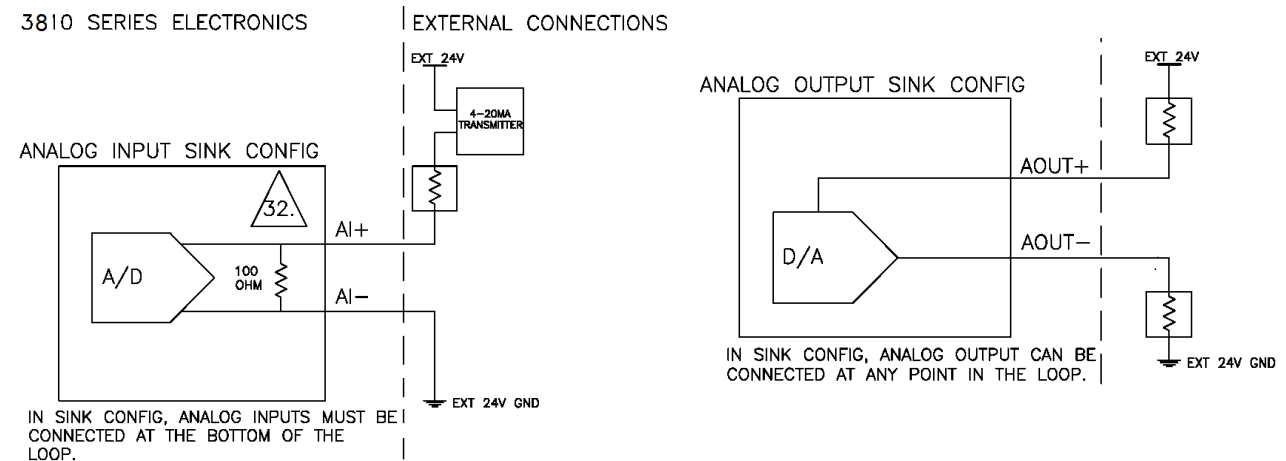

6. Use the leads provided with the Field Communicator to connect to your device.
7. Press and hold the **Power** button on the Field Communicator until the green light blinks.
8. Use the touch screen on the Field Communicator, the keypad or use the stylus to navigate through the device menus.
9. Refer to the Menu tree in Section D.1.1 of the Rosemount HART Field Device Specification manual (00825-0400-3240) for the device fast key sequences. Included in the menu tree are:
 - Diagram Page 1 - 3810 Series Root Menu; **Overview, Configure | Manual Setup**
 - Diagram Page 2 - **Configure | Manual Setup** (continued) and **Alerts Setup**
 - Diagram Page 3 - **Service Tools | Alerts and Variables**
 - Diagram Page 4 - **Service Tools | Variables** (continued), **Service Tools | Trends, and Service Tools | Maintenance**

If you encounter problems, refer to the contact information on the back cover of this manual or the contacts included in the Field Communicator Users Manual.

5.5 Security seals for the meter

For the integrity of the meter metrology and to prevent tampering with the transmitter electronics and transducer assemblies install security wire seals on the Transmitter Electronics Enclosure end caps, the Base Enclosure hex head bolts, the shroud latches ([see Section 3.7](#)).

Apply the conduit ports sealing compound according to the customer's requirements to seal the meter ([see Section 3.4.1](#) and [see Section 3.4.2](#)).

Appendix A: Engineering drawings

A.1 Rosemount 3810 Series Liquid Ultrasonic Flow Meter drawings

This appendix contains the following engineering drawing(s) for the ultrasonic meter:

DMC-004936 Rosemount 3810 Series Ultrasonic Flow Meter System Wiring Diagram

EXPLOSION PROOF
TRANSMITTER
ENCLOSURE
ASSEMBLY

HAZARDOUS LOCATION CLASS I, GROUP C OR D
HAZARDOUS LOCATION Ex d ia IIB T4

NON-HAZARDOUS LOCATION

3810 SERIES ELECTRONICS

EXPLOSION-PROOF SEAL (FIELD PROVIDED) EXPLOSION-PROOF WIRING (PER LOCAL CODE)

RJ45 CONNECTIONS

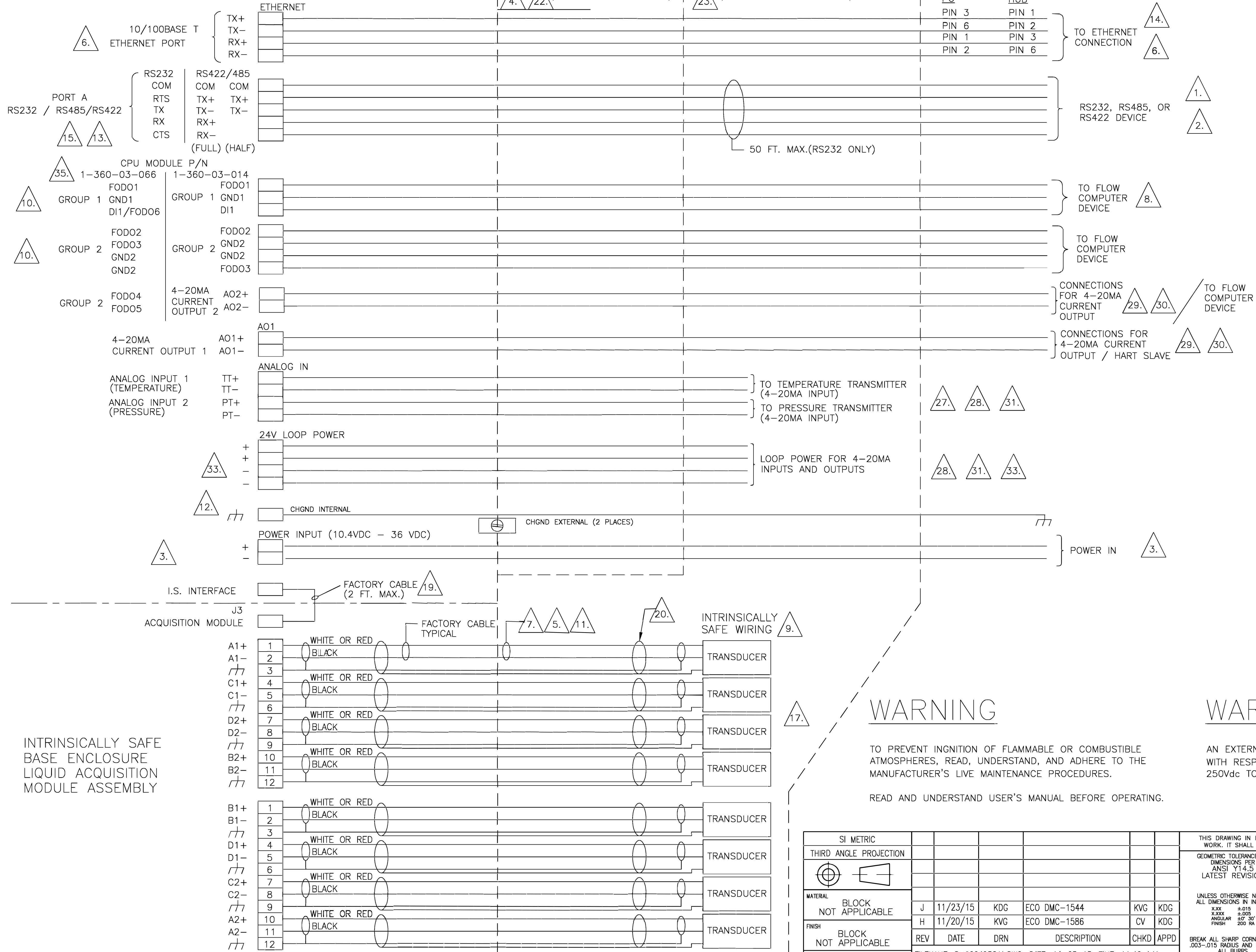

WARNING

TO PREVENT IGNITION OF FLAMMABLE OR COMBUSTIBLE ATMOSPHERES, READ, UNDERSTAND, AND ADHERE TO THE MANUFACTURER'S LIVE MAINTENANCE PROCEDURES.

READ AND UNDERSTAND USER'S MANUAL BEFORE OPERATING.

WARNING

AN EXTERNAL POWER SOURCE SHALL NOT APPLY A POTENTIAL WITH RESPECT TO EARTH (Um) IN EXCESS OF 250 Vrms OR 250Vdc TO ANY TERMINAL CONNECTION IN THIS UNIT.

SI METRIC						
THIRD ANGLE PROJECTION						
MATERIAL	BLOCK NOT APPLICABLE	J	11/23/15	KDG	ECO DMC-1544	KVG KDG
FINISH	BLOCK NOT APPLICABLE	H	11/20/15	KVG	ECO DMC-1586	CV KDG
REV	DATE	DRN	DESCRIPTION	CHKD	APPD	
PROJ. FILE NO.	USM-01307	FILENAME:	DMC004936J1.DWG, DATE:	11-23-15, TIME:	11:40 A.M.	

THIS DRAWING IN DESIGN AND DETAIL IS OUR PROPERTY AND MUST NOT BE USED EXCEPT IN CONNECTION WITH OUR WORK. IT SHALL NOT BE REPRODUCED AND SHALL BE RETURNED TO US ON DEMAND. ALL RIGHTS ARE RESERVED.			
GEOMETRIC TOLERANCES & DIMENSIONS PER ANSI Y14.5 LATEST REVISION			
UNLESS OTHERWISE NOTED ALL DIMENSIONS IN INCHES X.XX ±.015 X.XXX ±.005 ANGULAR 30° 30' FINISH 200 RA MAX			
TITLE 3810 SERIES ULTRASONIC METER SYSTEM WIRING DIAGRAM			
DRN	KDG	DATE	09/29/10
CHKD	KVG	DATE	09/29/10
APPD	KDG	DATE	09/29/10
DWG NO.	DMC-004936		
SCALE	NA	P/N	
SHT 1 OF 4			REV J

EXPLOSION PROOF
TRANSMITTER
ENCLOSURE
ASSEMBLY

HAZARDOUS LOCATION CLASS I, GROUP C OR D
HAZARDOUS LOCATION Ex d ia IIB T4

NON-HAZARDOUS LOCATION

3810 SERIES ELECTRONICS
(OPTIONAL I/O MODULES)

EXPLOSION-PROOF SEAL (FIELD PROVIDED) EXPLOSION-PROOF WIRING (PER LOCAL CODE)

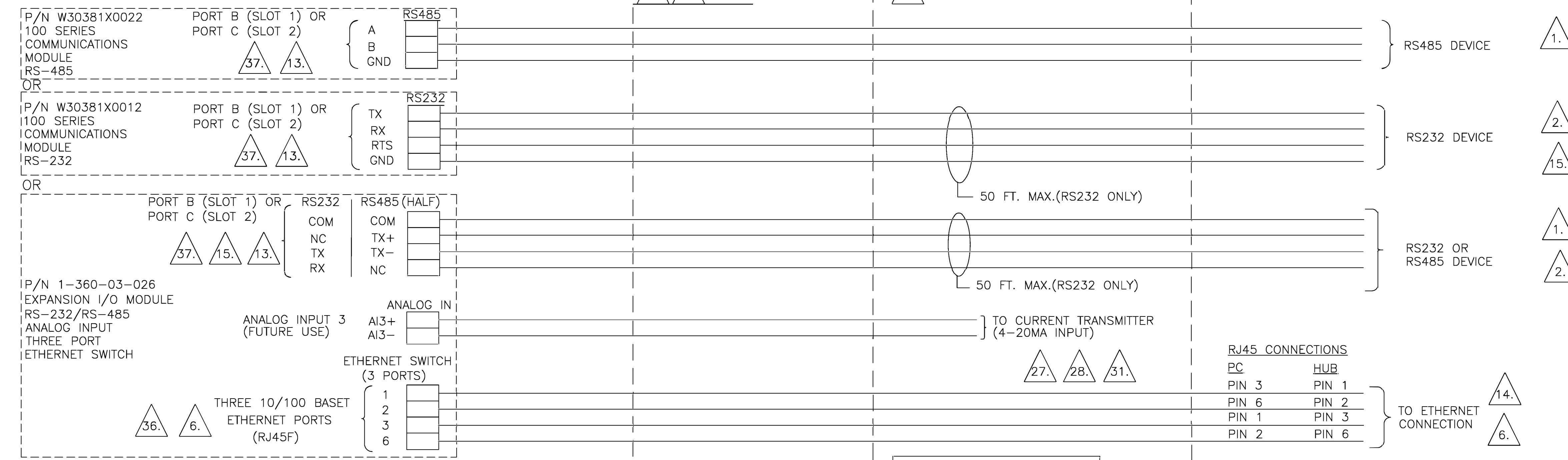

INTRINSICALLY SAFE
BASE ENCLOSURE
LIQUID ACQUISITION
MODULE ASSEMBLY

J6
(SEE NOTES BELOW)

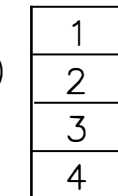

INTRINSICALLY
SAFE WIRING

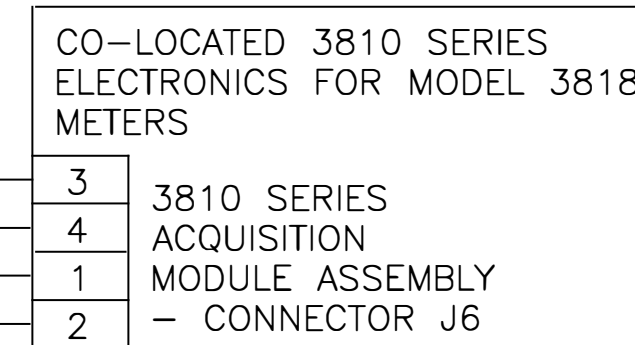

1. Terminal J6 is intended to provide power to the device it is connected to and may also receive power. The entity parameters assigned for terminal J6 are as follows:

Output parameters:	Input parameters:
Vt (or Uo) = 6.51 VDC	Vmax (or Ui) = 6.51 VDC
It (or Io) = 65.8 mA	Imax (or Ii) = 65.8 mA
Po = 107 mW	Pmax (or Pi) = 107 mW
Ca (or Co) = 500 uF	Ci = 0 uF
La (or Lo) = 32.8 mH	Li = 0 mH

2. Selected intrinsically safe equipment must be third party listed as intrinsically safe for the application, and have intrinsically safe entity parameters conforming to Table 1.

I.S. Equipment	Terminal J6
Vmax (or Ui) ≥	Voc or Vt (or Uo)
Imax (or Ii) ≥	Isc or It (or Io)
Pmax, Pi ≥	Po
Ci + Ccable ≤	Ca (or Co)
Li + Lcable ≤	La (or Lo)

3. Intrinsically safe apparatus connected to terminal J6 that may provide power, must have intrinsically safe entity parameters conforming to Table 2.

Terminal J6	Intrinsically safe apparatus with output parameters
Vmax (or Ui) ≥	Voc or Vt (or Uo)
Imax (or Ii) ≥	Isc or It (or Io)
Pmax, Pi ≥	Po
Ci + Ccable ≤	Ca (or Co)
Li + Lcable ≤	La (or Lo)

4. Capacitance and inductance of the field wiring from the intrinsically safe equipment to the terminal J6 shall be calculated and must be included in the system calculations as shown in Table 1 and Table 2. Cable capacitance, Ccable, plus intrinsically safe equipment capacitance, Ci must be less than the marked capacitance, Ca (or Co), shown on any associated apparatus used. The same applies for inductance (Lcable, Li and La or Lo, respectively). Where the cable capacitance and inductance per foot are not known, the following values shall be used: Ccable = 60 pF/ft., Lcable = 0.2 μH/ft.

5. For installations in which both the Ci and Li of the intrinsically safe apparatus connected to terminal J6 exceeds 1% of the stated Co and Lo parameters (excluding the cable), then 50% of Co and Lo parameters are applicable and shall not be exceeded.

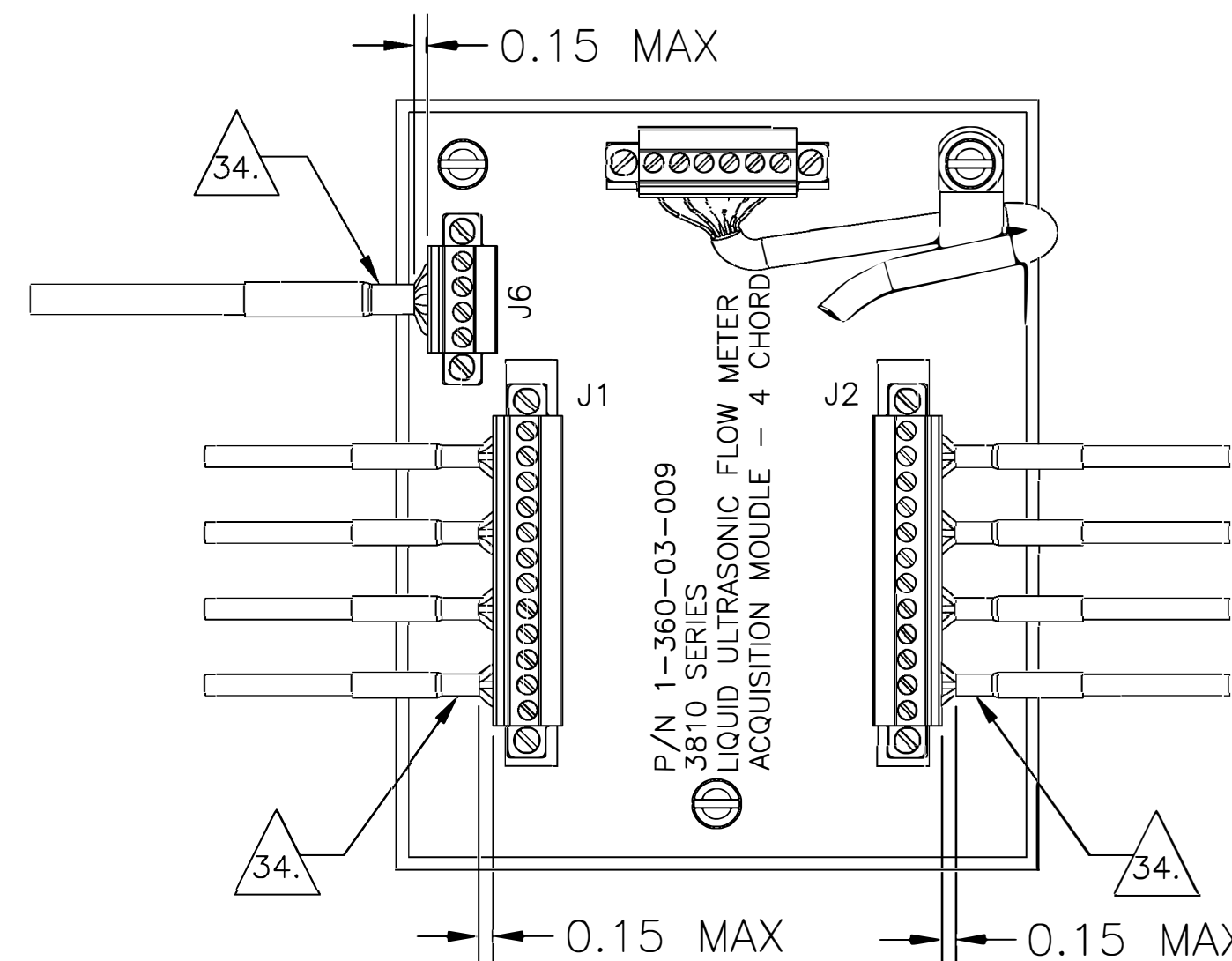

SI METRIC		THIRD ANGLE PROJECTION	
MATERIAL	BLOCK NOT APPLICABLE	REV	DATE
FINISH	BLOCK NOT APPLICABLE	DRN	DESCRIPTION
PROJ. FILE NO. USM-01307	FILENAME: DMC004936J2.DWG, DATE: 11-23-15, TIME: 11:40 A.M.	CHKD	APPD

THIS DRAWING IN DESIGN AND DETAIL IS OUR PROPERTY AND MUST NOT BE USED EXCEPT IN CONNECTION WITH OUR WORK. IT SHALL NOT BE REPRODUCED AND SHALL BE RETURNED TO US ON DEMAND. ALL RIGHTS ARE RESERVED.			
GEOMETRIC TOLERANCES & DIMENSIONS PER ANSI Y14.5 LATEST REVISION			
UNLESS OTHERWISE NOTED ALL DIMENSIONS IN INCHES			
TITLE 3810 SERIES ULTRASONIC METER SYSTEM WIRING DIAGRAM			
DRN	KGC	DATE 09/29/10	DWG NO. DMC-004936
CHKD	KGC	DATE 09/29/10	REV J
APPD	KGC	DATE 09/29/10	SCALE NA P/N
			SHT 2 OF 4

NOTES:

1. MAX LENGTH OF RS-485 WIRING IS 2,000 FT.
 2. ETHERNET OR RS-422 IS THE PREFERRED COMMUNICATIONS INTERFACE. OPTIONALLY, RS-232 MAY BE USED FOR SHORT DISTANCES, (50 FT.)
 3. POWER INPUT IS NOMINAL 24 VDC. INPUT RANGE 10.4-36V DC. POLARITY INSENSITIVE
 4. AN EXPLOSION-PROOF SEAL IS REQUIRED WITHIN 457 MM(18 INCHES) OF THE ENCLOSURE.
 5. MODEL 3814 AND 3818:
TRANSDUCER CABLE IS 20 AWG. SHIELDED PAIR, 20 AWG DRAIN, BRAIDED SHIELD, REMKE INDUSTRIES OR EQUIVALENT, 15 FT. MAX.
MODEL 3812:
TRANSDUCER CABLE IS 26 AWG. SHIELDED PAIR, 15 FT. MAX.
 6. FOR OPTIMUM DIAGNOSTIC INTERFACE, WIRING ETHERNET PORT IS RECOMMENDED. USE CAT5 ETHERNET CABLE
 7. INTRINSICALLY SAFE WIRING SHALL BE INSTALLED IN ACCORDANCE WITH THE ARTICLE 504 OF THE NATIONAL ELECTRICAL CODE OR RULE 18-066 OF THE CANADIAN ELECTRICAL CODE.
 8. DIGITAL INPUT 1 (DI1) IS CONTACT CLOSURE ONLY.
 9. TRANSDUCER PAIRS REQUIRED
- | MODEL NO. | TRANSDUCER PAIRS REQUIRED | TYPICAL CHORDS USED |
|-----------|---------------------------|---------------------|
| 3814 | 4 | A,B,C,D |
| 3812 | 2 | A,B |
| 3818 | 8 | 2 x MODEL 3814 |
10. FODO OUTPUTS 1 THROUGH 6 CAN BE INDEPENDENTLY CONFIGURED TO FUNCTION AS FREQUENCY OUTPUTS OR DIGITAL STATUS OUTPUTS. THEY CAN EACH BE INDEPENDENTLY CONFIGURED TO DRIVE AS TTL OR OPEN COLLECTOR. FODO6 SHARES CONNECTIONS WITH DI1 ON CPU MODULE P/N 1-360-03-066. DI1/FODO6 FUNCTION IS SOFTWARE CONFIGURABLE. GROUP 1 OUTPUTS (GND1) ARE ELECTRICALLY ISOLATED FROM GROUP 2 OUTPUTS (GND2)
 11. EXPLOSION PROOF TRANSMITTER ENCLOSURE AND INTRINSICALLY SAFE BASE ENCLOSURE MUST BE MOUNTED IN A REMOTE LOCATION OFF THE METER BODY IF THE PROCESS TEMPERATURE EXCEEDS THE LOWER OR UPPER AMBIENT RATING -40 °C TO 60 °C (-40 °F TO 140 °F). THE ELECTRONICS MUST BE MOUNTED NEXT TO THE METER BODY ON A PIPE STAND OR OTHER RIGID STRUCTURE.
- MODEL 3812:
FOR THE MODEL 3812, THE TOTAL CABLE LENGTH SHALL NOT EXCEED 4.7 METERS (15 FEET) BETWEEN THE ACQUISITION MODULE AND ANY TRANSDUCER. THE REMOTE MOUNT OPTION IS LIMITED TO THE PROCESS TEMPERATURE RANGE OF THE APPROPRIATE TRANSDUCER TYPE (SEE NOTE 17).
- MODEL 3814:
TRANSDUCER CABLES (P/N 1-360-01-601, 15 FT. LONG) SHALL BE USED TO CONNECT THE 3810 SERIES ELECTRONICS TO EACH OF THE TRANSDUCERS INSTALLED IN A MODEL 3814 METER BODY FOR PROCESS FLUID TEMPERATURES UP TO 100 °C (212 °F). FOR PROCESS FLUID TEMPERATURES UP TO 150 °C (302 °F), THE HIGH TEMPERATURE TRANSDUCER CABLES (P/N 1-360-01-800, 15 FT. LONG OR 1-360-01-801, 15 FT. LONG) SHALL BE USED TO CONNECT THE 3810 SERIES ELECTRONICS TO EACH OF THE TRANSDUCERS INSTALLED IN A MODEL 3814 METER BODY. IN ANY CONFIGURATION, THE TOTAL CABLE LENGTH SHALL NOT EXCEED 4.7 METERS (15 FEET) BETWEEN THE ACQUISITION MODULE AND ANY TRANSDUCER.
- MODEL 3818:
FOR THE MODEL 3818, THE TOTAL CABLE LENGTH SHALL NOT EXCEED 4.7 METERS (15 FEET) BETWEEN THE ACQUISITION MODULE AND ANY TRANSDUCER. THE REMOTE MOUNT OPTION IS LIMITED TO THE PROCESS TEMPERATURE RANGE OF THE APPROPRIATE TRANSDUCER TYPE (SEE NOTE 17).
12. THE INTERNAL GROUNDING TERMINAL SHALL BE USED AS THE PRIMARY EQUIPMENT GROUND. THE EXTERNAL GROUND TERMINAL IS ONLY A SUPPLEMENTAL BONDING CONNECTION WHERE LOCAL AUTHORITIES PERMIT OR REQUIRE SUCH A CONNECTION.
 13. TO METER. (I.E. PC - TX -> METER - RX)
COMM SIGNAL NAMING CONVENTION IS WITH RESPECT

14. RJ45 SOCKET NUMBERING AND T568B WIRING FOR STANDARD PATCH CABLING. ETHERNET PORTS AUTOMATICALLY DETECT DIRECT PC OR HUB CONNECTION. CROSSOVER NOT REQUIRED FOR DIRECT PC CONNECTION

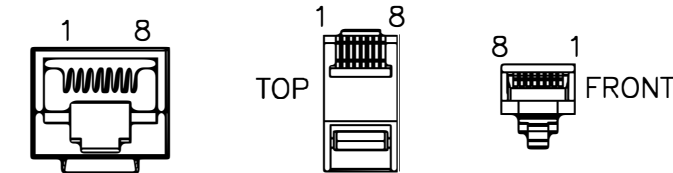

CPU MODULE	RJ45 (MALE)	EXPANSION MODULE	RJ45 (FEMALE)	RJ45 (MALE)
TX+	--> PIN 1 (O/W)	PIN 1	-->	PIN 1 (O/W)
TX-	--> PIN 2 (O)	PIN 2	-->	PIN 2 (O)
RX+	--> PIN 3 (G/W)	PIN 3	-->	PIN 3 (G/W)
RX-	--> PIN 6 (G)	PIN 6	-->	PIN 6 (G)

15. PC SIDE SERIAL CONNECTION MUST BE WIRED FOR COMPLETE NULL MODEM FOR SUCCESSFUL HOOKUP TO METER
NULL MODEM CONNECTIONS FOR PC END OF CABLE (RS232 WITH NO HANDSHAKING ONLY)

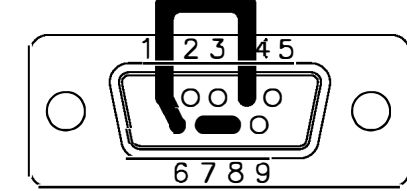

CPU MODULE	DB9 (FEMALE)
RX	--> PIN 3
TX	--> PIN 2
COM	--> PIN 5

CPU MODULE DIP SWITCH SETTINGS

SWITCH	DESCRIPTION
PORT A	PORT A OVERRIDE
DHCP	DHCP SERVER ENABLE
WRITE PROT.	MEMORY PROTECT

TO ENABLE THE PORT A OVERRIDE, SWITCH MUST BE MOVED FROM THE OFF TO ON POSITION. PORT A WILL BE SET TO 19200,8,N,1 ID 32 FOR TWO MINUTES.

17. MODEL 3810 SERIES TRANSDUCERS TYPE LT-01, LT-03, LT-04, LT-05, LT-06, LT-07, LT-08, LT-09, LT-10, LT-11, LT-12, LT-13, LT-14, LT-15, LT-16 AND LT-17.

THE TRANSDUCERS ARE NOT INTENDED FOR USE ACROSS A BOUNDARY WALL.

THE TEMPERATURE CLASSIFICATION OF THE TRANSDUCERS IS T4 UNLESS THE ELECTRONICS ENCLOSURE IS REMOTELY MOUNTED FROM THE METER BODY. IF THE ELECTRONICS ENCLOSURE IS NOT MOUNTED TO THE METER BODY, REFER TO THE CERTIFICATION LABEL DMC-006037 ON THE METER BODY FOR THE APPROPRIATE CLASSIFICATION OF THE TRANSDUCERS, T4 OR T3.

PROCESS TEMPERATURE MUST NOT EXCEED THE OPERATING TEMPERATURE RANGE OF THE TRANSDUCERS AS INDICATED IN THE TABLE BELOW.

TRANSDUCER TYPE	PROCESS TEMPERATURE RANGE
LT-01	-50 °C (-58 °F) TO +100 °C (+212 °F)
LT-03	-50 °C (-58 °F) TO +100 °C (+212 °F)
LT-04	-50 °C (-58 °F) TO +150 °C (+302 °F)
LT-05	-50 °C (-58 °F) TO +150 °C (+302 °F)
LT-06	-196 °C (-321 °F) TO +60 °C (+140 °F)
LT-07	-196 °C (-321 °F) TO +60 °C (+140 °F)
LT-07B	-196 °C (-321 °F) TO +60 °C (+140 °F)
LT-08	-50 °C (-58 °F) TO +150 °C (+302 °F)
LT-09	-50 °C (-58 °F) TO +150 °C (+302 °F)
LT-10	-50 °C (-58 °F) TO +150 °C (+302 °F)
LT-11	-50 °C (-58 °F) TO +150 °C (+302 °F)
LT-12	-50 °C (-58 °F) TO +150 °C (+302 °F)
LT-13	-50 °C (-58 °F) TO +150 °C (+302 °F)
LT-14	-50 °C (-58 °F) TO +200 °C (+392 °F)
LT-15	-50 °C (-58 °F) TO +200 °C (+392 °F)
LT-16	-50 °C (-58 °F) TO +200 °C (+392 °F)
LT-17	-50 °C (-58 °F) TO +200 °C (+392 °F)

18. THE 3410 SERIES METER STANDARD ENCLOSURE OPTION HAS ONE AVAILABLE SLOT FOR A SINGLE I/O MODULE. THE RETROFIT ENCLOSURE OPTION HAS TWO AVAILABLE SLOTS FOR TWO I/O MODULES. RETROFIT OPTION SUPPORTS INSTALLATION OF ONLY ONE EXPANSION I/O MODULE WITH ETHERNET SWITCH (P/N 1-360-03-026) IN EITHER SLOT

19. FACTORY CABLE INCLUDES EXPLOSION PROOF SEAL.

20. SECONDARY SHIELD ONLY PRESENT ON MODEL 3814 AND 3818 LNG TRANSDUCER CABLING.

21. DIMENSIONS OF FLAMEPROOF JOINTS ARE OTHER THAN THE RELEVANT MINIMUM OR MAXIMUM SPECIFIED IN TABLE 3 OF EN/IEC 60079-1:2007. PLEASE CONTACT MANUFACTURER FOR DETAILS.

22. ALL CABLE ENTRY DEVICES SHALL BE CERTIFIED IN TYPE OF EXPLOSION PROTECTION FLAMEPROOF ENCLOSURE 'd', SUITABLE FOR THE CONDITIONS OF USE AND CORRECTLY INSTALLED. CONTINUED ->

22. CONT. IECEx UL 11.0004X CERTIFICATE NOTE: TABULATION OF ADDITIONAL PREVIOUS EDITIONS APPLIED

THE FOLLOWING ADDITIONAL PREVIOUS EDITIONS OF STANDARDS NOTED UNDER THE "STANDARDS" SECTION OF THIS CERTIFICATE WERE APPLIED TO INTEGRAL COMPONENTS AS ITEMIZED BELOW. THERE ARE NO SIGNIFICANT SAFETY RELATED CHANGES BETWEEN THESE PREVIOUS EDITIONS AND THE EDITIONS NOTED UNDER THE "STANDARDS" SECTION.

BLANKING ELEMENTS MODEL NUMBER PA-D-3-0-30 OR PA-D-1-1-30 MANUFACTURED BY REDAPT.	IEC 60079-0:2009
THREAD ADAPTERS MODEL NUMBER RD-U-3-0-30-04 OR RD-U-1-1-30-04 MANUFACTURED BY REDAPT.	IEC 60079-0:2009

23. FIELD WIRING MUST BE RATED FOR 75 °C OR HIGHER. FOR AMBIENT TEMPERATURES BELOW -10 °C (14 °F), USE FIELD WIRING SUITABLE FOR THE MINIMUM AMBIENT TEMPERATURE.

24. REFER TO THE APPROPRIATE INSTRUCTION MANUAL FOR INSTRUCTIONS FOR SAFETY INCLUDING PUTTING INTO SERVICE, USE, ASSEMBLING AND DISMANTLING, MAINTENANCE, INSTALLATION, AND ADJUSTMENT.

MODEL 3812:
00825-0100-3812 3812 INSTALLATION MANUAL
00809-0100-3812 3812 MAINTENANCE AND TROUBLESHOOTING MANUAL

MODEL 3814:
00825-0100-3814 3810 SERIES INSTALLATION MANUAL
00809-0100-3814 3814 MAINTENANCE AND TROUBLESHOOTING MANUAL

MODEL 3818:
00825-0100-3818 3818 INSTALLATION MANUAL
00809-0100-3818 3818 MAINTENANCE AND TROUBLESHOOTING

25. LABEL FOR 3810 SERIES FLOW METER:
DATE CODE IS INCLUDED IN THE SERIAL NUMBER. SERIAL NUMBER FORMAT SHALL BE "YY-WWXXXX" WHERE:
YY = 2-DIGIT YEAR OF MANUFACTURE
WW = WEEK OF MANUFACTURE (01-52)
XXXX = SEQUENTIALLY INCREMENTING NUMBER

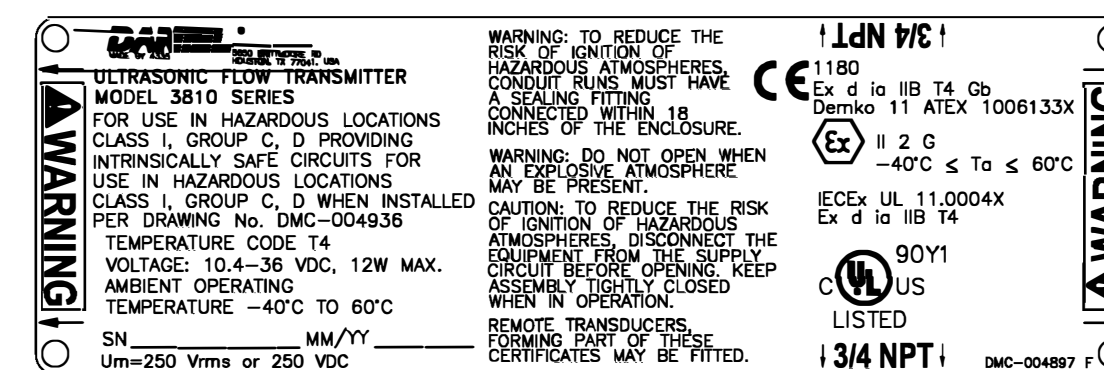

SI METRIC									
THIRD ANGLE PROJECTION								THIS DRAWING IN DESIGN AND DETAIL IS OUR PROPERTY AND MUST NOT BE USED EXCEPT IN CONNECTION WITH OUR WORK. IT SHALL NOT BE REPRODUCED AND SHALL BE RETURNED TO US ON DEMAND. ALL RIGHTS ARE RESERVED.	
MATERIAL	BLOCK NOT APPLICABLE	J	11/23/15	KDG	ECO DMC-1544	KVG	KDG	GEOMETRIC TOLERANCES & DIMENSIONS PER ANSI Y14.5 LATEST REVISION	
FINISH	BLOCK NOT APPLICABLE	H	11/20/15	KVG	ECO DMC-1586	CV	KDG	UNLESS OTHERWISE NOTED ALL DIMENSIONS IN INCHES X.XX ±.015 X.XXX ±.005 ANGULAR ±.5° FINISH 200 RA MAX	
PROJ. FILE NO. USM-01307		REV	DATE	DRN	DESCRIPTION	CHKD	APPD	TITLE 3810 SERIES ULTRASONIC METER SYSTEM WIRING DIAGRAM	
					FILENAME: DMC004936J.DWG, DATE: 11-23-15, TIME: 11:40 A.M.			DRN KDG DATE 09/29/10 DWG NO. DMC-004936 REV J	
								BREAK ALL SHARP CORNERS TO .003-.015 RADIUS AND REMOVE ALL BURRS	
								APPD KDG DATE 09/29/10 SCALE NA P/N SHIT 3 OF 4	

26. FOR THE U.L. U.S. MARK INVESTIGATION, THE DEVICE COMPLIES TO THE FOLLOWING STANDARDS FOR USE IN THE UNITED STATES:

UL 1203, 4TH EDITION
UL 508, 17TH EDITION
UL 913, 7TH EDITION

FOR THE U.L.-C MARK INVESTIGATION, THE DEVICE COMPLIES TO THE FOLLOWING STANDARDS FOR USE IN CANADA:

CAN/CSA C22.2 No. 30-M1986, REV. 1988-11
CAN/CSA C22.2 No. 14-10
CAN/CSA C22.2 No. 157-92

FOR THE ATEX MARK INVESTIGATION, THE DEVICE COMPLIES TO THE FOLLOWING STANDARDS FOR USE IN THE EUROPEAN UNION:

EN 60079-0:2012
EN 60079-1:2007
EN 60079-11:2007

FOR THE IECEx MARK INVESTIGATION, THE DEVICE COMPLIES TO THE FOLLOWING STANDARDS:

IEC 60079-0:2012
IEC 60079-1:2007
IEC 60079-11:2006

NOTES: 3810 SERIES ELECTRONICS | EXTERNAL CONNECTIONS

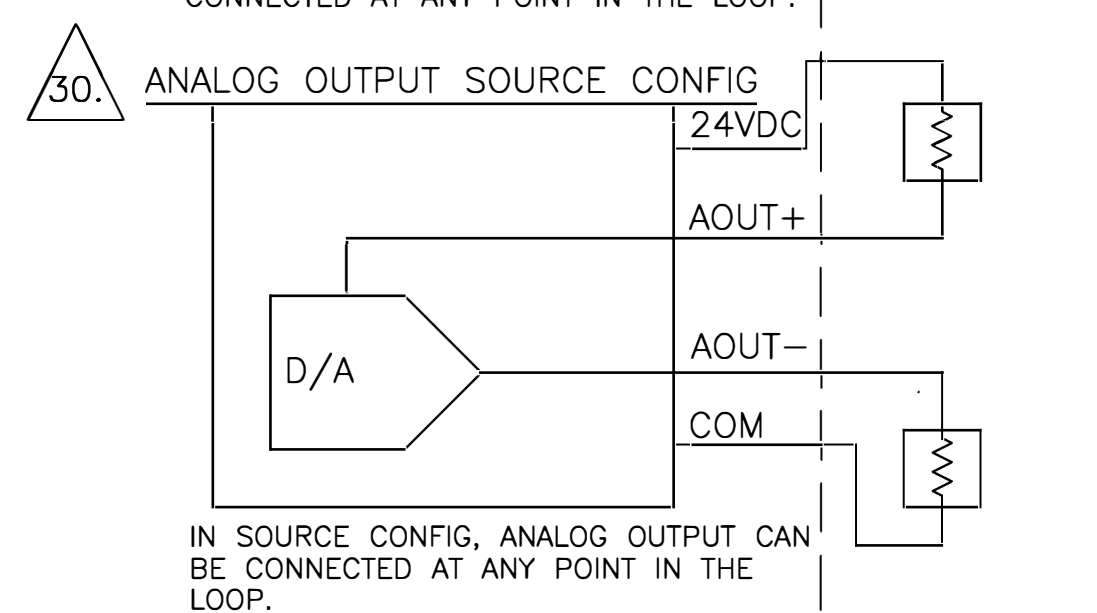
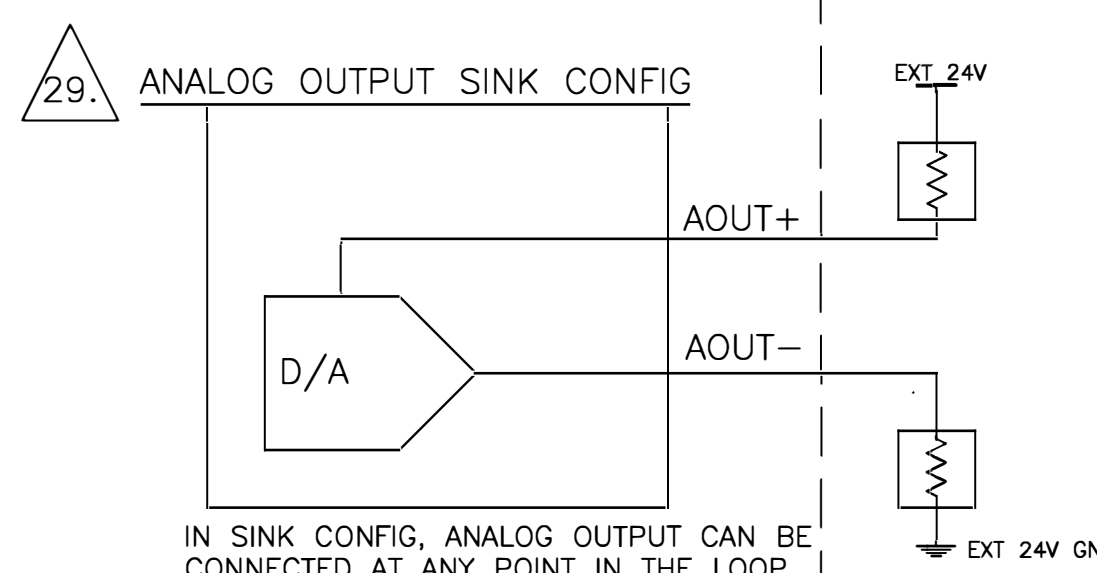
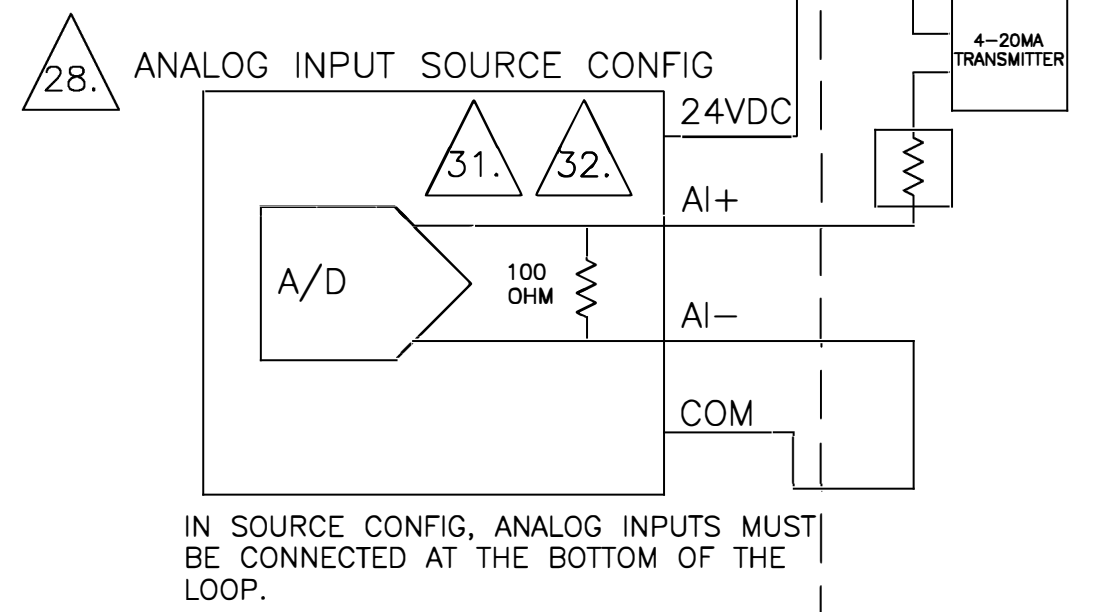
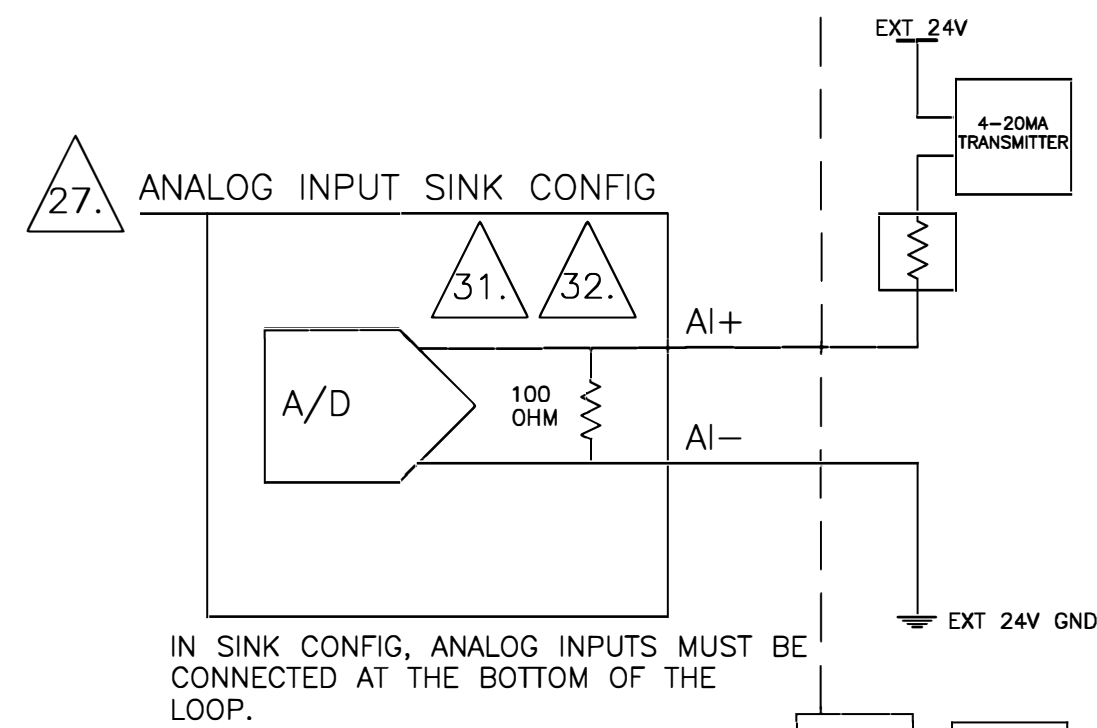

REPRESENTS ADDITIONAL I/O DEVICES LOCATED IN THE LOOP. ADDITIONAL DEVICES ONLY SHOWN TO ILLUSTRATE ANALOG CONNECTIONS. NOT REQUIRED FOR OPERATION

31. ANALOG INPUT 1 AND ANALOG INPUT 2 ARE FUNCTIONALLY IDENTICAL AND ARE NOT ELECTRICALLY ISOLATED FROM EACH OTHER. THE '-' TERMINALS FOR ANALOG INPUTS ARE COMMON TO EACH OTHER.

32. ANALOG INPUT 1 AND ANALOG INPUT 2 HAVE ADDITIONAL 150 OHMS LOOP IMPEDANCE FOR COMPLIANCE WITH HART COMMUNICATION REQUIREMENTS.

33. 24 VOLTS DC OUTPUT CAN BE USED TO SOURCE POWER TO ONE OR MORE OF THE ANALOG INPUTS OR OUTPUTS.

34. MODEL 3818: CABLING TO CONNECTORS J1, J2 AND J6 ON ACQUISITION MODULE SHALL HAVE DISCRETE WIRES RESTRAINED USING SHRINK TUBING AS SHOWN ON SHEET 2.

35. I/O CONFIGURATION CHANGES BASED ON CPU MODULE P/N. REFER TO PRODUCT MANUAL FOR FULL DETAILS.

36. EXPANSION MODULE HAS THREE ETHERNET PORT SWITCH WHERE PORT LABELED "3" IS INTENDED FOR CONNECTING TO ETHERNET PORT OF CPU MODULE, AND PORTS LABELED "1" AND "2" ARE AVAILABLE FOR USER.

37. SERIAL I/O MODULE INSTALLED IN SLOT 1 (ADJACENT TO CPU MODULE) IS PORT B, AND SERIAL I/O MODULE INSTALLED IN SLOT 2 IS PORT C. SLOT 2 IS ONLY AVAILABLE WITH RETROFIT ENCLOSURE OPTION.

SI METRIC								THIS DRAWING IN DESIGN AND DETAIL IS OUR PROPERTY AND MUST NOT BE USED EXCEPT IN CONNECTION WITH OUR WORK. IT SHALL NOT BE REPRODUCED AND SHALL BE RETURNED TO US ON DEMAND. ALL RIGHTS ARE RESERVED.	
THIRD ANGLE PROJECTION								GEOMETRIC TOLERANCES & DIMENSIONS PER ANSI Y14.5 LATEST REVISION	
								UNLESS OTHERWISE NOTED ALL DIMENSIONS IN INCHES X.XX ±.015 X.XXX ±.005 ANGULAR ±.5° 30' FINISH 200 RA MAX	
MATERIAL		BLOCK NOT APPLICABLE		J 11/23/15 KDG ECO DMC-1544 KVG KDG		H 11/20/15 KVG ECO DMC-1586 CV KDG		TITLE 3810 SERIES ULTRASONIC METER SYSTEM WIRING DIAGRAM	
FINISH		BLOCK NOT APPLICABLE		REV DATE DRN DESCRIPTION CHKD APPD		DRN KDG DATE 09/29/10 DWG NO. DMC-004936 CHKD KVG DATE 09/29/10 APPD KDG DATE 09/29/10 SCALE NA P/N		REV J	
PROJ. FILE NO. USM-01307		FILENAME: DMC004936J4.DWG, DATE: 11-23-15, TIME: 11:40 A.M.						SHT 4 OF 4	

Appendix B: Write-protected configuration parameters

B.1 Write-protected configuration

This appendix table lists configuration parameters that are write-protected against changes when the CPU Board WRITE PROT. switch in the **ON** position. Move the switch to the **OFF** position to write changes to the meter.

Table B-1 Write-protected configuration parameters

Write-protected configuration parameters	
AO1Content	AO2Content
AvgSoundVelHiLmt	AvgSoundVelloLmt
CalMethod	ColocMeterMode
ColocMeterSndVellimitPercent	DltChkSI
DeviceNumber	FwdA0
FwdA1	FwdA2
FwdA3	RevA0
RevA1	RevA2
RevA3	FlowAnalysisHighFlowLmt
FlowAnalysisLowFlowLmt	EnablePressureInput
EnableTemperatureInput	Freq1Content
Freq1Dir	Freq2Content
Freq2Dir	Freq3Content
Freq3Dir	Freq4Content
Freq4Dir	FwdMtrFctr1
FwdMtrFctr10	FwdMtrFctr11
FwdMtrFctr12	FwdMtrFctr2
FwdMtrFctr3	FwdMtrFctr4
FwdMtrFctr5	FwdMtrFctr6
FwdMtrFctr7	FwdMtrFctr8
FwdMtrFctr9	HARTQVContent
HARRateTimeUnit	HARTSlot0Content
HARTSlot1Content	HARTSlot2Content

Table B-1 Write-protected configuration parameters

HARTSlot3Content	HARTTVContent
HARTVolUnit	RefTempLinearExpCoef
LocalDisplayItem1	LocalDisplayItem10
LocalDisplayItem2	LocalDisplayItem3
LocalDisplayItem4	LocalDisplayItem5
LocalDisplayItem6	LocalDisplayItem7
LocalDisplayItem8	LocalDisplayItem9
LocalDisplayFlowRateTimeUnit	LocalDisplayVolUnitMetric
LocalDisplayVolUnitUS	MaxHoldTm
SSMax	MeterMaxVel
MinSigQlty	MinHoldTime
SNRatio	SSMin
UnitsSystem	VolFlowRateTimeUnit
FwdMtrFctr	RevMtrFctr
NegSpanSI	PkPlsWdthSI
Pk1Thrsh	PosSpanSI
RevMtrFctr1	RevMtrFctr10
RevMtrFctr11	RevMtrFctr12
RevMtrFctr2	RevMtrFctr3
RevMtrFctr4	RevMtrFctr5
RevMtrFctr6	RevMtrFctr7
RevMtrFctr8	RevMtrFctr9
SamplInterval	SampPerCycle
SetXdcrType	CRange
SndSpdChkMaxVel	SndSpdChkMinVel
SpecBatchUpdtPeriod	HighTemperatureAlarm
LowTemperatureAlarm	TmDevFctr1
TmDevLow1SI	Tspf
VolUnitMetric	VolUnitUS
XdcrFreq	ZeroFlowCalReqControl
ZeroFlowCalReqDuration	

Appendix C: Open source licenses

Source code for executable files or libraries included in this product is provided per the indicated license in the table below. Hyperlinks to the controlling organization's websites are included in [Section C.1](#) through [Section C.4](#).

Table C-1 Open source licences

Package	File specification	License	Summary
base_libs-1.2-1	base_libs	LGPL	Base Libraries (from toolchain)
busybox-1.1.3-1	busybox	GPL	A small executable that replaces many UNIX utilities
dev-1.1-1	dev	GPL	Device files for a small embedded system
devmem2-1.0-1	devmem2	GPL	Simple program to read/write from/to any location
ethtool-3-1	ethtool	GPL	Ethernet settings tool for PCI Ethernet cards
expat-2.0.1-1	expat	MIT	XML 1.0 parser
fake-provides-1.0-5	fake-provides	GPL	Fake provides to satisfy package dependencies
gdb-6.6cs-1	gdb	GPL	Gdb - GNU Source level debugger for C, C++
kernel-2.6.37-6	kernel-2.6.37-mpc8313erd	GPL	Linux kernel (core of the Linux operating system)
libpcap-0.8.3-1	libpcap	BSD	A system-independent interface for user-level pa
libtermcap-2.0.8-31_1	libtermcap	LGPL	A basic system library for accessing the termcap
lwIP		BSD	A lightweight TCP/IP stack
merge-0.1-1	merge	GPL	Merge files for an embedded root filesystem
modeps-1.0-1	modeps	GPL	Generate module dependency file
mtd-utils-20060302-1	mtd-utils	GPL	Memory Technology Device tools
net-tools-1.60-1	net-tools	GPL	Basic networking tools
ppp-2.4.4-1	ppp	BSD	Like a Point-to-Point Protocol daemon
skell-1.16-2	skell	GPL	Skeleton files for an embedded root filesystem
sqlite-3.6.22-1	sqlite	Public domain	SQLite is a C library that implements an embeddable SQL database

Package	File specification	License	Summary
strace-4.5.14-1	strace	BSD	trace system calls associated with a running pro
sysconfig-1.2-1	sysconfig	GPL	System configuration package
sysfsutils-2.1.0-1	sysfsutils	GPL/LGPL	sysfs utilities
tcpdump-3.8.3-1	tcpdump	BSD	A network traffic monitoring tool
termcap-1.2-1	termcap	BSD	minimal /etc/termcap needed by minicom etc
u-boot-1.3.0-1	u-boot-1.3.0-mpc8313erdb	GPL	Universal Bootloader firmware
ubi-utils-1.4.2-1	ubi-utils	GPL	Tools for maintaining Unsorted Block Image Device
vsftpd-2.2.2-1	vsftpd	GPL	vsftpd - Very Secure Ftp Daemon
zlib-1.2.3-2	zlib	zlib	Distribution zlib compression utilities and libraries

Follow the link below to the Rosemount Liquid Ultrasonic Products GPL webpage for additional open source information and zipped source code files.

<http://www2.emersonprocess.com/en-US/brands/emerson/Pages/GPL3810.aspx>

C.1 GNU General Public License

For more details about GNU GPL (General Public License), follow the link below:

<http://www.gnu.org/>

Emerson uses GPL version 2.

<http://www.gnu.org/licenses/old-licenses/gpl-2.0.html>

The GNU GPL is currently version 3

<http://www.gnu.org/licenses/quick-guide-gplv3.html>

For older versions of the GNU General Public License, follow the link below:

<http://www.gnu.org/licenses/old-licenses/old-licenses.html#GPL>

See GPL license on the following pages.

The GNU General Public License (GPL)

Version 2, June 1991

Copyright (C) 1989, 1991 Free Software Foundation, Inc.
59 Temple Place, Suite 330, Boston, MA 02111-1307 USA

Everyone is permitted to copy and distribute verbatim copies of this license document, but changing it is not allowed.

Preamble

The licenses for most software are designed to take away your freedom to share and change it. By contrast, the GNU General Public License is intended to guarantee your freedom to share and change free software--to make sure the software is free for all its users. This General Public License applies to most of the Free Software Foundation's software and to any other program whose authors commit to using it. (Some other Free Software Foundation software is covered by the GNU Library General Public License instead.) You can apply it to your programs, too.

When we speak of free software, we are referring to freedom, not price. Our General Public Licenses are designed to make sure that you have the freedom to distribute copies of free software (and charge for this service if you wish), that you receive source code or can get it if you want it, that you can change the software or use pieces of it in new free programs; and that you know you can do these things.

To protect your rights, we need to make restrictions that forbid anyone to deny you these rights or to ask you to surrender the rights. These restrictions translate to certain responsibilities for you if you distribute copies of the software, or if you modify it.

For example, if you distribute copies of such a program, whether gratis or for a fee, you must give the recipients all the rights that you have. You must make sure that they, too, receive or can get the source code. And you must show them these terms so they know their rights.

We protect your rights with two steps: (1) copyright the software, and (2) offer you this license which gives you legal permission to copy, distribute and/or modify the software.

Also, for each author's protection and ours, we want to make certain that everyone understands that there is no warranty for this free software. If the software is modified by someone else and passed on, we want its recipients to know that what they have is not the original, so that any problems introduced by others will not reflect on the original authors' reputations.

Finally, any free program is threatened constantly by software patents. We wish to avoid the danger that redistributors of a free program will individually obtain patent licenses, in effect making the program proprietary. To prevent this, we have made it clear that any patent must be licensed for everyone's free use or not licensed at all.

The precise terms and conditions for copying, distribution and modification follow.

TERMS AND CONDITIONS FOR COPYING, DISTRIBUTION AND MODIFICATION

0. This License applies to any program or other work which contains a notice placed by the copyright holder saying it may be distributed under the terms of this General Public License. The "Program", below, refers to any such program or work, and a "work based on the Program" means either the Program or any derivative work under copyright law: that is to say, a work containing the Program or a portion of it, either verbatim or with modifications and/or translated into another language. (Hereinafter, translation is included without limitation in the term "modification".) Each licensee is addressed as "you".

Activities other than copying, distribution and modification are not covered by this License; they are outside its scope. The act of running the Program is not restricted, and the output from the Program is covered only if its contents constitute a work based on the Program (independent of having been made by running the Program). Whether that is true depends on what the Program does.

1. You may copy and distribute verbatim copies of the Program's source code as you receive it, in any medium, provided that you conspicuously and appropriately publish on each copy an appropriate copyright notice and disclaimer of warranty; keep intact all the notices that refer to this License and to the absence of any warranty; and give any other recipients of the Program a copy of this License along with the Program.

You may charge a fee for the physical act of transferring a copy, and you may at your option offer warranty protection in exchange for a fee.

2. You may modify your copy or copies of the Program or any portion of it, thus forming a work based on the Program, and copy and distribute such modifications or work under the terms of Section 1 above, provided that you also meet all of these conditions:

- a) You must cause the modified files to carry prominent notices stating that you changed the files and the date of any change.
- b) You must cause any work that you distribute or publish, that in whole or in part contains or is derived from the Program or any part thereof, to be licensed as a whole at no charge to all third parties under the terms of this License.
- c) If the modified program normally reads commands interactively when run, you must cause it, when started running for such interactive use in the most ordinary way, to print or display an announcement including an appropriate copyright notice and a notice that there is no warranty (or else, saying that you provide a warranty) and that users may redistribute the program under these conditions, and telling the user how to view a copy of this License. (Exception: if the Program itself is interactive but does not normally print such an announcement, your work based on the Program is not required to print an announcement.)

These requirements apply to the modified work as a whole. If identifiable sections of that work are not derived from the Program, and can be reasonably considered independent and separate works in themselves, then this License, and its terms, do not apply to those sections when you distribute them as separate works. But when you distribute the same sections as part of a whole which is a work based on the Program, the distribution of the whole must be on the terms of this License, whose permissions for other licensees extend to the entire whole, and thus to each and every part regardless of who wrote it.

Thus, it is not the intent of this section to claim rights or contest your rights to work written entirely by you; rather, the intent is to exercise the right to control the distribution of derivative or collective works based on the Program.

In addition, mere aggregation of another work not based on the Program with the Program (or with a work based on the Program) on a volume of a storage or distribution medium does not bring the other work under the scope of this License.

3. You may copy and distribute the Program (or a work based on it, under Section 2) in object code or executable form under the terms of Sections 1 and 2 above provided that you also do one of the following:

- a) Accompany it with the complete corresponding machine-readable source code, which must be distributed under the terms of Sections 1 and 2 above on a medium customarily used for software interchange; or,
- b) Accompany it with a written offer, valid for at least three years, to give any third party, for a charge no more than your cost of physically performing source distribution, a complete machine-readable copy of the corresponding source code, to be distributed under the terms of Sections 1 and 2 above on a medium customarily used for software interchange; or,
- c) Accompany it with the information you received as to the offer to distribute corresponding source code. (This alternative is allowed only for noncommercial distribution and only if you received the program in object code or executable form with such an offer, in accord with Subsection b above.)

The source code for a work means the preferred form of the work for making modifications to it. For an executable work, complete source code means all the source code for all modules it contains, plus any associated interface definition files, plus the scripts used to control compilation and installation of the executable. However, as a special exception, the source code distributed need not include anything that is normally distributed (in either source or binary form) with the major components (compiler, kernel, and so on) of the operating system on which the executable runs, unless that component itself accompanies the executable.

If distribution of executable or object code is made by offering access to copy from a designated place, then offering equivalent access to copy the source code from the same place counts as distribution of the source code, even though third parties are not compelled to copy the source along with the object code.

4. You may not copy, modify, sublicense, or distribute the Program except as expressly provided under this License. Any attempt otherwise to copy, modify, sublicense or distribute the Program is void, and will automatically terminate your rights under this License. However, parties who have received copies, or rights, from you under this License will not have their licenses terminated so long as such parties remain in full compliance.

5. You are not required to accept this License, since you have not signed it. However, nothing else grants you permission to modify or distribute the Program or its derivative works. These actions are prohibited by law if you do not accept this License. Therefore, by modifying or distributing the Program (or any work based on the Program), you indicate your acceptance of this License to do so, and all its terms and conditions for copying, distributing or modifying the Program or works based on it.

6. Each time you redistribute the Program (or any work based on the Program), the recipient automatically receives a license from the original licensor to copy, distribute or modify the Program subject to these terms and conditions. You may not impose any further restrictions on the recipients' exercise of the rights granted herein. You are not responsible for enforcing compliance by third parties to this License.

7. If, as a consequence of a court judgment or allegation of patent infringement or for any other reason (not limited to patent issues), conditions are imposed on you (whether by court order, agreement or otherwise) that contradict the conditions of this License, they do not excuse you from the conditions of this License. If you cannot distribute so as to satisfy simultaneously your obligations under this License and any other pertinent obligations, then as a consequence you may not distribute the Program at all. For example, if a patent license would not permit royalty-free redistribution of the

Program by all those who receive copies directly or indirectly through you, then the only way you could satisfy both it and this License would be to refrain entirely from distribution of the Program.

If any portion of this section is held invalid or unenforceable under any particular circumstance, the balance of the section is intended to apply and the section as a whole is intended to apply in other circumstances.

It is not the purpose of this section to induce you to infringe any patents or other property right claims or to contest validity of any such claims; this section has the sole purpose of protecting the integrity of the free software distribution system, which is implemented by public license practices. Many people have made generous contributions to the wide range of software distributed through that system in reliance on consistent application of that system; it is up to the author/donor to decide if he or she is willing to distribute software through any other system and a licensee cannot impose that choice.

This section is intended to make thoroughly clear what is believed to be a consequence of the rest of this License.

8. If the distribution and/or use of the Program is restricted in certain countries either by patents or by copyrighted interfaces, the original copyright holder who places the Program under this License may add an explicit geographical distribution limitation excluding those countries, so that distribution is permitted only in or among countries not thus excluded. In such case, this License incorporates the limitation as if written in the body of this License.

9. The Free Software Foundation may publish revised and/or new versions of the General Public License from time to time. Such new versions will be similar in spirit to the present version, but may differ in detail to address new problems or concerns.

Each version is given a distinguishing version number. If the Program specifies a version number of this License which applies to it and "any later version", you have the option of following the terms and

conditions either of that version or of any later version published by the Free Software Foundation. If the Program does not specify a version number of this License, you may choose any version ever published by the Free Software Foundation.

10. If you wish to incorporate parts of the Program into other free programs whose distribution conditions are different, write to the author to ask for permission. For software which is copyrighted by the Free Software Foundation, write to the Free Software Foundation; we sometimes make exceptions for this. Our decision will be guided by the two goals of preserving the free status of all derivatives of our free software and of promoting the sharing and reuse of software generally.

NO WARRANTY

11. BECAUSE THE PROGRAM IS LICENSED FREE OF CHARGE, THERE IS NO WARRANTY FOR THE PROGRAM, TO THE EXTENT PERMITTED BY APPLICABLE LAW. EXCEPT WHEN OTHERWISE STATED IN WRITING THE COPYRIGHT HOLDERS AND/OR OTHER PARTIES PROVIDE THE PROGRAM "AS IS" WITHOUT WARRANTY OF ANY KIND, EITHER EXPRESSED OR IMPLIED, INCLUDING, BUT NOT LIMITED TO, THE IMPLIED WARRANTIES OF MERCHANTABILITY AND FITNESS FOR A PARTICULAR PURPOSE. THE ENTIRE RISK AS TO THE QUALITY AND PERFORMANCE OF THE PROGRAM IS WITH YOU. SHOULD THE PROGRAM PROVE DEFECTIVE, YOU ASSUME THE COST OF ALL NECESSARY SERVICING, REPAIR OR CORRECTION.

12. IN NO EVENT UNLESS REQUIRED BY APPLICABLE LAW OR AGREED TO IN WRITING WILL ANY COPYRIGHT HOLDER, OR ANY OTHER PARTY WHO MAY MODIFY AND/OR REDISTRIBUTE THE PROGRAM AS PERMITTED ABOVE, BE LIABLE TO YOU FOR DAMAGES, INCLUDING ANY GENERAL, SPECIAL, INCIDENTAL OR CONSEQUENTIAL DAMAGES ARISING OUT OF THE USE OR INABILITY TO USE THE PROGRAM (INCLUDING BUT NOT LIMITED TO LOSS OF DATA OR DATA BEING RENDERED INACCURATE OR LOSSES SUSTAINED BY YOU OR THIRD PARTIES OR A FAILURE OF THE PROGRAM TO OPERATE WITH ANY OTHER PROGRAMS), EVEN IF SUCH HOLDER OR OTHER PARTY HAS BEEN ADVISED OF THE POSSIBILITY OF SUCH DAMAGES.

END OF TERMS AND CONDITIONS

How to Apply These Terms to Your New Programs

If you develop a new program, and you want it to be of the greatest possible use to the public, the best way to achieve this is to make it free software which everyone can redistribute and change under these terms.

To do so, attach the following notices to the program. It is safest to attach them to the start of each source file to most effectively convey the exclusion of warranty; and each file should have at least the "copyright" line and a pointer to where the full notice is found.

One line to give the program's name and a brief idea of what it does.

Copyright (C) <year> <name of author>

This program is free software; you can redistribute it and/or modify it under the terms of the GNU General Public License as published by the Free Software Foundation; either version 2 of the License, or (at your option) any later version.

This program is distributed in the hope that it will be useful, but WITHOUT ANY WARRANTY; without even the implied warranty of MERCHANTABILITY or FITNESS FOR A PARTICULAR PURPOSE. See the GNU General Public License for more details.

You should have received a copy of the GNU General Public License along with this program; if not, write to the Free Software Foundation, Inc., 59 Temple Place, Suite 330, Boston, MA 02111-1307 USA

Also add information on how to contact you by electronic and paper mail.

If the program is interactive, make it output a short notice like this when it starts in an interactive mode:

Gnomovision version 69, Copyright (C) year name of author Gnomovision comes with ABSOLUTELY NO WARRANTY; for details type `show w'. This is free software, and you are welcome to redistribute it under certain conditions; type `show c' for details.

The hypothetical commands ``show w'` and ``show c'` should show the appropriate parts of the General Public License. Of course, the commands you use may be called something other than ``show w'` and ``show c'`; they could even be mouse-clicks or menu items--whatever suits your program.

You should also get your employer (if you work as a programmer) or your school, if any, to sign a "copyright disclaimer" for the program, if necessary. Here is a sample; alter the names:

Yoyodyne, Inc., hereby disclaims all copyright interest in the program ``Gnomovision'` (which makes passes at compilers) written by James Hacker.

signature of Ty Coon, 1 April 1989
Ty Coon, President of Vice

This General Public License does not permit incorporating your program into proprietary programs. If your program is a subroutine library, you may consider it more useful to permit linking proprietary applications with the library. If this is what you want to do, use the GNU Library General Public License instead of this License.

C.2 GNU Lesser General Public License

GNU LESSER GENERAL PUBLIC LICENSE

Version 3, 29 June 2007

Copyright © 2007 Free Software Foundation, Inc. <<http://fsf.org/>>

Everyone is permitted to copy and distribute verbatim copies of this license document, but changing it is not allowed.

This version of the GNU Lesser General Public License incorporates the terms and conditions of version 3 of the GNU General Public License, supplemented by the additional permissions listed below.

0. Additional Definitions.

As used herein, "this License" refers to version 3 of the GNU Lesser General Public License, and the "GNU GPL" refers to version 3 of the GNU General Public License.

"The Library" refers to a covered work governed by this License, other than an Application or a Combined Work as defined below.

An "Application" is any work that makes use of an interface provided by the Library, but which is not otherwise based on the Library. Defining a subclass of a class defined by the Library is deemed a mode of using an interface provided by the Library.

A "Combined Work" is a work produced by combining or linking an Application with the Library. The particular version of the Library with which the Combined Work was made is also called the "Linked Version".

The "Minimal Corresponding Source" for a Combined Work means the Corresponding Source for the Combined Work, excluding any source code for portions of the Combined Work that, considered in isolation, are based on the Application, and not on the Linked Version.

The "Corresponding Application Code" for a Combined Work means the object code and/or source code for the Application, including any data and utility programs needed for reproducing the Combined Work from the Application, but excluding the System Libraries of the Combined Work.

1. Exception to Section 3 of the GNU GPL.

You may convey a covered work under sections 3 and 4 of this License without being bound by section 3 of the GNU GPL.

2. Conveying Modified Versions.

If you modify a copy of the Library, and, in your modifications, a facility refers to a function or data to be supplied by an Application that uses the facility (other than as an argument passed when the facility is invoked), then you may convey a copy of the modified version:

"a) under this License, provided that you make a good faith effort to ensure that, in the event an Application does not supply the function or data, the facility still operates, and performs whatever part of its purpose remains meaningful, or

"b) under the GNU GPL, with none of the additional permissions of this License applicable to that copy.

3. Object Code Incorporating Material from Library Header Files.

The object code form of an Application may incorporate material from a header file that is part of the Library. You may convey such object code under terms of your choice, provided that, if the incorporated material is not limited to numerical parameters, data structure layouts and accessors, or small macros, inline functions and templates (ten or fewer lines in length), you do both of the following:

a) Give prominent notice with each copy of the object code that the Library is used in it and that the Library and its use are covered by this License.

b) Accompany the object code with a copy of the GNU GPL and this license document.

4. Combined Works.

You may convey a Combined Work under terms of your choice that, taken together, effectively do not restrict modification of the portions of the Library contained in the Combined Work and reverse engineering for debugging such modifications, if you also do each of the following:

- a) Give prominent notice with each copy of the Combined Work that the Library is used in it and that the Library and its use are covered by this License.
- b) Accompany the Combined Work with a copy of the GNU GPL and this license document.
- c) For a Combined Work that displays copyright notices during execution, include the copyright notice for the Library among these notices, as well as a reference directing the user to the copies of the GNU GPL and this license document.
- d) Do one of the following:
 - 0) Convey the Minimal Corresponding Source under the terms of this License, and the Corresponding Application Code in a form suitable for, and under terms that permit, the user to recombine or relink the Application with a modified version of the Linked Version to produce a modified Combined Work, in the manner specified by section 6 of the GNU GPL for conveying Corresponding Source.
 - 1) Use a suitable shared library mechanism for linking with the Library. A suitable mechanism is one that (a) uses at run time a copy of the Library already present on the user's computer system, and (b) will operate properly with a modified version of the Library that is interface-compatible with the Linked Version.
 - e) Provide Installation Information, but only if you would otherwise be required to provide such information under section 6 of the GNU GPL, and only to the extent that such information is necessary to install and execute a modified version of the Combined Work produced by recombining or relinking the Application with a modified version of the Linked Version. (If you use option 4d0, the Installation Information must accompany the Minimal Corresponding Source and Corresponding Application Code. If you use option 4d1, you must provide the Installation Information in the manner specified by section 6 of the GNU GPL for conveying Corresponding Source.)

5. Combined Libraries.

You may place library facilities that are a work based on the Library side by side in a single library together with other library facilities that are not Applications and are not covered by this License, and convey such a combined library under terms of your choice, if you do both of the following:

- a) Accompany the combined library with a copy of the same work based on the Library, uncombined with any other library facilities, conveyed under the terms of this License.
- b) Give prominent notice with the combined library that part of it is a work based on the Library, and explaining where to find the accompanying uncombined form of the same work.

6. Revised Versions of the GNU Lesser General Public License.

The Free Software Foundation may publish revised and/or new versions of the GNU Lesser General Public License from time to time. Such new versions will be similar in spirit to the present version, but may differ in detail to address new problems or concerns.

Each version is given a distinguishing version number. If the Library as you received it specifies that a certain numbered version of the GNU Lesser General Public License "or any later version" applies to it, you have the option of following the terms and conditions either of that published version or of any later version published by the Free Software Foundation. If the Library as you received it does not specify a version number of the GNU Lesser General Public License, you may choose any version of the GNU Lesser General Public License ever published by the Free Software Foundation.

If the Library as you received it specifies that a proxy can decide whether future versions of the GNU Lesser General Public License shall apply, that proxy's public statement of acceptance of any version is permanent authorization for you to choose that version for the Library.

C.3 BSD Open Source License

For more details about the Open Source™ BSD license or the Open Source Initiative, follow the link below:

<http://www.opensource.org/licenses/bsd-license.php>

Copyright (c) <YEAR>, <OWNER>

All rights reserved.

- Redistribution and use in source and binary forms, with or without modification, are permitted provided that the following conditions are met:
- Redistributions of source code must retain the above copyright notice, this list of conditions and the following disclaimer.
- Redistributions in binary form must reproduce the above copyright notice, this list of conditions and the following disclaimer in the documentation and/or other materials provided with the distribution.
- Neither the name of Rosemount nor the names of its contributors may be used to endorse or promote products derived from this software without specific prior written permission.

THIS SOFTWARE IS PROVIDED BY THE COPYRIGHT HOLDERS AND CONTRIBUTORS "AS IS" AND ANY EXPRESS OR IMPLIED WARRANTIES, INCLUDING, BUT NOT LIMITED TO, THE IMPLIED WARRANTIES OF MERCHANTABILITY AND FITNESS FOR A PARTICULAR PURPOSE ARE DISCLAIMED. IN NO EVENT SHALL THE COPYRIGHT OWNER OR CONTRIBUTORS BE LIABLE FOR ANY DIRECT, INDIRECT, INCIDENTAL, SPECIAL, EXEMPLARY, OR CONSEQUENTIAL DAMAGES (INCLUDING, BUT NOT LIMITED TO, PROCUREMENT OF SUBSTITUTE GOODS OR SERVICES; LOSS OF USE, DATA, OR PROFITS; OR BUSINESS INTERRUPTION) HOWEVER CAUSED AND ON ANY THEORY OF LIABILITY, WHETHER IN CONTRACT, STRICT LIABILITY, OR TORT (INCLUDING NEGLIGENCE OR OTHERWISE) ARISING IN ANY WAY OUT OF THE USE OF THIS SOFTWARE, EVEN IF ADVISED OF THE POSSIBILITY OF SUCH DAMAGE.

C.4 M.I.T License

For more details about the Open Source™ MIT license or the Open Source Initiative follow the link below:

<http://www.opensource.org/licenses/mit-license.php>

The MIT License

Copyright (c) <year> <copyright holders>

Permission is hereby granted, free of charge, to any person obtaining a copy of this software and associated documentation files (the "Software"), to deal in the Software without restriction, including without limitation the rights to use, copy, modify, merge, publish, distribute, sublicense, and/or sell copies of the Software, and to permit persons to whom the Software is furnished to do so, subject to the following conditions:

The above copyright notice and this permission notice shall be included in all copies or substantial portions of the Software.

THE SOFTWARE IS PROVIDED "AS IS", WITHOUT WARRANTY OF ANY KIND, EXPRESS OR IMPLIED, INCLUDING BUT NOT LIMITED TO THE WARRANTIES OF MERCHANTABILITY, FITNESS FOR A PARTICULAR PURPOSE AND NONINFRINGEMENT. IN NO EVENT SHALL THE AUTHORS OR COPYRIGHT HOLDERS BE LIABLE FOR ANY CLAIM, DAMAGES OR OTHER LIABILITY, WHETHER IN AN ACTION OF CONTRACT, TORT OR OTHERWISE, ARISING FROM, OUT OF OR IN CONNECTION WITH THE SOFTWARE OR THE USE OR OTHER DEALINGS IN THE SOFTWARE.

C.5 Zlib License

Copyright (C) 1995-2005 Jean-loup Gailly and Mark Adler

This software is provided 'as-is', without any express or implied warranty. In no event will the authors be held liable for any damages arising from the use of this software.

Permission is granted to anyone to use this software for any purpose, including commercial applications, and to alter it and redistribute it freely, subject to the following restrictions:

1. The origin of this software must not be misrepresented; you must not claim that you wrote the original software. If you use this software in a product, an acknowledgment in the product documentation would be appreciated but is not required.
2. Altered source versions must be plainly marked as such, and must not be misrepresented as being the original software.
3. This notice may not be removed or altered from any source distribution.

Appendix D: Index

D.1 Manual Index

Acronyms, abbreviations and definitions	3
AMS Device Manager - Manual Setup.....	88
AMST [™] Suite Device Manager	3
Analog	
input switch settings	62
output switch settings	62
Analog output settings	62
A	
Cable length	
Open Collector mode	45
TTL mode	45
Conduit seals	47
Configuration	75, 77
MeterLink Setup.....	77
Field Setup Wizard	78
open collector frequency outputs	45
protect switch setting	63
Seal the unit.....	100
C	
Cable length	
Open Collector mode	45
TTL mode	45
Conduit seals	47
Configuration	75, 77
MeterLink Setup.....	77
Field Setup Wizard	78
open collector frequency outputs	45
protect switch setting	63
Seal the unit.....	100
D	
Rosemount Hoist ring part numbers	38
MeterLink software.....	6
DHCP server	62
DHCP server switch settings.....	62
Digital Input.....	62
Digital Output(s).....	19
Dynamic Host Configuration Protocol	3
E	
Ethernet communications	55
External ground lug	47
F	
FCC Compliance	21
Frequency/Digital outputs.....	58
G	
GPL	105
H	
HART	3
Highway Addressable Remote Transducer.....	3
Hoist Ring Thread Size.....	38
Hoist rings	
American Drill Bushing Company	38
Carr Lane Manufacturing Company	38
Fastenal.....	38
Reid Tools.....	38
I	
I/O connections.....	57
Input/Output.....	3
Intrinsically Safe	3
L	
LGPL.....	105
Lifting slings.....	30
correct sling attachment	40
incorrect sling attachment.....	41
safety precautions using lifting slings.....	40
Local display	2
Display items.....	79
display labels, descriptions and valid units	79
Display units	81
Optional local display and glass endcap.....	14
Scroll delay	81
M	
MAC Address	4
Mechanical	
installation.....	23
Meter	15
Meter safety	
Appropriately rated lifting slings.....	40
Base Enclosure security seals	67
electronic enclosure security latch.....	65
end flanges tapped flat-counterbore hole	31
engineered swivel hoist rings	31
hoist ring and non-compliant eye bolt	32
hoist ring lookup table.....	38, 39
hoist rings in meter end flanges	31
hoist rings part number lookup table	38
how to obtain swivel hoist rings	38
incorrect sling attachment.....	41
Safety precautions using swivel hoist rings.....	33
Split shroud security seals	69, 70
swivel hoist rings	30
Transmitter Electronics Enclosure	
security seals	66
90 degree angle between slings	34
Meter specifications	15
analog Input(s).....	18
analog output(s).....	19
connectivity.....	18
Digital Input(s).....	18
frequency output/digital outputs	19
power	16
temperature.....	16
transducers.....	17, 43
Meter tube considerations	
bi-directional flow	28
piping unidirectional flow	27
MMU	4
Mounting in heated or cooled pipelines	42

O

Open source licenses.....	105
BSD Open Source License.....	121
GNU General Public License.....	106
GNU Lesser General Public License.....	117
M.I.T License.....	122

P

Piping recommendations.....	26
bidirectional flow.....	28
unidirectional flow.....	27
Port A	
communications.....	56
Pre-installation considerations.....	20
Public domain.....	105

S

Safety.....	20
ATEX Directive 94/9/EC.....	20
FCC compliance.....	21
Seal the meter	
Latched band shroud security seals.....	70
Seal the Base electronics enclosure.....	67
Seal the shrouds.....	68
Sealing the unit.....	74
Section.....	75, 77
Securing end caps and shroud.....	64
Security seals	
Install security seals on the Base	
Electronics Enclosure.....	67
Install security seals on the shrouds.....	68
Serial Port A parameters.....	56
Shroud options.....	7
dual extend bracket latched	
double band shrouds.....	7
latched double band shrouds.....	7
latched single band shroud.....	7
split shroud.....	7, 8
Source code for executable files.....	105
Startup	
startup and configuration.....	45, 75, 77
systems that use flame-proof cable.....	51

T

Transducer	
LT-10 operating temperature.....	17
LT-10 Operating temperature range	
.....	43
LT-11 operating temperature.....	17, 43
LT-14 Operating temperature.....	17, 43
LT-15 Operating temperature.....	43
LT-16 operating temperature.....	17, 43
LT-17 operating temperature.....	17, 43
Transmitter Electronics Enclosure	
chassis ground.....	46, 49

U

Ultrasonic type.....	15
----------------------	----

W

Wiring and connections	
Ethernet cable to PC communication.....	55
Ethernet communications.....	55
Modbus ASCII.....	52
Modbus ASCII or RTU.....	52
PC to meter serial connection.....	57
PlantWeb® architecture.....	52
RS-485 full duplex.....	52
TCP/IP protocol.....	52
Wiring and I/O.....	52

Numerics

3810 Series meter	
accuracy limits.....	16
acquisition cable.....	17
body and flange pressure rating range (psi).....	16
communications.....	18
design.....	7
digital, analog, and frequency inputs.....	18
digital, analog, and frequency outputs.....	19
electronic specifications.....	16
flange types.....	16
linearity.....	16
meter performance.....	16
meter type.....	15
minimum operating pressure.....	16
pre-installation considerations.....	20
repeatability.....	16
specific gravity.....	16
specifications.....	15
temperature base electronic enclosure.....	16
velocity range.....	16

For more information: www.emerson.com

©2022 Emerson. All rights reserved.

Emerson Terms and Conditions of Sale are available upon request. The Emerson logo is a trademark and service mark of Emerson Electric Co. Rosemount is a mark of one of the Emerson family of companies. All other marks are the property of their respective owners.

ROSEMOUNT™

