

Bettis SCE300

Electric Actuator



Table of Contents

Section 1: General Safety Instructions

1.1	Intended Use.....	1
1.2	Terms and Conditions	2
1.3	Manufacturer's Liability	2
1.4	Identification.....	3
1.4.1	Water - Dust-Proof Version	3
1.4.2	Explosion-Proof Version.....	4
1.5	Applicable Standards and Regulations.....	6
1.6	Extract From the Standard.....	6
1.7	Manufacturer	6

Section 2: Machine Description

2.1	General	7
2.2	Principle of Operation	7
2.3	Electrical Operation	7
2.4	Manual Operation	8
2.5	Description of Main Parts	8
2.6	Optional Modules.....	9
2.7	Options Label.....	10

Section 3: Storage and Pre-Installation

3.1	Checks to be Carried Out when the Actuator is Received	11
3.2	Storage Procedure	11
3.2.1	General	11
3.2.2	Short-term Storage (less than one year).....	12
3.2.3	Long-term Storage (more than one year).....	12

Section 4: Installation

4.1	Checks to be Performed Before Installation	13
4.2	Working Condition.....	13
4.3	Mounting Base	14
4.4	Installation of the SCE300 Unit Onto a Valve.....	15
4.5	Manual Operation	16
4.6	Setting of the Angular Stroke: Mechanical Stops.....	17
4.7	Electrical Connections.....	18
4.8	Plant Requirements	19
4.9	Removal of the Terminal Board Enclosure	21
4.10	Cable Connections	22
4.11	Base Wiring Diagram.....	23
4.12	Cable Entries	24
4.13	Safety Instructions for Installation in Hazardous Areas.....	26
4.13.1	Instructions for Explosion-Proof Enclosures	26

Section 5: Lubrication

5.1	Lubrication Inspection.....	28
-----	-----------------------------	----

Section 6: Actuator Configuration

6.1	Removal of the Control Unit Cover	29
6.2	Local Configuration of the SCE300	30
6.2.1	SCE300 Default General Configuration	30
6.2.2	Close Limit Configuration by Position	33
6.2.3	Close Limit Configuration	33
6.2.4	Open Limit Configuration by Position	33
6.2.5	Open Limit Configuration	34
6.2.6	Close Limit Configuration by Torque	34
6.2.7	Open Limit Configuration by Torque	34
6.2.8	Stroking Time Selection in Closing.....	35
6.2.9	Stroking Time Selection in Opening.....	36
6.2.10	Setting of the Torque-Limiting Device in Closing	36
6.2.11	Configuration of the Torque Limiting Device in Opening.....	37
6.2.12	Reverse Mode Configuration	37
6.2.13	Actuator Model Selection	38
6.2.14	Blinker / Local Selector Configuration	40
6.2.15	Three-Wires (3-Wires) / Two-Wires (2-Wires) Remote Control Configuration	40
6.3	Configuration of the SCE300 via PDA / PC and 'A Manager' Software	41
6.4	Hardware Configuration for Monitor Relay	41

Section 7: Maintenance and Troubleshooting

7.1	Maintenance	42
7.1.1	Routine Maintenance (approximately every two years).....	42
7.1.2	Special Maintenance.....	43
7.2	Troubleshooting.....	43
7.2.1	The Electronics do not Switch on when Powered	43
7.2.2	24 V DC Output Voltage not Available at the Terminals.....	44
7.2.3	The Actuator does not Work from Remote Controls	44
7.2.4	The motor is Very Hot and does not Start	44
7.2.5	The Motor Runs but the Actuator does not Move the Valve.....	44
7.2.6	The Valve does not Seat Correctly.....	45
7.2.7	Excessive Torque for Valve Operation.....	45
7.2.8	The Actuator does not Stop in Fully Open or Fully Closed Position.....	45
7.2.9	Diagnostic LED	45

Section 8: Decommissioning

8.1	Disposal and Recycling	46
-----	------------------------------	----

Section 9: Parts List and Drawings

Section 1: General Safety Instructions

1.1 Intended Use

The Bettis SCE300 electric actuator is designed to operate any type of quarter-turn industrial valve (e.g. ball, butterfly, plug, control) used in a wide range of applications. Such applications range from heavy industrial (e.g. chemical, petrochemical plants, waterworks, water pipelines, waste paper plants) to commercial (e.g. food, brewing, heating, ventilation, air conditioning).

Emerson will not be liable for potential or actual damage or physical injury resulting from use in other than the designated applications or by a lack of care during installation, operation, adjustment, and maintenance of the machine. Such risks lie entirely with the user. Depending on the specific working conditions, additional precautions may be requested. Given that Emerson has no direct control over particular applications, operation, or maintenance conditions, it is the operator's responsibility to comply with all applicable safety rules.

Inform Emerson as a matter of urgency if you face unsafe situations not described in this IOM. It is the sole responsibility of the operator to ensure that local health and safety regulations are adhered to. The SCE300 is tested according to UNI EN ISO 1680. Noise level is less than 65 dB (grade A) at 1 m distance.

WARNING

Installation, configuration, commissioning, maintenance, and repairs must be performed by approved and qualified personnel only. 

The SCE300 electric actuator is designed in accordance with the applicable international rules and specifications, but the following regulations must nonetheless be observed:

- General and safety regulations
- Plant-specific regulations and requirements
- The proper use of personal and protective devices (glasses, clothing, gloves, etc.)
- The proper use of tools, lifting equipment, and transport equipment
- Electrical installation, use, and maintenance of the SCE300 must be conducted in accordance with the national legislation and statutory requirements related to the safe use of such an actuator (as applicable to the site of installation)
- Contact Emerson should further information and/or guidance regarding safe use of the SCE300 actuator be required.

CAUTION

The SCE300 contains parts and sub-assemblies susceptible to damage from electrostatic discharge (ESD). Before performing any type of work on the actuator, use ESD protection or discharge static electricity by providing physical contact to grounded metal.

1.2 Terms and Conditions

Emerson guarantees every product to be free from defects and to conform to current goods specifications. The warranty period is one year from the date of installation by the first user or eighteen months from the date of shipment to the first user, whichever occurs first.

No warranty is given for products subjected to improper storage, improper installation, misuse, or corrosion, or products that have been modified or repaired by unauthorized personnel. Repair work resulting from improper use will be charged at standard rates.

1.3 Manufacturer's Liability

Emerson declines all liability in the event of:

- Use of the actuator in a fashion that contravenes local safety at work legislation
- Incorrect installation, disregard for, or incorrect application of the instructions provided on the actuator nameplate and in this manual
- Modifications without Emerson's authorization
- Work done on the unit by unqualified or unsuitable persons

1.4 Identification

1.4.1 Water - Dust-Proof Version

The SCE300 actuator is designed and manufactured according to EN 60529 standards.

Specific types of protection are printed on the label as follows:

- IP66/68
- NEMA 4/4X/6 according to NEMA ICS6 / NEMA 250

Figure 1 Label For Application In Water - Dust-Proof Areas

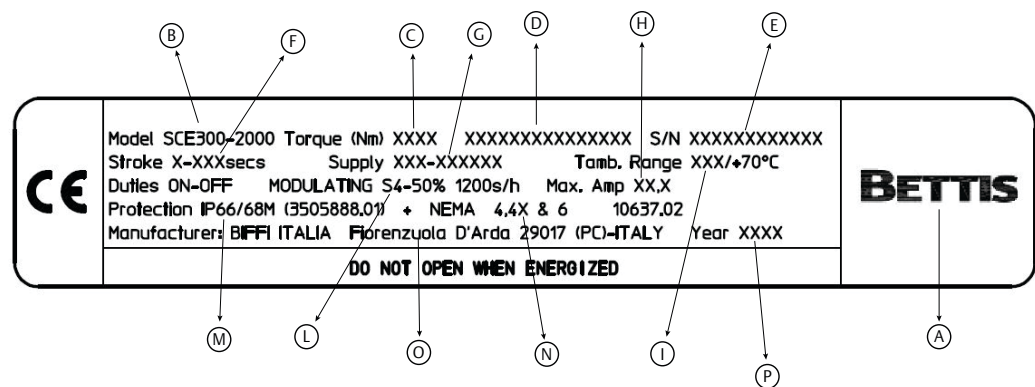

- A. Manufacturer logo
- B. Product model
- C. Nominal output torque value
- D. Product code
- E. Serial number
- F. Stroking time range
- G. Power supply data
- H. Max current absorption in ampere
- I. Environmental data
- L. Actuator duty
- M. Weather-proof protection degree (EU and US)
- N. Weather-proof certificate reference (EU and US)
- O. Manufacturer details
- P. Year of construction

1.4.2 Explosion-Proof Version

The version of the SCE300 suitable for installation in hazardous areas is designed and manufactured according to EN 60079-0, EN 60079-1, EN IEC 60079-7, EN 60079-3 standards.

Different types of protection are available, depending on the requirements of the installation site.

The driven valve or associated gear reducer will form part of a separate risk analysis in accordance with Directive 2014/34/EU, and follows the EN ISO 80079-36 and EN ISO 80079-37 norms.

Specific types of protection are printed on the label, as follows:

- ATEX Ex de IIB T5 with enclosures in explosion-proof version and terminal board enclosure in increased safety version
- FM rated as flame-proof for Class I, Zone 1, Group IIB, T5; Class II, III, Div. 1, Groups E, F and G, T4
- NEMA 7 and NEMA 9

The above versions of the SCE300 prevent the risk of explosion in the presence of gas or ignitable dusts. The SCE300 actuator possesses IP66/68 degree of protection in accordance with EN 60529.

WARNING

When installing the actuator in a hazardous area (as defined by the applicable rules), refer to the actuator nameplate to verify that certification, approval, and protections conform to site safety requirements.

WARNING

Installation, configuration, commissioning, maintenance, and repairs must be performed by approved and qualified personnel only.

Figure 2 Atex Label For Application In Hazardous Areas

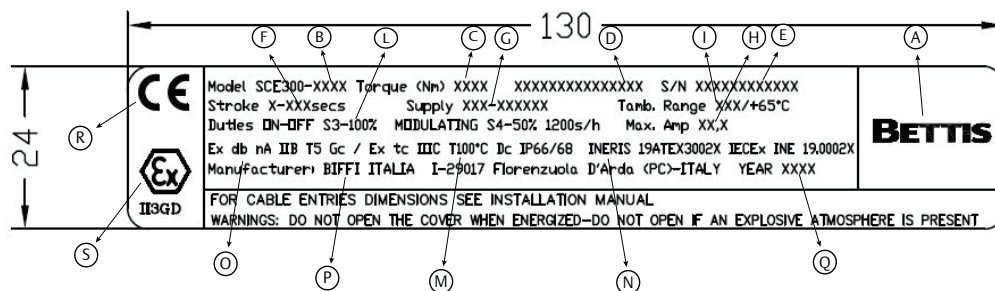

- A. Manufacturer logo
- B. Product model
- C. Nominal output torque value
- D. Product code
- E. Serial number
- F. Stroking time range
- G. Power supply data
- H. Max current absorption in ampere
- I. Environmental data
- L. Actuator duty
- M. Explosion-proof protection degree
- N. Weather-proof certificate reference (IP66/NEMA types 4, 4X and 6 when labeled FM)
- O. ATEX certificate reference
- P. Manufacturer details
- Q. Year of construction
- R. Notified body for ATEX quality assurance (Ineris)
- S. ATEX Marking

1.5 Applicable Standards and Regulations

EN ISO 12100-1	Safety of machinery Basic concepts, general principles for design Part 1 Basic terminology, methodology
EN ISO12100-2	Safety of machinery Basic concepts , general principles for design Part 2 Technical principles and specification
EN 60204-1	Electrical equipment of industrial machines Part 1 General requirements
98/37/EC	Machinery Directive
2014/35/EU	Low Voltage Directive
2014/53/EU	RED Directive
2014/34/EU	ATEX Directive

1.6 Extract From the Standard

Table 1.

Type of hazard zone	Zone	Categories according to 94/9/EC Directive
Gas, mist or vapors	0	1G
Gas, mist or vapors	1	2G
Gas, mist or vapors	2	3G
Dust	20	1D
Dust	21	2D
Dust	22	3D

1.7 Manufacturer

Manufacturer with respect to Machinery Directive 2006/42/CE is Biffi Italia, as specified on the actuator label.

Section 2: Machine Description

2.1 General

The SCE300 is an electric quarter-turn actuator suitable for operating a valve in a 90° stroke.

2.2 Principle of Operation

The electric motor drives the input to an epicyclical gear train via a spur reduction. The input member of the epicyclical gear train carries two compound planet gears which meshes with one internally toothed gear: the fixed annulus. The fixed annulus gear has external helical teeth that mesh with a transversely-fixed worm gear. Since the annulus cannot drive the worm gear, this provides a fixing point for the annulus; and since the worm gear can drive the annulus, a means of manual operation is provided that requires no declutch.

An end-of-travel-position detection device is operated via a position sensor directly linked to the output shaft. The valve position is continuously monitored in electric and manual mode by means of a position sensor directly connected to the SCE300 output drive.

2.3 Electrical Operation

- Control command 'open': counter-clockwise or clockwise rotation (selectable on the logic board) moves the valve to a fully or partially open position.
- Control command 'closed' : clockwise or counter-clockwise rotation (selectable on the logic board) moves the valve to a fully or partially closed position.
- Control system details are shown in the specific wiring diagram.

NOTICE

Standard rotation to close a quarter turn valve is the clockwise direction. The actuator handwheel rotation is the same as the output shaft rotation; i.e. $CW_{in} = CW_{out}$. Adhesive labels are included with the standard package for clockwise and counter-clockwise direction.

2.4 Manual Operation

Manual operation is to be used in cases of power supply failure or during actuator configuration. The manual operating device is completely independent of the motor drive and can be operated at any time - whether or not the motor is running - without danger to the operator. The handwheel does not rotate during power operation. To close the valve, turn the handwheel clockwise. To open the valve, turn the handwheel counter-clockwise. If the handwheel is turned while the actuator is under normal electric operation, an error will occur and the actuator will stop. After a few seconds, the actuator will restart operation and move the valve to the requested position.

Figure 3



2.5 Description of Main Parts

The SCE300 actuator consists of five main parts:

- Base flange: for coupling the actuator to the valve
- Terminals enclosure: for power and signal cable connection through four available cable entries
- Mechanical gearing: internal epicyclical gear reduction, which increases the torque of the electric motor
- Control unit: integral control unit, including an electric motor with the relevant driver, power, and logic electronic card. By means of mechanical gearing, the electric motor operates the valve in normal working conditions
- Manual override: for actuator manual operation in cases of power supply failure or during actuator configuration

2.6 Optional Modules

SCE300 actuators can be provided with several optional modules, as listed in the table below. Refer to this table for possible combinations of available modules.

Table 2. Optional Module Selection Table

Order code for standard plugs	Order code for metal plugs	OM1 I/O additional module	OM3 local interface	Bluetooth component	OM9 PDP V0/V1	OM11 DeviceNet	OM13 3-wires module
P1	Q1	✓					
PA	QA	✓	✓	✓			
P6	Q6	✓	✓				
P7	Q7	✓		✓			
P3	Q3		✓				
5P	7P			✓	✓		
6P	8P		✓	✓	✓		
5D	7D			✓		✓	
6D	8D		✓	✓		✓	
PG	QG						✓

NOTE

- Each optional module (OMx) will be provided with its own Installation and Maintenance Instructions. All modules except OM13 are available for both 1-phase and 3-phase voltage versions.
- OM1 board is available with and without Bluetooth feature. OM9 and OM11 are both available with Bluetooth feature; Bluetooth component is not available for integration by local organizations as stand alone unit.
- OM13 is only available for HV single phase 100-240 units.

2.7 Options Label

A label depicting all possible options is always provided with the base SCE300 actuator. If a module(s) is installed after the actuator has been delivered, the local operator must mark the label to show that the relevant module(s) were installed.

Figure 4

Options Label		
S/N:		
OM1	OM3	OM9
OM11	OM13	

Figure 5

Ensure that the label is applied in the area shown in the picture below.



Section 3: Storage and Pre-Installation

3.1 Checks to be Carried Out when the Actuator is Received

NOTE

Failure to follow the procedures as prescribed in this document will invalidate the product warranty.

First, check if the data on the nameplate (model, serial number, nominal torque, nominal voltage range, protection degree, operating speed range, protection class, etc.) corresponds to the expected product data.

If the actuator is received already assembled onto the valve, the setting of the mechanical stops and of the electric end-of-travel should have been already done during actuator assembly onto the valve. An additional check is always recommended to verify that all the requested settings have been implemented as indicated in the latest Instruction and Operating Manual.

If the actuator is received separately from the valve, the setting of the mechanical stops and of the electric end-of-travel must be checked and, if necessary, performed while assembling the actuator onto the valve. In any case, all the setting operations described in this Instruction and Operating Manual must be carried out. Check that the actuator was not damaged during transport; in particular, inspect the local position indicator area glass. If necessary, repair all damage (e.g. damage to the coat of paint). Check that the fitted accessories comply with those listed in the order acknowledgement and the delivery note.

3.2 Storage Procedure

3.2.1 General

The actuator leaves the factory in perfect working condition and with an excellent exterior finish. In order to maintain these characteristics until the time comes to install the actuator on-site, it is necessary to observe a few rules and take appropriate storage measures.

The basic version of SCE300 actuator is weather-proof to IP66/68M. This condition can only be maintained if the unit is correctly installed and connected on-site and if the unit was previously correctly stored. The standard plastic plugs used to close the cable entries are not weather-proof; these plugs are only intended to prevent the entry of foreign objects during transport. Emerson cannot accept responsibility for deterioration caused on-site when the covers are removed.

CAUTION

The actuator handwheel is removed for transport to avoid damage. When the actuator must be shipped with the handwheel assembled, ensure that the actuator assembly is properly packed to avoid damage to the handwheel.

3.2.2 Short-term Storage (less than one year)

3.2.2.1 Indoor Storage

- Ensure that the actuator is kept in a dry place, laid on a wooden pallet (not directly on the floor surface) and protected from dust
- In very humid environments, a moisture-absorbent desiccant packet should be introduced in the motor enclosure (desiccant is not included in the actuator package)

3.2.2.2 Outdoor Storage

- Ensure that the actuator is protected from potential environmental damage (e.g. protect the actuator with a canvas tarp). Note that the environmental temperature rating ranges from - 20 °C to +65 °C (-4 °F to 149 °F)
- Place the actuator on a wooden pallet (or some other raised platform) such that it is not in direct contact with the ground and is protected from dust
- In very humid environments, a moisture-absorbent desiccant packet should be introduced in the motor enclosure (desiccant is not included in the actuator package)
- If the actuator is supplied with standard plastic plugs, remove them from the cable entries and replace them with weather-proof plugs

3.2.3 Long-term Storage (more than one year)

3.2.3.1 Indoor Storage

In addition to the instructions from Section 3.2.2.1:

- If the actuator is supplied with standard plastic plugs, replace these plugs with weather-proof plugs
- The coupling parts (e.g. flange) must be coated with a protective oil or grease; if possible, cover the flange with a protective disc

3.2.3.2 Outdoor Storage

In addition to the instructions from Section 3.2.2.2:

- If the actuators are supplied with standard plastic plugs, replace these plugs with weather-proof (metal) plugs
- The coupling parts (e.g. flange) must be coated with a protective oil or grease; if possible, cover the flange with a protective disc
- Check the actuator general condition, paying particular attention to the terminal board

Section 4: Installation

4.1 Checks to be Performed Before Installation

To assemble the actuator onto the valve, proceed as follows:

- Check that the coupling dimensions of the valve flange and stem - or of the relevant extension - are compatible with the actuator coupling dimensions
- Check that the electrical supply cables are suitable for the power rating
- Gather the necessary tools for the assembly and configuration of the actuator controls
- Lubricate the valve stem with oil or grease to facilitate assembly; be careful not to contaminate the flange surfaces with lubricant (given that these surfaces transmit torque from the actuator)
- Clean the valve flange and remove anything that might prevent perfect adherence to the actuator flange (especially all traces of grease)
- Install the actuator onto the valve such that the shaft output drive enters the groove of the stem extension. This coupling must take place using only force from the weight of the actuator. When the actuator output shaft and the valve stem are connected, check the holes of the valve flange; if they do not meet with the holes of the spool piece flange or the stud bolts do not screw into them, the actuator shaft output drive must be rotated. Rotate the handwheel until bolt circles align. Tighten the nuts of the connecting stud bolts evenly
- If possible, operate the actuator to verify that it moves the valve smoothly

If a long storage period has occurred, prior to installing or re-installing the actuator:

- Check the condition of the O-ring seals
- Check for secure installation of the plugs or cable glands on the cable entries
- Check whether the enclosure covers or the actuator body are cracked or broken

4.2 Working Condition

Standard SCE300 actuators are suitable for the following environment temperatures:

- -25 °C to +70 °C (-13 °F to +158 °F)

Special versions are available for extreme environment temperatures:

- -40 °C to +70 °C (-40 °F to +158 °F)

4.3 Mounting Base

The SCE300 actuator is delivered with the drive details and flange as requested by the customer, and is ready to be installed onto the valve. Only one insert is included in the actuator package delivered to end users. Refer to Table 9 for the recommended torque for the mounting base bolts.

NOTICE

Installation in environments with temperatures outside the rated temperature will invalidate the warranty. Refer to the nameplate to verify the rated ambient temperature.

NOTICE

In case the screws of the cover, of the terminal compartment and of the OM3 must be replaced, SS Aisi 316 Class A4 grade 80 screw must be used with minimum yield strength 600 N/mm², the screw size is M6 X 25 mm. Other screws used for the assembly of the other various parts of the explosion proof enclosure shall be a SS AISI 316 Class A4 Grade 70, with minimum yield strength of 450 N/mm². Every time the main cover, the terminal compartment cover and the OM3 are reassembled, make sure to tight all the screws with 5 Nm torque.

NOTICE

For the model E171 and 2000 of the SCE300 Series only: during installation, the user shall take into consideration that the actuator was assessed at a low risk impact energy at 2J.

WARNING

During operation, the temperature of the actuator surface can reach 30 °C (86 °F) above the ambient temperature. Use proper PPE when handling high-temperature areas of the actuator.

CAUTION

Using fasteners other than the approved type may result in damage to the actuator or valve.

CAUTION

Failure to use proper torque values can result in damage to the actuator or valve.

Figure 6 Overview of the Valve Flange Mount**⚠ WARNING**

Never lift the valve/actuator assembly without securing slings to both the valve and the actuator. Never use the handwheel to lift the actuator.

4.4 Installation of the SCE300 Unit Onto a Valve

Move the valve to the completely open position. Manually bring the SCE300 to the completely open position (verify the local mechanical indicator) and check the rotation direction of actuator and valve. The actuator should be mounted for counter-clockwise rotation to open and clockwise rotation to close. The SCE300 unit can be installed onto the valve in two different ways:

Direct mounting

Insert the valve shaft into the actuator bottom flange, taking care to correctly connect the insert. Fix the screws on the valve flange to the actuator mounting base

Bracket mounting

Install the bracket and the adapter onto the valve; then, insert the valve shaft into the actuator bottom flange, taking care to correctly connect the insert. Fix the screws between the bracket, the valve flange and the actuator mounting base.

4.5 Manual Operation

The SCE300 actuator is supplied with a handwheel for manual override as standard, to operate the actuator in cases of power supply failure or during actuator configuration. The handwheel is always engaged; for safe operation, the handwheel does not rotate during electric operation. Turn the handwheel clockwise to close and counter-clockwise to open. During manual operation, check the actuator's motion or stroke on the local mechanical indicator.

⚠ WARNING

Do not manually operate the actuator with devices other than the handwheel. Using cheater bars, wheel wrenches, pipe wrenches, or other such devices on the actuator handwheel may cause serious personal injury and/or damage to the actuator or valve.

Figure 7 Manual Operation



4.6 Setting of the Angular Stroke: Mechanical Stops

It is important for the mechanical stops to end the angular stroke at both valve position extremes (i.e. fully open and fully closed). Setting of the angular stroke is performed by adjusting the travel stop screw mounted on the actuator housing. For the adjustment of the stop screw proceed as follows:

- Loosen the lock nut
- Screw 1: open
To set the mechanical stop for opening, manually bring the actuator to the completely open position, and then turn screw 1 clockwise to find the correct position, and then lock screw 1 down using the nut
- Screw 2: close
To set the mechanical stop for closing, manually bring the actuator to the completely closed position, and then tighten screw 2

If the actuator angular stroke is stopped before reaching the end position (fully open or closed), proceed as follows:

- Unscrew the stop screw by turning it counter-clockwise until the valve reaches the correct position
- When unscrewing the stop screw, keep the lock nut still with a wrench such that the sealing washer does not withdraw together with the screw
- Tighten the lock nut

If the actuator angular stroke is stopped beyond the end position (fully open or closed), proceed as follows:

- Screw the stop screw by turning it clockwise until the valve reaches the correct position
- Tighten the lock nut

Figure 8 Setting of the Mechanical Stop



4.7 Electrical Connections

Before powering the actuator, check that the supply voltage details on the nameplate are correct for the plant. Access to terminals for electrical connections is through the terminal cover.

WARNING

Installation, configuration, commissioning, maintenance, and repairs must be performed by approved and qualified personnel only.

WARNING

When performing maintenance or configuration on a powered-on actuator, beware of the potential electrical hazard. Use the correct tools and carefully follow the instructions in this manual.

NOTICE

When removing the cover assembly or terminal block cover on existing installations, follow the safety rules applicable to the site.

NOTICE

All accessories (including cable glands) must comply with the approved specifications for the site requirements and be certified according to the standard directive.

4.8 Plant Requirements

Protection devices (over-current breakers, magneto-thermal switches, or fuses) must be provided by the customer to protect the main lines in case of motor over-current or loss of insulation between phases and earth.

The following circuit breakers are identified on the basis of the actuator's technical features:

- Reference: IEC EN 60947-2
- Characteristic: K

NOTICE

Before any installation work takes place, ensure that the plant engineering staff or responsible party has selected the most appropriate electrical protection for the application site.

NOTICE

For actuators certified according to CSA standards, the field connections shall be done with certified crimp-on ring terminals.

Table 3. Current Absorption - Single-Phase and DC Voltage

Model	Selected Step	Operating Time (s/90°)	Current Absorption (A)											
			24V AC	48V AC	90V AC	110 VAC	230 VAC	264 VAC	24V DC	48V DC	90V DC	110 VDC	230V DC	264V DC
063/ E006	8	15	2.26	1.01	0.590	0.473	0.334	0.289	2.02	1.01	0.605	0.476	0.222	0.196
	6	28	1.60	0.84	0.405	0.334	0.253	0.217	1.53	0.75	0.415	0.343	0.158	0.138
	4	48	1.38	0.73	0.317	0.265	0.209	0.176	1.30	0.64	0.318	0.260	0.120	0.106
125/ E013	8	15	4.20	1.70	0.980	0.810	0.430	0.420	4.50	1.81	1.040	0.820	0.390	0.340
	6	28	2.60	1.28	0.780	0.630	0.370	0.340	2.65	1.27	0.810	0.640	0.300	0.260
	4	48	2.04	1.00	0.680	0.560	0.340	0.290	2.10	0.96	0.720	0.570	0.270	0.220
250/ E025	8	15	10.30	4.90	2.440	1.970	0.920	0.800	9.70	4.80	2.520	1.950	0.900	0.780
	6	28	8.20	3.80	1.650	1.350	0.640	0.570	7.20	3.60	1.650	1.320	0.630	0.540
	4	48	6.40	3.30	1.440	1.170	0.560	0.500	6.80	3.20	1.460	1.140	0.540	0.470
500/ E051	8	15	14.50	6.80	3.200	2.520	1.150	1.000	14.00	7.00	3.220	2.530	1.120	0.980
	6	28	9.50	4.60	1.900	1.550	0.760	0.670	9.30	4.50	1.920	1.540	0.720	0.620
	4	48	7.00	3.40	1.550	1.240	0.600	0.530	7.10	3.40	1.510	1.240	0.580	0.500
1000/ E091	8	24	14.50	6.80	3.200	2.520	1.150	1.000	14.00	7.00	3.220	2.530	1.120	0.980
	6	45	9.50	4.60	1.900	1.550	0.760	0.670	9.30	4.50	1.920	1.540	0.720	0.620
	4	80	7.00	3.40	1.550	1.240	0.600	0.530	7.10	3.40	1.510	1.240	0.580	0.500
2000/ E171	8	53	14.50	6.80	3.200	2.520	1.150	1.000	14.00	7.00	3.220	2.530	1.120	0.980
	6	100	9.50	4.60	1.900	1.550	0.760	0.670	9.30	4.50	1.920	1.540	0.720	0.620
	4	180	7.00	3.40	1.550	1.240	0.600	0.530	7.10	3.40	1.510	1.240	0.580	0.500

Table 4. Current Absorption - Three-Phase Voltage

Model	Selected Step	Operating Time (s/90°)	Current Absorption (A)						
			208 V AC	240 V AC	380 V AC	400 V AC	480 V AC	500 V AC	575 V AC
063/E006	8	15	0.226			0.176			0.107
	6	28	0.165			0.101			0.080
	4	48	0.132			0.083			0.057
125/E013	8	15	0.344			0.227			0.171
	6	28	0.295			0.180			0.143
	4	48	0.245			0.155			0.125
250/E025	8	15	0.800	0.73	0.52		0.49	0.37	0.340
	6	28	0.590	0.56	0.41		0.35	0.29	0.280
	4	48	0.530	0.50	0.37		0.30	0.27	0.250
500/E051	8	15	1.073	0.97	0.65		0.58	0.46	0.430
	6	28	0.720	0.64	0.47		0.39	0.32	0.310
	4	48	0.590	0.55	0.41		0.32	0.29	0.280
1000/E091	8	24	1.073	0.97	0.65		0.58	0.46	0.430
	6	45	0.720	0.64	0.47		0.39	0.32	0.310
	4	80	0.590	0.55	0.41		0.32	0.29	0.280
2000/E171	8	53	1.073	0.97	0.65		0.58	0.46	0.430
	6	100	0.720	0.64	0.47		0.39	0.32	0.310
	4	180	0.590	0.55	0.41		0.32	0.29	0.280

NOTE

1. A = absorbed current (Amp) at nominal conditions (output torque 100%)
2. Max current (Amp) at stall conditions = $1.2 \times A$
3. Power factor for V AC supply = 0.60
4. Peak current: max $8 \times I_n$
5. Peak current duration: less than 0.1 s

4.9 Removal of the Terminal Board Enclosure

Using a 5 mm Allen key, loosen the four screws and remove the cover.

Figure 9 Removal of the terminal board enclosure



NOTICE

When removing the cover assembly or terminal block cover on existing installations, follow all safety rules as pertaining to the site.

NOTICE

Be careful to not damage the joint surfaces of the terminal cover or seal during removal.

4.10 Cable Connections

Before applying voltage to the SCE300, check that the electrical parameters (supply voltage and current) shown on the nameplate and on the attached wiring diagram are correct for the installation.

Figure 10 Overview of the electrical connections

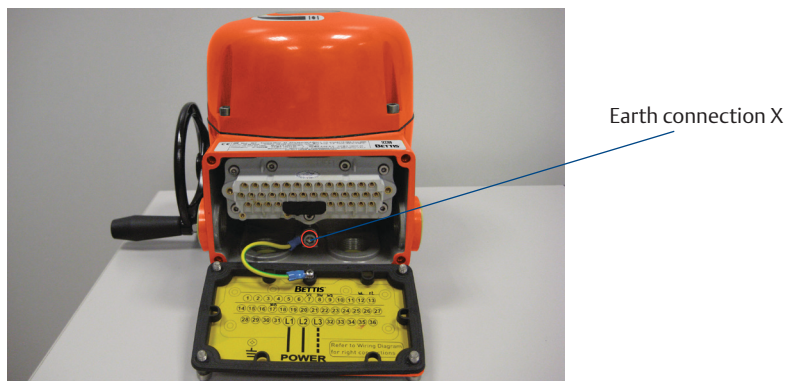

NOTICE

All accessories (including cable glands) must comply with the approved specifications for the site requirements and be certified according to the standard directive.

⚠ WARNING

Do not remove the earth connection or the cover ground while connecting the actuator to plant earthing.

Remove the plugs from the cable entries. For electrical connections use components (cable glands, cables, hoses, conduits) that meet the requirements and the applicable codes as specified by the plant (mechanical protection and/or explosion-proof protection). Screw the cable glands (or the conduits) tightly into the threaded entries, in order to guarantee weather-proof and explosion-proof protection (when applicable). Insert the connection cables into the electrical enclosures through the cable glands (or conduits). According to the wiring diagram in the main terminal board enclosure, connect the electrical supply, the control and the signal cables to the actuator by linking them to the terminal blocks as per said diagram.

Replace the plastic plugs of the unused cable entries with metal plugs, to guarantee perfect weather-proof protection and to comply with explosion-proof protection codes (where applicable). Once the connections are completed, check that the controls and signals work properly. Two ground studs, (one internal and one external) are provided to meet all local electric and safety regulations. Terminate the ground connections at a minimum to the external stud marked GROUND. Connect the motor supply cable previously sized in accordance with:

- The absorbed current that corresponds to the actuator nominal torque with the torque limiting device set at 100%
- Cable size: 1 power: 4 mm²/AWG12 (max) 2 controls: 1.5 mm²/AWG 16 (max)
- The applicable plant and safety norms
- For actuators certified according to CSA standards, the field connections shall be done with certified crimp-on ring terminals.

4.11 Base Wiring Diagram

Figure 11

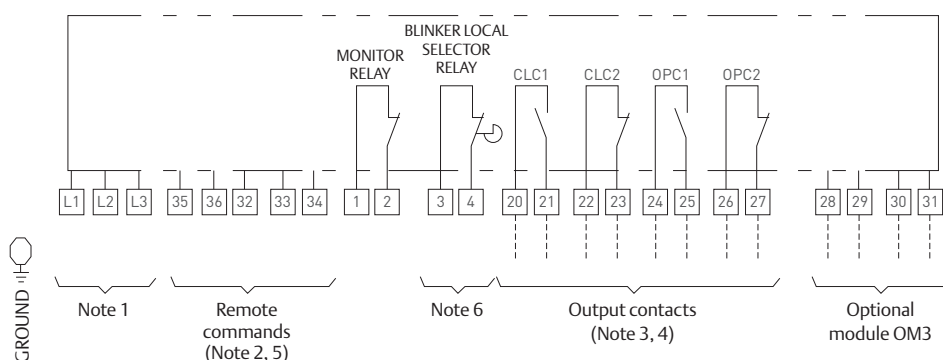

NOTE

1. Power connection L1-L2 for V DC or V AC single-phase motor supply from 24 V to 48 V or from 100 V to 240 V. Power connection L1-L2-L3 for three-phase motor supply from 208 V to 575 V (check the actuator label for the correct voltage to be applied).
2. Remote command options.
3. Contacts shown in intermediate position CLC1-CLC2 signal end of travel while closing. Contacts shown in intermediate position OPC1-OPC2 signal end of travel while opening.
4. Output contact rating 240 V AC / 5 A ; 30 V DC / 5A ; 120 V DC / 0.5 A. Output contacts (when used) have to be feed with the same external voltage.
5. Control command rating 24 to 120 V AC or DC.
6. Blinker or Local Selector monitoring function (when OM3 is present) must be configured.

Figure 12a Standard Configuration

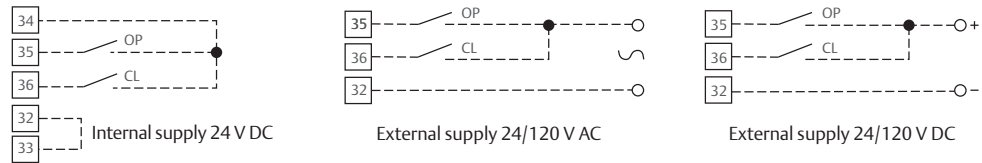
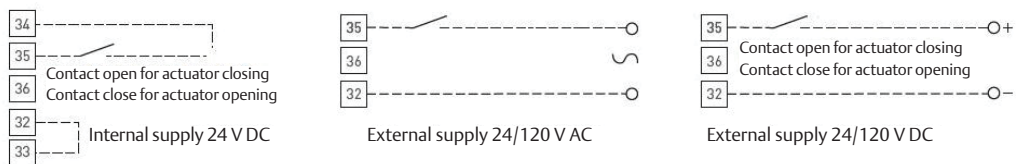

Figure 12b Two Wires Configuration (2-Wires)



⚠ WARNING

Power surges must not exceed 1500 Volts. It is the duty of the plant engineer or responsible party to select the most appropriate power surge protection.

4.12 Cable Entries

The sealing of cables and conduit entries should be carried out in accordance with the relevant national standards or the regulatory authorities that certified the actuators. This is particularly true for units that are certified for use in hazardous areas where the method of sealing must be to an approved standard, and cable glands, reducers, plugs, and adapters must be approved and separately certified.

If rigid conduits are used, it is recommended to place a flexible pipe connection between the conduit and the terminal board.

NOTICE

To prevent water infiltration through the cable conduits, ensure that the cable glands possess the minimum degree of protection as required by the plant.

NOTICE

In case the screws of the cover, of the terminal compartment and of the OM3 must be replaced, SS Aisi 316 Class A4 grade 80 screw must be used with minimum yield strength 600 N/mm², the screw size is M6 X 25 mm. Other screws used for the assembly of the other various parts of the explosion proof enclosure shall be a SS AISI 316 Class A4 Grade 70, with minimum yield strength of 450 N/mm². Every time the main cover, the terminal compartment cover and the OM3 are reassembled, make sure to tight all the screws with 5 Nm torque.

In order to properly connect the cables, remove the cable entry plugs and make all the necessary connections. To guarantee the a proper weather-proof fit, degree IP66/68 must be ensured: screw the cable glands tightly and coat them with a thread sealant. The use of a thread sealant is necessary in explosion-proof applications.

If some parts of the cable glands have been removed while working on the cable entries, put them back into place in order to avoid losing the dismantled parts. For unused entries:

- For explosion-proof construction: unused entries must be plugged with metal explosion-proof plugs and coated with a thread sealant
- For weather-proof construction: replace the standard plastic protection plugs supplied with the actuator with suitable plugs to guarantee the requested degree of protection

⚠ WARNING

Once all power cable connections have been made to the terminal block, position the power terminal protection to prevent accidental contact while wiring the signal terminals.

Figure 13 Overview of the cable entry conduits



4.13 Safety Instructions for Installation in Hazardous Areas

4.13.1 Instructions for Explosion-Proof Enclosures

NOTICE

Certain nameplates may carry more than one approval, and each approval may have unique installation/wiring requirements and/or conditions of “safe use”, installation, and maintenance. These special instructions are in addition to and may override the standard installation procedures. Special instructions are listed by approval type.

NOTICE

The SCE300 electric actuator must be installed and maintained according to the applicable rules regarding electrical installation in hazardous areas (other than mines) classified as zone 1 and/or 2 (gas) and zone 21 and/or 22 (dust) according to EN 60079-10 (hazardous area classification). For example: EN 60079-14 (electrical installation), EN 60079-17 (maintenance).

During the dismantling and subsequent reassembling of the explosion-proof enclosures (covers, cable glands, joints), take care to maintain these enclosures as close as possible to their original condition to maintain their integrity. In particular, ensure that the joint surfaces of all enclosures are spread with a film of recommended grease.

Proceed as follows:

- Do not damage the explosion-proof mating surfaces on the housing and on the electrical enclosure covers
- Reinstall all the screws associated with the dismantled parts, and coat them with a thread sealant after coating them with a film of copper- or molybdenum-based grease. This will prevent the screws from sticking and facilitate their removal when maintenance is required
- Check that the bolts and screws are of the same dimensions and at least equal quality as those originally installed (as stated on the nameplate)
- Replace any weather-proof seal, gaskets and o-rings that may have been removed

CAUTION

Using fasteners other than the approved type may result in damage to the actuator or valve.

⚠ CAUTION

Failure to use the recommended bolts tightening torque can result in damage to the actuator or valve.

⚠ CAUTION

Refer to the manufacturer for flamepath dimensions.

⚠ CAUTION

To reduce the risk of static ignition, only use anti static cloth for cleaning.

⚠ CAUTION

Using seals, gaskets and o-rings other than the approved type may result in damage to the actuator or valve.

⚠ DANGER

Do not electrically operate the actuator when the electrical enclosures are removed.
Do not open the actuator covers when an explosive atmosphere may be present. Ignoring the above precautions may result in personal injury or death.

NOTICE

The SCE300 electric actuator must be installed and maintained according to the applicable rules regarding electrical installation in hazardous areas (other than mines) classified as zone 21 and/or 22 (dust) according to EN 60079-10 (hazardous area classification).
For example: installation and maintenance according to EN 50281-1-2.

Pay special attention to the following:

- Before assembly, the joint surfaces must be greased with silicone oil or an equivalent
- Cable glands must possess the minimum degree of protection per IP66/68 (EN 60529)
- Periodically measure the quantity of dust deposited on the surface of the actuator body. Clean the dust with a damp cloth (to avoid inducing static electricity) if said dust accumulates to more than 5mm high (relative to the actuator body)

Section 5: Lubrication

5.1 Lubrication Inspection

The actuator is lubricated with grease for the entire duration of its service life; under normal working conditions, new grease need never be added (nor completely replaced).

For maintenance purposes, the following grease is recommended:

- AEROSHELL GREASE 7 or equivalent, for ambient temperature -40 °C to +70 °C (-40 °F to +158 °F).

Section 6: Actuator Configuration

Before connecting power to the actuator, check that the voltages are correct and correspond to the indications on the nameplate. An incorrect power supply could cause permanent damage to the electrical components.

Configuration of the SCE300 actuator can be conducted via the control panel inside the actuator control system. To access the panel, remove the actuator cover and when the configuration is complete, replace the cover by following the procedures indicated below.

When optional local control panel OM3 is installed and actuator configuration is conducted via the pushbuttons on the logic board, the remote controls do not have to be energized.

6.1 Removal of the Control Unit Cover

To remove the control unit cover, follow the below instructions:

- Using a 5 mm Allen key, loosen the four screws and remove the cover.
- When setting the actuator parameters, do not operate the actuator remotely or locally.
- When removing the control unit cover, care should be taken to not damage the joint surfaces of the cover.
- If the screws of the cover must be replaced, SS Class A4 grade 80 screws must be used with a minimum yield strength of 600N/mm² (87ksi).
- Once the configuration is complete, reassemble the actuator cover.

CAUTION

Using fasteners other than the approved type may result in damage to the actuator or valve.

CAUTION

Failure to use the recommended bolts tightening torque can result in damage to the actuator or valve.

Figure 14 Removal of the control unit cover

6.2 Local Configuration of the SCE300

⚠ CAUTION

Actuator configuration must be done while actuator is powered on. Do not touch any components not required for configuration to avoid injury or damage to equipment.

⚠ WARNING

Installation, configuration, commissioning, maintenance, and repairs must be performed by approved and qualified personnel only.

6.2.1 SCE300 Default General Configuration

The actuator is set in the factory to the following default configuration:

- CLOSE (CL) Limit Relay by position
- OPEN (OP) Limit relay by position
- Stroking time in CL (6): 28 s for models 063/125/250/500, 45 s for model 1000 and 100 s for model 2000
- Stroking time in OP (6): 28 s for models 063/125/250/500, 45 s for model 1000 and 100 s for model 2000
- Torque limiting device in CL set at about 100% of nominal torque
- Torque limiting device in OP set at about 100% of nominal torque
- Reverse mode off
- Monitor Relay NC (in normal condition, i.e. without alarms)
- Blinker / Local Selector relay off (always Open)

If the application requires a different actuator configuration(s), proceed as described in this section.

NOTICE

The actuator configuration does not need to be performed in the order as indicated by the following steps. Each parameter can be set independently.

Configuration of the actuator parameters is conducted via the following components:

- Two rotary selector switches SW6 and SW4 for actuator configuration
- Enter pushbutton SW5 (confirmation pushbutton)
- Dip switch SW3 (enable configuration function)
- Green LED indicating power ON (switched on when power supply is available)
- Red LED for Enter confirmation (ON once configuration is confirmed)
- Mechanical stops

Figure 15 Configuration of the actuator parameters

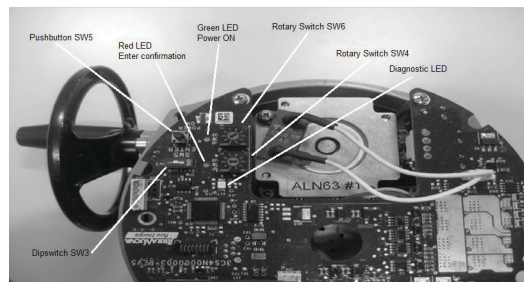

Table 5. Base Card Setup

Setup	Rotary switches position		Dip switch	Enter button	Default
	SW4	SW6	SW3	SW5	
Close limit	0	0	ON	PUSH	n.d.
Open limit	1	0	ON	PUSH	n.d.
L/S close	2	1: by position	ON	PUSH	1
	2	0: by torque	ON	PUSH	
L/S open	3	1: by position	ON	PUSH	1
	3	0: by torque	ON	PUSH	
Closing speed	4	4	ON	PUSH	
	4	6	ON	PUSH	6
	4	8	ON	PUSH	
Opening speed	5	4	ON	PUSH	
	5	6	ON	PUSH	6
	5	8	ON	PUSH	
% Closing torque	6	2: 50%	ON	PUSH	
	6	5: 75%	ON	PUSH	
	6	9: 100%	ON	PUSH	9
% Opening torque	7	2: 50%	ON	PUSH	
	7	5: 75%	ON	PUSH	
	7	9: 100%	ON	PUSH	9
CW/CCW	8	0: CW;	ON	PUSH	0
	8	1: CCW;	ON	PUSH	
Size	9	0: 63 Nm / 250 Nm	ON	PUSH	0
	9	1: 125 Nm / 500 Nm	ON	PUSH	0
	9	3: 1000 Nm	ON	PUSH	0
	9	4: 2000 Nm	ON	PUSH	0
Nm / lb-in	0	8: Nm	ON	PUSH	8
	0	9: lb-in	ON	PUSH	
Blinker / Local Selector	4	0: Off	ON	PUSH	0
	4	1: Blinker	ON	PUSH	
	4	2: Local Selector	ON	PUSH	
Heater	8	9: Active	ON	PUSH	9
	8	8: Not active	ON	PUSH	
Inversion colors LED of local control	9	2	ON	PUSH	LED Open: Green
					LED Close: Red
Remote Control	9	5 = 3-Wires	ON	PUSH	5
		6 = 2-Wires			

6.2.2 Close Limit Configuration by Position

Enter setup configuration:

- Move switch SW4 to position 2
- Move switch SW6 to position 1
- Move switch SW3 to position ON
- Confirm by pushing ENTER pushbutton SW5
- When pushing SW5, the red LED switches on for confirmation
- Exit setup configuration by moving switch SW3 to position 1 or proceed to the next parameter

6.2.3 Close Limit Configuration

- Move switch SW3 to position ON
- Drive the actuator to the closed position using the handwheel
- Move switch SW4 to position 0
- Move switch SW6 to position 0
- Confirm by pushing ENTER pushbutton SW5
- When pushing SW5, the red LED switches on for confirmation
- Exit setup configuration by moving switch SW3 to position 1 or proceed with the next parameter

6.2.4 Open Limit Configuration by Position

- Move switch SW4 to position 3
- Move switch SW6 to position 1
- Move switch SW3 in ON
- Confirm by pushing ENTER pushbutton SW5
- When pushing SW5, the red LED switches on for confirmation
- Exit setup configuration by moving switch SW3 to position 1 or proceed with the next parameter

6.2.5 Open Limit Configuration

- Move switch SW 3 to position ON
- Drive the actuator to open position using the handwheel.
- Move switch SW 4 to position 1
- Move switch SW 6 to position 0
- Confirm by pushing ENTER pushbutton SW5
- When pushing SW5, the red LED switches ON for confirmation
- Exit setup configuration by moving switch SW3 to position 1 or proceed with the next parameter

6.2.6 Close Limit Configuration by Torque

- Move switch SW4 to position 2
- Move switch SW6 to position 0
- Move switch SW3 to position ON
- Confirm by pushing ENTER pushbutton SW5 (red LED switch on)
- Operate the actuator to closing direction by local/remote control and wait until it stops by torque
- When the setting is complete, the red LED switches off
- Exit setup configuration by moving switch SW3 to position 1 or proceed with the next parameter

6.2.7 Open Limit Configuration by Torque

- Move switch SW4 to position 3
- Move switch SW6 to position 0
- Move switch SW3 to position ON
- Confirm by pushing ENTER pushbutton SW5 (red LED switch on)
- Operate the actuator to opening direction by local/remote control and wait until it stops by torque
- When the setting is complete, the red LED switches off
- Exit setup configuration by moving switch SW3 to position 1 or proceed with the next parameter

NOTE

During the new stroke limit setup, the minimum range between open and close limit position has to be at least within 45 degrees of the valve position; if the above condition is violated, the setup will not be successful and stroke limit error alarm will signal (shown by a red LED blinking). The red LED will continuously flash when the actuator is in setup functionality (dip switch SW3 in 'on' position) and rotary switches SW4 and SW6 are in one of the following positions:

- a. SW4=3 and SW6=0
(stroke limit of open configuration by torque)
- b. SW4=2 and SW6=0
(stroke limit of close configuration by torque)
- c. SW4=1 and SW6=0
(stroke limit of open configuration by position)
- d. SW4=0 and SW6=0
(stroke limit of close configuration by position)

The alarm is then reset by:

- a. Switching off and on the actuator
 - b. Performing a new, correct stroke limit setup in one of the 4 possible combinations.
-

 CAUTION

Actuator configuration must be conducted while the actuator is powered on. Do not touch any components not required for configuration to avoid injury or damage to equipment.

6.2.8 Stroking Time Selection in Closing

- Enter setup configuration: move switch SW3 to position ON (configuration function)
- Move switch SW4 to position 4
- Move switch SW6 to positions 4, 6, 8 for the requested stroking time according to the table below
- Push ENTER pushbutton SW5 to confirm
- When pushing SW5, the red LED switches on for confirmation
- The selected stroking time in closing is now set
- Exit setup configuration (move switch SW3 to position 1) or proceed to the next parameter

6.2.9 Stroking Time Selection in Opening

- Enter setup configuration: move switch SW3 to position ON (configuration function)
- Move switch SW4 to position 5
- Move switch SW6 to positions 4, 6, 8 for the requested stroking time according to the table below
- Push ENTER pushbutton SW5 to confirm
- When pushing SW5, the red LED switches on for confirmation
- The selected stroking time in opening is now set
- Exit setup configuration (move switch SW3 to position 1) or proceed to the next parameter

Table 6. Operating Times

Model	Nominal torque (Nm / lb.ft)	Operating time (secs 90°) at selected step		
		8	6	4
063/E006	63/46	15	28	48
125/E013	125/92	15	28	48
250/E025	250/184	15	28	48
500/E051	500/369	15	28	48
1000/E091	1000/738	24	45	80
2000/E171	2000/1475	53	100	180

NOTE: Time is guaranteed with +/- 10% tolerance on 90° stroke

6.2.10 Setting of the Torque-Limiting Device in Closing

Closing torque limits are 50%, 75% and 100% of the nominal torque. The nominal torque corresponding to 100% is set in-house and is stated on the nameplate.

- Enter setup configuration: move switch SW3 to position ON (configuration function)
- Move switch SW4 to position 6
- Move switch SW6 to positions 2, 5 or 9 for the requested torque value (in percentage) in closing
- Push ENTER pushbutton SW5 to confirm
- When pushing SW5, the red LED switches on for confirmation
- The setting of the torque limiting device in closing stroke is now complete
- Exit setup configuration (move switch SW3 to position 1) or proceed to the next parameter

NOTICE

Consult the valve manufacturer torque specifications for correct limit torque configuration.

WARNING

Installation, configuration, commissioning, maintenance, and repairs must be performed by approved and qualified personnel only.

6.2.11 Configuration of the Torque Limiting Device in Opening

Opening torque limits are 50%, 75% and 100% of the nominal torque. The nominal torque corresponding to 100% is set in-house and is stated on the nameplate.

- Enter setup configuration: move switch SW3 to position ON (configuration function)
- Move SW4 switch to position 7
- Move switch SW6 to positions 2,5 or 9 for the requested torque value (in percentage) in opening
- Push ENTER pushbutton SW5 to confirm
- When pushing SW5, the red LED switches on for confirmation
- The setting of the torque limiting device in opening is now complete
- Exit setup configuration (move switch SW3 to position 1) or proceed to the next parameter

NOTICE

Consult the valve manufacturer torque specifications for correct limit torque configuration.

WARNING

Installation, configuration, commissioning, maintenance, and repairs must be performed by approved and qualified personnel only.

6.2.12 Reverse Mode Configuration

- Enter setup configuration: move switch SW3 to position ON (configuration function)
- Move switch SW4 to position 8
- Move switch SW6 to position:
 - 1 counter-clockwise (CCW) ON
 - 0 counter-clockwise (CCW) OFF
- Push ENTER pushbutton SW5 to confirm
- When pushing SW5, the red LED switches on for confirmation
- Reverse mode (CCW) set is now completed
- Exit setup configuration (move switch SW3 to position 1) or proceed to the next parameter

6.2.13 Actuator Model Selection

The frames relevant to models 63/125 and 250/500 can be set to operate with a 63 Nm or 125 Nm motor and a 250 Nm or 500 Nm motor respectively. The difference is based on the technical characteristics of the electric motor itself.

Actuator model 63

- Enter setup configuration: move switch SW3 to position ON (configuration function)
- Move switch SW4 to position 9
- Move switch SW6 to position 0
- Confirm by pushing ENTER pushbutton, SW5
- When pushing SW5, the red LED switches on for confirmation
- Exit setup configuration (move switch SW3 to position 1) or proceed to the next parameter

Actuator model 125

- Enter setup configuration: move switch SW3 to position ON (configuration function)
- Move switch SW4 to position 9
- Move switch SW6 to position 1
- Confirm by pushing ENTER pushbutton SW5
- When pushing SW5, the red LED switches on for confirmation
- Exit setup configuration (move switch SW3 to position 1) or proceed to the next parameter

Actuator model 250

- Enter setup configuration: move switch SW3 to position ON (configuration function)
- Move switch SW4 to position 9
- Move switch SW6 to position 0
- Confirm by pushing ENTER pushbutton SW5
- When pushing SW5, the red LED switches on for confirmation
- Exit setup configuration (move switch SW3 to position 1) or proceed to the next parameter

Actuator model 500

- Enter setup configuration: move switch SW3 to position ON (configuration function)
- Move switch SW4 to position 9
- Move switch SW6 to position 1
- Confirm by pushing ENTER pushbutton SW5
- When pushing SW5, the red LED switches on for confirmation
- Exit setup configuration (move switch SW3 to position 1) or proceed to the next parameter

Actuator model 1000

- Enter setup configuration: move switch SW3 to position ON (configuration function)
- Move switch SW4 to position 9
- Move switch SW6 to position 3
- Confirm by pushing ENTER pushbutton SW5
- When pushing SW5, the red LED switches on for confirmation
- Exit setup configuration (move switch SW3 to position 1) or proceed to the next parameter

Actuator model 2000

- Enter setup configuration: move switch SW3 to position ON (configuration function)
- Move switch SW4 to position 9
- Move switch SW6 to position 4
- Confirm by pushing ENTER pushbutton SW5
- When pushing SW5, the red LED switches on for confirmation
- Exit setup configuration (move switch SW3 to position 1) or proceed to the next parameter

6.2.14 Blinker / Local Selector Configuration

The default configuration for Blinker / Local Selector relay is off (always Open). In Blinker configuration the relay changes its status every 500msec (Motor Running function) as the actuator is moving. In Local Selector configuration (with Local Interface OM3 installed), the relay is CLOSED when OM3 switch is on REMOTE and the relay is OPEN when OM3 switch is on LOCAL.

To configure Blinker or Local Selector monitoring function (when OM3 is present):

- Enter setup configuration: move switch SW3 to position ON (configuration function)
- Move switch SW4 to position 4
- Move switch SW6 to position 1 (Blinker) or 2 (Local Selector)
- Confirm by pushing ENTER pushbutton SW5
- When pushing SW5, the red LED switches on for confirmation
- Exit setup configuration (move switch SW3 to position 1) or proceed to the next parameter

6.2.15 Three-Wires (3-Wires) / Two-Wires (2-Wires) Remote Control Configuration

The SCE300 default remote control configuration is a Three-Wires (3-Wires) Remote Control

3-Wires configuration operation

- Command on terminal 35 to OPEN,
- Command on terminal 36 to CLOSE

2-Wires configuration operation

- Command present on terminal 35 to OPEN,
- Command absent on terminal 35 to CLOSE;
- Terminal 36 not used

To configure Remote Control parameter:

- Enter set up configuration: move switch SW3 to position ON (configuration function)
- Move switch SW4 to position 9
- Move switch SW6 to position 5 (3-WIRES) or 6 (2-WIRES)
- Confirm by pushing ENTER pushbutton SW5
- When pushing SW5, the red LED switches on for confirmation
- Exit set up configuration (move switch SW3 to position 1) or proceed with the next parameter

6.3 Configuration of the SCE300 via PDA / PC and 'A Manager' Software

If one of the optional modules OM1, OM9, or OM11 is installed on the SCE300 and this card features a Bluetooth interface, the actuator configuration can be performed by means of the 'A Manager' software installed on the PDA or PC.

Only the Blinker / Local Selector relay and heater cannot be configured via the 'A Manager' software. The relevant Instruction and Operating Manual comes with the 'A Manager' software.

CAUTION

Emerson will not be held responsible - directly or indirectly - for any damage or injuries caused by the misuse of external devices used for control or configuration of the actuator.

6.4 Hardware Configuration for Monitor Relay

The Monitor Relay indicates the following potential issues:

- Loss of power
- Stop by Torque out of limits
- Direction failure
- High Temperature
- Position sensor failure
- Local control panel with selector in local position
- Jammed Valve
- Hardware malfunction
- Alarm on the local control panel (if present)
- Stroke failure
- Missing input 4-20 mA (if OM1 optional module present)
- AManager local control (if Bluetooth is present)

Ensure that the power supply is off before attempting to configure the Monitor Relay.

The Monitor Relay contacts can be set as CLOSED or OPEN by changing the soldering of JUMPER J31 on logic board. By default pins 2 and 3 are soldered together, and the Monitor Relay contact operates as follows:

- contact CLOSED in normal condition while the relay is energized, and OPEN in case of malfunction (relay is de-energized).

By special request: if a contact must be OPEN under normal conditions and CLOSED when a malfunction occurs, contact JUMPER J31 must be modified by soldering pins 1 and 2 together.

WARNING

Before performing service or maintenance operations (unless otherwise indicated), ensure that power is turned off to the unit to avoid injury or damage to equipment.

Section 7: Maintenance and Troubleshooting

7.1 Maintenance

7.1.1 Routine Maintenance (approximately every two years)

Under normal operating conditions, the SCE300 actuator does not require maintenance; however, visual inspection for grease leakage or external visible damage is recommended every two years. In severe conditions (e.g. frequent operation, high temperatures), replace all seals that are allowing or may allow leakage of grease or infiltration of water.

WARNING

Before performing service or maintenance operations (unless otherwise indicated), ensure that power is turned off to the unit to avoid injury or damage to equipment.

The following checks are required for optimal actuator performance:

- Make sure that no grease is leaking from the actuator housing
- Check the external parts for possible damage and replace them immediately. If window glass is broken, the complete cover must be replaced (see Section 8 for individual item numbers)
- Repaint all areas where paint is missing. In chemically aggressive or saline environments, remove rust from surfaces and apply a rust preventative
- Check that all nuts and bolts securing the actuator to the valve are tight. If necessary, re-tighten these fasteners with a torque wrench
- For severe applications or if actuator operation is infrequent, perform maintenance checks on a more frequent basis than is stipulated by this document

7.1.2 Special Maintenance

In case of actuator failure, refer to Section 7.2 for possible causes. Spare parts can be ordered from Emerson; refer to the individual item number shown in Section 8.

The actuator must be disassembled if grease is leaking past the seals, malfunction of mechanical and/or electronic components is evident, or if scheduled preventative maintenance is to occur. Refer to the parts lists and exploded view drawings in Section 9 to determine what replacement components to order.

It is essential that every component ordered from Emerson references both the serial number of the actuator and the item number of the required component.

Special maintenance is recommended should the actuator generate excessive noise during operation.

NOTICE

After maintenance work has been performed, stroke the actuator multiple times to verify that the actuator is functioning correctly and no grease is leaking past the seals.

7.2 Troubleshooting

Every SCE300 actuator passes an outgoing functional test in the factory, performed by Emerson Quality Assurance personnel.

If the actuator does not work, prior to troubleshooting ensure that:

- The main supply is the same as stated in the nameplate menu
- The green LED for available power supply is switched on
- Power supply is available to the actuator and no protective device has de-clutched in the plant
- Check the position of the dip switch SW3: it must be '1'

7.2.1 The Electronics do not Switch on when Powered

- Check that the value of the main voltage on terminals L1 and L2 (and in the same case L3) is correct
- Remove the cover assembly
- Check the continuity of the wires between terminals L1, L2, L3 and the connector of the power card
- If there is no continuity on the L1-L2-L3 cables, replace the terminal board
- If continuity on the L1, L2, L3 cables checks out OK, replace the entire drive and control unit

7.2.2 24 V DC Output Voltage not Available at the Terminals

- Switch the main power supply off and disconnect all wires from terminals 33 and 34
- Switch the main power supply on and check if the voltage on terminals 33 and 34 is between 22 and 26 V DC
- If the voltage is correct, check the external wiring and the electrical load. It should not exceed 4 W
- If the voltage is not correct, replace the entire drive and control unit

7.2.3 The Actuator does not Work from Remote Controls

Check that:

- The wiring to terminals 32, 35 and 36 is correct
- There is no short circuit between wires
- The electrical load does not exceed 4 W
- If external voltage is used, the value has to be in the 24-120 V AC/DC range

7.2.4 The motor is Very Hot and does not Start

- Wait until the motor cools down before trying to operate the actuator again
- Check that the number of operations per hour and their duration is suitable for the actuator service (refer to the nameplate)
- Check that the valve operating torque is within the range of the unit's designed operating torque
- Always check the causes of abnormal operation

7.2.5 The Motor Runs but the Actuator does not Move the Valve

- Verify that the drive insert correctly fits in the actuator base
- Verify that the drive insert has enough engagement with the valve stem
- Verify that the key correctly fits in bore/keyway applications
- Check that the valve works in manual operation. If not, it is necessary to check the manual control area as follows:
 - Loosen the handwheel security dowel
 - Remove the handwheel
 - Check the integrity of the internal parts
 - When proceeding with assembly, follow the reverse order of the disassembly
 - Make sure there are no foreign bodies present. Take care not to damage the O-ring seals or gaskets.

7.2.6 The Valve does not Seat Correctly

- If the valve is stopped by torque in closing, increase the actuator output torque limit
- If the valve is stopped by position in closing, check that the valve reaches its seat position and then re-adjust the setting of the position limit
- The internal trim of the valve may be damaged

7.2.7 Excessive Torque for Valve Operation

- Clean, lubricate, and check the valve stem
- If the valve packing is too tight, loosen the gland bolt nuts
- Check that the internal valve trim or the reducer gears are well lubricated and not damaged

7.2.8 The Actuator does not Stop in Fully Open or Fully Closed Position

- Check that the actual open and closed positions of the valve respectively correspond to 100% and 0%
- Make sure that the torque and travel limits are correctly set (see Section 6)

7.2.9 Diagnostic LED

For more detailed alarms, check the diagnostic LED status (on the logic board). Diagnostic codes are shown in the below table:

Table 7.

Number of blinks of the diagnostic LED	Description
1x	Actuator in intermediate position (NO ALARM)
2x	Actuator on CLOSE limit (NO ALARM)
3x	Actuator on OPEN limit (NO ALARM)
4x	Under-voltage warning on Internal secondary voltage
5x	Position Sensor alarm (no SPI communication)
6x	High temperature alarm
7x	Bad CRC, OM1 communication error alarm
8x	Motor over-current alarm
9x	Stroke limit alarm
10x	Jammed Valve alarm
11x	High torque alarm

If a Sensor Alarm (5x blinks of the diagnostic LED) is observed:

- Check that the position sensor cable is connected.
- Check that the position sensor enclosure is not mechanically damaged. If it is broken, replace the entire electronic group.

If a bad CRC, OM1 communication error Alarm (7x blinks of the diagnostic LED) is observed:

- Restart the power supply: turn off and then turn on the actuator.

Section 8: Decommissioning

8.1 Disposal and Recycling

Once the SCE300 actuator reaches the end of its service life, the device must be disassembled. Do not dispose of non-biodegradable products, lubricants, and non-ferrous materials (e.g. rubber, PVC, resins) by simply dumping them into the environment; rather, dispose of such materials as indicated by the following table:

Table 8.

Subject	Hazardous	Recyclable	Disposal
Electrical and electronic equipment	Yes	Yes	Use specialist recyclers
Glass	No	Yes	Use specialist recyclers
Metals	No	Yes	Use licensed recyclers
Plastics	No	Yes	Use specialist recyclers
Rubber (seals and O-rings)	Yes	No	Will require special treatment before disposal; use specialist waste disposal companies
Oil and grease	Yes	Yes	Will require special treatment before disposal; use specialist recyclers or waste disposal companies
Batteries	Yes	Yes	Will require special treatment before disposal; use specialist recyclers or waste disposal companies

NOTICE

Do not re-use parts or components that have been declared unsuitable for use by qualified personnel.

NOTE

Check with local regulatory authorities before disposing of any components.

Section 9: Parts List and Drawings

This section includes the drawings and parts list of each component and subassembly of the SCE300 actuator.

- When ordering spare parts, be sure to include the serial number embossed on the actuator nameplate.
- When ordering spare parts, be sure to refer to the marked part list items on the attached drawings.
- Recommended spares for routine maintenance are marked with an asterisk [*] on the parts list.

In addition to checks performed before installation: if any screws or bolts require replacement, ensure that the replacement fasteners are of the recommended class and grade and are tightened to the specified torque.

Refer to the Section 9 for the correct bolt sizes used in the different models of SCE300 actuators and Specification TN1139 to determine the maximum torque to be applied to the bolts.

Table 9. Torque Requirements Guide

Model	Base bolts Torque requirements			Cover assembly bolts Torque requirements			Terminal block cover bolts torque requirements		
	Bolt Size	Bolt Material	MAX Tightening TORQUE (Nm / lb.in)	Bolt Size	Bolt Material	MAX Tightening TORQUE (Nm / lb.in)	Bolt Size	Bolt Material	MAX Tightening TORQUE (Nm / lb.in)
006	M8	A4/70	13 / 115	M6	A4/80	7 / 61	M6	A4/70	5 / 44
013	M8	A4/70	13 / 115	M6	A4/80	7 / 61	M6	A4/70	5 / 44
025	M10	A4/70	25 / 221	M6	A4/80	7 / 61	M6	A4/70	5 / 44
051	M10	A4/70	25 / 221	M6	A4/80	7 / 61	M6	A4/70	5 / 44
091	M12	A4/70	43 / 380	M6	A4/80	7 / 61	M6	A4/70	5 / 44
171	M12	A4/70	43 / 380	M6	A4/80	7 / 61	M6	A4/70	5 / 44

Model	Control Module bolts Torque requirements			Worm shaft flange bolts Torque requirements		
	Bolt Size	Bolt Material	MAX Tightening Torque (Nm / lb.in)	Bolt Size	Bolt Material	MAX Tightening Torque (Nm / lb.in)
006	M6	A4/70	5 / 44	M6	A4/70	5 / 44
013	M6	A4/70	5 / 44	M6	A4/70	5 / 44
025	M6	A4/70	5 / 44	M6	A4/70	5 / 44
051	M6	A4/70	5 / 44	M6	A4/70	5 / 44
091	M6	A4/70	5 / 44	M8	A4/70	13/115
171	M6	A4/70	5 / 44	M8	A4/70	13/115

Table 10. SCE300 Model 063 - General Assembly

Pos.	Description	Quantity
1	Nut UNI 5588-M6	2
2	Nut UNI 5588-M8	2
3	Eccentric	1
4	Planocentric gear	2
5	Spacer	1
6	Ball bearing type 16002	1
7	Ball bearing type 16004	2
8	Ball bearing type 6001	1
9	ESH screw UNI 5931-M6x8	1
10	HSHC screw UNI 5931-M6x16	4
11	HSHC screw UNI 5931-M4x14	7
12	HSHC screw UNI 5931-M6x18	2
13	HSHC screw UNI 5931-M6x25	4
14	HSHC screw UNI 5931-M8x20	4
15	HSSC screw UNI 5933-M4x10	1
16	Cover assembly	1
17	Drive and control unit	1
18	Handwheel	1
19	Output drive assembly	1
20	Standard housing	1
21	Stopper	2
22	Terminal block	1
23	Worm shaft flange	1
24	Anti-loosening washer UNI 8842-J6	1
25	Base plate ISO 5211 / F05-F07	1
26	Cover gasket	1*
27	Dowel pin UNI EN 22338	1
28	Earth stud	1
29	Fixed anulus	1
30	Gasket	1*
31	Indicator	1
32	Indicator shaft	1
33	Manual worm shaft	1
34	Motor pinion	1
35	O-ring Di=10.77/W=2.62	1*
36	O-ring Di=18.77/W=1.78	1*
37	O-ring Di=52.07/W=2.62	1*
38	O-ring Di=6.07/W=1.78	1*
39	Plug	1
40	Position label	1
41	Power clamps protection	1
42	Ring	2
43	Ring for pins alignment	1
44	Ring RW 7 UNI 7433	2
45	Seal washer 8.3	2
46	Sliding ring	1
47	Snap ring for shaft D.6	1
48	Terminal block cover	1
49	Terminal board gasket	1*
50	Wheel	1

* Indicates recommended spare parts

Figure 16

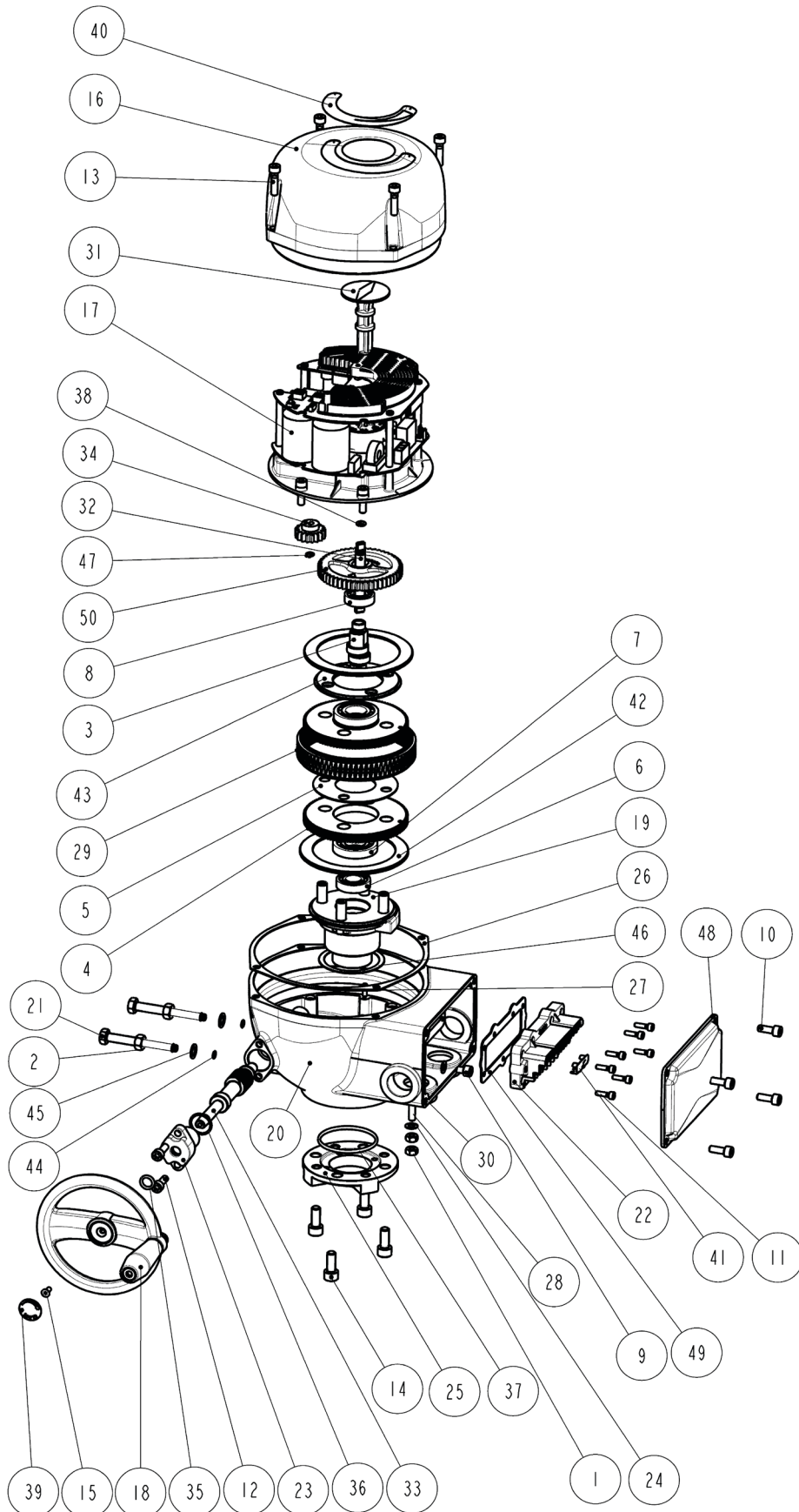

Table 11. SCE300 Model 125 - General Assembly

Pos.	Description	Quantity
1	Nut UNI 5588-M6	2
2	Nut UNI 5588-M8	2
3	Eccentric	1
4	Planocentric gear	2
5	Spacer	1
6	Ball bearing type 16002	1
7	Ball bearing type 16004	2
8	Ball bearing type 6001	1
9	ESH screw UNI 5931-M6x8	1
10	HSHC screw UNI 5931-M6x16	4
11	HSHC screw UNI 5931-M4x14	7
12	HSHC screw UNI 5931-M6x18	2
13	HSHC screw UNI 5931-M6x25	4
14	HSHC screw UNI 5931-M8x20	4
15	HSSC screw UNI 5933-M4x10	1
16	Cover assembly	1
17	Drive and control unit	1
18	Handwheel	1
19	Output drive assembly	1
20	Standard housing	1
21	Stopper	2
22	Terminal block	1
23	Worm shaft flange	1
24	Anti-loosening washer UNI 8842-J6	1
25	Base plate ISO 5211 / F07-F10	1
26	Cover gasket	1*
27	Dowel pin UNI EN 22338	1
28	Earth stud	1
29	Fixed anulus	1
30	Gasket	1*
31	Indicator	1
32	Indicator shaft	1
33	Manual worm shaft	1
34	Motor pinion	1
35	O-ring Di=10.77/W=2.62	1*
36	O-ring Di=18.77/W=1.78	1*
37	O-ring Di=52.07/W=2.62	1*
38	O-ring Di=6.07/W=1.78	1*
39	Plug	1
40	Position label	1
41	Power clamps protection	1
42	Ring	2
43	Ring for pins alignment	1
44	Ring RW 7 UNI 7433	2
45	Seal washer 8.3	2
46	Sliding ring	1
47	Snap ring for shaft D.6	1
48	Terminal block cover	1
49	Terminal board gasket	1*
50	Wheel	1

* Indicates recommended spare parts

Figure 17

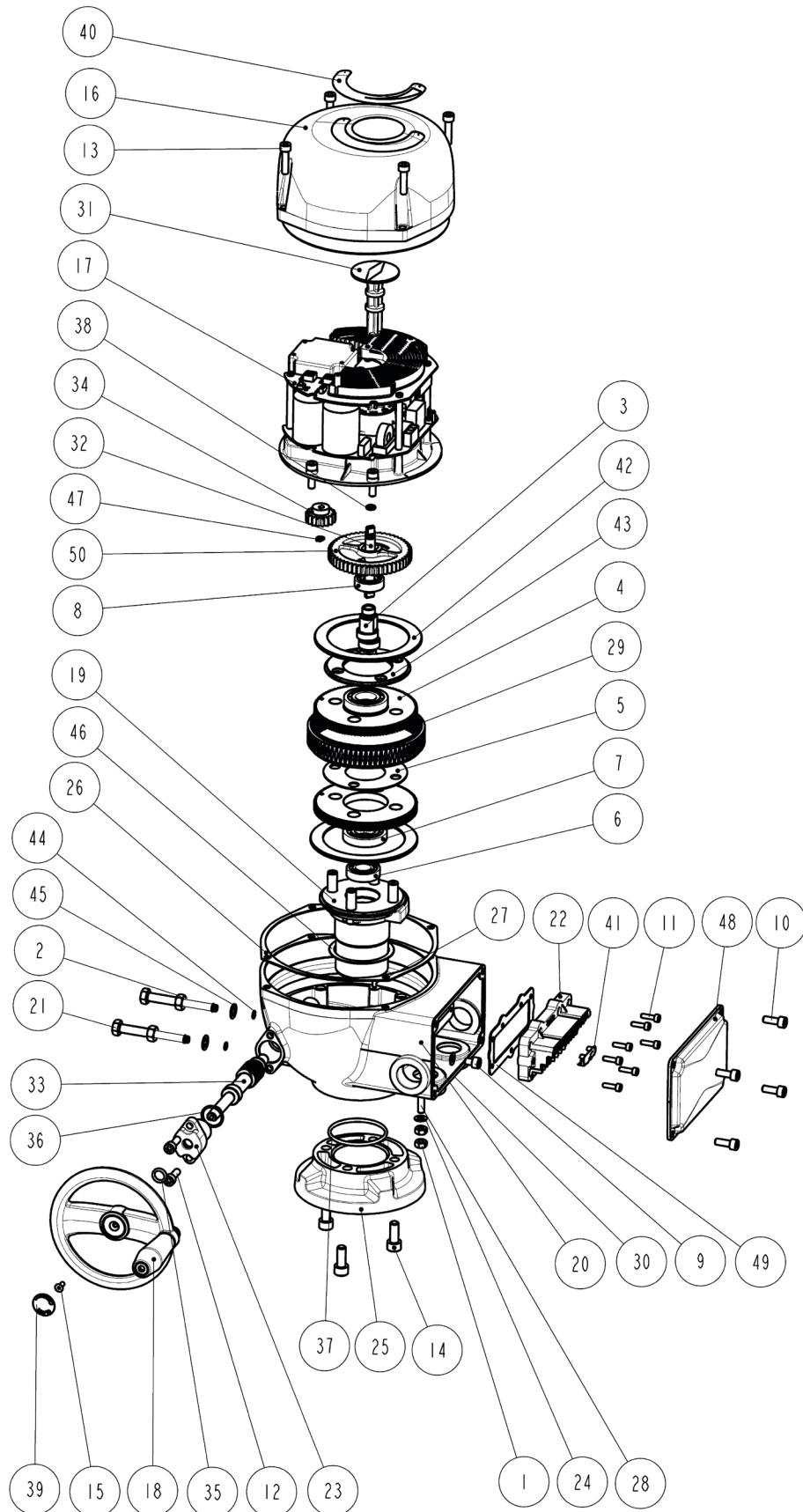

Table 12. SCE300 Model 250 - General Assembly

Pos.	Description	Quantity
1	Nut UNI 5588-M12	2
2	Nut UNI 5588-M6	2
3	Eccentric	1
4	Planocentric gear	2
5	Spacer	1
6	Ball bearing type 6005	2
7	Ball bearing type 6202	1
8	Ball bearing type 16002	1
9	ESH screw UNI 5931-M6x8	1
10	HSHC screw UNI 5931-M6x16	4
11	HSHC screw UNI 5931-M10x25	4
12	HSHC screw UNI 5931-M4x14	7
13	HSHC screw UNI 5931-M6x20	2
14	HSHC screw UNI 5931-M6x25	4
15	HSSC screw UNI 5933-M4x10	1
16	HSSC screw UNI 5933-M5x12	3
17	Cover assembly	1
18	Handwheel	1
19	Housing	1
20	Motor pinion	1
21	Output drive assembly	1
22	Stopper	2
23	Terminal block	1
24	Anti-loosening washer UNI 8842-J6	2
25	Base plate ISO 5211 F07-F10-F12	1
26	Cover gasket	1*
27	Dowel pin UNI EN 22338	1
28	Earth stud	1
29	Fixed anulus	1
30	Gasket	1*
31	Indicator	1
32	Indicator shaft	1
33	Manual worm shaft	1
34	O-ring Di=10.77/W=2.62	1*
35	O-ring Di=18.77/W=1.78	1*
36	O-ring Di=6.07/W=1.78	1*
37	O-ring Di=69.52/W=2.62	1*
38	Plug	1
39	Position label	1
40	Power clamps protection	1
41	Ring	1
42	Ring for pins alignment	1
43	Ring RW 10 UNI 7433	2
44	Seal washer 12.3	2
45	Sliding ring	1
46	Snap ring for shaft D.12	1
47	Terminal block cover	1
48	Terminal board gasket	1*
49	Wheel	1
50	Worm shaft flange	1
51	Drive and control assembly	1

* Indicates recommended spare parts

Figure 18

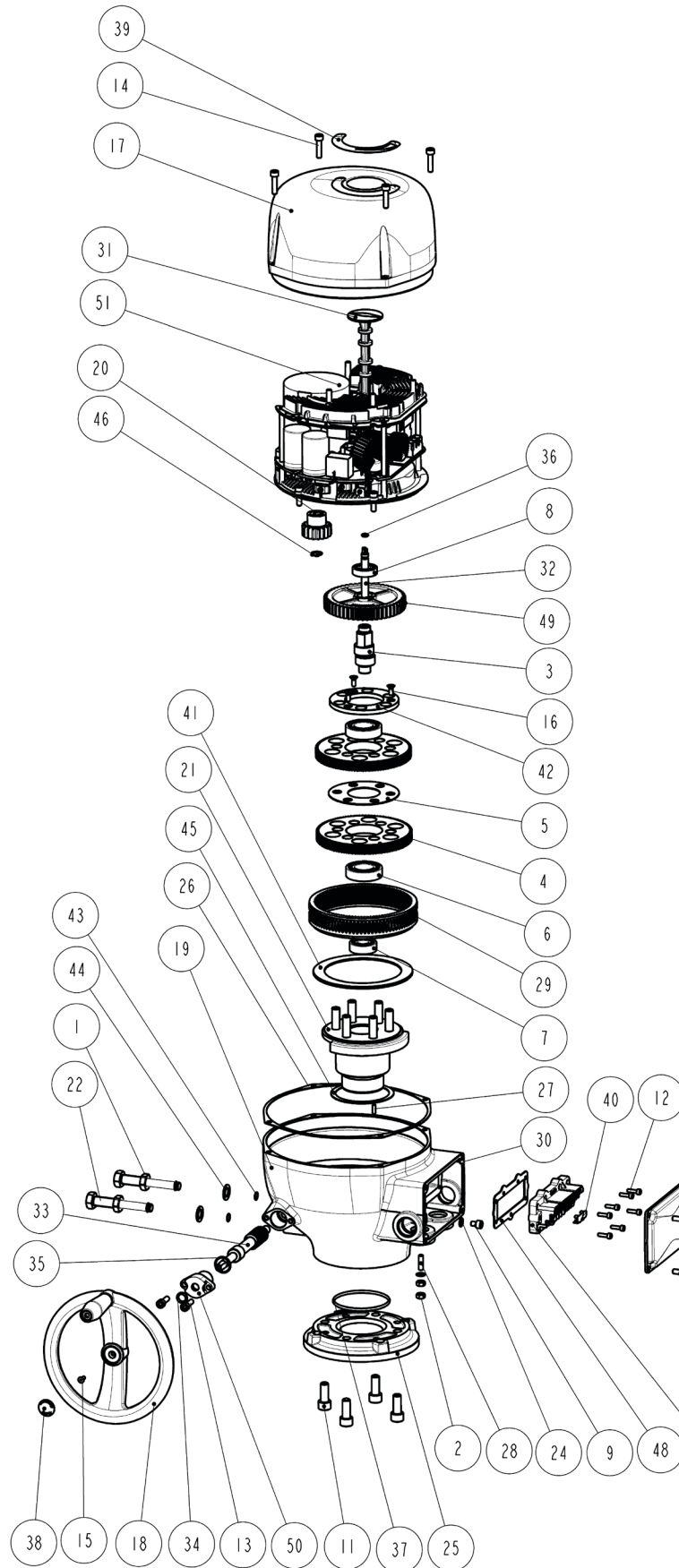

Table 13. SCE300 Model 500 - General Assembly

Pos.	Description	Quantity
1	Nut UNI 5588-M12	2
2	Nut UNI 5588-M6	2
3	Eccentric	1
4	Planocentric gear	2
5	Spacer	1
6	Ball bearing type 6005	2
7	Ball bearing type 6202	1
8	Ball bearing type 16002	1
9	ESH screw UNI 5931-M6x8	1
10	HSHC screw UNI 5931-M6x16	4
11	HSHC screw UNI 5931-M10x25	4
12	HSHC screw UNI 5931-M4x14	7
13	HSHC screw UNI 5931-M6x20	2
14	HSHC screw UNI 5931-M6x25	4
15	HSSC screw UNI 5933-M4x10	1
16	HSSC screw UNI 5933-M5x12	3
17	Cover assembly	1
18	Drive and control assembly	1
19	Handwheel	1
20	Housing	1
21	Motor pinion	1
22	Output drive assembly	1
23	Stopper	2
24	Terminal block	1
25	Anti-loosening washer UNI 8842-J6	2
26	Base plate ISO 5211 F10-F12	1
27	Cover gasket	1*
28	Dowel pin UNI EN 22338	1
29	Earth stud	1
30	Fixed anulus	1
31	Gasket	1*
32	Indicator	1
33	Indicator shaft	1
34	Manual worm shaft	1
35	O-ring Di=10.77/W=2.62	1*
36	O-ring Di=18.77/W=1.78	1*
37	O-ring Di=6.07/W=1.78	1*
38	O-ring Di=69.52/W=2.62	1*
39	Plug	1
40	Position label	1
41	Power clamps protection	1
42	Ring	1
43	Ring for pins alignment	1
44	Ring RW 10 UNI 7433	2
45	Seal washer 12.3	2
46	Sliding ring	1
47	Snap ring for shaft D.12	1
48	Terminal block cover	1
49	Terminal board gasket	1*
50	Wheel	1
51	Worm shaft flange	1

* Indicates recommended spare parts

Figure 19

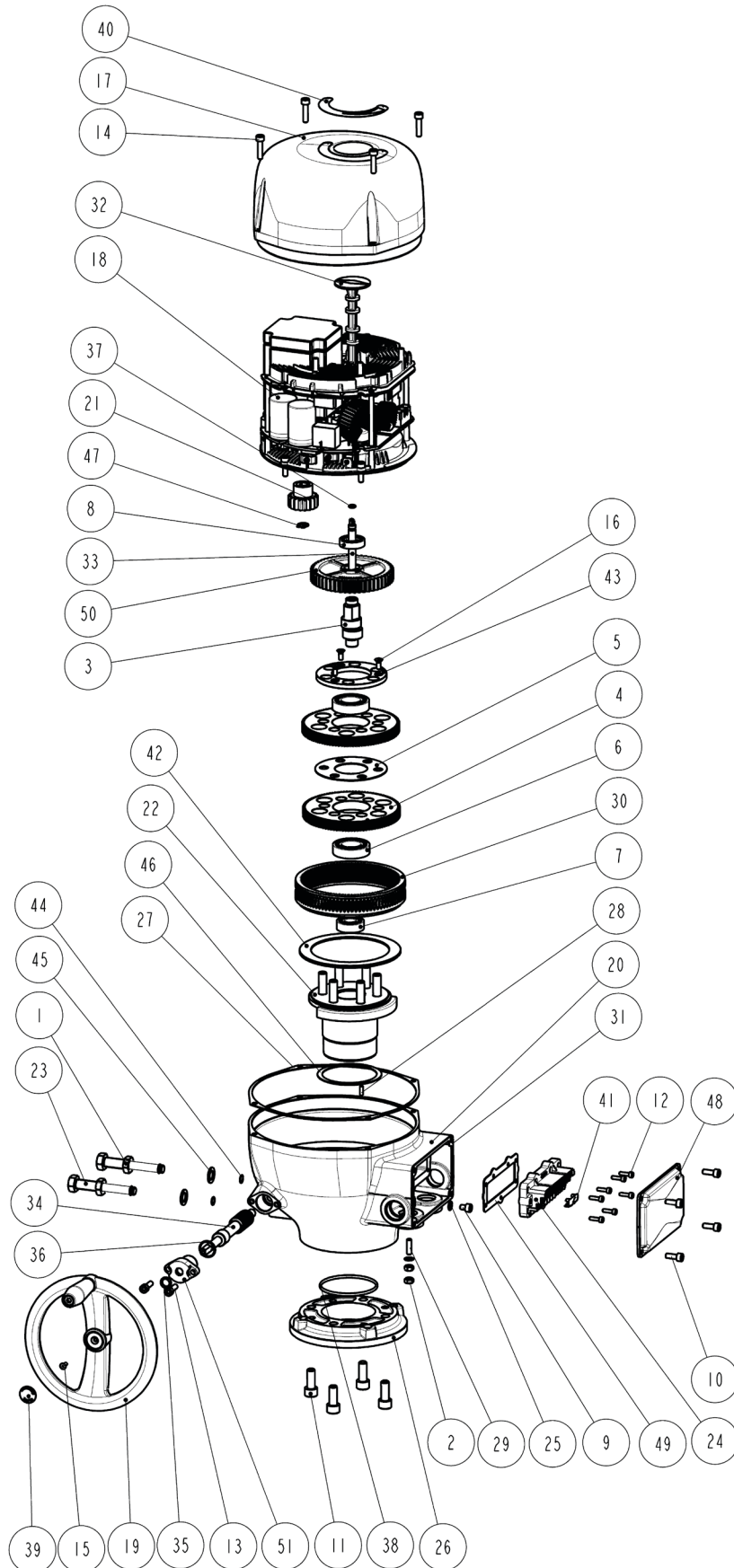

Table 14. SCE300 Model 1000 - General Assembly

Pos.	Description	Quantity
1	Nut UNI 5588-M16	2
2	Nut UNI 5588-M6	2
3	Eccentric	1
4	Planocentric gear	2
5	Spacer	1
6	Ball bearing type 6305	2
7	Ball bearing type 16002	1
8	Ball bearing type NJ202ECP	1
9	ESH screw UNI 5931-M6x8	1
10	HSHC screw UNI 5931-M12x65	4
11	HSHC screw UNI 5931-M4x14	7
12	HSHC screw UNI 5931-M6x25	4
13	HSHC screw UNI 5931-M8x25 A4-70	2
14	HSSC screw UNI 5933-M6x20	1
15	HSSC screw UNI 5933-M4x10	1
16	HSSC screw UNI 5933-M5x12	3
17	Cover assembly	1
18	Drive and control assembly	1
19	Handwheel assembly	1
20	Output drive assembly	1
21	Stopper	2
22	Terminal block	1
23	Terminal cover gasket	2*
24	Anti-loosening washer UNI 8842-J6	2
25	Base plate ISO 5211 F10-F14	1
26	Cover gasket	1*
27	Dowel pin UNI EN 22338	1
28	Earth stud	1
29	Fixed anulus	1
30	Housing	1
31	Indicator	1
32	Indicator shaft	1
33	Manual worm shaft	1
34	Motor pinion	1
35	O-ring Di=13.94/W=2.62	1*
36	O-ring Di=25.12/W=1.78	1*
37	O-ring Di=6.07/W=1.78	1*
38	O-ring Di=82.22/W=2.62	1*
39	Plug	1
40	Position label	1
41	Power clamps protection	1
42	Ring	1
43	Ring for pins alignment	1
44	Ring RW 14 UNI 7433	2
45	Seal washer 16.3	2
46	Sliding ring	2
47	Terminal board gasket	1*
48	Washer	1
49	Wheel	1
50	Worm shaft flange	1
51	Terminal block cover	1
52	HSHC screw UNI 5931-M6x18	4

* Indicates recommended spare parts

Figure 20

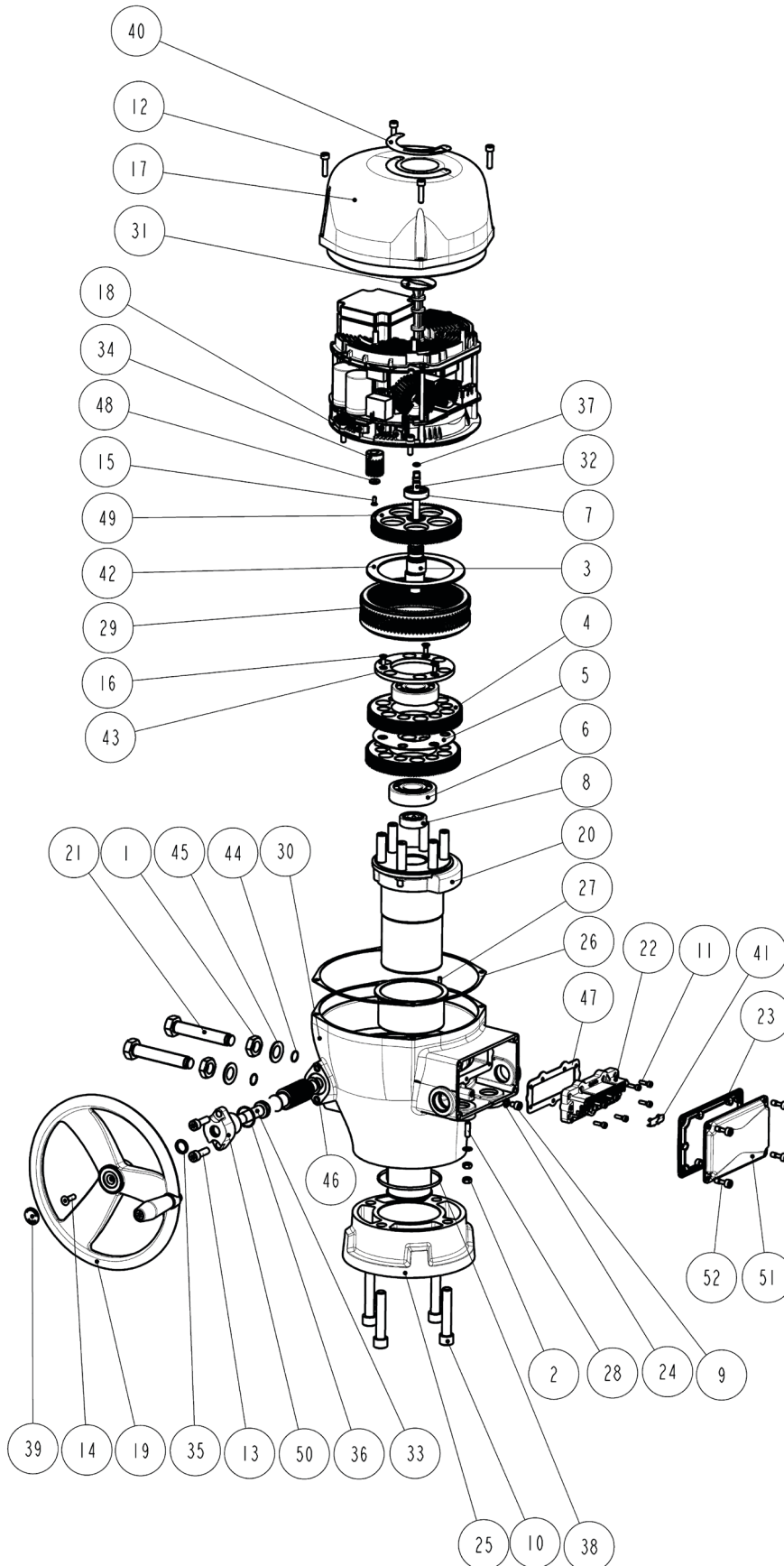

Table 15. SCE300 Model 2000 (Gear Reducer) - General Assembly

Pos.	Description	Quantity
1	Nut M20 ISO 4032 EN 24032	2
2	Ball bearing type 6006	1
3	Ball bearing type 16004	1
4	Ball bearing type 61908	1
5	HSHC screw UNI 5931-M6x16	3
6	HSHC screw UNI 5931-M12x30	4
7	HSHC screw UNI 5931-M12x65	4
8	HSHC screw UNI 5931-M8x25 A4-70	6
9	SCE300 actuator	1
10	Base housing	1
11	Base plate F12-F16 EN ISO 5211	1
12	Bearing support	1
13	Bushing	2
14	Bushing	1
15	Bushing	1
16	Bushing	1
17	Dowel pin UNI EN 22338 D.8x20 type B	4
18	Gasket	1*
19	Hex head screw UNI EN 24017-M20x80	2
20	Idle wheel shaft	1
21	Needle bearing type NKI 22/16	2
22	O-ring Di=82.22/W=2.62	1*
23	Position wheel	1
24	Seal washer 20.3	2
25	Sector gear	1
26	Sliding ring	1
27	Upper cover	1
28	Wheel	2

* Indicates recommended spare parts

Figure 21

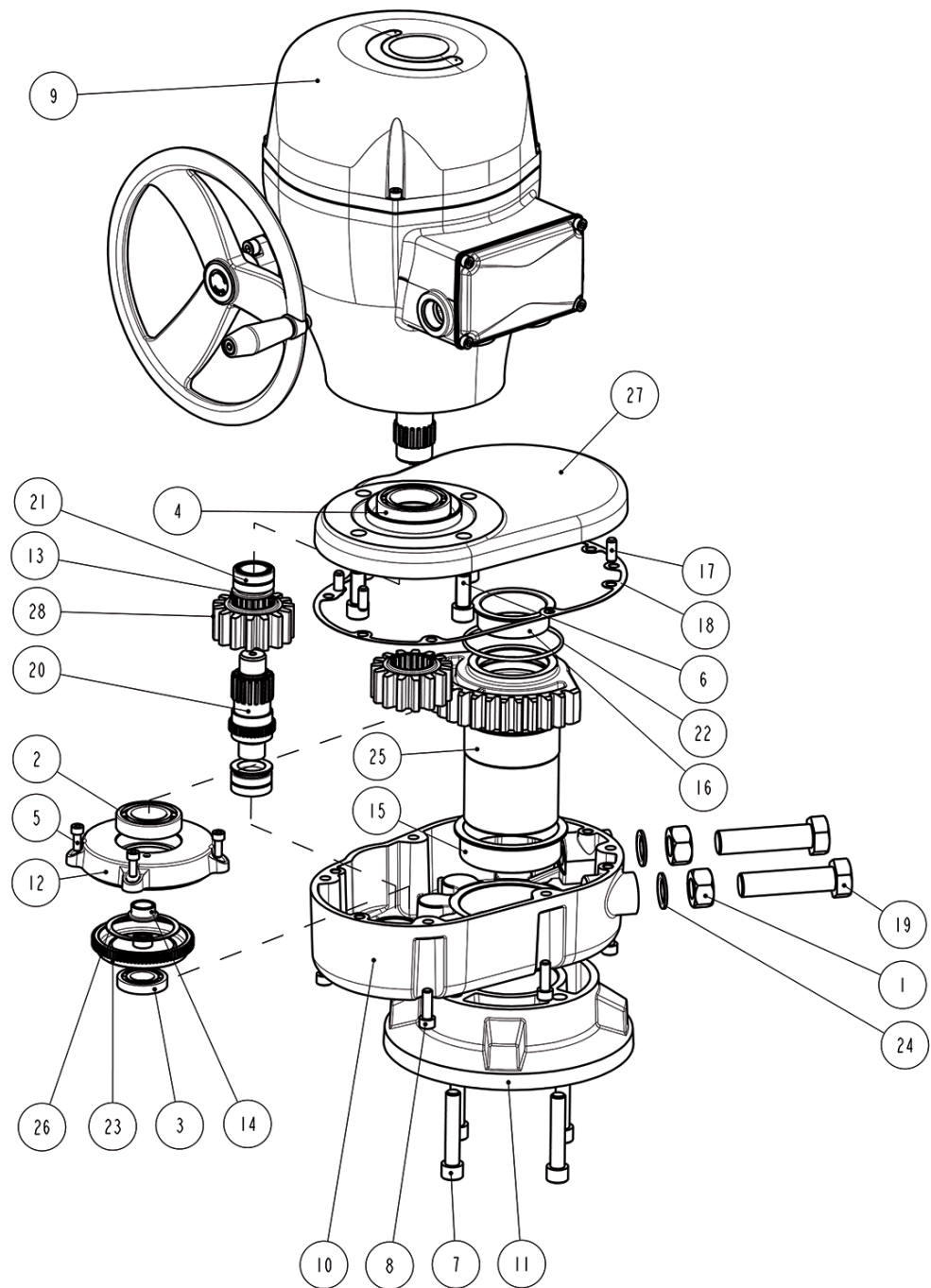
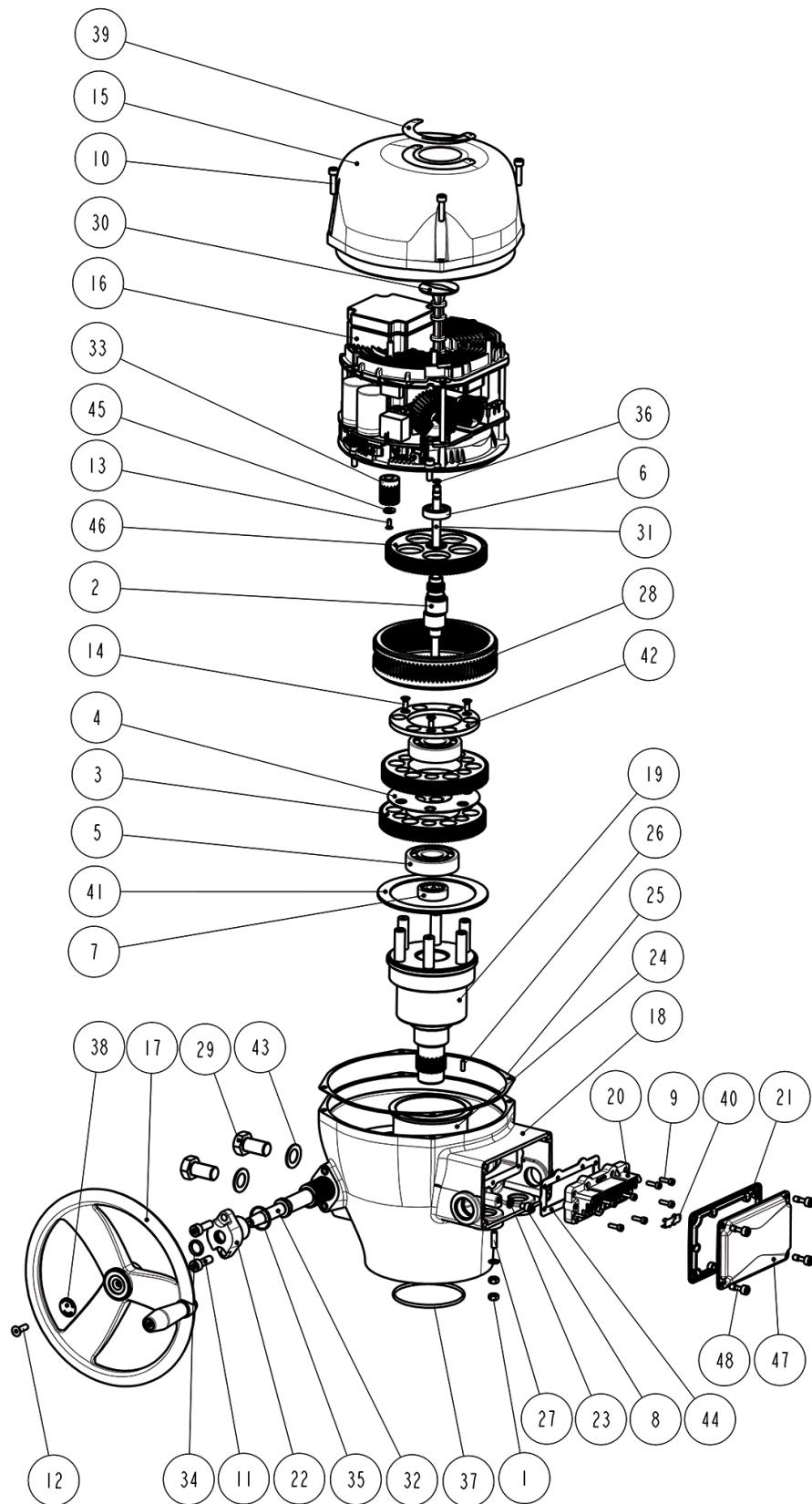

Table 16. SCE300 Model 2000 (Actuator) - General Assembly

Pos.	Description	Quantity
1	Nut UNI 5588-M6	2
2	Eccentric	1
3	Planocentric gear	2
4	Spacer	1
5	Ball bearing type 6305	2
6	Ball bearing type 16002	1
7	Roller bearing type NJ202ECP	1
8	ESH screw UNI 5931-M6x8	1
9	HSHC screw UNI 5931-M4x14	7
10	HSHC screw UNI 5931-M6x25	4
11	HSHC screw UNI 5931-M8x25 A4-70	2
12	HSSC screw UNI 5933-M6x20	1
13	HSSC screw UNI 5933-M4x10	1
14	HSSC screw UNI 5933-M5x12	3
15	Cover assembly	1
16	Drive and control assembly	1
17	Handwheel assembly	1
18	Housing	1
19	Output drive assembly	1
20	Terminal block	1
21	Terminal cover gasket	1*
22	Worm shaft flange	1
23	Anti-loosening washer UNI 8842-J6	2
24	Bushing	1
25	Cover gasket	1*
26	Dowel pin UNI EN 22338	1
27	Earth stud	1
28	Fixed anulus	1
29	Hex head screw UNI EN 24017-M16x30	2
30	Indicator	1
31	Indicator shaft	1
32	Manual worm shaft	1
33	Motor pinion	1
34	O-ring Di=13.94/W=2.62	1*
35	O-ring Di=25.12/W=1.78	1*
36	O-ring Di=6.07/W=1.78	1*
37	O-ring Di=82.22/W=2.62	1*
38	Plug	1
39	Position label	1
40	Power clamps protection	1
41	Ring	1
42	Ring for pins alignment	1
43	Seal washer 16.3	2
44	Terminal board gasket	1*
45	Washer	1
46	Wheel	1
47	Terminal block cover	1
48	HSHC screw UNI 5931-M6x18	4

* Indicates recommended spare parts

Figure 22



World Area Configuration Centers (WACC) offer sales support, service, inventory and commissioning to our global customers. Choose the WACC or sales office nearest you:

NORTH & SOUTH AMERICA

19200 Northwest Freeway
Houston TX 77065
USA
T +1 281 477 4100

Av. Hollingsworth
325 Iporanga Sorocaba
SP 18087-105
Brazil
T +55 15 3413 8888

ASIA PACIFIC

No. 9 Gul Road
#01-02 Singapore 629361
T +65 6777 8211

No. 1 Lai Yuan Road
Wuqing Development Area
Tianjin 301700
P. R. China
T +86 22 8212 3300

MIDDLE EAST & AFRICA

P. O. Box 17033
Jebel Ali Free Zone
Dubai
T +971 4 811 8100

P. O. Box 10305
Jubail 31961
Saudi Arabia
T +966 3 340 8650

24 Angus Crescent
Longmeadow Business Estate East
P.O. Box 6908 Greenstone
1616 Modderfontein Extension 5
South Africa
T +27 11 451 3700

EUROPE

Holland Fisor 6
Székesfehérvár 8000
Hungary
T +36 22 53 09 50

Strada Biffi 165
29017 Fiorenzuola d'Arda (PC)
Italy
T +39 0523 944 411

www.emerson.com/bettis

VCIOM-13933-EN ©2020 Emerson. All rights reserved.

The Emerson logo is a trademark and service mark of Emerson Electric Co. Bettis™ is a mark of one of the Emerson family of companies. All other marks are property of their respective owners.

The contents of this publication are presented for information purposes only, and while every effort has been made to ensure their accuracy, they are not to be construed as warranties or guarantees, express or implied, regarding the products or services described herein or their use or applicability. All sales are governed by our terms and conditions, which are available on request. We reserve the right to modify or improve the designs or specifications of our products at any time without notice.

BETTIS™

