

Service Manual
Version: SM 8000-1000-01 Ed 04
Release: February, 2017

Damcos™ Local Power Unit

Service Manual



The content of this publication are presented for information purposes only, and while effort has been made to ensure their accuracy, they are not to be construed as warranties or guarantees, expressed or implied, regarding the products or services described herein or their use or applicability. All sales are governed by our terms and conditions, which are available upon request. We reserve the right to modify or improve the designs or specifications of our products at any time without notice. Damcos A/S accepts no responsibility for any errors that may appear in this publication.

As each system may be configured for each delivery, the content and illustrations in this manual may differ from your system.

Table of Contents

Abbreviation and Denomination	7
Safety	9
Warning Levels Used in Manuals	10
General Service Instructions for LPU	13
General Considerations	14
LPU and Optional Equipment	16
LPU-S Overview	19
Overview LPU-S	20
LPU-S-Ex Overview	23
Overview LPU-S-Ex	24
LPU-S-Ex-ia Overview	27
Overview LPU-S-Ex-ia	28
LPU-D Overview	31
Overview LPU-D	32
LPU-D-Ex Overview	35
Overview LPU-D-Ex	36
LPU-D-Ex-ia Overview	39
Overview LPU-D-Ex-ia	40
Troubleshooting Guide LPU	43
Fault Finding List LPU	45
LPU-S frequently restarting in open position	47
Motor not running and is hot	49
Motor not running and is Cold	49
Motor not stopping	50
Pump rendering too low (or no) pressure in one or both directions	51
Solenoid valve not working	52
Actuator only running in one direction (the unit can either only open or only close)	53
Noise from pump, but only at low pressure	54

Noise from pump, but only at high pressure	55
Noise from pump at both high and low pressure.....	55
Motor running hot, LPU is operating normally	56
LPU-D not maintaining pressure on actuator	57
Spring actuator only partly closing or not starting to close	58
Emergency operation by key giving oil spillage through breather valve	59
Emergency operation by key not possible, hydraulically locked.....	59
Emergency operation by hand pump giving oil spillage through breather valve	59
Emergency operation by hand pump not possible	60
Pump not rendering sufficient oil at high pressure (“valve running too slowly”)	61
Pump not rendering sufficient oil at low pressure (“valve running too slowly”)	61
Motor running for a short time and stops	
High pressure on the port to which oil is led.....	62
Motor running for a short time and stops	62
Motor ”diving” in RPM in end position	63
Motor ”diving” in RPM as spring actuator opens	63
Oil spillage, generally	64
Oil in electronic connection box	64
Oil spillage from breather valve.....	64
Unit drawing too much current.....	65
Too little tank volume for operating actuator	66
LPU cannot raise pressure after hand pump operation (but no problems after remote operation)	67
LPU leaking from bleeder valve when hand pump is mounted	68
Spring actuator do not close by emergency hand pump operation.....	69
LPU-Ex motor do not run	70
LPU-Ex has to be bulkhead mounted because of too little space or zone 0 at ac- tuator	71
Position indicator errors	72
Operating LPU-S 2	73
Operating LPU-D 2a	75
Emergency Operation of LPU V.2	77
Speed adjustment for Actuator on LPU (v.2)	83
Pump pressure adjustment for LPU	85

Refill of Oil in LPU	87
Replace Pump in LPU	93
Replace DPCV in LPU	97
Replace release valve in LPU	99
Setup new P-net LPU circuit board	101
Setup new P-net LPU circuit board in VIEW ver. 3.16	103
Replace Printed Circuit Board	105
Replace Solenoid Valve in LPU-D	107
Replace pressure switch	109
LPU Technical Data	111
Technical Data.....	113
LPU Power Control System	119
LPU Power Control Description	121
Operation LPU-S	123
Operating LPU-D.....	124
LPU with LED Position Indicator	125
LPU P-NET System	129
LPU P-Net Description	131
PCB Diagram for Local Control	132
PCB Diagram for Stand Alone Unit.....	133
Hydraulic Hand Pump	135
Technical Data.....	137
Hydraulic Diagram for Direct Mounted LPU Handpump	138
Hydraulic Diagram for Bulkhead Mounted LPU Handpump	139
Index	141

Abbreviation and Denomination

DPCV	Double Pilot Operated Check Valve
HP	Hand Pump
ISC	Integrated Ship Control
LPU	Local Power Unit
LPU-D	LPU for double-acting actuator
LPU-S	LPU for single-acting spring operated actuator
LPU-Ex	LPU approved for mounting in hazardous area
PLC	Programmable Logic Controller
BB-VPI	Bulkhead mounted Valve Position Indicator
VPI	Valve Position Indicator

Safety

A description of issues concerning
personal safety when handling

Damcos™ VRC

Warning Levels Used in Manuals

The following warning levels are used in the documentation of Damcos A/S for the safety of people and equipment.



Warning! Indicates a potentially hazardous situation which, if not avoided, could result in death or serious injury.

Caution! Indicates a potentially hazardous situation which, if not avoided, may result in property damage.

Note! Indicates important information regarding the product.

Warnings

All personnel that handles Damcos LPU shall take part of and understand the following information prior to handling the system. See warnings on next page.



WARNING!

Failure to follow safe installation and service guidelines could result in death or serious injury.

Make sure only qualified personnel perform the installation or service.

Do not perform any service other than those contained in this manual unless you are qualified and authorized to do so.

Always observe local environmental, safety and health regulations.

Use only certified instruments and tools appropriate for the area classification.

Use the equipment only as specified in this manual. Failure to do so may impair the protection provided by the equipment.

Use only original spare parts from Marine Tank Management. Any replacement with non-recognized spare parts can jeopardize the intrinsic safety and the function of the product.

Always follow safety guidelines when handling heavy equipment. The weight of the equipment is noted on the drawings.



WARNING!

High voltage that may be present on leads could cause electrical shock.

Avoid contact with live leads and terminals.

Before disconnection of units in the hazardous area the wiring has to be disconnected in the safe area. Main power in the cabinets do not have to be turned off.

Disconnect power to any electrical unit you are to replace.

General Service Instructions for LPU

This Chapter Describes the General Requirements
and Service Recommendations for the LPU

General Considerations

Important notes on LPU equipment and systems:

- use original spare parts and tools
- use lifting facilities and transport equipment
- use handling instructions
- electrical cables are only to be connected by qualified personnel

Note! Read Safety chapter before handling any equipment!

Bleeder valve positions on LPU

It is extremely important that bleeder valve position is correctly chosen when mounting LPU with actuator on pipe. Other positions are plugged when not used! This is normally done at installation.

Note! The choice of bleeder valve position is always selected at the highest point on LPU or actuator tank!

For KC/KF/KFR bleed valve on top of actuator has no connection to LPU tank and must always be present!

See next page for illustrated examples.

LPU-D and LPU-S on KF/KFR - Bleed valve positions

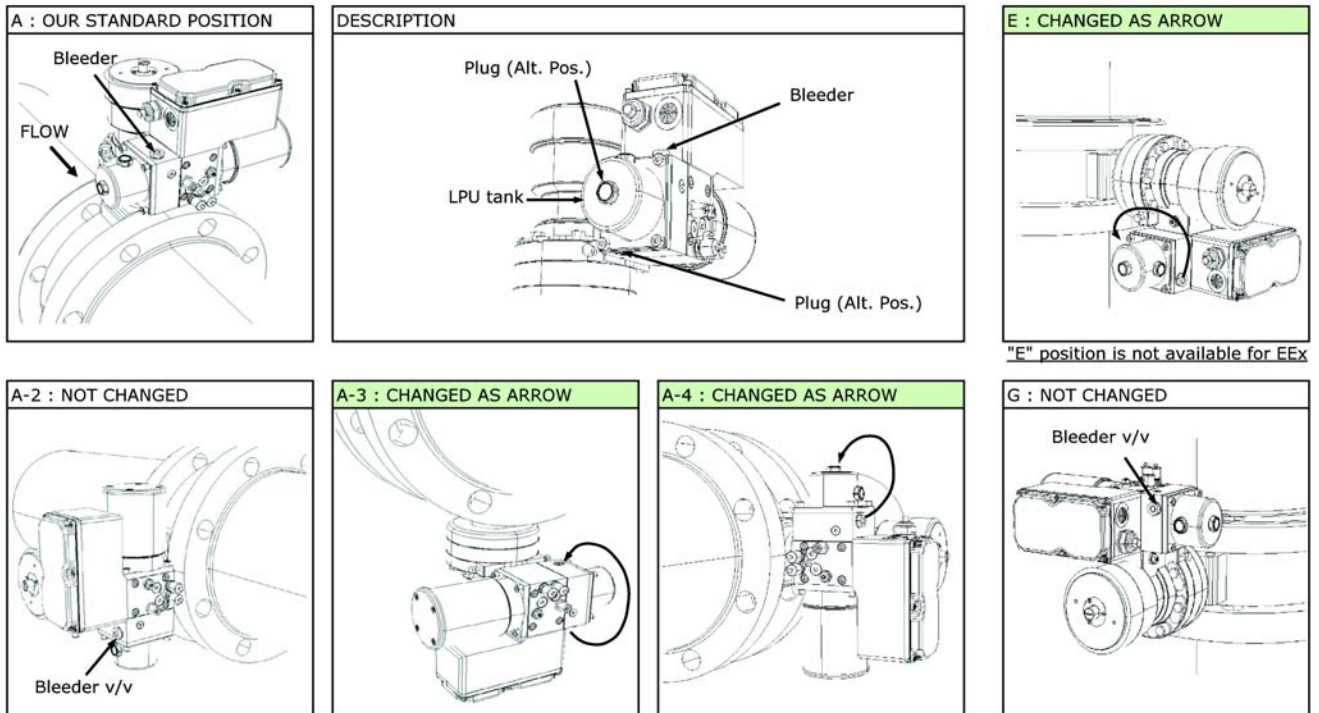

LPU-S on BRCF - Bleed valve positions

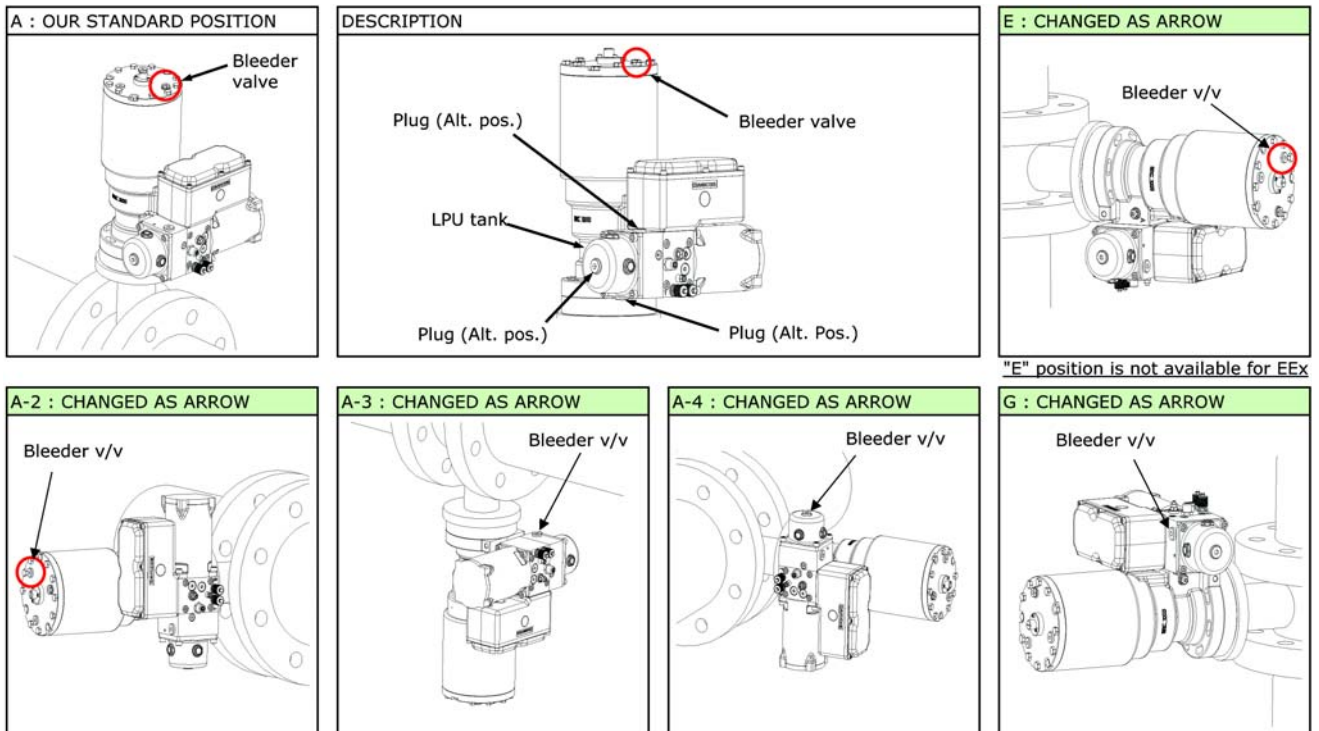

LPU and Optional Equipment

The LPU can be equipped with additional equipment, such as switches, indicators etc. Further more the LPU can be bulkhead mounted, mounted with blocks or otherwise mounted in respect to customer requirements and system. Always check your specific system drawings and documents for correct information. This manual is a guide on how to perform the service parts of your system. For further information please contact Emerson service engineer or appointed agent.

Description

The LPU offers installation in both safe and hazardous area in two basic versions:

- LPU-S (fail safe) for single acting actuator
- LPU-D (fail set) for double acting actuator

Depending on safety zone requirements the LPU's can be of Ex or Ex-ia, designed to meet the requirements for mounting in hazardous areas. Be sure to use the designated equipment and spare parts when performing service on your system.

The LPU system is designed to be controlled by two electrically different types of controls:

- Power controlled
- P-NET® bus controlled

The LPU can also be used as a stand-alone system.

LPU with an LED Position Indicator

LPU (except the Ex version) with an IP 68 LED indicator, showing clear RED or GREEN light when the valve is CLOSED respectively OPEN is available in Power controlled and P-NET controlled LPU systems. This may especially be useful if LPU is operated from a local hand pump, were the LPU is mounted in a distance so the indication of the actuator is not visible. The LED must be supplied with 24 VDC.

LPU Mounting

The LPU can be mounted in the following ways:

- Direct mounting on BRC 250 - 16000, BRCF 250 - 16000, KC 65 - 400 and KF 65-250.
- Mounting on BRC 052, 072 and 092 is via inter-mediate block and with external position indication cable.
- Mounting on BRCF Fail Open and KF Fail Open is via special intermediate block.
- Mounting on BRC 125 and BRCF 125 has to be bulkhead mounted or supported otherwise.
- LPU may be bulk-head mounted via a standard B-block. - It is possible to use a B-block with integrated VPI, (please see illustration). No external indication cable.

When decided on mounting method the pipe dimensions has to be considered as well.

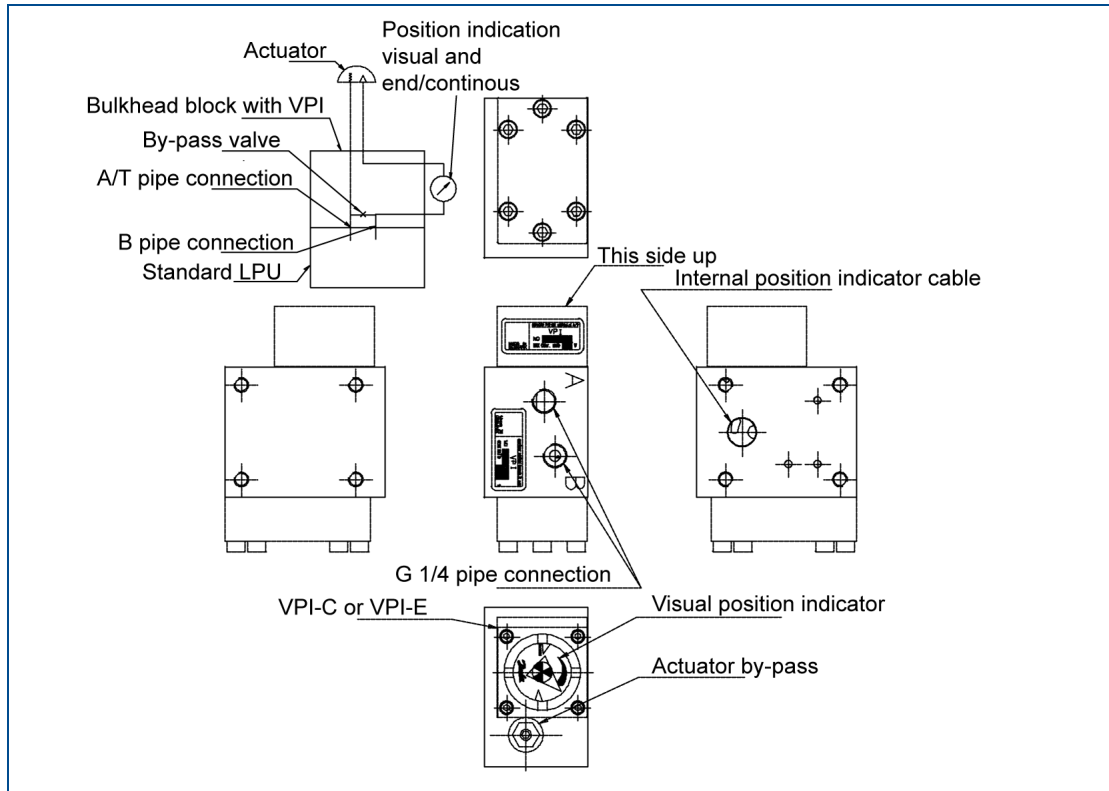

B-VPI Block for bulk-head mounted LPU.

Note! If bulk-head mounted:
Oil level must be checked before starting up the LPU.
LPU must be placed with motor pointing down and breather valve on top, short suction pipe recommend.
The LPU may be emergency operated as if mounted direct on actuator.
Properly de-airing via quick connections on the LPU.

LPU-S Overview

This Chapter Describes the LPU-S with
Overview and Handling Instructions

Overview LPU-S

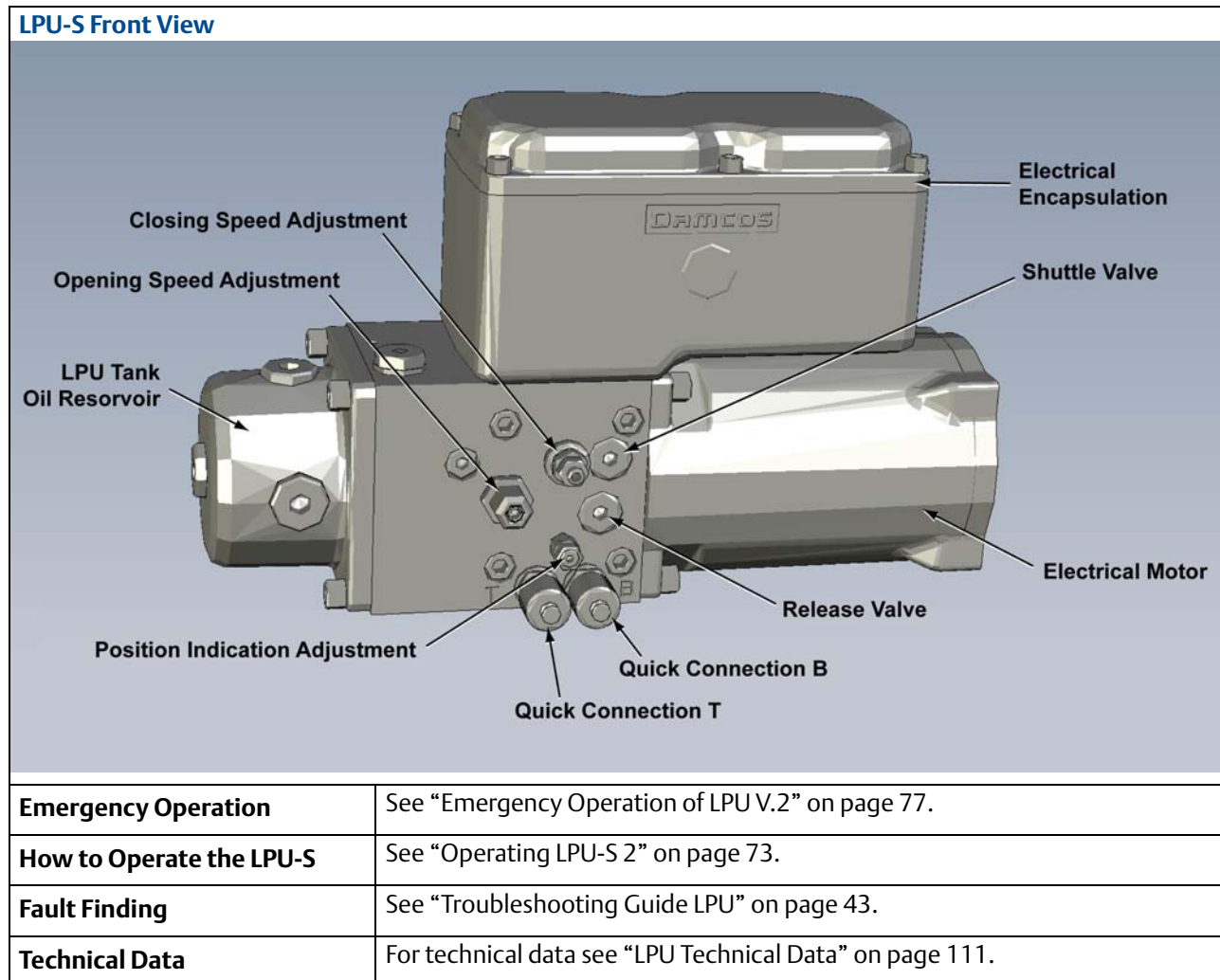

LPU-S Top View with top cover made partly transparent.

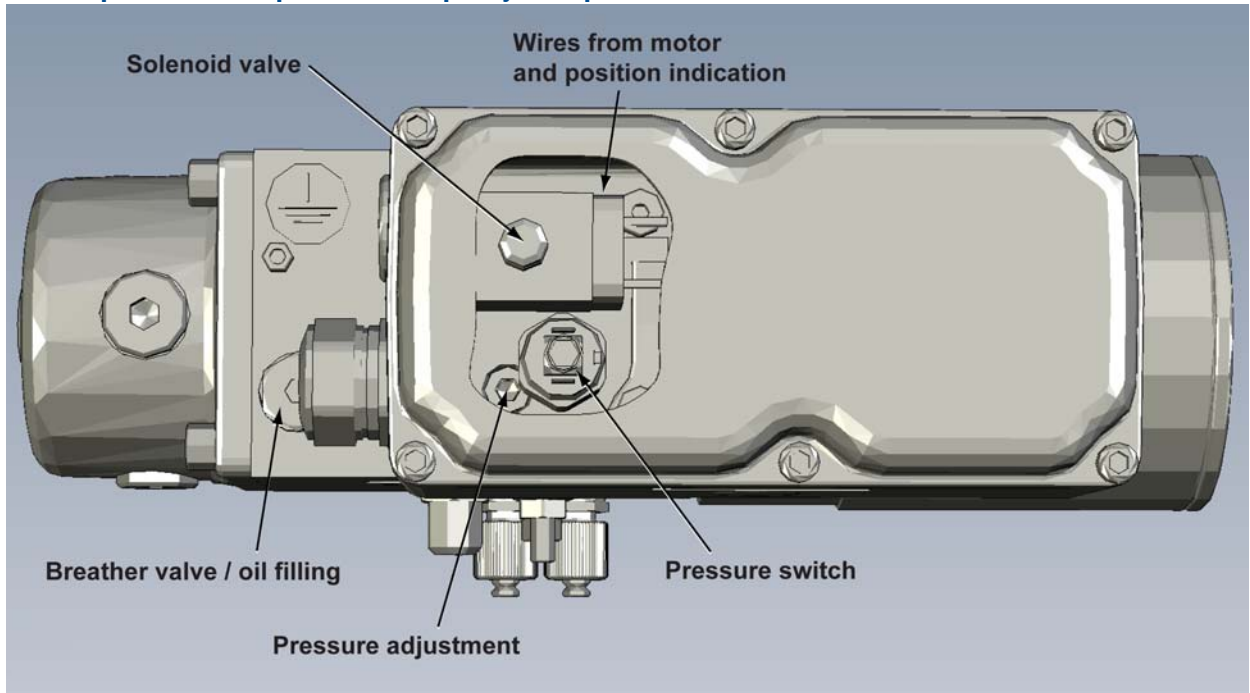

LPU-S Bottom View

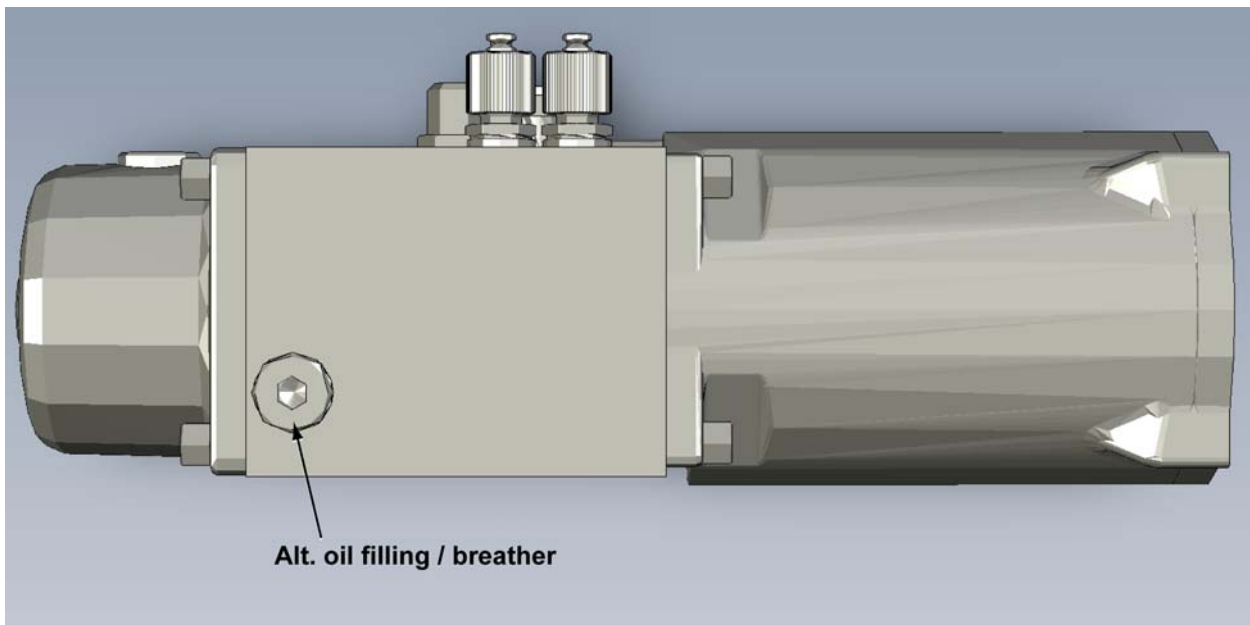

LPU-S-Ex Overview

This Chapter Describes the LPU-S-Ex with
Overview and Handling Instructions

Overview LPU-S-Ex

LPU-S Front View	
Emergency Operation	See “Emergency Operation of LPU V.2” on page 77.
How to Operate the LPU-S-Ex	See “Operating LPU-S 2” on page 73.
Fault Finding	See “Troubleshooting Guide LPU” on page 43.
Technical Data	For technical data see “LPU Technical Data” on page 111.
Cable Glands	See “Cable Gland” on page 116.
Cable	See “Cables” on page 116.

LPU-S Top View with top cover made partly transparent.

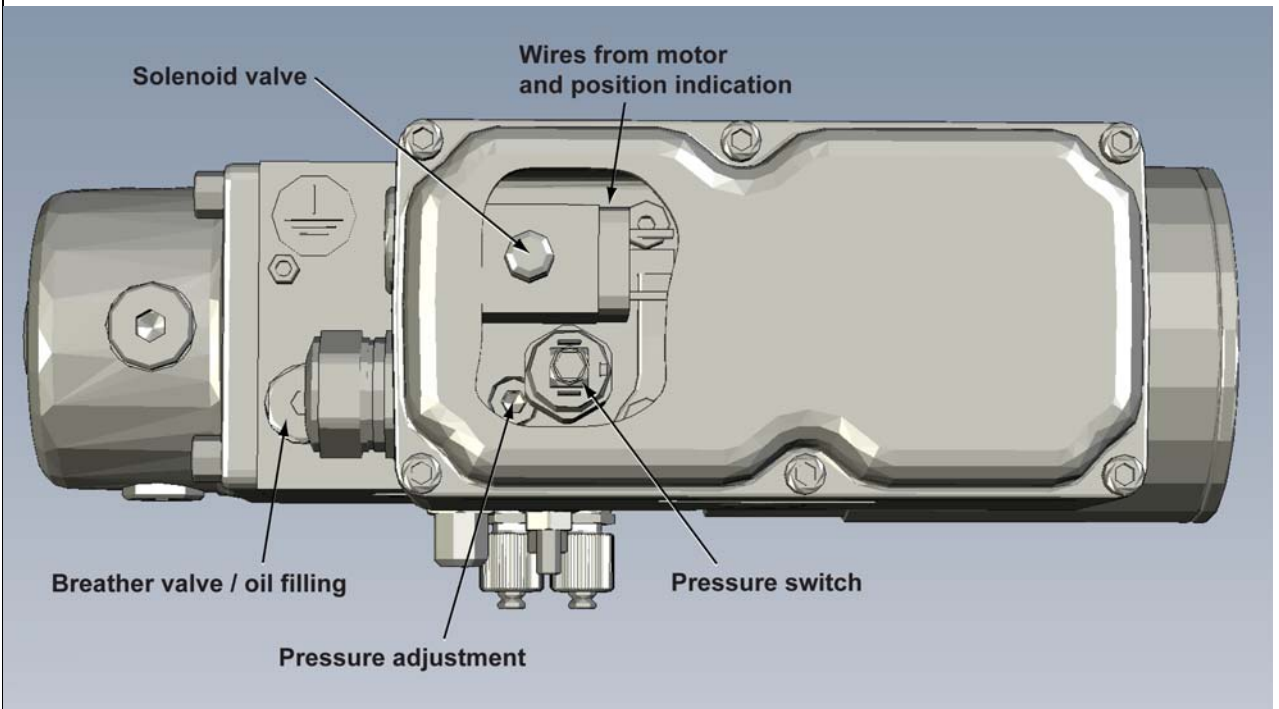

LPU-S Bottom View

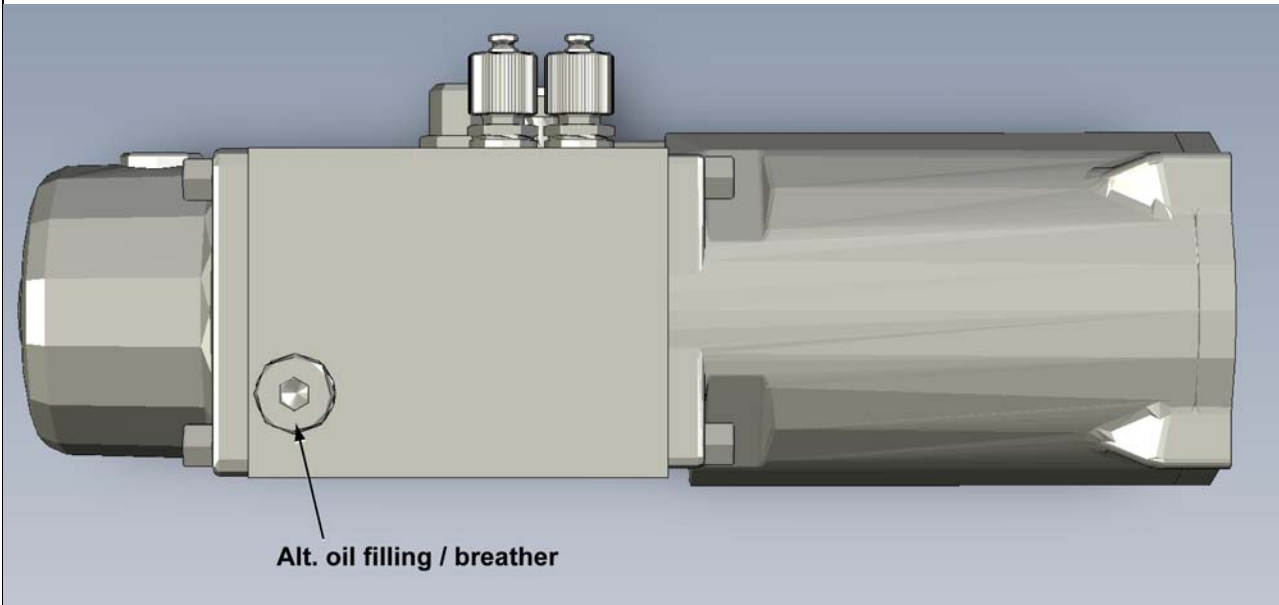

LPU-S-Ex-ia Overview

This Chapter Describes the LPU-S-Ex-ia with
Overview and Handling Instructions

Overview LPU-S-Ex-ia

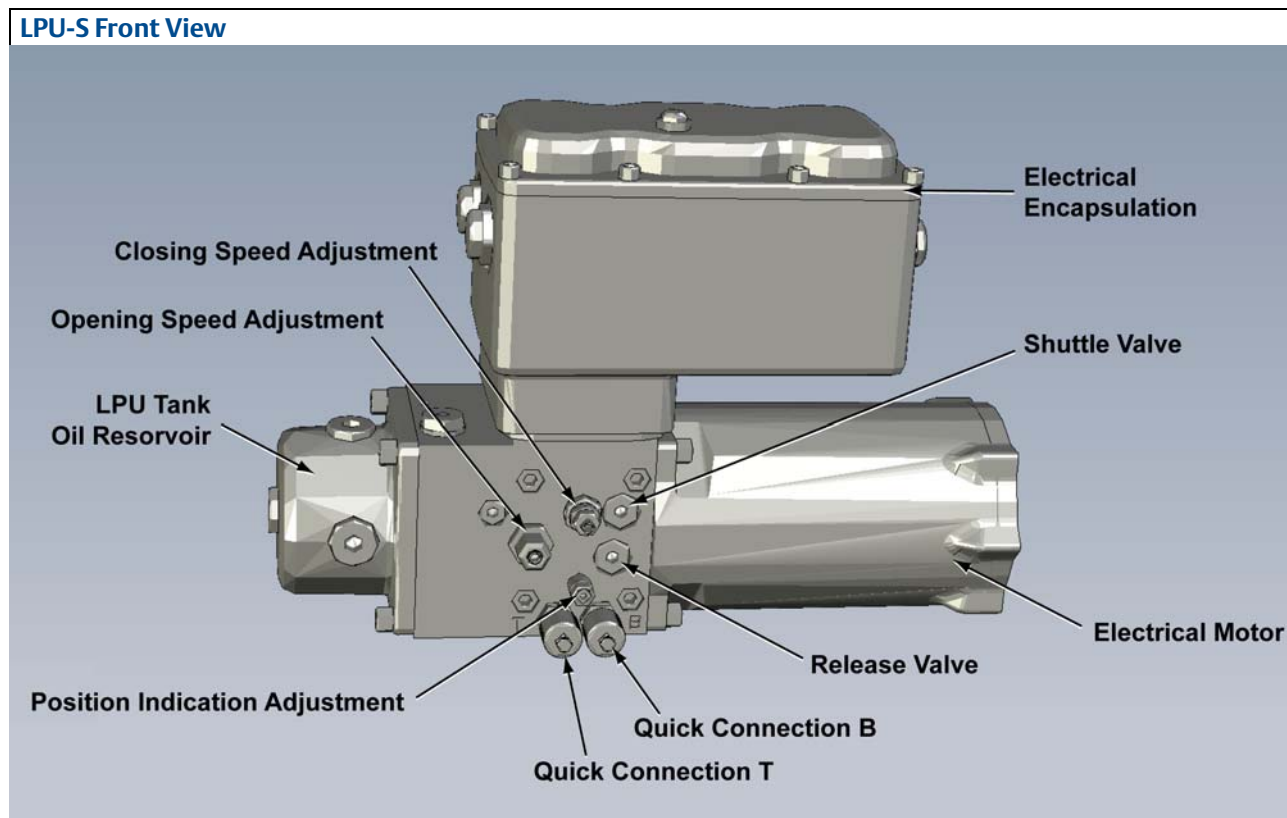

Emergency Operation	See “Emergency Operation of LPU V.2” on page 77.
How to Operate the LPU-S	See “Operating LPU-S 2” on page 73.
Fault Finding	See “Troubleshooting Guide LPU” on page 43.
Technical Data	For technical data see “LPU Technical Data” on page 111.
Cable Glands	See “Cable gland LPU-Ex and LPU-Ex-ia” on page 116.
Zener barrier	See “Zener barrier LPU-Ex-ia” on page 117.

LPU-S-Ex-ia Top View with top cover made partly transparent.

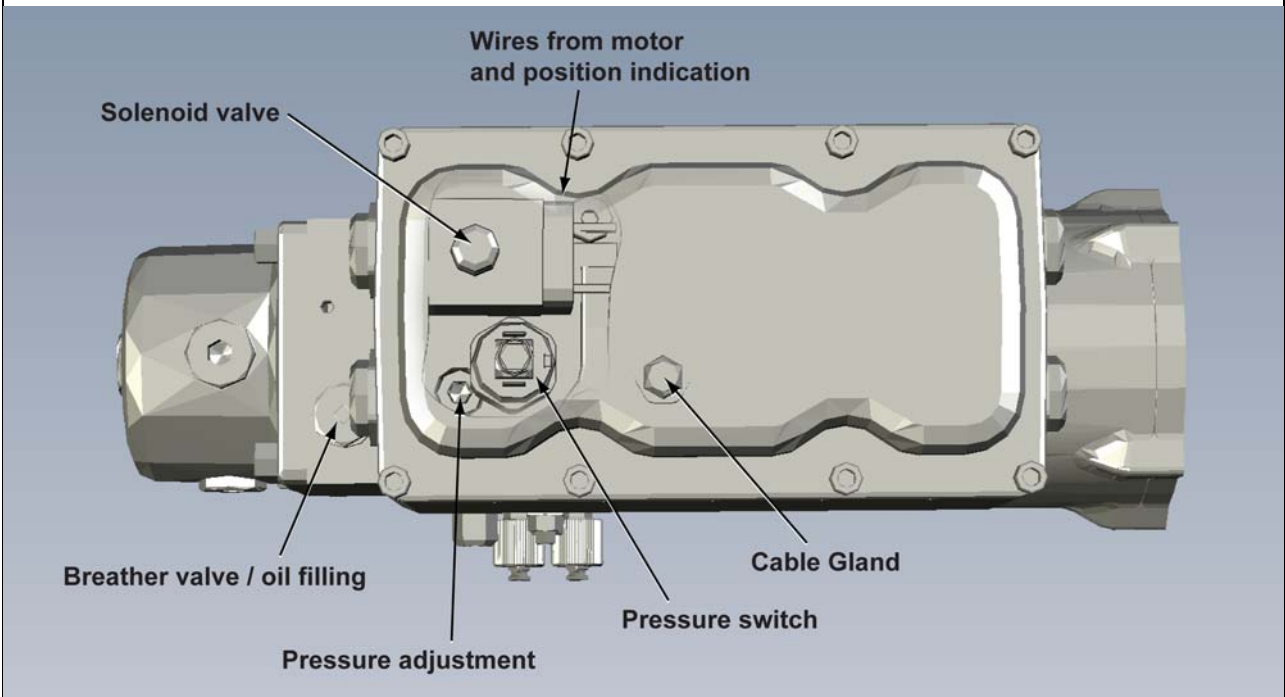

LPU-S Bottom View

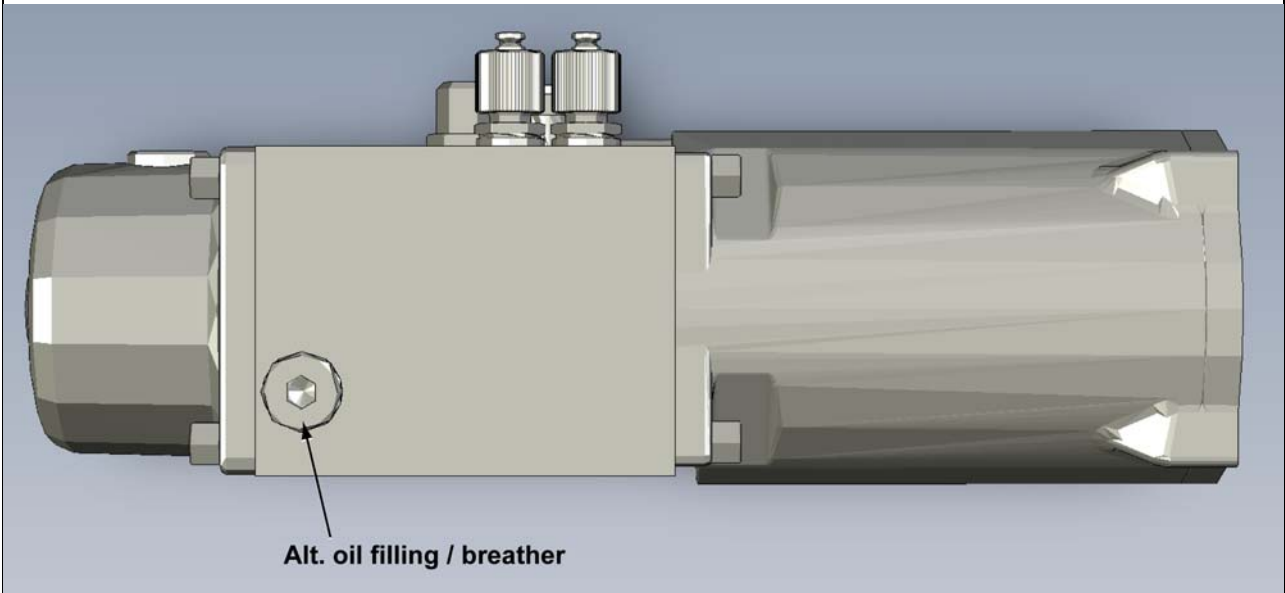

LPU-D Overview

This Chapter Describes the LPU-D with
Overview and Handling Instructions

Overview LPU-D

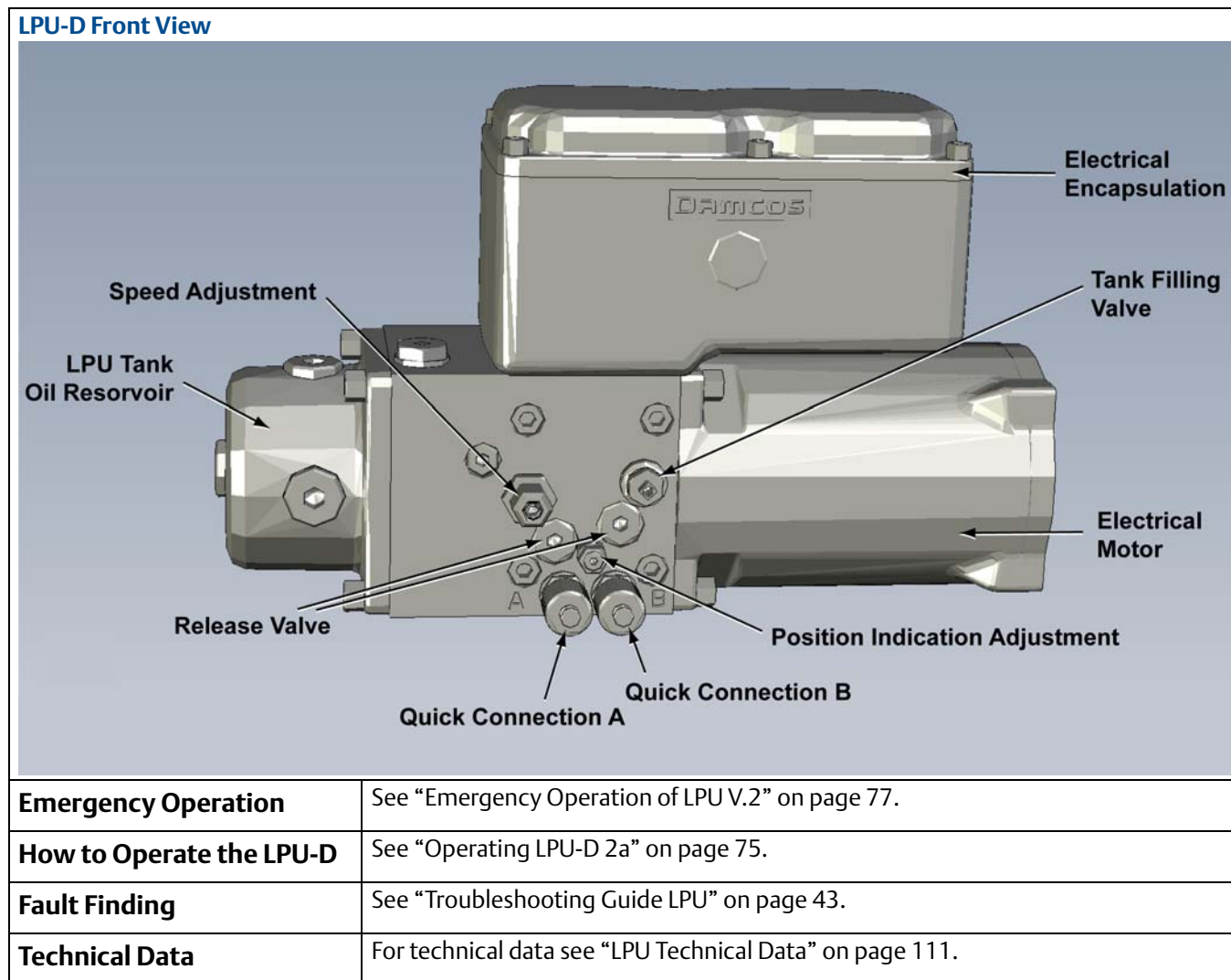

LPU-D Top View with top cover made partly transparent.

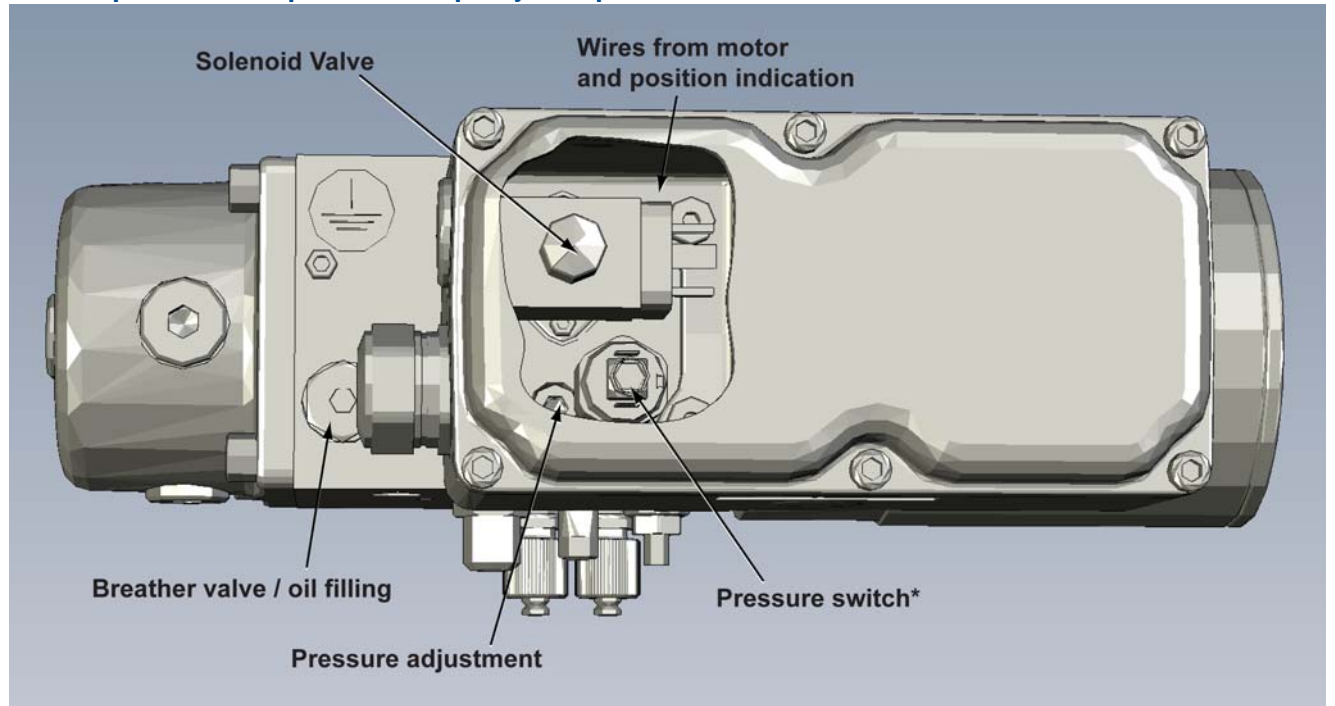

*)Pressure switch is not present in all versions of LPU-D!

LPU-D Bottom View

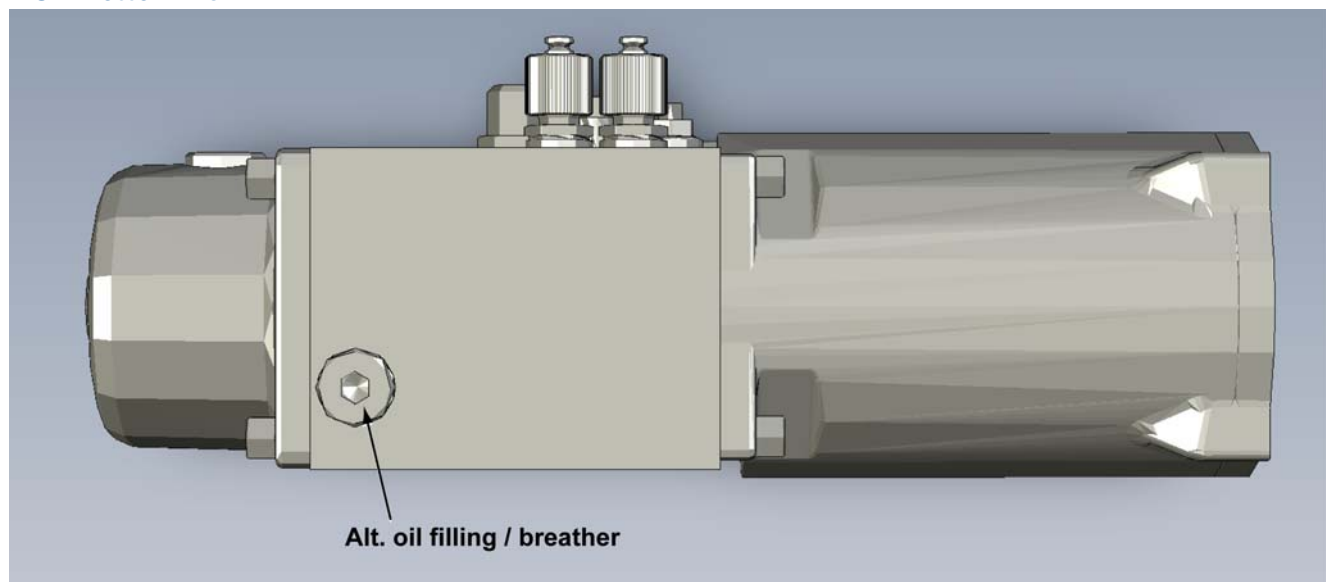

LPU-D-Ex Overview

This Chapter Describes the LPU-D-EX with
Overview and Handling Instructions

Overview LPU-D-Ex

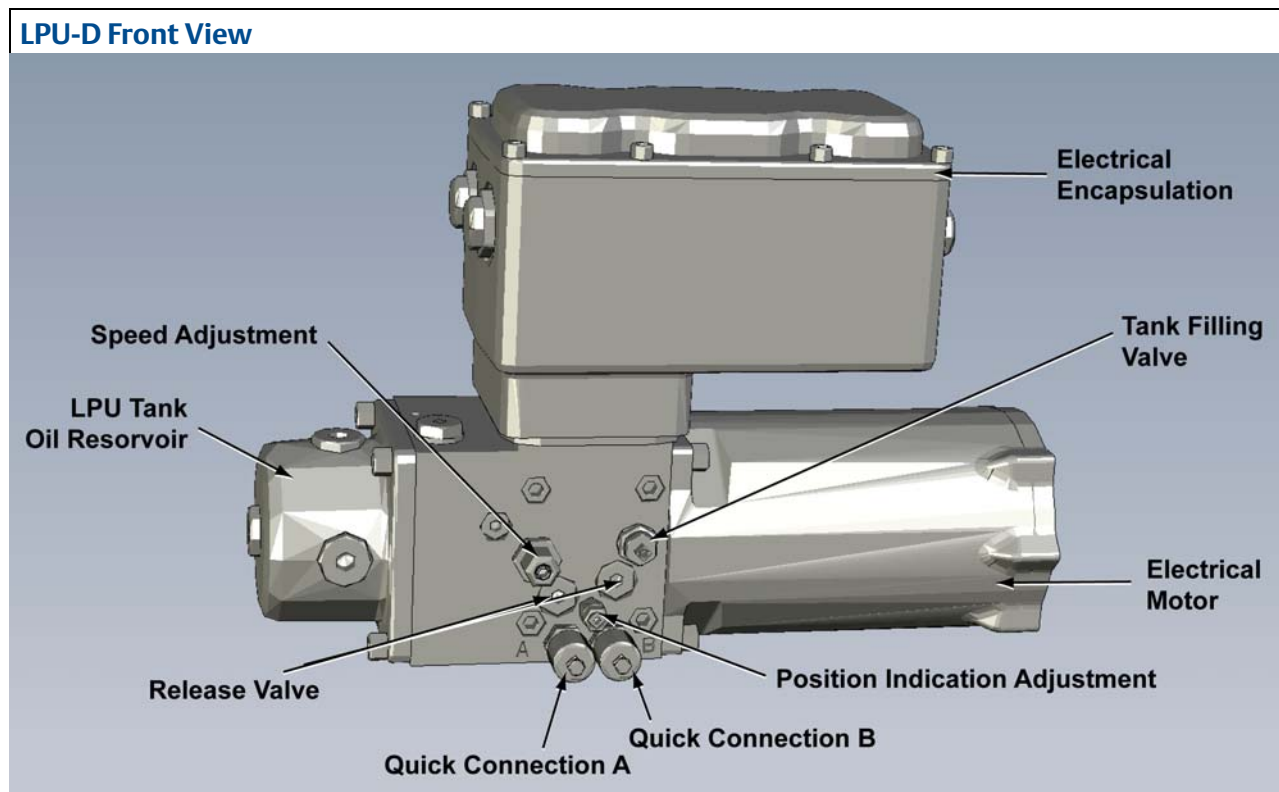

Emergency Operation	See “Emergency Operation of LPU V.2” on page 77.
How to Operate the LPU-D	See “Operating LPU-D 2a” on page 75.
Fault Finding	See “Troubleshooting Guide LPU” on page 43.
Technical Data	For technical data see “LPU Technical Data” on page 111.
Cable Glands	See “Cable Gland” on page 116.
Cable	See “Cables” on page 116.

LPU-D Top View with top cover made partly transparent.

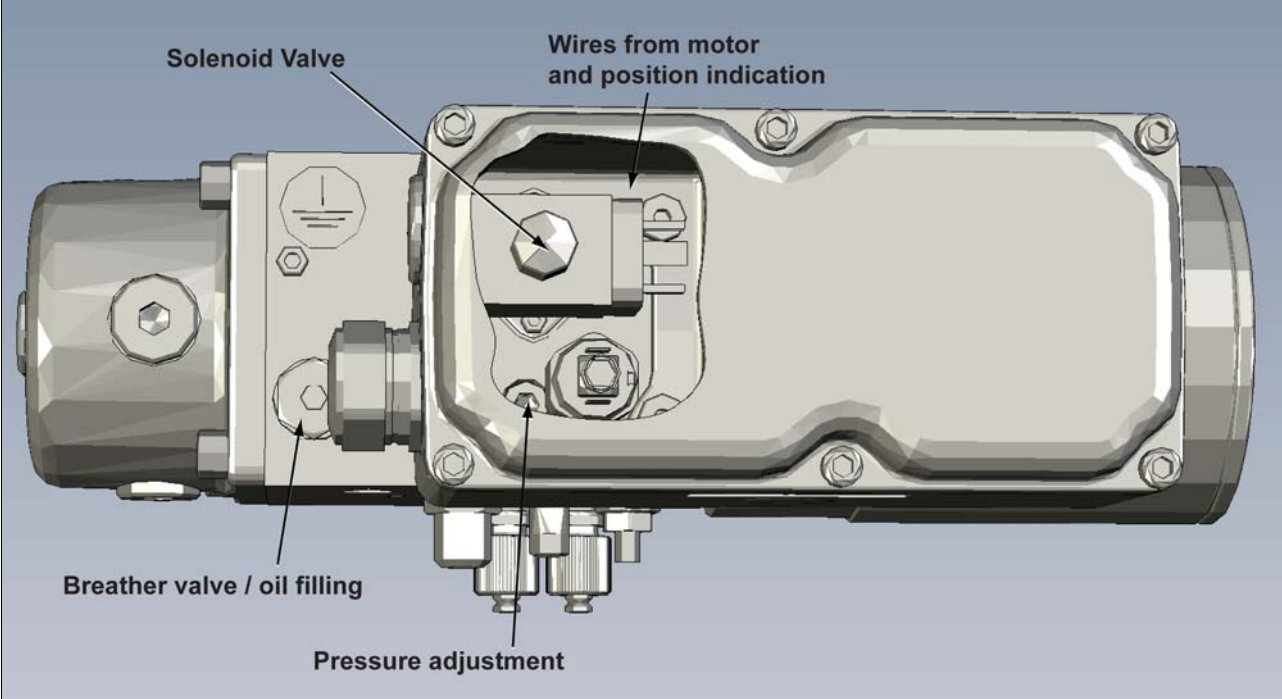

LPU-D Bottom View

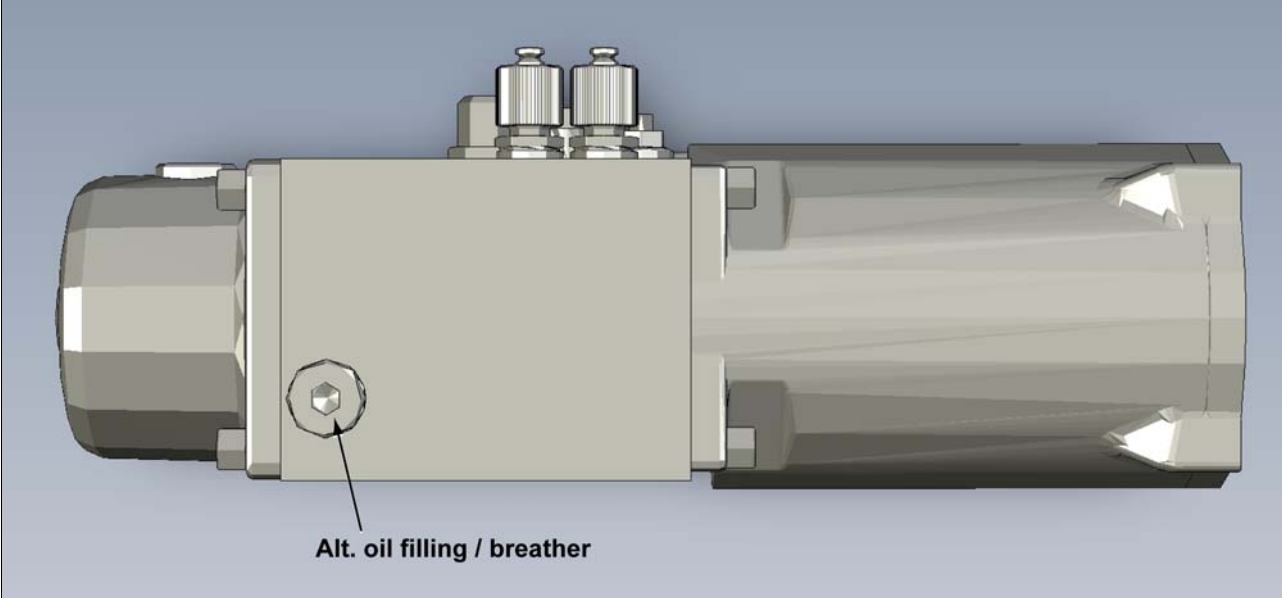

LPU-D-Ex-ia Overview

This Chapter Describes the LPU-D-Ex-ia with
Overview and Handling Instructions

Overview LPU-D-Ex-ia

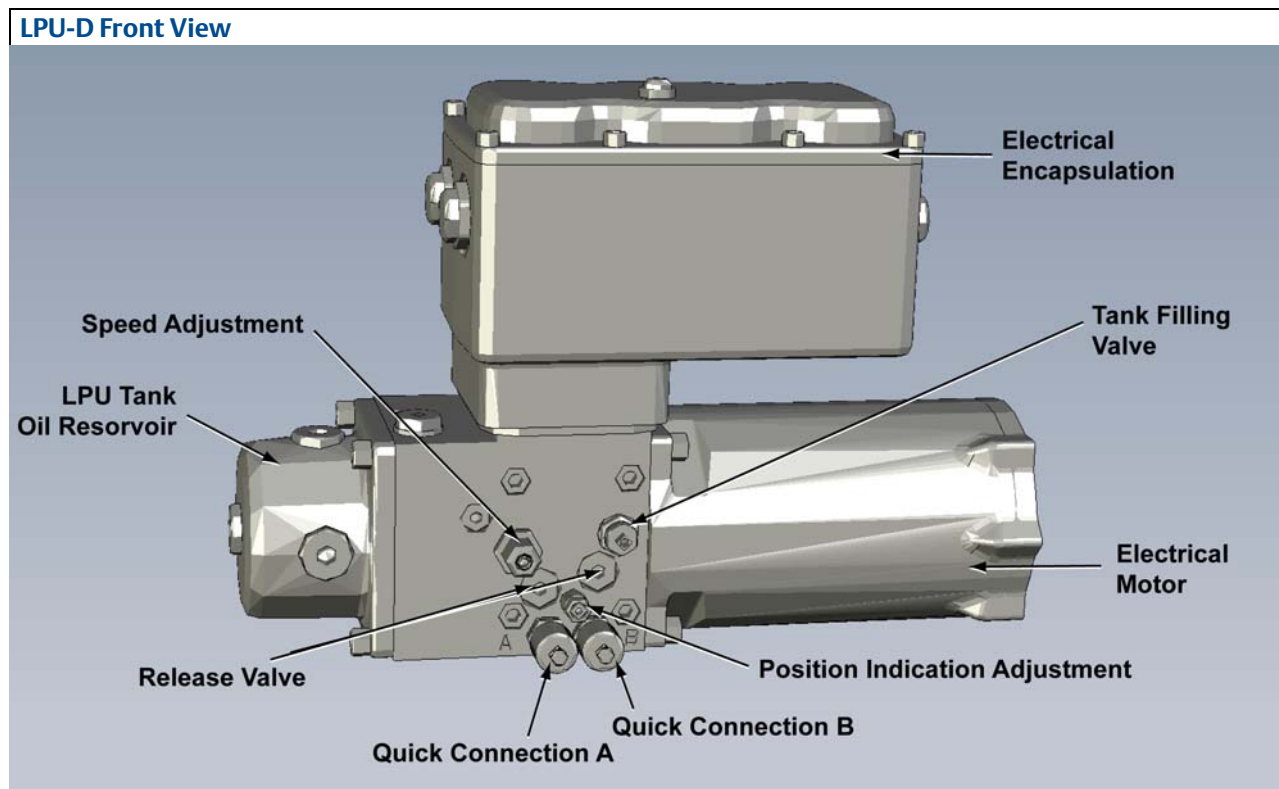

Emergency Operation	See "Emergency Operation of LPU V.2" on page 77.
How to Operate the LPU-D	See "Operating LPU-D 2a" on page 75.
Fault Finding	See "Troubleshooting Guide LPU" on page 43.
Technical Data	For technical data see "LPU Technical Data" on page 111.
Cable Glands	See "Cable Gland" on page 116.
Cable	See "Cables" on page 116.
Zener barrier	See "Zener barrier LPU-Ex-ia" on page 117.

LPU-D Top View with top cover made partly transparent.

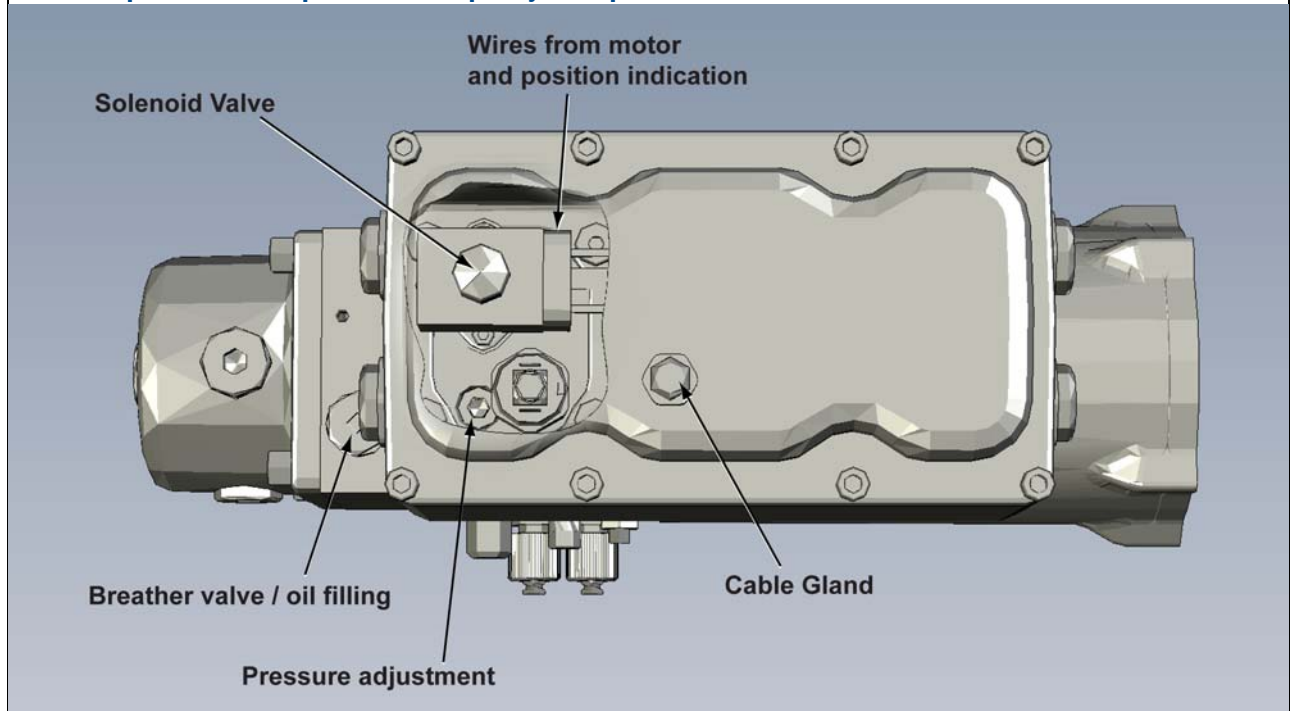

LPU-D Bottom View

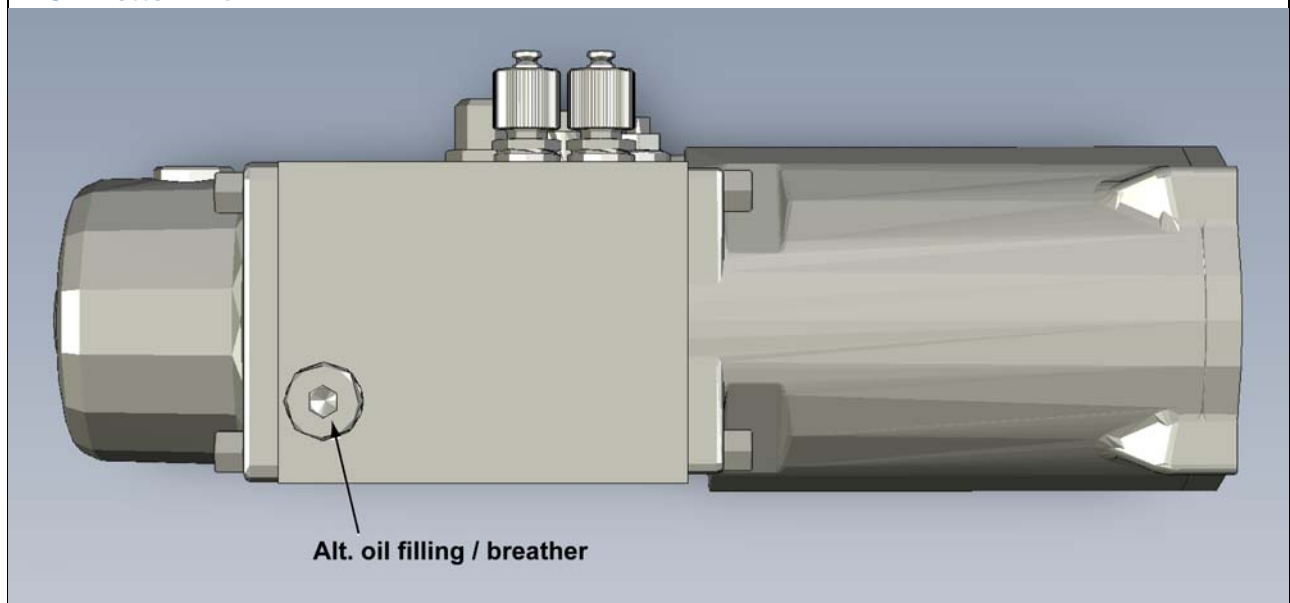

Troubleshooting Guide LPU

This Chapter Describes how to Identify
and Correct minor Problems for LPU

Fault Finding List LPU

ACTUATOR CONNECTED PROBLEM

- “Actuator only running in one direction (the unit can either only open or only close)” on page 53
- “LPU-D not maintaining pressure on actuator” on page 57
- “Spring actuator only partly closing or not starting to close” on page 58
- “Too little tank volume for operating actuator” on page 66
- “Spring actuator do not close by emergency hand pump operation” on page 69

ELECTRICAL PROBLEM

- “Unit drawing too much current” on page 65

EMERGENCY OPERATION

- “Emergency operation by key giving oil spillage through breather valve” on page 59
- “Emergency operation by key not possible, hydraulically locked” on page 59
- “Emergency operation by hand pump giving oil spillage through breather valve” on page 59
- “Emergency operation by hand pump not possible” on page 60
- “Spring actuator do not close by emergency hand pump operation” on page 69

LPU-D

- “LPU-D not maintaining pressure on actuator” on page 57

LPU-Ex

- “LPU-Ex motor do not run” on page 70
- “LPU-Ex has to be bulkhead mounted because of too little space or zone 0 at actuator” on page 71

LPU-S

- “LPU-S frequently restarting in open position” on page 47

MOTOR

- “LPU-Ex motor do not run” on page 70
- “Motor not running and is hot” on page 49
- “Motor not running and is Cold” on page 49
- “Motor not stopping” on page 50
- “Motor running hot, LPU is operating normally” on page 56
- “Motor running for a short time and stops High pressure on the port to which oil is led” on page 62
- “Motor running for a short time and stops” on page 62
- “Motor ”diving” in RPM in end position ” on page 63
- “Motor ”diving” in RPM as spring actuator opens” on page 63

OIL LEAKAGE

- “LPU leaking from bleeder valve when hand pump is mounted” on page 68
- “Oil spillage, generally” on page 64
- “Oil in electronic connection box” on page 64
- “Oil spillage from breather valve” on page 64

POSITION INDICATOR

“Position indicator errors” on page 72

PUMP

“Pump rendering too low (or no) pressure in one or both directions” on page 51

“Noise from pump, but only at low pressure” on page 54

“Noise from pump, but only at high pressure” on page 55

“Noise from pump at both high and low pressure” on page 55

“Pump not rendering sufficient oil at high pressure (“valve running too slowly”)” on page 61

“Pump not rendering sufficient oil at low pressure (“valve running too slowly”)” on page 61

PRESSURE

“Pump rendering too low (or no) pressure in one or both directions” on page 51

“LPU-D not maintaining pressure on actuator” on page 57

“LPU cannot raise pressure after hand pump operation (but no problems after remote operation)” on page 67

SOLENOID VALVE

“Solenoid valve not working” on page 52

LPU-S frequently restarting in open position

Action: Place pressure gauge on quick connection B.
Read maximum pressure and observe if pressure drops when motor stops.

Then if:

1. Pressure is raised to approx. 150 bar, but drops to 95 - 105 bar before motor is restarted.
Goto "Leakage in the hydraulic system between check valve and actuator or in actuator" on page 47.
2. Pressure is raised to approx. 150 bar and motor stops, but is restarted before pressure drops below 115 bar.
Goto "Fault on pressure switch or wires, possibly on printed circuit board" on page 47.
3. Pressure is raised to below 120 bar and drops to 90 - 110 bar before motor is restarted.
Goto "Large leakage in the hydraulic system, or misadjusted safety valve" on page 48.

1. Leakage in the hydraulic system between check valve and actuator or in actuator

Action: Mount hand pump, pressure gauge is already mounted (see above), and open actuator fully by hand pump.

Then if:

- Pressure remains constant
Leakage in solenoid valve or leakage at check valve in valve block:
 - Check for leakage in solenoid valve.
 - Check valve in valve block for external leakage, e.g. at pressure switch or closing speed adjustment. Check for external leakage and if no leakage is found replace solenoid valve or check valve.
- Pressure drops
Leakage in bypass valve at actuator, release valve, shuttle valve, emergency valve or actuator.
 - Check o-rings on emergency slide and shuttle valve, possibly replace release valve or shuttle valve if shuttle valve is version with internal slide.
 - Check that bypass valve in actuator is closed.
 - Possibly dismount LPU from actuator and check if actuator has leakage, internal or external.

2. Fault on pressure switch or wires, possibly on printed circuit board

Action: Wires to pressure switch are dismantled from pressure switch and connected to each others, simulating high pressure.

Caution! For LPU power these wires are supplied by 230 V. When the LPU is energized, the motor must run for 7 - 12 seconds, then stop, and not start until the wires are disconnected from each other.

Pressure Switch is electrically measured fully pressurized for short breaks (loose connections). Pressure gauge is mounted on quick connection for B and pressure is read when pressure switch breaks.

Then if:

- Pressure switch breaks above 105 bar

- Pressure switch is adjusted, so that pressure switch breaks by falling pressure at 100 ± 5 bar. Pressure switch must close below 125 bar by rising pressure.
- Short breaks of pressure switch
 - Replace pressure switch! See “Replace pressure switch” on page 109.
- Pressure switch breaks below 105 bar, no short breaks
 - Check electrical connections from pressure switch. If no other faults are detected, replace printed circuit board. See “Replace Printed Circuit Board” on page 105.

3. Large leakage in the hydraulic system, or misadjusted safety valve

Action: Mount hand pump, actuator is fully opened by hand pump, pressure gauge is mounted.

- Then if:**
- Pressure remains constant
Leakage in solenoid valve, quick connection B or external leakage, e.g. at pressure switch. Possibly too low adjusted pressure at pump relief valve (pump safety valve).
 - Check for external leakage, if no leakage, adjust pump pressure (see “Pump pressure adjustment for LPU” on page 85). If this cannot be adjusted any higher, check internal sealings and flow reducing valve (opening speed adjustment).
 - Replace solenoid valve (see “Replace Solenoid Valve in LPU-D” on page 107), flow reducing valve or sealings. Then safety valve is readjusted to 150 bar (see “Pump pressure adjustment for LPU” on page 85).

Note! If oil has too low viscosity or is very hot this might be the reason for a too low pressure.

- Pressure drops
Leakage in actuator, or possibly bypass valve, release valve, emergency valve or shuttle valve.
 - Check o-rings on shuttle valve and emergency valve, possibly replace release valve, see “Replace release valve in LPU” on page 99.
 - Check for external leakage.

Motor not running and is hot

Action: Check that electrical connections to motor and capacitor are OK! Open bypass to release possible pressure on pump and try to run the motor with opened bypass.

- Then if:**
- Motor is running, but stops when bypass is closed.
Incorrectly connected motor or fault on motor or wires.
 - Low supply voltage.
 - Defective flow reducing valve, see “Motor ”diving” in RPM in end position ” on page 63.
 - Motor is not running at all, even though bypass is opened.
 - Disconnect current to LPU for measurement of resistance from N to CL and from N to OP on printed circuit board (the easiest way is to disconnect the capacitor). Resistance must be 15 Ω . The capacitor can on rare occasions be defective.
If connections and resistance are OK, the pump has stuck. New pump set is then mounted, see “Replace Pump in LPU” on page 93. Reason for defective pump should be found, e.g. insufficient quantity of oil, no stop of motor, impurities in oil etc.

Note! For LPU-Ex the temperature cut-off box might have interrupted power to motor due to too high motor temperature. If this is the case the motor needs time to cool down, then 24 V to LPU-Ex is interrupted for 10 seconds and LPU-Ex should be ready to run again.

Motor not running and is Cold

- Action:**
- Check that there is 220 - 230 V AC over “N” and “open” or “close”, respectively when trying to operate.
 - Check that electrical connections to motor are OK. If the black wire is not connected, motor cannot run.
 - Dismount the motor wires. Check the resistance on the printed circuit board from “N” to the centre motor wire, and from “open” and “close”, respectively to the two other motor connections. There must not be a measurable resistance.
 - Check the resistance in the motor itself, there must be approximately 15 Ω . between the black wire and each of the others. If the resistance differs widely, the motor is to be replaced.

Note! For LPU-Ex the temperature cut-off box will interrupt power to motor if 24 V is not present or bounces when it is connected.

Motor not stopping

- Action:**
- The pressure on B-port is measured.
If the pressure is below 120 bar, while motor is running, see “Pump rendering too low (or no) pressure in one or both directions” on page 51.
 - Wires to the pressure switch are dismantled and connected to each others, simulating high pressure.

Caution! LPU-Power wires are supplied by 230 V. When LPU terminal (“open”) is energized in the relevant direction, motor must stop after 7 - 12 seconds.
LPU-S-power must not be restarted before wires are disconnected.
LPU-D-power must not be restarted before power is disconnected and reconnected again.

- If pressure switch is correctly connected, and the pressure is correct, check that pressure switch is closing as required. Pressure switches must close at maximum 125 bar and break between 95 to 105 bar.
Adjust and if necessary replace pressure switches, see “Replace pressure switch” on page 109.

LPU-D-P-Net

If motor does not stop at all, the printed circuit board must be replaced, see “Replace Printed Circuit Board” on page 105.

If the motor runs longer than normal, but then stops, the fault should be found in the position indicator, the calibration of the analogue indicator or setup of extra time in circuit board. Check, that the position signal is really “0” or “100”.

LPU-S-P-Net

If motor does not stop at all and pressure on B-port is above 125 bar, the printed circuit board must be replaced, see “Replace Printed Circuit Board” on page 105.

If the motor runs longer than normal, but then stops, the fault should be found in the position indicator, the pressure switch, the calibration of the analogue indicator or setup of extra time in circuit board. Check that the position signal really is “100”.

LPU Power Control

Check that the pressure switch is correctly connected. See “Pump rendering too low (or no) pressure in one or both directions” on page 51.

Pump rendering too low (or no) pressure in one or both directions

- Action:**
- Check that solenoid valve is clicking at connection. If not see “Solenoid valve not working” on page 52.
 - If pump does not render any pressure at all check oil level.
Mount a plug giving a possibility of connecting compressed air instead of breather valve and pressurize tank with maximum 2.5 bar, while the pump is running. If air pressure in tank does not solve the problem, or if the pump renders pressure (but too low), hand pump with pressure gauge is mounted and actuator is fully opened by hand pump.

LPU-D

If no opening pressure check that by-pass for tank filling (in front of LPU) is closed.

LPU-Power

Check that power supply is connected to terminal “open” and that terminal “close” is not connected.

If pressure remains constantly low

At too low pressure in one direction (LPU-S) or both directions (LPU-D) the safety valve is adjusted according to instruction (see “Pump pressure adjustment for LPU” on page 85). If higher pressure cannot be obtained, there is a possible leakage in the solenoid valve, or at DPCV-slide (LPU-D), or at clearance between pump stator and rotor.

De-airing the flow reducing valve may be necessary, see “Pump not rendering sufficient oil at low pressure (“valve running too slowly)” on page 61.

If pressure drops quickly

Leakage in bypass valve (actuator), shuttle or emergency valve (LPU-S) or release valve. Check o-rings on valves and if necessary replace release valve (see “Replace release valve in LPU” on page 99) or shuttle valve.

Solenoid valve not working

- Action:**
- Check that solenoid valve is energized (230 V on terminals “N” and “SV”).
 - If coil is energized, but solenoid valve does not work, the resistance of the coil is measured (LPU-D). The coil must have a resistance of approximate 520 Ω for LPU-D. Due to a diode bridge resistance cannot be measured for LPU-S coil. Another way to check the coil is to loosen it and try to lift the coil when energized. If coil does not work, it is replaced.
 - If coil works, the valve is to be replaced. See “Replace Solenoid Valve in LPU-D” on page 107.

Actuator only running in one direction (the unit can either only open or only close)

LPU-D

If LPU-D can close, but not open check by-pass valve for oil filling. Check that solenoid valve is powered and working and that free travel of solenoid valve slide is OK.

LPU-S

If actuator can close, but not open see “Pump rendering too low (or no) pressure in one or both directions” on page 51. If actuator can open, but not close, see “Spring actuator only partly closing or not starting to close” on page 58.

Note! BRCF and KF can always be closed by opening bypass valve at actuator. KFR can be closed opening bypass valve and lifting valve for emergency operation by hand pump.

Noise from pump, but only at low pressure

Action: Adjust speed from maximum to minimum (see “Speed adjustment for Actuator on LPU (v.2)” on page 83). If possible, place key on emergency operation shaft of the actuator and hold against rotating direction (i.e. operating pressure must be approximate 30 bar) (only possible for BRC 125, 250, 500).



Warning! Beware of huge force, actuator cannot be stopped by hand!

Then if:

- Sound disappears
Too low compression of O-ring on motor shaft, so that rotor is vibrating on coupling.
Replace O-ring.
- Sound is unchanged
A pump piston is operating too tightly and does not follow the ball bearing curve during movement. At relatively high pressure it is pressed out hydraulically. The sound can disappear at starting-up. Otherwise pump is dismantled and pistons and rotor are checked for coverings or burrs.

Note! If pump rotor has to be replaced the stator version has to be checked (check placement and number of expanding plugs). If stator versions are different both rotor and stator must be exchanged (complete pump set, see “Replace Pump in LPU” on page 93).

Noise from pump, but only at high pressure

- Reason:**
- Air in the pump if actuator has not been properly de-aired. Check oil level in tank.
 - Too small tank volume for large actuators or long pipes in system.
 - Piston in pump is sticking.
A pump piston is operating too tightly and does not follow the ball bearing curve during movement. At relatively high pressure it is pressed out hydraulically. The sound can disappear at starting-up. Otherwise pump is dismantled and pistons and rotor are checked for coverings or burrs.

Note! If pump rotor has to be replaced the stator version has to be checked (check placement and number of expanding plugs). If stator versions are different both rotor and stator must be exchanged (complete pump set, see “Replace Pump in LPU” on page 93).

Noise from pump at both high and low pressure

- Reason:** Motor and pump are not co-axial, pump stator is not mounted firmly in the block.
- Action:**
- Check steering pins between blocks.
 - Dismount pump and check that remounted stator is perpendicular to valve block. See “Replace Pump in LPU” on page 93 for more information.

Motor running hot, LPU is operating normally

Caution! Motor is designed for 25% duty cycle only.

- Action:**
- LPU-S
Observe that LPU does not restart.
If it is restarting frequently, the motor is running hot. See “LPU-S frequently restarting in open position” on page 47.
 - Measure the supply voltage (220 - 230 V AC) to LPU.
If it differs widely from the required voltage, the voltage must be modified.
 - Measure the resistance over the motor windings, on the terminal (easiest with disconnected capacitor). There must be approximately 15 Ω between “N” and “OPEN” and “CLOSE” respectively.
If this resistance is not observed, the motor is to be replaced.
 - The mechanical resistance of the motor can be too high.
If it cannot be turned easily with the fingers, it is to be replaced.
 - The mechanical resistance of the pump can be too high, if ball bearing is blocked.
Dismount valve block and pump rotor as to change pump (see “Replace Pump in LPU” on page 93) and check if ball bearing can rotate freely.

LPU-D not maintaining pressure on actuator

Pressure drops only on 1 port

- Leakage in check valves for DPCV or release valve.
Change check valves for DPCV.
- A leakage in actuator might give pressure drop on only one port.
Replace the seal set in actuator with a new one.

Pressure drops on both ports

Leakage in bypass valve (actuator) or actuator.

- Check bypass valve, possibly replace release valve (see “Replace release valve in LPU” on page 99).
- Check actuator.

Spring actuator only partly closing or not starting to close

Action: Check that throttle valve for adjustment of closing speed is not blocked.
Open bypass while motor is not operated.

- Then if:**
- Spring actuator closes
Solenoid valve coil is still energized while valve is required to be closed!
This might be due to that valve has been opened by hand pump or filter below pressure switch is blocked or too fast closing speed so that emergency valve has no pressure and is closing before actuator is closed.
If this is the case then:
 - repeat opening and closing command (by remote operation) for LPU.
If closing does not function check that the power for the solenoid valve is turned off.
If not check relay in control cabinet (power controlled with separately connected solenoid valve), or on printed circuit board (P-Net).
Else remove coil from solenoid valve. Check filter below pressure switch (valve must be closed). Adjust closing speed valve to fully closed, open it 1 revolution and check again. If the actuator now closes closing speed can be increased step by step. If closing speed cannot be sufficient then B-line between LPU and actuator is checked for blocks that can throttle oil flow.
 - Spring actuator remains open
The fault is to be found outside the LPU.
For KFR push button for emergency operation might be blocked. Valve is sticking, or fault on spring actuator.

Emergency operation by key giving oil spillage through breather valve

Reason: When valve is emergency operated by key, oil is pumped from actuator to LPU tank and further on to the actuator. If the oil flow from LPU tank to actuator gives more than 3 bar pressure drop, the oil can be pressed through the breather valve instead of back to actuator.

Action: Carrying out emergency operation at the same opening and closing speed to which the valve is set at remote operation can solve the problem.

Caution! Avoid replacement of breather valve with plug, as this might result in too high pressure at motor shaft sealing.

Emergency operation by key not possible, hydraulically locked

Reason: Bypass not active or bypass valve is blocked.

Action: Open bypass valve and keep it opened during emergency operation. If emergency operation is still locked - bypass valve is to be dismantled and checked. If bore contains dirt, it has to be removed.

Emergency operation by hand pump giving oil spillage through breather valve

Reason: Tank pressure in LPU is too high. The pressure drop over quick connections due to very fast operation or defective or not properly connected quick connections. If LPU is bulkhead mounted the pressure drop might be in piping as well if they are long or if the inside diameter is narrow.

If oil cannot return to the hand pump tank, an LPU-S may be opened without problems. When valve closes again, the LPU tank overflows.

When LPU's closed system is filled with oil, the exceeding oil is let out through the breather valve to prevent overpressure in the LPU.

Emergency operation by hand pump not possible

- Reason:**
- Hand pump is building up pressure, but actuator is not moving
 - Slide for shuttle valve is sticking, so that change over to emergency operation cannot take place (LPU-S).
 - Outlet from actuator blocked so that return oil cannot pass.
 - Fault on quick connections, so that check valve in hand pump quick connection is not opening.
 - Hand pump is pumping oil, but cannot build up pressure
 - Leakage in DPCV (LPU-D), bypass valve, release valve, emergency valve (LPU-S) or actuator
 - After a few strokes, hand pump is not pumping oil
 - Insufficient oil in hand pump tank

Pump not rendering sufficient oil at high pressure (“valve running too slowly”)

Reason: LPU is built up, so that oil quantity from pump, independent of adjusted speed, is reduced to approximate 240 cm³/min from pressure exceeding 75 bar. If flow is considerably below this quantity, see “Pump rendering too low (or no) pressure in one or both directions” on page 51.
The pressure should only exceed 65 bar for a few seconds, when breaking valve away or closing valve.

Pump not rendering sufficient oil at low pressure (“valve running too slowly”)

- Action:**
- Check adjustment of opening and closing speed (see “Speed adjustment for Actuator on LPU (v.2)” on page 83).
 - While pump is running at high pressure in end position, valve housing for speed adjustment is loosened by a 19 mm wrench (must be turned maximum 3 turns, as there is full pump pressure below housing), until airless oil is running from it. Then valve housing is tightened, and pump flow is checked again. If pump flow is still not OK, dismount adjusting screw for speed control, check with a screw driver that the ball bearing behind this can be moved back and forth by pressing it. Check mobility of the piston in valve housing for speed adjustment.
 - Dismount tank and check if filter in suction pipe is blocked.
 - Dismount tank and valve block, check the mobility of the bearing, and observe if any pistons in rotor are sticking. Stator is dismounted (pressed out from the tan side), and blown through, to remove plugging, if any, in the longitudinal holes.
 - Remounting of stator: stator must be pressed in until direction pin is below surface of block. When seated correctly, the free stator length is approximate 19 mm. Do not use metal hammer directly on the stator. (See “Replace Pump in LPU” on page 93).

Motor running for a short time and stops High pressure on the port to which oil is led

Action: Mount pressure gauge on quick connection on return oil from actuator (LPU-D). At the same time check that actuator is moving.

Then if:

- High pressure on return oil. Actuator is not moving, or is hardly moving
DPCV does not open check valve for return oil. Check slide, sealings and check-valves for DPCV.
- Low pressure on return oil. Actuator is running, but not to end position
Operating pressure for actuator too high due to blocking in return, could be dirt in holes near the port surface or in actuator.
- Low pressure on return oil. Actuator is not moving, or is hardly moving
Operating pressure for actuator too high due to blocking in return, could be dirt in holes near the port surface or in actuator.
Fault in actuator, valve (requires a too high torque or more than 7 seconds before breaking away from the seat), or choice of actuator for the valve in question.

Motor running for a short time and stops

Reason: Pressure switch does not break, or fault on control print.

Action:

- Try dismantling a wire for the pressure switch in question. LPU shall then operate as long as terminal is energized. If not so, there is a fault on the printed circuit board which is then replaced (see "Replace Printed Circuit Board" on page 105).
- Control card receives a signal for stop of motor from pressure switch. For LPU-S and LPU-D-Power, pressure switch connections and adjustment are to be checked. Pressure switch is possibly replaced (see "Replace pressure switch" on page 109).

Motor "diving" in RPM in end position

Reason: Voltage too low, pump relief valve misadjusted, defective flow reducing valve (the displacement of the pump is not reduced at high pressure), fault in motor, or faulty connection of motor. Possibly fault in capacitor/connection.

- Action:**
- Check voltage over the terminals during operation. If it is considerably below 220 V AC, the fault is to be found here. Take corrective measures. (LPU can operate down to 185V at 60 Hz, but such a low voltage is an indication of something being wrong).
 - Check connection of motor.
 - Check connection of capacitor.
 - Check the maximum pressure (connect a pressure gauge to the quick connection pressurised). Possibly adjust relief valve to 150 bar.
 - Dismount adjusting screw for speed control, check with a screwdriver that the ball bearing behind this can be moved back and forth by pressing it.

Motor "diving" in RPM as spring actuator opens

Reason: Voltage too low, mechanical resistance in ball bearing around pump, faulty connected motor or fault in capacitor.

Oil spillage, generally

Avoid starting motor until the correct level in tank has been ensured. After elimination of faults, replenish tank with the correct oil for the specific system.

Oil in electronic connection box

- Action:**
- At a large oil volume in electric connection box: Avoid starting the motor until having ensured that the oil level in tank is OK.
 - Check pressure switch and solenoid valve for visible leakage, possibly by starting pump.
 - For LPU-S, leakage at pressure switch or solenoid valve will result in a pressure drop, so that the LPU motor / pump restarts if this function is engaged.
 - Possible leakage from safety valve cannot be positively identified, until electronic connection box has been dismantled.
 - Leakage from actuator, led through the position indicator can occur at leakage from actuator to indicator. In special cases, oil may even be led through the power/bus cables from one LPU to the next.
 - At leaking shaft seal on the electrical motor, the oil can run through motor and up in electronic connection box.
 - After repair of defects, the tank is replenished with the correct oil for the specific system.

Oil spillage from breather valve

- Oil spillage at emergency operation: see “Emergency operation by key giving oil spillage through breather valve” on page 59 or “Emergency operation by hand pump giving oil spillage through breather valve” on page 59.
- Oil spillage during operation when motor is changing direction: Compressed air in actuator. Actuator is to be de-aired. Especially linear actuators (KC, KF and KFR) may have to be loosened from valve to be able to close completely before de-airing of actuator.
- Oil spillage when BRCF closes: Possibly air in actuator, actuator is to be de-aired. Breather valve shall only be placed in BRCF or in LPU, not in both. Breather valve to be placed at highest possible tank level. Too fast closing of actuator giving a high return pressure at closing letting oil out of breather valve. Adjust closing speed to slower closing.
- Oil spillage when KF or KFR closes: Possibly air in actuator, actuator is to be de-aired. Breather valve must always be placed on top of KFR, and in LPU, where breather valve has to be placed at highest possible tank level. Too fast closing of actuator giving a high return pressure at closing letting oil out of breather valve. Adjust closing speed to slower closing.
- Oil spillage at temperature rise in LPU-system: Oil tank overfilled or too great expansion at heating up, dependent on oil volume. At a large oil spillage due to heating up, an extended tank should be used.

Unit drawing too much current

- Reason:**
- Mechanical resistance in motor
 - Mechanical resistance in pump
 - Too small winding resistance in motor meaning a 110 V motor has been used instead of 230 V motor
 - Too high or too low supply voltage
 - Too low frequency
 - Faulty electrical connection of motor
 - Defective capacitor

Too little tank volume for operating actuator

LPU

- Incorrect oil filling and de-airing of actuator. Check oil filling.
- Too high compressibility of oil in pipes between hand pump and LPU or between LPU and actuator. Try more carefully de-airing of piping. It might be necessary to use an expansion tank at LPU. Expansion tank at hand pump is not allowed as it gives risk of oil spillage at breather valve.

LPU-S

No connection from LPU-tank and hand pump tank to actuator tank/spring chamber. Hand pump tank and LPU tank need tank connection to actuator to maintain constant oil volume in system for mix of emergency and remote operation.

For large actuators

Oil compression by pressurizing actuator needs more oil than a standard tank can give. Use pressure tank for LPU. This is the case for e.g. BRC/BRCF 16000, BRC 32000, BRCF 4000 HT, BRCF 8000 HT, KC 325 and KC 400.

LPU cannot raise pressure after hand pump operation (but no problems after remote operation)

- Reason:**
- Leakage from LPU to hand pump.
 - Portable hand pump must be disconnected.
 - Make sure that by-pass at possible bulkhead hand pump is closed.
 - Try to operate valve in the selected direction by hand pump first, then by LPU. If LPU can raise pressure now, the DPCV valve slide has too high friction. If problem is not solved DPCV is leaking due to defect non return valve or slide is sticking.

LPU leaking from bleeder valve when hand pump is mounted

Reason: For LPU-S

- Bad T-connection from LPU to hand pump:
 - Check piping and connections.
 - Check that no by-pass valve is placed in T-side of hand pump, as free T-flow is essential for function of hand pump.

For LPU-D

- At remote operating LPU is compressing oil in piping for hand pump or, when bulkhead mounted LPU, for actuator. The oil volume needed for compressing this oil is depending on oil volume in pipes and proper de-airing. This oil volume will be taken from hand pump tank and cannot be returned because of DPCV in hand pump.
 - If de-airing of piping is OK a pressure tank at LPU has to be mounted.

Caution! Pressure tank at hand pump is not allowed.

Spring actuator do not close by emergency hand pump operation

- Reason:**
- Spring actuators will not close by changing bulkhead hand pump to close, as there will be no pressure rise to open the DPCV.
 - Close actuator through by-pass valve at hand pump or actuator instead. Close by-pass valve when the actuator is fully closed.

For KFR

If KFR is emergency opened at the actuator, an opening operation followed by closing the actuator is necessary. Opening operation can be made by hand pump or remote control.

LPU-Ex motor do not run

Reason: LPU-Ex-motors contain temperature sensors that have to be reset manually. After motor cut-off by temperature sensors they have to be reset by turning off 24 V power for at least 10 sec. If this don't solve the problem, see "Motor not running and is hot" on page 49 and "Motor not running and is Cold" on page 49.

LPU-Ex has to be bulkhead mounted because of too little space or zone 0 at actuator

Like other LPU's LPU-Ex can be bulkhead mounted by means of BB-block or BB-VPI, but then needs an intrinsically safe position indicator. All LPU-Ex can be delivered with integrated intrinsically safe outlet for position indicator (ia) to solve the problem.

Note! For LPU-Ex with ia-outlet the hole for DPI in LPU must contain a special plug to ensure that flameproof enclosure of LPU-Ex is maintained. This plug is delivered with ia-parts and must always be used for ia-versions.

Position indicator errors

- Fault:**
- ON/OFF position indicator is not functioning correctly:
 - Check the control cable connections.
 - Check the function of the position indicator, measured on the position indicator wire connection. Possibly replace position indicator.
 - Analogue position indicator cannot be calibrated
 - Disconnect the wires from the position indicator, check the adjustment of the potentiometer, and possibly re-adjust the indicator according to the relevant instruction^(*).
 - Analogue position indicator not functioning correctly
For power controlled LPU:
 - Check supply voltage at 4 - 20 mA transmitter which has to be 15 - 27 VDC.
 - Disconnect the wires from the position indicator.
 - Check the adjustment of the potentiometer, and possibly re-adjust the indicator according to the relevant instruction^(*).
 - Check the function of the potentiometer, measured on the indicator.
 - Check the cable entry in cable glands. Shield has to be connected in both ends. If the indicator and cable mounting is OK, replace the printed circuit board (see "Replace Printed Circuit Board" on page 105). Otherwise replace the position indicator.

*) 300-350 Ohm between the "closed" and the "wiper" connection, while the valve is fully closed.

Operating LPU-S 2

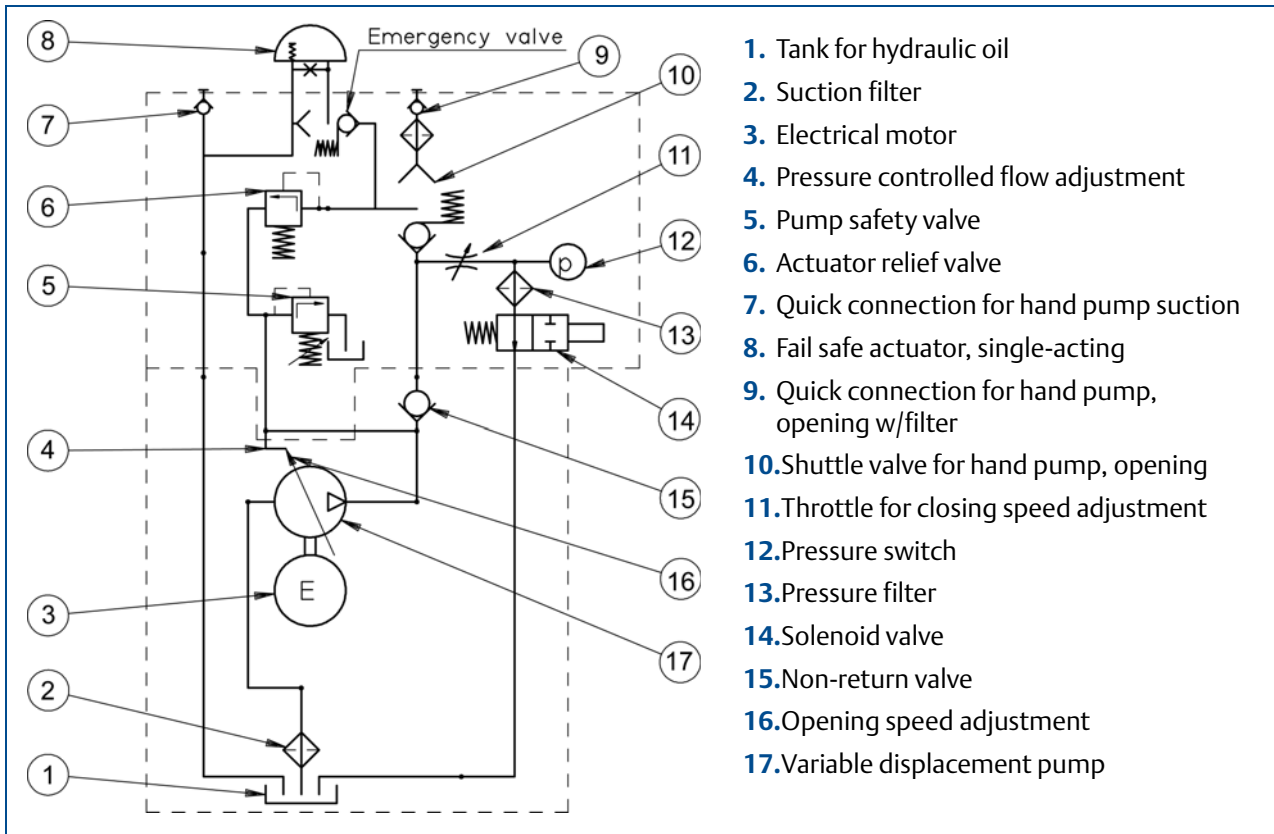

Hydraulic Diagram LPU-S

To open valve

To move the valve towards open, the motor (3) is activated.

The oil is led from tank through the pump and through the non-return valve (15), directly to the actuator B port. To prevent the oil from flowing back to tank, the solenoid valve (14) must be energized. When the valve is fully open, the pressure rises to 150 bar which causes the pump safety valve (5) to open and the oil flows back to tank. The motor is de-energized.

The actuator is now hydraulically locked in position by the solenoid valve.

Safety/Actuator relief valve

In case of a major increase of temperature, the pressure may rise. This will not cause any problems because of the safety valve (6) which will open at approximately 225 bar.

To stop valve in intermediate position

The valve can be stopped (and hydraulically locked) in any intermediate position simply by de-energizing the motor.

If the pressure drops while valve is fully open - due to a minor leakage in the solenoid valve or due to temperature variations -, the pressure switch (12) will detect this. The motor may then be activated

for some seconds in order to keep up the pressure, and prevent the valve from leaving the open position. - This may take place automatically.

Close valve

To move the valve towards closed, the solenoid valve is de-energized. The springs then move the actuator, pressing the oil back from the actuator B port, through the throttle valve (11) and the solenoid valve (14) to the LPU tank.

Note! For power controlled LPU please see also "Operation LPU-S" on page 123.

Operating LPU-D 2a

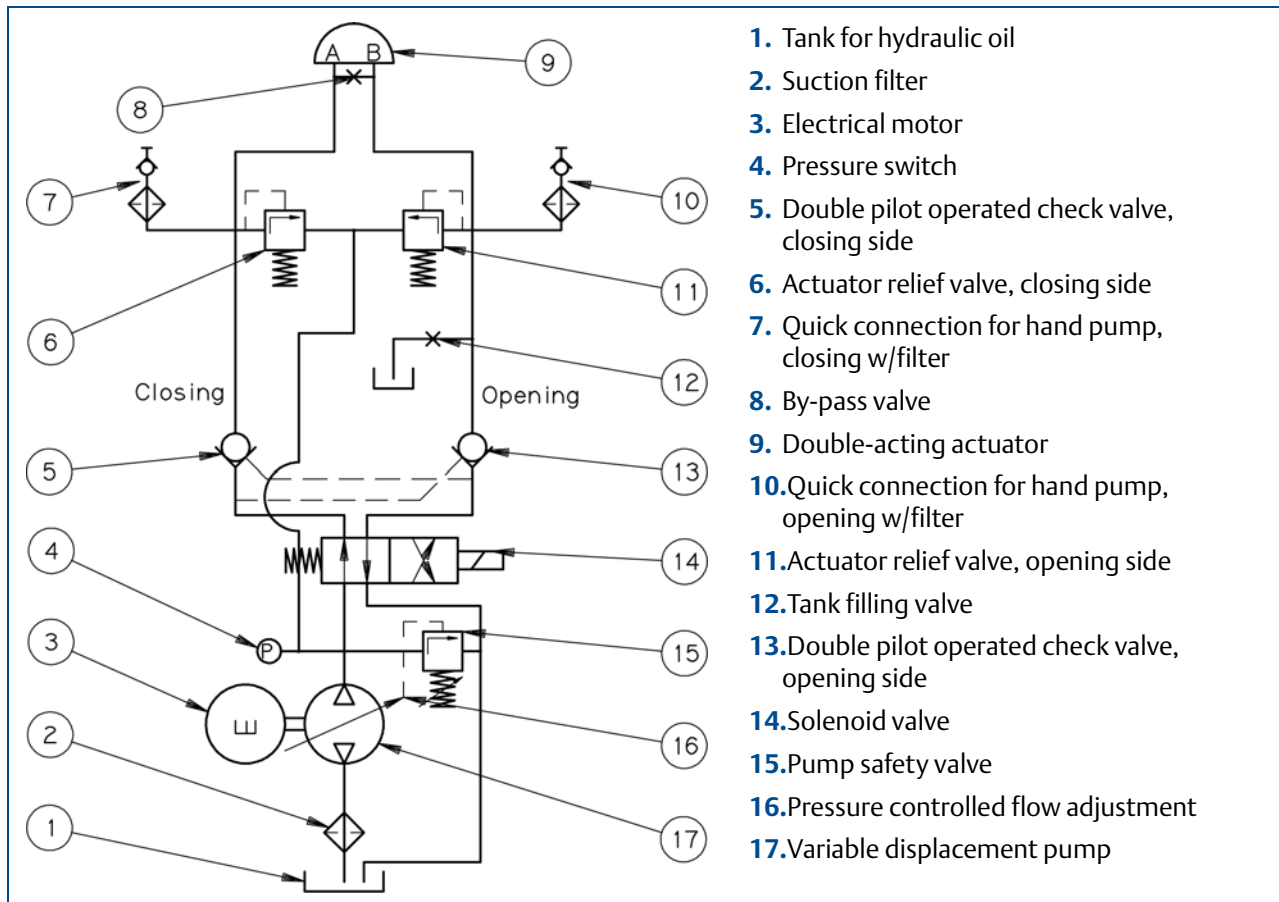

Hydraulic Diagram LPU-D

To open valve

When the motor and solenoid valve are activated the oil is sucked from tank through the suction filter to the pump and pumped through the solenoid valve and the pilot operated check valve (13) to the actuator port B. This causes the actuator to open the valve. The oil from actuator port A flows back through the pilot operated check valve (5) (which is opened by the pressure in the B-line) and returns through the solenoid valve to the tank.

When the valve is fully open, the pressure rises to 150 bar, which causes the pump safety valve to open so that the oil flows back to tank. The motor and the solenoid valve are then de-energized. The actuator is now hydraulically locked in position by the pilot operated check valves.

Safety/Actuator relief valve

In case of a major rise in temperature, the pressure may rise. This will not cause any problems because of the actuator relief valve (6) and (11), which will open at approx. 225 bar.

Close valve

Closing the valve follows exact the same procedure, except that the solenoid valve is not activated which causes the ports A and B to be reversed.

When the motor is running the direction of oil- flow is solely determined by the activation of the solenoid valve.

Note! For power controlled LPU please see also “Operating LPU-D” on page 124.

Emergency Operation of LPU V.2

For all operations: When the hand pump is disconnected and the by-pass valve is closed, the remote control is allowed to operate the system again.

Note! For LPUv.2 emergency operation with hydraulic hand pump, a hand pump unit with reservoir can be used. To avoid overfilling of the LPU, both quick connections have to be mounted.

Note! To close emergency opened actuator by remote, open the actuator first to release shuttle valve and then close.

LPU with LED Position Indicator

LPU (except Ex version) with IP 68 LED indicator will show clear red or green light when the valve is closed respectively open.

Firmly mounted hand pump

With a firmly mounted hand pump the following applies:

Emergency open a fail-open LPU

1. Open by-pass at the actuator or at the firmly mounted hand pump until the valve has reached the desired position. Then close by-pass valve again.
2. If the actuator has been closed by remote control and power is still on “the keep closed” function is activated and the LPU may start up trying to keep the actuator closed. You have to disconnect power or remove close-command before manual operation is started.

The valve will now stay in position until operated with hand pump again or by remote control.

Emergency closing a fail-close actuator

1. Open by-pass at the actuator or at the firmly mounted hand pump until the valve has reached the desired position. Then close by-pass valve again.
2. If the actuator has been opened by remote control and power is still on, “the keep open” function is activated and the LPU may start up trying to keep the actuator open. You have to disconnect power or remove open-command before manual operation is started.

The valve will now stay in position until operated with hand pump again or by remote control.

Emergency closing a fail-open LPU

or

Emergency opening of actuator

1. Turn the directional valve at the hand pump to position “OPEN”
2. Operate hand pump until the valve has reached the desired position.

The valve will now stay in position until operated with hand pump again or by remote control.

Emergency closing of a double acting actuator

1. Turn the directional valve at the hand pump to position “CLOSE”
2. Operate hand pump until the valve has reached the desired position.

The valve will now stay in position until operated with hand pump again or by remote control.

LPU-D

Emergency operation of double acting actuator with key

Actuators that can be opened by emergency operation actuator:
BRC 125 - BRC 500

1. Open the crossover valve by turning counter clockwise.

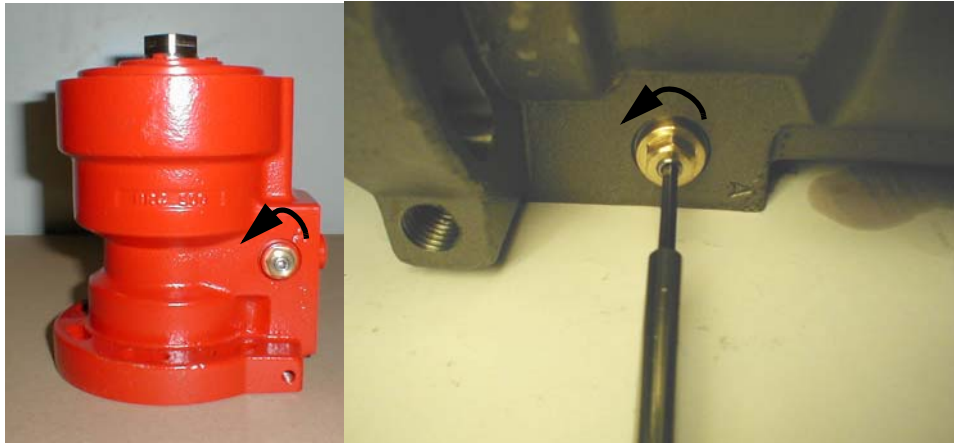

2. Use the emergency operation key on the actuator.



3. Open by-pass valve at the actuator and turn the key counter clockwise to open valve and clockwise to close valve.

4. After emergency operation by key the crossover valve is closed.

Emergency opening of double acting actuator with hand pump

1. Connect hand pump P-line with B-line quick connection at the LPU.

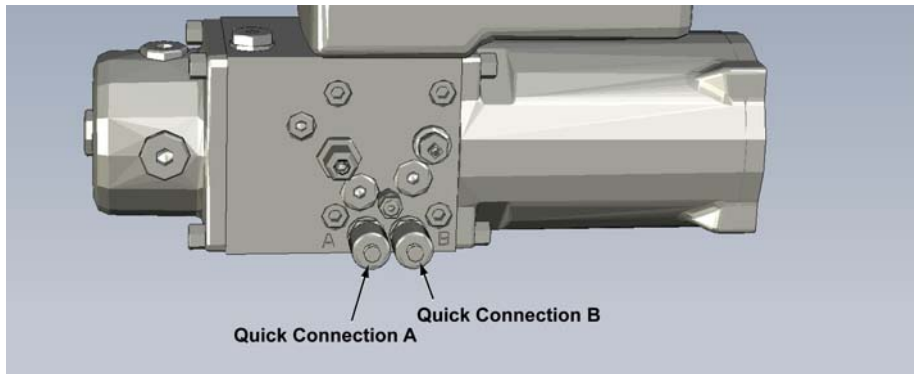

2. Connect hand pump T-line with A-line quick connection at the LPU.
3. Operate hand pump and actuator will open.
4. Disconnect hand pump

Emergency closing of double acting actuator with hand pump

1. Connect hand pump P-line with A-line quick connection at the LPU.

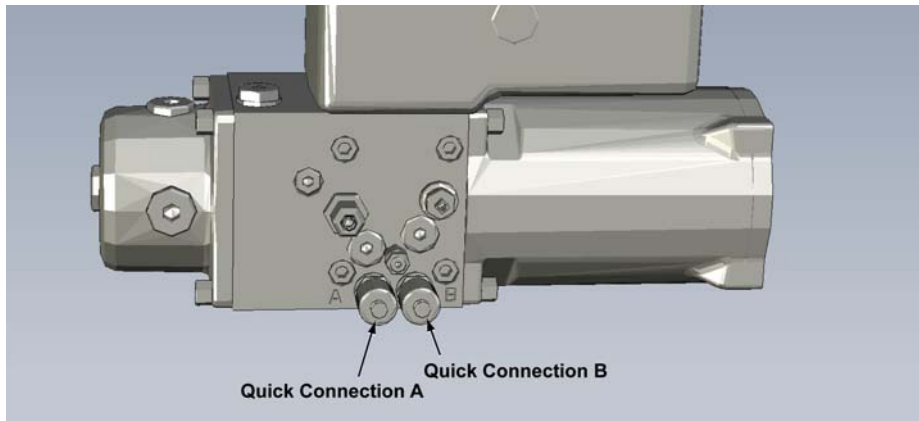

2. Connect hand pump T-line with B-line quick connection at the LPU.
3. Operate hand pump and actuator will close.
4. Disconnect hand pump

LPU-S

Emergency opening of single acting actuator with hand pump

1. Connect hand pump P-line with B-line quick connection at the LPU.

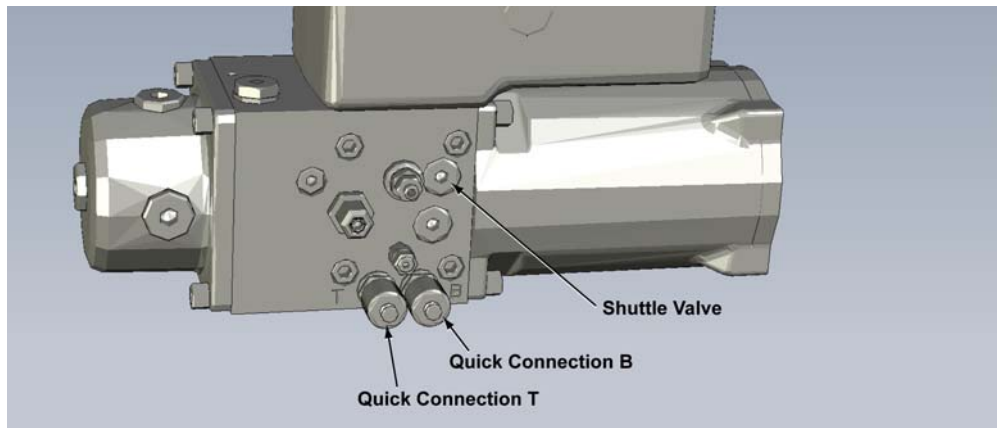

2. Connect hand pump T-line with T-line quick connection at the LPU.
With suction to T and pressure to B the shuttle valve will change over and prevents the oil from flowing to tank.
3. Operate hand pump and actuator will open.
4. Disconnect hand pump

Note! This procedure applies to fail-close actuators.
For Fail-open actuators please contact Emerson Process Management.

Emergency closing of single acting fail-close actuator

1. Open cross-over valve on actuator and let it stay open until the required position is reached.
2. When the valve is fully closed, the shuttle valve will be reset.

Emergency opening of single acting fail-open actuator

1. Open cross-over valve on actuator and let it stay open until the required position is reached.
2. When the valve is fully closed, the shuttle valve will be reset.

Speed adjustment for Actuator on LPU (v.2)

Speed adjustment for double acting actuators

Speed will be adjusted by means of a 3 mm Allen key, see picture below where to adjust. By turning the screw clockwise (fasten screw), the actuator will run slower, turning the screw counterclockwise it runs faster. If the actuator has to run with maximum or minimum speed, the adjustment screw shall only be tightened slightly (max 1.5 Nm).

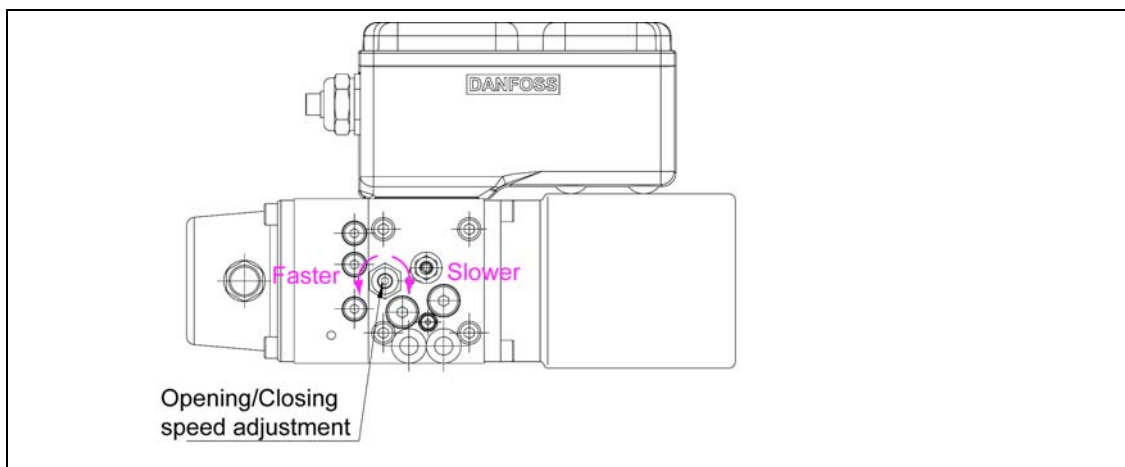

Speed adjustment for single acting actuators

Opening and closing speed will be adjusted by means of a 3 mm Allen key, see picture below where to adjust. By turning the screw clockwise (fasten screw), the actuator will run slower, turning the screw counterclockwise it runs faster. If the actuator has to run with maximum or minimum speed, the adjustment screw shall only be tightened slightly (max 1.5 Nm).

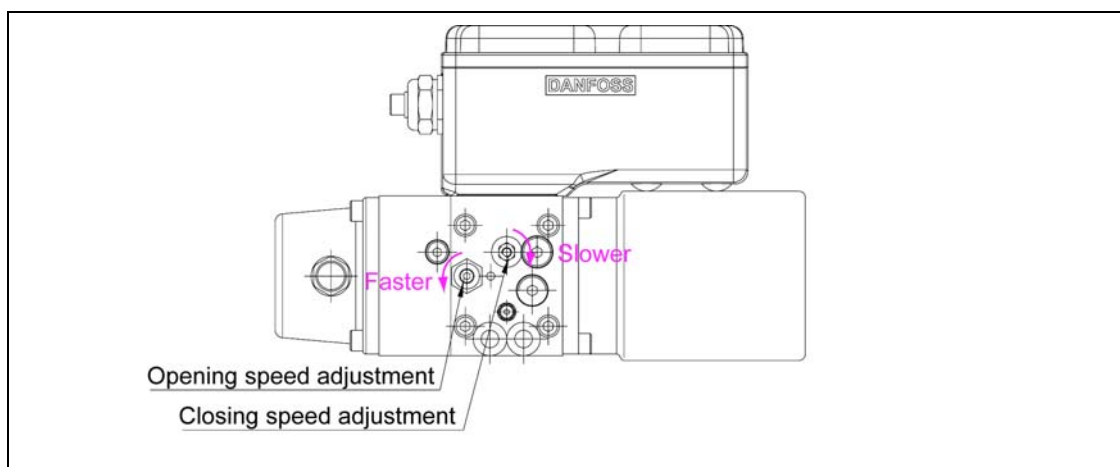

Pump pressure adjustment for LPU



Warning! Parts inside housing of LPU are connected to 230 Volts, please do not touch these parts without power supply securely OFF.

1. The pressure gauge is mounted on quick connection B (nearest to the motor) of the LPU. For LPU-D the adjustment can also be carried out with the pressure gauge on quick connection A, and thus the LPU shall only receive a "Close"-command during adjustment.
2. Adjustment of the pump pressure is carried out with a 5 mm Allen key with ball head. The adjustment screw is placed near the pressure switch (the one near the LPU-front in LPU-D).
3. The pressure has to be set to 150 bar. As there are some tolerances in the system, the pressure might be varying, that's why the pressure is set to 150 bar to assure a running pressure of 135 bar at the actuator. Tightening the screw will rise the pressure, loosening the screw will lower the adjusted pressure.

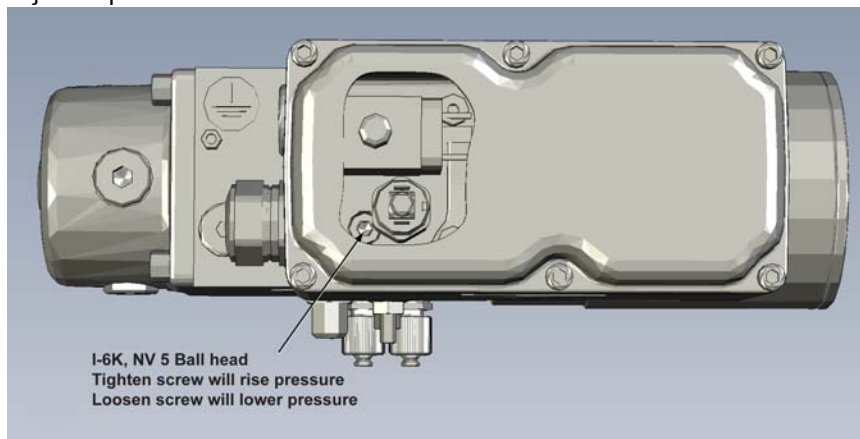

4. **For Power- controlled LPU:** To obtain a longer operating time of the motor than standard 7 seconds, the pressure switch cables to the specific pressure switch (for "B" it is the pressure switch near the pressure adjustment) can possibly be dismantled from the print. These lines are from print card connected to 220 Volt. The motor must be operated for max. 10 minutes.
5. **For P-NET controlled LPU:** To obtain a longer operating time of the motor than standard 7 seconds, the indicator cables to the specific terminal can possibly be dismantled from the print. The motor must be active for max. 10 minutes.
6. When the actuator is in end position, the pressure can be read on the pressure gauge, while the motor is running.
7. The pressure is adjusted to approx. 150 bar. Then the motor is stopped, pressure released and motor is started again for fine adjustment, if any.
8. After final adjustment the pressure gauge is dismantled, and the cables to the pressure switch/indicator are mounted again.

Refill of Oil in LPU

Refilling of oil is normally done when needed. Refill of oil should also be done when parts are changed in LPU or if LPU starts to make special noises at operation.

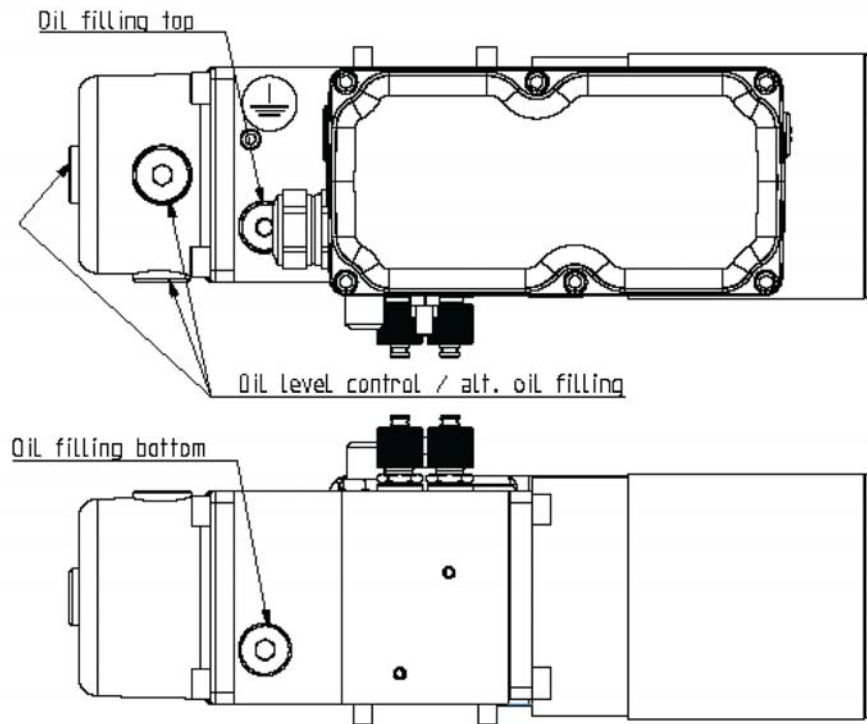

The LPU seen from above and below.

Recommended refill oil

Use an hydraulic oil, as specified for the system. The LPU is normally pre-filled with Shell Tellus T S2 V 32, for deck mounting Shell Tellus S4 VX.

Procedures

LPU without pressurised reservoir using direct level control

1. Remove the breather valve, placed on top or bottom of the LPU or end of oil tank, depending on the LPU mounting direction, see picture on page 87. For LPU-S on BRCF the breather valve might be placed on top of BRCF.
2. Oil level must be max 15 mm below breather valve or plug in LPU.
For LPU-S on BRCF oil level in LPU tank must be above suction pipe at fully opened actuator.
3. If oil level is low, fill the reservoir with hydraulic oil as specified for the system. Oil filling may be done directly through the hole for breather valve or with a hand pump.
4. LPU-S hand pump filling: Apply pressure from hand pump directly to T-quick connection of the LPU. See “LPU-S mounted on BRCF oil filling with hand pump” on page 90
alt.
LPU-D hand pump filling: Open stop valve at front of LPU and apply pressure from hand pump directly to B-quick connection. Close stop valve after filling. See “LPU-D Oil Filling Instruction with hand pump” on page 91.
5. Remount the breather valve.

LPU with pressurised reservoir

1. Oil level is controlled by measuring the distance from cap to piston with closed or fully opened actuator, see drawing next page.
2. If refill is demanded, close the actuator, connect pressure connection from hand pump to T-quick connection for LPU-S, see “LPU-S mounted on BRCF oil filling with hand pump” on page 90 or to B-quick connection for LPU-D, see “LPU-D Oil Filling Instruction with hand pump” on page 91.
3. For LPU-D open by-pass valve at front of LPU.
4. Use hand pump to fill the LPU reservoir. For LPU-D close by-pass valve at front of LPU.
5. When recommended oil level is reached, disconnect hand pump and close the cap at the reservoir with breather valve.
6. Activate the LPU a few times and control oil level again.

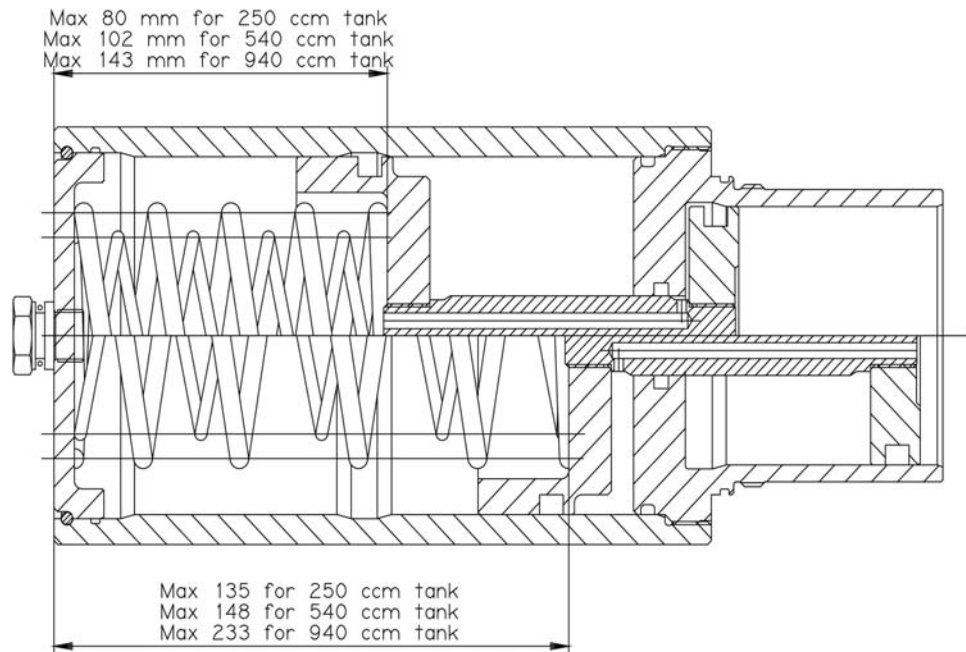

LPU with permanently mounted hand pump

If the LPU is mounted with a permanently mounted hand pump, the oil level control has to be done in the LPU and in the hand pump, as malfunction is possible in an empty hand pump.

LPU-S mounted on BRCF oil filling with hand pump

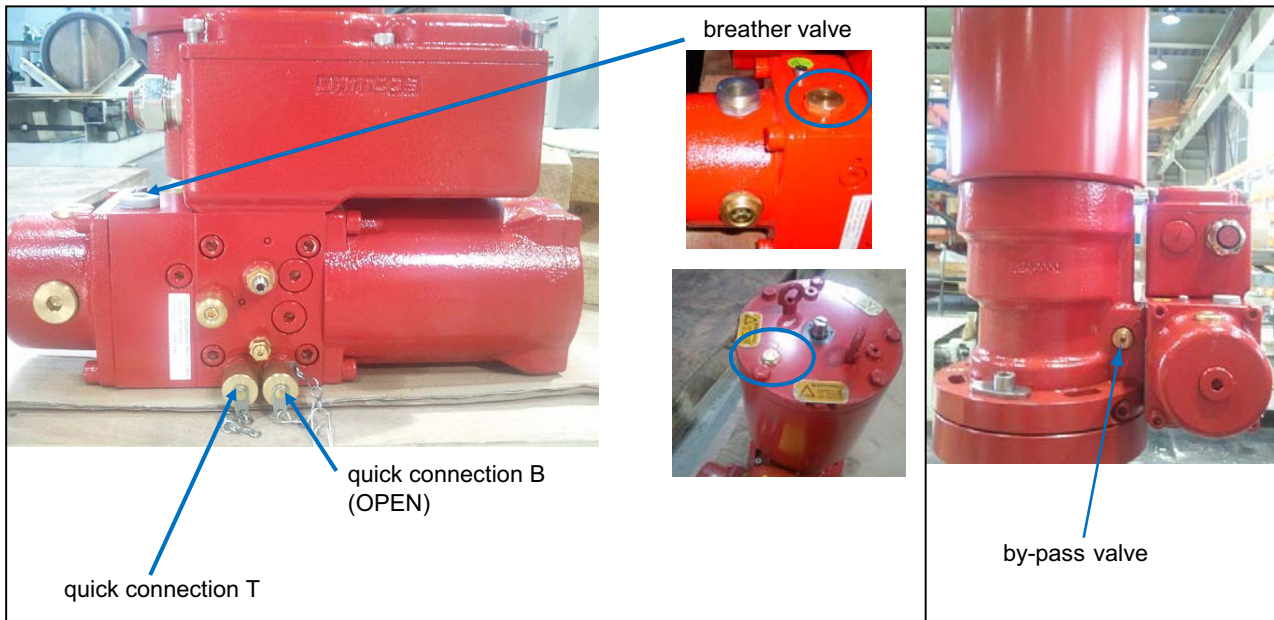

1. Connect hand pump pressure hose to quick connection T.
2. Dismount breather valve or upper-most plug in LPU tank.
3. Apply oil to T-port until tank is full (oil is just about to pour out of tank).
4. Remount breather valve/plug in LPU tank.
5. Dismount breather valve or upper-most plug at top of BRCF.
6. Apply oil to T-port until oil is just about to pour out of BRCF spring chamber.
7. Remount breather valve/plug in BRCF.
8. Disconnect hand pump.
9. Open/close actuator a few times by remote control.

Note! For LPU-S do not operate the directional slide of hand pump to release pressure. The oil inside actuator will flow back to hand pump, but oil will not flow from hand pump to tank line of actuator. Thus oil will be emptied out of LPU if LPU-S is closed by operating the directional slide of hand pump.

10. Resume step 1 to 8 until oil level is stable at correct level.

LPU-D Oil Filling Instruction with hand pump

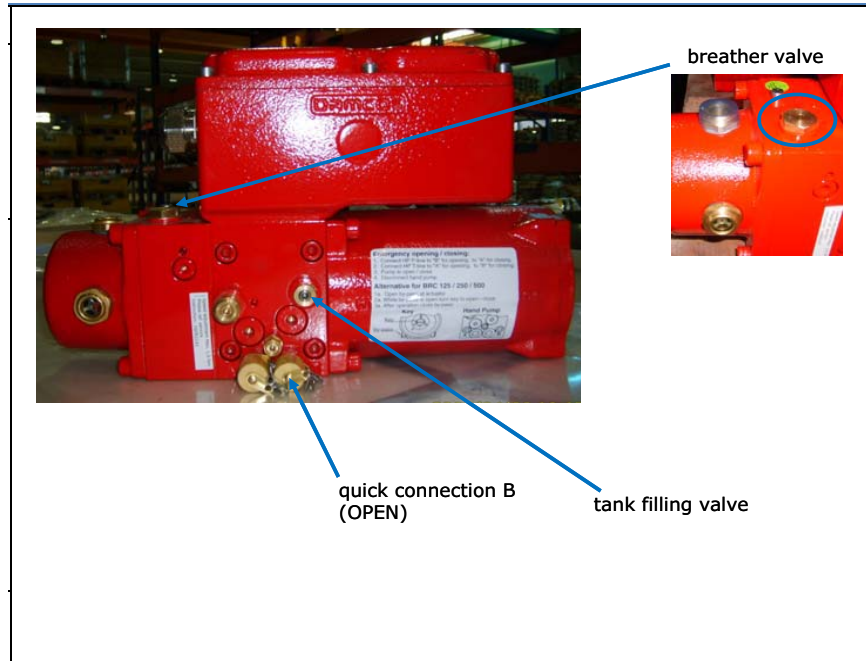

1. Close the actuator fully.
2. Connect the hand pump pressure hose B to quick connection B (open).
3. Open the tank filling valve.
4. Pump the hand pump to fill the LPU reservoir and stop pumping when the oil is pouring out of the breather valve.

Replace Pump in LPU

Note! If permanently mounted hand pump is connected, close stop valves for hand pump if mounted in system.

Replace Pump in LPU

1. Oil tank is emptied by removing plug at bottom of tank or valve block.

2. Remove 4 pcs M8-screw and remove the tank.



3. Valve block with pump is removed from LPU.

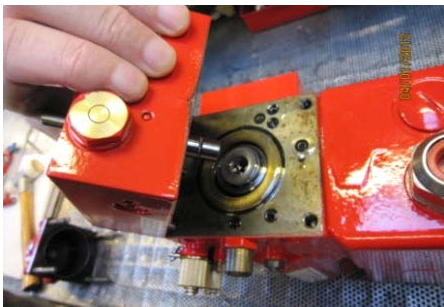

4. Remove suction pipe from valve block by means of Allen key.

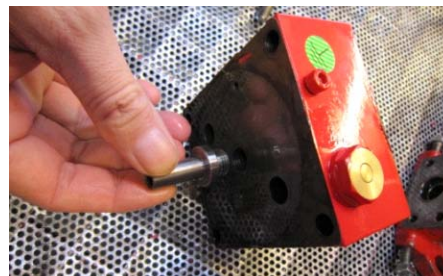

5. Press out the pump stator through suction pipe hole.



6. Remove the rotor.



cont...

Replace Pump in LPU

7. Oil the new stator and place it with slot for pin in same direction as slot in valve block

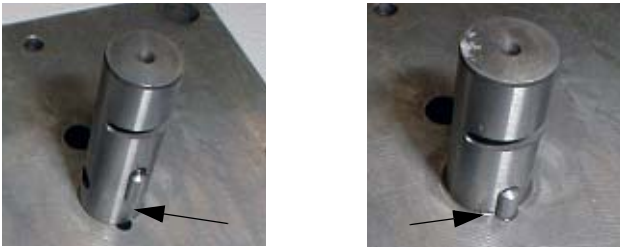

Be sure the small pin is in place on stator!

8. Turn in the stator. When stator is turned to correct rotational position press it down to same level as mounting tool.



9. Check the height of stator. Stator is pressed until extension above valve block surface is 19 mm. This should correlate with the height of mounting tool as of point 8.



It is essential that the height of stator is exactly 19 mm!

10. Check suction pipe filter for contamination. If necessary clean the filter. Mount the suction pipe.



11. Rotor with pistons is placed on stator or in LPU block depending on mounting direction of LPU. Rotor coupling must be placed in same direction as corresponding slot in motor shaft.

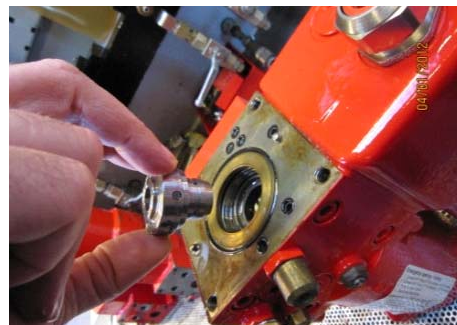

Replace Pump in LPU

12. Check O-rings and exchange them if necessary.

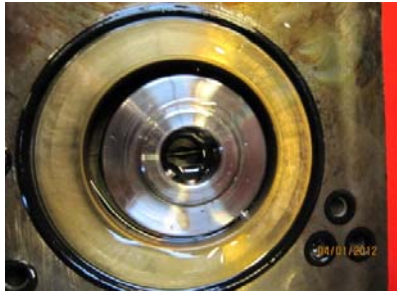

13. Mount the disc on stator.



14. All pistons are kept in place in rotor while valve block with pump is mounted on LPU.



15. Fasten suction pipe.



16. Mount the filter on suction pipe.



17. Mount tank. Screws are cross-tightened.











18. Refill with clean oil. See "Refill of Oil in LPU" on page 87.

19. Open actuator by-pass and start pump for 10-15 sec.
By-passing the actuator ensures de-airing of the pump

20. Control oil level, if necessary replenish. Close by-pass valve and run a full open/close cycle if possible.
Check oil level again.

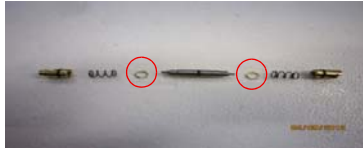
Replace DPCV in LPU

Replace DPCV in LPU	
<p>1. Remove plug.</p> 	<p>2. Use the correct tool or an M2 screw.</p> 
<p>3. Dismount NRV front.</p> 	<p>4. Dismount NRV back.</p> 
<p>5. Remove slide and spring.</p> 	<p>6. Old DPCV:</p>  <p>New DPCV:</p>  <p>2 pcs</p>
<p>7. Mount new DPCV.</p>  	

cont...

Replace DPCV in LPU

8. Mount NRV back.



9. Mount plug at back.









10. Mount NRV in front.



11. Mount plug in front.

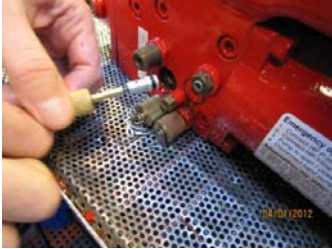

Replace release valve in LPU

Replace release valve in LPU	
<p>1. Remove plug.</p> 	<p>2. Use the correct tool or an M2 screw.</p> 
<p>3. Remove release valve. Note that LPU-D has two release valves, check drawings for exact positions.</p> 	<p>4. Change the valve.</p> 
<p>5. Use tool to mount the valve.</p> 	<p>6. Mount plug.</p> 

Setup new P-net LPU circuit board



Warning! Disconnect the power before changing the circuit board!

Replace Circuit Board in LPU

1. Replace the P-net LPU circuit board. See “Replace Printed Circuit Board” on page 105.

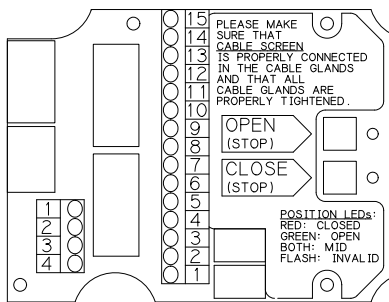

Write down the S/N of the new circuit board.

2. Go to the computer and switch to Project 3.10 using the keyboard; press **ALT** and **TAB** and then select *Project 3.10*.
The window as of point 3 below should be opened.

- 3.

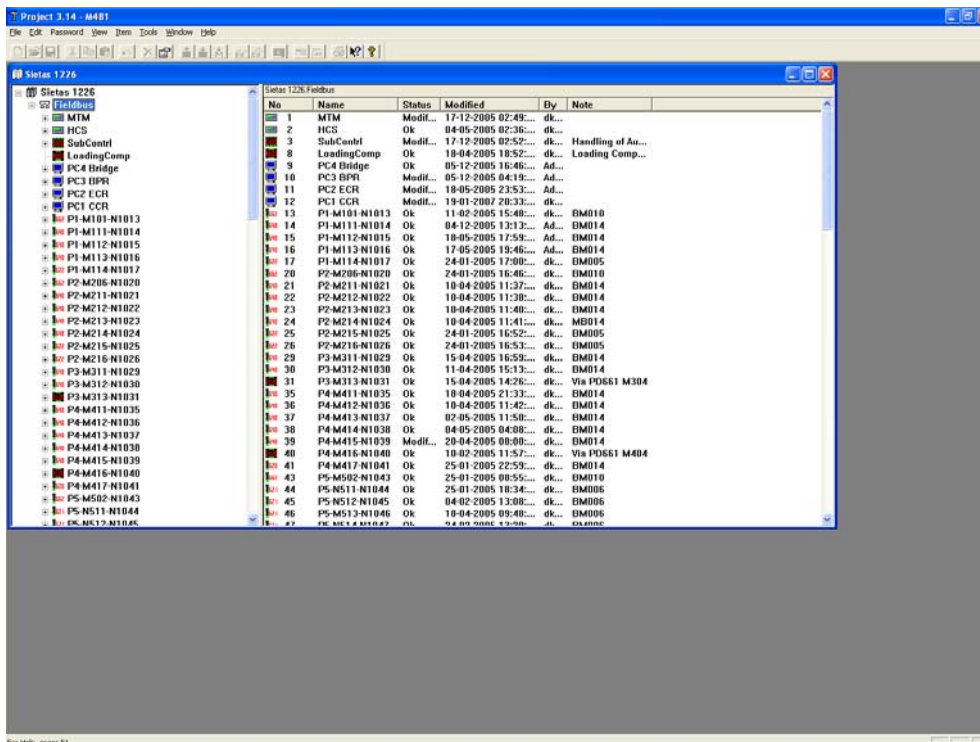

Replace Circuit Board in LPU

4. Select *Password - Enter Password* from the menu.

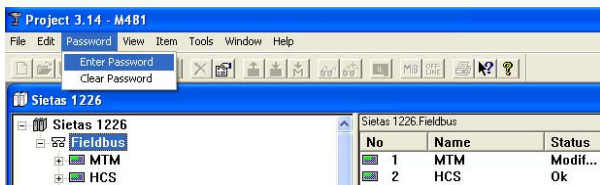

5. Enter password and press OK.



6. Select *Tools - Work offline*. This will set the system online.

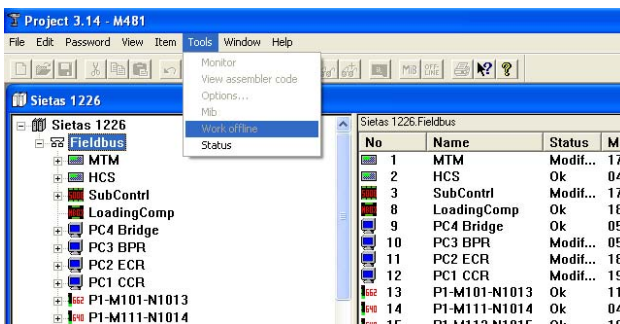

7. Select the LPU/valve where the P-net LPU circuit board has been replaced.

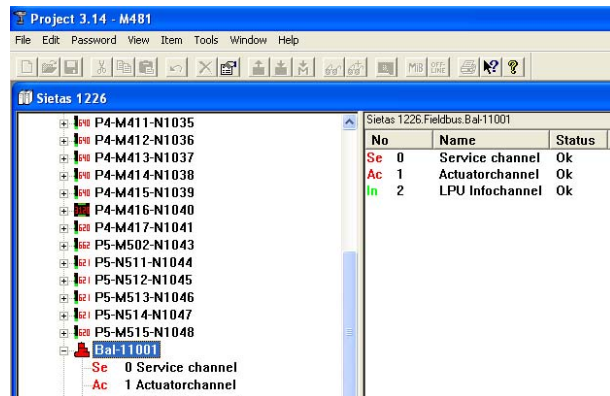

8. Double click on the *Service Channel*.

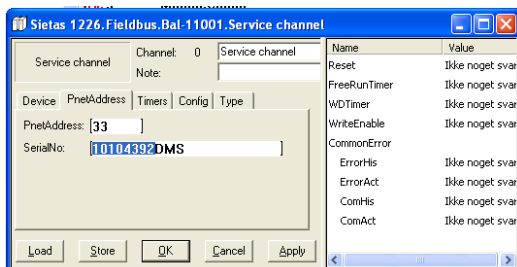

9. Type in the S/N from the new P-net circuit board and select **Store** and **OK**.

10. Right click on the valve name and then select **Store**. This will download the setting for the LPU.

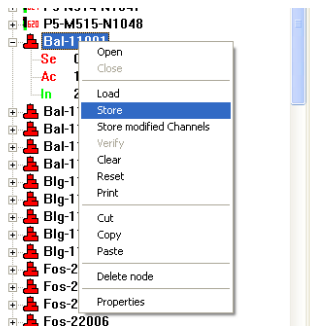

11. The LPU should now work again!

Setup new P-net LPU circuit board in VIEW ver. 3.16



Warning! Disconnect the power before changing the circuit board!

Setup New P-net LPU Circuit Board in VIEW ver. 3.16

1. Replace the P-net LPU circuit board. See “Replace Printed Circuit Board” on page 105.

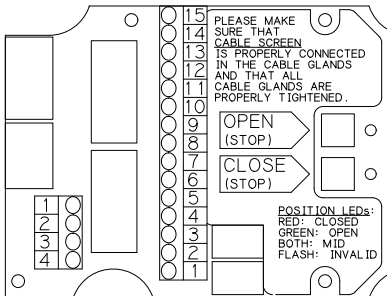

Write down the S/N of the new circuit board.

Go to the computer and select *Status*.



Note! The following procedure should be carried out on one computer only.

2. The following window should be opened.

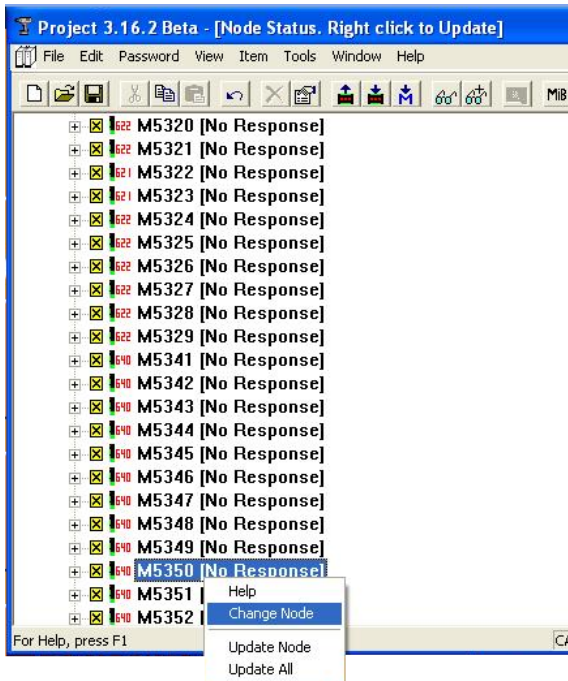

3. In the *Node* status window browse to the faulty module. A fault will be indicated with a yellow square.

Setup New P-net LPU Circuit Board in VIEW ver. 3.16

4. Right click on the module and select Change Node.
The below dialog should appear.

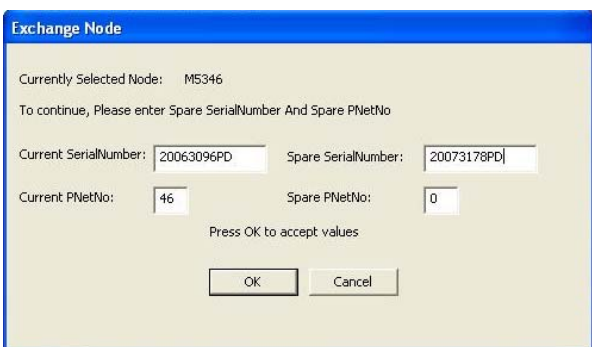

5. Type in the serial number which is found on the new/spare P-net LPU circuit board. For the P-net LPU circuit board the serial number must be followed by "PD". The spare PNetNo is "0".

6. Press OK and if the old module have been replaced then select Yes in the next dialog.

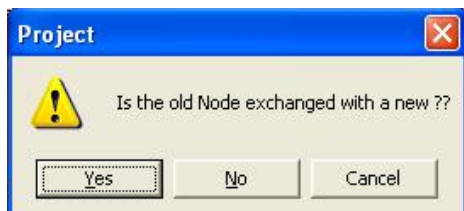

7. Now the LPU should work again from the workstation.

Replace Printed Circuit Board



Warning! Disconnect the power before changing the circuit board!

Replace Circuit Board in LPU

1. Remove cover.



2. Disconnect cable with wire.



3. Remove screws.



4. Remove plug.



5. Remove circuit board.



6. Mount the new circuit board.

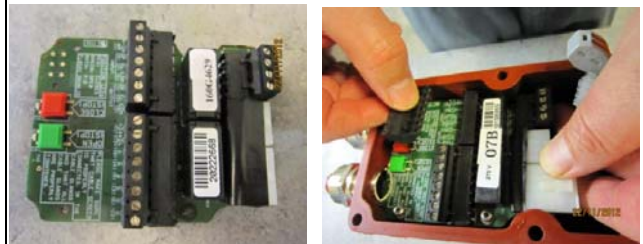

7. Connect cable and wire.



8. Mount the cover.



Replace Solenoid Valve in LPU-D



Warning! Disconnect the power before changing the solenoid valve!

Replace Solenoid Valve in LPU-D

1. Remove cover.



2. Remove screw.



3. Dismount coil.



4. Dismount cover.

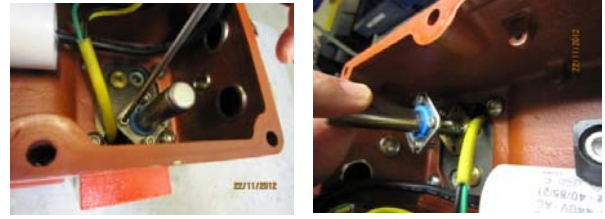

5. Mount new slide and bushing.



6. Make sure that the slide can move easily up and down.



7. Mount cover, coil and screw.

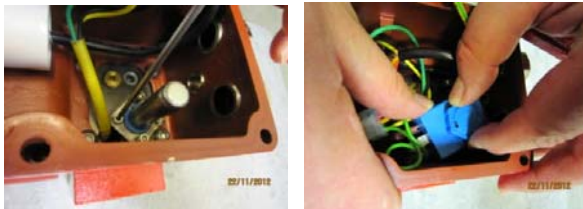

8. Mount cover.



Replace pressure switch



Warning! Disconnect the power before changing the pressure switch!

Replace Pressure Switch in LPU-S

1. Remove cover.



2. Disconnect wires.

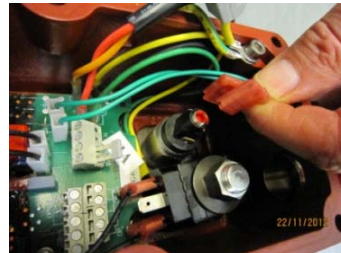

3. Loosen pressure switch with correct tool.



4. Remove the pressure switch.



5. Mount the new pressure switch.

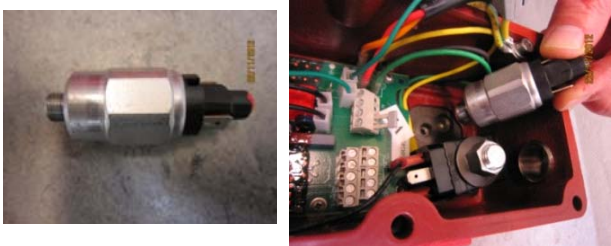

6. Fasten pressure switch with correct tool.



7. Mount the wire.



8. Mount the cover.



LPU Technical Data

This Chapter Describes the Local Power Unit
with Technical Data

Technical Data

Opening/Closing

The LPU is fitted with a variable hydraulic pump enabling you to reduce the flow and thus the actuator speed.

The pump flow and consequently the required motor power is automatically reduced whenever the pump pressure exceeds a certain point. This does not influence the operating time of the valve essentially, as the valve only requires high torque in the end positions. See examples of valve operation.

Valve Operation

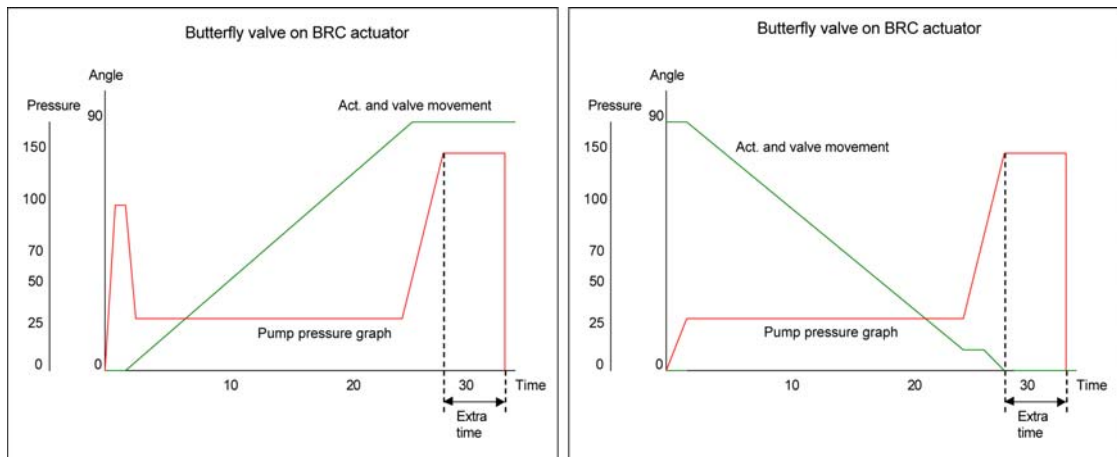

Example of valve operation.

Valve is fully closed	Valve is fully Open
Pressure will be built up until necessary break away torque is obtained (98 bar).	Pressure will be built up until necessary running torque is obtained. (25 bar).
Valve begins to open and only running torque is required from the LPU, pressure is reduced to 25 bar.	Valve begins to touch the valve disc and more pressure/torque is required, LPU starts building up pressure to the reset torque. (67 bar)
Pressure is 25 bar during running of the valve.	Pressure builds up to 67 bar and valve starts end closing.
Valve reaches full open, actuator reaches end position and pressure will start building up.	LPU reaches max. pressure 150 bar, safety valve releases flow to tank.
LPU reaches max. pressure 150 bar, safety valve releases flow to tank.	Valve is completely closed.
The extra time is passed and the motor/- pump stops.	The extra time is passed and the motor/pump stops.
Valve is locked in position by a double pilot operated non-return valve.	Valve is locked in position by a double pilot operated non-return valve.

Hydraulic Specification

Actuator type	Oil displacement ml	Min. operating time (sec.) open/close for LPU-D		
		50 Hz	60 Hz	
BRC 125*	26	1.6	1.3	
BRC 250	50	3.0	2.5	
BRC 500	102	6.1	5.1	
BRC 1000	209	13	10	
BRC 2000	400	24	20	
BRC 4000	800	48	40	
BRC 8000	1600	96	80	
BRC 16000	3100	186	154	
KC 65	21	1.35	1.1	
KC 125	82	4.9	4.1	
KC 250	428	25.6	21.2	
KC 325	793	48	40	
KC 400	1700	102	85	
Actuator type	Oil displacement	Min. operating time (sec.) open for LPU-S		Min. closing time**
		50 Hz	60 Hz	
				N/A
BRCF 125*	26	4	3	1
BRCF 250	50	8	6	2
BRCF 500	102	15	13	4
BRCF 1000	209	31	26	8
BRCF 2000	400	60	50	16
BRCF 4000	800	120	100	32
BRCF 8000	1600	240	200	64
BRCF 16000***	3100	465	388	248
KF 65	21	1.2	1.1	1
KF/KFR 125	82	4.9	4.1	3
KF/KFR 250/150	265	15.9	13.2	10
KF/KFR 250	428	25.6	21.2	17

*) Only bulkhead mounted on LPU. Please note that min. time is calculated value. BRCF spring and value difference can change the actual time.

**) The Standard minimum closing time is listed without QCB and based on an ordinary tank design, except for the BRCF 16000 which only operates with a pressure tank. In case of LPU-S equipped with Pipes to actuator and/or Pressure Tank an extensively increased closing time should be expected, please ask for guidance's.

***) BRCF 16000 should always be equipped with a Pressure tank.

Operating speed

The operating duration can be calculated from the oil displacement of the actuator. The LPU can deliver a flow, smoothly manually adjusted from 250 to 1000 ml/min at 50 Hz.

Example

A BRC 250 can be opened in:
 minimum 50 ml / 1000 ml x 60 sec. = 3.0 sec.
 maximum 50 ml / 250 ml x 60 sec. = 12.0 sec.
 For adjustment please refer to instruction.

Working pressure	135 bar
Relief valve cracking pressure	150 bar
Safety valve pressure	210 ± 40 bar
Max. running time	Up to 10 minutes dependent on ambient temperature
Enclosure rating	IP 68 (3 bar in 24 hours)
Test pressure	225 bar
Ambient temperature	-5°C to 70°C (-25°C to 70°C on request)
Tank volume / utility volume	approx. 300 ml / 120 ml
Weight	18 kg

Electrical Specification

	230 V AC	110 V AC
Power supply	230 V AC 50 or 60 Hz +10% / -20%	110 V AC 50 or 60 Hz ±10%
Starting current	4 A at 20°C	9 A
Running current max.	1.85A at 50 Hz / 2A at 60 Hz	3.5A
Running current at 20°C (220 V 50 Hz)	1.2 A	2.5 A
The solenoid valve in: LPU-S consumes approx. LPU-D consumes approx.	12 W corresponding to 0.07A 9 W corresponding to 0.09 A	0.08 A 0.17 A

Motor is protected against overheating with internal bimetal switch.

Materials

Electrical housing and tank	Cast iron
Slides, etc.	Steel
Screws, sign plate, rivets and bracket	Stainless steel
Seals	NBR/PTFE
Cable glands	Brass/nickel
Hydraulic blocks	Nodular cast iron

Cable Gland

Application	Thread	No.	Min. cable \varnothing	Max. cable \varnothing	Screen	IP	Note
P-Net Control							
230 V	M20x1.5	2	8	15	no	68	
P-NET	M25x1.5	2	13	16	yes	68	
Power Control							
230 V	M25x1.5	1	12½	20½	no	68	
Alternative and additional options							
External position indicator connection	M16x1.5	(1)	8	10	yes	68	LPU is delivered with a plug in the concerned thread
Reducer (thinner cable)	M25/M20	(2)				68	f. cable gland below
P-NET	M20x1.5	(2)	8	11	yes	68	f. thinner P-NET cable

Cable gland LPU-Ex and LPU-Ex-ia

For connection of cables cable gland M12x1.5 has to be rated for Ex-d up to minimum 2000 cm³ enclosure volume for the actual gas class. Make sure that cable diameter fits cable glands and tighten cable glands according to its specifications.

Cables

Shielded 230V supply cable is required for LPU-Ex and LPU-Ex-ia.

Zener barrier LPU-Ex-ia

The internal zener-barrier is built-in in the top cover and holds an Ex-d cable gland. The 24 VDC power supply to the LPU must be connected 0 to ground.

LPU Power Control System

This Chapter describes LPU Power Control System
and Technical Data

LPU Power Control Description

Power controlled LPU has internal control ensuring stop of electrical motor, when the valve has reached end position or if the valve is blocked in intermediate positions.

LPU-S can maintain an open position on a spring actuator by restarting the pump in case of a pressure loss.

The control of the units in the system is carried out with hardwire in star connection from a relay- or PLC substation.

Each LPU is connected to a control console with one cable only and is controlled only by the operating voltage.

In power controlled versions the valve position signals (switches or 4-20 mA loop powered) are led directly to the substation.

Position Indication Signals

The position indicator is built into the pump block with internal wiring from position indicator to the circuit board mounted in the LPU electrical encapsulation.

Potentiometer for analogue position indication, or 2 micro-switches for end-position indication are available.

- For analogue position indication signals, two wires are required.
- For ON/OFF indication signal, one common wire and one wire each for open and for closed signal are required.
- ON/OFF switches are limited to 2.5 VA resistive load. Please refer to separate data sheet
- Direct connection to the potentiometer is also possible. The potentiometer must be used as a 3-wire voltage-divider..

Position indication signal:	Continuous:	4-20mA 24V DC
		2 wire transmitter
	ON/OFF:	Max 2.5 VA switches
Cable: Damcos recommends standard cable, 7 x 1.5 mm ²	Continuous:	Min. 5 x 1.5 mm ²
	ON/OFF:	Min. 6 x 1.5 mm ²
Cable diameter:	Ø 12.5 - 20.5 mm	

Electrical Specification

This unit has to be controlled directly with 115 V AC or 230V AC, 50 or 60 Hz.

A cable e.g. 7 x 1,5 mm² containing motor control and position indicator signal is drawn from the control cabinet to each LPU unit.

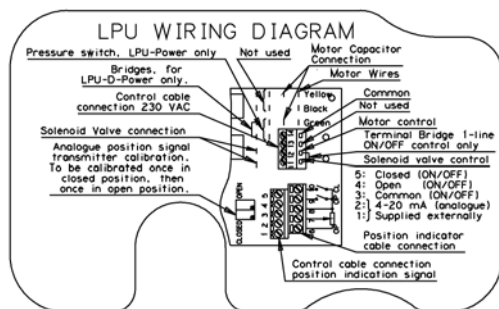

Operation LPU-S

Opening

The LPU-S requires only 2 wires for ON/OFF-operation. When the LPU-S is energized, it opens the valve, runs for 7 sec. extra, and then the motor stops. The valve is kept open by a solenoid valve, preventing the oil from flowing back into the tank.

- If a minor internal leakage over time causes the pressure to fall below the preset pressure switch level, the pump will restart and run for 7 sec., thus keeping up the pressure. This does not affect the position of the valve.
- If you want to obtain intermediate positions, the solenoid valve may be connected and controlled separately.

Closing

When the LPU is de-energized, the solenoid valve opens and the oil flow from actuator to tank, which causes the spring closing actuator to close the valve. This may be used as a fail-safe function.

- If the control system is built up so that the LPU “open” terminal is energized whenever the valve is to be open. An interruption in the power supply will cause the LPU motor to restart as soon as the power is reconnected. This will be avoided by defining the system so that only the solenoid valve is energized. If the valve leaves the required position, the control system must readjust the valve position by re-connecting, the power supply to the “open” terminal.

Electrical LPU-S

The motor/pump starts directly by means of power on “open” terminal.

The timer stops the motor if the pressure has exceeded the pressure switch set point for 7 sec. This circuit ensures high safety on the LPU. Furthermore, a thermal safety is built into the motor.

When the valve is open and the pressure drops below set point, there is an automatic restart.

The solenoid valve will keep the unit in open position as long as the unit has power on.

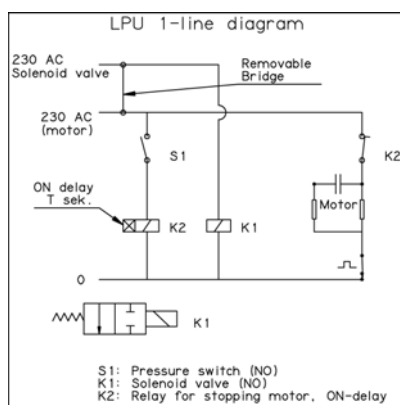

Operating LPU-D

Opening / Closing

LPU-D requires only 3 wires to operate the valve. When the motor is energized, it opens or closes the valve, dependent on the activation of the solenoid valve, runs for a further 7 sec., and then stops. The valve is locked in position by a double pilot operated check valve, preventing the oil from flowing back into the tank.

If you wish to obtain intermediate positions, the motor and the solenoid valve are simply de-energized when the required position has been reached.

Note! To prevent automatic restart after blackout, it is recommended to take away the power for 30 seconds after the valve has reached end position.

Electrical LPU-D

The motor/pump starts directly by means of power on - open or close. If the pressure exceeds 70 bar for 7 sec. the timer stops the motor/pump.

This circuit ensures a high safety on the LPU.

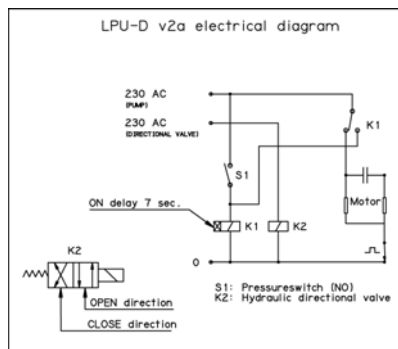

LPU with LED Position Indicator

The LED position indicator in the top cover on the LPU can be powered by:

- Directly via the ON/OFF position indicator (commonly DPI-E), if the signal back to the inputs may be 24VDC respectively 0V.
- From the ON/OFF position indicator outputs in PD527, with the 0VDC connected to the common anode of the LED.
- From customer specified output.

Note! Under all circumstances, 24VDC power to the LED must be available in LPU.

Diagrams for Power Controlled LPU with LED Position Indicator

Option 1 - PD527 controlled power LPU with LED indicator

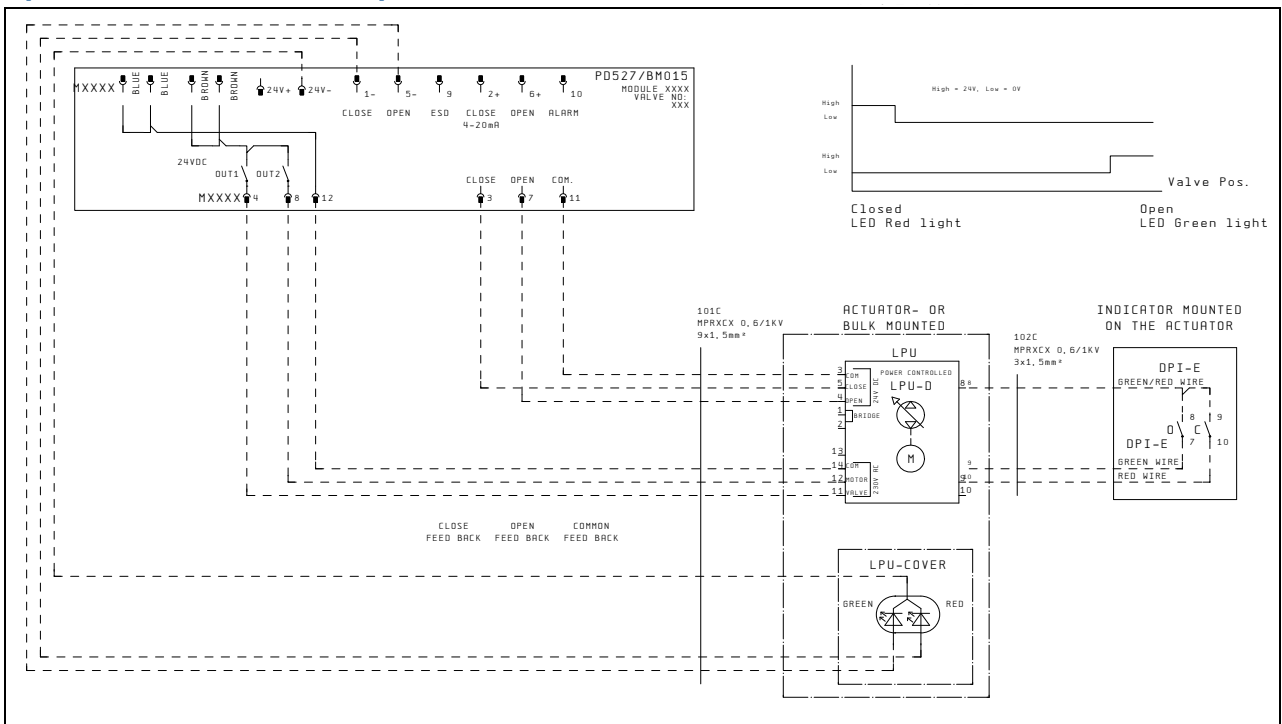

Option 2 - External controlled power LPU with LED indicator

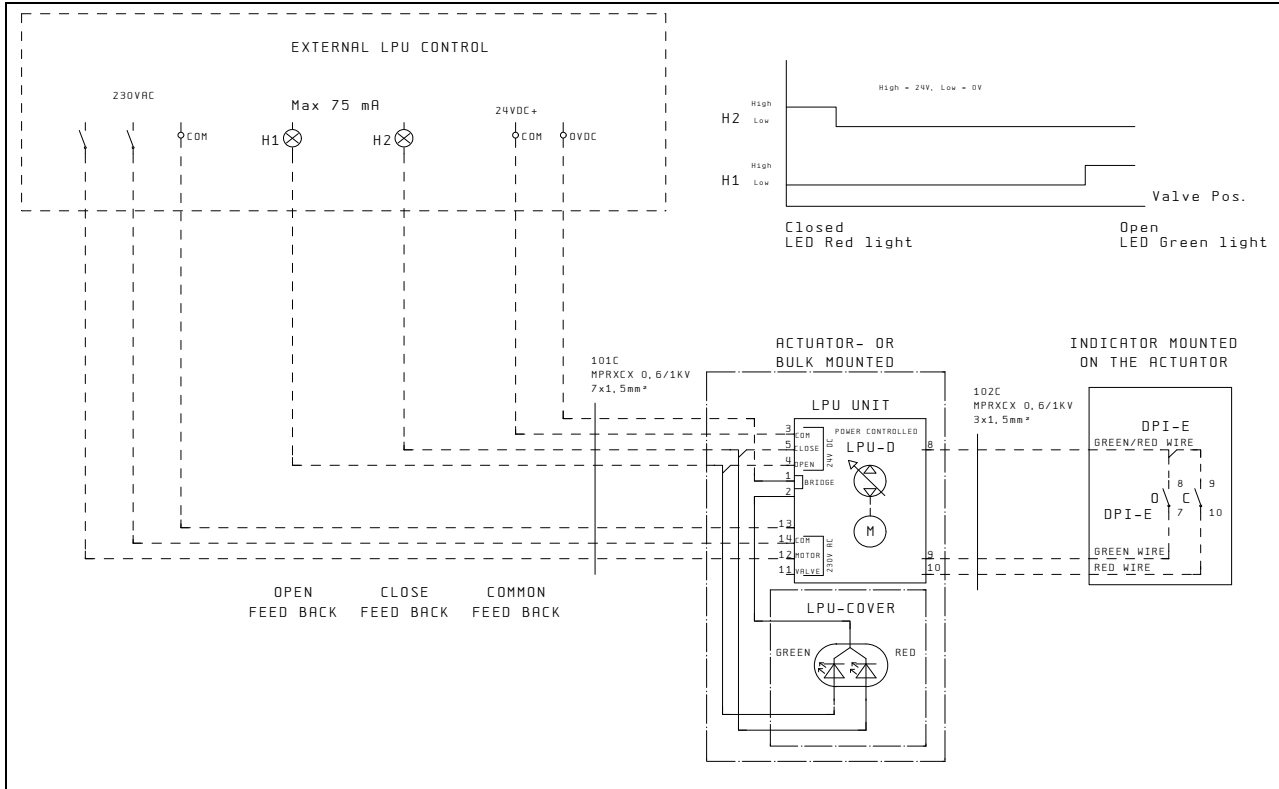

Option 3 - External controlled power LPU with LED indicator

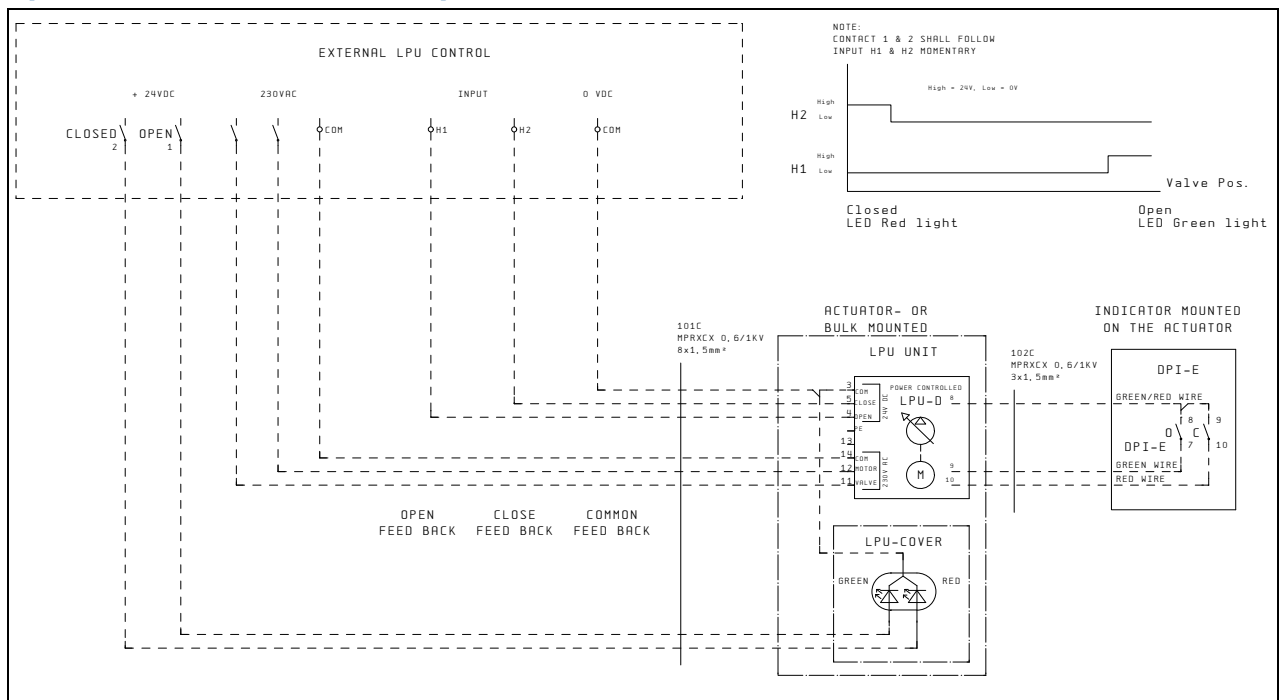

Option 4 - External controlled power LPU with LED indicator

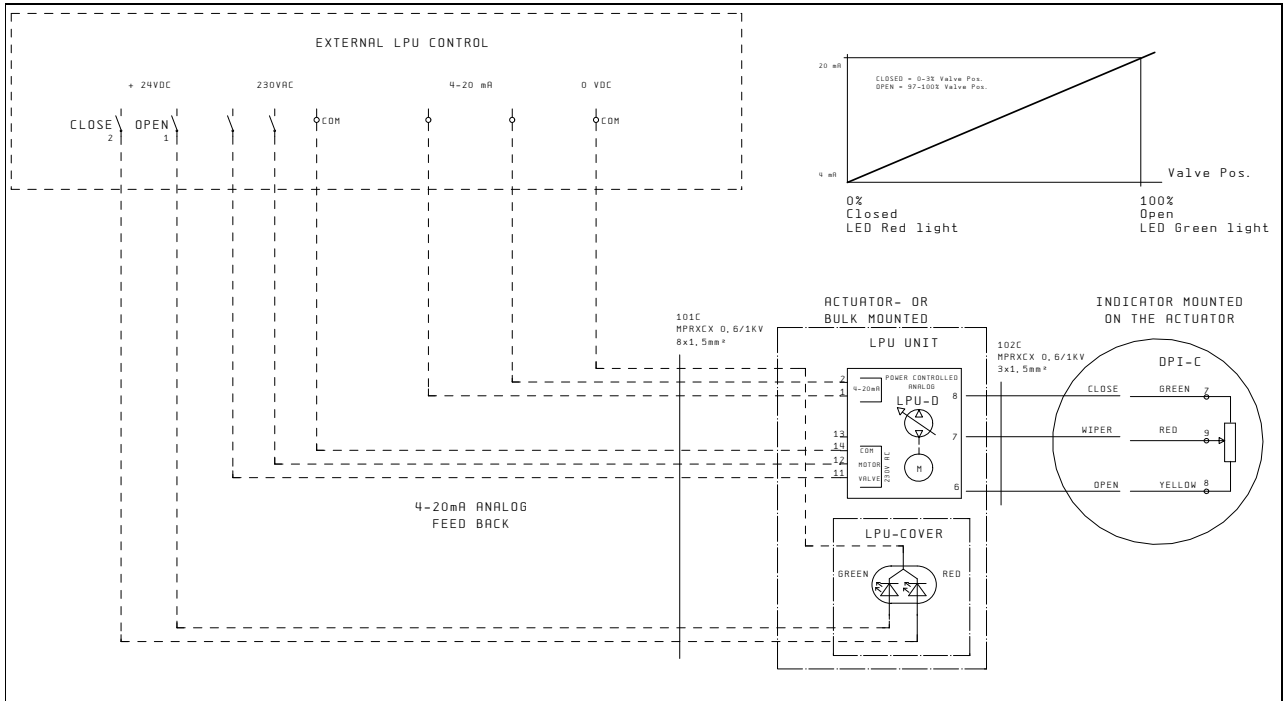

LPU P-NET System

This chapter describes P-NET LPU system
and Technical Data

LPU P-Net Description

The P-NET controlled LPU can be used as a stand-alone unit without being connected to P-NET. In this case it is controlled from external inputs/outputs connected to simple push buttons, lamps or e.g. a PLC (Programmable Logic Controller).

The LPU has built-in internal push-buttons and LEDs to be used for commissioning/test of the unit. Whether the LPU is controlled by the P-NET or by external inputs/outputs, the built-in microprocessor controls and manages the actual control. This ensures an optimal control of the LPU, which is never overloaded.

Position Indication Input Signals

The position indicator is built into the pump block with internal wiring from position indicator to the circuit board mounted in the LPU electrical encapsulation (except for KFR). Potentiometer for analogue position indication or 2 micro-switches for end-position indication are available.

The P-NET LPU is to be configured either to position indicator type ON/OFF or analogue.

LPU with LED Position Indicator

The LED indicator is powered from the 24VDC supply for the LPU electronics, via the internal position indicator output relays in LPU circuit board. LED indicator can be used with either ON/OFF or ANALOG position indicator as desired.

With analog position indicator, the LED will change status over at 3% open valve and 97% open valve.

PCB Diagram for Local Control

Apart from being P-NET controlled, the LPU can simultaneously be controlled locally from e.g. an emergency control. From the connected controllers/workstations it is possible to check whether the LPU is locally operated either by internal or by the external push buttons. It is possible to have an alarm indication activated when the LPU is locally operated.

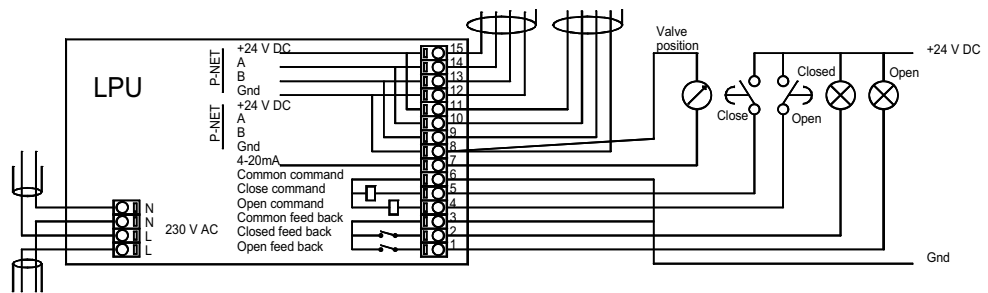

PCB Diagram for Stand Alone Unit

Apart from being controlled by the P-NET the LPU can be used as a stand-alone unit without P-NET but controlled by hardwired inputs/outputs (24 VDC supply must be connected). 24 V DC I/O can be used directly i.e. from PLC. P-NET is applied in connection with end testing, for configuration and test only.

Control follows by means of voltage inputs. Position feedback signal from relay outputs or a 4-20 mA transmitter.

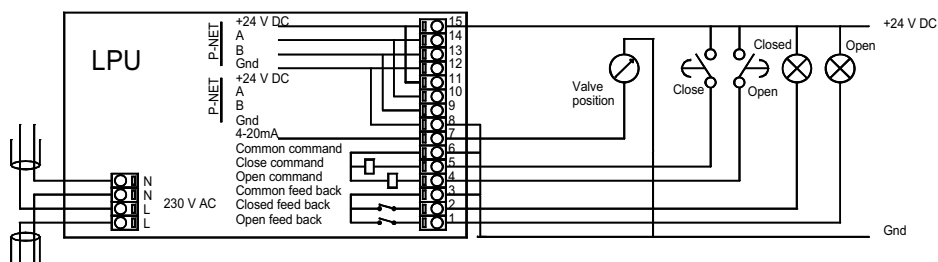

Hydraulic Hand Pump

This Chapter Describes the Hydraulic Hand Pump
with Technical Data

Technical Data

Mounting	Prepared for actuator and bulkhead block interface
Maximum operation pressure	135 bar
Test pressure	225 bar
Maximum hand pump pressure	135 bar
Weight without oil	4.3 kg BRC/F KF version 5 kg KC version
Oil displacement per double stroke	8 cm ³
Oil viscosity range	From 15 to 200 cSt
Temperature range	From -25° to 80° C
Recommended oil filtration	ISO Solid contaminant code 18/15 or NAS 160/10

Material

Housing / Cover	Brass
Spindle / Piston	Brass
Valves	Brass
Screws / Sign plate / Rivet	Stainless steel
Sealings	NBR (Acrylonitrile butadiene)

Hydraulic Diagram for Direct Mounted LPU Handpump

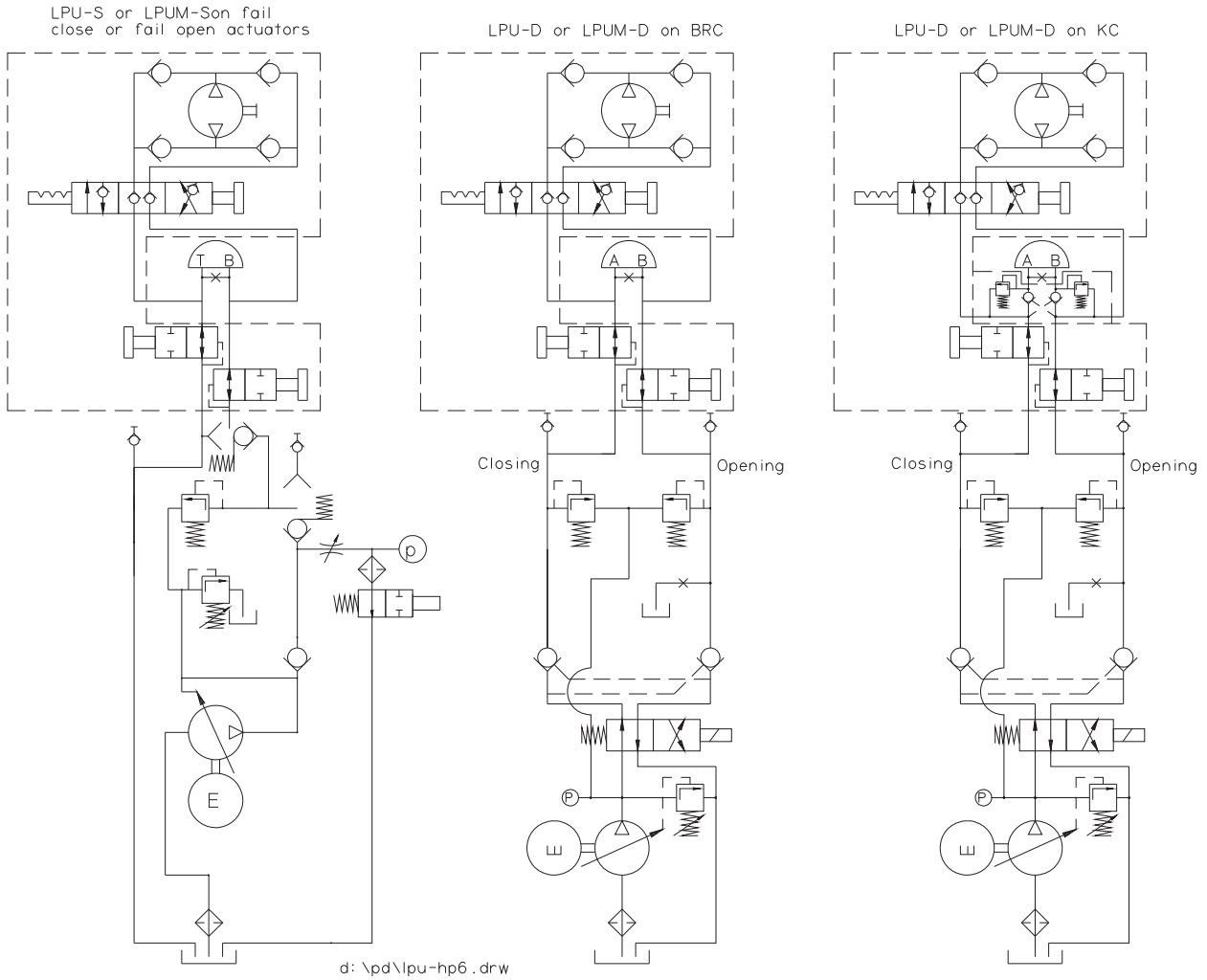

Hydraulic Diagram for Bulkhead Mounted LPU Handpump

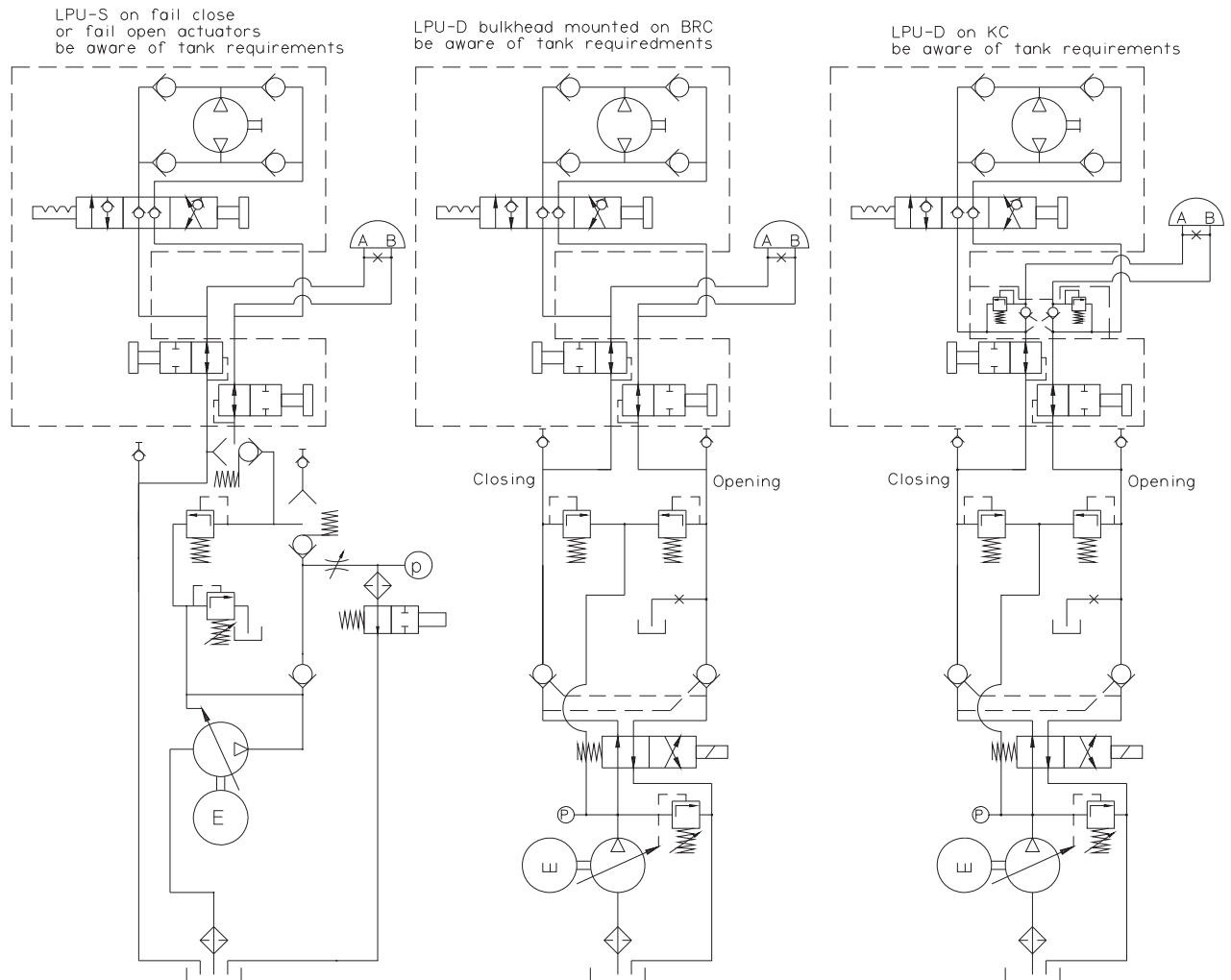

Index

A

- Actuator only running in one direction 53
- Actuator speed adjustment on LPU 83

B

- Bleeder valve positions 14

C

- Check of oil level 88

D

- DPCV replacement in LPU 97

E

- Emergency operation
 - by hand pump giving oil spillage through breather valve 59
 - by hand pump not possible 60
 - by key giving oil spillage through breather valve 59
 - by key not possible, hydraulically locked 59
- Emergency Operation of LPU V.2 77

F

- Fault finding LPU 45
- Firmly mounted hand pump
 - Emergency operation 78

G

- General Considerations 14

H

- Hand pump 137
 - Hydraulic Diagram 138
- High pressure on the port to which oil is led 62
- Hydraulic Diagram for Bulkhead Mounted LPU Hand pump 139
- Hydraulic Diagram for Direct Mounted LPU Hand pump 138

L

- LED Position Indicator 16
- LPU
 - Electrical Specification 115
 - Hydraulic Specification 114

- Materials 116
- Mounting 16
- Operating speed 115
- Technical data 113
- LPU and Optional Equipment 16
- LPU cannot raise pressure after hand pump operation 67
- LPU leaking from bleeder valve 68
- LPU Power Control Description 121
- LPU-D 32
 - Emergency operation 79
- LPU-D not maintaining pressure on actuator 57
- LPU-D-Ex 36
- LPU-D-Ex-ia 40
- LPU-EEx has to be bulk mounted because of too little space or zone 0 at actuator 71
- LPU-Ex motor do not run 70
- LPU-S 20
 - Emergency operation 81
- LPU-S frequently restarting 47
- LPU-S-Ex 24
- LPU-S-Ex-ia 28

M

- Motor "diving" in RPM as spring actuator opens .. 63
- Motor "diving" in RPM in end position 63
- Motor not running 49
- Motor not running on LPU-Ex 70
- Motor not stopping 50
- Motor running for a short time and stops 62
- Motor running hot 49
 - LPU is operating normally 56

N

- Noise from pump
 - at both high and low pressure 55
 - only at high pressure 55
 - only at low pressure 54

O

- Oil and refilling instruction 87
- Oil in electronic connection box 64
- Oil in LPU 87
- Oil level check 88
- Oil spillage from breather valve 64
- Oil spillage through breather valve
 - at emergency operation by hand pump 59

at emergency operation with key.....	59	103	
Oil spillage, generally	64	Solenoid valve not working	52
Operating LPU-D 2a	75	Solenoid valve replacement in LPU-D.....	107
Operating LPU-S 2a.....	73	Speed adjustment for actuator on LPU v.2.....	83
Operating speed.....	115	Speed adjustment for double acting actuators....	83
Overview		Speed adjustment for single acting actuators	83
LPU-D.....	32	Spring actuator	
LPU-D-Ex	36	do not close by emergency hand pump	69
LPU-D-Ex-ia	40	not starting to close	58
LPU-S	20	only partly closing	58
LPU-S-Ex	24		
LPU-S-Ex-ia.....	28		
P		T	
Personal safety	9	Technical Data	137
P-net LPU circuit board setup	101	LPU	113
P-net LPU circuit board setup in VIEW ver 3.16 .	103	Too little tank volume for operating actuator	66
Position indicator errors	72	Trouble-shooting	45
Power controlled LPU	121	U	
Pressure not maintained on actuator via LPU-D ..	57	Unit drawing too much current.....	65
Pressure switch replacement in LPU	109	V	
Printed circuit board replacement in LPU	105	Valve Operation	113
Pump generating		Valve running too slowly	61
noise at high pressure	55	W	
Pump generating noise		Warning Levels	10
at high and low pressure	55	Warning messages	10
at low pressure	54		
Pump not rendering sufficient oil			
at high pressure.....	61		
at low pressure	61		
Pump pressure adjustment for LPU	85		
Pump rendering no pressure	51		
Pump rendering too low pressure	51		
Pump replacement in LPU.....	93		
R			
Recommended refill oil	87		
Refill of Oil in LPU.....	87		
Release valve replacement in LPU	99		
Replace DPCV in LPU	97		
Replace pressure switch in LPU	109		
Replace Printed Circuit Board in LPU.....	105		
Replace Pump in LPU.....	93		
Replace release valve in LPU	99		
Replace Solenoid Valve in LPU-D.....	107		
S			
Safety.....	9		
Setup new P-net LPU circuit board	101		
Setup new P-net LPU circuit board in VIEW ver. 3.16			

Emerson Automation Solutions

Damcos A/S
Aaderupvej 41
DK-4700 Nadstved
T +45 5578 7200
F +45 5578 7272

www.Emerson.com/marine

©2017 Emerson. All rights reserved.

The Emerson logo is a trademark and service mark of Emerson Electric Co. Damcos and the Damcos logotype are trademarks of Damcos A/S, Rosemount and the Rosemount logotype are registered trademarks of Rosemount Inc. Damcos A/S is a member of the Emerson Process Management family of companies. All other marks are the property of their respective owners.

The contents of this publication are presented for information purposes only, and while effort has been made to ensure their accuracy, they are not to be construed as warranties or guarantees, expressed or implied, regarding the products or services described herein or their use or applicability. Standard Terms and Conditions of Sale can be issued by contacting Damcos A/S. We reserve the right to modify or improve the designs and specifications of our products at any time without notice.

Damcos A/S accepts no responsibility for any errors that may appear in this publication.