

⚠ WARNING

If your application is rated as a Hazardous Location, you **MUST** use model ER5050. Models ER5000, ER5020, ER5040, ER5100 and ER5110 are not intended for or rated for use in Hazardous Locations.

TESCOM™ ER5000 Series

User Manual



Do not attempt to select, install, use or maintain this product until you have read and fully understood the *Safety, Installation & Operations Precautions* section of this manual.



SAFETY, INSTALLATION & OPERATIONS PRECAUTIONS



ER5000 — Safety, Installation & Operations Precautions

TESCOM™ ELECTRONIC CONTROLLERS

WARNING



DO NOT ATTEMPT TO SELECT, INSTALL, USE OR MAINTAIN THIS CONTROLLER OR ACCESSORY UNTIL YOU HAVE READ AND FULLY UNDERSTOOD THESE INSTRUCTIONS.

BE SURE THIS INFORMATION REACHES THE OPERATOR AND STAYS WITH THE PRODUCT AFTER INSTALLATION.

DO NOT PERMIT UNTRAINED PERSONS TO INSTALL, USE OR MAINTAIN THIS CONTROLLER OR ACCESSORY.

IMPROPER SELECTION, IMPROPER INSTALLATION, IMPROPER MAINTENANCE, MISUSE OR ABUSE OF THIS CONTROLLER OR RELATED ACCESSORIES CAN CAUSE DEATH, SERIOUS INJURY AND/OR PROPERTY DAMAGE.

OXYGEN SERVICE REQUIRES SPECIAL EXPERTISE AND KNOWLEDGE OF SYSTEM DESIGN AND MATERIAL COMPATIBILITY IN ORDER TO MINIMIZE THE POTENTIAL FOR DEATH, SERIOUS INJURY AND/OR PROPERTY DAMAGE.

Possible consequences include but are not limited to:

- High velocity fluid (gas or liquid) discharge
-  Electrocution
- Parts ejected at high speed
- Contact with fluids that may be hot, cold, toxic or otherwise injurious
- Explosion or burning of the fluid
- Lines/hoses whipping dangerously
- Damage or destruction to other components or equipment in the system

CAUTION

SAFETY PRECAUTIONS

1. Read and understand the user's manual before operating the controller.
2. Inspect the controller and accessories before each use.
3. Operate the unit only under specified environmental conditions.
4. Follow instructions in the manuals for proper wiring.
5. Never connect the controller or accessories to a supply source having a voltage greater than the maximum rated voltage of this controller or accessory.
6. Never connect the controller or accessories to a supply source having a pressure greater than the maximum rated pressure of this controller or accessory.
7. Never use anything but clean dry inert gases or air into the electropneumatic controller.
8. Start up sequence for electropneumatic controllers is:
 - a. Feedback loop must be installed and operational.
 - b. Electrical power should be applied and system setpoint reduced to its lowest pressure output before turning on the pneumatic supply to the controller.
9. Refer to product label (modification specific) for maximum inlet pressures. If this rated pressure cannot be found, contact your local TESCOM representative for the rated pressure prior to installation and use. Verify the designed pressure rating of all equipment (e.g., supply lines, fittings, connections, filters, valves, gauges, etc.) in your system. All must be capable of handling the supply and operating pressure.



ER5000 — Safety, Installation & Operations Precautions

10. Clearly establish flow direction of the fluid before installation of controllers, regulators, valves and accessories. It is the responsibility of the user to install the equipment in the correct direction.
11. Remove pressure from the system before tightening fittings, gauges or components.
12. Never turn controller, regulator or valve body. Instead, hold the controller body and turn fitting nut.
13. If a controller, regulator or valve leaks or malfunctions, take it out of service immediately.
14. Do not modify equipment or add attachments not approved by the manufacturer.
15. Apply pressure to the system gradually, avoiding a sudden surge of fluid or pressure shock to the equipment in the system.
16. Regulators are not shut-off valves. Install a pressure relief device downstream of the regulator to protect the process equipment from operating pressure increases. Shut off the supply pressure when the regulator is not in use.
17. Periodic inspection and scheduled maintenance of your equipment is required for continued safe operation.
18. The frequency of servicing is the responsibility of the user based on the application. Never allow problems or lack of maintenance to go unreported.
19. Read and follow precautions on compressed gas cylinder labels.
20. It is important that you analyze all aspects of your application and review all available information concerning the product or system. Obtain, read and understand the Material Safety Data Sheet (MSDS) for each fluid used in your system.
21. Never use materials for controllers, regulators, valves or accessories that are not compatible with the fluids being used.
22. Users must test under normal operating conditions to determine suitability of materials in an application.
23. Vent fluids to a safe environment and in an area away from employees. Be sure that venting and disposal methods are in accordance with Federal, State and Local requirements. Locate and construct vent lines to prevent condensation or gas accumulation. Make sure the vent outlet is not obstructed by rain, snow, ice, vegetation, insects, birds, etc. Do not interconnect vent lines; use separate lines if more than one vent is needed.
24. Do not locate controllers, regulators, valves or accessories using flammable fluids near open flames or any other source of ignition. Use of Hazardous Location controllers may be necessary to be in accordance with local electric codes.
25. Some fluids, when burning, do not exhibit a visible flame. Use extreme caution when inspecting and/or servicing systems using flammable fluids to avoid death or serious injury to employees. Provide a device to warn employees of these dangerous conditions.
26. Many gases can cause suffocation. Make certain the area is well ventilated. Provide a device to warn employees of lack of Oxygen.
27. Never use oil or grease on these controllers, regulators, valves or accessories. Oil and grease are easily ignited and may combine violently with some fluids under pressure.
28. Have emergency equipment in the area if toxic or flammable fluids are used.
29. Upstream filters are recommended for use with all fluids.
30. Do not bleed system by loosening fittings.
31. Prevent icing of the equipment by removing excess moisture from the gas.
32. Always use proper thread lubricants and sealants on tapered pipe threads.

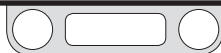

ER5000 — Safety, Installation & Operations Precautions

INSTALLATION

Inspect the controller and accessories for physical damage and contamination. Do not connect the controller or accessory if you detect oil, grease or damaged parts. If the controller or accessory is damaged, contact your local TESCOM™ representative to have the controller cleaned or repaired.

WARNING

Make sure that the components and materials used in the fluid handling system are compatible with the fluid and have the proper pressure rating.

 **Make sure that the components used in the electronic system are compatible with and have the proper voltage rating.**

REPAIR SERVICE

If a controller leaks or malfunctions, take it out of service immediately. You must have instructions before doing any maintenance. Do not make any repairs you do not understand. Have qualified personnel make repairs. Return any equipment in need of service to your equipment supplier for evaluation and prompt service. Equipment is restored to the original factory performance specifications, if repairable. There are flat fee repair charges for each standard model. The original equipment warranty applies after a complete overhaul.

WARNING

SAFE COMPONENT SELECTION

1. Consider the total system design when selecting a component to ensure safe, trouble-free performance.
2. The user is responsible for assuring all safety and warning requirements of the application are met through his/her own analysis and testing.
3. TESCOM may suggest material for use with specific media upon request. Suggestions are based on technical compatibility resources through associations and manufacturers. TESCOM does NOT guarantee materials to be compatible with specific media — THIS IS THE RESPONSIBILITY OF THE USER!
4. Component function, adequate ratings, proper installation, operation and maintenance are the responsibilities of the system user.
5. The user is responsible to be in accordance with all the necessary mechanical and electrical codes required for installation and operation of the system. These requirements include but are not limited to all Hazardous Location controllers.
6. The user is responsible for the selection of the proper model number of the controller that would meet the application's possible hazardous environment or conditions.

WARNING

Do not modify equipment or add attachments not approved by the manufacturer.

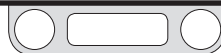

ER5000 — Safety, Installation & Operations Precautions

TESCOM™ REGULATORS

WARNING



DO NOT ATTEMPT TO SELECT, INSTALL, USE OR MAINTAIN THIS REGULATOR, VALVE OR ACCESSORY UNTIL YOU HAVE READ AND FULLY UNDERSTAND THESE INSTRUCTIONS.

BE SURE THIS INFORMATION REACHES THE OPERATOR AND STAYS WITH THE PRODUCT AFTER INSTALLATION.

DO NOT PERMIT UNTRAINED PERSONS TO INSTALL, USE OR MAINTAIN THIS REGULATOR, VALVE OR ACCESSORY.

IMPROPER SELECTION, IMPROPER INSTALLATION, IMPROPER MAINTENANCE, MISUSE OR ABUSE OF REGULATORS, VALVES OR RELATED ACCESSORIES CAN CAUSE DEATH, SERIOUS INJURY AND/OR PROPERTY DAMAGE.

OXYGEN SERVICE REQUIRES SPECIAL EXPERTISE AND KNOWLEDGE OF SYSTEM DESIGN AND MATERIAL COMPATIBILITY IN ORDER TO MINIMIZE THE POTENTIAL FOR DEATH, SERIOUS INJURY AND/OR PROPERTY DAMAGE.

Possible consequences include but are not limited to:

- High velocity fluid (gas or liquid) discharge
- Parts ejected at high speed
- Contact with fluids that may be hot, cold, toxic or otherwise injurious
- Explosion or burning of the fluid
- Lines/hoses whipping dangerously
- Damage or destruction to other components or equipment in the system.

CAUTION

SAFETY PRECAUTIONS

1. Inspect the regulator, valve and accessories before each use.
2. Never connect regulators, valves or accessories to a supply source having a pressure greater than the maximum rated pressure of the regulator, valve or accessory.
3. Refer to product label (model specific) for maximum inlet pressures. If this rated pressure cannot be found, contact your local TESCOM representative for the rated pressure prior to installation and use. Verify the designed pressure rating of all equipment (e.g., supply lines, fittings, connections, filters, valves, gauges, etc.) in your system. All must be capable of handling the supply and operating pressure.
4. Clearly establish flow direction of the fluid before installation of regulators, valves and accessories. It is the responsibility of the user to install the equipment in the correct direction.
5. Remove pressure from the system before tightening fittings, gauges or components.
6. Never turn regulator or valve body. Instead hold regulator or valve body and turn fitting nut.
7. If a regulator or valve leaks or malfunctions, take it out of service immediately.
8. Do not modify equipment or add attachments not approved by the manufacturer.
9. Apply pressure to the system gradually, avoiding a sudden surge of fluid or pressure shock to the equipment in the system.

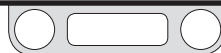

ER5000 — Safety, Installation & Operations Precautions

10. Regulators are not shut-off devices. Install a pressure relief device downstream of the regulator to protect the process equipment from overpressure conditions. Shut off the supply pressure when the regulator is not in use.
11. Periodic inspection and scheduled maintenance of your equipment is required for continued safe operation.
12. The frequency of servicing is the responsibility of the user based on the application.
13. Never allow problems or lack of maintenance to go unreported.
14. Read and follow precautions on compressed gas cylinder labels.
15. It is important that you analyze all aspects of your application and review all available information concerning the product or system. Obtain, read and understand the Material Safety Data Sheet (MSDS) for each fluid used in your system.
16. Never use materials for regulators, valves or accessories that are not compatible with the fluids being used.
17. Users must test components for material compatibility with the system operating conditions prior to use in the system.
18. Vent fluids to a safe environment and in an area away from employees. Be sure that venting and disposal methods are in accordance with Federal, State and Local requirements. Locate and construct vent lines to prevent condensation or gas accumulation. Make sure the vent outlet is not obstructed by rain, snow, ice, vegetation, insects, birds, etc. Do not interconnect vent lines; use separate lines if more than one vent is needed.
19. Do not locate regulators, valves or accessories controlling flammable fluids near open flames or any other source of ignition. Use of Hazardous Location controllers may be necessary to be in accordance with local electric codes.
20. Some fluids when burning do not exhibit a visible flame. Use extreme caution when inspecting and/or servicing systems using flammable fluids to avoid death or serious injury to employees. Provide a device to warn employees of these dangerous conditions.
21. Many gases can cause suffocation. Make certain the area is well ventilated. Provide a device to warn employees of lack of Oxygen.
22. Never use oil or grease on these regulators, valves or accessories. Oil and grease are easily ignited and may combine violently with some fluids under pressure.
23. Have emergency equipment in the area if toxic or flammable fluids are used.
24. Upstream filters are recommended for use with all fluids.
25. Do not bleed system by loosening fittings.
26. Prevent icing of the equipment by removing excess moisture from the gas.
27. Always use proper thread lubricants and sealants on tapered pipe threads.

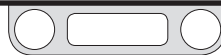

ER5000 — Safety, Installation & Operations Precautions

INSTALLATION

WARNING

Investigate and apply the most recent standards for Hazardous Locations for your area set by ANSI, ISO and OSHA, as well as all electrical codes and fire and safety standards, to determine if your application will require a Hazardous Location model.

CAUTION

Do not open packaging until ready for installation or in a clean environment. Product is cleaned in accordance with CGA 4.1 and ASTM G93, Verification Type 1, Test 1 and Test 2. With periodic verification of cleaning process to MIL-STD-1330D.

WARNING

Make sure that the components and materials used in the fluid handling system are compatible with the fluid and have the proper pressure rating. Failure to do so can result in death, serious injury and/or property damage.

Inspect the regulator, valve and accessories for physical damage and contamination. Do not connect the regulator, valve or accessory if you detect oil, grease or damaged parts. If the regulator, valve or accessory is damaged, contact your local TESCOM™ representative to have the regulator cleaned or repaired.

REPAIR SERVICE

If a regulator or valve leaks or malfunctions, take it out of service immediately. You must have instructions before doing any maintenance. Do not make any repairs you do not understand. Have qualified personnel make repairs. Return any equipment in need of service to your equipment supplier for evaluation and prompt service. Equipment is restored to the original factory performance specifications, if repairable. There are flat fee repair charges for each standard model. The original equipment warranty applies after a complete overhaul.

CAUTION

PROPER COMPONENT SELECTION

1. Consider the total system design when selecting a component for use in a system.
2. The user is responsible for assuring all safety and warning requirements of the application are met through his/her own analysis and testing.
3. TESCOM may suggest material for use with specific media upon request. Suggestions are based on technical compatibility resources through associations and manufacturers. TESCOM does NOT guarantee materials to be compatible with specific media -- THIS IS THE RESPONSIBILITY OF THE USER!
4. Component function, adequate ratings, proper installation, operation and maintenance are the responsibilities of the system user.

WARNING

Do not modify equipment or add attachments not approved by the manufacturer. Failure to do so can result in death, serious injury and/or property damage.





TABLE OF CONTENTS



ER5000 — Table of Contents

Table of Contents

Safety, Installation & Operations Precautions

TESCOM™ ELECTRONIC CONTROLLERS	3
TESCOM REGULATORS	6

Table of Contents

Table of Contents	10
Conventions of This Manual	13
Navigating This Manual	13

Features and Specifications

ER5000 Series Part Numbering System	15
ER5000 Standard Features	15
ER5000 Dimensions – Side Views	16
ER5000 Dimensions – Top and Bottom View.	17
ER5050 Hazardous Location Model	18
Dimensions – Side Views	18
ER5050 Hazardous Location Model	19
Dimensions – Top and Bottom View.	19
ER5000 Specifications	20
Hazardous Location Model (ER5050) Specifications	22
Accessories	24

What's New

New Features	26
Replacing an ER3000 with an ER5000	27

How It Works

The ER5000: How It Works	30
Understanding PID Controllers	31
PID Controllers: Three Components Are Better Than One	32
A Typical PID Control System	33
Tuning a PID Controller	35
Rules of Thumb for PID Tuning	35

The ER5000: Typical Application (Non-Hazardous Location)

Controlling System Pressure	39
A Note Concerning Non-Venting Regulators in Closed Loop Applications	41
Monitoring System Control Limits	42

The ER5000: Control Modes

Internal Feedback Mode	43
External Feedback Mode	43
Cascade Mode	43

Glossary of Terms

Terms Relating to PID Controllers and Controller Tuning	45
Terms Relating to Regulators	52

Getting Started

Before You Begin	58
ER5000 Quick Reference: Jumpers, Terminal Blocks and Wires and LEDs	59
Verify your shipment	60
Additional items not included:	61
Tools you will need for the installation:	61
Additional items and tool you will need for an installation in a Hazardous Location:	61
Verify the configuration of your application.	62
Verify that all operational requirements have been met	63
Verify that all safety requirements have been met	63
Mount the ER5000 on the regulator	64
Connect and verify the power supply	65
Verify the Jumper J6 configuration	68
Connect the USB cable (not supplied with ER5050)	71
Install the ERTune™ program	72
Connect pressure to the system.	73
Start up and tune the system	75

Installation Variations

Before You Begin	77
ER5000 Installation Variations — Wiring Diagrams	78
Terminal Blocks and Wires	79



ER5000 — Table of Contents

Voltage/Current Select Jumpers	80
LED Indicators	81
Power Supply Wiring — All Applications	82
Setpoint Wiring Variations	83
Analog Setpoint Source — Potentiometer	83
Analog Setpoint Source — Current/Voltage	84
Analog Setpoint Source — Passive PC or PLC D/A Card	85
Analog Setpoint Source — Active PC or PLC D/A Card	86
Profile with External Control/Digital Inputs	87
Digital Setpoint Source — RS485 Connection, RS232 to RS485 Converter (TESCOM™ Model #85061)	89
Digital Setpoint Source — RS485 Connection, USB to RS485 Converter (TESCOM Model #82948)	90
Digital Setpoint Source — RS485 Network, RS232 to RS485 Converter (TESCOM Model #85061)	91
Digital Setpoint Source — RS485 Network, USB to RS485 Converter (TESCOM Model #82948)	93
Feedback Wiring Variations.	95
Two Wire Transducer	95
Three Wire Transducer	96
Four Wire Transducer	97
4–20 mA External Feedback, Floating Input, Feedback Signal Monitored by PC or PLC A/D Card	98

4–20 mA External Feedback, Ground Referenced Input, Feedback Signal Monitored by PC or PLC A/D Card	99
Two Wire Transducer, PC or PLC A/D Card Used to Monitor Voltage Produced by the 4–20 mA External Feedback	100
Three Wire Transducer, PC or PLC A/D Card Used to Monitor Voltage Produced by the 4–20 mA External Feedback	101
Four Wire Transducer, PC or PLC A/D Card Used to Monitor Voltage Produced by the 4–20 mA External Feedback	102
Switch Feedback Control to a Second Feedback Source	103
Wiring Variations for Additional Functions	104
Monitoring Additional Analog Inputs	104
Monitoring the ER5000's Internal Sensor Using the Analog Output, 4–20 mA Wiring	105
Monitoring the ER5000's Internal Sensor Using the Analog Output, 0–10V Wiring	106
Digital Outputs	107
Suspend Mode	109
Installing a Hazardous Location Model (ER5050)	110

The ERTune™ Program **111**

ER5000 Software Development Support **196**

ER5000 Communication Requirements	197
ER5000 Software Development Support	197
Windows Programming Examples	198
Accessing the Windows DLL File	199
The TESCOM Protocol.	200

Troubleshooting **202**

Installation.	203
Operation	206
RS485 Communication	216
Using Profiles to Control the ER5000	217

Internal Variables **221**

Table of ER5000 Internal Variables	222
ER5000 Internal Variables	225
ER5000 Setpoint and Feedback Variables	225
ER5000 Configuration Variables	226
ER5000 Inner Loop Tuning Variables	227
ER5000 Outer Loop Tuning Variables	228
ER5000 Analog Input Variables	229
ER5000 Pressure Profile Variables	230

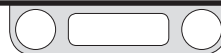

ER5000 — Table of Contents

- ER5000 Single "Puff" Solenoid Control Variable 231
- ER5000 Pulse Mode Variables 231
- ER5000 Analog and Digital Output Variables 232
- ER5000 Pulse Width Modulation (PWM) Control Variables 233
- ER5000 Gain/Offset Variables 234
- ER5000 Control Limit Variables 235
- Control Limits for Specified Signals 235

Certifications and Warranty 236

- Certifications 237**
- Hazardous Locations Special Requirements and Certifications for the ER5050 238**
- LIMITED WARRANTY 240**

Appendix A: Setting up the ERTune™ Program on Windows 8 PCs 241

- Installing the .NET Framework 3.5 242**
- Installing the ER5000 Device Driver 244**

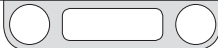

ER5000 — Table of Contents

Conventions of This Manual

refer to
page 41

Text formatted as gray and italic denotes a clickable cross reference. Clicking this text moves you to the referenced page in the manual. After reading the referenced material, you can return to your original page by clicking the **BACK** button at the bottom of the page.

Cross references link to figures, tables and section headings. Also, words which are described in the Glossary are cross referenced to their Glossary description the first time they appear in the body text.

Click the Add
Variable button

Text formatted as gray and narrow denotes a part of the user interface, either of the Windows operating system or the ERTune™ program. This includes menu items, buttons, windows, screens, commands and onscreen instructions.

 **NOTE**

Paragraphs highlighted by the **NOTE** icon contain information that should be given particular attention.

 **IMPORTANT!**

Paragraphs highlighted by the **IMPORTANT!** icon contain information that references specific requirements of your operating system.

 **CAUTION**

Paragraphs highlighted by the **CAUTION** icon contain information that must be followed to maintain a safe and successful operating environment.

 **WARNING**

Paragraphs highlighted by the **WARNING** icon contain information about practices or circumstances that can lead to personal injury or death, property damage or economic loss.

Navigating This Manual

Clicking any item in the **Table of Contents** moves you to that page in the manual.

You can also open the **Bookmarks panel** at any time to access an interactive set of links based on the Table of Contents.



Clicking the **PREVIOUS** button moves you to the previous consecutive page in the manual.



Clicking the **NEXT** button moves you to the next consecutive page in the manual.

BACK

Clicking the **BACK** button moves you to the previously viewed page in the manual. This button returns you to your original page after you click a cross reference.

Microsoft®, Windows®, Windows XP®, Windows Vista®, Windows 7®, Windows 8® and Windows® Explorer® are registered trademarks of Microsoft Corporation in the United States and other countries.





FEATURES AND SPECIFICATIONS



ER5000 Series — Features and Specifications

ER5000 Series Part Numbering System

As Figure 1 indicates, several base styles are available, including a compact OEM model for tight spaces where the NEMA 4 enclosure isn't needed. Please consult with your TESCOM™ representative for special modifications or requirements.

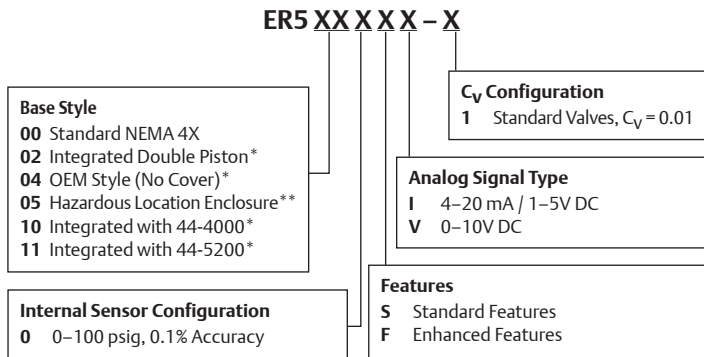

* Contact the factory for dimensions and specifications of these ER5000 Series models.

** Click this link to view all Hazardous Location certifications for ER5050 model.

Figure 1: Breakdown of the ER5000 Part Number

ER5000 Standard Features

- USB and RS485 communications
- USB cable with integrated strain relief***
- 1/8" NPTF Inlet and Exhaust Ports
- 1/2" SAE controlled Outlet Port
- Adaptor fitting 1/2" SAE x 1/8" NPTF
- Maximum inlet pressure = 120 psig / 8.2 bar***
- 0–100 psig / 0–6.9 bar internal sensor
- ERTune™ program for Windows XP, VISTA, Windows 7 and Windows 8

IMPORTANT! Windows 8 users: In order to maintain compatibility with previous Windows operating systems, the ERTune™ program uses the .NET Framework 3.5, which is not installed by default in Windows 8. If you are using Windows 8, you will need to download and install .NET Framework 3.5 before installing the ERTune™ program. You may also need to disable Driver Signature Enforcement to install the ER5000 driver. We have provided step-by-step instructions for both these tasks in Appendix A: Setting up the ERTune™ Program on Windows 8 PCs.

*** These features do not apply to ER5050 Hazardous Location model.



ER5000 Series — Features and Specifications

ER5000 Dimensions – Side Views

Contact the factory for dimensions and specifications of models ER5020, ER5040, ER5100 and ER5110. Refer to the ER5000 Series Part Numbering System.

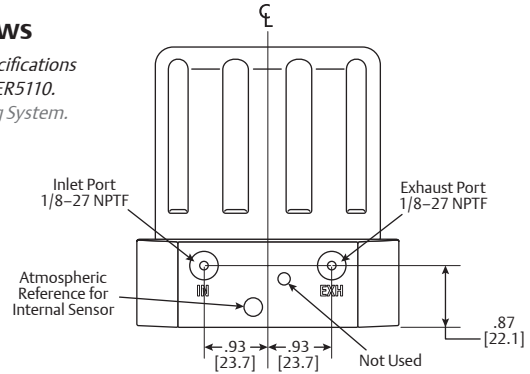
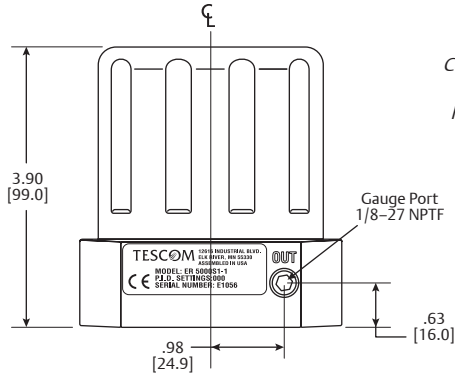

All dimensions are called out in inches [millimeters]

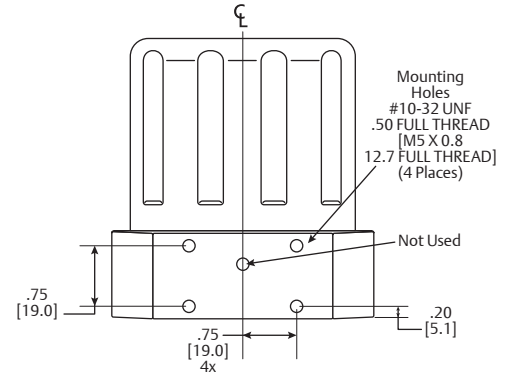
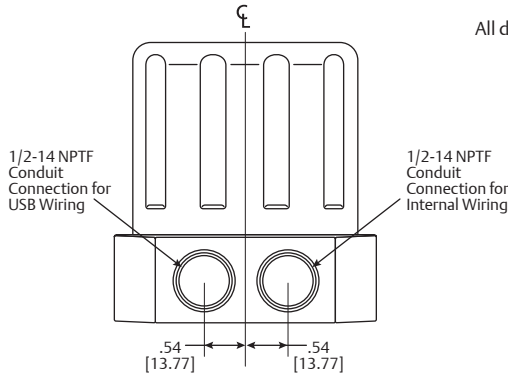

ER5000 Series — Features and Specifications

ER5000 Dimensions – Top and Bottom View

Contact the factory for dimensions and specifications of models ER5020, ER5040, ER5100 and ER5110. Refer to the ER5000 Series Part Numbering System.

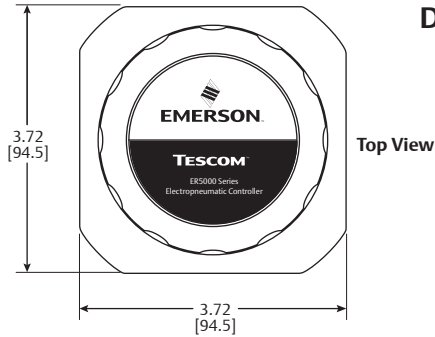

All dimensions are called out in inches [millimeters]

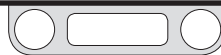
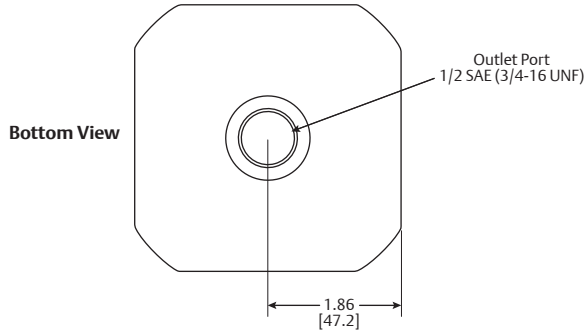

ER5000 Series — Features and Specifications

ER5050 Hazardous Location Model Dimensions – Side Views

Contact the factory for dimensions and specifications of models ER5020, ER5040, ER5100 and ER5110. Refer to the ER5000 Series Part Numbering System.

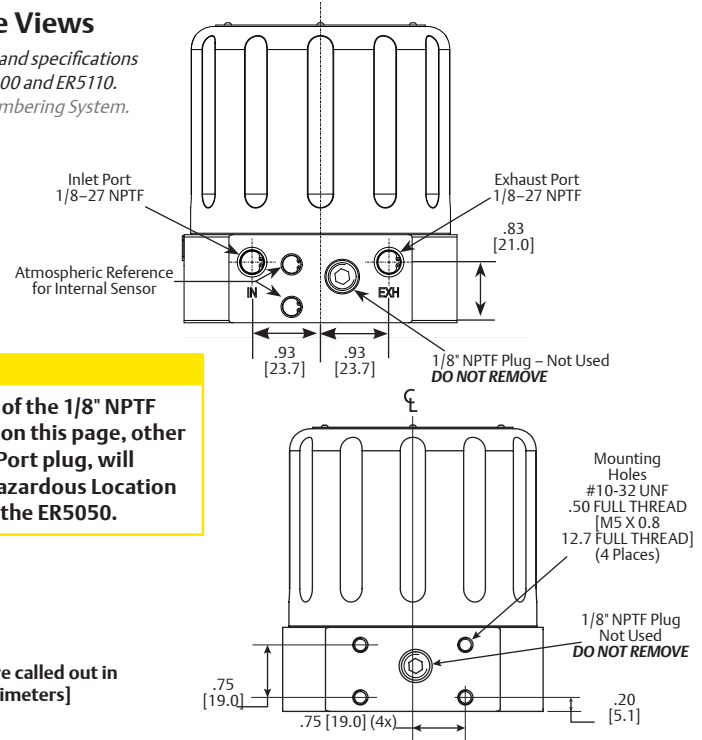
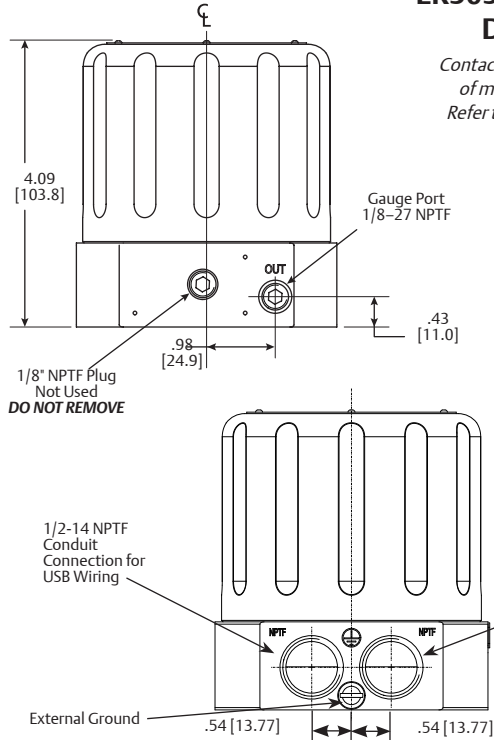

CAUTION
Removal of ANY of the 1/8" NPTF plugs called out on this page, other than the Gauge Port plug, will invalidate the Hazardous Location certification for the ER5050.

All dimensions are called out in inches [millimeters]

ER5000 Series — Features and Specifications

ER5050 Hazardous Location Model Dimensions – Top and Bottom View

Contact the factory for dimensions and specifications
of models ER5020, ER5040, ER5100 and ER5110.
Refer to the ER5000 Series Part Numbering System.

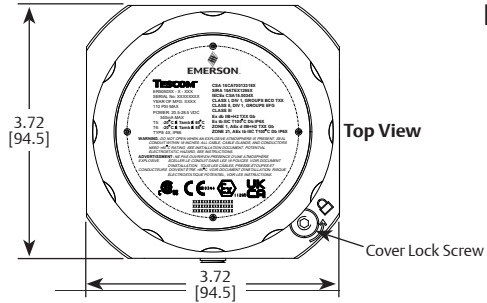

All dimensions are called out in
inches [millimeters]

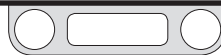
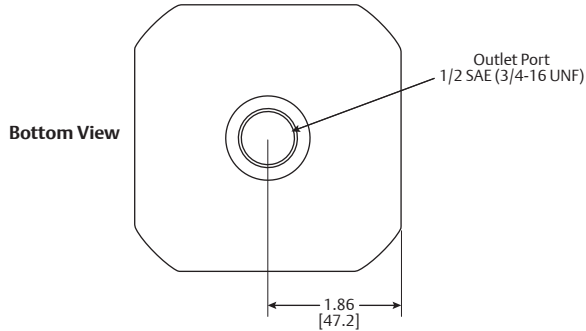

ER5000 Series — Features and Specifications

ER 5000 Specifications

Contact the factory for dimensions and specifications of models ER5020, ER5040, ER5100 and ER5110. Refer to the ER5000 Series Part Numbering System.

Enclosure

Type 4X, IP66. If the two 1/2-14 NPTF ports are unused, properly seal with a plug.

CE Approved Wiring Instructions

Use shielded, twisted pair cable.

Weight

3.1 lbs / 1.4 kg

Media

Supply pressure must be clean, dry inert gas or instrument grade air that meets the requirements of ISA Standard 7.0.01. Use of an in-line filter that meets the requirements of ISA standard 7.0.01 and is less than 40 microns and as small as 10 microns, is highly recommended to prevent damage to the solenoid valves. Moisture should be kept to a minimum.

Ports

Conduit: 1/2" NPTF
Pneumatic: 1/8" NPTF — Inlet, Exhaust and Gauge Ports
1/2" SAE — Controlled Outlet Port

Power Requirement

Voltage: 24V DC (22V DC to 28V DC)
Current: 340 mA max, 180 mA nominal

Environment

Temperature: -30°C to 75°C (dry Nitrogen supply gas)
5°C to 75°C (shop air)
Pressure: 28" to 32" Hg / 71 mm to 762 mm Hg
Humidity: To 100% R.H. (non-condensing) @ 0°C to 75°C.

Inlet Pressure

Minimum: Outlet pressure + 1 psig
Maximum: 120 psig / 8.2 bar
Typical: 110 psig / 7.5 bar

NOTE Response time is affected by input pressure.

Sensor Update Rate

25ms (rate of sensor reading and processing task)

USB Communication Interface

USB: 2.0
Maximum cable length: 15 ft / 4.5 m
Connector: Mini-B



ER5000 Series — Features and Specifications

ER 5000 Specifications (cont.)

RS485 Communication Interface

Networking: Up to 32 controllers on one network
Maximum cable length: 4000 ft / 1219 m
Baud rate: 9600

Flow Rate

C_v : 0.01

 **NOTE** The flow rate can be increased using a booster regulator.

Accuracy

Room temp: 0.1% of span maximum

Response Time

Rise Time: 257ms — 10 psig to 90 psig / 0.7 bar to 6.2 bar
Fall Time: 552ms — 90 psig to 10 psig / 6.2 bar to 0.7 bar

 **NOTE** Step response into dead-end system (1 cubic inch volume).

External Analog Input Impedance

4–20 mA: 250 Ω
1–5V: 220K Ω — single input pin to ground
1.7M Ω — differential input
0–10V: 100K Ω

Digital Inputs

Voltage Range/Input Impedance:

4–20 mA: 250 Ω
1–5V: 220K Ω — single input pin to ground
1.7M Ω — differential input
0–10V: 100K Ω

Digital Outputs

Current: 50 mA continuous, 100 mA instantaneous
Voltage: 5V to 28V
Type: Open collector, grounded emitter

Analog Output

4–20 mA: Better than 0.5% accuracy;
loads from 50 Ω to 1000 Ω
0–10V DC: Better than 0.5% accuracy;
loads no less than 5000 Ω



ER5000 Series — Features and Specifications

Hazardous Location Model (ER5050) Specifications

Certifications

Refer to *Hazardous Locations Special Requirements and Certification for the ER5050* for a complete list of hazardous location certifications.

Enclosure

Type 4X/IP66. If the two 1/2-14 NPTF ports are unused, properly seal with a metal plug.

CE Approved Wiring Instructions

Use shielded, twisted pair cable. Use rigid metal conduit to enclose the wiring entering the ER5050 when required per local electrical code.

Weight

2.6 lbs / 1.2 kg

Media

Supply pressure must be clean, dry inert gas or instrument grade air that meets the requirements of ISA Standard 7.0.01. Use of an in-line filter that meets the requirements of ISA standard 7.0.01 and is less than 40 microns and as small as 10 microns, is highly recommended to prevent damage to the solenoid valves. Moisture should be kept to a minimum.

Ports

Conduit: 1/2" NPTF
Pneumatic: 1/8" NPTF — Inlet, Exhaust and Gauge Ports
1/2" SAE — Controlled Outlet Port

Power Requirement

Voltage: 24V DC (22V DC to 28V DC)
Current: 340 mA max, 180 mA nominal

Environment

Temperature: -20°C to 60°C (dry Nitrogen supply gas)
5°C to 60°C (shop air)
Pressure: 28" to 32" Hg / 71 mm to 762 mm Hg
Humidity: To 100% R.H. (non-condensing) @ 0°C to 60°C.

Inlet Pressure

Minimum: Outlet pressure + 1 psig
Maximum: 110 psig / 7.5 bar
Typical: 110 psig / 7.5 bar

NOTE Response time is affected by input pressure.

Sensor Update Rate

25ms (rate of sensor reading and processing task)



ER5000 Series — Features and Specifications

Hazardous Location Model (ER5050) Specifications (cont.)

USB Communication Interface

USB:	2.0
Maximum cable length:	15 ft / 4.5 m
Connector:	Mini-B

NOTE Due to varying hazardous location wiring requirements, a USB cable is not included with the ER5050.

RS485 Communication Interface

Networking:	Up to 32 controllers on one network
Maximum cable length:	4000 ft / 1219 m
Baud rate:	9600

Flow Rate

C_v :	0.01
---------	------

NOTE The flow rate can be increased using a booster regulator.

Accuracy

Room temp:	0.1% of span maximum
------------	----------------------

Response Time

Rise Time:	257ms — 10 psig to 90 psig / 0.7 bar to 6.2 bar
Fall Time:	552ms — 90 psig to 10 psig / 6.2 bar to 0.7 bar

NOTE Step response into dead-end system (1 cubic inch volume).

External Analog Input Impedance

4–20 mA:	250 Ω
1–5V:	220K Ω — single input pin to ground 1.7M Ω — differential input
0–10V:	100K Ω

Digital Inputs

Voltage Range/Input Impedance:	
4–20 mA:	250 Ω
1–5V:	220K Ω — single input pin to ground 1.7M Ω — differential input
0–10V:	100K Ω

Digital Outputs

Current:	50 mA continuous, 100 mA instantaneous
Voltage:	5V to 28V
Type:	Open collector, grounded emitter

Analog Output

4–20 mA:	Better than 0.5% accuracy; loads from 50 Ω to 1000 Ω
0–10V DC:	Better than 0.5% accuracy; loads no less than 5000 Ω

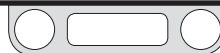

ER5000 Series — Features and Specifications

Accessories

Part #	Description
80129	1/8" NPTF male tube connector
82575-25	250 mA / 24V DC power supply — input voltage 120V AC, 60 Hz
82575-50	500 mA / 24V DC power supply — input voltage 120V AC, 60 Hz
82919	Potentiometer with digital display
82948	USB to RS485 converter
85061	RS232 to RS485 converter
85121	12-wire, shielded, twisted pair cable assembly — 24" / 61 cm Included with all standard ER5000s
ERSA04539	20-wire, shielded, twisted pair cable assembly — 24" / 61 cm Included with "F" model ER5000s
85138-X	12-wire, shielded, twisted pair cable assembly — 5, 10, 20, 50 and 100 ft / 1.5, 3, 6, 15 and 30 m options
ERSA04539-X	20-wire, shielded, twisted pair cable assembly — 5, 10 and 20 ft / 1.5, 3 and 6 m options
85145	Filter kit
ERAA03458-02	Adaptor fitting 1/2" SAE x 1/8" NPTF — mates ER5000 to most TESCOM™ air actuated regulators Included with all standard ER5000s
ERAA03458-04	1/2" SAE X 1/4" NPTF
ERAA03409	USB Cable with Mini-B connector Included with all standard ER5000s NOT for use with ER5050s
ERAA05146	MTA Connector Replacement Kit





WHAT'S NEW



ER5000 — What's New

New Features

- Built-in USB connectivity
- Improved resolution for data acquisition with 16-bit A/D converter
- For “F” model ER5000s, single 20-wire cable replaces separate 12-wire and 8-wire cables
- **Suspend Control**, a new operational mode available on “F” models, gives you the ability to lock output at a stable pressure over an extended period of time for operations, such as sensor calibration, where system stability is critical.
- **The ERTune™ program** has been upgraded to take full advantage of the Windows graphic user interface, with a single, unified operating environment and quick, tab-based access to all functions. Other enhancements include:
 - > Setup Wizard and COM Port Search speed up installation.
 - > The Tuning Tab now features highly responsive sliders, with optimal ranges for all configurable parameters clearly displayed in the interface.
 - > Data acquisition can now be triggered automatically by system events such as digital input detection or a monitored variable reaching a target value.
- > Profiles can now include up to 100 command segments. Loop counts are now displayed in real time.
- > For “F” model ER5000s, Profiles can now include these new commands:
 - Soak**, which waits until feedback indicates a new setpoint has been reached before initiating a Dwell.
 - If** and **Goto**, which allow you to create complex branching command sequences that respond to real-time operating conditions and inputs.
- > The Diagnostic Tools Tab now gives you one-click access to tuning and troubleshooting recommendations.
- > The Automated Solenoid Leak Test gives you a quick, intuitive and accurate assessment of the controller’s solenoid valves.
- > Regulator Diaphragm Protection is a new feature that gives an added layer of protection for applications where rapidly changing flow demands put undue stress on the sensing element of diaphragm sensed regulators, particularly those with metal diaphragms.



ER5000 — What's New

Replacing an ER3000 with an ER5000

IMPORTANT! Reference current Hazardous Location standards when replacing a Hazardous Location ER3000 with an ER5050.

WARNING

Safety standards are subject to continual revision. Investigate and apply the most recent standards for Hazardous Locations for your area set by ANSI, ISO and OSHA, as well as all electrical codes and fire and safety standards, before replacing a controller in a hazardous location.



Click this link to view all Hazardous Location certifications and specifications.

Wiring for the Standard Model ER5000

The wiring for the 12-pin MTA connector is the same for the ER5000SI-1 as it was for the ER3000SI-1. An MTA connector replacement kit is available to allow use of the existing installation cable with the new ER5000.

Wiring for the “F” Model ER5000

For “F” model ER5000s, the 12-pin MTA connector and 8-pin auxiliary MTA connector, which were previously fed by separate cables, are now fed by a single 20-wire cable. All wires feeding the 8-pin connector are color striped to distinguish them visually from the solid color wires feeding the 12-pin connector. Refer to Figure 18 to see all wire colors and pin terminations.

The function of the green/white wire (J4 Pin 5), which was previously the Analog Signal Ground, has changed: it now activates the Suspend Control function, which closes both valves and locks the controller at the current pressure. If your current application makes use of this wire, refer to the Installation Variations section for recommended wiring configurations.

For standard model ER5000s, there are two wires which act as signal/board grounds: the black wire (J3 Pin 10) and the tan wire (J3 Pin 12).

For “F” model ER5000s, the black/white wire (J4 Pin 6) also acts as signal/board ground.



ER5000 — What's New

Using the ER5000 with ER3000 software

If you wish to continue using the Windows Tune or other software that controlled your ER3000, you must install **Jumper J9** to put the ER5000 into ER3000 Mode (refer to Figure 19). The ER5000 uses a 16-bit A/D converter to translate analog input signals into the digital language the microprocessor understands, while the ER3000 uses a 12-bit converter. In order for the ER5000 to correctly interpret the signals generated by a program written for the ER3000, it must use a 12-bit scale.

NOTE Installing the ER3000 Mode Jumper will also turn off the new Suspend Control feature, as well as the new Profile commands.

UI3000 or UI4000

The ER5000 is **NOT** compatible with either the UI3000 or the UI4000.

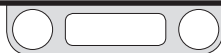



How It Works



ER5000 — How It Works

The ER5000: How It Works

The ER5000 (Electronic Regulator 5000) is a microprocessor-based PID (Proportional, Integral, Derivative) controller that brings precise algorithmic pressure control to a wide range of applications.

It can be used as a standalone unit to control the pressure of clean, dry inert gases from 0–100 psig / 0–6.9 bar or be connected to any pneumatically actuated regulator or valve. Used with TESCOM™ regulators, the ER5000 provides distributed pressure control of gases and liquids from vacuum to 30,000 psig / 2068 bar, with a C_v of up to 12.

The ER5000 can be controlled from any PC via a direct USB or RS485 connection. The ER5000 also accepts analog setpoint signals from 4–20 mA, 1–5V or 0–10V analog sources, such as from a PC or PLC D/A card. The ER5000 can be wired to allow for multiple input/output configurations and daisy chaining of up to 32 controllers within the same RS485 network.

The ER5000 senses pressure using either its internal sensor or an external transducer (4–20 mA, 1–5V or 0–10V) placed within the actual process line. You can operate the ER5000 in one of three control modes:

- Internal Feedback, which uses only the internal sensor;
- External Feedback, which uses only the external source;
- Cascade, which uses both internal and external sources in a “loop within a loop” configuration.

During setup, you can download PID settings that have been programmed by TESCOM to meet the needs of most commercial applications. The included ERTune™ program provides an intuitive interface to customize the performance parameters of the ER5000 by directly tuning the Proportional, Integral and Derivative values.

Using the ERTune™ program, you can create Profiles, which guide the ER5000 through command sequences that may include multiple setpoint changes, precisely timed digital inputs and outputs and modification of response characteristics and other internal variables based on real-time operational conditions.

The ER5000 installs in just minutes, yet provides the precision, dependability and flexibility to meet the needs of the most demanding user.



ER5000 — How It Works

Understanding PID Controllers

PID Controllers allow mechanical systems to operate at a high level of precision and dependability with only occasional oversight by human operators. They can control virtually any measurable physical property within the system, including pressure, flow, temperature, position, speed, force, consistency, torque and acceleration.

PID controllers operate in a continuous loop of monitoring and response. The ER5000 performs one loop every 25 ms (milliseconds).

At the start of each loop, the controller reads the input from a sensor within the system to find the current level of a measured property such as system pressure (the *Feedback*) and compares it to a preset target value (the *Setpoint*).

If the two values match, a *Zero Error* is generated and no action is taken. If the two values do not match, a positive or negative *Error* is generated and the controller activates to correct the error.

When the error is the result of an unintended change in the operating environment, the controller works to return the system to its previous level. When the error is the result of a scheduled

change in the setpoint, the controller works to raise or lower the system to the new target level.

In either case, the controller continues to act until setpoint and feedback are equal. The controller then generates a zero error and returns to its monitoring function. At this point, the system is said to be in a *Stable State*.

The response of the PID controller, from error generation to stable state, is shaped by a complex algorithm that incorporates three independent but interrelated values (also referred to as *Terms*).

- **The *Proportional (P) term*** is a function of the value of the error generated during the current loop. With each loop, the P value changes in direct proportion to the amount of error. Proportional is largest when the error is first detected and grows progressively smaller as the controller brings the system closer to setpoint.
- **The *Integral (I) term*** is a function of the combined values of all errors generated while the system is in operation. The I value continues to increase as long as the system is in error and will only decrease when an error is recorded in the opposite

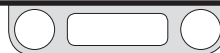

ER5000 — How It Works

direction. Significantly, Integral retains its value after the error has been corrected. This is known as *Integral Windup*.

- **The *Derivative (D) term*** is a function of the current rate of change. The D value decreases, then begins to dampen the other values, as the controller brings the system closer to setpoint.

PID Controllers: Three Components Are Better Than One

Why three independent values? Consider this scenario:

- You are behind the wheel of a car that needs to turn through a curve in the road.
- As the car enters the turn, you simply steer to match the curve. At this point, you are a Proportional controller.
- As the car continues through the turn, however, peripheral force pushes it outward. Matching the curve (Proportional only) is no longer sufficient. You now find it necessary to oversteer (add Integral) to stay in the curve. Then a gust of wind hits the side of the car; now you need to oversteer more to compensate for both the wind and the peripheral force (accumulated Integral).

- As the car passes the midpoint of the curve, the peripheral force decreases and the wind dies down. Now the oversteer (Proportional and accumulated Integral) threatens to put the car into a skid. You respond by understeering (adding Derivative) through the rest of the curve until you are back on straight road.
- As you drive on, you remember the wind that hit at the most inopportune moment, so you keep a close hand on the wheel in case there is another gust (Integral windup).

Like the driver who knows when to follow the road, when to oversteer and when to understeer, controllers that can combine the effects of Proportional, Integral and Derivative have the flexibility to respond effectively to the widest range of application requirements and environmental conditions.

Now consider the same curve with three different drivers.

- The first driver spots a police car in the next lane. This driver's primary goal will be to stay squarely within the lane through the whole length of the turn. This controller carefully balances Proportional, Integral and Derivative.



ER5000 — How It Works

- The second driver notices that there is a full cup of hot coffee in the cup holder. This driver will take the curve as widely and as slowly, as possible, because this driver's primary goal is to make sure the hot liquid does not spill. This controller has lowered the Proportional and Integral and increased the Derivative, to make the response as stable as possible, at the expense of some speed and precision.
- The third driver is participating in a road race. This driver will take the curve as tight and fast as possible, pushing the limits right up to the point of spinning the car out of control. This controller has maxed out the Proportional and Integral to get the fastest response possible, then set Derivative just enough to reestablish control at the end.

Three controllers, three different goals, three different responses to the same change. By raising and lowering the relative amounts of Proportional, Integral and Derivative (a process called Tuning the controller) you can set up your ER5000 to meet the specific response characteristics and work within the specific limitations, of any system.

A Typical PID Control System

Figure 2 shows a simplified diagram of a typical PID control system.

In this drawing, the dashed line represents the controller. The setpoint (r) is sent from the internal board or an external source. The feedback (y) is sent from internal or external sensors that monitor the current state of the system. The controller reads both values and subtracts the feedback signal from the setpoint.

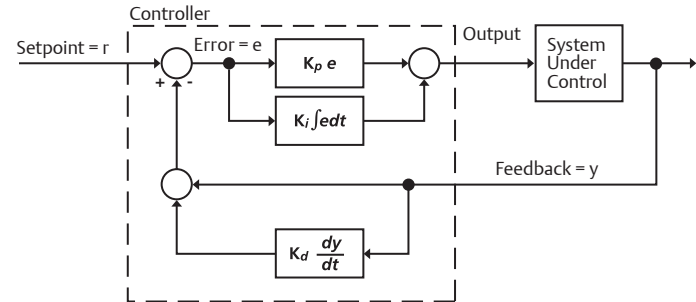
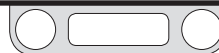

Figure 2: Simplified PID Control System



ER5000 — How It Works

If setpoint and feedback match, the controller generates a zero error and does not activate.

If setpoint and feedback do not match, the controller generates an error value (**e**), activates and sends an output to the system to correct the error. For example, in the ER5000 the output is directed to Solenoid Valves within the controller.

A positive error is generated when feedback is lower than setpoint. The ER5000 responds to positive error by activating to increase system pressure.

A negative error is generated when feedback is higher than setpoint. The ER5000 responds to negative error by activating to decrease system pressure.

The controller determines how much output to send by summing two values:

- The Proportional term, which is the product of the generated error and the constant **K_p** (the Proportional Constant).
- The Integral term, which is the product of the integral of all accumulated errors and the constant **K_i** (the Integral Constant).

Control systems based on just the Proportional term or just the Proportional and Integral terms, are known as a P and PI configurations. The ER5000 can operate in a P or PI configuration if this is appropriate for the application. The PID configuration, which includes the Derivative term, offers the greatest level of precision and flexibility.

The Derivative term is often used to attenuate the feedback before it is compared to setpoint. It is shown this way in Figure 2. The Derivative of the feedback is multiplied by the constant **K_d** (the Derivative Constant) and the resulting value is summed with the feedback.

Because the Derivative is a function of the rate of change, its primary function is to act as a damper and suppress oscillations as the system approaches setpoint.

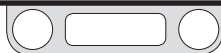

ER5000 — How It Works

Tuning a PID Controller

Tuning a controller is the process of selecting the optimal **K_p**, **K_i** and **K_d** settings to yield the best response. The “best” response depends on what is most important for the application and usually entails a compromise between speed of response and stability.

Your ER5000 is pre-tuned at the factory and a default PID setting configured by TESCOM™ to match your TESCOM regulator can be downloaded to the controller during setup. For many users, the default tuning will provide effective system control right out of the box. Others will find that the specific requirements of their application or operating environment call for some additional manual tuning, using the ERTune™ program, to achieve optimal performance.

The mathematics of PID algorithms are complex and beyond the scope of this manual. Understanding the response characteristics of your system will inevitably involve trial and error.

Nonetheless, PID tuning can also be understood in basic functional terms. There are predictable effects, both positive and negative, to watch for as settings are increased or decreased. If necessary,

default settings can be restored with the click of a button (see To reset the ER5000 to its default PID settings).

Using a few rules of thumb and the real-time visual feedback provided by the ERTune™ program, all operators, regardless of experience, can achieve positive results through manual tuning of their controllers.

Rules of Thumb for PID Tuning

- The Proportional setting controls the overall response curve of the controller. It is set first. Integral and Derivative are added to fine tune the response.
- The Integral setting accelerates the response, particularly as the system approaches setpoint and the Proportional decreases. It is primarily used to minimize a condition known as **Steady State Error** or **Offset**, where the system settles into a stable state without reaching the targeted setpoint. The Integral also remains “charged up” with Integral windup after an error has been corrected.
- The Derivative setting dampens the response and is used to prevent the system from overcorrecting. Generally set next after Proportional.

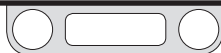

ER5000 — How It Works

Figure 3 shows four typical response curves to a step (instantaneous) change in setpoint.

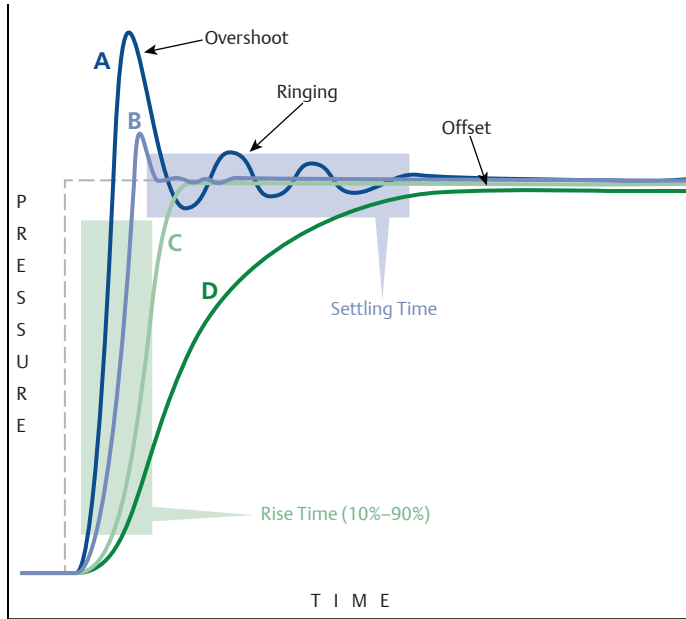

Figure 3: Typical Response Curves to Programmed Setpoint Change

The controller in Curve A responds with a Rise Time that is short and sharp. It also overcorrects (Overshoots) the error and oscillates around the new setpoint, a condition known as Ringing. There is a prolonged Settling Time before the system reaches its new stable state. The overall response is quick but unstable.

The controller in Curve D has a long, gradual rise time and ends up in Steady State Error, settling into a stable state that is slightly below the new setpoint.

Curve A demonstrates the unwanted effects of a fast, but also unstable, response. Tuning this controller will entail lowering the Proportional setting and perhaps the Integral setting as well. Alternatively, increasing the Derivative will help to stabilize the response. Curve D demonstrates the unwanted effects of a stable, but overly slow, response. Tuning this controller will entail increasing Proportional. Integral also should be increased to eliminate the offset. Derivative should be checked to see if it is overdamping the response.

The controllers in Curves B and C have been tuned to achieve a balance between speed and stability. Curve B allows a small amount of overshoot and ringing in exchange for the fastest rise time possible, with a settling time that is short and stable. Curve C is

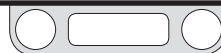

ER5000 — How It Works

“critically damped,” with just enough Derivative added to eliminate overshoot completely. Both tunings have no offset. Curve B would be an optimal tuning for an application which can tolerate overshoot, Curve C for one which cannot.

To restate the rules of thumb for each component:

Proportional (P):

- Higher settings result in shorter rise times and faster response.
- Higher settings also make the response less stable, with overshoot and ringing. Overshoot may tax the physical limitations of the system.
- Lower settings result in slower response.

Integral (I):

- Higher settings accelerate the response.
- Higher settings also increase instability.
- Lower settings result in a less responsive controller.
- Because Integral windup continues to push the response even after the system has reached stable state, higher Integral settings can eliminate offset.

- Windup can delay the controller’s response to new errors, as accumulated errors must “spool out” before new errors can begin “charging up” Integral. The ER5000 features exclusive *Integral Limits* to control positive and negative windup, allowing you to use higher Integral settings.
- The Integral of small errors can, over time, accumulate to the point of causing unwanted activation of the controller. The ER5000 features an exclusive filter called *Integral Deadband* to mitigate this effect.

Derivative (D):

- Higher settings correct overshoot and ringing.
- Higher settings also decrease settling time and increase system stability.
- Higher settings may overdamp the system, causing a slow rise time.
- Paradoxically, higher Derivative settings can make some systems unstable by increasing sensitivity to transient changes (noise) in the operating environment. This sensitivity can decrease the operational lifespan of the ER5000’s solenoid valves due to frequent activation.

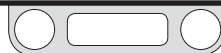

ER5000 — How It Works

Table 1 gives a summary of the rules of thumb for Proportional, Integral and Derivative.

Table 1: Effect of P, I and D Increases on Response Curve of Controller

	Increased P Value	Increased I Value	Increased D Value
Rise Time	Faster	Faster	Slower
Instability (Overshoot/Ringing)	More	More	Less*
Settling Time	Varies	Longer	Shorter
Offset	Less	Eliminate	Varies

* Excess D Value can, however, result in more instability rather than less. Refer to the restatement of the rules of thumb for Derivative on page 37.

The ERTune™ program gives you a rich visual environment and precise, intuitive controls for tuning the ER5000. Refer to The Tuning Tab: Controls and Functions for Tuning the ER5000 for a detailed explanation of the program's capabilities and features, as well as tips and techniques to achieve optimal system performance.

Every system has unique characteristics, every operational environment presents unique challenges and every application has unique requirements. Optimal tuning will invariably involve both trial and error and compromise. Fast rise time usually comes at the expense of increased instability. Minimizing overshoot may result in response lag or offset. Eliminating offset may introduce unwanted windup. It is important to know your priorities and understand the trade-offs.

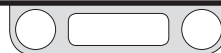

ER5000 — Typical Application

The ER5000: Typical Application *(Non-Hazardous Location)*

⚠ WARNING

Investigate and apply the most recent standards for Hazardous Locations for your area set by ANSI, ISO and OSHA, as well as all electrical codes and fire and safety standards, to determine if your application will require a Hazardous Location model. If your application requires a Hazardous Location model (ER5050), refer to *Installing a Hazardous Location Model (ER5050)* on page 110.

Controlling System Pressure

In a typical application, the Outlet Port of the ER5000 connects to the top of a Dome Loaded or Air Actuated pressure reducing Regulator, usually through the included 1/2" SAE x 1/8" NPTF adaptor. This is shown in Figure 4.

Supply Pressure of up to 120 psig / 8.2 bar, with 110 psig / 7.5 bar being typical, is provided to the ER5000 by an external source. The ER5000 increases Pilot Pressure to the air actuator of the regulator by opening the Pulse Width Modulation (PWM) solenoid valve at the Inlet Port and reduces pilot pressure by opening the PWM solenoid valve at the Exhaust Port. Normally, the exhaust vents to atmosphere.

The controller, configured in External Feedback mode, senses System Pressure through input from a transducer mounted downstream in the Process Line.

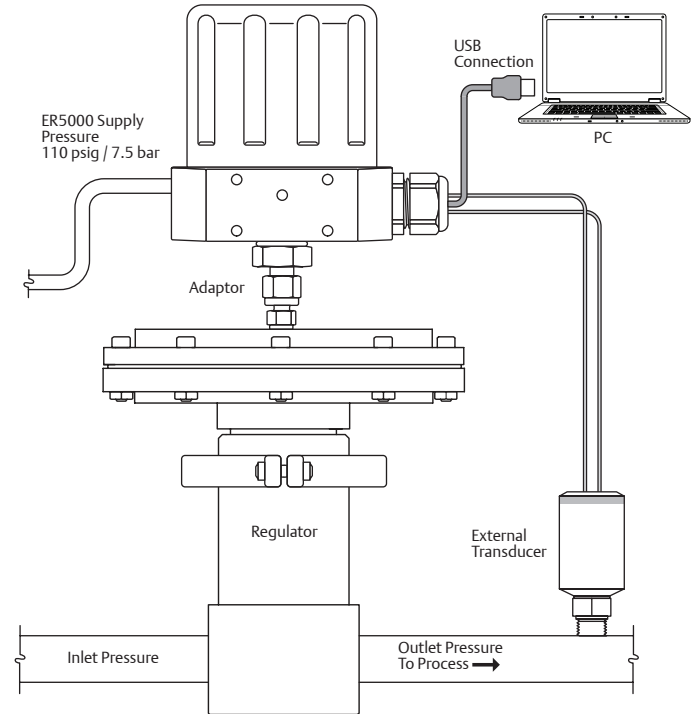

Figure 4: Typical ER5000 Application

Controller, with adaptor, is mounted to an air actuated regulator. Feedback is from the external transducer. Setpoint is from a Profile downloaded from the PC through the USB connection.



ER5000 — Typical Application

Every 25 milliseconds, the controller reads the feedback and compares it to the setpoint, which it receives from an external source or from a Profile in its onboard memory. If feedback is lower than setpoint, the ER5000 activates the inlet valve, allowing Pilot Pressure to flow into the actuator of the regulator. This causes the main valve of the regulator to open up, resulting in an increase in downstream System Pressure. The ER5000 will continue to send pilot pressure into the air actuator of the regulator until feedback and setpoint are equal. At that point, the inlet valve closes, stabilizing the system at that pressure.

If feedback is higher than setpoint, the ER5000 activates the exhaust valve, releasing pilot pressure from the regulator. The decrease in pilot pressure causes the main valve of the regulator to close up and also causes the regulator vent to open, exhausting excess system pressure (if your application uses a non-venting regulator, refer to page 41). The result is a decrease in downstream system pressure. The ER5000 will continue to exhaust pilot pressure until the feedback signal is equal to the setpoint. At that point, the exhaust valve closes, stabilizing the system at that pressure.

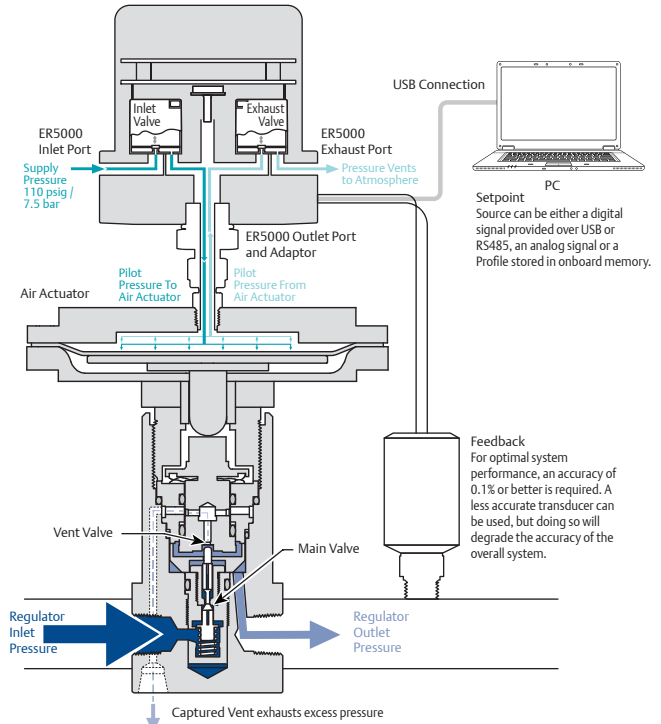

Figure 5: Internal Operation of the ER5000 Controller



ER5000 — Typical Application

A Note Concerning Non-Venting Regulators in Closed Loop Applications

Non-venting regulators, which do not feature a regulator vent to exhaust excess system pressure, pose a particular challenge in closed loop applications when the downstream flow is blocked.

When downstream flow stops suddenly, for example when a downstream valve is closed, feedback rises rapidly. The regulator responds by closing its main valve. However, due to **Lock-up** in the regulator, a small amount of excess pressure escapes through the main valve before it achieves a completely tight seal.

In venting regulators, this excess downstream pressure is exhausted by the regulator vent, allowing the system to return to stable state. In non-venting regulators, this excess pressure is trapped in the downstream pipe.

The PID controller senses the rise in feedback and activates to lower system pressure. But the regulator cannot respond, since it cannot vent. Because the excess system pressure is trapped, the error will not change. The controller could continue to respond until the pilot pressure is completely vented through the exhaust valve. This can create two different undesirable conditions:

- If the regulator is a metal diaphragm sensed regulator, the differential between the high downstream pressure beneath the diaphragm and the low (or even zero) pilot pressure above the diaphragm can critically stress the diaphragm.
- Regardless of regulator type, if the downstream flow suddenly restarts, the PID controller's response will be delayed, because it will need to completely refill the regulator's dome or air actuator cavity.

When the **Diaphragm Protection** feature of the ER5000 is activated, the controller responds to error only up to a set percentage of the original pilot pressure, then stops. This allows the controller and regulator to be reset quickly once system flow has been restored and minimizes pressure differentials that can effect regulator components.

The **Regulator Diaphragm Protection** feature is strongly recommended for applications using metal diaphragm sensed regulators. It provides a control benefit for applications using non-venting regulators. It is not required for applications using venting regulators or piston sensed regulators.

Refer to **The Diaphragm Protection Panel** to learn more about this feature.

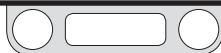

ER5000 — Typical Application

Monitoring System Control Limits

The ER5000 also can be configured to monitor the system and respond if user-specified limits are exceeded. This function is deactivated by default and can be activated using controls in the ERTune™ program. Refer to The Control Limits Panel section for more information.

This feature provides added security in the event of a system failure such as broken transducer wiring, lack of supply pressure or pipe ruptures.

CAUTION

The Control Limits feature provides an additional level of system monitoring. Activation indicates a potential problem, but will not, by itself, prevent problems from occurring. It should not be considered to be a safety mechanism, nor is it intended to be a safety feature or pressure limiting device.

When an ER5000 configured to monitor Control Limits detects a signal indicating that a limit has been exceeded, it activates its solenoid valves to reach one of three Control Limit Conditions:

- Inlet Closed/Exhaust Closed
- Inlet Closed/Exhaust Open
- Inlet Open/Exhaust Closed.

The default Condition is Inlet Closed/Exhaust Open, which ensures that a pressure reducing system will be vented if a limit is exceeded. If your application uses a non-venting regulator, refer to A Note Concerning Non-Venting Regulators in Closed Loop Applications if you intend to use the ER5000 in this condition.

Minimum and maximum limits can be monitored for any or all of these variables:

- Analog Setpoint
- Internal Sensor
- External Sensor
- Inner Error
- Outer Error.



ER5000 — Control Modes

The ER5000: Control Modes

Internal Feedback Mode

Internal Feedback Mode uses the ER5000's internal sensor to monitor the pressure within the controller's 0–100 psig / 0–6.9 bar internal pressure range. This mode is typically used when the ER5000 is used as a standalone unit or when open-loop control of a regulator is desired.

External Feedback Mode

External Feedback Mode uses a user-supplied external transducer to monitor the system pressure. The transducer is installed in the process line and provides direct feedback to the ER5000. This mode is typically used when the ER5000 acts as the pilot regulator for a regulator or valve.

An external transducer may also be installed in the ER5000's pressure line when the ER5000 is used as a standalone unit. This may be preferable to Internal Feedback mode when:

- The application requires precise control within a small pressure range. For example, the ER5000 will respond more efficiently to a 5% change in a 0–10 psig / 0–0.7 bar range than to a 0.5% change in its full 0–100 psig / 0–6.9 bar range.

- There is a need to monitor downstream pressure. For example, if the output passes through a length of pipe to a vessel and it is expected that there will be pressure drops in the pipe, an external sensor installed at the vessel will provide a more responsive feedback signal than the controller's internal sensor.

Cascade Mode

Cascade Mode implements one PID loop within another PID loop. The inner loop uses the controller's internal sensor and the outer loop uses an external sensor. This mode of operation creates more stability, but slows down the response of the system.

NOTE For proper operation in Cascade Mode, the following recommended defaults for the *Integral Limits* of the external feedback loop (also known as the outer loop) are downloaded into the controller during setup: Maximum: 32767; Minimum: 0. These settings are optimal for most applications.

Refer to [The Cascade Tuning Tips](#) and [The Integral Limits Controllers](#) for more information on these settings.





GLOSSARY OF TERMS



ER5000 — Glossary of Terms

Terms Relating to PID Controllers and Controller Tuning

D/A Cards

Acronym for Digital To Analog Card. Used in PCs and PLCs to generate analog signals.

Daisychain

Multiple ER5000s wired together in sequence that communicate with a single, central PC on the same RS485 network. Each controller within the chain must be given a unique *Node Address*, which is done using the ERTune™ program.

Deadband

See *Integral Deadband* and *Pulse Deadband*.

Derivative

The component of a controller's response that is based on the rate of change within the system. Generally acts to dampen the effect of *Proportional* and *Integral* and to increase system stability.

Error

The result that is generated when *Feedback* is subtracted from *Setpoint*. A zero error results in no activation. A non-zero error

causes the ER5000 to activate until the error is corrected. A positive error causes the ER5000 to increase system pressure and a negative error causes the ER5000 to decrease system pressure.

Feedback

The input sent from an internal or external sensor that indicates the current level of the process a PID controller manages. The controller subtracts feedback from *Setpoint*, generating an *Error* and any non-zero error activates the controller.

Hazardous Location

The Hazardous locations are areas where flammable liquids, gases or vapors or combustible dusts exist in sufficient quantities to produce an explosion or fire. Specially designed equipment and special installation techniques must be used in these applications, because an electric current is present during normal operation of the controller, so there is the potential to generate a spark. If your application environment meets the standard for a Hazardous Location, you MUST use model ER5050 and follow the installation specifications outlined on [page 110](#) in order to provide a safe operating environment.

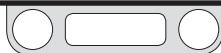

ER5000 — Glossary of Terms

Integral

The component of a controller's response that is based on accumulated error within the system. Continues to accumulate as long as there is a non-zero Error and retains its value until errors are generated in the opposite direction. Accelerates the effect of Proportional. Often referred to as "reset," because its continually increasing value effectively "resets" the value of Setpoint within the controller's computations above or below its actual level. This allows PID controllers to eliminate Offset. The retained Integral value, also known as Integral Windup, must be carefully controlled to prevent response lag.

Integral Deadband

Stop-band filter that deactivates Integral within a set percentage range around Setpoint. Prevents small, transient errors from accumulating to a level that activates the controller. Accessed through The Tuning Tab in the ERTune™ program.

Integral Windup

Amount of accumulated value that is retained by Integral after error has been corrected. Excess windup can cause the controller to lag in response to new Errors. Proper Tuning prevents windup by setting limits on accumulated value through the Integral Limits.

Integral Limits

Pair of filters which limit the amount of Integral Windup that can accumulate during Error correction. **Maximum** limit is set for positive errors (Setpoint minus Feedback is positive). **Minimum** limit is set for negative errors (setpoint minus feedback is negative). Accessed through The Tuning Tab in the ERTune™ program. Allow for high Integral settings without unwanted effects. Generally set to the smallest value necessary to eliminate Offset.

Node Address

Virtual address of the ER5000 within a network. Each controller is assigned a default address of 250 at the factory. When multiple ER5000s are in a Daisychain within the same RS485 network, each controller must be assigned a unique address so that the PC can locate and communicate independently with each controller. The Node Address can be changed using The Configure Tab in the ERTune™ program.

Noise

Short, transient changes to the system that are generally too small to require activation of the PID Controller. A Derivative setting that is too high may make the controller overly reactive

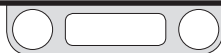

ER5000 — Glossary of Terms

to noise, at the expense of system stability and cycle life of the ER5000's solenoid valves.

Offset

Also known as Steady State Error: a condition of Proportional-only response where the system reaches a stable state that is slightly above or below the targeted Setpoint. Two aspects of Proportional contribute to this effect: the inevitable mechanical lag between generation of Error and the physical response of the valves to the controller output and the fact that a response that is a direct multiple of error will always fall short of 100% error correction. Proper Tuning generally aims to eliminate offset by adding Integral.

Open Collector

A common type of output for integrated circuits, where the emitter of the transistor is connected to ground and the collector of the transistor is connected to the output. Instead of outputting a signal of a specific voltage or current, the output acts as either an open circuit or a connection to ground. Open collector circuits are used in many systems, such as to interface devices that have different operating voltage levels or to connect multiple open collector devices to a single line.

Overshoot

Overcorrection due to a Proportional or Integral setting that is too high. Must be carefully controlled to keep response within the operational parameters of the system. Proper Tuning generally aims to minimize overshoot.

PC

Acronym for Personal Computer.

PID Controller

An automated control device that monitors a property of a mechanical system in a continual loop and uses an algorithm incorporating a Proportional, Integral and Derivative component to correct Error and maintain system stability.

Pilot Pressure

The pressure applied to the top of a Dome Loaded or Air Actuated Regulator that controls the Control Pressure of that regulator. The ER5000 is most commonly used to control pilot pressure to a dome loaded or air actuated regulator.

PLC

Acronym for Programmable Logic Controller.



ER5000 — Glossary of Terms

Pressure Reducing Regulator

Regulator that reduces high-pressure supplies of gas or liquid to a safe or usable level for an application.

Process Line

Area within a system where the activity takes place that is controlled by the PID controller, such as the pressure within a pipeline or vessel. External sensors send **Feedback** from the process line to the controller.

Profile

Command sequence, created using **The Profile Builder Panel** in the **ERTune™** program, which can be downloaded to the control board of the ER5000. Guides the ER5000 through a set of actions that may include multiple **Setpoint** changes, modification of response characteristics and other internal **Variables** based on real-time operational conditions and, in “F” model controllers, precisely timed digital inputs and outputs. Profiles may also be saved to a PC for future use.

Proportional

The component of a controller’s response that is a direct function of the **Error** generated by the current level of **Feedback** from the system.

Pulse Deadband

Stop-band filter that deactivates **Pulse Mode** within a set percentage range around **Setpoint**.

Pulse Mode

Refer to **The Pulse Mode Panel** for a complete description of this feature.

Pulse Width Modulation (PWM)

Method of controlling a device such as a mechanical valve using the control signal from a digital microprocessor (which can only be ON or OFF) by varying the amount of time during a given cycle when the ON signal is being sent.

The proportion of time that the signal is ON, from 0% to 100% of the cycle, is known as the “duty cycle”. Because of mechanical lag (the amount of time it takes for the valve to physically respond to the instantaneous change in signal), the valve is constantly “catching up” with the ON/OFF control signal in direct proportion to the duty cycle. For example, a duty cycle of 75% results in a valve that is approximately three-quarters open during that cycle.

The inlet and exhaust valves in the ER5000 are both PWM driven, with a cycle time of 25 milliseconds.



ER5000 — Glossary of Terms

Regulator

Mechanical valve that dynamically controls the pressure of liquid or gas in a process line by opening or closing in response to activation of an internal control element. Works to ensure that the supplied pressure matches the demand of the system.

Ringling

Oscillation around a Setpoint, due to a Proportional or Integral setting that is too high or a Derivative setting that is too low. Proper Tuning generally aims to minimize ringling.

Rise Time

Time required for feedback to reach a new Setpoint or a certain percentage of that setpoint, following a Step Change. TESCOM™ uses the ISA standard, which specifies rise time as the time it takes to travel from 10% to 90% of the new setpoint. Proper Tuning aims to minimize rise time without inducing Overshoot or Ringling.

Segment

One command line within a Profile.

Setpoint

The value that a PID Controller works to maintain within the system it controls. The setpoint may remain at one level or change over time, depending on the requirements of the system. A well tuned controller will maintain a Stable State at setpoint and implement setpoint changes quickly and accurately. The ER5000 requires a setpoint signal in order to function. This signal can come from an external source such as a PC or PLC or from a Profile.

Settling Time

Time required for a system to reach a stable state once it has reached a new setpoint. Proper Tuning generally aims to minimize Settling Time.

Solenoid Valve

An electromechanical valve controlled by electrical current through a coil. The ER5000 valves are Pulse Width Modulation (PWM) driven mechanical valves that open and close in direct proportion to the output signal from the controller's microprocessor. Positive output activates the inlet valve, increasing pressure and negative output activates the exhaust valve, decreasing pressure.



ER5000 — Glossary of Terms

Stable State

Any time that a PID Controller generates a zero Error for more than one loop of monitoring and response. Proper Tuning aims to find a correct balance between stability and speed of response.

Steady State Error

See Offset.

Step Change

Change in Setpoint that occurs within a single loop of monitoring and response for a PID controller.

Supply Pressure

Pressure applied to the inlet of the ER5000 from an external source. Sent by the ER5000 as Pilot Pressure to pilot a Dome Loaded or Air Actuated Regulator.

System Pressure

The pressure of the gas or liquid in a Process Line that is controlled by the Regulator, which is controlled in turn by the Pilot Pressure from the PID Controller. There are two components to system pressure: the inlet pressure (upstream pressure), which is the pressure level of the gas or liquid in the process line at the point where it enters the regulator and the outlet pressure (downstream pressure), which is the pressure level of the gas or liquid as it exits the regulator. For a Pressure Reducing Regulator, the inlet pressure must be higher than the outlet pressure.

Term

Used alternatively with value when referring to Proportional, Integral and Derivative.

Transducer

Commonly used term for an external sensing device that provides a feedback signal.



ER5000 — Glossary of Terms

Tuning

The process of setting values for the Proportional, Integral and Derivative constants within the PID Controller to achieve optimal performance.

Variable

Any configuration setting for the ER5000, such as the Proportional, Integral and Derivative constants, the setpoint value, the Control Mode or the Node Address. Refer to the Internal Variables section for a complete list. Variable values can be included in data collection and certain variables can be tracked using The Plot Screen of the ERTune™ program.



ER5000 — Glossary of Terms

Terms Relating to Regulators

Accuracy

The acceptable level of pressure variation for a Regulator under steady state conditions within its control range. All physical and mechanical processes have some level of variation.

Air Actuated

Also known as Air Loaded: one type of loading element for a pressure Regulator. Utilizes low pressure gas as the Loading Element (Loading Force), typically 0–80 psig / 0–5.5 bar. This is a form of ratio loading: the regulator uses low Pilot Pressure to regulate a Control Pressure that may be much higher (see Ratio Actuator). The most common type of regulator used with the ER5000, as it is the only type that can be used for control pressures greater than 100 psig / 6.9 bar.

Captured Venting

Feature incorporated in some venting Regulators which provides an additional port that can be connected to piping in order to safely

dispose of excess liquid or gas expelled by the regulator's vent valve. The vent port should never be plugged. Not all venting regulators have this feature. Refer to Venting Regulator.

Control Element

One of the three basic elements of a Regulator. Acts to reduce high Inlet Pressure to a lower working pressure (Outlet Pressure). The control element is sometimes called the main valve, valve stem or poppet.

Control Pressure

The component of System Pressure that is the result of the regulating action of the Regulator. Can be either the Outlet Pressure or the Inlet Pressure, depending on the type of regulator. For a pressure reducing regulator, the control pressure is the Outlet pressure. For a back pressure regulator, the control pressure is the Inlet pressure.

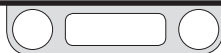

ER5000 — Glossary of Terms

Creep

An increase in the **Outlet Pressure** following **Lock-up**. Usually seen as a slow, gradual pressure increase. Indicates a regulator leak and calls for the immediate removal of the regulator for service.

C_v

The flow coefficient: equal to the number of U.S. Gallons of water at 60°F / 16°C that will flow through a valve, regulator or restriction in one minute when the pressure differential between inlet and outlet is one pound per square inch (1 psi). When gas is used instead of liquid, the equation is modified to account for the use of a compressible fluid. For a regulator, C_v is determined when the regulator is wide open and not regulating. When determining actual performance during regulating conditions, use flow curves.

Decaying Inlet Characteristic

Also known as **Supply Pressure Effect**. The effect on the set pressure of a regulator as a result of an **Inlet Pressure** change; usually an increase in **Outlet Pressure** due to a decrease in inlet pressure.

In pressure reducing regulators, outlet pressure is set when force from the load element, which opens the main valve, is matched

by inlet pressure moving through the valve. If inlet pressure decreases, for example when a supply cylinder starts to empty and the inlet pressure it supplies starts to decrease, this tips the balance in favor of the load element and opens the valve wider. This allows more flow, which results in a higher output pressure and the seemingly paradoxical fact that a decrease in inlet pressure results in an increase in outlet pressure.

Two-stage regulator design or the use of PID controllers, can prevent this characteristic.

Diaphragm

One of several types of **Sensing Element**. A diaphragm is sensitive in reacting to pressure changes. Common diaphragm materials are Buna-N, Viton, Ethylene Propylene, 316 Stainless Steel and Elgiloy.

Dome Loaded

One type of **Loading Element**. **Pilot Pressure** enters the dome at a pressure equal to the **Outlet Pressure** desired. Generally requires some additional pressure to activate: refer to **Negative Bias**. Can be used with the ER5000 for low **Control Pressure** applications.



ER5000 — Glossary of Terms

Drop

The Outlet Pressure change (offset) which occurs as flow rate increases and which causes outlet pressure to stabilize at a rate that is slightly offset from the expected Set Pressure under flowing conditions. Caused by variations in the response characteristics of the mechanical components of regulators at different flow rates. PID Controllers are often used to eliminate droop.

Flow Capacity (C_v)

Refer to C_v .

Flow Rate (Q)

The quantity of fluid being passed through a Regulator or valve during a specified time period. Units of measure include Standard Cubic Feet per Minute (SCFM), Pounds per minute (lbs/min), Liters per Minute (L/Mn), Gallons Per Minute (GPM), Grams per Second (g/sec) and Kilograms per Hour (Kg/hr).

Loading Element (Loading Force)

One of the three basic elements of a Regulator. The external force, such as the Pilot Pressure from a PID Controller or the downward pressure of a knob-activated spring, that acts on the

Sensing Element and causes the Control Element to respond by opening or closing the main valve. The three common types of loading elements are Spring Loaded, Dome Loaded and Air Actuated. The ER5000 can be used with either dome loaded or air actuated regulators.

Lock-up

The Outlet Pressure rise above setpoint pressure as the flow is decreased to zero.

Regulators respond to a sudden increase in downstream pressure by closing the main valve. There is, however, a slight lag in achieving a completely tight seal of the valve. This can be caused by the mechanical response time of the valve or because some extra pressure is required to force the seat into the sealing surface enough to make the seal 100% tight. Good regulator design aims to minimize lock-up.

In most applications, a PID Controller will automatically correct the small pressure rise that is due to lock-up.



ER5000 — Glossary of Terms

Pilot Regulator

Device that controls pressure to the actuation port of a dome loaded or air actuated Regulator. In its simplest form, the ER5000 is a pilot regulator.

Negative Bias

For Dome Loaded Regulators, the amount of Loading Force beyond the desired setpoint that is necessary to overcome the physical resistance of the Sensing Element (such as a diaphragm or piston o-ring) and initiate a dynamic response from the regulator. For example, to initiate a 1 psig / 0.07 bar setpoint, it may initially require 26 psig / 1.8 bar of Pilot Pressure to open the regulator valve and allow flow. Once dynamic response has been initiated, the dome loaded regulator tracks at a 1:1 relationship between pilot pressure and Control Pressure, so an additional 25 psig / 1.7 bar of pilot pressure will result in a jump from 1 psig to 26 psig / 0.07 bar to 1.8 bar in control pressure.

Please discuss with your TESCOTM representative if you are using a dome loaded regulator with the ER5000, as the amount of negative bias varies among different dome loaded regulator models.

Piston

One type of Sensing Element. Used for high pressure applications, up to 30,000 psig / 2068 bar.

psia (absolute pressure)

A measure of pressure in pounds per square inch (psi) that is referenced to zero absolute pressure.

psig (gauge pressure)

A measure of pressure in pounds per square inch (psi) that is referenced to atmospheric pressure.

Ratio Actuator

Device that amplifies the force generated by the Loading Element (Loading Force) in air actuated Regulators. Allows a relatively small Pilot Pressure to regulate a Control Pressure that is many times greater. TESCO air actuated regulators are available with ratios from 2:1 to 375:1.

Repeatability

The ability of a Regulator to return to the same Set Pressure after being subjected to various flow demands.



ER5000 — Glossary of Terms

Sensing Element

One of three basic elements of a pressure Regulator. Senses the changes in the control pressure (or process line) which allows the regulator to react and attempt to return to the original set pressure. Diaphragm and Piston are the two most commonly used sensing elements.

Set Pressure

The desired operational control pressure for a Regulator, normally stated at FIRST FLOW conditions.

Venting Regulator

A pressure reducing Regulator that can vent the Outlet Pressure (downstream pressure) when the loading/actuation force is decreased. A decrease in Pilot Pressure causes the regulator to vent.





GETTING STARTED



ER5000 — Getting Started

Before You Begin

WARNING



Investigate and apply the most recent standards for Hazardous Locations for your area set by ANSI, ISO and OSHA, as well as all electrical codes and fire and safety standards, to determine if your application will require a Hazardous Location model.

WARNING

Avoid personal injury or property damage from sudden release of pressure or bursting parts. Before proceeding with any installation procedures:



- Always wear protective clothing, gloves and eyewear to prevent personal injury or property damage.
- Do not remove the ER5000 or any other component of the system while the system is pressurized.



- Disconnect any operating lines providing air pressure, electric power or a control signal to the ER5000 prior to installation or maintenance.
- Use bypass valves or completely shut off the process to isolate the ER5000 and associated equipment from process pressure prior to installation or maintenance. Relieve process pressure on both sides of the controller and associated equipment.



- Use lock-out procedures to be sure that the above measures stay in effect while you work on the equipment.
- Check with your process or safety engineer for any additional measures that must be taken to protect against process media dangers.



Do not install, operate or maintain an ER5000 controller or any associated equipment, without reading and fully understanding the installation guidelines and operating instructions for every component of your application. To avoid personal injury or property damage, it is important to carefully read, understand and follow all contents of this manual, including all safety cautions and warnings in the Safety, Installation & Operations Precautions section. If you have any questions about these instructions, contact your TESCOTM sales office before proceeding.

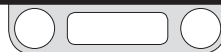

ER5000 — Getting Started

ER5000 Quick Reference: Jumpers, Terminal Blocks and Wires and LEDs

Jumpers: 4–20 mA / 1–5V Models

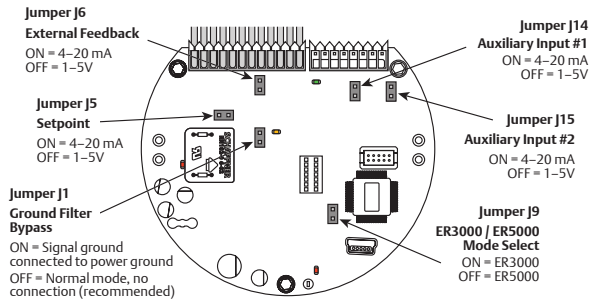

Jumpers: 0–10V Models

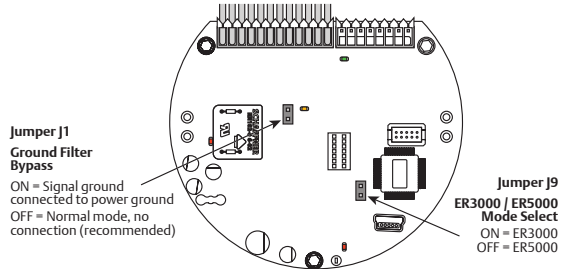

Terminal Blocks and Wires

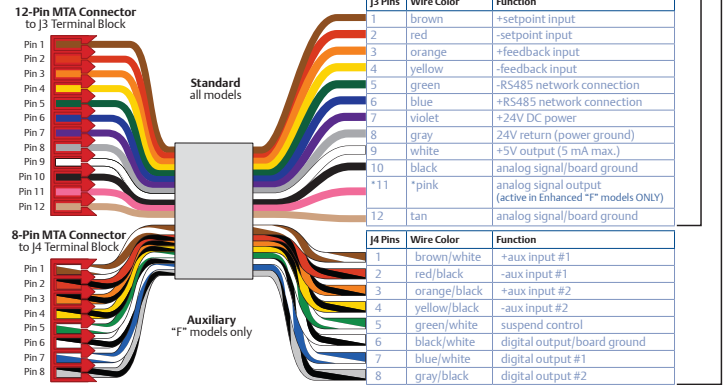

LEDs

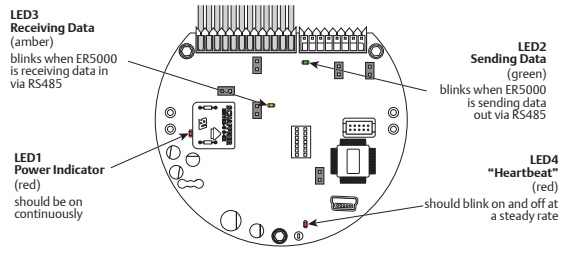

ER5000 — Getting Started

1

Verify your shipment

⚠ CAUTION



If you are replacing an ER3000 in an existing application, **be sure that you have read** Replacing an ER3000 with an ER5000 before you begin.

⚠ WARNING



If you are replacing a Hazardous Location ER3000 in an existing application, **be sure that you have read** *Installing a Hazardous Location Model (ER5050)* on page 110 before you begin.

Verify that all of these items are in the box you receive.

1. ER5000 or ER5050 Hazardous Location Electronic Pressure Controller
2. 3mm hex wrench for cover lock screw (ER5050 model only)
3. 1/2" SAE x 1/8" NPTF adaptor
4. Wiring connectors, pre-installed with strain relief
 - a. 12-pin MTA connector with 12-wire 18" / 45.7 cm cable (standard ER5000 models)
 - b. 12-pin and 8-pin MTA connectors with single 20-wire 18" / 45.7 cm cable ("F" model ER5000s)
5. USB cable with integrated strain relief (ER5000 models only)

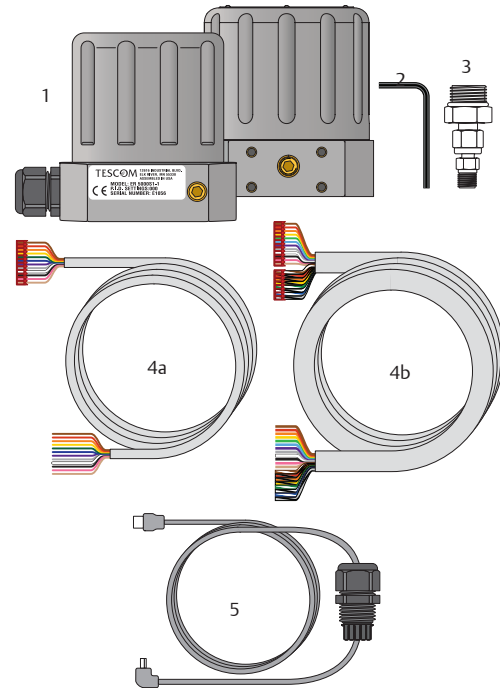
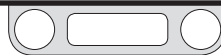

Figure 6: What's In The Box



ER5000 — Getting Started

Verify your shipment (cont.)

Additional items not included:

- 24V DC power supply*
- Setpoint signal source such as an analog output device*, PC or PLC
- Dome loaded or air actuated pressure regulator*
- Transducer for external feedback*
- 1/8" NPTF fitting for ER5000 Inlet Port
- Instrument grade air or Nitrogen supply —
 - > ER5000: 120 psig / 8.2 bar maximum
 - > ER5050: 110 psig / 7.5 bar maximum
- Computer for setup and tuning
- Wiring connectors such as a terminal strip or wiring nuts

 **NOTE** Items with an asterisk (*) are available from TESCOM™.

Tools you will need for the installation:

- Adjustable wrench
- Teflon tape
- Wire strippers

Additional items and tool you will need for an installation in a Hazardous Location:

- Conduit and connectors rated for your Hazardous Location

 **IMPORTANT!** ERTune™ software is compatible with the following operating systems: Windows XP, Windows Vista, Windows 7 and Windows 8.

 **IMPORTANT! Windows 8 users:** In order to maintain compatibility with previous Windows operating systems, the ERTune™ program uses the .NET Framework 3.5, which is not installed by default in Windows 8. If you are using Windows 8, you will need to download and install .NET Framework 3.5 before installing the ERTune™ program. You may also need to disable Driver Signature Enforcement to install the ER5000 driver. We have provided step-by-step instructions for both these tasks in Appendix A: Setting up the ERTune™ Program on Windows 8 PCs.

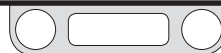

ER5000 — Getting Started

2

Verify the configuration of your application

⚠ WARNING

Improper selection of controllers, regulators, valves or accessories can cause death, serious injury and/or property damage.

⚠ WARNING

Installation in a hazardous location requires additional steps not described in this section. Refer to *Installing a Hazardous Location Model (ER5050)* on page 110 for more information.

This section assumes you will be installing the ER5000 in a typical configuration, which is shown in Figure 7 and includes the following components and connections:

- ER5000SI-1
- Controller is mounted on top of an air actuated pressure reducing regulator
- 1/2" SAE x 1/8" NPTF adaptor is used to connect controller to regulator
- External Feedback control mode
- Feedback source is a two-wire 4–20 mA transducer
- Controller is connected to a PC which is running the ERTune™ program, connected via USB using the Mini-B USB port on the ER5000's control board

For information on other applications and alternative wiring configurations, refer to the *Installation Variations* section.

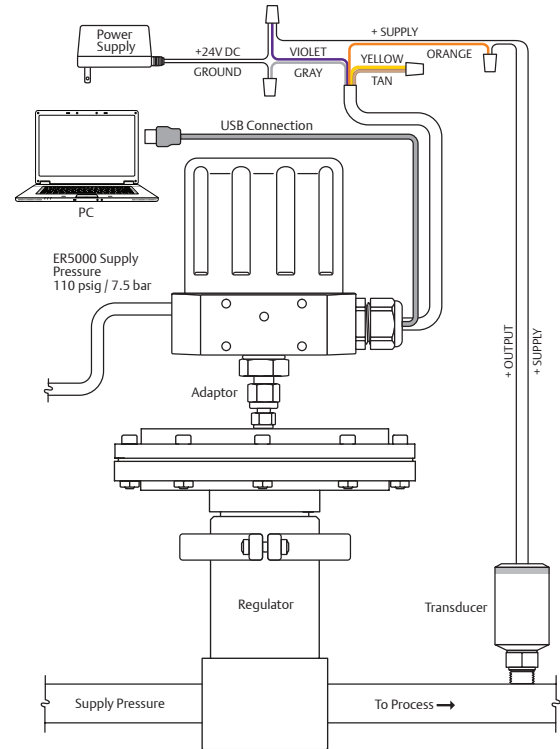

Figure 7: Typical Application Setup of the ER5000

3

Verify that all operational requirements have been met

- Supply pressure must be clean, dry inert gas or instrument grade air that meets the requirements of ISA Standard 7.0.01.
- Install filters upstream of the mechanical regulator, as well as the ER5000, to prevent contamination and excess moisture from entering either device.
- Check that all supply lines, fittings, connections, filters, valves and gauges have adequate pressure ratings for the operating conditions.
- Check that the mechanical regulator's dome port mates correctly with the 1/2" SAE x 1/8" NPTF adaptor. Additional fittings may be required.
- Follow the appropriate industrial standards for the intended function.

Verify that all safety requirements have been met



Read and be sure you understand, all warnings and cautions in the Safety, Installation & Operations Precautions section.

WARNING

- **Improper selection, improper installation, improper maintenance, misuse or abuse of this controller or related accessories can cause property damage, serious injury or death.**
- **Supply pressure must be clean, dry inert gas or air that meets the requirements of ISA Standard 7.0.01.**
- **Severe personal injury or property damage may occur from an uncontrolled process if the instrument supply medium is not clean, dry, oil free, nonflammable and noncorrosive. While use and regular maintenance of a filter that removes particles larger than 40 micrometers in diameter will suffice in most applications, further filtration down to 10 micrometer particle size is recommended. Moisture should be kept to a minimum.**

WARNING

Installation in a hazardous location requires additional steps not described in this section. Refer to *Installing a Hazardous Location Model (ER5050)* on page 110 for more information.

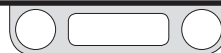

ER5000 — Getting Started

4

Mount the ER5000 on the regulator

NOTE Your application may require additional fittings.

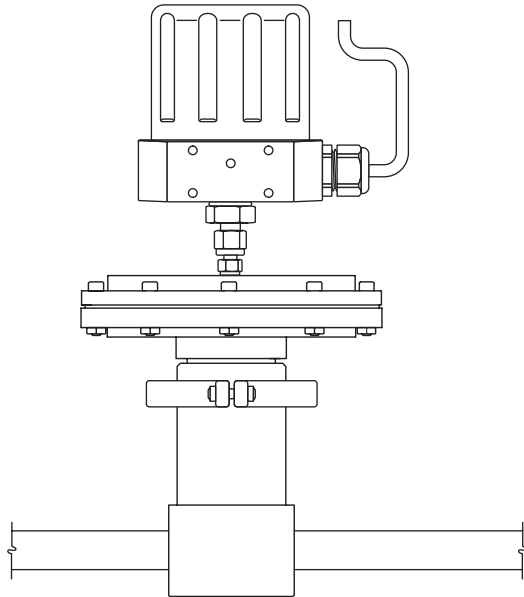
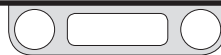

Figure 8: Mount the ER5000 on the Regulator

WARNING

Installation in a hazardous location requires additional steps not described in this section. Refer to *Installing a Hazardous Location Model (ER5050)* on page 110 for more information.



5

Connect and verify the power supply

The ER5000 requires a 24V DC power supply, such as the TESCOM™ 82575-25 or 82575-50 power supply unit.

WARNING

- Select wiring and/or cable glands that are rated for the environment of use. Failure to use properly rated wiring and/or cable glands can result in personal injury or property damage.
- Wiring connections must be in accordance with local, regional and national codes for any given area. Failure to follow the local, regional and national codes could result in personal injury or property damage.
-  To avoid personal injury resulting from electrical shock, never connect the controller or associated equipment to a supply source having a voltage greater than the maximum rated voltage of this controller or the associated equipment. Make sure that the components used in the electronic system are compatible with and have the proper voltage rating.

WARNING

Installation in a hazardous location requires additional steps not described in this section. Refer to *Installing a Hazardous Location Model (ER5050)* on page 110 for more information.

(continued next page)

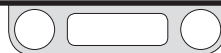

ER5000 — Getting Started

Connect and verify the power supply (cont.)

1. Refer to Table 2 below and Figure 9 to verify correct wiring.

Table 2: Main Cable Wiring for Power Supply

J3 Pins	Wire Color	Function
1	brown	+setpoint input
2	red	-setpoint input
3	orange	+feedback input
4	yellow	-feedback input
5	green	-RS485 network connection
6	blue	+RS485 network connection
7	violet	+24V DC power
8	gray	24V return (power ground)
9	white	+5V output (5 mA max.)
10	black	analog signal/board ground
*11	*pink	analog signal output (active in Enhanced "F" models ONLY)
12	tan	analog signal/board ground

Standard Installation

2. For standard model ER5000s, the 12-pin MTA connector comes pre-installed to the J3 terminal block. For "F" model ER5000s, the standard 12-pin MTA connector and auxiliary 8-pin MTA connector come pre-installed to the J3 and J4 blocks.
3. Connect the violet wire (Pin 7) to the +24V DC wire from the power supply.
4. Connect the gray wire (Pin 8) to the ground wire from the power supply.
5. Plug in the power supply.

(continued next page)

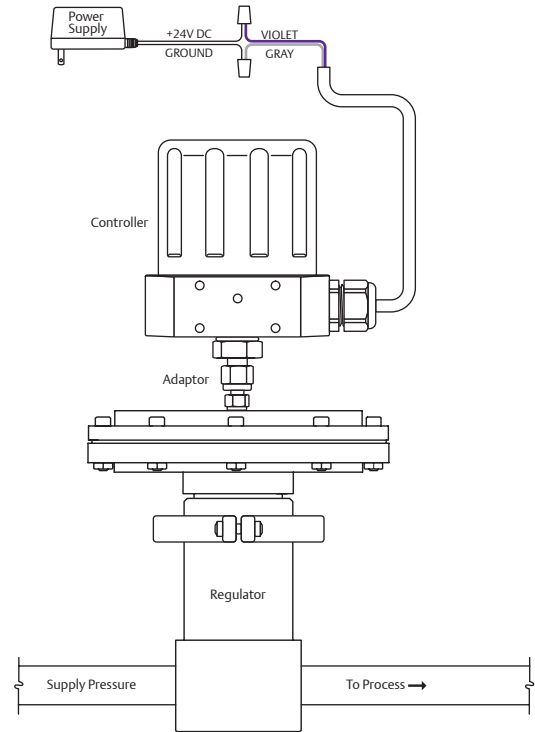
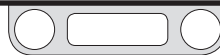

Figure 9: Connect the ER5000 to the Power Supply



ER5000 — Getting Started

Connect and verify the power supply (cont.)

WARNING

DO NOT open cover when an explosive atmosphere is present. Doing so can result in property damage, serious injury or death. Refer to *Installing a Hazardous Location Model (ER5050)* on page 110 for more information.

6. Unscrew and remove the cover of the ER5000 to view the control board. Refer to Figure 10.
7. Check that the Power Indicator LED (LED1) is lit, which indicates power is being supplied.
8. Check that the “Heartbeat” LED (LED4) blinks, which indicates that the embedded controller software is running.

NOTE LED2 (green) and LED3 (amber) respond to data transmission when the ER5000 communicates using RS485. These LEDs do not respond to data transmission when the ER5000 communicates using USB and may be on or off depending on the specific configuration of your application. They do not need to be checked during installation or operation when USB is used.

9. Unplug the power supply.

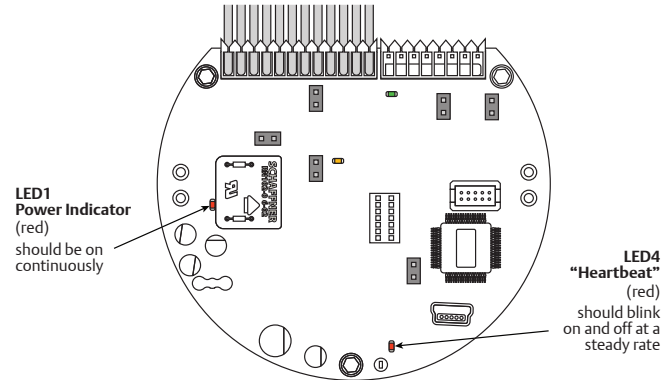
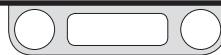

Figure 10: These LEDs Indicate That the ER5000 Has Been Successfully Connected to the Power Supply



6

Verify the Jumper J6 configuration

⚠ WARNING

⚠ The controller must be disconnected from the power supply before any additional wiring or change to jumper configuration is performed. Do not reconnect the power supply until all additional wiring connections have been made and are properly installed.

⚠ WARNING

DO NOT open cover when an explosive atmosphere is present. Doing so can result in property damage, serious injury or death. Refer to *Installing a Hazardous Location Model (ER5050)* on page 110 for more information.

NOTE If you are replacing an ER3000 in an existing application and wish to continue using your current software such as the Windows Tune program, **you will need to install Jumper J9**. The default configuration for Jumper J9 is NOT installed.

With the cover still removed, inspect Jumper J6. Refer to Figure 11.

- For connection to a 4–20 mA transducer, the jumper should be installed.
- For connection to a 1–5V transducer, the jumper should **NOT** be installed.

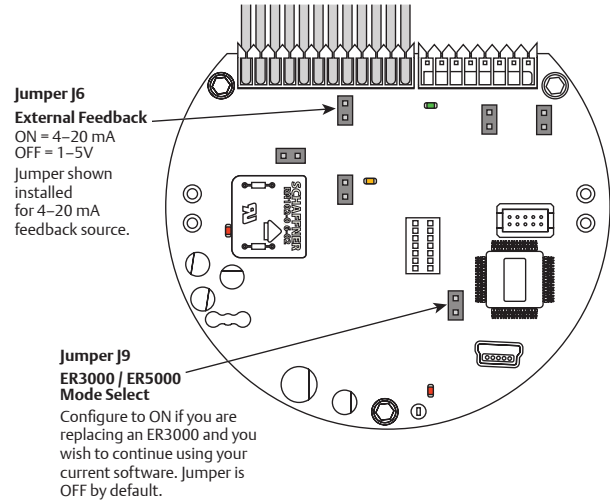

Figure 11: Inspect Configuration of J6 Jumper

7

Connect the transducer wiring to provide a feedback signal

⚠ WARNING

⚡ The controller must be disconnected from the power supply before any additional wiring or change to jumper configuration is performed. Do not reconnect the power supply until all additional wiring connections have been made and are properly installed.

⚠ WARNING

Installation in a hazardous location requires additional steps not described in this section. Refer to *Installing a Hazardous Location Model (ER5050)* on page 110 for more information.

1. Refer to Table 3 below to verify correct wiring.

Table 3: Main Cable Wiring for Power Supply

J3 Pins	Wire Color	Function
1	brown	+setpoint input
2	red	-setpoint input
3	orange	+feedback input
4	yellow	-feedback input
5	green	-RS485 network connection
6	blue	+RS485 network connection
7	violet	+24V DC power
8	gray	24V return (power ground)
9	white	+5V output (5 mA max.)
10	black	analog signal/board ground
*11	*pink	analog signal output (active in Enhanced "F" models ONLY)
12	tan	analog signal/board ground

Standard Installation

(continued next page)

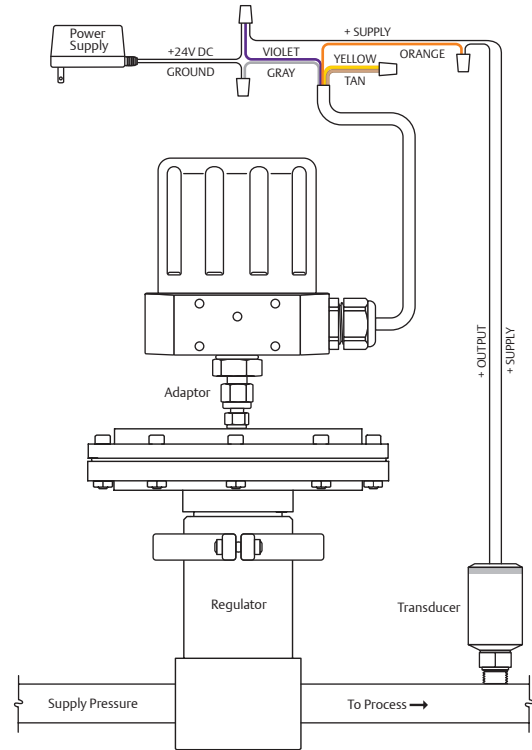



Figure 12: Connect the ER5000 to External Transducer

ER5000 — Getting Started

Connect the transducer wiring to provide a feedback signal (cont.)

2. Connect the orange feedback input wire (Pin 3) to the signal output of the transducer, which is Pin 2 or B on TESCOTM transducers.
3. Connect the positive wire from the 24V DC power supply to the power input of the transducer, which is Pin 1 or A on TESCOTM transducers.
4. Connect the yellow feedback return wire (Pin 4) to the tan analog ground wire (Pin 12).

 **NOTE** This is necessary to complete the ground circuit for the signal from the transducer.

For other applications and wiring configurations, refer to the Installation Variations section.



ER5000 — Getting Started

8

Connect the USB cable (not supplied with ER5050)

⚠ WARNING

⚠ The controller must be disconnected from the power supply before any additional wiring or change to jumper configuration is performed. Do not reconnect the power supply until all additional wiring connections have been made and are properly installed.

⚠ WARNING

Refer to *Installing a Hazardous Location Model (ER5050)* on page 110 for more information on wiring in a Hazardous Location application. Refer to page 89 through page 93 for correct wiring variations using RS485.

The cable included with the ER5000 has a standard USB A connector on one end and a 90° Mini-B connector on the other.

1. Slide the Mini-B connector into the left conduit port in the base of the ER5000 as shown in Figure 13.
2. Thread the cable over the control board and plug it into the Mini-B USB port.
3. Remove any excess slack in the cable and secure the integrated strain relief into the conduit port.
4. Plug the cable's USB A connector into the computer that will run the ERTune™ program.
5. Screw the cover back onto the ER5000 until you have a tight fit and plug in the power supply.

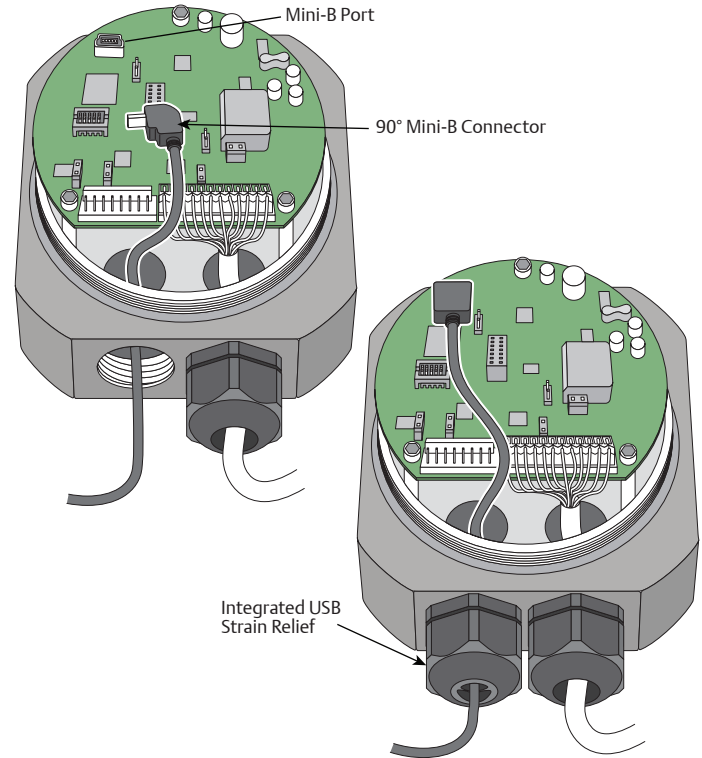

Figure 13: Connect the USB Cable

ER5000 — Getting Started

9

Install the ERTune™ program

IMPORTANT! If you are using Windows 8, be sure you have read the note at the end of Step 1.

1. You will need to have the following information on hand when you start the program for the first time:
 - The model number of your ER5000, which is located on the label of the controller.
 - The series number, part number and serial number of the regulator you are using.
 - The range of your external feedback transducer.
2. Download the ER5000 Software and Manual file which can be found at TESCOM.com under the “Download ER5000 Software and Manual” link. Once the file is downloaded, extract the zip file, click on the .exe file, and the ER5000 User Support Software and Manual menu will open.
3. In the menu, click Install ERTune. When installation is complete, click Close.

NOTE The ERTune™ program is available in English, German and Chinese versions. When installation begins, the installer checks the default language settings for the computer and if German or Chinese are detected, the corresponding translated version is installed. Otherwise, the English version is installed.

4. Locate the ERTune program listing in the Start menu and open it.

5. The ER5000 Setup Wizard screens are shown in Figure 14. Use the information from Step 1 to complete setup. For most screens, the default values will be correct for your application.
6. Tune the ER5000 according to the instructions in The ERTune™ Program: Basic Features section.

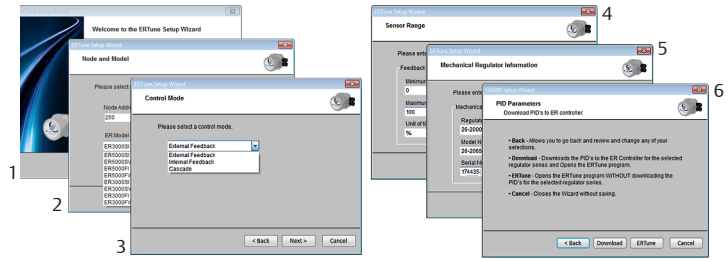
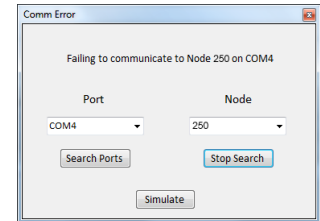

Figure 14: Setup Sequence for ERTune™ Software

NOTE If you see the Communication Error window, as shown in Figure 15, click the Search Ports button. If the program does not start, refer to the Troubleshooting section.

Figure 15: The Comm Error (Communication Error) Window



10

Connect pressure to the system

⚠ WARNING

- ⚠ Never connect the controller or any associated equipment to a supply source having a pressure greater than the maximum rated pressure of this controller or the associated equipment.
- Supply pressure must be clean, dry inert gas or air that meets the requirements of ISA Standard 7.0.01.
- The ER5000 exhausts pilot pressure to the surrounding atmosphere. When installing this unit in a confined area, the exhaust port should be remotely vented to a safe location to prevent asphyxiation due to lack of Oxygen in the surrounding atmosphere.

Connect the inlet pressure source to the Inlet Port, marked IN on the base of the ER5000. Refer to Figure 16.

- The Exhaust Port vents to atmosphere.
- The output pressure is the regulated pressure that passes through the Outlet Port on the bottom of the controller into the dome of the regulator. Refer to Dimensions – Top and Bottom View.

(continued next page)

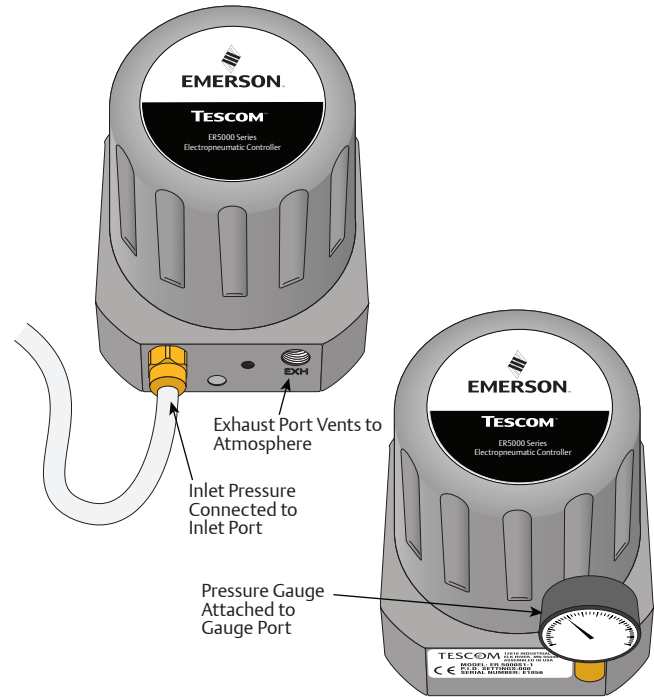
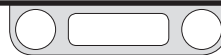

Figure 16: Pressure Connections



ER5000 — Getting Started

Connect pressure to the system (cont.)

- c. Leave the Gauge Port plugged to prevent leakage or attach a pressure gauge, as shown in Figure 16 on the previous page.

NOTE For side-mounted applications, the Gauge Port can be used as the outlet. Plug the Outlet Port at the bottom of the controller for these applications.



11

Start up and tune the system

WARNING

- Start up sequence for electropneumatic controllers is:
 - a. Feedback loop must be installed and operational.
 - b. Electrical power should be applied and system setpoint reduced to its lowest pressure output before turning on the pneumatic supply to the controller.
 - c. Apply pressure to the system gradually, avoiding a sudden surge of fluid or pressure shock to the equipment in the system.
- To avoid personal injury and property damage, keep hands, tools and other objects away when applying power to the controller.
- Changes to the instrument setup may cause changes in the output pressure. Depending on the application, these changes may upset process control, which may result in personal injury or property damage.
- Most controls in the ERTune™ program operate in real time and have an immediate effect on system performance. Be aware of system limitations before you change the settings of a control. Depending on the application, these changes may upset the process control, which may result in personal injury or property damage.

The ER5000 is now fully installed. Connect the regulator supply pressure to the Inlet Port of the regulator.

The system performance can be checked and, if desired, optimized further using the ERTune™ program.

Refer to The ERTune™ Program: Basic Features section for further details and recommendations on tuning the pressure control system.

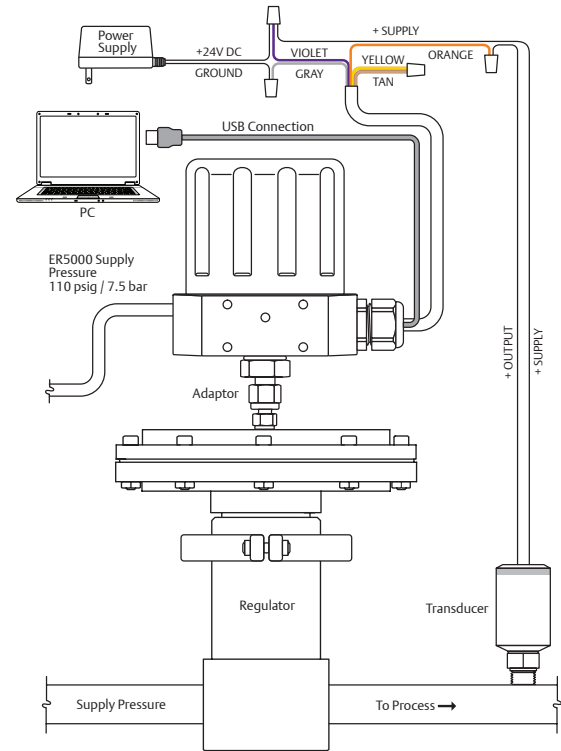

Figure 17: The Completed ER5000 Installation



INSTALLATION VARIATIONS



ER5000 — Installation Variations

Before You Begin

WARNING



Investigate and apply the most recent standards for Hazardous Locations for your area set by ANSI, ISO and OSHA, as well as all electrical codes and fire and safety standards, to determine if your application will require a Hazardous Location model. If your application requires a Hazardous Location model (ER5050), refer to *Installing a Hazardous Location Model (ER5050)* on page 110 before following the steps listed in this section.

WARNING

Avoid personal injury or property damage from sudden release of pressure or bursting parts. Before proceeding with any installation procedures:



- Always wear protective clothing, gloves and eyewear to prevent personal injury or property damage.
- Do not remove the ER5000 or any other component of the system while the system is pressurized.



- Disconnect any operating lines providing air pressure, electric power or a control signal to the ER5000 prior to installation or maintenance.

- Use bypass valves or completely shut off the process to isolate the ER5000 and associated equipment from process pressure prior to installation or maintenance. Relieve process pressure on both sides of the controller and associated equipment.



- Use lock-out procedures to be sure that the above measures stay in effect while you work on the equipment.
- Check with your process or safety engineer for any additional measures that must be taken to protect against process media dangers.



Do not install, operate or maintain an ER5000 controller or any associated equipment, without reading and fully understanding the installation guidelines and operating instructions for every component of your application. To avoid personal injury or property damage, it is important to carefully read, understand and follow all contents of this manual, including all safety cautions and warnings in the Safety, Installation & Operations Precautions section. If you have any questions about these instructions, contact your TESCOTM sales office before proceeding.

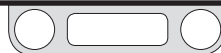

ER5000 — Installation Variations

ER5000 Installation Variations — Wiring Diagrams

The ER5000 has a wide range of wiring options, allowing it to be configured for virtually any application requirement. If your application calls for a variation on the standard installation, use the diagrams on the following pages to build a complete configuration. Note that in your actual application, multiple wires may terminate at the same connection: for example, the violet wire (Pin 7), which is the (+) connection to the power source, may also connect directly to the transducer or other external devices.

If your application requires a Hazardous Location model (ER5050), read *Installing a Hazardous Location Model (ER5050)*, pages 110-111, for the following information.

Step 1: Connect the ER5000 to a 24V DC Power Supply

All wiring configurations begin by connecting the ER5000 to a 24V DC power supply. The external power supply is necessary for the controller to operate **and is part of all applications.**

Power Supply [page 82](#)

NOTE This section shows variations to the typical ER5000 configuration described in the Getting Started section.

NOTE The (+) and the (-) in the tables and figures of this section refer to the differential inputs. Both must be connected for the system to work properly.

NOTE Setpoint is set digitally by writing to variable #37 (ID_SETPOINT), using the ERTune™ program or your own coding. Refer to the Internal Variables and the ER5000 Software Development Support sections for more information.

Step 2: Connect the Setpoint and Feedback Source

Setpoint and feedback sources vary with application. Use the links below to match the setpoint and feedback sources for your application to specific wiring diagrams and descriptions in this section. Click a page number to go to that diagram; click the **BACK** button to return to this page.

Setpoint Source

Profile	None
Analog (Potentiometer)	page 83
Analog (Current/Voltage)	page 84
Analog (Passive PC or PLC D/A Card)	page 85
Analog (Active PC or PLC D/A Card)	page 86
Profile with External Control	page 87
Digital (RS232 to RS485 Converter)	page 89
Digital (USB to RS485 Converter)	page 90
Digital (RS232 to RS485 Network)	page 91
Digital (USB to RS485 Network)	page 93
Digital (USB)	USB cable

Feedback Source

Internal	None
Two Wire Transducer	page 95
Three Wire Transducer	page 96
Four Wire Transducer	page 97
4–20 mA External Feedback, Floating Input, Feedback Signal Monitored by PC or PLC A/D Card	page 98
4–20 mA External Feedback, Ground Referenced Input, Feedback Signal Monitored by PC or PLC A/D Card	page 99
Two Wire Transducer, PC/PLC Used to Monitor Voltage Through ER5000 Internal Resistor	page 100
Three Wire Transducer, PC/PLC Used to Monitor Voltage Through ER5000 Internal Resistor	page 101
Four Wire Transducer, PC/PLC Used to Monitor Voltage Through ER5000 Internal Resistor	page 102
Switch Feedback Control to a Second Feedback Source	page 103

Step 3: If Applicable, Connect Wiring for Additional Functions

Some applications call for monitoring and control connections in addition to the standard trio of power, setpoint and feedback.

Monitoring Additional Analog Inputs	page 104
Monitoring the Internal Sensor, 4–20 mA Wiring	page 105
Monitoring the Internal Sensor, 0–10V Wiring	page 106
Digital Outputs	page 107
Suspend Mode	page 109

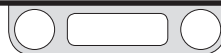

ER5000 — Installation Variations

Terminal Blocks and Wires

There are two terminal blocks on the control board of the ER5000. The 12-pin J3 terminal block is active for all models of the controller. The auxiliary 8-pin J4 terminal block is only active for “F” model controllers.

All ER5000s feature a 12-pin MTA connector to the J3 terminal block. “F” model ER5000s also feature an auxiliary 8-pin MTA connector to the J4 terminal block.

Previous versions of the “F” model controller featured separate cables for the standard and auxiliary connectors. For “F” model ER5000s, both connectors are fed by a single 20-wire cable.

Wires are color coded for easy identification. Wires that feed the J3 terminal block are solid colors and wires that feed the J4 block are color striped, as shown in Figure 18.

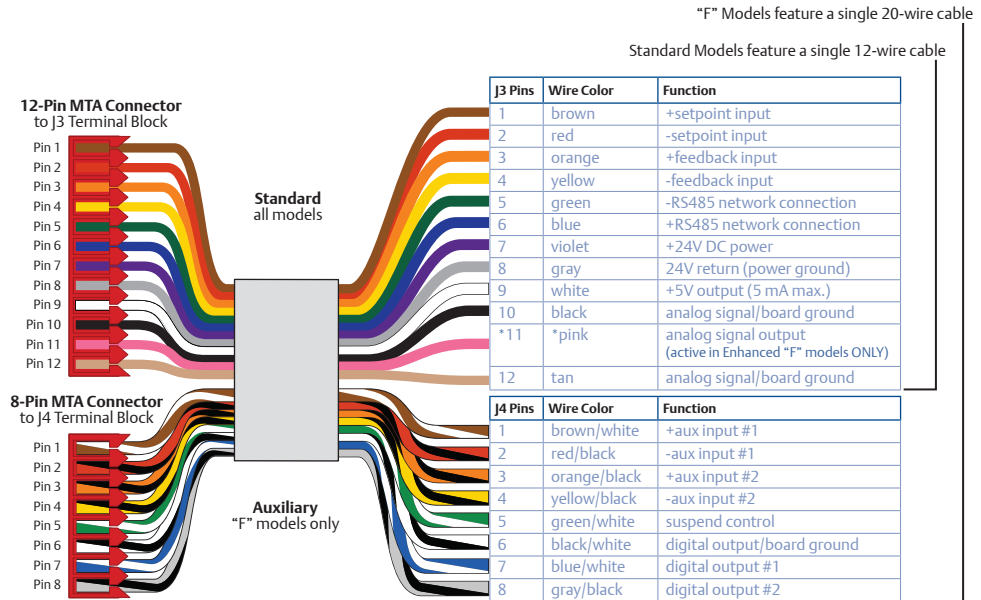

Figure 18: Wires and Terminal Block Pins

ER5000 — Installation Variations

Voltage/Current Select Jumpers

⚠ WARNING

⚠ The controller must be disconnected from the power supply before any additional wiring or change to jumper configuration is performed. Do not reconnect the power supply until all additional wiring connections have been made and are properly installed.

NOTE If you are replacing an ER3000 in an existing application and wish to continue using your current software such as the Windows Tune program, **you will need to install Jumper J9**. The default configuration for Jumper J9 is NOT installed.

Figure 19 shows the voltage/current select jumpers on the ER5000.

Jumpers J5, J6, J14 and J15 are used to select between 4–20 mA and 1–5V sources for setpoint, external feedback, auxiliary input #1 and auxiliary input #2 respectively. For these jumpers, having the jumper installed (ON) configures the controller for 4–20 mA input and having the jumper not installed (OFF) configures the controller for 1–5V input.

NOTE 0–10V models of the ER5000 do not have these jumpers.

(continued next page)

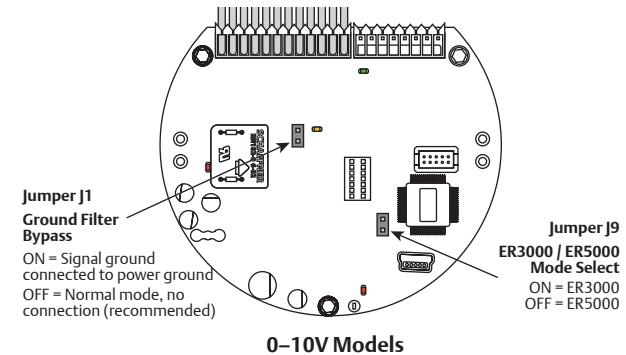
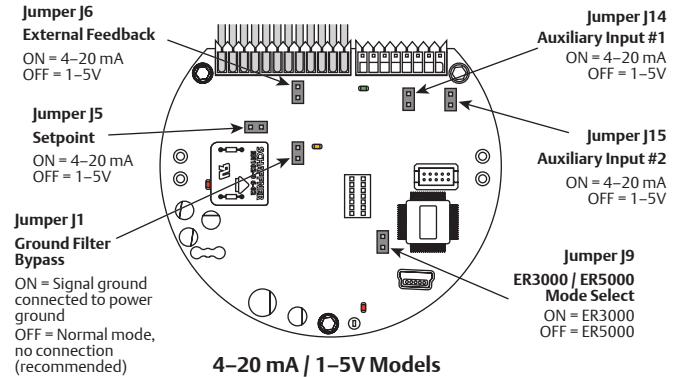

Figure 19: Jumpers

ER5000 — Installation Variations

The recommended configuration for the Ground Filter Bypass jumper (J1) is not installed (OFF). Installing this jumper connects signal ground directly to the power supply ground. This configuration is rarely used and should only be considered when there is an extreme level of operational noise. Refer to the Troubleshooting section before installing this jumper.

LED Indicators

Figure 20 shows the position of the four LED indicators on the circuit board of the ER5000. The LED indicators give you a quick visual reference to evaluate the status of the controller.

During installation, use LED1 (red) and LED4 (red) to verify that you have correctly wired the ER5000 to its power supply.

If you are communicating via RS485, for example as part of a daisychain on a network, LED2 (green) and LED3 (amber) verify that the ER5000 is sending and receiving data.

NOTE Refer to page 89 through page 93 for correct wiring to connect the ER5000 to an RS485 converter.

NOTE LED2 and LED3 respond to data transmission when the ER5000 communicates using RS485. These LEDs do not respond to data transmission when the ER5000 communicates using USB and may be on or off depending on the specific configuration of your application. They do not need to be checked during installation or operation when USB is used.

The LEDs can help you troubleshoot controllers that are not functioning properly. For further information, refer to the Troubleshooting section.

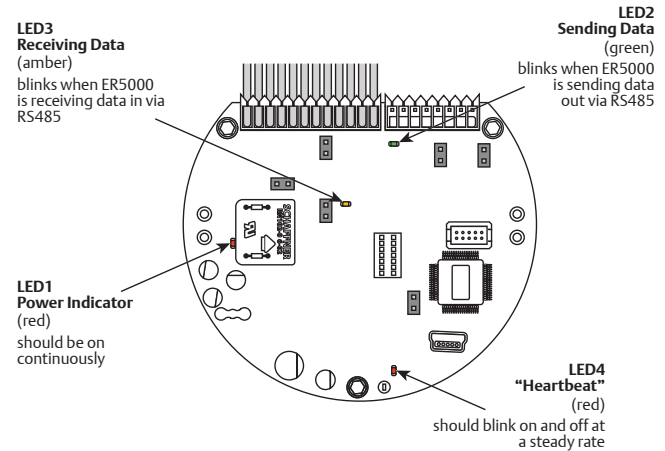
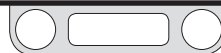

Figure 20: LED Indicators



ER5000 — Installation Variations

Power Supply Wiring — All Applications

All ER5000s, regardless of configuration or application, must first be wired to a 24V DC power supply, as shown in Figure 21.

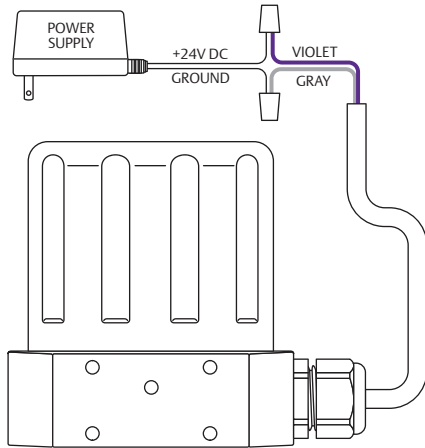

Figure 21: Wiring to 24V DC Power Supply

Refer to Table 4 to verify correct wiring.

Table 4: Wiring to 24V DC Power Supply

J3 Pins	Wire Color	Function
1	brown	+setpoint input
2	red	-setpoint input
3	orange	+feedback input
4	yellow	-feedback input
5	green	-RS485 network connection
6	blue	+RS485 network connection
7	violet	+24V DC power
8	gray	24V return (power ground)
9	white	+5V output (5 mA max.)
10	black	analog signal/board ground
*11	*pink	analog signal output (active in Enhanced *F* models ONLY)
12	tan	analog signal/board ground

⚠ WARNING

- Select wiring and/or cable glands that are rated for the environment of use. Failure to use properly rated wiring and/or cable glands can result in personal injury or property damage.
- Wiring connections must be in accordance with local, regional and national codes for any given area. Failure to follow the local, regional and national codes could result in personal injury or property damage.
- ⚠ To avoid personal injury resulting from electrical shock, never connect the controller or associated equipment to a supply source having a voltage greater than the maximum rated voltage of this controller or the associated equipment. Make sure that the components used in the electronic system are compatible with and have the proper voltage rating.

ER5000 — Installation Variations

Setpoint Wiring Variations

Analog Setpoint Source — Potentiometer

Figure 22 shows correct wiring to provide a 0–5V signal to the analog setpoint from a potentiometer.

NOTE The 0–1V range can be programmed as a Control Limit for 1–5V ER5000s. Refer to The Control Limits Panel for more information on this feature.

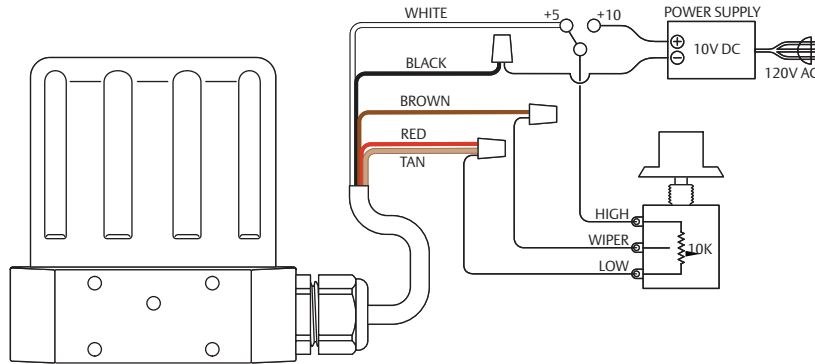

Figure 22: Potentiometer Analog Setpoint

⚠ WARNING

⚠ The controller must be disconnected from the power supply before any additional wiring or change to jumper configuration is performed. Do not reconnect the power supply until all additional wiring connections have been made and are properly installed.

Refer to Table 5 to verify correct wiring.

Table 5: Wiring for Potentiometer Analog Setpoint

J3 Pins	Wire Color	Function
1	brown	+setpoint input
2	red	-setpoint input
3	orange	+feedback input
4	yellow	-feedback input
5	green	-RS485 network connection
6	blue	+RS485 network connection
7	violet	+24V DC power
8	gray	24V return (power ground)
9	white	+5V output (5 mA max.)
10	black	analog signal/board ground
*11	*pink	analog signal output (active in Enhanced "F" models ONLY)
12	tan	analog signal/board ground

NOTE The ER5000 cannot directly provide a 0–10V signal. An external 10V supply must be used.

ER5000 — Installation Variations

Setpoint Wiring Variations

Analog Setpoint Source — Current/Voltage

Figure 23 shows how to provide the analog setpoint from an active variable current or voltage supply.

The negative (-) lead of your source connects to the red wire and the positive (+) lead connects to the brown wire.

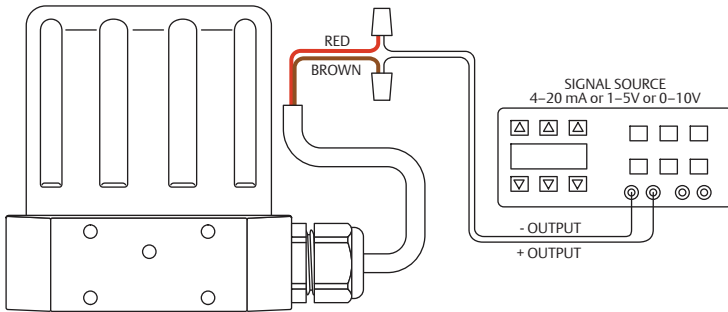

Figure 23: Current/Voltage Analog Setpoint

⚠ WARNING



The controller must be disconnected from the power supply before any additional wiring or change to jumper configuration is performed. Do not reconnect the power supply until all additional wiring connections have been made and are properly installed.

Refer to Table 6 to verify correct wiring.

Table 6: Wiring for Current/Voltage Analog Setpoint

J3 Pins	Wire Color	Function
1	brown	+setpoint input
2	red	-setpoint input
3	orange	+feedback input
4	yellow	-feedback input
5	green	-RS485 network connection
6	blue	+RS485 network connection
7	violet	+24V DC power
8	gray	24V return (power ground)
9	white	+5V output (5 mA max.)
10	black	analog signal/board ground
*11	*pink	analog signal output (active in Enhanced "F" models ONLY)
12	tan	analog signal/board ground



ER5000 — Installation Variations

Setpoint Wiring Variations

Analog Setpoint Source — Passive PC or PLC D/A Card

Figure 24 shows correct wiring to provide an analog setpoint from a PC or PLC D/A card. In this configuration, the ER5000's 24V DC power supply supplies power to the passive D/A card.

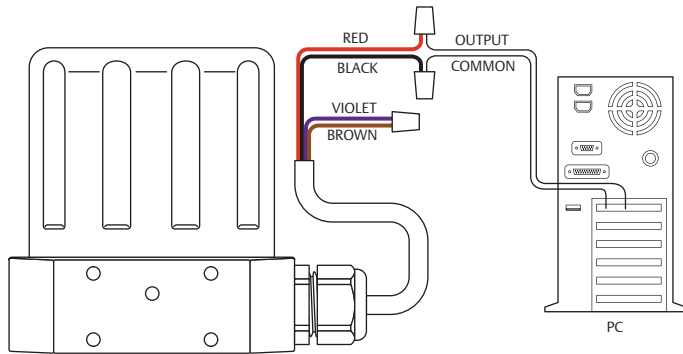

Figure 24: Passive PC or PLC D/A Card Analog Setpoint

⚠ WARNING



The controller must be disconnected from the power supply before any additional wiring or change to jumper configuration is performed. Do not reconnect the power supply until all additional wiring connections have been made and are properly installed.

Refer to Table 7 to verify correct wiring.

Table 7: Wiring for Passive PC or PLC D/A Card Analog Setpoint

J3 Pins	Wire Color	Function
1	brown	+setpoint input
2	red	-setpoint input
3	orange	+feedback input
4	yellow	-feedback input
5	green	-RS485 network connection
6	blue	+RS485 network connection
7	violet	+24V DC power
8	gray	24V return (power ground)
9	white	+5V output (5 mA max.)
10	black	analog signal/board ground
*11	*pink	analog signal output (active in Enhanced "F" models ONLY)
12	tan	analog signal/board ground

NOTE Check that Jumper J6 (refer to Figure 19) is installed for 4–20 mA operation and removed for 1–5V operation. There is no jumper on the 0–10V ER5000 models.



ER5000 — Installation Variations

Setpoint Wiring Variations

Analog Setpoint Source — Active PC or PLC D/A Card

Figure 25 shows correct wiring to provide an analog setpoint from a PC or PLC D/A card. In this configuration, the power is supplied by the active D/A card.

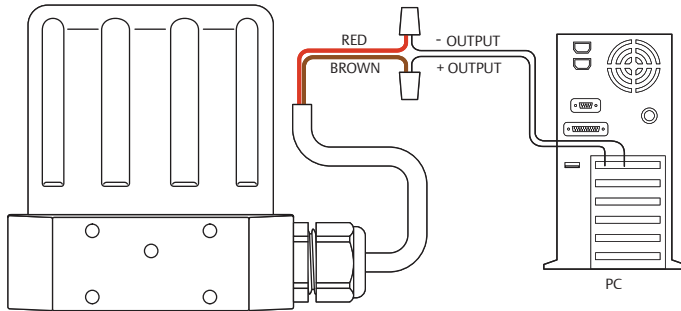

Figure 25: Active PC or PLC D/A Card Analog Setpoint

⚠ WARNING



The controller must be disconnected from the power supply before any additional wiring or change to jumper configuration is performed. Do not reconnect the power supply until all additional wiring connections have been made and are properly installed.

Refer to Table 8 to verify correct wiring.

Table 8: Wiring for Active PC or PLC D/A Card Analog Setpoint

J3 Pins	Wire Color	Function
1	brown	+setpoint input
2	red	-setpoint input
3	orange	+feedback input
4	yellow	-feedback input
5	green	-RS485 network connection
6	blue	+RS485 network connection
7	violet	+24V DC power
8	gray	24V return (power ground)
9	white	+5V output (5 mA max.)
10	black	analog signal/board ground
*11	*pink	analog signal output (active in Enhanced "F" models ONLY)
12	tan	analog signal/board ground

NOTE Check that **Jumper J6** (refer to Figure 19) is installed for 4–20 mA operation and removed for 1–5V operation. There is no jumper on the 0–10 Volt ER5000 models.

ER5000 — Installation Variations

Setpoint Wiring Variations

Profile with External Control/Digital Inputs

NOTE This feature is only available on “F” models of the ER5000.

NOTE Jumpers J14 and J15 must be removed for this application. Refer to Figure 19.

Figure 26 shows the wiring configuration for controlling a Profile without using a PC. The Profile that has been downloaded into the ER5000 in this application can be started or stopped with a toggle switch.

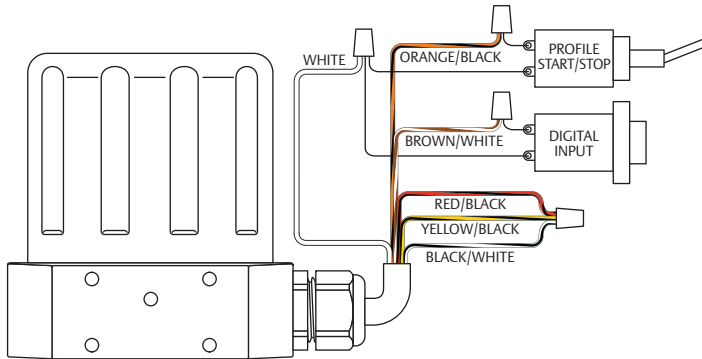

Figure 26: External Profile Control

⚠ WARNING



The controller must be disconnected from the power supply before any additional wiring or change to jumper configuration is performed. Do not reconnect the power supply until all additional wiring connections have been made and are properly installed.

Refer to Table 9 to verify correct wiring.

Table 9: Wiring for Profile Control Using Auxiliary Inputs

J3 Pins	Wire Color	Function
1	brown	+setpoint input
2	red	-setpoint input
3	orange	+feedback input
4	yellow	-feedback input
5	green	-RS485 network connection
6	blue	+RS485 network connection
7	violet	+24V DC power
8	gray	24V return (power ground)
9	white	+5V output (5 mA max.)
10	black	analog signal/board ground
*11	*pink	analog signal output (active in Enhanced “F” models ONLY)
12	tan	analog signal/board ground

J4 Pins	Wire Color	Function
1	brown/white	+aux input #1
2	red/black	-aux input #1
3	orange/black	+aux input #2
4	yellow/black	-aux input #2
5	green/white	suspend control
6	black/white	digital output/board ground
7	blue/white	digital output #1
8	gray/black	digital output #2

(continued next page)

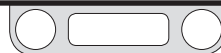

ER5000 — Installation Variations

Profile with External Control/Digital Inputs (cont.)

Additionally, the Digital Input push button can be used if the “Digital Input” function has been used within the Profile. This allows an operator the flexibility to wait until an event has occurred, such as changing to the next device.

When Auxiliary Input #2 (orange/black wire, J4 Pin 3) is used as the Profile Start/Stop signal and Auxiliary Input #1 (brown/white wire, J4 Pin 1) is used as the Digital Input signal, the ER5000 allows you to adjust the toggle level (also referred to as the trip point) of the input. This is the level where the analog input switches between a logical 0 and a logical 1.

For example, when a pressure transducer is connected to the Digital Input, this feature allows the ER5000 to wait for a specific pressure before continuing on in the Profile.

The ER5000 toggle variables enable this feature. Refer to the ER5000 Analog Input Variables section for more information.

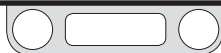

ER5000 — Installation Variations

Setpoint Wiring Variations

Digital Setpoint Source — RS485 Connection, RS232 to RS485 Converter (TESCOM™ Model #85061)

For most applications, the supplied USB cable provides the most efficient connection to the PC. The controller can also be wired to connect through an RS485 converter, as shown in Figure 27.

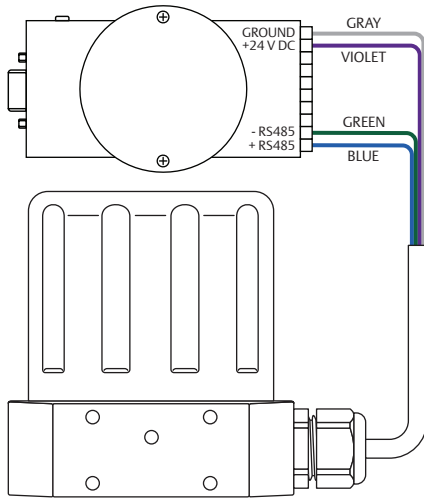

Figure 27: RS485 Connection (RS232 to RS485 Converter)

⚠ WARNING



The controller must be disconnected from the power supply before any additional wiring or change to jumper configuration is performed. Do not reconnect the power supply until all additional wiring connections have been made and are properly installed.

Refer to Table 10 to verify correct wiring.

Table 10: Wiring for RS485 Connection (RS232 to RS485 Converter)

J3 Pins	Wire Color	Function
1	brown	+setpoint input
2	red	-setpoint input
3	orange	+feedback input
4	yellow	-feedback input
5	green	-RS485 network connection
6	blue	+RS485 network connection
7	violet	+24V DC power
8	gray	24V return (power ground)
9	white	+5V output (5 mA max.)
10	black	analog signal/board ground
*11	*pink	analog signal output (active in Enhanced "F" models ONLY)
12	tan	analog signal/board ground

The RS232 to RS485 converter requires direct wiring to an external power supply, so it must be connected to the ER5000's power supply wiring. The violet wire (Pin 7) connects to the +24V DC terminal and the gray wire (Pin 8) connects to the ground terminal.

ER5000 — Installation Variations

Setpoint Wiring Variations

Digital Setpoint Source — RS485 Connection, USB to RS485 Converter (TESCOM™ Model #82948)

For most applications, the supplied USB cable provides the most efficient connection to the PC. The controller can also be wired to connect through an RS485 converter, as shown in Figure 28.

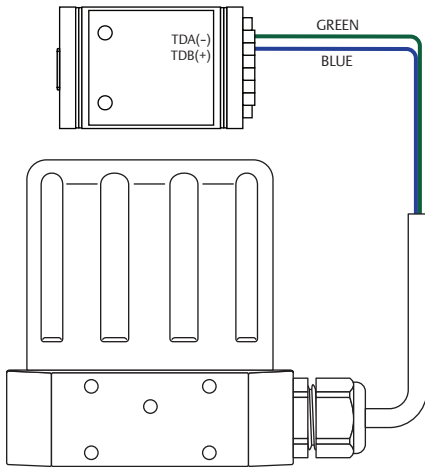

Figure 28: RS485 Connection (USB to RS485 Converter)

⚠ WARNING



The controller must be disconnected from the power supply before any additional wiring or change to jumper configuration is performed. Do not reconnect the power supply until all additional wiring connections have been made and are properly installed.

Refer to Table 11 to verify correct wiring.

Table 11: Wiring for RS485 Connection (USB to RS485 Converter)

J3 Pins	Wire Color	Function
1	brown	+setpoint input
2	red	-setpoint input
3	orange	+feedback input
4	yellow	-feedback input
5	green	-RS485 network connection
6	blue	+RS485 network connection
7	violet	+24V DC power
8	gray	24V return (power ground)
9	white	+5V output (5 mA max.)
10	black	analog signal/board ground
*11	*pink	analog signal output (active in Enhanced "F" models ONLY)
12	tan	analog signal/board ground

The USB to RS485 converter is powered through its USB connection, so it does not require direct wiring to a power supply.

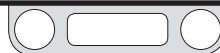

ER5000 — Installation Variations

Setpoint Wiring Variations

Digital Setpoint Source — RS485 Network, RS232 to RS485 Converter (TESCOM™ Model #85061)

The USB protocol isn't networkable, so applications requiring multiple controllers must use RS485. RS485, wired through a converter as shown in Figure 29, allows for up to 32 ER5000s to be daisychained in a network.

⚠ WARNING



The controller must be disconnected from the power supply before any additional wiring or change to jumper configuration is performed. Do not reconnect the power supply until all additional wiring connections have been made and are properly installed.

(continued next page)

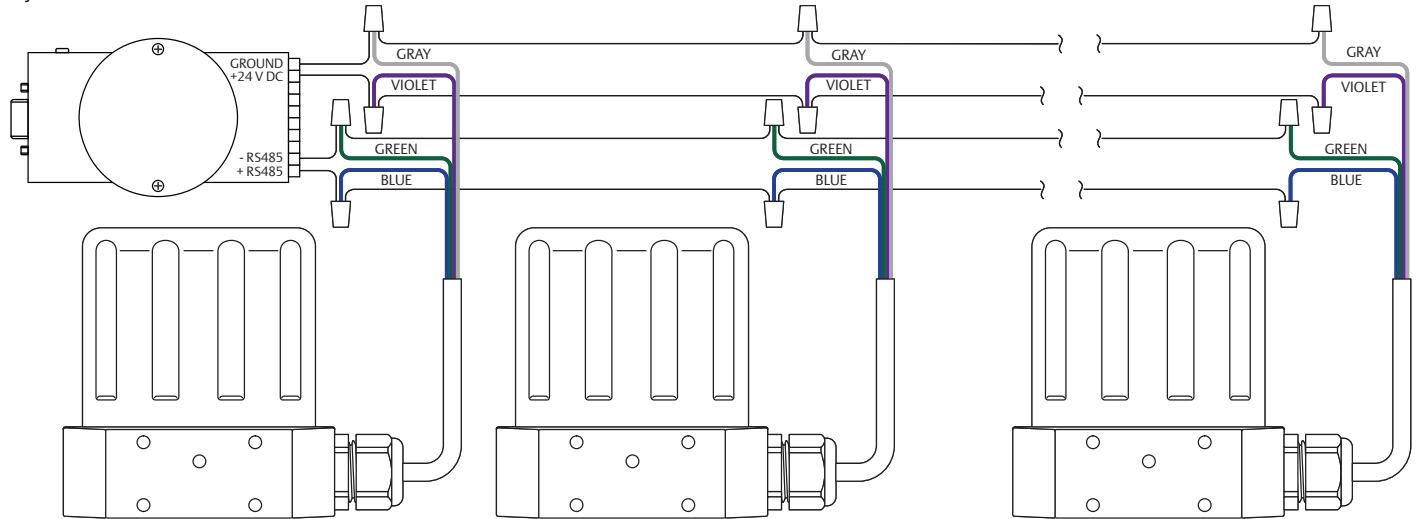

Figure 29: Multiple Controllers in an RS485 Network (RS232 to RS485 Converter)

ER5000 — Installation Variations

Digital Setpoint Source — RS485 Network, RS232 to RS485 Converter (TESCOM™ Model #85061) (cont.)

Each ER5000 in the network must be assigned a unique Node Address. All ER5000s are assigned a default Node Address of 250; therefore, the addresses must be changed to allow them to all communicate on the network.

The Node Address can be changed as part of the setup procedure or at any time afterwards using The Configure Tab.

Refer to To set up the ERTune™ program to work with the ER5000 and The Configure Tab for more information on how to modify the Node Address of the ER5000 using the ERTune™ program.

Repeat this process for each ER5000 in the network. Be sure to give each controller a unique Node Address within the network. You may leave one ER5000 at the default value.

NOTE The number you assign should be lower than 250. Numbers higher than 250 will be truncated to the first two digits.

NOTE The power supply for your network must be able to provide 300 mA to each ER5000 in the daisychain.

Refer to Table 12 to verify correct wiring.

Table 12: Wiring for Networked Connection (RS232 to RS485 Converter)

J3 Pins	Wire Color	Function
1	brown	+setpoint input
2	red	-setpoint input
3	orange	+feedback input
4	yellow	-feedback input
5	green	-RS485 network connection
6	blue	+RS485 network connection
7	violet	+24V DC power
8	gray	24V return (power ground)
9	white	+5V output (5 mA max.)
10	black	analog signal/board ground
*11	*pink	analog signal output (active in Enhanced "F" models ONLY)
12	tan	analog signal/board ground

The RS232 to RS485 converter requires direct wiring to an external power supply, so it must be connected to the ER5000's power supply wiring. The violet wire (Pin 7) connects to the +24V DC terminal and the gray wire (Pin 8) connects to the ground terminal.

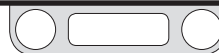

ER5000 — Installation Variations

Setpoint Wiring Variations

Digital Setpoint Source — RS485 Network, USB to RS485 Converter (TESCOM™ Model #82948)

The USB protocol isn't networkable, so applications requiring multiple controllers must use RS485. RS485, wired through a converter as shown in Figure 30, allows for up to 32 ER5000s to be daisychained in a network.

⚠ WARNING



The controller must be disconnected from the power supply before any additional wiring or change to jumper configuration is performed. Do not reconnect the power supply until all additional wiring connections have been made and are properly installed.

(continued next page)

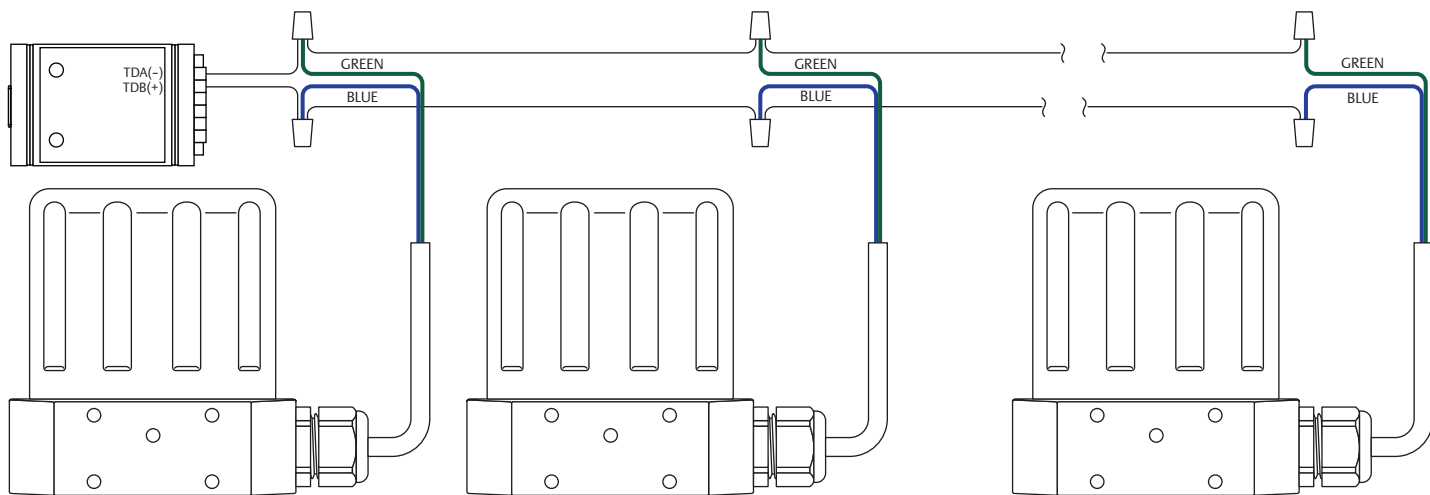

Figure 30: Multiple Controllers in an RS485 Network (USB to RS485 Converter)

ER5000 — Installation Variations

Digital Setpoint Source — RS485 Network, USB to RS485 Converter (TESCOM™ Model #82948) (cont.)

Each ER5000 in the network must be assigned a unique Node Address. All ER5000s are assigned a default Node Address of 250; therefore, the addresses must be changed to allow them to all communicate on the network.

The Node Address can be changed as part of the setup procedure or at any time afterwards using The Configure Tab.

Refer to To set up the ERTune™ program to work with the ER5000 and The Configure Tab for more information on how to modify the Node Address of the ER5000 using the ERTune™ program.

Repeat this process for each ER5000 in the network. Be sure to give each controller a unique Node Address within the network. You may leave one ER5000 at the default value.

NOTE The number you assign should be lower than 250. Numbers higher than 250 will be truncated to the first two digits.

NOTE The power supply for your network must be able to provide 300 mA to each ER5000 in the daisychain.

Refer to Table 13 to verify correct wiring.

Table 13: Wiring for Networked Connection (USB to RS485 Converter)

J3 Pins	Wire Color	Function
1	brown	+setpoint input
2	red	-setpoint input
3	orange	+feedback input
4	yellow	-feedback input
5	green	-RS485 network connection
6	blue	+RS485 network connection
7	violet	+24V DC power
8	gray	24V return (power ground)
9	white	+5V output (5 mA max.)
10	black	analog signal/board ground
*11	*pink	analog signal output (active in Enhanced "F" models ONLY)
12	tan	analog signal/board ground

The USB to RS485 converter is powered through its USB connection, so it does not require direct wiring to a power supply.

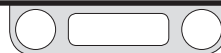

ER5000 — Installation Variations

Feedback Wiring Variations

Two Wire Transducer

The correct wiring for two wire transducers is shown in Figure 31.

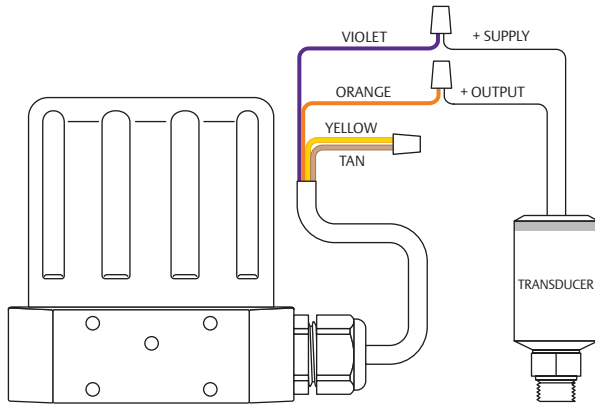

Figure 31: Two Wire Transducer Wiring

⚠ WARNING



The controller must be disconnected from the power supply before any additional wiring or change to jumper configuration is performed. Do not reconnect the power supply until all additional wiring connections have been made and are properly installed.

Refer to Table 14 to verify correct wiring.

Table 14: Wiring for Two Wire Transducer

J3 Pins	Wire Color	Function
1	brown	+setpoint input
2	red	-setpoint input
3	orange	+feedback input
4	yellow	-feedback input
5	green	-RS485 network connection
6	blue	+RS485 network connection
7	violet	+24V DC power
8	gray	24V return (power ground)
9	white	+5V output (5 mA max.)
10	black	analog signal/board ground
*11	*pink	analog signal output (active in Enhanced "F" models ONLY)
12	tan	analog signal/board ground

NOTE Check that Jumper J6 (refer to Figure 19) is installed for 4–20 mA operation.



ER5000 — Installation Variations

Feedback Wiring Variations

Three Wire Transducer

The correct wiring for three wire transducers is shown in Figure 32.

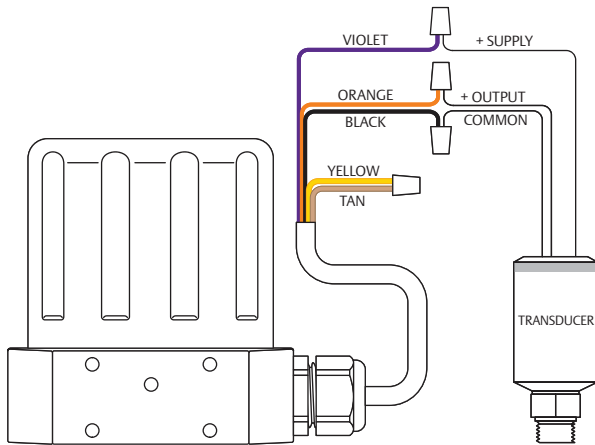

Figure 32: Three Wire Transducer Wiring

⚠ WARNING



The controller must be disconnected from the power supply before any additional wiring or change to jumper configuration is performed. Do not reconnect the power supply until all additional wiring connections have been made and are properly installed.

Refer to Table 15 to verify correct wiring.

Table 15: Wiring for Three Wire Transducer

J3 Pins	Wire Color	Function
1	brown	+setpoint input
2	red	-setpoint input
3	orange	+feedback input
4	yellow	-feedback input
5	green	-RS485 network connection
6	blue	+RS485 network connection
7	violet	+24V DC power
8	gray	24V return (power ground)
9	white	+5V output (5 mA max.)
10	black	analog signal/board ground
*11	*pink	analog signal output (active in Enhanced "F" models ONLY)
12	tan	analog signal/board ground

NOTE Check that Jumper J6 (refer to Figure 19) is installed for 4–20 mA operation and removed for 1–5V operation. There is no jumper on the 0–10V ER5000 models.

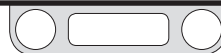

ER5000 — Installation Variations

Feedback Wiring Variations

Four Wire Transducer

The correct wiring for four wire transducers is shown in Figure 33.

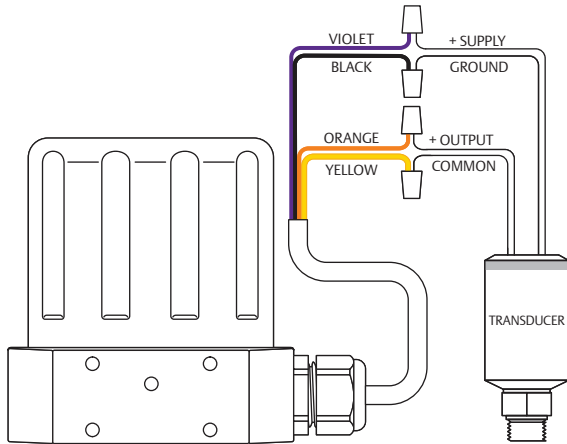

Figure 33: Four Wire Transducer Wiring

⚠ WARNING



The controller must be disconnected from the power supply before any additional wiring or change to jumper configuration is performed. Do not reconnect the power supply until all additional wiring connections have been made and are properly installed.

Refer to Table 16 to verify correct wiring.

Table 16: Wiring for Four Wire Transducer

J3 Pins	Wire Color	Function
1	brown	+setpoint input
2	red	-setpoint input
3	orange	+feedback input
4	yellow	-feedback input
5	green	-RS485 network connection
6	blue	+RS485 network connection
7	violet	+24V DC power
8	gray	24V return (power ground)
9	white	+5V output (5 mA max.)
10	black	analog signal/board ground
*11	*pink	analog signal output (active in Enhanced "F" models ONLY)
12	tan	analog signal/board ground

NOTE Check that **Jumper J6** (refer to Figure 19) is installed for 4–20 mA operation and removed for 1–5V operation. There is no jumper on the 0–10 Volt ER5000 models.



ER5000 — Installation Variations

Feedback Wiring Variations

4–20 mA External Feedback, Floating Input, Feedback Signal Monitored by PC or PLC A/D Card

Figure 34 shows how the feedback signal can be monitored using an A/D card in the PC or a PLC. The feedback signal can, alternatively, be monitored through the USB connection between the ER5000 and the PC by reading variable #44 (ID_FEEDBACK).

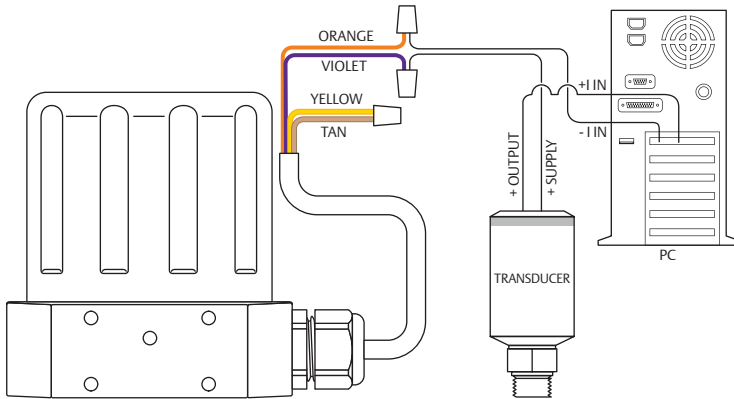

Figure 34: Monitor 4–20 mA External Feedback (Floating Input)

⚠ WARNING



The controller must be disconnected from the power supply before any additional wiring or change to jumper configuration is performed. Do not reconnect the power supply until all additional wiring connections have been made and are properly installed.

Refer to Table 17 to verify correct wiring.

Table 17: Wiring for Monitoring 4–20 mA External Feedback (Floating Input)

J3 Pins	Wire Color	Function
1	brown	+setpoint input
2	red	-setpoint input
3	orange	+feedback input
4	yellow	-feedback input
5	green	-RS485 network connection
6	blue	+RS485 network connection
7	violet	+24V DC power
8	gray	24V return (power ground)
9	white	+5V output (5 mA max.)
10	black	analog signal/board ground
*11	*pink	analog signal output (active in Enhanced "F" models ONLY)
12	tan	analog signal/board ground

NOTE Check that **Jumper J6** (refer to Figure 19) is installed for 4–20 mA operation.

ER5000 — Installation Variations

Feedback Wiring Variations

4–20 mA External Feedback, Ground Referenced Input, Feedback Signal Monitored by PC or PLC A/D Card

Figure 35 show how the feedback signal can be monitored using an A/D card in the PC or a PLC. The feedback signal can, alternatively, be monitored through the USB connection between the ER5000 and the PC by reading variable #44 (ID_FEEDBACK).

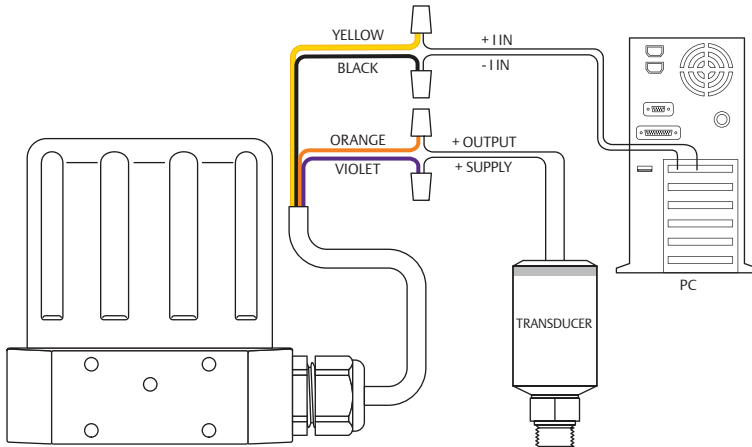

Figure 35: Monitor 4–20 mA External Feedback (Ground Referenced Input)

⚠ WARNING



The controller must be disconnected from the power supply before any additional wiring or change to jumper configuration is performed. Do not reconnect the power supply until all additional wiring connections have been made and are properly installed.

Refer to Table 18 to verify correct wiring.

Table 18: Wiring for Monitoring 4–20 mA External Feedback (Ground Referenced Input)

J3 Pins	Wire Color	Function
1	brown	+setpoint input
2	red	-setpoint input
3	orange	+feedback input
4	yellow	-feedback input
5	green	-RS485 network connection
6	blue	+RS485 network connection
7	violet	+24V DC power
8	gray	24V return (power ground)
9	white	+5V output (5 mA max.)
10	black	analog signal/board ground
*11	*pink	analog signal output (active in Enhanced "F" models ONLY)
12	tan	analog signal/board ground

NOTE The wiring shown in Figure 35 is for a two wire transducer. Refer to Figure 32 and Figure 33, respectively, for correct wiring of three wire and four wire transducers.

NOTE Check that **Jumper J6** (refer to Figure 19) is installed for 4–20 mA operation.

ER5000 — Installation Variations

Feedback Wiring Variations

Two Wire Transducer, PC or PLC A/D Card Used to Monitor Voltage Produced by the 4–20 mA External Feedback

Figure 36 shows correct wiring for applications where it is necessary to monitor the voltage produced across the ER5000's internal 250Ω resistor, rather than breaking into the 4–20 mA loop, to avoid producing ground loops.

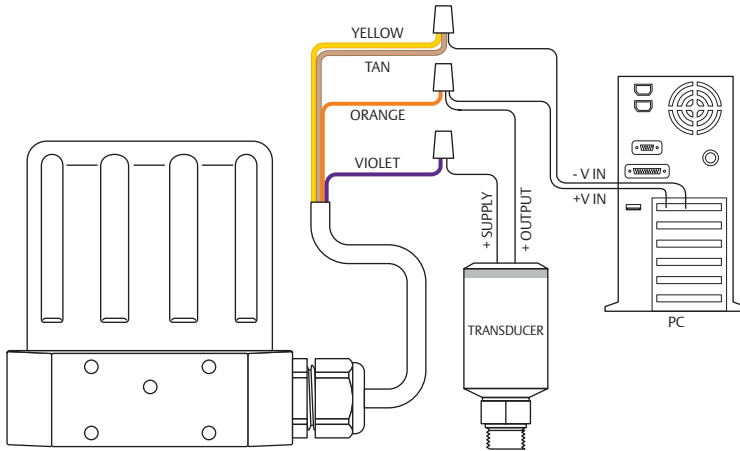

Figure 36: Two Wire Transducer, Monitor Voltage Produced by 4–20 mA Feedback

⚠ WARNING



The controller must be disconnected from the power supply before any additional wiring or change to jumper configuration is performed. Do not reconnect the power supply until all additional wiring connections have been made and are properly installed.

The feedback signal can, alternatively, be monitored through the USB connection between the ER5000 and the PC by reading variable #44 (ID_FEEDBACK).

Refer to Table 19 for correct wiring.

Table 19: Wiring for Monitoring Voltage from 4–20 mA External Feedback, Two Wire Transducer

J3 Pins	Wire Color	Function
1	brown	+setpoint input
2	red	-setpoint input
3	orange	+feedback input
4	yellow	-feedback input
5	green	-RS485 network connection
6	blue	+RS485 network connection
7	violet	+24V DC power
8	gray	24V return (power ground)
9	white	+5V output (5 mA max.)
10	black	analog signal/board ground
*11	*pink	analog signal output (active in Enhanced "F" models ONLY)
12	tan	analog signal/board ground

NOTE Check that **Jumper J6** (refer to Figure 19) is installed for 4–20 mA operation.

ER5000 — Installation Variations

Feedback Wiring Variations

Three Wire Transducer, PC or PLC A/D Card Used to Monitor Voltage Produced by the 4–20 mA External Feedback

Figure 37 shows correct wiring for applications where it is necessary to monitor the voltage produced across the ER5000's internal 250Ω resistor, rather than breaking into the 4–20 mA loop, to avoid producing ground loops.

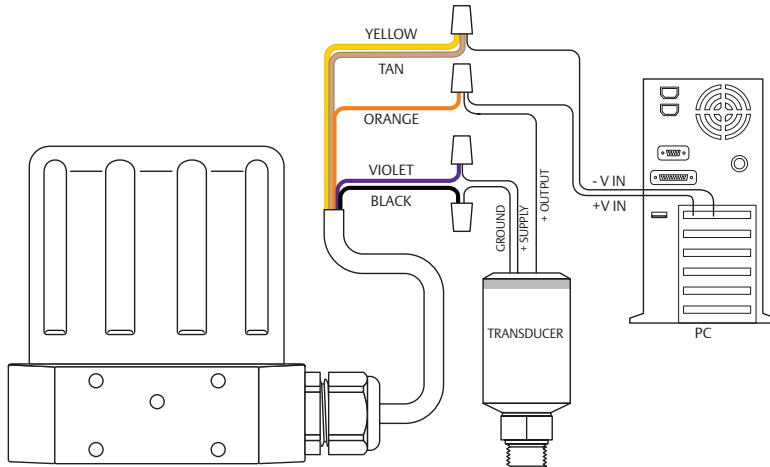

Figure 37: Three Wire Transducer, Monitor Voltage Produced by 4–20 mA Feedback

⚠ WARNING



The controller must be disconnected from the power supply before any additional wiring or change to jumper configuration is performed. Do not reconnect the power supply until all additional wiring connections have been made and are properly installed.

The feedback signal can, alternatively, be monitored through the USB connection between the ER5000 and the PC by reading variable #44 (ID_FEEDBACK).

Refer to Table 20 for correct wiring.

Table 20: Wiring for Monitoring Voltage from 4–20 mA External Feedback, Three Wire Transducer

J3 Pins	Wire Color	Function
1	brown	+setpoint input
2	red	-setpoint input
3	orange	+feedback input
4	yellow	-feedback input
5	green	-RS485 network connection
6	blue	+RS485 network connection
7	violet	+24V DC power
8	gray	24V return (power ground)
9	white	+5V output (5 mA max.)
10	black	analog signal/board ground
*11	*pink	analog signal output (active in Enhanced "F" models ONLY)
12	tan	analog signal/board ground

NOTE Check that **Jumper J6** (refer to Figure 19) is installed for 4–20 mA operation and removed for 1–5V operation. There is no jumper on the 0–10V ER5000 models.

ER5000 — Installation Variations

Feedback Wiring Variations

Four Wire Transducer, PC or PLC A/D Card Used to Monitor Voltage Produced by the 4–20 mA External Feedback

Figure 38 shows correct wiring for applications where it is necessary to monitor the voltage produced across the ER5000's internal 250Ω resistor, rather than breaking into the 4–20 mA loop, to avoid producing ground loops.

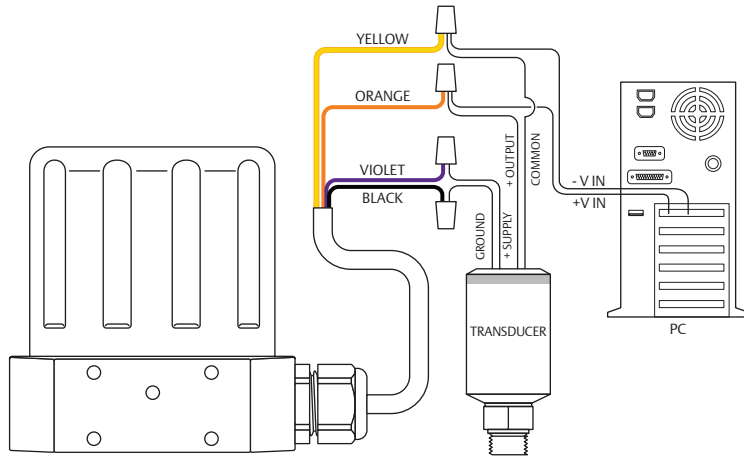

Figure 38: Four Wire Transducer, Monitor Voltage Produced by 4–20 mA Feedback

⚠ WARNING



The controller must be disconnected from the power supply before any additional wiring or change to jumper configuration is performed. Do not reconnect the power supply until all additional wiring connections have been made and are properly installed.

The feedback signal can, alternatively, be monitored through the USB connection between the ER5000 and the PC by reading variable #44 (ID_FEEDBACK).

Refer to Table 21 for correct wiring.

Table 21: Wiring for Monitoring Voltage from 4–20 mA External Feedback, Four Wire Transducer

J3 Pins	Wire Color	Function
1	brown	+setpoint input
2	red	-setpoint input
3	orange	+feedback input
4	yellow	-feedback input
5	green	-RS485 network connection
6	blue	+RS485 network connection
7	violet	+24V DC power
8	gray	24V return (power ground)
9	white	+5V output (5 mA max.)
10	black	analog signal/board ground
*11	*pink	analog signal output (active in Enhanced "F" models ONLY)
12	tan	analog signal/board ground

NOTE Check that **Jumper J6** (refer to Figure 19) is installed for 4–20 mA operation and removed for 1–5V operation. There is no jumper on the 0–10V ER5000 models.

ER5000 — Installation Variations

Feedback Wiring Variations

Switch Feedback Control to a Second Feedback Source

NOTE This feature is only available on “F” models of the ER5000. In “F” model ER5000s, the feedback source can easily be switched between two feedback sources. Refer to Table 22 for correct wiring.

Table 22: Wiring For Two Feedback Sources (Two Wire Transducer)

J3 Pins	Wire Color	Function
1	brown	+setpoint input
2	red	-setpoint input
3	orange	+feedback input
4	yellow	-feedback input
5	green	-RS485 network connection
6	blue	+RS485 network connection
7	violet	+24V DC power
8	gray	24V return (power ground)
9	white	+5V output (5 mA max.)
10	black	analog signal/board ground
*11	*pink	analog signal output (active in Enhanced “F” models ONLY)
12	tan	analog signal/board ground

J4 Pins	Wire Color	Function
1	brown/white	+aux input #1
2	red/black	-aux input #1
3	orange/black	+aux input #2
4	yellow/black	-aux input #2
5	green/white	suspend control
6	black/white	digital output/board ground
7	blue/white	digital output #1
8	gray/black	digital output #2

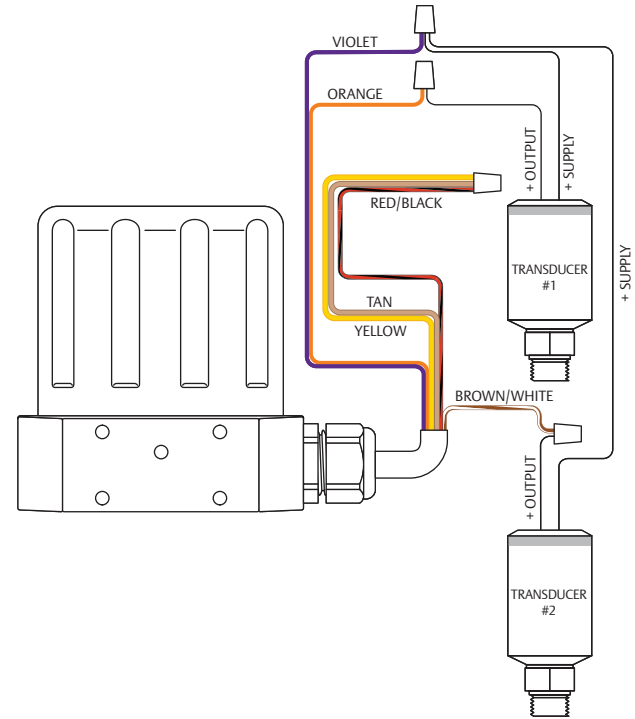



Figure 39: Switch Between Two External Feedback Sources

(continued next page)

ER5000 — Installation Variations

Switch Feedback Control to a Second Feedback Source (cont.)

WARNING

 The controller must be disconnected from the power supply before any additional wiring or change to jumper configuration is performed. Do not reconnect the power supply until all additional wiring connections have been made and are properly installed.

This feature is part of The Power User Tab and is accessed in The Additional ER Settings Panel. It allows the ER5000 to maintain optimal control over different pressure ranges.

Transducers recommended for use with the ER5000 have an accuracy of 0.1% of their full range, so transducers with a smaller range have greater accuracy within that range.

In an application where the full range is 2,000 psig / 138 bar, but where the 0–500 psig / 0–35 bar range is critical, a single 2000 psig / 138 bar transducer has an accuracy of +/- 2 psig / 0.14 bar across the entire range of the application.

Switching the feedback between a 500 psig / 35 bar transducer for the critical range and the 2000 psig / 138 bar transducer for the rest of the range, improves the accuracy within the critical range to +/- 0.5 psig / 0.03 bar.

 **NOTE** The wiring shown in Figure 39 on the previous page is for two wire transducers. Refer to Figure 32 and Figure 33, respectively, for correct wiring of three wire and four wire transducers.

Wiring Variations for Additional Functions

Monitoring Additional Analog Inputs

The ER5000 can monitor signals from a number of analog sources, as well as monitoring the state of internal variables, during normal system operation. This is useful for data acquisition to perform trend analysis on the system. The two transducers (e.g., with outputs P1 and P2) shown in Figure 39 on the previous page can be continuously monitored by a PC program such as the ERTune™ program.

All ER5000 models can monitor two analog signals: the analog setpoint and external feedback. “F” model ER5000s can monitor two additional analog signals: the Auxiliary Input #1 and Auxiliary Input #2.

 **NOTE** Auxiliary Input #2 doubles as the Profile Start/Stop input. If you are monitoring this input, you should change its toggle level from the default value of 2050 to the maximum value of 4095. This will prevent the Profile from running. The toggle level is set by adjusting variable #86 (ID_AD_EXTRA2_TOGGLE). Refer to Internal Variables for more information.

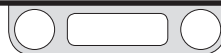

ER5000 — Installation Variations

Wiring Variations for Additional Functions

Monitoring the ER5000's Internal Sensor Using the Analog Output, 4–20 mA Wiring

NOTE This feature is only available on “F” models of the ER5000.

The ER5000 provides the capability of monitoring the internal sensor through direct wiring to the PC. The internal sensor can, alternatively, be monitored through the USB or RS485 connection between the ER5000 and the PC by reading variable #6 (ID_COMPENSATED_INTERNAL_SENSOR).

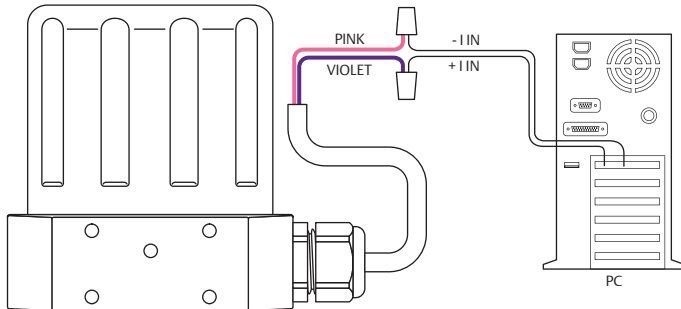

Figure 40: Monitor Internal Sensor (4–20 mA Wiring)

⚠ WARNING



The controller must be disconnected from the power supply before any additional wiring or change to jumper configuration is performed. Do not reconnect the power supply until all additional wiring connections have been made and are properly installed.

Refer to Table 23 to verify correct wiring.

Table 23: Wiring for Monitoring Internal Sensor (4–20 mA)

J3 Pins	Wire Color	Function
1	brown	+setpoint input
2	red	-setpoint input
3	orange	+feedback input
4	yellow	-feedback input
5	green	-RS485 network connection
6	blue	+RS485 network connection
7	violet	+24V DC power
8	gray	24V return (power ground)
9	white	+5V output (5 mA max.)
10	black	analog signal/board ground
*11	*pink	analog signal output (active in Enhanced “F” models ONLY)
12	tan	analog signal/board ground



ER5000 — Installation Variations

Wiring Variations for Additional Functions

Monitoring the ER5000's Internal Sensor Using the Analog Output, 0–10V Wiring

NOTE This feature is only available on “F” models of the ER5000.

The ER5000 provides the capability of monitoring the internal sensor through direct wiring to the PC. The internal sensor can, alternatively, be monitored through the USB or RS485 connection between the ER5000 and the PC by reading variable #6 (ID_COMPENSATED_INTERNAL_SENSOR).

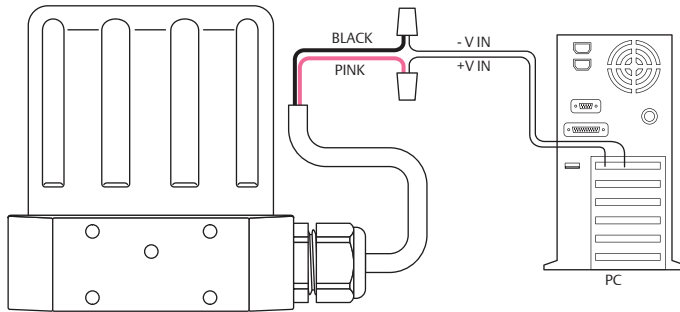

Figure 41: Monitor Internal Sensor (0–10V Wiring)

⚠ WARNING



The controller must be disconnected from the power supply before any additional wiring or change to jumper configuration is performed. Do not reconnect the power supply until all additional wiring connections have been made and are properly installed.

Refer to Table 24 to verify correct wiring.

Table 24: Wiring for Monitoring Internal Sensor (0–10V)

J3 Pins	Wire Color	Function
1	brown	+setpoint input
2	red	-setpoint input
3	orange	+feedback input
4	yellow	-feedback input
5	green	-RS485 network connection
6	blue	+RS485 network connection
7	violet	+24V DC power
8	gray	24V return (power ground)
9	white	+5V output (5 mA max.)
10	black	analog signal/board ground
*11	*pink	analog signal output (active in Enhanced “F” models ONLY)
12	tan	analog signal/board ground



ER5000 — Installation Variations

Wiring Variations for Additional Functions

Digital Outputs

NOTE This feature is only available on “F” models of the ER5000.

The ER5000 can provide digital outputs to the rest of the system. Refer to Table 25 for correct wiring.

Table 25: Wiring for Digital Outputs

J3 Pins	Wire Color	Function
1	brown	+setpoint input
2	red	-setpoint input
3	orange	+feedback input
4	yellow	-feedback input
5	green	-RS485 network connection
6	blue	+RS485 network connection
7	violet	+24V DC power
8	gray	24V return (power ground)
9	white	+5V output (5 mA max.)
10	black	analog signal/board ground
*11	*pink	analog signal output (active in Enhanced “F” models ONLY)
12	tan	analog signal/board ground

J4 Pins	Wire Color	Function
1	brown/white	+aux input #1
2	red/black	-aux input #1
3	orange/black	+aux input #2
4	yellow/black	-aux input #2
5	green/white	suspend control
6	black/white	digital output/board ground
7	blue/white	digital output #1
8	gray/black	digital output #2

(continued next page)

⚠ WARNING



The controller must be disconnected from the power supply before any additional wiring or change to jumper configuration is performed. Do not reconnect the power supply until all additional wiring connections have been made and are properly installed.

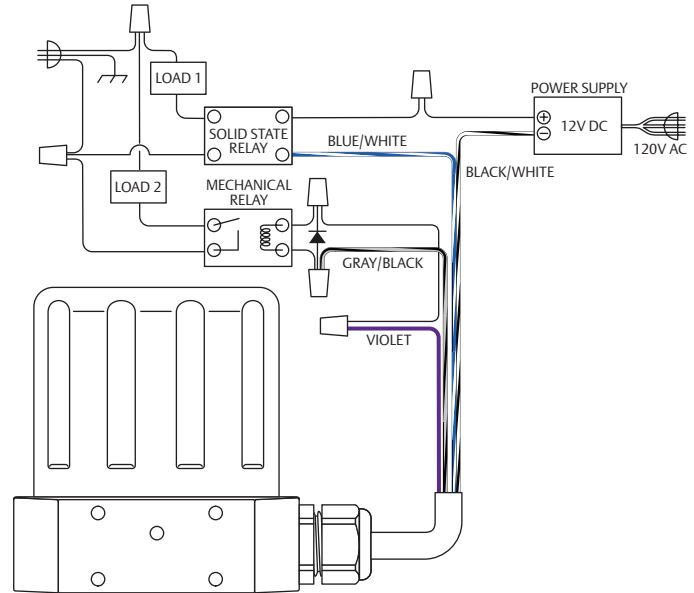

Figure 42: ER5000 Digital Outputs

ER5000 — Installation Variations

Digital Outputs (cont.)

The outputs can be toggled using a PC computer program or as part of a Profile and can be used to trigger a process in another part of the system, such as to turn on an audio or visual alarm or to start a conveyor belt.

As shown in Figure 42:

- Output #1 uses an external power supply to switch a 12V DC solid state relay, which controls Load 1.
- Output #2 uses the ER5000's power supply to switch a 24V DC relay, which controls Load 2.

NOTE Digital Output #1 and Digital Output #2 are Open Collector circuits. Refer to the Glossary of Terms section for more information.

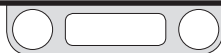

ER5000 — Installation Variations

Wiring Variations for Additional Functions

Suspend Mode

NOTE This feature is only available on “F” models of the ER5000.

Suspend Mode is a new feature for “F” model ER5000s. When Suspend Mode is activated, the Inlet and Exhaust valves remain fully closed and the PID algorithm is suspended. This ensures a completely stable state, with no unwanted response to system noise, until Suspend Mode is deactivated. This feature is useful for applications, such as calibrating a sensor or detecting a leak, where total stability is required.

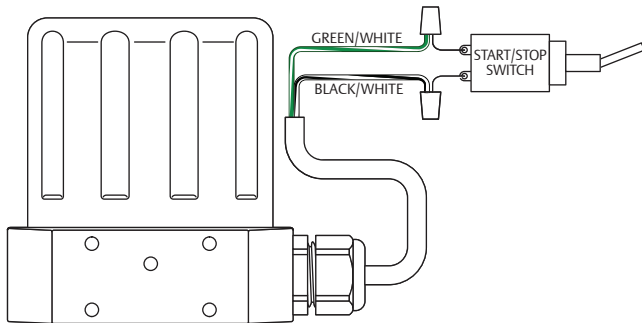

Figure 43: Suspend Mode

⚠ WARNING



The controller must be disconnected from the power supply before any additional wiring or change to jumper configuration is performed. Do not reconnect the power supply until all additional wiring connections have been made and are properly installed.

Refer to Table 26 for correct wiring.

Table 26: Wiring for Suspend Mode

J3 Pins	Wire Color	Function
1	brown	+setpoint input
2	red	-setpoint input
3	orange	+feedback input
4	yellow	-feedback input
5	green	-RS485 network connection
6	blue	+RS485 network connection
7	violet	+24V DC power
8	gray	24V return (power ground)
9	white	+5V output (5 mA max.)
10	black	analog signal/board ground
*11	*pink	analog signal output (active in Enhanced “F” models ONLY)
12	tan	analog signal/board ground

J4 Pins	Wire Color	Function
1	brown/white	+aux input #1
2	red/black	-aux input #1
3	orange/black	+aux input #2
4	yellow/black	-aux input #2
5	green/white	suspend control
6	black/white	digital output/board ground
7	blue/white	digital output #1
8	gray/black	digital output #2

ER5000 — Installation Variations

Installing a Hazardous Location Model (ER5050)

⚠ WARNING

- ⚠ Install conduit rated for your Hazardous Location using local and national electrical codes which apply to the application.
- ⚠ Conduit must be sealed within 18" of conduit's point of entry into the ER5050.
- ⚠ Make sure everything is properly assembled before powering.
- ⚠ DO NOT open cover when an explosive atmosphere is present.
- ⚠ The cable and conduit entry devices shall be certified flame proof types, suitable for the conditions of use and correctly installed.
- ⚠ Unused conduit entry must be closed with suitable blanking element.



Click this link to view all Hazardous Location certifications and specifications.

Figure 44: Typical Hazardous Location ER5050 Application
Controller, with adaptor, is mounted to an air actuated regulator. Feedback is from the external transducer. All wiring run through junction box that meets Hazardous Location specification. Setpoint is from a Profile downloaded from the PC.

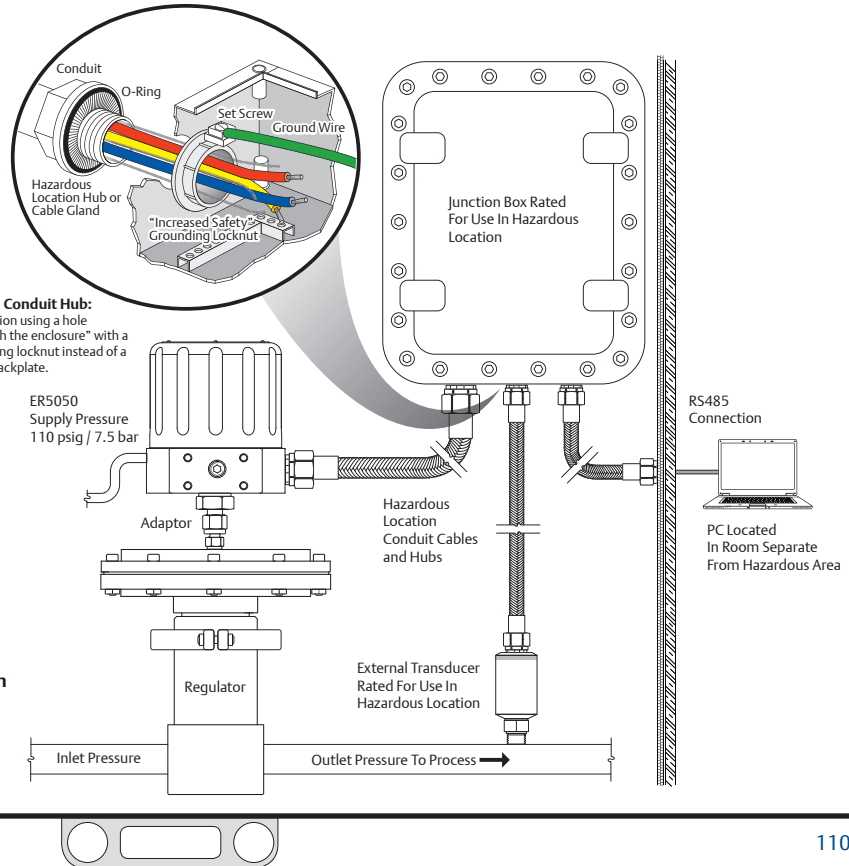



THE ERTUNE™ PROGRAM



ER5000 — The ERTune™ Program

Navigating the Screen: Tabs, Panels, Windows and Fields

The ERTune™ Program: Basic Features 116

Where to Find the ERTune™ Program
Files on Your PC. 117

Installing the ERTune™ Program 118

The ERTune™ Program User Interface 126

Navigating the ERTune™ User Interface 127

- The Menu Bar 127
 - The File Menu 127
 - Save Configuration 127
 - Change Configuration 127
 - Exit 127
 - The Node Menu 127
 - Node Select 127
 - Search Node 128
 - The Help Menu 128
 - Power User 128
 - User Manual 128
 - About 128

The Tab Area 129

The Plot Screen 130

- Resizing the Range Displayed by the Plot Screen Using the Mouse 132
- The Plot Screen Menu Bar 134

- The Plot Screen Menu —
 - The Main Axis Menu 134
 - Time 134
 - Minimum Vertical 134
 - Maximum Vertical 134
 - Rescale Vertical 134
 - The Plot Screen Menu —
 - The Secondary Axis Menu 134
 - Minimum Vertical 135
 - Maximum Vertical 135
 - Rescale Vertical 135
 - The Plot Screen Buttons —
 - The Start Plot/Stop Plot Button 135
 - The Plot Screen Buttons — The Print Button 135

The Plot Screen Variable Controls 137

The Footer Area. 142

The Tuning Tab: Controls and Functions for Tuning the ER5000 143

- Tuning the ER5000 144
 - Before You Begin 144
- The Setpoint Panel 145
 - Selecting a Setpoint Source 145
 - Analog Input Setpoint Source 145
 - ERTune Program 145
 - Profile 145
 - External Device Setpoint Source 145
 - Toggle Mode Setpoint Source 145
 - Ramp Mode Setpoint Source 146
 - Profile Setpoint Source 147

- The PID Control Panel 148
 - The Proportional Controller 149
 - Proportional Tuning Tips 149
 - The Derivative Controller 150
 - Derivative Tuning Tips 150
 - The Integral Controller 150
 - Integral Tuning Tips 150
 - The Integral Limits Controllers 151
 - Maximum 151
 - Minimum 151
 - Deadband 151

A Typical Step Tuning Example 152

The Initial Settings 152

Cascade Tuning. 159

Cascade Tuning Tips 159

The Profile Tab: Creating Multi-Step Command Sequences 160

- The Panels and Windows of the Profile Tab 161
- The Profile Panel 162
 - The Profile Window 162
 - Print 162
 - Upload 162
 - Download 162
 - Open 162
 - Save 162
- The Profile Builder Panel 163
 - The Segment Types Window 163
 - The Segment Editor Window 163
 - Insert 163



ER5000 — The ERTune™ Program

Modify	163	The Configure Tab	178	The ERTune™ Program:	
Delete	163	The Mechanical Regulator Panel	179	Power User	187
The Commands in the Profile Builder	165	The ER Settings Panel	179	The Power User Tab	188
Step	165	ER Model #	179	The Additional ER Settings Panel	189
Ramp	165	Control Mode	179	External Feedback Source	189
Dwell	165	ER Node	180	Setpoint to 0 on Power Up	189
Loop	165	Calibration	180	The Read/Write Panel	190
Delta	166	The Control Limits Panel	181	The Solenoid Settings Panel	191
Change Variable	166	The Diaphragm Protection Panel	183	Minimum Pulse Width	191
Additional Commands Available		The Diagnostic Tools Tab	184	Normal/Reverse	191
for “F” Model ER5000s	167	The System Check Panel	184	The Algorithm Update Rate Panel	192
Soak	167	The ER Solenoid Leak Test Panel	184	The Pulse Mode Panel	193
If	167	The Regulator Leak Check Panel	186	Period	193
Goto	168	The Tuning Tips Panel	186	Width	193
Digital Output				Deadband	194
(ER Outputs are Ports 3 & 4)	169			The Power User Tab: The Password Panel	195
Digital Input (ER Input is Port 3)	169				
The Data Tab	170				
The Acquisition Panel	172				
The Output Panel	173				
Output File	173				
Browse Button	173				
Delimiter	173				
DAQ Comment Block	173				
Plot File Button	173				
Start DAQ Button	173				
Collecting and Reviewing Data	174				
The Triggers Panel	176				



ER5000 — The ERTune™ Program

Using The Program: Tasks, Features and Functions

The ERTune™ Program: Basic Features

116

Where to Find the ERTune™ Program Files on Your PC

117

Installing the ERTune™ Program

118

To install the ERTune™ program	118
To install the ER5000 device driver	119
To install the ER5000 device driver manually	119
To open the ERTune™ program	119
To set up the ERTune™ program to work with the ER5000	120
To activate Regulator Diaphragm Protection	124
If the ERTune™ program does not open	125
To open the ERTune™ program without a controller connected	125
To uninstall the ERTune™ program	125

The ERTune™ Program User Interface

126

Navigating the ERTune™ User Interface

127

To switch between controllers based on Node Address	127
To select a controller from the list of active nodes	128
To display the Power User Tab	128

The Tab Area

129

To display the Power User Tab	129
-------------------------------	-----

The Plot Screen

130

To toggle the display range of the vertical axis	132
To zoom the vertical axis display	132
To return the vertical axis display to the default setting	132
To zoom the display of both the vertical and horizontal axes	133
To return both axes to the default display settings	133
To change the horizontal axis using the Main Axis Menu	136
To change the main (left) vertical axis using the Main Axis Menu	136
To reset the main (left) vertical axis to its original values using the Main Axis Menu	136

The Plot Screen Variable Controls

137

To track an additional variable	138
To add a variable to the Plot Screen display	138
To set or change the range for an added variable	138
To optimize the display when both additional variables have been added to the Plot Screen	139
To change which variable is being tracked	140
To remove a variable from the Plot Screen display	140
To stop tracking a variable	140
To change the secondary axis using the Secondary Axis Menu	140

To reset the secondary axis to its original values using the Secondary Axis Menu	140
To change the range of feedback values tracked by the ERTune™ program	141
To change the display of the main (left) axis to the new range	141

The Footer Area

142

The Tuning Tab: Controls and Functions for Tuning the ER5000

143

To select a setpoint source	145
To set the two setpoint values	145
To change a setpoint value during tuning	146
To toggle setpoint using the Tuning Tab	146
To toggle setpoint using the Space Bar	146
To set the target value of a ramp change	146
To set the rate of a ramp change	146
To initiate a ramp change	146
To tune the ER5000 using a Profile	147
To pause the Profile	147
To resume running the Profile	147
To reset the ER5000 to its default PID settings	149

A Typical Step Tuning Example

152

To activate the Plot Screen	152
To toggle the setpoint	152
To set the Proportional Term	153
To add the Derivative Term	154



ER5000 — The ERTune™ Program

To add the Integral Term	156
To limit the effect of the Integral Term using the Integral Limits	156
To add Integral Deadband	158
Cascade Tuning	159
The Profile Tab: Creating Multi-Step Command Sequences	160
To add a command line (segment) to a Profile	164
To modify a segment in a Profile	164
To delete a segment from a Profile	164
To add comments to a Profile	164
To use a Profile to control the ER5000	164
The Data Tab	170
To add a variable using the Plot Screen Variable Controls	171
To set or change the range for an added variable	171
To add a variable using the Power User Tab	171
To control data collection manually	172
To start data collection	174
To stop data collection	174
To view an acquired data file	175
To collect data based on a triggered event	176
To activate data collection based on a triggered event	176
To deactivate data collection based on a triggered event	177
To remove a triggered event from data collection	177

The Configure Tab	178
To change the Regulator Series	179
To change the regulator model number or serial number	179
To change the Control Mode of the ER5000	179
To change the Node Address of the ER5000	180
To change the calibration of the ER5000	180
To add a Control Limit for the ER5000 to monitor	182
To remove a Control Limit	182
To remove all Control Limits	182
To change the Control Limit Condition	182
To activate Regulator Diaphragm Protection	183
To deactivate Regulator Diaphragm Protection	183
The Diagnostic Tools Tab	184
To perform a solenoid valve leak test	184

The ERTune™ Program: Power User	187
The Power User Tab	188
To display the Power User Tab	188
To switch the external feedback source	189
To enable Setpoint to 0 on Power Up	189
To check the value of an Internal Variable	190
To modify the value of an Internal Variable	190
To add a variable to data acquisition	190
To remove a variable from data acquisition	190
To change the Algorithm Update Rate	192
To enable Pulse Mode	193
To disable Pulse Mode	193
To change the Pulse Width settings	194
If you forget your password	195
To enable password protection	195
To disable password protection	195
To change the current password	195





THE ERTUNE™ PROGRAM: BASIC FEATURES



ER5000 — The ERTune™ Program: Basic Features

Where to Find the ERTune™ Program Files on Your PC

The ERTune™ program creates two folders on your C: drive during installation.

On PCs running Windows 7, the program files, including the program executables, device drivers, support files and reference materials, are located at:

C: -> Program Files (x86) -> Emerson -> ERTune.

On PCs running previous versions of Windows, this is located at:

C: -> Program Files -> Emerson -> ERTune.

A separate folder is created for data files generated by the program. On PCs running Windows 7, this is located at:

C: -> Program Data -> Emerson -> ERTune.

On PCs running previous versions of Windows, this is located at:

C: -> Documents and Settings -> All Users -> Application Data -> Emerson -> ERTune.

This folder is the default location for configuration files, Profiles and data acquisition files. The Windows Navigator window will default to this folder. You may save the data files generated by your application in another location, if you prefer.

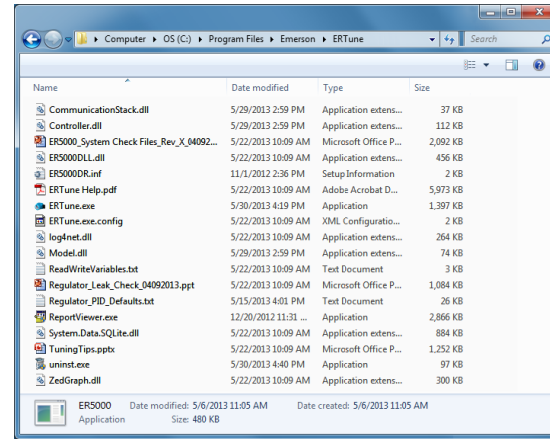

ER5000 — The ERTune™ Program: Basic Features

Installing the ERTune™ Program

The ERTune™ program provides an intuitive interface to customize the performance of the ER5000 to meet the specific requirements of your application. Using the controls and features of the program, you can:

- Manually tune the PID parameters to optimize the response of the ER5000.
- Create and download Profiles that guide the ER5000 through multi-segment sequences of commands.
- Track, save and review data acquired during tuning sessions and normal system operation.
- Configure basic operating parameters and set up the ER5000 to monitor and respond to system Control Limits.
- Perform basic troubleshooting.

NOTE The ERTune™ program is available in English, German and Chinese versions. When installation begins, the installer checks the default language settings for the computer and if German or Chinese are detected, the corresponding translated version is installed. Otherwise, the English version is installed.

To install the ERTune™ program

1. Download the ER5000 Software and Manual file which can be found at TESCOM.com under the “Download ER5000 Software and Manual” link. Once the file is downloaded, extract the zip file, click on the .exe file, and the ER5000 User Support Software and Manual menu will open.
2. The ER5000 User Support Software and Manual menu gives you access to the programs and reference materials. Click the Install ERTune button.
3. Follow the steps in the ERTune Setup Wizard. When Installation is complete, click Close.



ER5000 — The ERTune™ Program: Basic Features

The ER5000 device driver

The ER5000DR device driver must be installed in your computer to allow for direct USB connection between the controller and the computer.

To install the ER5000 device driver manually

Some operating system configurations require that device drivers be installed manually. If the ER5000DR driver does not install automatically, refer to the [Troubleshooting](#) section.

To open the ERTune™ program

IMPORTANT! The ER5000 controller must be powered up and connected to the computer for the ERTune™ program to open.

If the program does not open and instead you see the Comm Error window, refer to [If the ERTune™ program does not open](#).

1. Click the ERTune icon in your START menu.

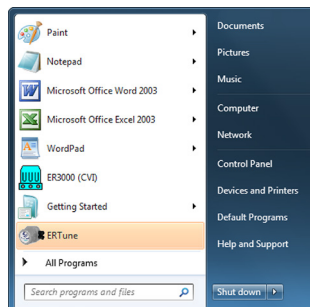

OR

Select Start -> All Programs -> ERTune -> ERTune. Click the menu item to open the program.

2. The ERTune™ Welcome screen opens.

(continued next page)



ER5000 — The ERTune™ Program: Basic Features

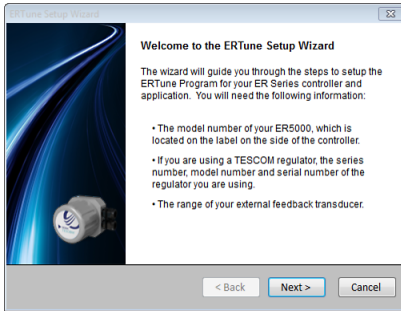

If this is the first time the ER5000 has been connected to the computer, you will be taken through the steps to set up the ERTune™ program for your controller and application. The program runs the setup sequence every time it communicates with an ER5000 that has a new serial number.

To set up the ERTune™ program to work with the ER5000

NOTE Be sure you have the following information in hand:

- The model number of your ER5000, which is located on the label on the side of the controller.
- If you are using a TESCOM™ regulator, the series number, model number and serial number of the regulator you are using.
- The range of your external feedback transducer.

1. Click the Next > button. The Node and Model window opens.

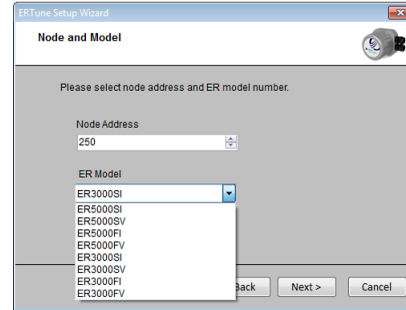

2. The Node Address is set to a default of 250. If you are using multiple controllers in a daisychain on the same network, you must assign each controller a unique Node Address during this step. If you are using a single controller, there is no need to change the default value.

NOTE The maximum value for the Node Address is the default of 250. If you assign a different Node Address, use a number that is less than 250. Numbers larger than 250 will be truncated to the first two digits.

(continued next page)

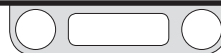

ER5000 — The ERTune™ Program: Basic Features

- In the ER Model drop-down list, select the ER model number that matches the model number of your controller.

NOTE All ER5000 model numbers have a “-1” extension. This extension has been truncated from the model numbers displayed in the list.

- Click the Next > button. The Control Mode window opens.

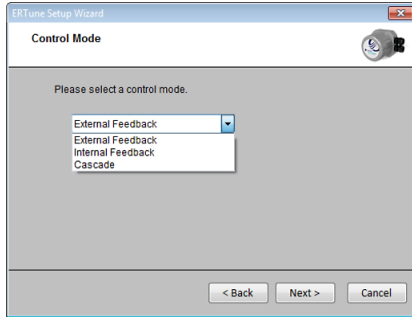

- The Setup Wizard reads and displays the current Control Mode for your controller. External Feedback is default for new controllers. The other options are Internal Feedback and Cascade.

- Select the Control Mode that is appropriate for your application and click the Next > button. The Sensor Range window opens.

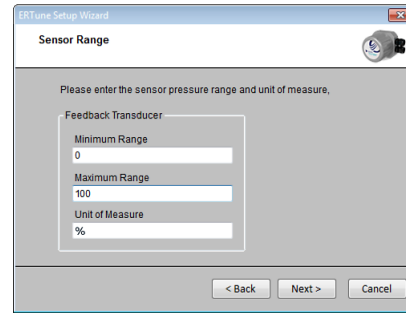

The fields in this window set the default range and the unit of measurement for the Plot Screen in the ERTune™ program. The default is percentage; you can change this to psig or bar or some other unit of measurement.

CAUTION

If you change the unit of measurement from percentage, be sure your Min and Max values accurately represent the specifications for your feedback source.

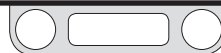

ER5000 — The ERTune™ Program: Basic Features

7. The label you see for the field set in this window depends on the Control Mode you selected in Step 6.

- If you selected **External Feedback** control mode, the range is labeled Feedback Transducer. Enter the range listed in the specifications for the external transducer you will be using for your application.
- If you selected **Internal Feedback** control mode, the range is labeled Internal Feedback. Enter the 0–100 psig / 0–6.9 bar range for the ER5000's internal sensor.
- If you selected **Cascade** control mode, the range is labeled Feedback Transducer. Enter the range listed in the specifications for the external transducer you will be using for your application.

NOTE As a general rule, the Internal Feedback range should be left at default for Cascade Control Mode, so only the External Feedback range is shown in this window.

8. Click the Next > button. The Mechanical Regulator Information window opens.

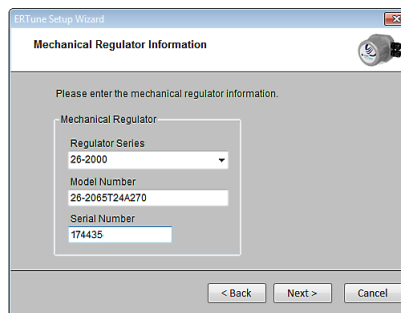

The screenshot shows a dialog box titled "Mechanical Regulator Information" from the "ERTune Setup Wizard". The dialog contains the instruction "Please enter the mechanical regulator information." and a form with the following fields:

- Regulator Series:** A drop-down menu with "26-2000" selected.
- Model Number:** A text box containing "26-2065T24A270".
- Serial Number:** A text box containing "174435".

At the bottom of the dialog are three buttons: "< Back", "Next >", and "Cancel".

9. Enter the information for the regulator you are using.

- If you are using a TESCOM™ regulator, look for its series number in the Mechanical Regulator Series drop-down list. Also enter the Model Number and Serial Number from the regulator.
- If you are using a regulator from another manufacturer, select Other. Also enter the Model Number and Serial Number from the regulator.
- If the ER5000 will not be connected to a regulator, select None.

(continued next page)



ER5000 — The ERTune™ Program: Basic Features

10. Click the Next > button. The PID Download window opens.

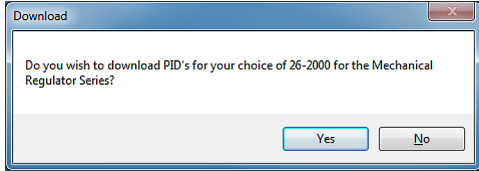

The ER5000 software includes PIDs specifically tuned for most TESCOM™ regulators, as well as default PIDs that are used if Other or None has been selected.

- 11. Click the Yes button to download the PID settings tuned for the regulator or the No button to use the factory settings.
- 12. The ERTune™ program opens.

IMPORTANT! If the regulator you selected in Step 9 is a diaphragm sensed regulator, the Regulator Diaphragm Protection window opens. You can configure the ER5000 for diaphragm protection.

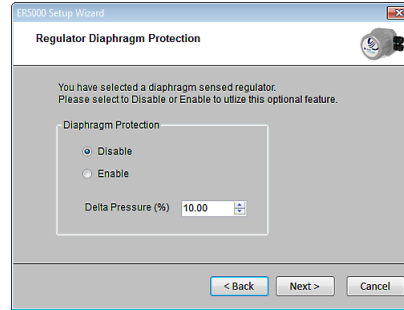

Non-venting regulators, which do not feature a regulator vent to exhaust excess system pressure, pose a particular challenge in closed loop applications when the downstream flow is blocked.

Regulator Diaphragm Protection is designed for applications that use a non-venting regulator in a system that does not have continuous flow. It is most beneficial for this type of application when the regulator is a metal diaphragm sensed regulator. For more information on this feature, refer to *A Note Concerning Non-Venting Regulators in Closed Loop Applications*.

(continued next page)

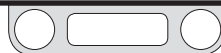

ER5000 — The ERTune™ Program: Basic Features

You should consider using this feature if your application meets **one or both** of these conditions:

- The regulator you will be using is a non-venting, metal diaphragm sensed regulator.
- The regulator you will be using is non-venting and the application is not continuous flow.

To activate Regulator Diaphragm Protection

1. Click the Enable radio button.
2. Enter a value in the Delta Pressure (%) entry field.

The value you enter in the Delta Pressure (%) entry field sets the maximum difference between the setpoint and the dome pressure of the regulator to which the ER5000 will respond, expressed as a percentage of the Sensor Range you set in Step 7.

When Delta Pressure exceeds the value entered in this field, the ER5000 stops responding to error. This prevents the high differential pressure situations and delayed response described in A Note Concerning Non-Venting Regulators in Closed Loop Applications.

3. Click the Finish Button. The ERTune™ program opens.

CAUTION

Regulator Diaphragm Protection is not recommended for applications which do not meet one or both of these conditions.

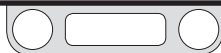

ER5000 — The ERTune™ Program: Basic Features

If the ERTune™ program does not open

1. The Comm Error window opens.

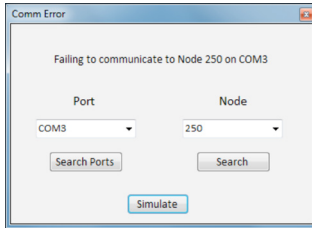

2. Click the Search Ports button. The ERTune™ program scans all COM ports that are in use.
3. If the program does not open, check that the ER5000 is powered up and connected. Refer to the [Troubleshooting](#) section for further steps.

NOTE The Comm Error window may appear briefly when the ERTune™ program opens during normal operation. Allow 10-20 seconds before taking troubleshooting action.

To open the ERTune™ program without a controller connected

1. Select Start -> All Programs -> ERTune -> ERTune Simulator.
2. Click the menu item. The ERTune™ program opens in Simulation Mode.

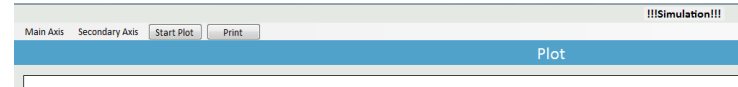

Figure 45: The Simulation Warning Above The Plot Screen

IMPORTANT! When the ERTune™ program is operating in Simulation mode, the right side of The Plot Screen Menu Bar displays a “!!!Simulation!!!” warning. Configuration changes you make while in Simulation mode have no effect on the controller.

Simulation Mode allows you to interact with all the screens and controls of the ERTune™ program. You can build and save Profiles which can be saved to the PC for later use. You can also access the reference files from [The Diagnostic Tools Tab](#); the Solenoid Leak Test, however, is not functional.

To uninstall the ERTune™ program

1. Select Start -> All Programs -> ERTune -> Uninstall ERTune.
2. Follow the steps in the Uninstall Wizard.

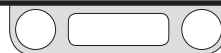

ER5000 — The ERTune™ Program: Basic Features

The ERTune™ Program User Interface

Click a heading to learn more about the features and functions of that area of the interface

The screenshot displays the ERTune software interface. The window title is "ERTune". The menu bar includes "File", "Node", and "Help". Below the menu bar are tabs for "Tuning", "Profile", "Data", "Configure", and "Diagnostic Tools".

The Menu Bar callout points to the menu bar area.

The Tab Area callout points to the "Setpoint" and "External PID" sections. The "Setpoint" section includes a dropdown for "Setpoint Source" (ERTune Program), radio buttons for "Type" (Toggle, Ramp), and input fields for "Setpoint 1" (25.00) and "Setpoint 2" (75.00). The "External PID" section includes a "Set Defaults" button and sliders for "Proportional" (1200), "Derivative" (120), "Integral" (300), "Integral Limits" (Maximum: 32, Minimum: -5), and "Deadband" (0.00).

The Plot Screen callout points to the main plot area. The plot shows a grid with the y-axis labeled "%" (0 to 100) and the x-axis labeled "Time (Sec)" (0 to 10). The text "The Plot Screen" is overlaid on the plot.

The Footer Area callout points to the bottom status bar. The footer contains the following information: ER5000SI, ER Serial #: 1018, ER Node #: 250, 26-2065T24A270, and 174435.

The Plot Screen Variable Controls callout points to the bottom right of the plot area. It includes a table of variables:

Plot	Variable Name	Value	Legend
<input checked="" type="checkbox"/>	Setpoint (37)	0.00 %	Red
<input checked="" type="checkbox"/>	Feedback (44)	0.00 %	Blue

Buttons for "Add Variable" and "Range" are also visible.



ER5000 — The ERTune™ Program: Basic Features

Navigating the ERTune™ User Interface

The Menu Bar

The menu bar displays three menu items on the left.

NOTE If the ER5000 does not detect a feedback signal, a warning will display on the right side of the menu bar.



The File Menu

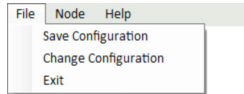

The File menu has three commands.

Save Configuration

This command saves the current tuning configuration to a text file. The file can be saved anywhere on your computer or network and uses the .tun file extension.

Change Configuration

This command loads a saved configuration (.tun) file into the ERTune™ program and downloads the tuning configuration to the ER5000.

Exit

This command exits the program.

The Node Menu

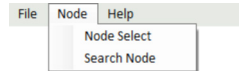

The Node menu has two commands.

Node Select

This command opens the Select Node window, which allows you to select between ER5000s when you have multiple controllers in the same network.

To switch between controllers based on Node Address

1. Select Node -> Node Select. The Select Node window opens.

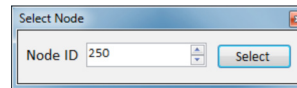

2. Enter the Node Address of the controller you wish to access.

NOTE Individual controllers connected via USB should be at the default Node Address of 250, unless this was changed during setup. If you have multiple controllers in an RS485 network and are not sure of the Node Address for each controller, refer to the Search Node command on the next page.

3. Click Select. The ERTune™ program begins communicating with the controller at that Node Address and displays the controller's configuration information.

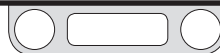

ER5000 — The ERTune™ Program: Basic Features

Search Node

This command opens the Search Nodes window. The ERTune™ program searches through all 250 Node Addresses and generates a list of active nodes.

To select a controller from the list of active nodes

1. Select Node -> Search Node. The Search Nodes window opens.

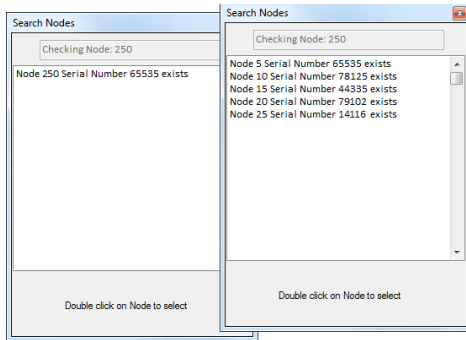
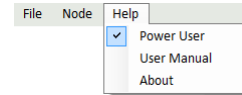

Figure 46:
Search Nodes windows for single controller and for multiple controllers in an RS485 network.

2. The ERTune™ program searches all Node Addresses and returns a list of all Addresses that are active.
3. Double-click a Node Address from the generated list to select it. The ERTune™ program will begin communicating with the controller at that Node Address and will display its configuration information.

The Help Menu



The Help Menu has three commands.

Power User

This command toggles the display of The Power User Tab on and off. The Power User Tab gives you access to advanced configuration options. Most applications of the ER5000 do not require access to this tab.

To display the Power User Tab

1. Select Help -> Power User. The Power User Tab appears to the right of the Diagnostic Tools Tab.
2. Click the Power Users Tab to make it active.

User Manual

This command opens the onscreen version of the User Manual.

About

This command opens the About ERTune™ window, which displays the version number for the software.

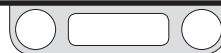

ER5000 — The ERTune™ Program: Basic Features

The Tab Area

The five tabs on the left of the screen organize the controls and entry fields of the ERTune™ program.

A brief explanation of each tab is given below. Click the tab title for detailed information on the features and function of the tab.

NOTE The Power User Tab, which gives you access to advanced configuration functions that are not required by most applications, is not displayed by default. You access it through a command in the Help menu.

The Tuning Tab

This tab displays the controls for choosing the setpoint source and for tuning the PID parameters for the ER5000.

The Profile Tab

This tab displays the controls for creating, editing, saving and opening Profiles. Profiles are multi-step command sequences for the ER5000.

The Data Tab

This tab displays the controls for collecting, exporting and retrieving data generated during tuning or operation of the ER5000, using text files with the .dat file extension which can be stored on your computer or network.

The Configure Tab

This tab displays the controls for setting and changing basic configuration options for the ER5000, including regulator information, control mode, calibration, control limits and diaphragm protection.

The Diagnostic Tools Tab

This tab gives you access to the automated Solenoid Valve Leak Test and reference materials to help you optimize performance and troubleshoot your system.

The Power User Tab

This tab displays the controls for setting and changing advanced configuration options for the ER5000. It is not displayed by default.

To display the Power User Tab

1. Select Help -> Power User. The Power User Tab appears to the right of the Diagnostic Tools Tab.
2. Click the Power Users Tab to make it active.

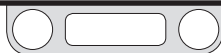

ER5000 — The ERTune™ Program: Basic Features

The Plot Screen

The Plot Screen gives you a precise visual display of the moment-by-moment interaction between setpoint changes and the ER5000's response. Watching changes to PID parameters play out in real time makes tuning a more intuitive process.

The main (left) vertical axis of the Plot Screen defaults to the feedback range you set during Step 7 of the Setup Process.

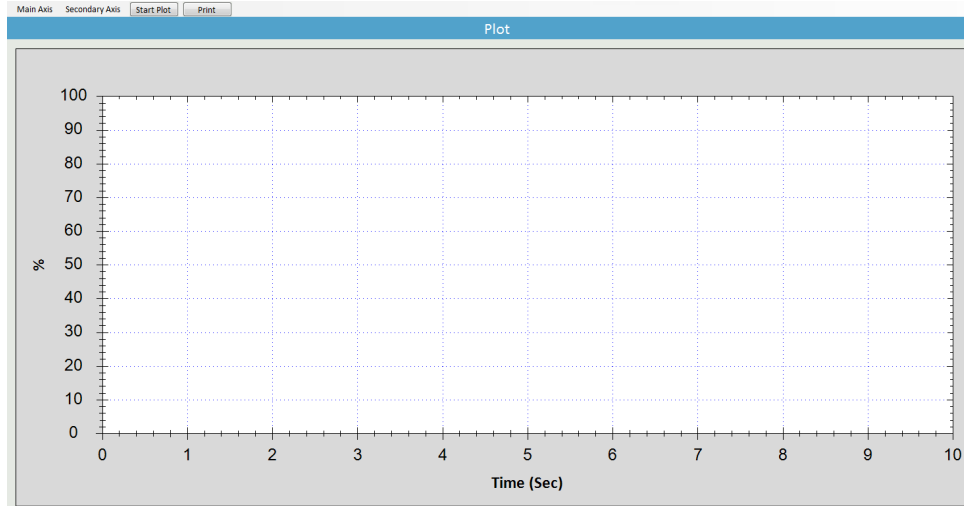

Figure 47: The Plot Screen

If you add additional variables to the display using The Plot Screen Variable Controls, a secondary (right) vertical axis appears on the right side of the Plot Screen to track these values.

The horizontal axis defaults to a cycle of 10 seconds.

You can change the cycle time and the range of values shown in the Plot Screen displays using commands in The Plot Screen Menu Bar or by interacting directly with the Plot Screen using your mouse.

You can change the actual range of values tracked by the ERTune™ program by changing the range of the Feedback (44) variable in The Plot Screen Variable Controls. Refer to page 141.

NOTE The Plot Screen has two distinct areas: the active area, which is the space within the horizontal and vertical axes and the margin, which is the space that displays the ranges and units of measurement. The margin area has been grayed out in Figure 47 and Figure 49. It is not grayed out in the actual program.

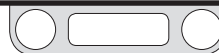

ER5000 — The ERTune™ Program: Basic Features

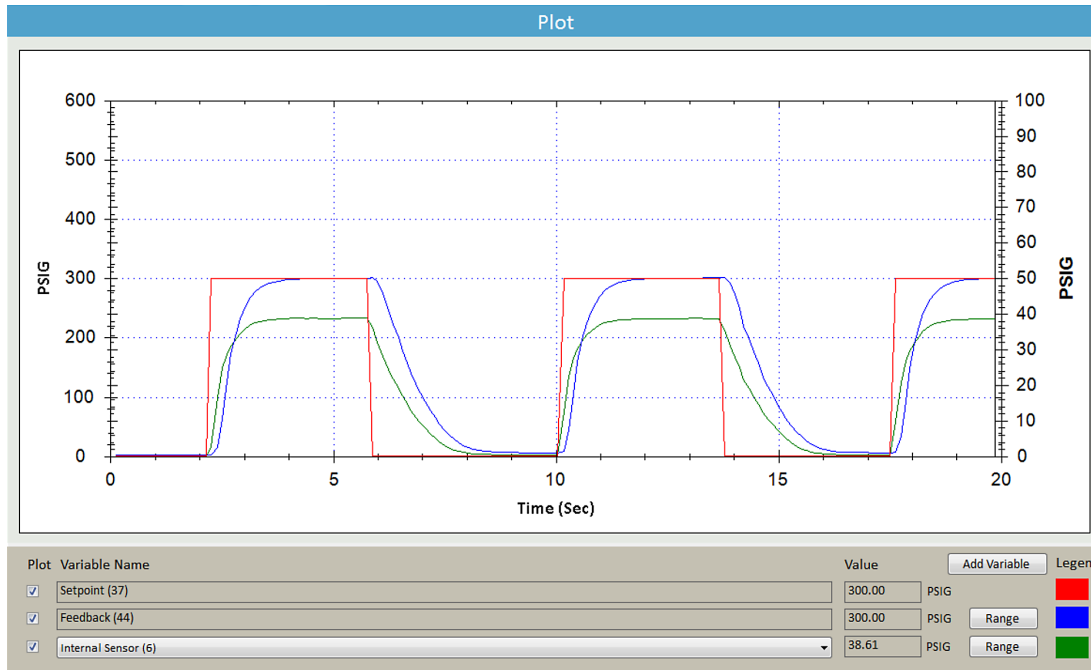

Figure 48: The Active Plot Screen Display

Figure 48 shows all the elements of the active Plot Screen display as the ER5000 responds to step changes in setpoint (red line).

The response is tracked through the feedback (blue line).

The main (left) vertical axis and the horizontal axis have been customized using the commands in The Plot Screen Menu — The Main Axis Menu.

In this application, the ER5000's internal sensor is also being tracked directly as an Added Variable (green line), which has been added to the Plot Screen using The Plot Screen Variable Controls.

The Secondary Axis displays the range for the internal sensor. The green line tracks to this range.



ER5000 — The ERTune™ Program: Basic Features

Resizing the Range Displayed by the Plot Screen Using the Mouse

IMPORTANT! Changes made to the Plot Screen display using the mouse or the Plot Screen menu commands only change the display of the Plot Screen. The ERTune™ program continues to track the full range of values for setpoint and feedback, even if the Plot Screen does not display them.

To change the actual range of feedback values tracked by the ERTune™ program, refer to the task *To change the range of feedback values tracked by the ERTune™ program*.

To toggle the display range of the vertical axis

1. Double-click anywhere within the Plot Screen. This toggles the display between a 0% to 100% display and a -20% to 120% display.

NOTE If your application makes full use of the display range, the -20% to 120% display makes it easier to visually track setpoints and responses near the 0% and 100% levels.

To zoom the vertical axis display

1. Click once within the Plot Screen at the level you want to set as the new maximum value, then a second time at the level you want to set as the new minimum value.

NOTE You may repeat this process to progressively increase the zoom level.

To return the vertical axis display to the default setting

1. Double-click anywhere within the Plot Screen.

NOTE You will return to the default display even if you have zoomed multiple times.



ER5000 — The ERTune™ Program: Basic Features

To zoom the display of both the vertical and horizontal axes

1. Drag a rectangular marquee within the active area of the Plot Screen.

NOTE The marquee selection must begin and end within the active area of the Plot Screen.

2. The Plot Screen zooms to display the marquee area.

NOTE You may repeat this process to progressively increase the zoom level.

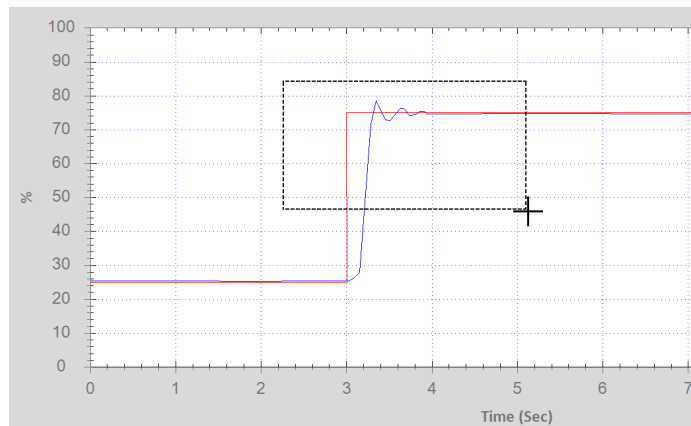

Figure 49: Marquee select in the Plot Screen

To return both axes to the default display settings

1. Double-click anywhere within the Plot Screen.

NOTE If you have zoomed multiple times using a marquee, each double-click will zoom out one level. Continue to double-click until you reach the default settings.

NOTE You can also zoom both axes in and out using the scroll wheel on a three-button mouse.

IMPORTANT! The Plot Screen should be stopped before resizing using a marquee selection.



ER5000 — The ERTune™ Program: Basic Features

The Plot Screen Menu Bar

The Plot Screen Menu Bar displays two menus and two buttons.

The Plot Screen Menus — The Main Axis Menu

The commands in this menu control the main (left) vertical and horizontal axes of the display.

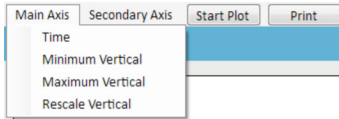

Time

This command allows you to set the number of seconds in one cycle of the Plot Screen. The default value is 10 seconds. The maximum cycle time is 1,000 seconds.

Minimum Vertical

This command allows you to set the minimum value of the main axis. The default value is 0 or the minimum of the current feedback range.

Maximum Vertical

This command allows you to set the maximum value of the main axis. The default value is 100 or the maximum of the current feedback range.

Rescale Vertical

This command resets the main axis to its original minimum and maximum values if they have been changed by the Maximum Vertical and/or Minimum Vertical commands.

The Plot Screen Menu — The Secondary Axis Menu

The commands in this menu control the secondary (right) axis of the display. This axis tracks the optional additional variables and displays independently from the main axis. It is not affected by changes to the main axis.

NOTE The secondary axis appears if you add the optional third variable (green line) to the Plot Screen using The Plot Screen Variable Controls. The range for this axis is set when you follow the steps To set or change the range for an added variable.

The secondary axis does not display the range of the optional fourth variable (black line) which can be added using The Plot Screen Variable Controls. This variable will be tracked within the scope of the range for the third variable.

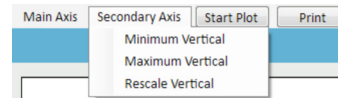

ER5000 — The ERTune™ Program: Basic Features

Minimum Vertical

This command allows you to set the minimum value of the secondary axis. The default value is 0 or the minimum of the range set for the third (green line) variable.

Maximum Vertical

This command allows you to set the maximum value of the secondary axis. The default value is 0 or the maximum of the range set for the third (green line) variable.

Rescale Vertical

This command resets the secondary axis to its original minimum and maximum values if they have been changed by the Maximum Vertical and/or Minimum Vertical commands.

The Plot Screen Buttons — The Start Plot/Stop Plot Button

This button toggles to start and stop the real-time display of the Plot Screen.

The Plot Screen Buttons — The Print Button

This button takes a snapshot of the current display and opens a window which displays the snapshot and the current tuning settings. You can print the window or save it as an Excel or PDF file.

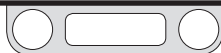

ER5000 — The ERTune™ Program: Basic Features

To change the horizontal axis using the Main Axis Menu

1. Select Main Axis -> Time. The Enter Time window opens.

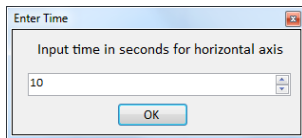

2. Enter the number of seconds for one cycle of the Plot Screen.
3. Click OK. The Plot Screen rescales to the new cycle time.

NOTE If you change the cycle time of the horizontal axis, you must use the Time command again if you wish to reset the axis to its original cycle time.

To change the main (left) vertical axis using the Main Axis Menu

1. Select Main Axis -> Minimum Vertical to change the minimum value for the main axis display.

Select Main Axis -> Maximum Vertical to change the maximum value for the main axis display.

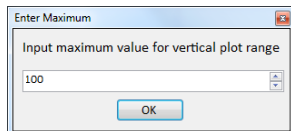
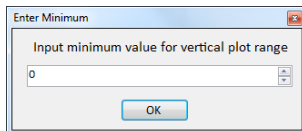

2. Enter a new value.
3. Click OK. The display rescales using the new value.

NOTE Repeat these steps for both menu items if you wish to set new values for both the minimum and maximum of the display.

To reset the main (left) vertical axis to its original values using the Main Axis Menu

1. Select Main Axis -> Rescale Vertical.
2. The main vertical axis of the Plot Screen returns to its original display range.

IMPORTANT! If you double-click in the Plot Screen after changing the vertical axis using the menu commands, the display will revert to its toggle between the original 0% to 100% range and -20% to 120% range and you will lose the values you set using the commands.



ER5000 — The ERTune™ Program: Basic Features

The Plot Screen Variable Controls

By default, the Plot Screen displays the setpoint and feedback values for your application. Using the controls in this area, you can track up to two additional variables.

NOTE These variables can also be added to data acquisition files generated during the session.

Figure 50: The Controls and Fields of the Plot Screen Variable Control Panel

Plot Check box
Click the box next to a variable to add it to the Plot Screen display. This also adds the variable to any data acquisition that takes place while it is checked. Uncheck the box to remove a variable from display and data acquisition. You can continue to monitor its value in the Value field.

Variable Name
Displays the names of all variables that can be tracked in the Plot Screen display. Setpoint and feedback are always tracked. Up to two additional variables can be added. You select each variable from the drop-down list. You must click the Plot check box for a variable to add it to the Plot Screen display.

Add Variable Button
Adds up to two additional variables, after which it is grayed out.

Legend
Shows the color of the line that represents each variable in the Plot Screen. These colors cannot be changed.
Setpoint: red line
Feedback: blue line
First Added Variable: green line
Second Added Variable: black line

Range Buttons
Click these buttons to open windows that allow you to set the minimum, maximum and unit of measurement for Feedback (44) and any additional variables. This range must accurately reflect the actual range of the input source. Refer to the **IMPORTANT!** note on the next page.

Value Field
Displays the current value for a variable and updates continually when the Plot Screen is active. Shows values even when the Plot check box is unchecked.

Plot	Variable Name	Value
<input checked="" type="checkbox"/>	Setpoint (37)	60.00 %
<input checked="" type="checkbox"/>	Feedback (44)	58.00 %
<input checked="" type="checkbox"/>	Internal Sensor (6)	55.00 %
<input checked="" type="checkbox"/>	Extra Analog Input 1 (77)	2000.00 psic

ER S... 735241



ER5000 — The ERTune™ Program: Basic Features

To track an additional variable

1. Click the Add Variable button.
2. A new line is added under Variable Name.
3. Click the Down Arrow (▼) to open the drop-down list.

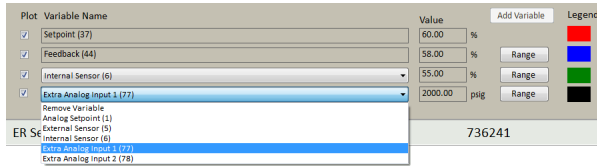

4. Select the input source you wish to track.

NOTE Values for the variable begin displaying immediately in the Value field to the right of the variable. These values display whether or not the variable is added to the Plot Screen display.

NOTE After you add the second additional variable, the Add Variable button is grayed out.

To add a variable to the Plot Screen display

1. Click the Plot check box to the left of drop-down list.
2. If this is the first added variable, the secondary axis appears on the right side of the Plot Screen.

NOTE The first added variable controls the range of the secondary (right) axis.

NOTE The first added variable appears as a green line. The second added variable appears as a black line.

3. The variable displays as a new line in the Plot Screen the next time the screen is active.

NOTE The variable is also added to data acquisition.

To set or change the range for an added variable

IMPORTANT! Changes made using the Range buttons in the Plot Screen Variable Controls change the actual range of values tracked by the ERTune™ program. Be sure the values you enter are correct for your application so that the values the program tracks are an accurate representation of system conditions.

1. Click the Range button to the right of drop-down list. The Define Variable Range window opens.

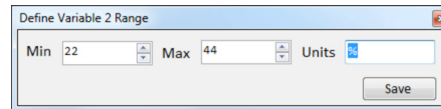

NOTE The window will be labeled as Variable 1 or Variable 2, depending on which added variable range is being defined.

2. Enter values for minimum, maximum and/or units of measure.
3. Click Save.

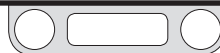

ER5000 — The ERTune™ Program: Basic Features

To optimize the display when both additional variables have been added to the Plot Screen

In many applications, the ranges for the first and second additional variable will vary widely. For example, it is a common practice to use the first additional variable to display feedback from the ER5000's 0–100 psig / 0–6.9 bar internal sensor and use the second additional variable to display feedback from an external sensor that has a range that is considerably larger, such as 0–30,000 psig / 0–2068 bar.

Since the display for the secondary axis is set by the range and unit of measurement for the first additional variable, a display based on psig / bar can give unsatisfactory results:

- If the secondary axis is set to the smaller range of the internal sensor, feedback from the external sensor will often be beyond the maximum of the display.
- If the secondary axis is set to the larger range of the external sensor, the feedback from the internal sensor will be difficult to differentiate.

The “best of both worlds” approach in this scenario is to set the range for both variables to 0–100%, rather than using a unit of measure based on pressure values. At this setting, both variables will display meaningful response curves in the Plot Screen despite the difference in their ranges.

The one disadvantage to this approach is that actual pressure values must be extrapolated from the percentage values generated by and displayed by the ERTune™ program. If it is more important for you to track pressure values, set both variables ranges to the actual pressure ranges of the sensors. You will be able to track the values in real time using the Value Field for each variable and by reviewing the data files from data acquisition. You will also be able to track the sensor selected as the first additional variable visually in the Plot Screen display.



ER5000 — The ERTune™ Program: Basic Features

To change which variable is being tracked

1. Click the Down Arrow (▼) to open the drop-down list for the additional variable you wish to change.

2. Select a different input source.

IMPORTANT! Check that the range is correct so the Plot Screen display will be accurate.

3. Click the Range button to the right of drop-down list. The Define Variable Range window opens.
4. If appropriate, enter new values for minimum, maximum and/or units of measure.

To remove a variable from the Plot Screen display

1. Uncheck the Plot check box to the left of drop-down list.

NOTE This also removes the variable from any data acquisition files generated during this session.

To stop tracking a variable

1. Click the Down Arrow (▼) to open the drop-down list for the variable you wish to remove.
2. Select Remove Variable.

To change the secondary axis using the Secondary Axis Menu

IMPORTANT! Changes made to the Plot Screen display using the Plot Screen menu commands only change the display of the Plot Screen. The ERTune™ program continues to track the full range of values entered for the variable(s) being tracked.

The secondary axis does not respond to interactions with the mouse.

1. Select Secondary Axis -> Minimum Vertical to change the minimum value of the secondary axis.
Select Secondary Axis -> Maximum Vertical to change the maximum value.

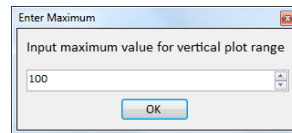
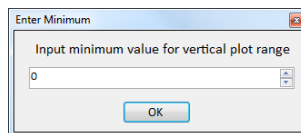

2. Enter a new value.
3. Click OK. The display rescales using the new value.

NOTE Repeat these steps for both menu items if you wish to set new values for both the minimum and maximum of the display.

To reset the secondary axis to its original values using the Secondary Axis Menu

1. Select Secondary Axis -> Rescale Vertical.
2. The secondary axis returns to its original range.



ER5000 — The ERTune™ Program: Basic Features

To change the range of feedback values tracked by the ERTune™ program

IMPORTANT! Changes made using the Range buttons in the Plot Screen Variable Controls change the actual range of values tracked by the ERTune™ program. Be sure the values you enter are correct for your application so that the values the program tracks are an accurate representation of system conditions.

1. Click the Range button to the right of drop-down list for Feedback (44). The Define Feedback Transducer Range screen opens.

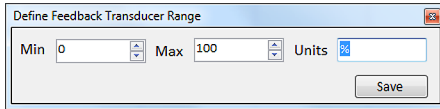

2. Enter values for minimum, maximum and/or units of measure.
3. Click Save.

To change the display of the main (left) axis to the new range

1. Select Main Axis -> Rescale Vertical.
2. The main axis rescales to display the new range.

IMPORTANT! If you double-click in the Plot Screen after changing the main axis using the Plot Screen Variable Controls, the display will toggle between a display of 0% to 100% and a display of -20% to 120% of the new minimum and maximum values.



ER5000 — The ERTune™ Program: Basic Features

The Footer Area

The Footer Area at the bottom of the display screen shows the following information:

- Model number of the ER5000
- Serial number of the ER5000
- Node Address of the ER5000
- Model Number of the regulator
- Serial Number of the regulator.

If you have multiple controllers daisy-chained in a network, the information in the footer tells you which controller is currently communicating with the ERTune™ program.



ER5000 — The ERTune™ Program: Basic Features

The Tuning Tab: Controls and Functions for Tuning the ER5000

The controls in the Tuning Tab allow you to manually tune the ER5000 to achieve optimal performance for your application. The first time you open the ERTune™ program, the Tuning Tab will display the PID values that were set at the factory or that were downloaded to the controller during setup.

WARNING

Most controls in the ERTune™ program operate in real time and have an immediate effect on system performance. Be aware of system limitations before you change the settings of a control. Depending on the application, these changes may upset the process control, which may result in personal injury or property damage.

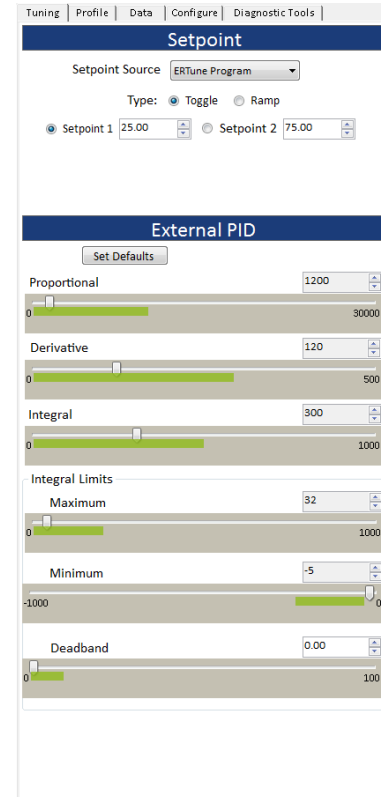

ER5000 — The ERTune™ Program: Basic Features

Tuning the ER5000

Before You Begin

If you are new to PID controllers, be sure that you have read the *How It Works* and *Glossary of Terms* sections of this manual, as well as all cautions and warnings in the *Safety, Installation & Operations Precautions* section, before you begin.

WARNING

Most controls in the ERTune™ program operate in real time and have an immediate effect on system performance. Be aware of system limitations before you change the settings of a control. Depending on the application, these changes may upset the process control, which may result in personal injury or property damage.

Tuning inevitably involves some trial and error and undesired effects of the tuning process, such as overshoot, may tax the limitations of the system.

You will achieve the best result if you tune the ER5000 at a number of different pressure ranges, from maximum system limits to minimum anticipated step change. Tuning the ER5000 at a number of intermediate ranges will give you a fuller picture

of the controller's response characteristics. Your final tuning should be done using a range that approximates typical operating conditions.

Understand the characteristics of your application. This will help you select the correct setpoint source for tuning the ER5000. Tuning is most commonly performed using a toggled step change. You may find that a ramp configuration gives a more accurate representation of your system. You can also use the Profile Builder to create a more complex series of setpoint changes to mimic typical operational conditions.

Understand what your primary goals are for the ER5000's response. Tuning inevitably involves a trade-off between speed and stability of response. Typical goals include:

- Fastest response
- Minimizing overshoot
- Minimizing offset
- Minimizing settling time.

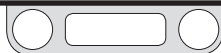

ER5000 — The ERTune™ Program: Basic Features

The Setpoint Panel

The fields in this panel allow you to select a setpoint source for tuning the ER5000 and set the parameters of the tuning session.

Selecting a Setpoint Source

The top panel of the Tuning Tab allows you to select a setpoint source and set the parameters for the tuning.

IMPORTANT! The setpoint source you select for tuning is also the setpoint source for the controller during standard operation.

To select a setpoint source

1. Click the Down Arrow (▼) of the Setpoint Source drop-down list.
2. Select your setpoint source from the four choices:

Analog Input Setpoint Source

This is the default setting. When this is selected, the ER5000 accepts setpoint from an analog input (4–20 mA or 1–5V analog signal). The ER5000XV-1 model accepts a 0–10V analog signal.

ERTune Program

When this is selected, the ERTune™ program generates setpoints based on values you have entered in the program. There are two tuning modes: Toggle and Ramp.

Profile

When this is selected, the ER5000 follows the command sequence of the Profile that is currently loaded in the ER5000.

External Device Setpoint Source

When this is selected, the ER5000 accepts digital setpoints (USB or RS485) from an external device such as a PC. The setpoint source must be separate from the PC that is currently running the ERTune™ program.

ERTune Program

Toggle Mode Setpoint Source

In Toggle Mode, the ERTune™ program generates step changes between two setpoints. Typically, setpoint values are set at 25% and 75%. Optimal tuning generally requires multiple sessions at different toggle settings.

Setpoint

Setpoint Source: ERTune Program

Type: Toggle Ramp

Setpoint 1: 25.00 Setpoint 2: 75.00

IMPORTANT! Final tuning should always be done at pressures that accurately reflect the actual operational conditions of your application.

To set the two setpoint values

1. Enter a minimum and maximum value in the Setpoint 1 and Setpoint 2 entry fields.

You can enter minimum and maximum values in either field.

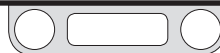

ER5000 — The ERTune™ Program: Basic Features

To change a setpoint value during tuning

1. Enter a new value in either field.

This may be done at any time.

The timing of setpoint changes is controlled by the user. You may use the radio buttons in the Tuning Tab or the Space Bar on your keyboard to activate the toggle function.

To toggle setpoint using the Tuning Tab

1. Click the Start Plot button to activate the Plot Screen.
2. Click the Setpoint 1 or Setpoint 2 radio button.

The Plot Screen steps the setpoint to the value and the ER5000 responds to the change.

To toggle setpoint using the Space Bar

1. Click the Start Plot button to activate the Plot Screen.
2. Click in the white space below the Setpoint 1 and Setpoint 2 entry fields. The words Hit Space Bar to Toggle Appear.
3. Press the Space Bar. Each press toggles the setpoint value.

NOTE If you click outside of the Tuning Tab, for example to zoom the Plot Screen, the toggle function is turned off and the words “Hit Space Bar to Toggle” disappear. Click below the Setpoint fields to restore the setpoint toggle function.

ERTune Program

Ramp Mode Setpoint Source

In Ramp Mode, the ERTune™ program changes the setpoint steadily from the current level to a target level over a set period of time, generating a gradual rise or fall in the Plot Screen.

The screenshot shows a control panel titled "Setpoint" with a dark blue header. Below the header, there is a "Setpoint Source" dropdown menu currently set to "ERTune Program". Underneath, there are two radio buttons for "Type": "Toggle" (unselected) and "Ramp" (selected). Below the radio buttons, there are two input fields: "Rate" with a value of "5" and a unit of "%/sec", and "Ramp to" with a value of "75" and a unit of "%". At the bottom of the panel is a "Start" button.

NOTE The unit of measurement will default to the unit that is currently set for the main axis.

To set the target value of a ramp change

1. Enter a value in the Ramp to entry field.

To set the rate of a ramp change

1. Enter a value in the Rate entry field.

To initiate a ramp change

1. Click the Start button.

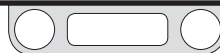

ER5000 — The ERTune™ Program: Basic Features

Profile Setpoint Source

When this is selected, the ER5000 uses a Profile to control setpoint changes. The Profile must be loaded in the controller.

The screenshot shows a control panel for the Profile Setpoint Source. At the top, there is a dark blue header with the word "Setpoint" in white. Below the header, the "Setpoint Source" is set to "Profile" in a dropdown menu. The "Current Segment" is "Step 2 Dwell" and the "State" is "Stop". The "Loop Count" is "0". At the bottom, there are three buttons: "Start", "Stop", and "Resume".

By default, the Profile that is currently saved on the controller's control board is uploaded to the ERTune™ program when the program opens.

- To ensure that the Profile displayed in The Profile Window matches the Profile in the controller, click the Upload button in The Profile Panel.
- To load a Profile that was previously saved to the PC, click the Open button in The Profile Panel, locate the Profile you wish to use, then click the Download button.
- You may also build a Profile using The Profile Builder Panel, then click the Download button.

To tune the ER5000 using a Profile

1. Click the Profile Tab.
2. Load a Profile into the Profile Tab. You may upload it from the ER5000, create it using the Profile Builder or open a previously saved Profile.
3. Click the Tuning Tab.
4. Click the Start button.
5. The Profile loads and the Tuning Tab displays the current segment, the current state and the current loop count of the Profile as it progresses through the commands.

The Profile will run until it reaches the End command.

You can view the entire Profile in The Profile Window.

To pause the Profile

1. Click the Stop Button.

To resume running the Profile

1. Click the Resume Button.



ER5000 — The ERTune™ Program: Basic Features

The PID Control Panel

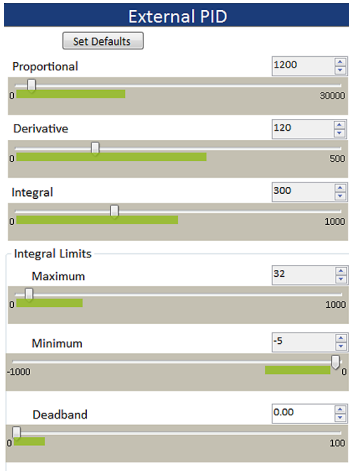

The controllers in the PID Control Panel give you precise, intuitive control over the Proportional, Derivative and Integral settings for the ER5000. The ER5000 also features exclusive Integral Limits controllers which restrict Integral based on specific real-time operational conditions. These allow you to use high Integral settings without the risk of excessive overshoot, ringing or windup.

NOTE The title of the PID Control Panel displays the current Control Mode of the ER5000.

NOTE If the ER5000 is set to Cascade Mode, the PID Control Panel has separate displays for the internal and external PID controllers. Click the Cascade Show External?/Cascade Show Internal? button to toggle between these two displays within the panel.

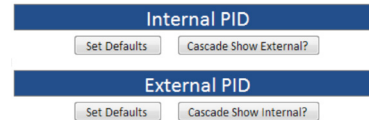

NOTE The slider ranges shown for each controller do not correspond to any actual mechanical setting within the ER5000. They are set to give a level of precision that is appropriate for each term: a wide range for Proportional and a more restrictive range for Integral and Derivative.

The green overlays highlight recommended ranges for each controller. Most applications for the ER5000 will fall within these ranges. Staying within the recommended ranges minimizes tuning effects, such as overshoot and windup, which can prove daunting to inexperienced users. However, if your application calls for settings that fall outside the highlighted ranges, you should not hesitate to use them.

(continued next page)

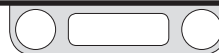

ER5000 — The ERTune™ Program: Basic Features

The ER5000 can be reset to the default PID settings at any time.

To reset the ER5000 to its default PID settings

1. Click the Set Defaults button. The Set Defaults window opens.

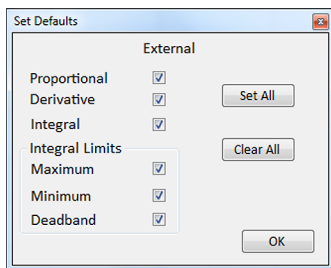

2. Check or uncheck the boxes to select any or all of the control settings to be reset.
3. Click OK. The selected settings will return to their default values.

The ERTune™ program was designed to make the tuning process intuitive for all users. If you are new to PID tuning, be sure you have read the Tuning a PID Controller section. The Rules of Thumb for each component can be applied as specific recommendations or tips, for how to use each controller in the PID Control Panel.

The Proportional Controller

This slider sets the Proportional term for the ER5000.

Proportional Tuning Tips

- In most applications, the first step in tuning is to see how high the Proportional term can be increased.
- The primary goal when increasing Proportional is to minimize the response time.
- Proportional should be gradually increased until overshoot or ringing become too pronounced. Then it should be stepped back until they are minimized.
- PID parameters tend to be logarithmic. This means that small changes in the slider setting usually result in no appreciable change to the response curve. A set of values such as 200, 400, 800, 1200, 2000 will allow you to quickly find the applicable range for your Proportional term. You can fine tune from there.
- For most applications, the Proportional term has the greatest effect on performance.
- Proportional is a direct function of the current error, so its value approaches zero as error approaches zero.



ER5000 — The ERTune™ Program: Basic Features

The Derivative Controller

This slider sets the Derivative term for the ER5000.

Derivative Tuning Tips

- In most tuning applications, the Derivative term is first zeroed out so the effect of adjustments to the Proportional term is not damped. It is then added gradually.
- In most tuning applications, the Derivative term will fall in the range of 25–250.
- The Derivative term should be increased to reduce instability, such as overshoot or ringing and to decrease settling time.
- If increasing Derivative term slows down rise time without diminishing overshoot/ringing, the Proportional term should be decreased instead.
- Paradoxically, higher Derivative settings can make some systems unstable by increasing sensitivity to transient changes (noise) in the operating environment. If you note that the controller is not remaining in Stable State after setpoint has been reached, try reducing the Derivative term.

The Integral Controller

This slider sets the Integral term for the ER5000.

Integral Tuning Tips

- In most tuning applications, the Integral term is first zeroed out so the effect of adjustments to the Proportional term is not amplified. It is then added gradually.
- In most tuning applications, the Integral term will fall in the range of 50–800.
- PID parameters tend to be logarithmic. This means that small changes in the slider setting usually result in no appreciable change to the response curve. A set of values such as 100, 200, 400, 800, will allow you to quickly find the applicable range for your Integral term. You can fine tune from there.
- The Integral Limits Controllers allow you to set a higher Integral term, then limit undesired effects using these additional controls. This allows you to accelerate the response while minimizing unwanted side effects.

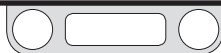

ER5000 — The ERTune™ Program: Basic Features

The Integral Limits Controllers

These three controllers allow you to set a higher Integral term while minimizing detrimental effects such as windup.

Maximum

This controller sets the limit for positive errors (setpoint minus feedback is positive) that can accumulate for the Integral term during error correction, typically after a change from a low to a high setpoint. The Integral will stop adding positive value when it reaches the level set by this limit, regardless of feedback.

Minimum

This controller sets the limit for negative errors (setpoint minus feedback is negative) that can accumulate for the Integral term during error correction, typically after a change from a high to a low setpoint. The Integral will stop subtracting negative value when it reaches the level set by this limit, regardless of feedback.

Deadband

This controller sets a range around the setpoint where the Integral term will not respond to error.

The deadband range is measured as a percentage of the full range of the feedback. For example, a setting of one percent (1%) creates a deadband range from one percent above (+1%) to one percent below (-1%) the setpoint.

The Deadband controller prevents system noise or a series of small transient errors, from accumulating in the Integral term to the point that the ER5000 is activated. In some applications, accumulation of these errors can cause the ER5000 to be in a perpetual state of activation.

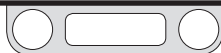

ER5000 — The ERTune™ Program: Basic Features

A Typical Step Tuning Example

This section is an example of the proper sequence of steps to follow, as well as typical settings, for a step tuning session for the ER5000.

IMPORTANT! The PID settings downloaded during setup provide excellent control for most applications. In some cases, minor adjustments may be required to optimize performance. Refer to Table 1: Effect of P, I and D Increases on Response Curve of Controller in the How It Works section for basic tips on adjusting the PID settings.

If, however, you find that these minor adjustments do not give satisfactory results, zero out the controllers, refer to the Rules of Thumb for PID Tuning as well as the detailed Tuning Tips beginning on page 149 and build your own configuration “from scratch.” You can return to the default settings at any time by following the steps To reset the ER5000 to its default PID settings.

Tuning is a gradual process, with repeated cycles of changing settings and monitoring system response. Most of the steps in this example will be repeated multiple times until the desired response curve is seen in the Plot Screen.

The Initial Settings

- Setpoint Source: ERTune™ Program
- Type: Toggle
- Setpoint 1: 25%
- Setpoint 2: 75%
- Proportional: 400
- Derivative: 0
- Integral: 0
- Maximum: 0
- Minimum: 0
- Deadband: 0

To activate the Plot Screen

1. Click the Start Plot Button.

To toggle the setpoint

1. Click in the white space below the Setpoint 1 and Setpoint 2 entry fields. The words Hit Space Bar to Toggle appear.
2. Press the Space Bar. Each press toggles the setpoint.

(continued next page)

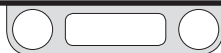

ER5000 — The ERTune™ Program: Basic Features

To set the Proportional Term

1. Toggle the setpoint.
2. Note rise time, stability and settling time of the ER5000. The response of the ER5000 should mirror the setpoint step change as closely as possible.

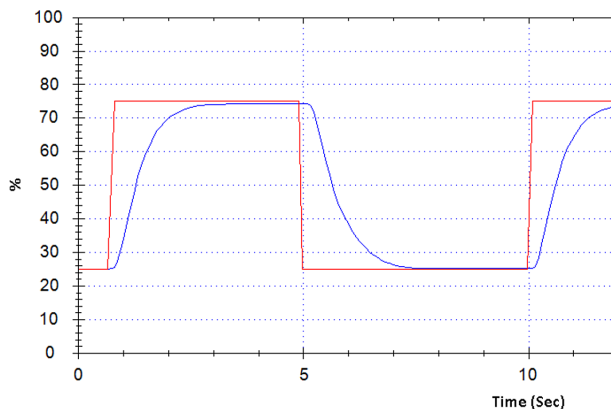

Figure 51: Typical Tuning: Initial PID Settings

Response is stable, but rise time and settling time are slow. Increasing Proportional will speed up response time.

3. Move the Proportional slider to the right or enter a higher number in the field next to the slider. Refer to Proportional Tuning Tips.

4. Continue to toggle the setpoint. Note the change in the response of the ER5000.
5. Continue to move the Proportional slider right until you begin to see excessive overshoot/ringing or until there is no appreciable improvement in rise time.

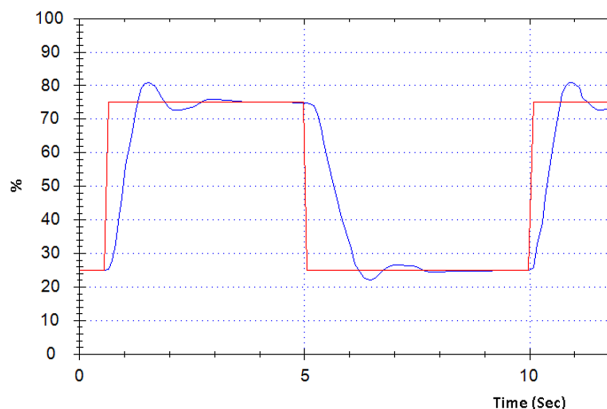

Figure 52: Typical Tuning: Proportional Increased

Response is faster, but overshoot and ringing are at unacceptable levels.

(continued next page)



ER5000 — The ERTune™ Program: Basic Features

- Step back the Proportional slider to minimize unwanted effects.

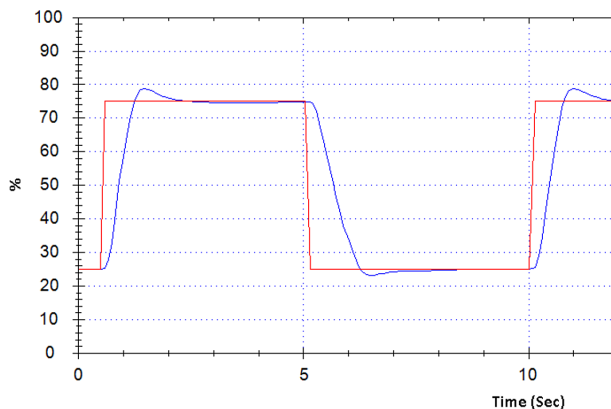

Figure 53: Typical Tuning: Proportional Optimized

Overall, the response is quick and stable. Derivative will be used to correct the small amount of residual overshoot.

To add the Derivative Term

- Move the Derivative slider slightly to the right or enter a higher number in the field next to the slider.
- Toggle the setpoint and note the change to the response curve.

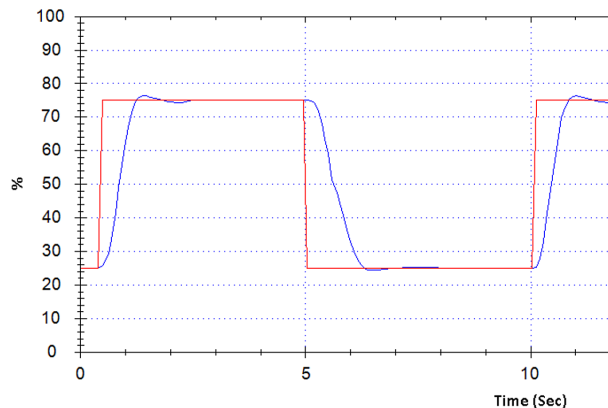

Figure 54: Typical Tuning: Derivative Added

A higher Derivative setting will completely correct the overshoot.

(continued next page)



ER5000 — The ERTune™ Program: Basic Features

- Continue to increase the Derivative term until you have stabilized the response.

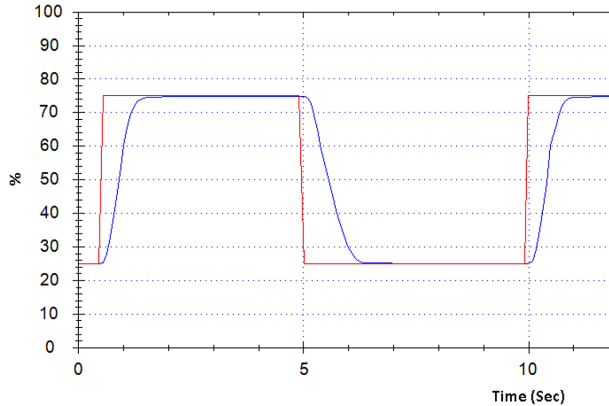

Figure 55: Typical Tuning: Critically Damped
Response is now both quick and stable.

- Repeat the process until you note the effects of overdamping.

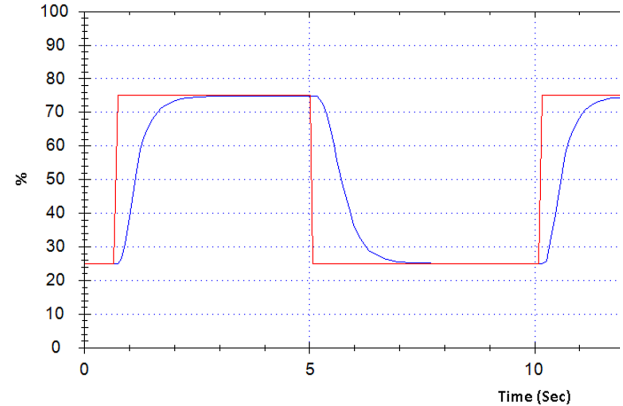
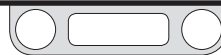

Figure 56: Typical Tuning: Overdamped Response
A Derivative setting that is too high results in a slower rise time.

- Step back the Derivative slider or enter a smaller number in the field, until instability reaches unacceptable levels.



ER5000 — The ERTune™ Program: Basic Features

To add the Integral Term

1. Move the Integral slider to the right or enter a value of 50.
2. Toggle the setpoint and note the change in system response.
3. Increase Integral until you note the signs of instability.
4. Step back the Integral and begin using the Integral Limits.

To limit the effect of the Integral Term using the Integral Limits

1. Increase magnification in the Plot Screen to zoom in closely at the level of Setpoint 2 (75%). Refer to *Resizing the Range Displayed by the Plot Screen Using the Mouse*.
2. Toggle the setpoint to Setpoint 2.
3. Wait for the system to reach a stable state.
4. Look closely for offset between the setpoint and feedback level once the system reaches stable state.

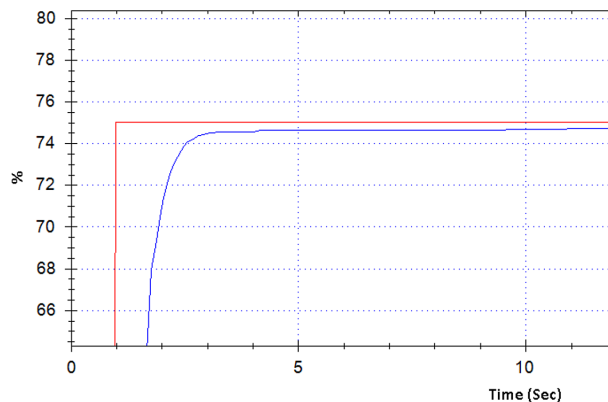

Figure 57: Typical Tuning: Offset at Setpoint 2
Stable state is reached slightly below the setpoint.

(continued next page)



ER5000 — The ERTune™ Program: Basic Features

5. If there is offset, move the Maximum slider slightly to the right, to increase the level of positive Integral that will be allowed to accumulate.
6. Repeat until the offset is eliminated.

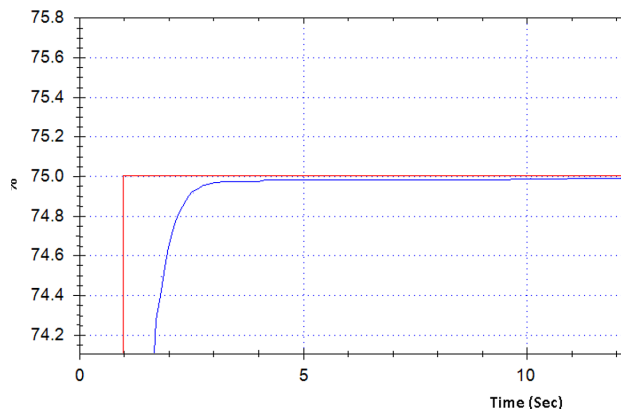

Figure 58: Typical Tuning: Offset Corrected

Even at a high level of magnification, there is now no offset between setpoint and feedback.

7. When you are satisfied with the response at Setpoint 2, return to default zoom in the Plot Screen. Then zoom in closely at the level of Setpoint 1 (25%).

8. Look closely for offset between the setpoint and feedback level once the system reaches stable state. If there is offset, move the Minimum slider slightly to the left, to increase the level of negative Integral that will be allowed to accumulate.
9. Repeat until the offset is eliminated.

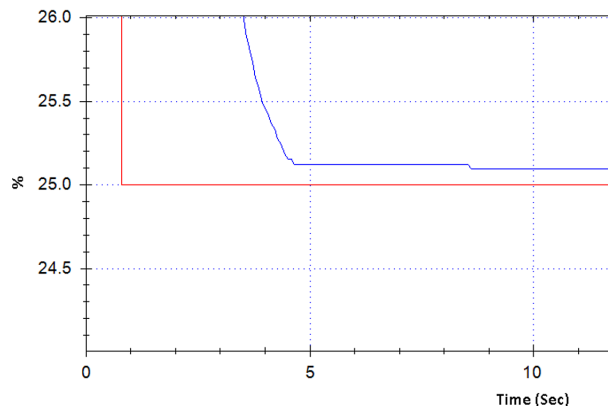

Figure 59: Typical Tuning: Checking for Offset at Setpoint 1

As was true for Setpoint 2, some offset correction will be required at Setpoint 1.

10. When you are satisfied with the response at Setpoint 1, return to default zoom in the Plot Screen. Toggle between the two setpoints and note stability, accuracy and response time.

(continued next page)



ER5000 — The ERTune™ Program: Basic Features

11. If you note a delayed response to a change in setpoint or that the changes to Integral Limits have re-introduced overshoot that slowly settles into setpoint, these are signs of Integral windup. You will need to decrease the Integral Limits to correct this.

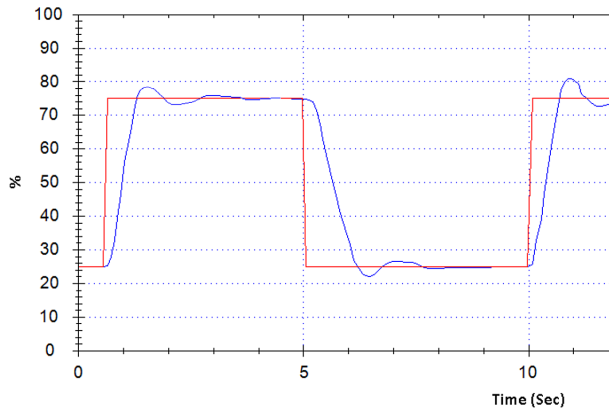

Figure 60: Typical Tuning: Integral Windup

Overshoot with a pronounced settling time in a previously stable response is a sign that the Integral Limit levels are too high, allowing Integral windup to affect the response.

NOTE If you find that you cannot eliminate offset and windup without increasing instability, you will need to reduce the Integral Term.

To add Integral Deadband

1. Allow the ER5000 to cycle through the Plot Screen several times at the current setpoint.
2. If the ER5000 activates repeatedly while the setpoint remains at the same level, move the Deadband slider to the right or enter a number in the field next to the slider.
3. Increase the value slowly, in one percent increments, until the unwanted activation stops.

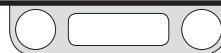

ER5000 — The ERTune™ Program: Basic Features

Cascade Tuning

Cascade tuning is complex and can prove daunting for the inexperienced user and should only be attempted if the system is persistently unstable.

NOTE When the ER5000 is set to Cascade Mode, the PID Control Panel has separate displays for the internal and external PID controllers. Click the Cascade Show External?/Cascade Show Internal? button to toggle between these two displays within the panel.

Cascade Tuning Tips

- Cascade Mode typically only requires tuning for the PID settings of the External loop.
 - For proper operation in Cascade Mode, the defaults for the Integral Limits of the External loop are: Maximum: 32767; Minimum: 0. These settings are optimal for most applications and should not be changed unless you have verified that this is required by your application.
 - Increasing the Integral Term of the External PID generally has a more pronounced effect on rise time than increasing the Proportional Term. In some applications, increasing the Proportional Term of the External PID in Cascade tuning may slow down rise time.
- Alternate between increasing the Integral Term, then increasing the Proportional Term, until you begin to see instability in the response of the ER5000. At this point, back off the values slightly.
 - The Derivative Term should be added gradually to the External PID after Integral and Proportional values have been set. Unwanted effects from too much Derivative may develop quickly, so be prepared to step back the Derivative slider as soon as they are noted.

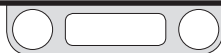

ER5000 — The ERTune™ Program: Basic Features

The Profile Tab: Creating Multi-Step Command Sequences

Profiles are multi-step command sequences for the ER5000. They require no previous programming experience on the part of the user to create and guide the ER5000 through everything from a simple start/stop operation to a sequence of setpoint changes that can include up to one hundred command lines and control loops that can run indefinitely.

The Profile Builder Panel in the Profile Tab provides a simple, intuitive interface for creating and editing Profiles. Profiles are built one command line (called a segment) at a time. Commands are chosen from a drop-down list; the three most commonly-used commands (Ramp, Dwell and Step) can also be quickly selected by clicking a button. Parameters for each command are set using simple text entry fields and select lists.

Completed Profiles are downloaded to the control board of the ER5000. They can also be saved to external text files for future use. Profiles can be uploaded from the ER5000 or opened from the PC in the ERTune™ program and used as the setpoint source for tuning the controller.

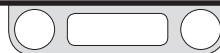
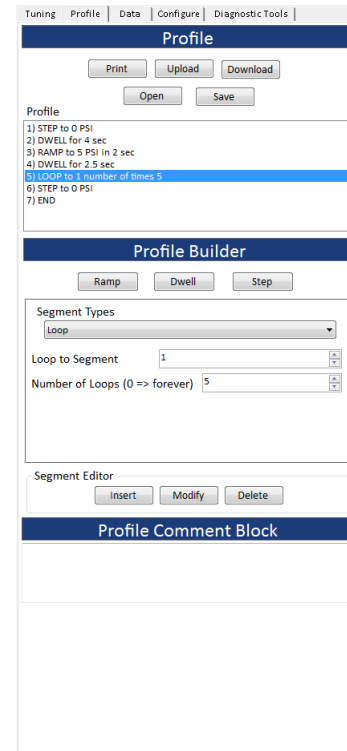

ER5000 — The ERTune™ Program: Basic Features

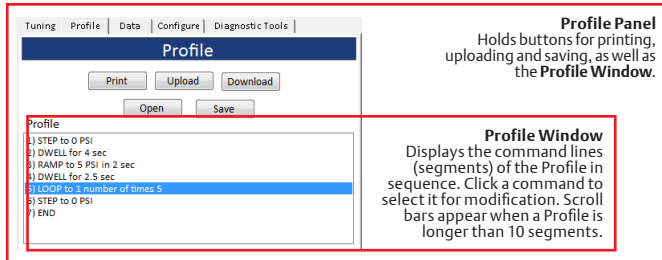

The screenshot shows the 'Profile' window with a menu bar (Tuning, Profile, Data, Configure, Diagnostic Tools) and a title bar 'Profile'. Below the title bar are buttons for 'Print', 'Upload', 'Download', 'Open', and 'Save'. The main area contains a list of profile segments: 1) STEP to 0 PSI, 2) DWELL for 4 sec, 3) RAMP to 5 PSI in 2 sec, 4) DWELL for 2.5 sec, 5) LOOP to 1 number of times 5, 6) STEP to 0 PSI, 7) END. The fifth segment is highlighted in blue.

Profile Panel
Holds buttons for printing, uploading and saving, as well as the **Profile Window**.

Profile Window
Displays the command lines (segments) of the Profile in sequence. Click a command to select it for modification. Scroll bars appear when a Profile is longer than 10 segments.

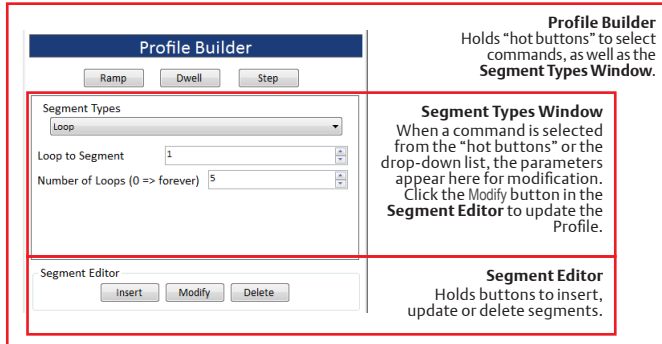

The screenshot shows the 'Profile Builder' window with a title bar 'Profile Builder' and buttons for 'Ramp', 'Dwell', and 'Step'. Below the title bar is a 'Segment Types' dropdown menu set to 'Loop'. Underneath are input fields for 'Loop to Segment' (value 1) and 'Number of Loops (0 => forever)' (value 5). At the bottom is a 'Segment Editor' section with 'Insert', 'Modify', and 'Delete' buttons.

Profile Builder
Holds “hot buttons” to select commands, as well as the **Segment Types Window**.

Segment Types Window
When a command is selected from the “hot buttons” or the drop-down list, the parameters appear here for modification. Click the Modify button in the **Segment Editor** to update the Profile.

Segment Editor
Holds buttons to insert, update or delete segments.

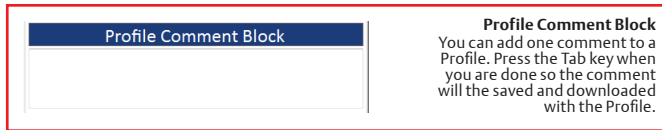

The screenshot shows a 'Profile Comment Block' window with a title bar 'Profile Comment Block' and a large empty text area for entering a comment.

Profile Comment Block
You can add one comment to a Profile. Press the Tab key when you are done so the comment will be saved and downloaded with the Profile.

The Panels and Windows of the Profile Tab

The Profile Panel has buttons for printing the current Profile, uploading from or downloading to the ER5000 and opening from or saving to the PC. *The Profile Window* displays the command lines (segments) of the Profile. Selecting a segment in the Profile Window opens it for editing in the Profile Builder Panel.

The Profile Builder Panel has a drop-down select list of commands, as well as three “hot” buttons to quickly select the three most commonly-used commands. Parameters for each command are displayed and edited in the **Segment Types Window** and the segment can be inserted into the Profile, modified or deleted using buttons in the **Segment Editor Window**.

The Profile Comment Block Panel allows you to add a comment which is included as part of the Profile when it is downloaded or saved.



ER5000 — The ERTune™ Program: Basic Features

The Profile Panel

The top panel of the Profile Tab shows the currently loaded Profile.

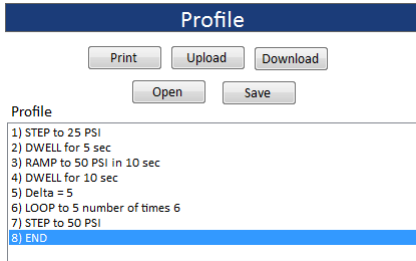

NOTE If no Profile has been built for the ER5000, the default Profile will show a single END command in the Profile window. Every Profile must include the END command as its final segment.

CAUTION

A Profile will not run the ER5000 until it has been downloaded to the controller's control board. Unlike most fields and controls in the ERTune™ program, the Profile Builder does not have real-time control over the ER5000.

A Profile must be downloaded or saved when it is complete! Otherwise it will be deleted when you exit the ERTune™ program. Profiles are only stored in your computer's short term memory until they are downloaded or saved.

The Profile Window

The Profile Window shows the command lines of the currently loaded Profile. Selecting a command in the window opens it for editing in the Profile Builder. Scroll bars appear when the line count goes beyond the frame of the window.

There are also five buttons in the panel:

Print

Prints the contents of the Profile Window.

Upload

Loads the Profile from the control board of the ER5000 into the Profile Window.

Download

Downloads the contents of the Profile Window to the control board of the ER5000.

Open

Opens a previously saved Profile. Profiles are saved in a text format with the .sav file extension.

Save

Saves the contents of the Profile Window to a text file. Profiles are saved to the PC with the .sav file extension.

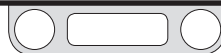

ER5000 — The ERTune™ Program: Basic Features

The Profile Builder Panel

The middle panel of the Profile Tab holds the tools for adding, modifying and deleting segments of the Profile.

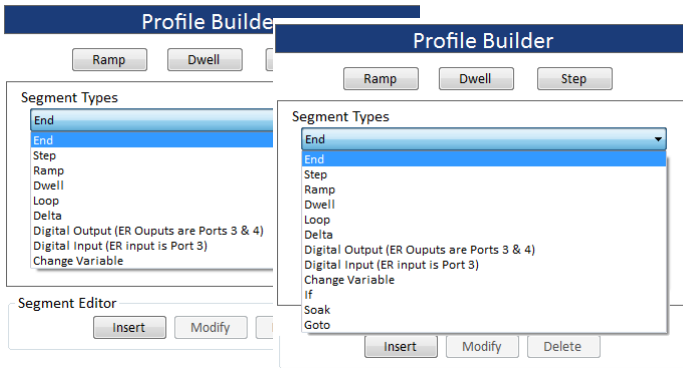

Figure 61: Drop-down Command Lists for “S” Model and “F” Model ER5000s

The Segment Types Window

The Segment Types Window displays the editing fields for a command when it is selected from the drop-down list or by clicking one of the three buttons. The Ramp, Dwell and Step buttons allow you to quickly select the three most commonly used commands.

The Segment Editor Window

There are three buttons in this window.

Insert

This button adds a new segment to the Profile. The new segment is added above the segment that is currently selected in the Profile Window.

Modify

This button saves the edits made to an existing segment.

IMPORTANT! You must click this button to update the Profile.

Delete

This button deletes the currently selected segment in the Profile Window.



ER5000 — The ERTune™ Program: Basic Features

CAUTION

If you are modifying a Profile that has been previously downloaded or saved, you must click the **Download** button to download the updated Profile to the ER5000 or the **Save** button to save the updated Profile to the PC, when all modifications have been done. Otherwise, the updates will be lost when you close the ERTune™ program.

A Profile must be downloaded to the ER5000 if you wish to use it to run the controller.

To add a command line (segment) to a Profile

1. Click within the Profile Window to select a segment of the current Profile. The new command will be added BEFORE the segment you select.
2. Select a command from the drop-down Segment Types list.
OR
Click the Ramp, Dwell or Step button. These three commands, which are the most commonly used Profile segments, can be accessed directly using these “hot” buttons.
3. The Segment Types Window displays the entry fields to set the parameter values for the command.
4. Enter or select the values for the command.
5. Click the Insert Button. The command is added to the Profile Window above the selected segment.

To modify a segment in a Profile

1. Click within the Profile Window to select the segment. It may be necessary to scroll to locate the segment line.
2. The parameter entry fields will appear in the Segment Type Window with the current values displayed.
3. Enter the new values.
4. Click the Modify Button. The segment will be updated with the new values.

To delete a segment from a Profile

1. Click within the Profile Window to select the segment. It may be necessary to scroll to locate the segment line.
2. Click the Delete Button. The segment is immediately deleted.

To add comments to a Profile

1. Enter comments in the Profile Comments Block. The Comments Block is the bottom panel of the Profile Tab.
2. Press the Tab key when you are done.

 **NOTE** Each Profile has a single comment block to hold all comments.

To use a Profile to control the ER5000

1. Check that the Profile has been downloaded to the controller.
2. Select Profile in the Setpoint Source field of the Tuning Tab. Refer to *Selecting a Setpoint Source*.
3. Click the Start button.

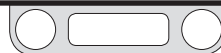

ER5000 — The ERTune™ Program: Basic Features

The Commands in the Profile Builder

IMPORTANT! The unit of measurement for the setpoint value parameter in these commands matches the unit of measurement for feedback set during Step 7 of the Setup Process or when you followed the steps To change the range of feedback values tracked by the ERTune™ program.

Step

Initiates a step setpoint change to the value entered in the Setpoint to Step to entry field.

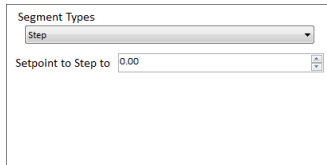

Segment Types
Step

Setpoint to Step to 0.00

Ramp

Initiates a ramp setpoint change to the value entered in the Setpoint to Ramp to entry field. The duration, in seconds, of the ramp-up or ramp-down is set in the Time to Ramp (sec) entry field.

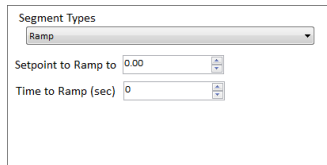

Segment Types
Ramp

Setpoint to Ramp to 0.00

Time to Ramp (sec) 0

Dwell

Maintains the current setpoint for the amount of time, in seconds, entered in the Time to Dwell (sec) entry field.

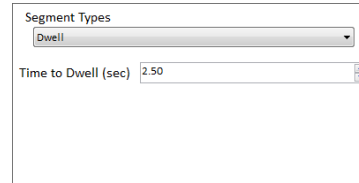

Segment Types
Dwell

Time to Dwell (sec) 2.50

Loop

Allows the Profile to loop multiple times through a sequence of command segments, beginning with the segment entered in the Loop to Segment entry field.

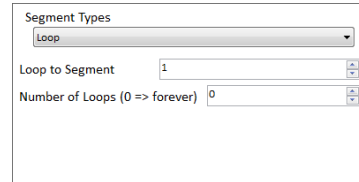

Segment Types
Loop

Loop to Segment 1

Number of Loops (0 => forever) 0

NOTE The command sequence will run the number of times entered in the Number of Loops entry field. A value of 0 in the Number of Loops entry field will cause the loop to run perpetually.



ER5000 — The ERTune™ Program: Basic Features

Delta

Initiates a step setpoint change by the value entered in the Delta Amount entry field. The value entered in the Delta Amount entry field can be positive or negative.

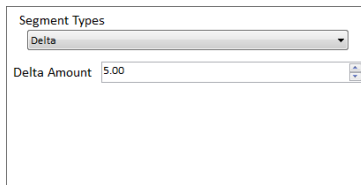

The screenshot shows a software interface for configuring a Delta command. It features a dropdown menu labeled "Segment Types" with "Delta" selected. Below this is a text input field labeled "Delta Amount" containing the value "5.00".

The Delta command can be used together with the Loop command as a programming shortcut to move the setpoint to a target level through a series of smaller setpoint step changes.

In the Profile below, segments 3 through 5 combine to increase pressure from 50 psig to 70 psig over 5 loops and segments 6 through 8 return the pressure to 50 psig over four loops.

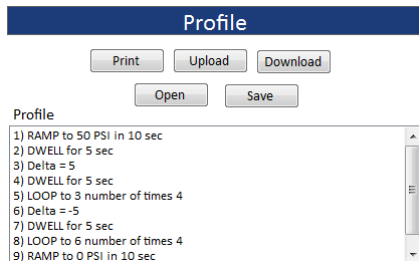

The screenshot shows a "Profile" configuration window. At the top, there are buttons for "Print", "Upload", "Download", "Open", and "Save". Below these buttons is a list of profile segments:

- 1) RAMP to 50 PSI in 10 sec
- 2) DWELL for 5 sec
- 3) Delta = 5
- 4) DWELL for 5 sec
- 5) LOOP to 3 number of times 4
- 6) Delta = 5
- 7) DWELL for 5 sec
- 8) LOOP to 6 number of times 4
- 9) RAMP to 0 PSI in 10 sec

Change Variable

Sets the value of an internal variable of the ER5000, selected from the Variable drop-down list, to the value entered in the Value entry field.

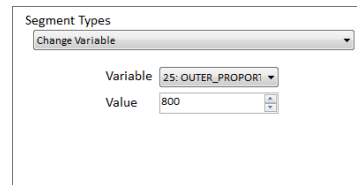

The screenshot shows a "Change Variable" configuration window. It features a dropdown menu labeled "Segment Types" with "Change Variable" selected. Below this are two fields: "Variable" with a dropdown menu showing "25: OUTER_PROPOR1" and "Value" with a text input field containing "800".

Refer to the [Internal Variables](#) section for a table listing all of the ER5000's internal variables, as well as detailed information about the settings for the most commonly used variables.

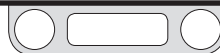

ER5000 — The ERTune™ Program: Basic Features

Additional Commands Available for “F” Model ER5000s

Soak

Pauses the Profile while the ER5000 responds to a step setpoint change, then dwells at that setpoint for a specified amount of time. The Error Band (psig) field sets the range (+/-) around the setpoint. When feedback falls within this range, the ER5000 maintains the new setpoint for the amount of time, in seconds, entered in the Time to Soak (sec) entry field.

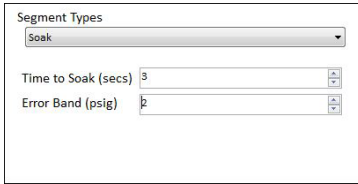

The screenshot shows a configuration window for the 'Soak' command. At the top, a dropdown menu is set to 'Soak'. Below it, there are three input fields: 'Time to Soak (secs)' with the value '3', 'Error Band (psig)' with the value '0', and a third field with a value of '0'. Each field has a small up/down arrow icon to its right.

NOTE The Dwell command counts off the specified time regardless of ER5000 response. The Soak command accounts for rise and settling time before counting off the specified time.

If

Allows the Profile to respond to the current state of the system. Checks whether a parameter of the current system status matches the condition specified in the Condition, Operator and Value fields.

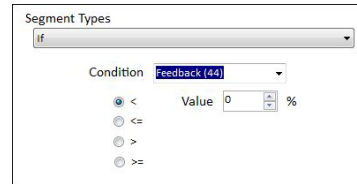

The screenshot shows a configuration window for the 'If' command. At the top, a dropdown menu is set to 'If'. Below it, there is a 'Condition' dropdown menu set to 'Feedback (44)'. To the right of the condition is a 'Value' field with the value '0' and a percentage sign. Below the condition and value fields are five radio button options for operators: '<', '<=', '>', and '>='.

- If the condition is TRUE, the next command in the Profile is executed.
- If the condition is FALSE, the next command is skipped.

NOTE To execute a multi-line command sequence based on the same condition, use the If command together with the Goto command, which is described on the next page.

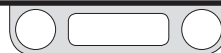

ER5000 — The ERTune™ Program: Basic Features

Goto

Moves the Profile to the command segment entered in the Go to Segment entry field.

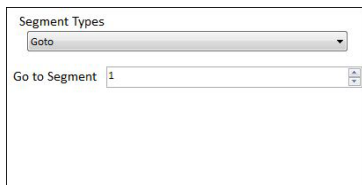

A screenshot of a software interface for configuring a Goto command. It features a dropdown menu labeled "Segment Types" with "Goto" selected. Below it is a text input field labeled "Go to Segment" containing the number "1".

NOTE To execute a multi-line command sequence based on the same condition, use the Goto command together with the If command, which is described on the previous page.

In the Profile shown to the right, the If and Goto commands are used to break the loop and end the session.

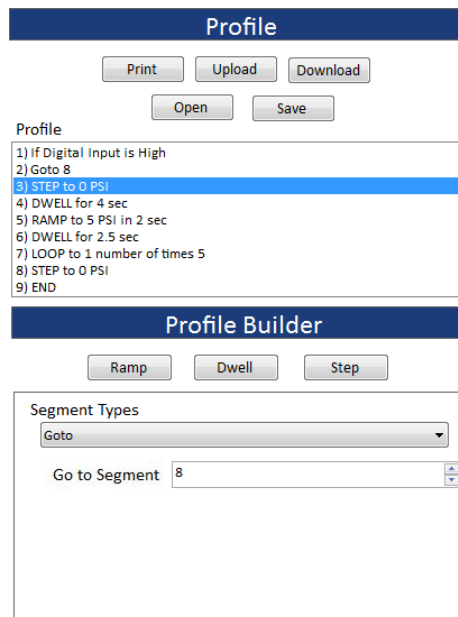

A screenshot of the "Profile Builder" software interface. At the top is a dark blue header with the word "Profile" in white. Below the header are buttons for "Print", "Upload", "Download", "Open", and "Save". The main area is titled "Profile" and contains a list of commands:

- 1) If Digital Input is High
- 2) Goto 8
- 3) STEP to 0 PSI
- 4) DWELL for 4 sec
- 5) RAMP to 5 PSI in 2 sec
- 6) DWELL for 2.5 sec
- 7) LOOP to 1 number of times 5
- 8) STEP to 0 PSI
- 9) END

The "Goto 8" command is highlighted in blue. Below the list is another dark blue header with the words "Profile Builder" in white. Underneath are buttons for "Ramp", "Dwell", and "Step". The bottom section is titled "Segment Types" and contains a dropdown menu with "Goto" selected and a text input field labeled "Go to Segment" containing the number "8".



ER5000 — The ERTune™ Program: Basic Features

Digital Output (ER Outputs are Ports 3 & 4)

Sends a signal to trigger a process in another part of the system. Refer to the Digital Outputs wiring configuration for an example of an ER5000 with digital outputs.

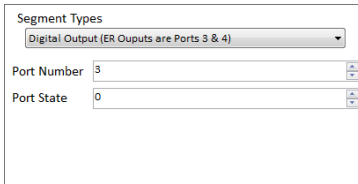

Segment Types	
Digital Output (ER Outputs are Ports 3 & 4)	
Port Number	3
Port State	0

Enter the ER5000 port number for the digital output in the Port Number field and the ER5000 port state (0 => open circuit, 1=> closed circuit) in the Port State entry field.

Digital Input (ER Input is Port 3)

Pauses the Profile until the specified input is set to the specified state. Refer to the Profile with External Control/Digital Inputs wiring configuration for an example of an ER5000 with digital inputs.

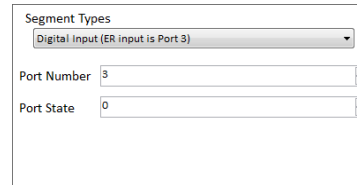

Segment Types	
Digital Input (ER Input is Port 3)	
Port Number	3
Port State	0

Enter the ER5000 port number for the digital input in the Port Number field and the ER5000 port state (0 => open circuit, 1=> closed circuit) in the Port State entry field.



ER5000 — The ERTune™ Program: Basic Features

The Data Tab

The ER5000 can save data acquired during tuning sessions, as well as during normal operations after a triggering event has taken place. Data is written to a delimited text file that is saved to your computer and uses the .dat file extension.

You can open previously acquired data files in the Plot Screen to review previous tuning sessions or monitor system performance. The saved .dat file can also be opened in a text editor or imported into a spreadsheet or database.

The ER5000 automatically adds a header to the file that includes date, time, sample rate and collection time.

The default variables that are collected are setpoint and feedback. Using controls in The Plot Screen Variable Controls and The Power User Tab, you can add up to four additional variables to data acquisition, as described on the next page.

The screenshot displays the 'Data' tab interface of the ER5000 software. It is divided into three main sections: Acquisition, Output, and Triggers.

- Acquisition:** Features a 'Sample Rate' of 0.1 Seconds/Sample and a 'Collection Time' of 60 sec.
- Output:** Shows the 'Output File' as 'datafile' with a 'Browse' button. It includes a 'Delimiter' set to 'Space' and a 'Data Acq Start' section with fields for 'Date' and 'Time'. A 'DAQ Comment Block' text area is also present, along with 'Plot File' and 'Start DAQ' buttons.
- Triggers:** Lists 'Trigger Events' with checkboxes and comparison options:
 - Internal Pressure: Disabled, Less than Disabled, Greater than Disabled, psig
 - Pressure (FB): Disabled, Less than Disabled, Greater than Disabled, %
 - Error (SP-FB): Disabled, Less than Disabled, Greater than Disabled, %
 - Digital Input: Radio buttons for Low and High



ER5000 — The ERTune™ Program: Basic Features

To add a variable using the Plot Screen Variable Controls

1. Click the Add Variable button.
2. A new line is added under Variable Name.
3. Click the Down Arrow (▼) to open the drop-down list.

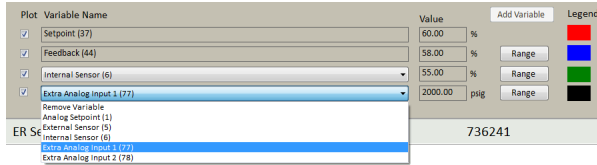

4. Select the input source you wish to track.
5. Click the Plot check box to the left of the drop-down list to add the variable to data acquisition.

IMPORTANT! Data will not be collected for this variable unless the Plot check box is checked.

NOTE This will also add the variable to the Plot Screen display.

NOTE You may repeat this process to add a second additional variable.

To set or change the range for an added variable

IMPORTANT! Changes made using the Range buttons in the Plot Screen Variable Controls change the actual range of values tracked by the ERTune™ program. Be sure the values you enter are correct for your application so that the values the program tracks are an accurate representation of system conditions.

1. Click the Range button to the right of drop-down list. The Define Variable Range window opens.

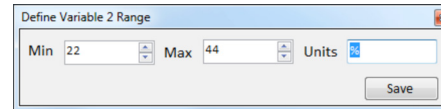

NOTE The window will be labeled as Variable 1 or Variable 2, depending on which added variable range is being defined.

2. Enter values for minimum, maximum and/or units of measure.
3. Click Save.

To add a variable using the Power User Tab

1. Select Help -> Power User to display The Power User Tab.
2. Click the tab to make it active.
3. In The Read/Write Panel, select a variable from the Read/Write Variable drop-down list.
4. Click the Add to DAQ check box.



ER5000 — The ERTune™ Program: Basic Features

The Acquisition Panel

The entry fields in this panel allow you to set the sample rate and collection time for the data file.

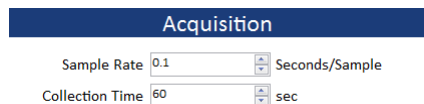

The screenshot shows a dark blue header with the word "Acquisition" in white. Below the header are two input fields. The first is labeled "Sample Rate" and contains the value "0.1", with the unit "Seconds/Sample" to its right. The second is labeled "Collection Time" and contains the value "60", with the unit "sec" to its right. Both fields have small up/down arrows on their right sides.

The Sample Rate entry field accepts any multiple of 0.1 seconds.

NOTE While the minimum sample rate the ERTune™ program can process is 0.1 seconds, your actual sampling rate may be limited by the processing power of the PC that is running the program.

The Collection Time entry field sets the default timeframe for data collection. The maximum value you can enter is 31,536,000 seconds, which is 1 year.

To control data collection manually

1. Enter a value in the Collection Time entry field that is considerably higher than your intended collection time. This will prevent the program from automatically terminating data collection prematurely.
2. Click the Start DAQ button. The button changes to display Stop DAQ and data acquisition begins.
3. Click the button again when you wish to end collection. The button returns to a display of Start DAQ and the data file is saved to the PC.

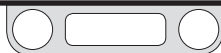

ER5000 — The ERTune™ Program: Basic Features

The Output Panel

The entry fields in the Output Panel set the parameters of the .dat file.

Output Panel interface showing fields for Output File (datafile), Delimiter (Space), Data Acq Start (Date, Time), DAQ Comment Block, and buttons for Plot File and Start DAQ.

IMPORTANT! Enter the file name, data delimiter and comment block before you begin data collection. The data file is saved automatically when the Collection Time ends.

Output File

The Output File entry field sets the file name of the data file. The extension is appended automatically.

Browse Button

The Browse button opens a Windows Explorer window to select the folder where the data file will be stored. You can also change the file name here.

Delimiter

The Delimiter drop-down list sets the delimiter that separates the data columns in the file. Select **Space**, **Comma** or **Tab**.

DAQ Comment Block

Add comments in this entry field. They will be added to the header of the data file.

Plot File Button

The Plot File button allows you to retrieve a previously stored data file and display it on the Plot Screen, as described in To view an acquired data file.

Start DAQ Button

The Start DAQ button starts data acquisition.



ER5000 — The ERTune™ Program: Basic Features

Collecting and Reviewing Data

IMPORTANT! Enter the file name, data delimiter and comment block before you begin data collection. The data file is saved automatically when the Collection Time ends.

CAUTION

If you have previously saved .dat files and do not wish to overwrite them, check that the file name and/or folder location is different from the previously saved files.

If you click the Start DAQ button when the file name and folder location matches the name and location of a previously saved file, the Overwrite window opens to warn you.

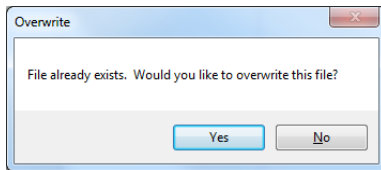

Click the Yes button to proceed with the data acquisition and overwrite the previously saved file.

Click the No button to cancel the acquisition so that you can change the file name and/or folder location of the new file.

To start data collection

1. Click the Start DAQ button. The button changes to display Stop DAQ.
NOTE The Plot Screen does not have to be active for data to be collected.

To stop data collection

1. Allow the specified Collection Time to elapse.
OR
Click the Stop DAQ button at any time.
2. The data file is automatically saved to the folder you have specified.

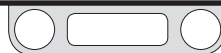

ER5000 — The ERTune™ Program: Basic Features

To view an acquired data file

1. Click the Plot File button. A Windows Explorer window opens.
2. Navigate to the .dat file you wish to view and double-click it or click the OPEN button.
3. The data file opens in the Plot Screen window.

The file opens as a single, static image of the complete data set. You can use the mouse techniques described in [Resizing the Range Displayed by the Plot Screen Using the Mouse](#) to view different sections of the data at close range.

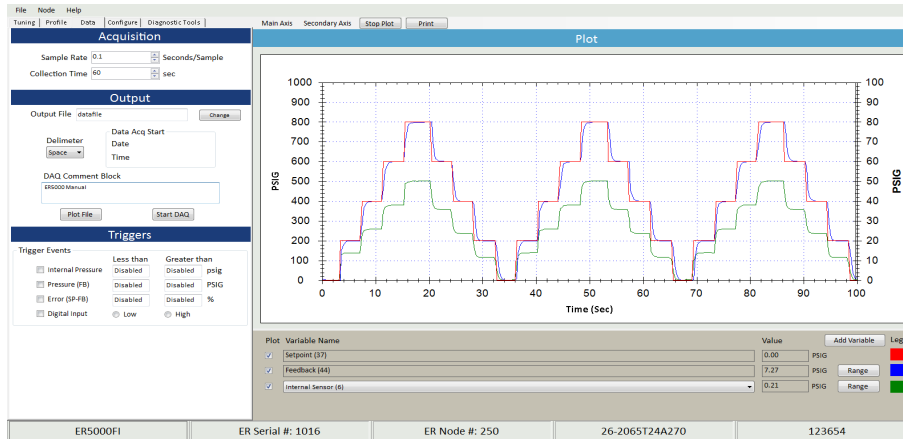

Figure 62: An Acquired Data File Opened in the Plot Screen

ER5000 — The ERTune™ Program: Basic Features

The Triggers Panel

Data acquisition can also be triggered automatically by events that happen during normal system operation. The fields in this panel allow you to select from a number of input sources for the ER5000 to monitor and to set minimum and/or maximum value triggers to initiate data acquisition.

Trigger Events	Less than	Greater than
<input type="checkbox"/> Internal Pressure	Disabled	Disabled psig
<input type="checkbox"/> Pressure (FB)	Disabled	Disabled %
<input type="checkbox"/> Error (SP-FB)	Disabled	Disabled %
<input type="checkbox"/> Digital Input	<input type="radio"/> Low	<input type="radio"/> High

⚠ CAUTION

You must enter a value that is within the limits for the input source you choose to complete the activation of the trigger. The limits are:

Internal Pressure: 0 – 100 psig

Pressure (FB): -12.12% – 111.97%

Error (SP-FB): 0.00% – 100%

If you enter a value below the Less than (minimum) or above the Greater Than (maximum), the trigger will revert to Disabled.

Be aware that the display will not revert until you leave the Data Tab.

To collect data based on a triggered event

1. In the Triggers Panel, click the check box next to the input source or sources you wish to track.

IMPORTANT! You must click the check box to activate the input source. The entry fields will accept entries when the box is unchecked, but will revert to **Disabled** when you leave the Data Tab.

2. Set a Less than (minimum) value and/or Greater than (maximum) value that will trigger an event.

IMPORTANT! When you click in an entry field, the limit is displayed as the default value. You must change this value or the field will revert to **Disabled** when you click out of it.

NOTE You may select any or all of the sources and set minimum and/or maximum values for each. Data collection will begin when any of the triggering values is reached.

To activate data collection based on a triggered event

1. Check that you have selected all events and set all values that you wish to act as triggers for data collection.
2. Enter a value in the Collection Time entry field that is considerably higher than your intended collection time. This will prevent the program from automatically terminating data collection prematurely.

(continued next page)

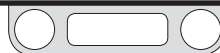

ER5000 — The ERTune™ Program: Basic Features

3. Click the Start DAQ button. Triggering is activated and the button changes to display Stop DAQ.
4. When any of the triggering conditions is met, data acquisition will begin. The program alerts you that acquisition has been activated with a message in the Menu Bar.

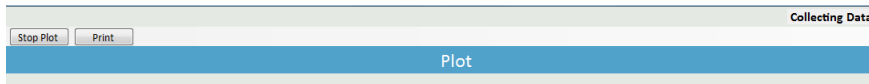

To deactivate data collection based on a triggered event

1. Click the Stop DAQ button.

To remove a triggered event from data collection

1. In the Triggers Panel, uncheck the box next to the input source you no longer wish to track.

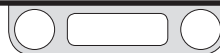

ER5000 — The ERTune™ Program: Basic Features

The Configure Tab

The entry fields and list fields in this tab allow you to modify the system configurations of the ER5000 to match the requirements of your application.

WARNING

Most controls in the ERTune™ program operate in real time and have an immediate effect on system performance. Be aware of system limitations before you change the settings of a control. Depending on the application, these changes may upset the process control, which may result in personal injury or property damage.

 **NOTE** Be aware of the operational and mechanical limitations of your system when using the fields in this tab. The fields have real-time control over the ER5000.

 **NOTE** After you enter a new value in an entry field, press the Tab key to download the new value to the controller.

 **NOTE** Selections made from drop-down lists become active as soon as the mouse button is released.

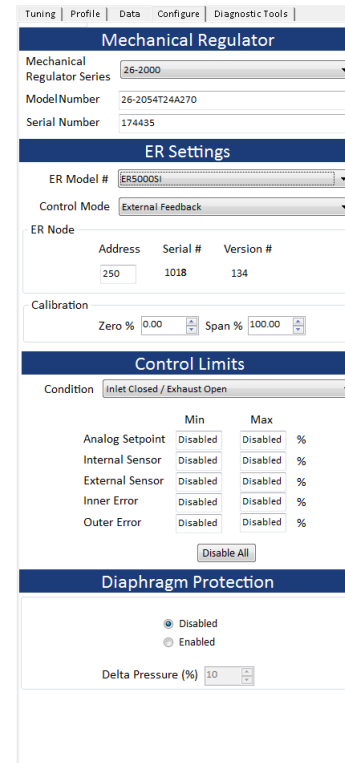

The screenshot shows the 'Configure' tab of the ER5000 interface. It is divided into several sections:

- Mechanical Regulator:** Includes dropdown for 'Mechanical Regulator Series' (26-2000), and input fields for 'Model Number' (26-2054724A270) and 'Serial Number' (174435).
- ER Settings:** Includes dropdown for 'ER Model #' (ER5000SI) and dropdown for 'Control Mode' (External Feedback). Below is an 'ER Node' table:

Address	Serial #	Version #
250	1018	134
- Calibration:** Includes input fields for 'Zero %' (0.00) and 'Span %' (100.00).
- Control Limits:** Includes a dropdown for 'Condition' (Inlet Closed / Exhaust Open) and a table of control limits:

	Min	Max	
Analog Setpoint	Disabled	Disabled	%
Internal Sensor	Disabled	Disabled	%
External Sensor	Disabled	Disabled	%
Inner Error	Disabled	Disabled	%
Outer Error	Disabled	Disabled	%

A 'Disable All' button is located below the table.
- Diaphragm Protection:** Includes radio buttons for 'Disabled' (selected) and 'Enabled', and an input field for 'Delta Pressure (%)' (10).



ER5000 — The ERTune™ Program: Basic Features

The Mechanical Regulator Panel

The fields in this panel display the series number, model number and serial number for the regulator that the ER5000 controls. You enter this information during setup.

Mechanical Regulator	
Mechanical Regulator Series	26-2000
Model Number	26-2054T24A270
Serial Number	174435

If you change regulators, you can update the information here.

To change the Regulator Series

1. Click the Down Arrow (▼) of the Mechanical Regulator Series drop-down list.
2. Select a different TESCOM™ series number or, if appropriate, select **Other** or **None**.

NOTE The ERTune™ program automatically checks for PIDs included with the software that are optimized for the Regulator Series you have selected. If you click the Yes button, the new settings will be downloaded to the ER5000. If you click the No button, the current settings will be used.

To change the regulator model number or serial number

1. Enter a new value in the Model Number or Serial Number entry field and press the Tab key.

The ER Settings Panel

The fields in this panel control the basic configuration of the ER5000.

ER Settings			
ER Model #	ER5000S1		
Control Mode	External Feedback		
ER Node			
Address	Serial #	Version #	
250	1018	134	
Calibration			
Zero %	0.00	Span %	100.00

ER Model

This drop-down list allows you to change the model number of the ER5000.

Control Mode

This drop-down list allows you to change the feedback source (Control Mode) for the ER5000.

To change the Control Mode of the ER5000

1. Click the Down Arrow (▼) of the Control Mode drop-down list. Select **Internal Feedback**, **External Feedback** or **Cascade**.

NOTE You may need to tune the ER5000 after changing the Control Mode. Refer to The Tuning Tab: Controls and Functions for Tuning the ER5000 for procedures and tips for tuning the ER5000.

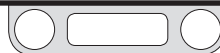

ER5000 — The ERTune™ Program: Basic Features

ER Node

This entry field allows you to change the Node Address of the ER5000.

To change the Node Address of the ER5000

1. Enter a new value in the Address entry field and press the Tab key.

NOTE The maximum value that can be used for a Node Address is 250. Any value higher than 250 that is entered in this field will be truncated to the first two digits.

2. The Comm Error Window opens and the ER5000 scans through the Node Addresses until it reaches the new address you have entered. The window then closes and the new node address is registered.

NOTE The Serial Number of the ER Series controller cannot be changed from the Configure tab.

NOTE The Version Number refers to the current version of the ER5000 internal software. It cannot be changed.

Calibration

These entry fields allow for fine adjustment of the ER5000. The defaults meet the needs of most applications. However, your application may require an adjustment of these values to compensate for external transducers which require calibration, such as a transducer that has been over pressurized.

To change the calibration of the ER5000

1. Enter a new value in the Zero % and/or Span % entry fields and press the Tab key.



ER5000 — The ERTune™ Program: Basic Features

The Control Limits Panel

The entry fields in this panel allow you to set system Control Limits which the ER5000 will then monitor.

	Min	Max	
Analog Setpoint	Disabled	Disabled	%
Internal Sensor	Disabled	Disabled	%
External Sensor	Disabled	Disabled	%
Inner Error	Disabled	Disabled	%
Outer Error	Disabled	Disabled	%

Disable All

The ER5000, in addition to its control function, can also be configured to monitor when operational or mechanical limits of the system have been exceeded. When the controller detects a signal that exceeds a set limit, it activates the internal solenoid valves to reach one of three Control Limit Conditions:

- Inlet Closed/Exhaust Closed
- Inlet Closed/Exhaust Open
- Inlet Open/Exhaust Closed

The Control Limit Conditions provide added security in the event of a system failure such as broken transducer wiring, lack of supply pressure or pipe ruptures.

The default Condition is Inlet Closed/Exhaust Open, which ensures that a pressure reducing system will be vented if a limit is exceeded. If your application uses a non-venting regulator, refer to A Note Concerning Non-Venting Regulators in Closed Loop Applications if you intend to use the ER5000 in this condition.

CAUTION

The Control Limits feature provides an additional level of system monitoring. Activation indicates a potential problem, but will not, by itself, prevent problems from occurring. It should not be considered to be a safety mechanism, nor is it intended to be a safety feature or pressure limiting device.

The entry fields in this panel allow you to monitor any or all of five ER5000 internal variables and to set minimum and/or maximum limits to be tracked for each source. If multiple variables are selected the ER5000 will respond when any of the assigned sources exceeds the set limit.

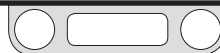

ER5000 — The ERTune™ Program: Basic Features

To add a Control Limit for the ER5000 to monitor

1. Enter a value in the Min or Max entry field of the variable that you wish to monitor and press the Tab key.

CAUTION

You must enter a value that is within the limits for the variable you choose in order to activate it as a Control Limit.

The limits are:

Analog Setpoint: -12.12% – 111.97%

Internal Sensor: -12.12% – 111.97%

External Sensor: -12.12% – 111.97%

Internal Sensor: -12.12% – 111.97%

Inner Error: -124.08% – 124.08%

Outer Error: -124.08% – 124.08%

If you enter a value below the Min or above the Max limit, the field will immediately revert to the default value and will revert to **Disabled** when you click out of the field.

2. To monitor for both minimum and maximum limits, enter values in both fields.

 **IMPORTANT!** When you click in an entry field, the limit is displayed as the default value. You must change this value or the field will revert to **Disabled** when you click out of it.

To remove a Control Limit

1. Enter a value that is beyond the limit for that field. It will revert to **Disabled** when you click out of the field.

To remove all Control Limits

1. Click the Disable All button.

To change the Control Limit Condition

1. Select a different condition from the drop-down list.

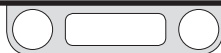

ER5000 — The ERTune™ Program: Basic Features

The Diaphragm Protection Panel

The entry fields in this panel allow you to enable Diaphragm Protection for the connected regulator.

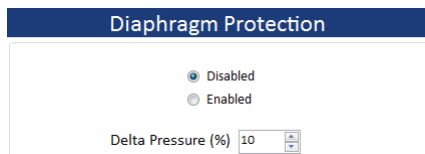

Non-venting regulators, which do not feature a regulator vent to exhaust excess system pressure, pose a particular challenge in closed loop applications when the downstream flow is blocked.

Regulator Diaphragm Protection is designed for applications that use a non-venting regulator in a system that does not have continuous flow. It is most beneficial for this type of application when the regulator is a metal diaphragm sensed regulator. For more information on this feature, refer to [A Note Concerning Non-Venting Regulators in Closed Loop Applications](#).

You should consider using this feature if your application meets **one or both** of these conditions:

- The regulator you will be using is a non-venting, metal diaphragm sensed regulator.
- The regulator you will be using is non-venting and the application is not continuous flow.

CAUTION

Regulator Diaphragm Protection is not recommended for applications which do not meet one or both of these conditions.

To activate Regulator Diaphragm Protection

1. Click the Enable radio button.
2. Enter a value in the Delta Pressure (%) entry field.

The value you enter in the Delta Pressure (%) entry field sets the maximum difference between the setpoint and the dome pressure of the regulator to which the ER5000 will respond, expressed as a percentage of the Sensor Range you set in Step 7.

When Delta Pressure exceeds the value entered in this field, the ER5000 stops responding to error. This prevents the high differential pressure situations and delayed response described in [A Note Concerning Non-Venting Regulators in Closed Loop Applications](#).

To deactivate Regulator Diaphragm Protection

1. Click the Disabled radio button.



ER5000 — The ERTune™ Program: Basic Features

The Diagnostic Tools Tab

The buttons on this panel open troubleshooting tools and additional reference files for the ER5000.

The System Check Panel

The Open button in this panel opens a presentation that offers additional information and tips on checking operational parameters for the ER5000.

The ER Solenoid Leak Test Panel

The Start button in this panel initiates a solenoid valve leak test.

⚠ CAUTION

This procedure will hold the ER5000 Inlet Valve open, resulting in full inlet pressure at the ER5000 Outlet Port. The test should be performed with the Outlet Port plugged and isolated from the regulator. If it is not possible to isolate the Outlet Port of the ER5000, take steps to prevent system overpressurization.

To perform a solenoid valve leak test

1. Click the Start button. The first screen opens.

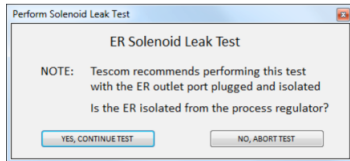

(continued next page)

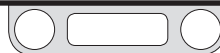
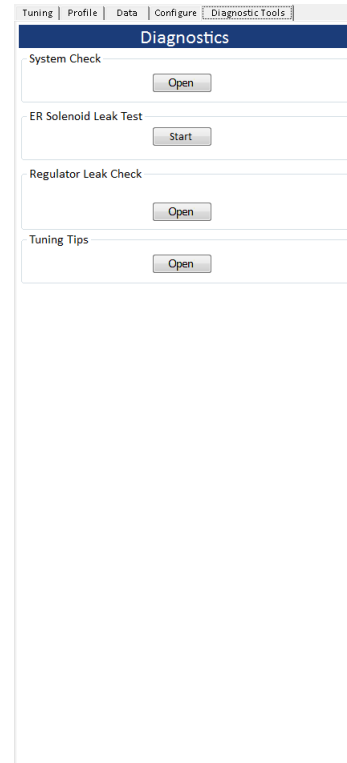

ER5000 — The ERTune™ Program: Basic Features

- To continue to the test, click the YES, CONTINUE TEST button. To abort the test so you can institute safety procedures, click the NO, ABORT TEST button.
- The second screen opens. This is an additional caution screen.

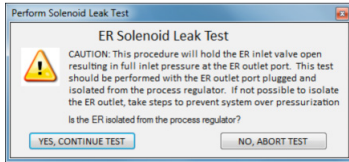

- To continue to the test, click the YES, CONTINUE TEST button. To abort the test so you can institute safety procedures, click the NO, ABORT TEST button.
- The third screen opens. Verify that the Outlet Port of the ER5000 is plugged and a minimum of 100 psig / 6.9 bar inlet pressure is being applied to the Inlet Port of the controller.

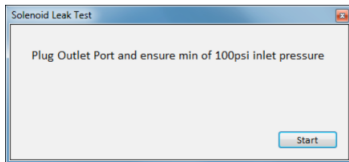

- Click the Start button to start the test.

- The test begins. The program first tests the Inlet Valve.

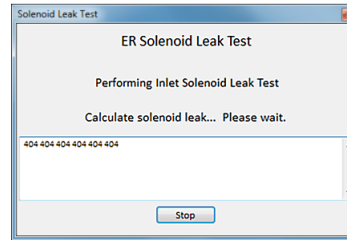

- The program then tests the Outlet (Exhaust) Valve.

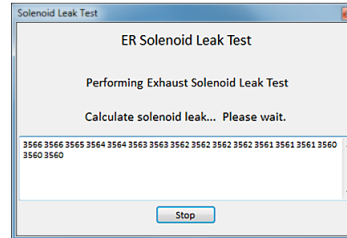

The Solenoid Leak Test reads variable #44 (ID_FEEDBACK), which during the test is the feedback from the ER5000's 0–100 psig / 0–6.9 bar internal sensor. The feedback is measured in “counts,” which are units of 0.03 psig / 0.002 bar between a minimum value of 400 (0%) and a maximum value of 3700 (100%).

(continued next page)



ER5000 — The ERTune™ Program: Basic Features

For the Inlet Valve test, the controller exhausts all internal pressure to start with a reading of 400 (the initial value for your controller may vary slightly from 400) and monitors feedback for 30 seconds. If the reading rises by more than 10 counts from the initial value during the test period, that means that the Inlet Valve has allowed in more than 0.3 psig / 0.02 bar of pressure, which is considered an Inlet Valve failure.

For the Outlet Valve test, the controller opens the Inlet Valve and lets in pressure up to the maximum reading of 3700 counts (again, the initial value for your controller may vary slightly from 3700). If the reading falls by more than 10 counts over the next 30 seconds, that means more than 0.3 psig / 0.02 bar of pressure has escaped, which is considered an Outlet Valve failure.

9. The program returns the results.

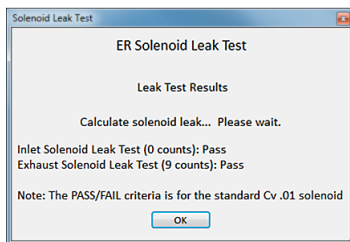

NOTE If the ER5000 is connected to a regulator when the Solenoid Leak Test is run and a failure is recorded, it may indicate a leak in the regulator or the adaptor fitting. The test should be re-run with the ER5000 isolated from the regulator and the Outlet Port plugged.

The Regulator Leak Check Panel

The Open button in this panel opens a presentation that takes you through a step-by-step process to test a typical mechanical regulator for pressure leaks.

The Tuning Tips Panel

The Open button in this panel opens a presentation that offers additional information and tips for tuning the ER5000.

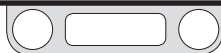



THE ERTUNE™ PROGRAM: POWER USER



ER5000 — The ERTune™ Program: Power User

The Power User Tab

This tab gives you access to advanced configuration options. Most applications of the ER5000 do not require access to this tab.

NOTE The entry fields in this tab control the basic operational parameters of the ER5000. The default values should not be changed if you are not certain how this will effect the performance of the controller.

To display the Power User Tab

1. Select Help -> Power User. The Power User Tab appears to the right of the Diagnostic Tools Tab.
2. Click the Power User Tab to make it active.

NOTE On most screens, you will need to scroll to reach all of the panels in the Power User Tab.

The screenshot displays the 'Power User' tab interface with the following sections:

- Additional ER Settings**
 - External Feedback Source: External Feedback, Extra Input #1
 - Setpoint to 0 on Power Up: Enable, Disable
- Read/Write**
 - Read/Write Variable: 88
 - Add to DAQ:
 - Mode: Read, Write
 - Raw: 0, Signed:
- Read/Write**
 - Read/Write Variable: 89
 - Add to DAQ:
 - Mode: Read, Write
 - Raw: 0, Signed:
- Solenoid Settings**

Minimum Pulse Width	Factory
Inlet: 10	10
Exhaust: 10	10

Normal Reverse
- Algorithm Update Rate**

25 ms
- Pulse Mode**

Disable Enable

Period: 3
Width: 8
Deadband: 1

Note: 'Integral Deadband' must be greater than zero for pulsing to function.
- Password**

Disable Enable

Change

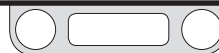

ER5000 — The ERTune™ Program: Power User

The Additional ER Settings Panel

External Feedback Source

This field controls which feedback source displays in the Plot Screen when you have wired the ER5000 for multiple feedback sources. Refer to [Switch Feedback Control to a Second Feedback Source](#) for an example of this wiring configuration.

The screenshot shows a control panel titled "Additional ER Settings". It contains two sections. The first section, "External Feedback Source", has two radio buttons: "External Feedback" (which is selected) and "Extra Input #1". The second section, "Setpoint to 0 on Power Up", has two radio buttons: "Enable" and "Disable" (which is selected).

- External Feedback is the transducer connected to the ER5000 through the orange wire (J3 Pin 3).
- Extra Input #1 is the transducer connected to the ER5000 through the brown/white wire (J4 Pin 1).

To switch the external feedback source

1. Click the radio button next the source you wish to track.

IMPORTANT! Refer to the steps [To change the display of the main \(left\) axis to the new range after you change the feedback source](#), to be sure the ERTune™ program is tracking the correct range of values for the new source.

Setpoint to 0 on Power Up

The ER5000 stores the last registered setpoint when it powers down and powers up at the setpoint stored in internal memory. Some applications may require a zero-pressure startup. This field allows you to set that default for the controller.

To enable Setpoint to 0 on Power Up

1. Click the Enable radio button.



ER5000 — The ERTune™ Program: Power User

The Read/Write Panel

The entry fields in this panel allow you to monitor and modify the internal variables of the ER5000. Refer to the [Internal Variables](#) section for a complete list of the ER5000's internal variables, as well as descriptions of the most commonly used variables.

Read/Write

Variable: 88:DIGITAL_OUTPUT1 88

Add to DAQ Read Write

Raw: 0 Signed

Read/Write

Variable: 89:DIGITAL_OUTPUT2 89

Add to DAQ Read Write

Raw: 0 Signed

NOTE There are two read/write windows in the panel. Each includes an Add to DAQ check box. When this box is checked, the variable in the window is added to data files acquired during this session. This allows you to add up to two additional variables to your data acquisition.

To check the value of an Internal Variable

1. Click the Down Arrow (▼) to open the Variable drop-down list.

2. Select from the list of variables.
3. The Variable ID number displays to the right of the list. The variable value displays in the Raw entry field. The list to the right indicates whether it is a signed or an unsigned value.

NOTE Values are grayed out when Read is checked.

To modify the value of an Internal Variable

1. Click the Write radio button. The entry fields become active.
2. Enter a new value and press the Tab key.
3. To switch between signed and unsigned value, select from the Signed drop-down list.

NOTE The internal variables control the basic operational parameters of the ER5000. The default values should not be changed if you are not certain how this will effect the performance of the controller.

Variables listed as READ ONLY cannot be changed from within the ERTune™ program.

To add a variable to data acquisition

1. Click the Add to DAQ check box.

To remove a variable from data acquisition

1. Uncheck the Add to DAQ check box.

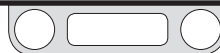

ER5000 — The ERTune™ Program: Power User

The Solenoid Settings Panel

The entry fields in this panel allow you to change the minimum pulse width for the inlet and exhaust solenoid valves in the ER5000. This setting changes the responsiveness of the controller.

Solenoid Settings		
	Minimum Pulse Width	Factory
Inlet	<input type="text" value="10"/>	10
Exhaust	<input type="text" value="10"/>	10
<input checked="" type="radio"/> Normal <input type="radio"/> Reverse		

Minimum Pulse Width

These entry fields set the minimum value of the pulse width for the Inlet and Exhaust Valves. Factory defaults are displayed to the right.

Increasing the value in the Minimum Pulse Width field increases the baseline (non-activated) pulse width being sent to the valves. This results in a lower threshold of activation when an error is generated and an increase in the responsiveness of the ER5000.

⚠ CAUTION

Setting the minimum pulse width too high can cause the ER5000 to activate in response to transient errors which do not require correction. Setting it too low may delay response to error.

⚠ CAUTION

These settings have an immediate and profound effect on the performance of the ER5000. The default settings are optimal for most applications and should not be changed if you are not certain how this will effect the performance of the controller.

⚠ CAUTION

It is strongly recommended that changes to the default values be made incrementally, by a value of 1 and that performance be monitored once the change is in effect.

Normal/Reverse

This field allows you to reverse the normal response of the ER5000, with the exhaust opening instead of the inlet and vice versa.

This allows you to configure the ER5000 for use in applications such as regulating cooling air for temperature, where increasing flow reduces the temperature (feedback).

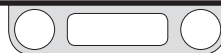

ER5000 — The ERTune™ Program: Power User

The Algorithm Update Rate Panel

This field allows you to change the rate at which the ER5000 operates.

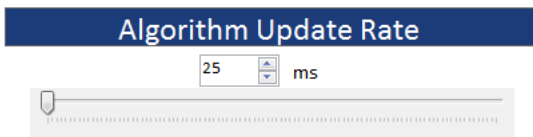

By default, the ER5000 monitors feedback and generates a response every 25 ms. Some applications provide feedback at a considerably slower rate and may see a performance improvement if the Algorithm Update Rate is set higher, which slows the response of the ER5000.

To change the Algorithm Update Rate

1. Move the slider control to the right or enter a multiple of 25 ms in the entry field, to increase the rate.

NOTE The default rate is 25 ms, which is also the minimum value the field will accept. Changes to this field must be made in increments of 25 ms.

CAUTION

The Algorithm Update Rate controls the speed of response of the ER5000. The default values should not be changed if you are not certain how this will effect the performance of the controller.



ER5000 — The ERTune™ Program: Power User

The Pulse Mode Panel

The fields in this panel give you precise control over how the ER5000 responds to errors which fall within the deadband set by the Integral Limits - Deadband controller. Refer to The Tuning Tab: Controls and Functions for Tuning the ER5000 for more information on the PID controllers.

Pulse Mode

Disable Enable

Period

Width

Deadband

Note: 'Integral Deadband' must be greater than zero for pulsing to function.

NOTE The Integral Deadband must be set to a value greater than zero for Pulse Mode to function.

The purpose of Integral Deadband is to prevent small, transient errors from “charging up” the Integral term and inducing windup or oscillations during steady state.

Pulse mode responds to errors within the Integral Deadband range with short, pulsed, activation of the solenoid valves. These pulsed responses continue until feedback falls within the Pulse Mode Deadband range (in effect, the deadband within the deadband). When feedback falls within this inner deadband, the solenoid valves remain closed.

To enable Pulse Mode

1. Click the Enable radio button.

To disable Pulse Mode

1. Click the Disable radio button.

There are three parameters you can set for Pulse Mode.

Period

This is the number of times the ER5000 cycles through the Algorithm Update before pulsing. The default Algorithm Update rate is 25 ms.

Width

This field determines how long the solenoid valve remains open during a pulse. Increasing the value increases the level of response for each pulse.

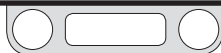

ER5000 — The ERTune™ Program: Power User

Deadband

This is the Pulse Width Deadband, the “deadband within a deadband” of the Integral Deadband. When feedback falls within this inner range, Pulse Mode stops responding.

Pulse Width Deadband is set to a much smaller level than Integral Deadband, allowing the ER5000 to respond to a very small level of error.

- Integral Deadband is generally set within a range of 0–0.5% of feedback.
- Pulse Width Deadband is set by counts of error. Each count equates to .03% of feedback. Pulse deadband is generally set at 1–3 counts, which equates to .03–.09% of feedback.

To change the Pulse Width settings

1. Enter a new value in the Period, Width or Deadband field and press the Tab key.

 **NOTE** The values should be changed incrementally until the desired response is achieved.

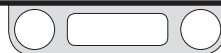

ER5000 — The ERTune™ Program: Power User

The Power User Tab: The Password Panel

The fields in this panel allow you to add password protection to the ERTune™ program. When enabled, the ERTune™ program will require the user to enter a password before it will open.

⚠ CAUTION

If you forget your password

Contact TESCO™ customer support. They will give you a password to unlock the program. You should immediately change your password, using the supplied password as your current password.

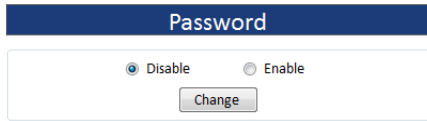

To enable password protection

1. Click the Enable radio button. The Enter Password window opens.
2. Enter the password and click the Verify button. The Validate Password window opens.

NOTE The password can be any combination of alphanumeric characters and can be of any length.

3. Re-enter the password and click the Verify button.

NOTE The passwords must match.

4. The password will become effective the next time the ERTune™ program is opened. The Enter Password window opens instead.

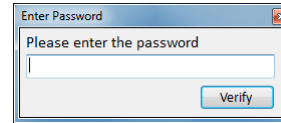

5. Enter the password and click the Verify button.

To disable password protection

1. Click the Disable radio button.

NOTE The current password is stored in memory and will become active the next time you click the Enable radio button.

To change the current password

1. Click the Change button. The Change Password window opens.
2. Enter the current password, to verify that you are authorized to change it and click the Verify button.
3. Enter the new password in the Password field.
4. Re-enter the new password in the Verify Password field and click the Change button.

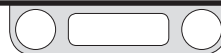



ER5000 SOFTWARE DEVELOPMENT SUPPORT



ER5000 — ER5000 Software Development Support

ER5000 Communication Requirements

The ER5000 communicates via USB or RS485.

- **USB communication** takes place via a direct connection between the Mini-B USB port on the ER5000's control board and a USB terminal on the PC. A USB cable with a Mini-B plug configured to fit inside the controller is included with your purchase. Refer to the [Getting Started](#) section for proper installation.

The driver should install during standard setup of the ERTune™ program. To install the driver manually, refer to the [Troubleshooting](#) section.

USB communication takes place through a USB cable and requires no additional wiring.

- **RS485 communication** requires a converter, which must be purchased separately. The ER5000 can communicate using a USB to RS485 converter (TESCOM model # 82948) or an RS232 to RS485 (TESCOM model # 85061) converter. RS485 must be used if your application calls for multiple controllers

and you wish to daisychain them in the same network. You can link up to 32 ER5000s in a single network.

Wiring diagrams for RS485 communication can be found in this manual beginning on [page 89](#). There are diagrams for both USB to RS485 and RS232 to RS485 converters, as well as single and multiple controller applications. Refer to the [RS485 Communication](#) section for third party converter requirements.

ER5000 Software Development Support

The ERTune™ program, which is included with your purchase, is designed to provide an effective and intuitive interface for setup and tuning of the ER5000. The software can provide setpoints during operation and includes a basic programming language for creating multi-step Profiles that guide the controller through complex setpoint sequences. Refer to [The Profile Panel](#) section for more information on this feature.



ER5000 — ER5000 Software Development Support

You can also develop your own process control software to communicate with the ER5000. Typically, programmers use the Windows-based DLL to communicate with the ER5000. A 32-bit version of the dll, along with the source code, can be found in the ER5000 Software.

Windows Programming Examples

Sample programs that illustrate the use of the ER5000 Dynamic Link Library (ER5000DLL.dll) are provided in the Resources section of the ER5000 Software in the following languages:

- LabVIEW
- VB.NET
- C
- C#

To view the sample programs

1. Download the ER5000 Software and Manual file which can be found at TESCOM.com under the “Download ER5000 Software and Manual” link. Once the file is downloaded, extract the zip file, click on the .exe file, and the ER5000 User Support Software and Manual menu will open.



2. The ER5000 User Support Software and Manual menu gives you access to the programs and reference materials. Click the **Resources** button.

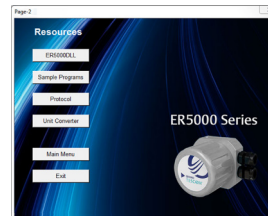

3. Click the **Sample Programs** button.
4. Click the button for the language example you wish to view.

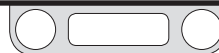

ER5000 — ER5000 Software Development Support

Accessing the Windows DLL File

The TESCOM™ protocol, ER5000DLL.dll, allows easy access to the ER5000 from a PC for Windows based programs. The protocol is available as a 32-bit DLL (Dynamic Link Library). The DLL downloads to the PC as part of the ERTune™ program installation and can also be found in the ER5000 Software.

To locate and use the Windows DLL file

1. Download the ER5000 Software and Manual file which can be found at TESCOM.com under the “Download ER5000 Software and Manual” link. Once the file is downloaded, extract the zip file, click on the .exe file, and the ER5000 User Support Software and Manual menu will open.

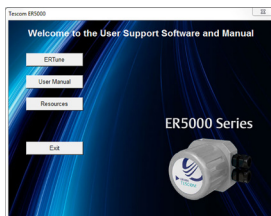

2. The ER5000 User Support Software and Manual menu gives you access to the programs and reference materials. Click the Resources button.

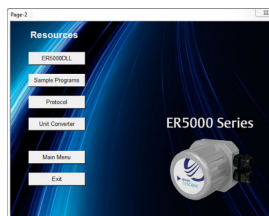

3. Click the ER5000DLL button. This opens the folder that contains the ER5000DLL.dll file. You can open the file or save it to a location that is accessible to the custom program being developed.



The TESCOM™ Protocol

Not all systems run on a Windows-compatible platform. TESCOM provides two resources for non-typical applications, which can be found in the Protocol section of the ER5000 Software:

- A written description of the software protocol, called PROTOCOL.pdf.
- The uncompiled protocol source code.

Step-by-step instructions to view the code are on the next page of this section.

Direct access to the uncompiled source code allows programmers to alter and recompile the TESCOM Protocol in a format suitable for your system.

The TESCOM protocol software includes the following six functions:

Startup

This function must be called during program initialization before any other function to allow PC initialization, including the serial port. It does not send any data to the ER5000. This function needs to be called only once.

WriteNetVar

This function is used to write to any of the ER5000 internal variables.

ReadNetVar

This function is used to read any of the ER5000 internal variables.

WriteProfileSegment

This function is used to write to any of the ER5000 Profile commands (segments). Refer to The Profile Panel section for more information on the Profile commands.

ReadProfileSegment

This function is used to read any of the ER5000 Profile commands (segments). Refer to The Profile Panel section for more information on the Profile commands.

Shutdown

This function must be called before exiting the program. It does not send any data to the ER5000. This function needs to be called only once.

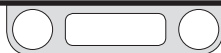

ER5000 — ER5000 Software Development Support

To view the source code of the TESCO™ protocol file

1. Download the ER5000 Software and Manual file which can be found at TESCO.com under the “Download ER5000 Software and Manual” link. Once the file is downloaded, extract the zip file, click on the .exe file, and the ER5000 User Support Software and Manual menu will open.



2. The ER5000 User Support Software and Manual menu gives you access to the programs and reference materials. Click the Resources button.



3. Click the Protocol button.

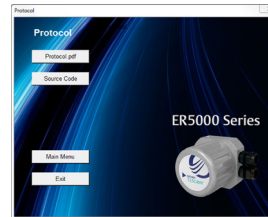

4. Click the Source Code button to directly access the code or the Protocol.pdf button to open the PDF file which describes the protocol.





TROUBLESHOOTING



ER5000 — Troubleshooting

Installation

Where to Find the ERTune™ Program Files on Your PC

The ERTune™ program creates two folders on your C: drive during installation.

On PCs running Windows 7, the program files, including the program executables, device drivers, support files and reference materials, are located at:

C: -> Program Files (x86) -> Emerson -> ERTune.

On PCs running previous versions of Windows, this is located at:

C: -> Program Files -> Emerson -> ERTune.

A separate folder is created for data files generated by the program. On PCs running Windows 7, this is located at:

C: -> Program Data -> Emerson -> ERTune.

On PCs running previous versions of Windows, this is located at:

C: -> Documents and Settings -> All Users -> Application Data -> Emerson -> ERTune.

This folder is the default location for configuration files, Profiles and data acquisition files. The Windows Navigator window will default to this folder. You may save the data files generated by your application in another location, if you prefer.

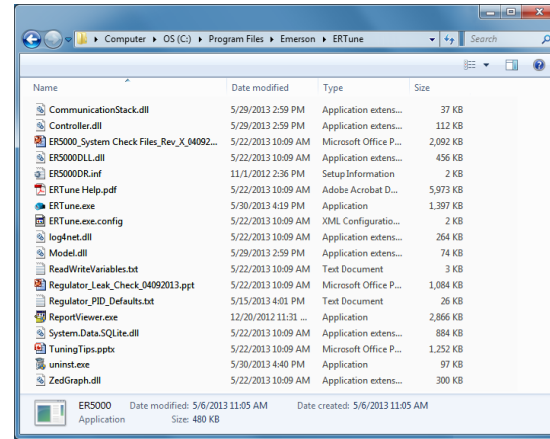

IMPORTANT! Windows 8 users: In order to maintain compatibility with previous Windows operating systems, the ERTune™ program uses the .NET Framework 3.5, which is not installed by default in Windows 8. If you are using Windows 8, you will need to download and install .NET Framework 3.5 before installing the ERTune™ program. We have provided step-by-step instructions for this task in Appendix A: Setting up the ERTune™ Program on Windows 8 PCs.

You will also need to install .NET Framework 3.5 on a PC running a previous version of Windows if the Framework has been uninstalled. The downloadable files, as well as installation instructions, can be found at: <http://www.microsoft.com/en-us/download/details.aspx?id=21>.

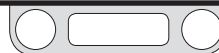

ER5000 — Troubleshooting

Installation

Installing the ER5000 USB Device Driver Manually (Windows 7)

IMPORTANT! **Windows 8 users:** You may need to disable Driver Signature Enforcement to install the ER5000 driver. We have provided step-by-step instructions for this task in Appendix A: Setting up the ERTune™ Program on Windows 8 PCs.

Some operating system configurations require that device drivers be installed manually. If the ER5000DR driver does not install automatically, follow these steps:

1. Check that the ER5000 is powered up and that both ends of the USB cable are connected. Refer to Step 5 and Step 8 of the Getting Started section for wiring the ER5000 and connecting the USB cable.
2. From the PC desktop, select:
Start -> Control Panel -> Hardware and Sound -> Device Manager.
3. Locate the ER5000 USB Serial Port in the list of devices.
4. Double-click the listing. The Properties window opens.
5. Click the Driver tab.
6. Click the Update Driver button.
7. Click the Browse my computer for driver software button.

8. Enter “C:\Program Files (x86)\Emerson\ERTune” in the Search for driver software in this location: field

OR

Click the Browse... button and navigate to the C: -> Program Files (x86) -> Emerson -> ERTune folder and click OK.

9. Click the Next button.

NOTE If your security settings caution against installing the driver, click to allow installation.

10. Installation will begin. When installation is complete, note the COM Port number for the ER5000 USB Serial Port.
11. Open the ERTune™ program. If the Comm Error window opens, check that the COM Port matches the listing in the Device Manager. If it does not, select the correct port from the drop-down list. The program should open.



ER5000 — Troubleshooting

Installation

Installing the ER5000 USB Device Driver Manually (Windows XP and earlier)

IMPORTANT! **Windows 8 users:** You may need to disable Driver Signature Enforcement to install the ER5000 driver. We have provided step-by-step instructions for this task in Appendix A: Setting up the ERTune™ Program on Windows 8 PCs.

Some operating system configurations require that device drivers be installed manually. If the ER5000DR driver does not install automatically, follow these steps:

1. Check that the ER5000 is powered up and that both ends of the USB cable are connected. Refer to Step 5 and Step 8 of the Getting Started section for wiring the ER5000 and connecting the USB cable.
2. If the driver has not been installed, the Found New Hardware Wizard window opens.
3. Click the No, not this time radio button, then click Next >.
4. In the next window, click the Install from a list or a specific location (Advanced) radio button, then click Next >.
5. In the Installation Options window, click the Search for the best driver in these locations radio button, check the Include this location in the search: check box and enter “C:\Program Files\Emerson\ERTune” in the entry field.

OR

Click the Browse... button and navigate to the C: -> Program Files -> Emerson -> ERTune folder.
Then click the Next > button.

6. The operating system will search for the device driver and install it. If the Hardware Installation Warning window opens, click the Continue Anyway button.



7. When installation is complete, a window will open informing you that the installation was successful. Click the Finish button.
8. Open the ERTune™ program. If the Comm Error window opens, check that the COM Port matches the listing in the Device Manager. If it does not, select the correct port from the drop-down list. The program should open.

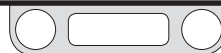

ER5000 — Troubleshooting

Operation

Checking the Configuration of the Jumpers

WARNING

⚠ The controller must be disconnected from the power supply before any additional wiring or change to jumper configuration is performed. Do not reconnect the power supply until all additional wiring connections have been made and are properly installed.

Figure 63 shows the jumpers on the ER5000.

The Voltage/Current Select Jumpers

Jumpers J5, J6, J14 and J15 are used to select between 4–20 mA and 1–5V sources for setpoint, external feedback, auxiliary input #1 and auxiliary input #2 respectively. For these jumpers, having the jumper installed (ON) configures the controller for 4–20 mA input and having the jumper not installed (OFF) configures the controller for 1–5V input.

NOTE As seen in Figure 63, 0–10V models of the ER5000 do not have these jumpers.

The Ground Filter Bypass Jumper

The recommended configuration for the Ground Filter Bypass jumper (J1) is not installed (OFF). Installing this jumper connects signal ground directly to the power supply ground.

(continued next page)

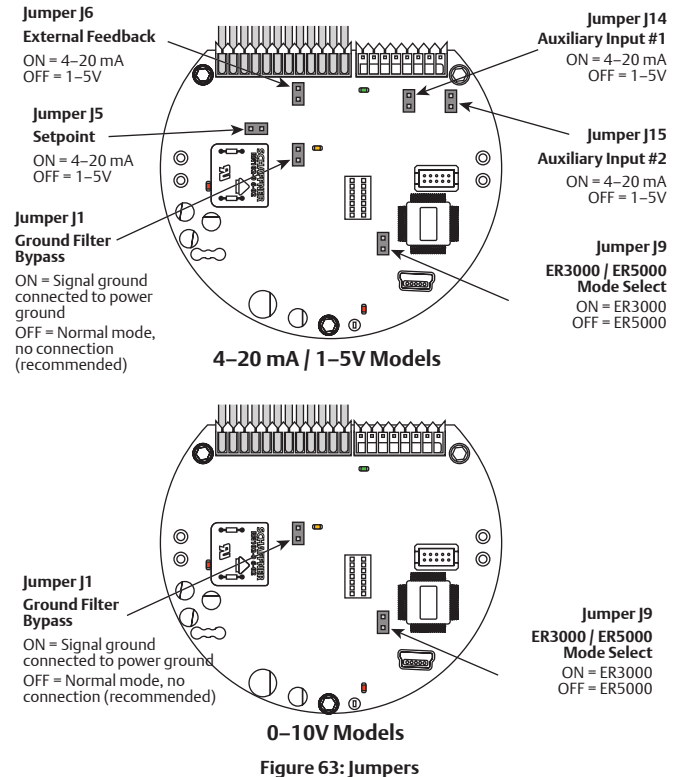

ER5000 — Troubleshooting

Operation

Checking the Configuration of the Jumpers (cont.)

While it is rare, electrical noise can at times cause a problem in an ER5000 control system. Electrical noise is defined as “unwanted, random fluctuations in an electrical signal.” It is difficult to identify sources of noise when transferring analog signals across a process plant or factory floor or in the confines of a test stand that is densely populated with various electrical, mechanical and electromechanical devices.

The ER5000 grounding system was designed to minimize noise issues by separating the signal ground from the power/board ground with a low-pass filter. However, if you are having issues with noise, installing this jumper may help.

The ER3000/ER5000 Mode Select Jumper

By default, the ER5000 uses a 16-bit A/D converter to translate analog input signals to digital. The previous model, the ER3000, used a 12-bit converter. For applications where the ER5000 will be controlled by software originally written for the ER3000, **Jumper J9** allows the ER5000 to switch from 16-bit to 12-bit A/D conversion and the application will integrate the new controller without requiring a rewrite of the software.

If Jumper J9 is ON, some of the new features of the ER5000 will not function, including Suspend Mode and some Profile commands (*Soak*, *If*, *Goto*). Also some internal variables switch from 16-bit to 12-bit and must be configured to the correct scale. Refer to the *Internal Variables* section for specific information on the affected variables.

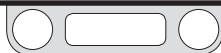

ER5000 — Troubleshooting

Operation

Checking the LED Indicators

⚠ WARNING

⚠ Be aware that the controller is connected to the power supply and that critical components of the controller are exposed when the cover is removed to inspect the LED indicators. Always use extreme caution when the cover is removed.

Figure 64 shows the position of the four LED indicators on the circuit board of the ER5000. The LED indicators give you a quick visual reference to evaluate the status of the controller.

During installation, use LED1 (red) and LED4 (red) to verify that you have correctly wired the ER5000 to its power supply.

If you are communicating via RS485, for example as part of a daisychain on a network, LED2 (green) and LED3 (amber) verify that the ER5000 is sending and receiving data.

NOTE Refer to page 89 through page 93 for correct wiring to connect the ER5000 to an RS485 converter.

NOTE LED2 and LED3 respond to data transmission when the ER5000 communicates using RS485. These LEDs do not respond to data transmission when the ER5000 communicates using USB and may be on or off depending on the specific configuration of your application. They do not need to be checked during installation or operation when USB is used.

The LEDs can help you troubleshoot controllers that are not functioning properly.

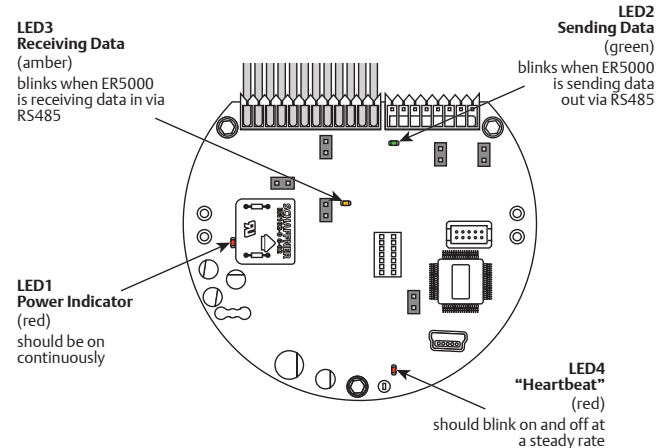
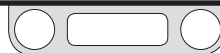

Figure 64: LED Indicators



ER5000 — Troubleshooting

Operation

Using the LED Indicators to Verify Power Supply During Power-up

1. Power up the ER5000.
2. Check the LED indicators on the ER5000. They should appear as follows:
 - LED1 = ON
 - LED4 = BLINKING
3. If the LED indicators do not appear this way, refer to *Power Supply Wiring — All Applications* and verify that the ER5000 is correctly wired to the power supply.

Using the LED Indicators to Verify RS485 Communication

1. Power up the ER5000 and verify the power supply, as described above.
2. Open the ERTune™ program.
3. Check the LED indicators on the ER5000. They should appear as follows:
 - LED2 = FLASHING ON AND OFF
 - LED3 = FLASHING ON AND OFF
4. If the LED indicators do not appear this way, refer to *page 89 through page 93*, depending on your application and verify that the ER5000 is correctly wired to the RS485 converter.

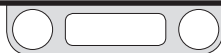

ER5000 — Troubleshooting

Operation

Opening the ERTune™ Program

IMPORTANT! The ER5000 must be powered up and connected to the PC via USB or RS485 in order to open the ERTune™ program.

You should close the ERTune™ program before powering down the controller or disconnecting the communication cable.

The ERTune™ program should open directly when the controller is connected and powered up.

NOTE The Comm Error window may appear briefly when the ERTune™ program opens during normal operation. Allow 10-20 seconds before taking troubleshooting action.

If the Comm Error (Communications Error) window opens and remains open for longer than 20 seconds, follow these steps:

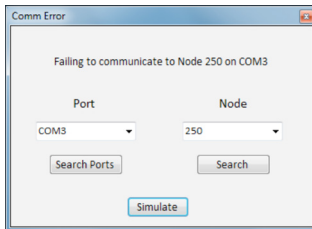

1. Check all power and communication wiring per your application.
2. Click the Search Ports button. The ERTune™ program scans all COM ports that are in use.
3. Click the Search button below the Node Address. The ERTune™ program scans all 250 Node Addresses.
4. If the program does not open, close the Comm Error window and check that the ER5000 is correctly configured to communicate with the PC.
 - a. If you are communicating via RS485 refer to *Using the LED Indicators to Verify RS485 Communication*.
 - b. If you are communicating via USB, follow these steps:
 - > If the controller is correctly configured but the program still does not open, unplug the USB cable from the PC, then plug it back in.
 - > If the program still does not open, power down and power up the ER5000.
 - > If the program still does not open, follow the steps on page 204 or page 205 and re-install the ER5000 device driver.
5. If the problem persists, contact TESCOM™ support.



ER5000 — Troubleshooting

Operation

Checking the ERTune™ Menu Bar for Warnings

The Menu Bar of ERTune™ program displays two warnings: No Feedback and Simulation.

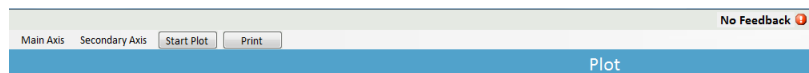

The No Feedback warning indicates that the program is communicating with the controller, but is not receiving a feedback signal.

This warning generally indicates a wiring problem. Refer to the [Getting Started](#) or the [Installation Variations](#) section to find the correct wiring for your application and verify that your wiring has been installed correctly.

- A common error is not connecting the yellow wire (pin 4) and the tan wire (pin 12) when using a 4–20 mA feedback transducer.
- Also check to make sure the voltage/current select jumpers are in the proper position for your application. Refer to [Checking the Configuration of the Jumpers](#) earlier in this section.

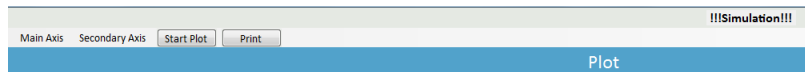

The Simulation warning indicates that the ERTune™ program has been opened in Simulation Mode.

In Simulation Mode, the program responds normally to controls. However, it does not actively communicate with a controller, even if the controller is powered up and properly connected.

Simulation Mode is useful for training purposes, but should be closed when you wish to communicate with the ER5000.

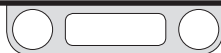

ER5000 — Troubleshooting

Operation

Checking the Pressure Connections if the ER5000 Does Not Respond Properly to Setpoint Changes

⚠ WARNING

- **⚠** Never connect the controller or any associated equipment to a supply source having a pressure greater than the maximum rated pressure of this controller or the associated equipment.
- Supply pressure must be clean, dry inert gas or air that meets the requirements of ISA Standard 7.0.01.
- The ER5000 exhausts pilot pressure to the surrounding atmosphere. When installing this unit in a confined area, the exhaust port should be remotely vented to a safe location to prevent asphyxiation due to lack of Oxygen in the surrounding atmosphere.

If there is a problem with controlling the pressure:

1. Check the pneumatic connections.
 - The inlet pressure must go into the Inlet Port, which is the left port (as shown in Figure 65). There must be a proper air tight seal, using a connector such as the TESCOM™ 80129 1/8" NPTF male tube connector.

(continued next page)

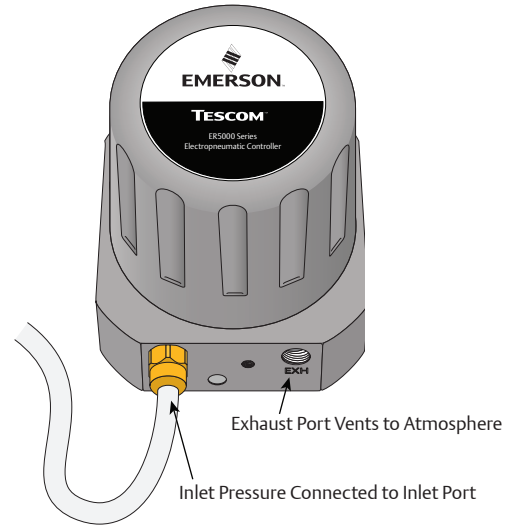

Figure 65: Proper Installation of Inlet Pressure



ER5000 — Troubleshooting

Operation

Checking the Pressure Connections if the ER5000 Does Not Respond Properly to Setpoint Changes (cont.)

- Inlet pressure should be 110 psig / 7.5 bar, with a maximum of 120 psig / 8.2 bar.
- NOTE** Minimum inlet pressure is 1 psi above the required output of the ER5000.
- The gauge port must be plugged if a gauge is not installed, as shown in Figure 66. If a gauge is installed, there must be a proper air tight seal.
2. Open the ERTune™ program and check the Control Mode, as displayed in The ER Settings Panel and setpoint source, as displayed in The Setpoint Panel.
 3. If you are using an analog setpoint source, check that the Analog setpoint source is selected in The Setpoint Panel. Also check to make sure the voltage/current select jumpers are in the proper position for your application. Refer to Checking the Configuration of the Jumpers earlier in this section.
 4. Check the values of the PID parameters as displayed in The PID Control Panel.

(continued next page)

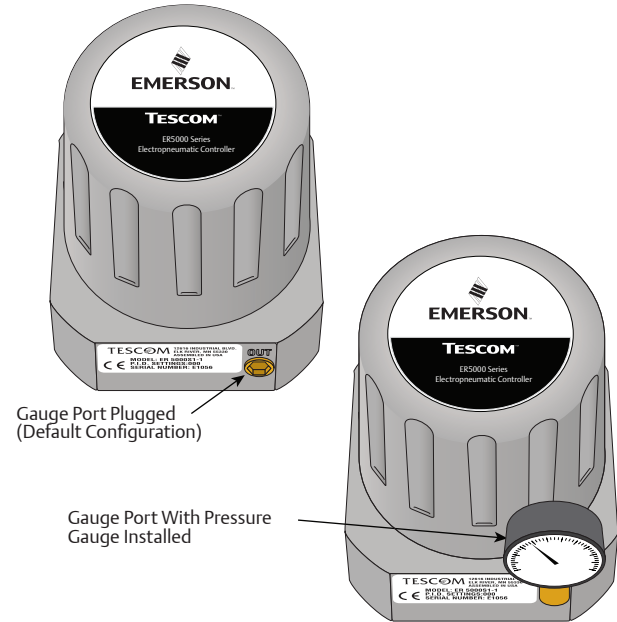
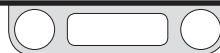

Figure 66: Gauge Port Plugged and with Pressure Gauge Installed



ER5000 — Troubleshooting

Operation

Checking the Pressure Connections if the ER5000 Does Not Respond Properly to Setpoint Changes (cont.)

5. Make sure that a Control Limit has not been triggered. Refer to The Control Limits Panel for more information.
6. If the problem persists, use The Plot Screen Buttons — The Print Button to take a snapshot of your current configuration and gather all tuning parameters, then contact your TESCOTM representative.



Operation

Checking the Solenoid Valves for Leaks

The ERTune™ program includes an automated test for the Inlet and Exhaust valves of the controller. Refer to [The ER Solenoid Leak Test Panel](#) section for a step-by-step explanation of the process.

Checking Other Components of the Application for Leaks

TESCOM™ includes a suite of diagnostic tools and reference materials in [The Diagnostic Tools Tab](#) of the ERTune™ program. Reference [The System Check Panel](#) and [The Regulator Leak Check Panel](#) as a first step towards problem solving.

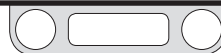
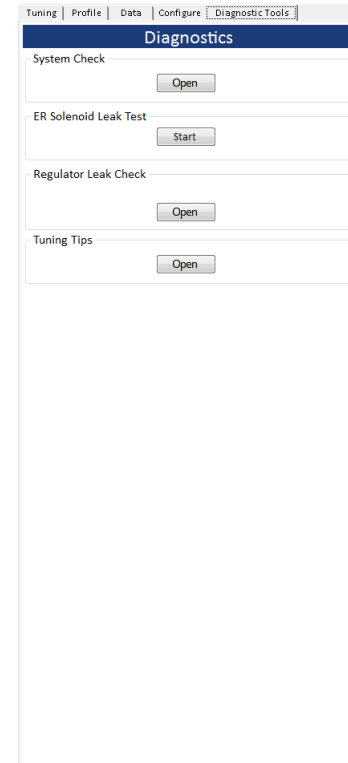

ER5000 — Troubleshooting

RS485 Communication

TESCOM™ Model # 82948 USB to RS485 Converter

Locate the four DIP switches on the back of the converter. The switches should be configured as follows:

- RS485
- Echo OFF
- 2 Wire
- 2 Wire

Third Party RS232 to RS485 Converters

RS232 to RS485 converters range in modes of operation. If your application requires an RS232 to RS485 converter, it must be configured as follows:

- Echo off.
- Transmitted data, SD, is used for flow control.
- No handshake control (RTS/CTS, DSR/DTR)

Additionally, for 4-wire RS422 converters (half duplex):

- Connect: +TD to +RD
- Connect: –TD to –RD

Acceptable Resistance Values

The resistance values must be measured with all external wiring disconnected, including the power. Ensure converter screw terminals are tight.

Resistance levels outside the acceptable ranges may indicate damaged RS485 components on the ER5000. Contact your TESCOM representative.

ER5000 RS485 Interface

- +RS485 to GND = 10K Ω to 50K Ω
- –RS485 to GND = 10K Ω to 50K Ω

Converter RS485 Interface

- +RS485 to GND = 3K Ω to 5K Ω
- –RS485 to GND = 900 Ω to 1.2K Ω

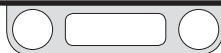

ER5000 — Troubleshooting

Using Profiles to Control the ER5000

Profiles are multi-step command sequences for the ER5000. They require no previous programming experience on the part of the user to create and guide the ER5000 through everything from a simple start/stop operation to a sequence of setpoint changes that can include up to one hundred command lines and control loops that can run indefinitely.

Problems with Profiles can generally be attributed to applications where a Profile includes command segments where the controller communicates with an external digital device. Troubleshooting these applications generally involves checking that all wiring is configured properly and correctly setting the internal variables which control how the ER5000 interprets digital signals.

Input – If the Profile Stops at a Digital Input Command for Digital Input 1

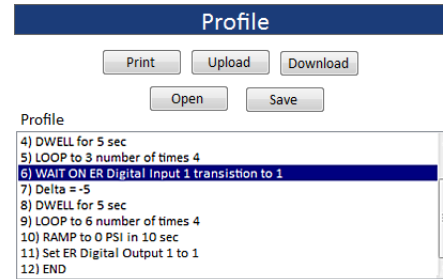

1. Check **Jumper J14**. It must be **OFF** to use Input 1 as a digital input. Refer to [Checking the Configuration of the Jumpers](#) earlier in this section.
2. Check variable #77 (ID_COMPENSATED_EXTRA_AD1). The value should read higher when the input is activated (Logical 1) than when not activated (Logical 0).
3. Use one of the extra variables on the plot screen to monitor Extra Analog Input 1 (77). Follow the steps in [To add a variable to the Plot Screen display](#).

OR

Use a Read/Write field in The Read/Write Panel to monitor 77:COMP_EXTRA-AD1.

(continued next page)

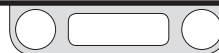

ER5000 — Troubleshooting

4. If variable #77 isn't reading properly, check wiring. Refer to the Profile with External Control/Digital Inputs wiring configuration.
5. Use a Read/Write field in The Read/Write Panel to monitor and, if necessary change, 85:AD_EXTRA1-TOGGLE. Variable #85 (ID_AD_EXTRA1_TOGGLE) is used to adjust the level at which the ER5000 interprets variable #77 as a Logical 0 or a Logical 1.

To change the level at which the input switches between Logical 0 and Logical 1, use the Write feature.

- 85:AD_EXTRA1-TOGGLE is a 12-bit variable with a range of 400–3700, where a value of 400 counts is 0% and 3700 counts is 100%. To convert between counts and percent, use the following formulas:
$$\text{value_percent} = (\text{value_counts} - 400) * 100 / 3,300$$
$$\text{value_counts} = (\text{value_percent} * 3,300 / 100) + 400$$
- The default toggle level is 50% or 2050 counts.
- The ER5000 Software includes a Unit Converter program which can assist you in conversion calculations. It is accessed by clicking the Unit Converter button in the Resources section. Refer to the ER5000 Software Development Support section for more information on accessing the Resources section.

Input – If the Profile Does Not Start at a Digital Input from Digital Input 2

1. Check **Jumper J15**. It must be **OFF** to use Input 2 as a digital input. Refer to Checking the Configuration of the Jumpers earlier in this section.
2. Check variable #78 (ID_COMPENSATED_EXTRA_AD2). The value should read higher when the input is activated (Logical 1) than when not activated (Logical 0).
3. Use one of the extra variables on the plot screen to monitor Extra Analog Input 1 (78). Follow the steps in To add a variable to the Plot Screen display.
OR
Use a Read/Write field in The Read/Write Panel to monitor 78:COMP_EXTRA-AD1.
4. If variable #78 isn't reading properly, check wiring. Refer to the Profile with External Control/Digital Inputs wiring configuration.
5. Use a Read/Write field in The Read/Write Panel to monitor and, if necessary change, 86:AD_EXTRA2-TOGGLE. Variable #86 (ID_AD_EXTRA2_TOGGLE) is used to adjust the level at which the ER5000 interprets variable #78 as a Logical 0 or a Logical 1.
To change the level at which the input switches between Logical 0 and Logical 1, use the Write feature.

(continued next page)

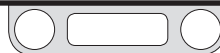

ER5000 — Troubleshooting

- 86:AD_EXTRA2-TOGGLE is a 12-bit variable with a range of 400–3700, where a value of 400 counts is 0% and 3700 counts is 100%. To convert between counts and percent, use the following formulas:
$$\text{value_percent} = (\text{value_counts} - 400) * 100 / 3,300$$
$$\text{value_counts} = (\text{value_percent} * 3,300 / 100) + 400$$
- The default toggle level is 50% or 2050 counts.
- The ER5000 Software includes a Unit Converter program which can assist you in conversion calculations. It is accessed by clicking the Unit Converter button in the Resources section. Refer to the ER5000 Software Development Support section for more information on accessing the Resources section.



ER5000 — Troubleshooting

Using Profiles to Control the ER5000

Output – If the Profile Doesn't Activate Digital Load 1

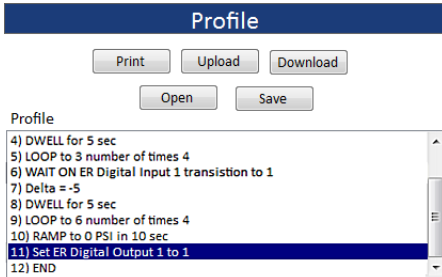

1. Use a Read/Write field in The Read/Write Panel to monitor 88:DIGITAL_OUTPUT1 while running the Profile. The value should read “1” when the input is activated and should read “0” when not activated.
2. If variable #88 (ID_DIGITAL_OUTPUT1) is reading properly, follow these steps:
 - a. Check the wiring. Refer to the wiring diagram for Digital Outputs.
 - b. Ensure the power being supplied to the load is sufficient for the device and the application.

Output – If the Profile Doesn't Activate Digital Load 2

1. Use a Read/Write field in The Read/Write Panel to monitor 89:DIGITAL_OUTPUT2 while running the Profile. The value should read “1” when the input is activated and should read “0” when not activated.
2. If variable #89 (ID_DIGITAL_OUTPUT2) is reading properly, follow these steps:
 - a. Check the wiring. Refer to the wiring diagram for Digital Outputs.
 - b. Ensure the power being supplied to the load is sufficient for the device and the application.





INTERNAL VARIABLES

ER5000 — Internal Variables

Table of ER5000 Internal Variables

Table 27: ER5000 Internal Variables

Variable Index and Name	Access	Type	Range:Decimal	Range:Hex
00-ID_INNER_ACTUAL_ERROR	RO	Signed	-4095:4095	-0fff:0fff
01-ID_AD_SETPOINT	RO	Unsigned	0:65535	0:ffff
02-ID_TEMP_ADJUST	RW	Unsigned	0:65535	0:ffff
03-ID_INNER_D_COEF1	RW	Signed	-32768:32767	-8000:7fff
04-ID_INNER_D_COEF2	---	---	---	---
05-ID_COMPENSATED_EXTERNAL_SENSOR	RO	Unsigned	0:65535	0:ffff
06-ID_COMPENSATED_INTERNAL_SENSOR	RO	Unsigned	0:65535	0:ffff
07-ID_RAW_EXTERNAL_SENSOR	RO	Unsigned	0:65535	0:ffff
08-ID_RAW_INTERNAL_SENSOR	RO	Unsigned	0:65535	0:ffff
09-ID_CONTROL_MODE	RW	Signed	0:3	0:3
10-ID_INNER_DERIVATIVE	RO	Signed	-32768:32767	-8000:7fff
11-ID_INNER_EFFECTIVE_ERROR	RO	Signed	-32768:32767	-8000:7fff
12-ID_PWM_SHUTOFF_FLAG	RW	Unsigned	0:1	0:1
13-ID_RTTASK_DELAY	RW	Unsigned	0:65535	0:ffff
14-ID_OUTER_ACTUAL_ERROR	RO	Signed	-4095:4095	-0fff:0fff
15-RESERVED	---	---	---	---
16-ID_OUTER_D_COEF1	RW	Signed	-32768:32767	-8000:7fff
17-RESERVED	---	---	---	---
18-ID_OUTER_EFFECTIVE_ERROR	RO	Signed	-32768:32767	-8000:7fff
19-ID_INNER_SENSOR_MIN	RW	Unsigned	0:4095	0:0fff
20-ID_INNER_SENSOR_MAX	RW	Unsigned	0:4095	0:0fff
21-ID_OUTER_INTEGRAL_CONSTANT	RW	Signed	-32768:32767	-8000:7fff
22-ID_OUTER_INTEGRAL_MAXIMUM	RW	Signed	-32768:32767	-8000:7fff

Variable Index and Name	Access	Type	Range:Decimal	Range:Hex
23-ID_OUTER_INTEGRAL_SUM	RW	Signed	-32768:32767	-8000:7fff
24-RESERVED	---	---	---	---
25-ID_OUTER_PROPORTIONAL_CONSTANT	RW	Signed	-32768:32767	-8000:7fff
26-ID_FACTORY_MIN_INLET	RW	Unsigned	0:250	0:fa
27-ID_FACTORY_MIN_EXHAUST	RW	Unsigned	0:250	0:fa
28-ID_INNER_INTEGRAL_CONSTANT	RW	Signed	-32768:32767	-8000:7fff
29-ID_INNER_INTEGRAL_MAXIMUM	RW	Signed	-32768:32767	-8000:7fff
30-ID_INNER_INTEGRAL_SUM	RW	Signed	-32768:32767	-8000:7fff
31-RESERVED	---	---	---	---
32-RESERVED	---	---	---	---
33-RESERVED	---	---	---	---
34-ID_OUTPUT	RO	Signed	-32768:32767	-8000:7fff
35-ID_INNER_PROPORTIONAL_CONSTANT	RW	Signed	-32768:32767	-8000:7fff
36-ID_COMP_TEMP_SENSOR	RO	Unsigned	0:65535	0:ffff
37-ID_SETPOINT	RW	Unsigned	0:4095	0:0fff
38-ID_RAW_TEMP_SENSOR	RO	Unsigned	0:4095	0:0fff
39-ID_GAIN	RW	Unsigned	0:65535	0:ffff
40-ID_OSET	RW	Unsigned	0:65535	0:ffff
41-ID_ARDG	RO	Unsigned	0:65535	0:ffff
42-ID_NODE	RW	Unsigned	1:250	1:fa
43-ID_SETPOINT_FLAG	RW	Signed	0:4	0:4
44-ID_FEEDBACK	RO	Unsigned	0:4095	0:0fff
45-ID_PROFILE_LOOP_COUNT	RO	Unsigned	0:30000	0:7530



ER5000 — Internal Variables

Variable Index and Name	Access	Type	Range:Decimal	Range:Hex
46-ID_SOLENOID_DIRECTION	RW	Signed	0:1	0:1
47-ID_MIN_INLET	RW	Unsigned	0:250	0:fa
48-ID_MIN_EXHAUST	RW	Unsigned	0:250	0:fa
49-ID_OUTER_INTEGRAL_MINIMUM	RW	Signed	-32768:32767	-8000:7fff
50-ID_INNER_INTEGRAL_MINIMUM	RW	Signed	-32768:32767	-8000:7fff
51-ID_RAW_AD_SETPOINT	RO	Unsigned	0:65535	0:ffff
52-ID_SERIAL_NUMBER	RW	Unsigned	0:65535	0:ffff
53-ID_VERSION_NUMBER	RW	Unsigned	0:65535	0:ffff
54-ID_MIN_AD_SETPOINT	RW	Unsigned	0:4095	0:0fff
55-ID_MAX_AD_SETPOINT	RW	Unsigned	0:4095	0:0fff
56-ID_MIN_COMPENSATED_INTERNAL_SENSOR	RW	Unsigned	0:4095	0:0fff
57-ID_MAX_COMPENSATED_INTERNAL_SENSOR	RW	Unsigned	0:4095	0:0fff
58-ID_MIN_COMPENSATED_EXTERNAL_SENSOR	RW	Unsigned	0:4095	0:0fff
59-ID_MAX_COMPENSATED_EXTERNAL_SENSOR	RW	Unsigned	0:4095	0:0fff
60-ID_MIN_INNER_ACTUAL_ERROR	RW	Signed	-32768:32767	-8000:7fff
61-ID_MAX_INNER_ACTUAL_ERROR	RW	Signed	-32768:32767	-8000:7fff
62-ID_MIN_OUTER_ACTUAL_ERROR	RW	Signed	-32768:32767	-8000:7fff
63-ID_MAX_OUTER_ACTUAL_ERROR	RW	Signed	-32768:32767	-8000:7fff
64-ID_PWM_CONTROL_LIMIT_STATE	RW	Signed	0:3	0:3
65-ID_PWM_VALUE	RO	Signed	-250:250	-fa:fa
66-ID_INNER_INTEGRAL_DEADBAND	RW	Unsigned	0:4095	0:0fff
67-ID_OUTER_INTEGRAL_DEADBAND	RW	Unsigned	0:4095	0:0fff
68-ID_FEEDBACK_FILTER	RW	Unsigned	0:1	0:1
69-ID_PROFILE_TYPE	RO	Unsigned	0:11	0:b

Variable Index and Name	Access	Type	Range:Decimal	Range:Hex
70-ID_PROFILE_STATE	RW	Unsigned	0:2	0:2
71-ID_PROFILE_STEP	RO	Unsigned	0:31	0:1f
72-ID_ESTOP_FLAG	RW	Unsigned	0:1	0:1
73-ID_PULSE	RW	Unsigned	1798:2298	0706:08fa
74-ID_EXTRA_AD1	RO	Unsigned	0:65535	0:ffff
75-ID_EXTRA_AD2	RO	Unsigned	0:65535	0:ffff
76-RESERVED	---	---	---	---
77-ID_COMPENSATED_EXTRA_AD1	RO	Unsigned	0:65535	0:ffff
78-ID_COMPENSATED_EXTRA_AD2	RO	Unsigned	0:65535	0:ffff
79-ID_RANGE_MIN_INLET	RW	Unsigned	0:20	0:14
80-ID_RANGE_MIN_EXHAUST	RW	Unsigned	0:20	0:14
81-ID_PULSE_PERIOD	RW	Unsigned	0:200	0:c8
82-ID_PULSE_WIDTH	RW	Unsigned	0:250	0:fa
83-ID_PULSE_DEADBAND	RW	Unsigned	0:330	0:14a
84-ID_PULSE_ENABLE	RW	Unsigned	0:1	0:1
85-ID_AD_EXTRA1_TOGGLE	RW	Unsigned	0:4095	0:0fff
86-ID_AD_EXTRA2_TOGGLE	RW	Unsigned	0:4095	0:0fff
87-ID_EXT_FEEDBACK_SOURCE	RW	Unsigned	0:1	0:1
88-ID_DIGITAL_OUTPUT1	RW	Unsigned	0:1	0:1
89-ID_DIGITAL_OUTPUT2	RW	Unsigned	0:1	0:1
90-ID_DIGITAL_OUT1_INIT	RW	Unsigned	0:1	0:1
91-ID_DIGITAL_OUT2_INIT	RW	Unsigned	0:1	0:1
92-ID_DA_ANALOG_OUT	RW	Unsigned	0:4095	0:0fff
93-ID_TTL_ERR0	RW	Unsigned	0:4095	0:0fff



ER5000 — Internal Variables

Variable Index and Name	Access	Type	Range:Decimal	Range:Hex
94 - ID_TTL_ERR4095	RW	Unsigned	0 : 4095	0 : 0fff
95 - ID_DA_ANALOG_WRITE_FLAG	RW	Unsigned	0 : 1	0 : 1
96 - ID_TTL_FLAG	RW	Unsigned	0 : 1	0 : 1
97 - ID_DIAPHRAGM_PROTECT_ENABLE	RW	Unsigned	0 : 1	0 : 1
98 - ID_SENSOR_FLAG	RW	Unsigned	0 : 1	0 : 1
99 - ID_DIAPHRAGM_PROTECT_OFFSET	RW	Unsigned	0 : 4095	0 : 0fff
100 - ID_CAL_OFFSET_ANALOG_SP	RW	Signed	-32768 : 32767	-8000 : 7fff
101 - ID_CAL_GAIN_ANALOG_SP	RW	Unsigned	0 : 65535	0 : ffff
102 - ID_CAL_OFFSET_EXTERNAL_FB	RW	Signed	-32768 : 32767	-8000 : 7fff
103 - ID_CAL_GAIN_EXTERNAL_FB	RW	Unsigned	0 : 65535	0 : ffff
104 - ID_CAL_OFFSET_EXTRA1	RW	Signed	-32768 : 32767	-8000 : 7fff
105 - ID_CAL_GAIN_EXTRA1	RW	Unsigned	0 : 65535	0 : ffff
106 - ID_CAL_OFFSET_EXTRA2	RW	Signed	-32768 : 32767	-8000 : 7fff
107 - ID_CAL_GAIN_EXTRA2	RW	Unsigned	0 : 65535	0 : ffff
108 - RESERVED	---	---	---	---
109 - RESERVED	---	---	---	---
110 - RESERVED	---	---	---	---

Variable Index and Name	Access	Type	Range:Decimal	Range:Hex
111 - RESERVED	---	---	---	---
112 - ID_CAL_OFFSET_ANALOG_OUT	RW	Signed	-32768 : 32767	-8000 : 7fff
113 - ID_CAL_GAIN_ANALOG_OUT	RW	Unsigned	0 : 65535	0 : ffff
114 - RESERVED	---	---	---	---
115 - RESERVED	---	---	---	---
116 - RESERVED	---	---	---	---
117 - RESERVED	---	---	---	---
118 - RESERVED	---	---	---	---
119 - ID_PROFILE_STARTRUN	RW	Unsigned	0 : 1	0 : 1
120 - ID_MODE_ER3000_ER5000	RO	Unsigned	0 : 1	0 : 1
121 - ID_SUSPEND	RO	Unsigned	0 : 1	0 : 1
122 - ID_SETPOINT_RESET	RW	Unsigned	0 : 1	0 : 1
123 - ID_DAC_INT_SENSOR_OFFSET	RW	Signed	0 : 4095	0 : fff
124 - ID_DAC_INT_SENSOR_GAIN	RW	Unsigned	0 : 4095	0 : fff
125 - ER5000_TAG	RO	Unsigned	0 : 65535	0 : ffff
126 - RESERVED	---	---	---	---
127 - RESERVED	---	---	---	---



ER5000 — Internal Variables

ER5000 Internal Variables

The ER5000 has a number of internal variables which can be accessed via the USB or RS485 interface. The most commonly used variables are listed below. The variable index number, name and description are shown. The index number is the value selected from the drop-down list in the Variables field of The Read/Write Panel in The Power User Tab of the ERTune™ program to access the specified variable. A complete list of internal variables is shown in Table 27.

ER5000 Setpoint and Feedback Variables

NOTE For variable #37 (ID_SETPOINT) and variable #44 (ID_FEEDBACK), a value of 400 counts is 0% and 3700 counts is 100%. To convert between counts and percent, use the following formulas:

- $\text{value_percent} = (\text{value_counts} - 400) * 100 / 3,300$
- $\text{value_counts} = (\text{value_percent} * 3,300 / 100) + 400$

37 ID_SETPOINT

This is the controller's setpoint.

43 ID_SETPOINT_FLAG

This variable determines the source of the setpoint, variable #37 (ID_SETPOINT).

- 0 => setpoint from A/D, analog setpoint input
- 1 => setpoint from RS485 or USB network, typically a PC
- 2 => setpoint from internal Profile
- 3=> setpoint from A/D, analog setpoint input, while in Profile Mode
- 4=> Monitor Setpoint from external device while running the ERTune™ program

44 ID_FEEDBACK

This is the controller's overall feedback signal. For internal sensor mode it is the same as inner feedback. For external sensor mode or cascade mode it equals the outer loop feedback.

87 ID_EXT_FEEDBACK_SOURCE

This variable determines the source of the external feedback.

- 0 => feedback from the compensated external sensor, see variable #5 (ID_COMPENSATED_EXTERNAL_SENSOR)
- 1 => feedback from extra analog input 1, see variable #77 (ID_COMPENSATED_EXTRA_AD1)



ER5000 — Internal Variables

ER5000 Configuration Variables

09 ID_CONTROL_MODE

This variable establishes the control mode for the controller. A value of four only occurs when a Control Limit has been exceeded. See variables #54 (ID_MIN_AD_SETPOINT) through #64 (CONTROL_LIMIT_STATE). A value of five only occurs if the controller is in ESTOP, emergency stop, mode.

- 0 => internal feedback mode
- 1 => external feedback mode
- 2 => cascade mode
- 3 => manual mode
 - setpoint = 0x08fa => inlet open
 - setpoint = 0x0800 => solenoids closed
 - setpoint = 0x0706 => exhaust open
- 4 => control limit mode (read only)
- 5 => emergency stop (read only)

42 ID_NODE

This is the unit's network Node Address. Note that if this variable is changed then all future communication must be addressed to the new Node Address.

52 ID_SERIAL_NUMBER

This is the serial number for the unit. It is programmed at the factory and should not be changed by the user.

53 ID_VERSION_NUMBER

This is the version number of the embedded software.

120 ID_MODE_ER3000_ER5000

This is the selected mode of operation determined by either installing or removing Jumper J9.

- 0 => ER5000 mode
- 1 => ER3000 mode

NOTE The unit must be powered down/up for the jumper change to be recognized.

122 ID_SETPONT_RESET

This variable establishes the startup setpoint of the ER5000. When it is activated (value = 1) the ER5000 will startup at zero.

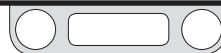

ER5000 — Internal Variables

ER5000 Inner Loop Tuning Variables

NOTE Variable #6 (ID_COMPENSATED_INTERNAL_SENSOR) is **16-bit** when the controller is in ER5000 mode (Jumper J9 = OFF, variable #120 (ID_MODE_ER3000_ER5000) => 0). When the controller is in ER5000 mode, a value of 6400 counts is 0% and 59200 counts is 100%. To convert between counts and percent, use the following formulas:

- $\text{value_percent} = (\text{value_counts}16 - 6,400) * 100 / 52,800$
- $\text{value_counts}16 = (\text{value_percent} * 52,800 / 100) + 6,400$

Variable #6 is **12-bit** when the controller is in ER3000 mode (Jumper J9 = ON, variable #120 (ID_MODE_ER3000_ER5000) => 1). When the controller is in 12-bit ER3000 mode, a value of 400 counts is 0% and 3700 counts is 100%. To convert between counts and percent, use the following formulas:

- $\text{value_percent} = (\text{value_counts} - 400) * 100 / 3,300$
- $\text{value_counts} = (\text{value_percent} * 3,300 / 100) + 400$

03 ID_INNER_D_COEF1

This is the D-term, Derivative constant, for the inner loop.

06 ID_COMPENSATED_INTERNAL_SENSOR

This is the compensated internal sensor value, after temperature compensation, zero and span have been applied to the raw signal. A value of 6400 is 0% and 59200 is 100%. When the controller is in ER5000 mode, this variable records data in 16-bit mode, which gives more accurate data acquisition than variable #44 (ID_FEEDBACK).

28 ID_INNER_INTEGRAL_CONSTANT

This is the I-term, Integral Constant, for the inner loop.

29 ID_INNER_INTEGRAL_MAXIMUM

This is the maximum value allowed for the Integral sum on the inner loop.

30 ID_INNER_INTEGRAL_SUM

This is the value of the Integral sum for the inner loop. It is formed by multiplying the Integral constant times the error and summing the result with the previous value for the Integral sum.

35 ID_INNER_PROPORTIONAL_CONSTANT

This is the P term (Proportional Constant) for the inner loop.

50 ID_INNER_INTEGRAL_MINIMUM

This is the minimum value allowed for the Integral sum on the inner loop.

66 ID_INNER_INTEGRAL_DEADBAND

This is the inner loop minimum error required for the Integral sum to be changing in value. Often it is set to zero and has no effect. However, if it is desirable to stop integrating once the error is reduced below a certain value, for instance when using an external dome-loaded regulator which has hysteresis, then this parameter should be set to the minimum acceptable error.



ER5000 — Internal Variables

ER5000 Outer Loop Tuning Variables

16 ID_OUTER_D_COEF1

This is the D term (Derivative Constant) for the outer loop.

21 ID_OUTER_INTEGRAL_CONSTANT

This is the I term (Integral Constant) for the outer loop.

22 ID_OUTER_INTEGRAL_MAXIMUM

This is the maximum value allowed for the Integral sum on the outer loop.

23 ID_OUTER_INTEGRAL_SUM

This is the value of the Integral sum for the outer loop. It is formed by multiplying the Integral constant times the error and summing the result with the previous value for the Integral sum.

25 ID_OUTER_PROPORTIONAL_CONSTANT

This is the P term (Proportional Constant) for the outer loop.

49 ID_OUTER_INTEGRAL_MINIMUM

This is the minimum value allowed for the Integral sum on the outer loop.

67 ID_OUTER_INTEGRAL_DEADBAND

This is the outer loop minimum error required for the Integral sum to be changing in value. Often it is set to zero and has no effect. However, if it is desirable to stop integrating once the error is reduced below a certain value, for instance when using an external dome-loaded regulator which has hysteresis, then this parameter should be set to the minimum acceptable error.



ER5000 — Internal Variables

ER5000 Analog Input Variables

NOTE For the following variables:

- variable #1 (ID_AD_SETPOINT)
- variable #5 (ID_COMPENSATED_EXTERNAL_SENSOR)
- variable #77 (ID_COMPENSATED_EXTRA_AD1)
- variable #78 (ID_COMPENSATED_EXTRA_AD2)

These variables are **16-bit** when the controller is in ER5000 mode (Jumper J9 = OFF, variable #120 (ID_MODE_ER3000_ER5000) => 0). When the controller is in ER5000 mode, a value of 6400 counts is 0% and 59200 counts is 100%. To convert between counts and percent, use the following formulas:

- $\text{value_percent} = (\text{value_counts}16 - 6,400) * 100 / 52,800$
- $\text{value_counts}16 = (\text{value_percent} * 52,800 / 100) + 6,400$

These variables are **12-bit** when the controller is in ER3000 mode (Jumper J9 = ON, variable #120 (ID_MODE_ER3000_ER5000) => 1). When the controller is in 12-bit ER3000 mode, a value of 400 counts is 0% and 3700 counts is 100%. To convert between counts and percent, use the following formulas:

- $\text{value_percent} = (\text{value_counts} - 400) * 100 / 3,300$
- $\text{value_counts} = (\text{value_percent} * 3300 / 100) + 400$

01 ID_AD_SETPOINT

This is the value of the analog setpoint. A value of 6400 is 0% and 59200 is 100%. Note that the analog setpoint is not used unless the controller is programmed to use it by variable #43 (ID_SETPOINT_FLAG). When the controller is in ER5000 mode, this variable records data in 16-bit mode, which gives more accurate data acquisition than variable #37 (ID_SETPOINT).

05 ID_COMPENSATED_EXTERNAL_SENSOR

This is the compensated external sensor value, after linearization, zero and span have been applied to the raw signal. A value of 6400 is 0% and 59200 is 100%. When the controller is in ER5000 mode, this variable records data in 16-bit mode, which gives more accurate data acquisition than variable #44 (ID_FEEDBACK).

77 ID_COMPENSATED_EXTRA_AD1

This input is available only on “F” models. This is the compensated external analog input value, after linearization has been applied to the raw signal. A value of 6400 is 0% and 59200 is 100%.



ER5000 — Internal Variables

78 ID_COMPENSATED_EXTRA_AD2

This input is available only on “F” models. This is the compensated external analog input value, after linearization has been applied to the raw signal. A value of 6400 is 0% and 59200 is 100%.

85 ID_AD_EXTRA1_TOGGLE

This variable is used to adjust the level that the ER5000 interprets variable #77 (ID_COMPENSATED_EXTRA_AD1) as a Logical 0 or a Logical 1.

86 ID_AD_EXTRA2_TOGGLE

This variable is used to adjust the level that the ER5000 interprets variable #78 (ID_COMPENSATED_EXTRA_AD2) as a Logical 0 or a Logical 1.

ER5000 Pressure Profile Variables

45 ID_PROFILE_LOOP_COUNT

This variable displays the count of times through a Profile loop. The counter starts at the number of loops entered in the Number of Loops (0=>forever) field of the Profile Builder when the Loop command segment is added to the Profile and decrements by one at each loop of the count.

69 ID_PROFILE_TYPE

This is the type of the profile step currently active.

- 0 => STOP
- 1 => RAMP
- 2 => STEP
- 3 => DWELL
- 4 => DIGITAL OUTPUT
- 5 => DIGITAL INPUT
- 6 => LOOP
- 7 => CHANGE VARIABLE
- 8 => Delta
- 9 => If
- 10 => GoTo
- 11 => Soak

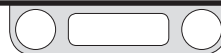

ER5000 — Internal Variables

70 ID_PROFILE_STATE

This is the run state of the profile.

- 0 => STOP
- 1 => START
- 2 => RUN

71 ID_PROFILE_STEP

This is the step in the profile which is currently being run.

119 ID_UI_PROFILE_STARTRUN

This is the restarting mode of the profile.

- 0 => Restart profile at the beginning
- 1 => Resume profile at current profile step

ER5000 Single “Puff” Solenoid Control Variable

73 ID_PULSE

This variable allows opening the inlet or exhaust for the specified duration for one pulse period. After one pulse duration, the variable is returned to a value of 0.

- 0x08fa => Inlet full open
- 0x0800 => Both valves closed
- 0x0706 => Exhaust full open

ER5000 Pulse Mode Variables

81 ID_PULSE_PERIOD

This controls the rate of the pulse while pulse mode is active. The value represents how many passes through the control algorithm (25 ms per pass) before sending a pulse to one of the solenoids.

82 ID_PULSE_WIDTH

This controls how long the solenoid is held open while pulse mode is active. Part of this number compensates for allowed system fluctuations (or noise) so too small a number will not open the solenoid valve.

83 ID_PULSE_DEADBAND

This is the error from the setpoint allowed for the pulse function to stop pulsing. This value is in counts read up from the sensor. One count of error is .03% and typically this number is in the range of 0–3.

84 ID_PULSE_ENABLE

This turns the pulse function ON(1) or OFF(0).



ER5000 — Internal Variables

ER5000 Analog and Digital Output Variables

88 ID_DIGITAL_OUTPUT1

This variable can be written directly by a program or by the embedded profile using the Digital Output command. This variable is written to Digital Output #1, which is J4 Pin 7 (blue wire).

89 ID_DIGITAL_OUTPUT2

This variable can be written directly by a program, by the embedded Profile using the Digital Output command or by the embedded code. The embedded code updates this output if variable #96 (ID_TTL_FLAG) enables this output as a within tolerance indicator. If enabled, variable #93 (ID_TTL_ERR0) and variable #94 (ID_TTL_ERR4095) are used to set the maximum error allowed, in counts, for a setpoint of 0 and 4095 counts respectively. The embedded code interpolates between these points to find the maximum error allowed for all other setpoint values. Reference *ER5000 Setpoint and Feedback Variables to translate between counts and percent*. This variable is written to Digital Output #2, which is J4 Pin 8 (white wire).

90 ID_DIGITAL_OUT1_INIT

Power-up state of variable #88 (ID_DIGITAL_OUTPUT1).

91 ID_DIGITAL_OUT2_INIT

Power-up state of variable #89 (ID_DIGITAL_OUTPUT2).

92 ID_DA_ANALOG_OUT

This is the value written to the D/A converter to generate the 0–10V or 4–20 mA output signal.

93 ID_TTL_ERR0

Maximum error allowed at 0 counts. See variable #89 (ID_DIGITAL_OUTPUT2).

94 ID_TTL_ERR4095

Maximum error allowed at 4095 counts. See variable #89 (ID_DIGITAL_OUTPUT2).

96 ID_TTL_FLAG

This variable enables (1) or disables (0) the usage of variable #89 (ID_DIGITAL_OUTPUT2) as a within tolerance indicator.



ER5000 — Internal Variables

ER5000 Pulse Width Modulation (PWM) Control Variables

12 ID_PWM_SHUTOFF_FLAG

This flag is only active if variable #13 (ID_RTTASK_DELAY) is not a 0 or 1 and designates what the ER5000 will send to the PWM every 25ms while it is delaying.

- 0 => Write the previously computed value to the PWM
- 1 => Write a 0 to the PWM

13 ID_RTTASK_DELAY

This variable is typically set to 0, allowing the control algorithm to generate a new value for the PWM every 25ms. Certain systems need a slower acting control system, which is allowed for using this variable. For example, writing a 4 to this variable will allow the control algorithm to compute a new PWM value every 100ms.

19 ID_INNER_SENSOR_MIN

This variable operation is typically disabled by writing a 0 to it. If not disabled, it allows for a minimum internal pressure. If the internal pressure is below the specified value, the exhaust valve will not be opened to decrease the pressure.

20 ID_INNER_SENSOR_MAX

This variable operation is typically disabled by writing a 4095 to it. If not disabled, it allows for a maximum internal pressure. If the internal pressure is above the specified value, the inlet valve will not be opened to increase the pressure.

34 ID_OUTPUT

This is the value of the output from the controller. It is this value which controls the ER5000's valves. A positive number will open the inlet valve and a negative number will open the outlet valve.

46 ID_SOLENOID

This variable determines which valve is open when the output is positive or negative. In normal mode, (0 => Normal) positive outputs open the inlet solenoid and negative outputs open the exhaust solenoid. In reversed mode, (1 => Reversed) positive outputs open the exhaust solenoid and negative outputs open the inlet solenoid. This is useful in reverse-acting systems (systems where increasing the pressure causes the process variable to decrease).

47 ID_MIN_INLET

This is the minimum value for the inlet pulse width modulator. The pulse width modulator's value ranges from 0 to 250.

This variable, along with variable #48 (ID_MIN_EXHAUST), sets the deadband for the system. This variable is solenoid

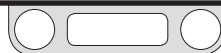

ER5000 — Internal Variables

dependent and typically has a value close to 10. Larger values can give tighter regulation, but at a cost of more gas being exhausted.

48 ID_MIN_EXHAUST

This is the minimum value for the exhaust pulse width modulator. The pulse width modulator's value ranges from 0 to 250. This variable, along with variable #47 (ID_MIN_INLET), sets the deadband for the system. This variable is solenoid dependent and typically has a value close to 10. Larger values can give tighter regulation, but at a cost of more gas being exhausted.

65 ID_PWM_VALUE

This is the value which controls the pulse width modulators for the solenoids. Positive values represent the inlet solenoid opening and negative values are for the exhaust solenoid. A value of +/-250 represents a 100% duty cycle (full on).

121 ID_SUSPEND

This is the state of the Suspend Mode input signal. When suspend mode is activated (1 => Activated) the inlet and exhaust valves remain fully closed and the PID algorithm is suspended. When it is deactivated (0 => Deactivated) the control returns to normal operation.

ER5000 Gain/Offset Variables

39 ID_GAIN

This is the gain value. This value, in conjunction with the offset stored in variable #40 (ID_OSET) is used to form the feedback signal. See variable #44 (ID_FEEDBACK):

feedback = gain * compensated_reading + offset

- 0x0200 => 1/8 (.2% adjustability)
- 0x1000 => 1 (.025% adjustability)
- 0x8000 => 8 (.003% adjustability)

40 ID_OSET

This is the offset value. This value, in conjunction with the gain stored in variable #39 (ID_GAIN) is used to form the feedback signal. See variable #44 (ID_FEEDBACK):

feedback = gain * compensated_reading + offset

- 0x0000 => -1/2 FS
- 0x0fff => +1/2 FS



ER5000 — Internal Variables

ER5000 Control Limit Variables

64 ID_PWM_CONTROL_LIMIT

This variable sets the condition of the controller if any of the programmed limits are exceeded. Normally, the unit will be set up to open the exhaust and close the inlet valve if a limit is exceeded.

NOTE When shipped from the factory the limits are set to their outer boundaries (disabled). The unit will automatically remove itself from the control limit condition when the limit is no longer exceeded.

- 0 => IN_CLOSED_EX_CLOSED
- 1 => IN_OPEN_EX_CLOSED
- 2 => IN_CLOSED_EX_OPEN
- 3 => IN_OPEN_EX_OPEN

Control Limits for Specified Signals

These variables are the minimum and maximum values allowed for a given signal that is permissible before tripping a limit and causing the unit to go into the specified Control Limit Condition.

Table 28: Control Limits for Specified Signals

Minimum/Maximum	Limited Signal
54 – ID_MIN_AD_SETPOINT 55 – ID_MAX_AD_SETPOINT	1 – ID_AD_SETPOINT
56 – ID_MIN_COMPENSATED_INTERNAL_SENSOR 57 – ID_MAX_COMPENSATED_INTERNAL_SENSOR	6 – ID_COMPENSATED_INTERNAL_SENSOR
58 – ID_MIN_COMPENSATED_EXTERNAL_SENSOR 59 – ID_MAX_COMPENSATED_EXTERNAL_SENSOR	7 – ID_COMPENSATED_EXTERNAL_SENSOR
60 – ID_MIN_INNER_ACTUAL_ERROR 61 – ID_MAX_INNER_ACTUAL_ERROR	0 – ID_INNER_ACTUAL_ERROR
62 – ID_MIN_OUTER_ACTUAL_ERROR 63 – ID_MAX_OUTER_ACTUAL_ERROR	14 – ID_OUTER_ACTUAL_ERROR

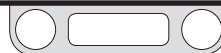



CERTIFICATIONS AND WARRANTY



ER5000 — Certifications and Warranty

Certifications

Copies of all certification documents are available at www.tescom.com. Click on the **CERTIFICATIONS** Quick Link.

CE

Conforms to all known European Union requirements.

EMC DIRECTIVE 2014/30/EU

IEC/EN 61000-6-2: 2005

IEC/EN 61000-6-4: 2007/A1:2011



ER5000 — Certifications and Warranty

Hazardous Locations Special Requirements and Certification for the ER5050

Copies of all certification documents are available at www.tescom.com. Click on the **CERTIFICATIONS** Quick Link.

ATEX



SIRA 15ATEX1295X

Ex db IIB+H2 Txx Gb

Ex tb IIIC T100°C IP66 Db

-20°C ≤ T5 ≤ 60°C

-20°C ≤ T6 ≤ 55°C

EN 60079-0: 2012: All: 2013

EN 60079-1: 2014

EN 60079-31: 2014

IECEX

IECEX CSA 15.0034X

Ex db IIB+H2, Txx Gb

Ex tb IIIC T100°C IP66 Db

-20°C ≤ T5 ≤ 60°C

-20°C ≤ T6 ≤ 55°C

IEC 60079-0: 2011

IEC 60079-1: 2014

IEC 60079-31: 2014

cCSAus

MC-Cert #: 155335-70013318

Class I, DIV. 1, Groups B, C, & D

Class II, DIV. 1, Groups E, F, & G

Class III

Ex d IIB + H2 Txx Gb

Ex tb IIIC T100°C Db

Zone 1, AEx d IIB+H2 Txx

Zone 21, AEx tb IIIC T100°C

-20°C ≤ T5 ≤ 60°C

-20°C ≤ T6 ≤ 55°C

CSA Std. C22.2 No. 30-M1986

UL1203: 5th Edition

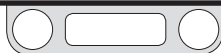

ER5000 — Certifications and Warranty

Hazardous Locations Special Requirements and Certification for the ER5050

Copies of all certification documents are available at www.tescom.com. Click on the **CERTIFICATIONS** Quick Link.

CE

Conforms to all known European Union requirements.

EMC DIRECTIVE 2014/30/EU

IEC/EN 61000-6-2: 2005

IEC/EN 61000-6-4: 2007/A1:2011

FM

Is not certified but conforms to FM Standards. FM Class 3600-1998 & FM Class 3615-2006

SPECIAL CONDITIONS FOR SAFE USE:

- Make sure everything is properly assembled before powering.
 - Do not open when an explosive atmosphere is present.
 - Installation to be in accordance with the latest edition of National Electrical Code.
 - The cable and conduit entry devices shall be certified flame proof types, suitable for the conditions of use and correctly installed.
 - Unused conduit entry must be closed with suitable blanking element.
 - Seal conduit entry within 18 inches.
 - Rated for 20.5 to 28.5 VDC, 340 mAmps.
 - Max working pressure: 110 PSIG
- $-20^{\circ}\text{C} \leq T_{\text{amb}} \leq 60^{\circ}\text{C}$ for T5
 - $-20^{\circ}\text{C} \leq T_{\text{amb}} \leq 55^{\circ}\text{C}$ for T6
 - Thread entry sizes are 1/8" - 27 NPT and 1/2" - 14 NPT. Reference page 18 for locations.
 - The user/installer shall not remove any of the three, 1/8"-27 NPT plugs that are fitted into the base of the enclosure as this will invalidate the Hazardous Location Certification. Reference page 18 for locations.
 - All cable, cable glands, and conductors need >85°C rating.
 - For dust applications, avoid installations that could cause electrostatic build-up on coated surfaces and only clean coated surfaces with a damp cloth.



ER5000 — Certifications and Warranty

LIMITED WARRANTY

TESCOM™ Corporation (“Seller”) warrants that the licensed firmware embodied in the goods will execute the programming instructions provided by Seller and that the goods manufactured or services provided by Seller will be free from defects in materials or workmanship under normal use and care until the expiration of the applicable warranty period. Goods are warranted for twelve (12) months from the date of initial installation or eighteen (18) months from the date of shipment by Seller, whichever period expires first. Consumables and services are warranted for a period of 90 days from the date of shipment or completion of the services. Products purchased by Seller from a third party for resale to Buyer (“Resale Products”) shall carry only the warranty extended by the original manufacturer. Buyer agrees that Seller has no liability for Resale Products beyond making a reasonable commercial effort to arrange for procurement and shipping of the Resale Products. If buyer discovers any warranty defects and notifies Seller thereof in writing during the applicable warranty period, Seller shall, at its option, correct any errors that are found by Seller in the firmware of services or repair or replace F.O.B. point of manufacture that portion of the goods or firmware found by Seller to be defective or refund the purchase price of the defective portion of the goods/services. All replacements or repairs necessitated by inadequate maintenance, normal wear and usage, unsuitable power sources or environmental conditions, accident, misuse, improper installation, modification, repair, storage or handling or any other cause not the fault of Seller are not covered by this limited warranty and shall be at buyer’s expense. Seller shall not be obligated to pay any costs or charges incurred by buyer or any other party except as may be agreed upon in writing in advance by Seller. All costs of dismantling, reinstallation and freight and the time and expenses of Seller’s

personnel and representatives for site travel and diagnosis under this warranty clause shall be borne by buyer unless accepted in writing by Seller. Goods repaired and parts replaced by Seller during the warranty period shall be in warranty for the remainder of the original warranty period or ninety (90) days, whichever is longer. This limited warranty is the only warranty made by Seller and can be amended only in a writing signed by Seller. THE WARRANTIES AND REMEDIES SET FORTH ABOVE ARE EXCLUSIVE. THERE ARE NO REPRESENTATIONS OR WARRANTIES OF ANY KIND, EXPRESSED OR IMPLIED, AS TO MERCHANTABILITY, FITNESS FOR PARTICULAR PURPOSE OR ANY OTHER MATTER WITH RESPECT TO ANY OF THE GOOD OR SERVICES.





APPENDIX A: SETTING UP THE ERTUNE™ PROGRAM ON WINDOWS 8 PCs



ER5000 — Setting up the ERTune™ Program on Windows 8 PCs

Installing the .NET Framework 3.5

If you are running Windows 8 on your PC, the first time you open the ERTune™ program you may see this message:

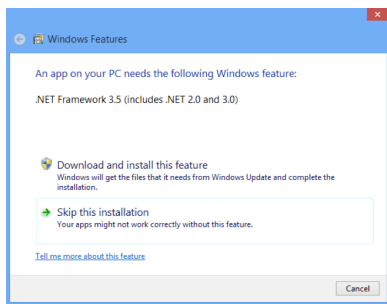

The ERTune™ application was designed using the .NET Framework 3.5, to allow for compatibility with previous Windows operating systems. Windows 8 is built on the .NET Framework 4.5 and does not include .NET Framework 3.5 by default. However, the .NET Framework 3.5 can easily be downloaded and installed.

Note that you will need to be connected to the Internet before you begin. The procedure is as follows:

1. Click Download and install this feature in the message window. Windows will oversee the download and installation.
2. Once the .NET Framework 3.5 has been installed, you will need to verify the feature is turned on.
3. Open the Charms bar by moving the mouse cursor into the upper right or lower right corner of the screen.
4. Select Search.



(continued next page)



ER5000 — Setting up the ERTune™ Program on Windows 8 PCs

5. Type **control panel** into the Search box and click on the Control Panel icon.

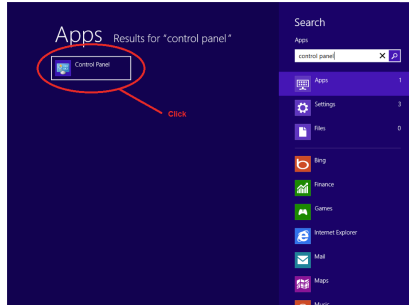

7. Select Programs and Features.

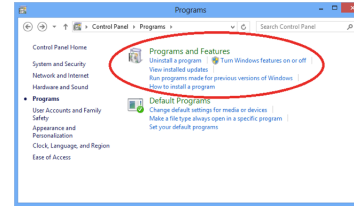

6. Select Programs.

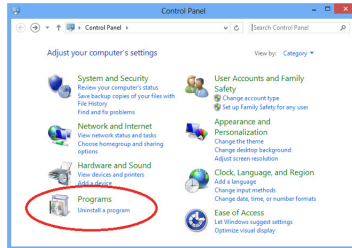

8. Select Turn Windows features on or off.

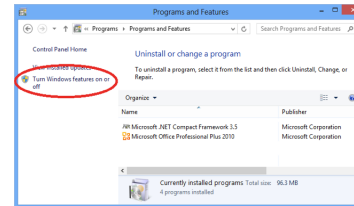

(continued next page)

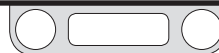

ER5000 — Setting up the ERTune™ Program on Windows 8 PCs

9. Select the .NET Framework 3.5 check box. You do not need to select the child items for Windows Communication Foundation (WCF) HTTP activation unless you are a developer who requires WCF script and handler mapping functionality.

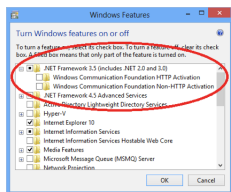

10. Click OK.

Installing the ER5000 Device Driver

When loading the ER5000 USB Serial Port driver onto Windows 8 you may encounter the following error message:

Windows found driver software for your device but encountered an error while attempting to install it.

The third-party INF does not contain digital signature information.

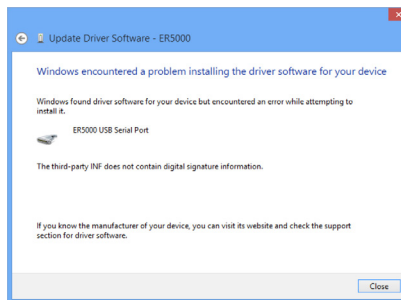

Windows 8 has a Driver Signature Enforcement (DSE) feature. This feature allows the PC administrator or the user who is installing the Windows-based software, to know whether a legitimate publisher has provided the software package.



ER5000 — Setting up the ERTune™ Program on Windows 8 PCs

This feature can be a problem for programs, like ERTune™, which are designed to be compatible with previous versions of Windows. If you get the Error Screen, you will need to temporarily disable the DSE. To accomplish this, do the following:

1. Open the Charms Bar and select Settings.

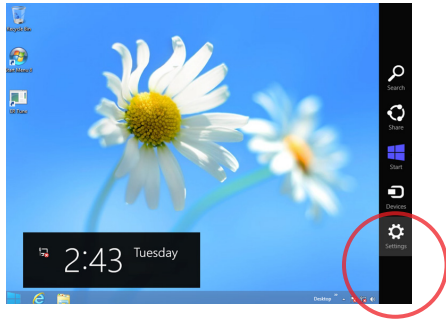

2. Select Change PC settings.

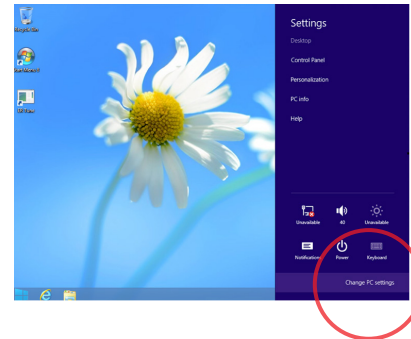

3. Select General, scroll down to Advanced startup and click Restart now.

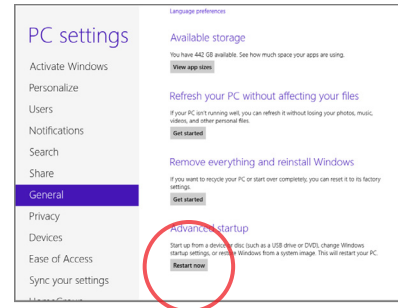

(continued next page)



ER5000 — Setting up the ERTune™ Program on Windows 8 PCs

4. After Windows has restarted, the Choose an option window appears. Select Troubleshoot.

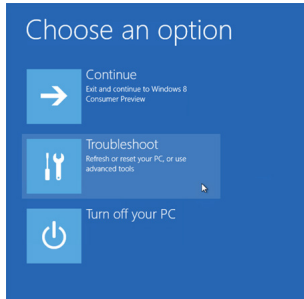

5. Select Advanced options.

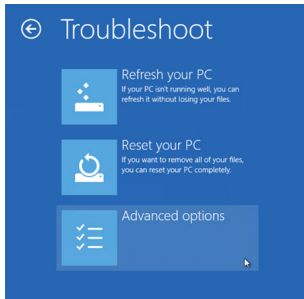

6. Select Windows Startup Settings.

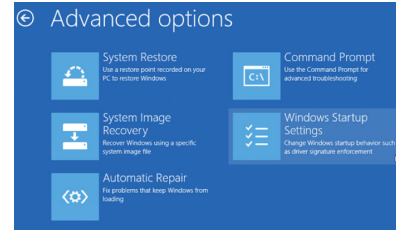

7. Click Restart.



(continued next page)



ER5000 — Setting up the ERTune™ Program on Windows 8 PCs

8. After the operating system has rebooted, the Startup Settings window appears. Press the F7 key to disable the Driver Signature Enforcement feature.

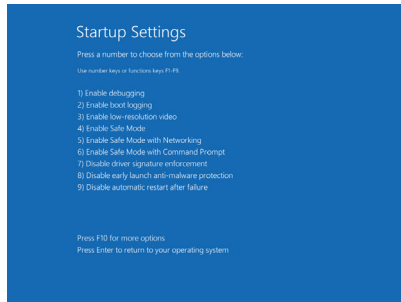

9. Windows 8 will restart. The Driver Signature Enforcement will be disabled until the next reboot.



Emerson

Americas

Emerson
TESCOM
12616 Industrial Blvd.
Elk River, MN 55359
United States

T +1 800 447 1250

 tescom_web@emerson.com

 <https://www.emerson.com>

 [LinkedIn.com/company/emerson](https://www.linkedin.com/company/emerson)

Americas

Emerson
TESCOM
5801 East Harrison
Harlingen, TX 78550
United States

T +1 800 447 1250

Americas

Emerson
TESCOM
Circuito Del Progreso 27
Building 3
Parque Industrial Progreso
Mexicali, BC 21190
México

T +52 686 559 1500

Europe

Emerson
TESCOM
An der Trave 23-25
23923 Selmsdorf
Germany

T + 49 38823 31 284

Asia Pacific

Emerson
TESCOM
Building 40B-2
1006 Jin Min Road
Shanghai Pu Dong District
Shanghai 201206, China

T +86 21 2892 9000 (China)
T +65 6777 8211 (Singapore)

DOPSM2064X012 Rev. AD (02/2024)

The Emerson logo is a trademark and service mark of Emerson Electric Co. TESCOM is a registered trademark.
All other marks are the property of their respective owners. © 2019 Emerson Electric Co. All rights reserved.



CONSIDER IT SOLVED.™