

Series 2000HP High Pressure Pneumatic Actuator



When communicating with EIM for replacement parts or for technical questions, we MUST have actuator nameplate information, including Job, Serial, and Model numbers. This allows us to check records of EIM equipment furnished.

When ordering parts, specify repair part by EIM part number and description from drawings furnished with actuator.



Table of Contents

Section 1:	Introduction	1
Section 2:	Storage Instructions	3
Section 3:	Product Data	4
Section 4:	Lubrication and Maintenance	5
Section 5:	Component Identification	7
Section 6:	Mounting Dimensions	8
Section 7:	Assembly to Valve	9
7.1	Multi-Turn Valve Stem Nut Installation	9
7.2	Lockpin Installation	10
7.3	Thrust Spool Installation (Multi-Turn)	10
7.4	Spline Bushing (Quarter-Turn)	10
7.5	Quarter Turn Gearbox Stop Setting Procedure.....	11
Section 8:	Pneumatic Hookup	12
Section 9:	Travel and Torque Limits	15
9.1	General Information	15
Section 10:	Setting Travel Limit Valves	17
Section 11:	Setting Torque Limit Valves	
11.1	Opening Torque	19
11.2	Closing Torque	20
Section 12:	Optional Electric Limits	21
12.1	General Information	21
12.2	Standard Wiring Diagram.....	22
Section 13:	Typical HP Control Package	23
Section 14:	Typical Control Diagram	24

Section 15: Permco Gas Motor	26
15.1 Installation	26
15.2 Lubrication.....	26
15.3 General Information.....	26
15.4 Servicing	27
Section 16: Troubleshooting	28

Section 1: Introduction

This installation and operation manual explains how to install, operate, and maintain the 2000HP valve actuator.

Carefully follow the instructions in this manual and make sure you install the actuator correctly and according to your requirements.

Safety notices in this manual detail precautions the user must take to reduce the risk of personal injury and damage to the equipment. The user must read these instructions in their entirety. Failure to observe these safety notices could result in serious bodily injury, damage to the equipment, voiding of the warranty, or create operational difficulty.

Safety notices are presented as follows:

⚠ WARNING:

Alerts user of potential danger; failure to follow the warning notice could result in serious personal injury or death.

⚠ CAUTION:

Identifies precautions the user must take to avoid personal injury or equipment damage.

NOTE:

Highlights information critical to the user's understanding of the 2000HP valve actuator installation or operation.

⚠ WARNING:

Read this manual in its entirety before installing, operating, or performing maintenance on the 2000HP actuator.

⚠ WARNING:

Use caution when working on, with, or around valves and actuators. High pressures, forces, voltages and flammable media can be present.

⚠ WARNING:

Failure to follow instructions for proper electrical wiring, storage, setup, and maintenance may cause serious injury, damage equipment, or void warranty.

⚠ WARNING:

If the actuator is being installed within a hazardous area, take into account that:

- **Improper installation in hazardous areas can cause an explosion.**
 - **Assembly, disassembly and maintenance are only allowed at the actuator when, at the time of the activity, an explosive mixture is not present.**
-

Section 2: Storage Instructions

If your actuator cannot be installed immediately, the following procedures are to be followed. This will ensure optimum performance from your 2000HP actuator.

Failure to comply with recommended procedures could lead to actuator malfunction and will void the warranty.

The 2000HP actuator is an inherently weatherproof unit when shipped from the factory, providing that all compartment covers and entry plugs remain intact. The actuator should be immediately stored in a clean, dry warehouse, free from vibration and rapid temperature changes, until it can be installed and commissioned.

If the actuator must be stored outside, it should be stored off of the ground, at an elevation sufficient to prevent it from being immersed in water or buried in snow, and covered to prevent damage from site debris.

If not attached to a valve, the preferred orientation is with the motor and control compartment horizontal.

If the actuator is mounted on a valve and the valve stem protrudes from the unit, a suitable stem protector must be installed to prevent drive sleeve corrosion. Stem protectors may be purchased from your local EIM distributor.

⚠ CAUTION:

Condensation or moisture that enters the actuator can damage internal components, which may ultimately result in failures.

- (1) Ensure integrity of gaskets and O-rings.
- (2) Seal all conduit openings, whether used or not.
- (3) Replace any plastic conduit plugs with pipe plugs appropriate for the application.
- (4) Place a packet of dessicant in the control housing to absorb excessive moisture.

For storage procedures exceeding one year, contact your local EIM representative for recommendations.

Contact information is located on the last page of this manual.

Section 3: Product Data

The EIM 2000HP pneumatic actuator from Emerson is a multi-turn air driven actuator that is perfect for applications using linear stem, rising stem or rotating stem valves. It can be powered by air, nitrogen, or natural gas at pressures between 400 and 1480 psi. Manual controls and/or a number of remote pneumatic or electric control options can be provided as shown in the table below.

Table 1. Standard Control Diagrams

Type	Description	Diagram
Manual	No Controls	PD-200
	Local 2-Way	PD-201
Pneumatic	Fail Close	PD-202
	Fail Open	PD-203
	Double Acting	PD-204
Electric	Fail Close	PD-205
	Fail Open	PD-206
	Double Acting	PD-207

There is a five digit alpha-numeric code used to describe basic actuator features for computer assisted order entry. This number appears on the actuator nameplate affixed to the actuator gear housing. The most significant designators for a sample 2TLG-AF actuator are shown below.

2	T	L	G	-	A	F
Frame Size	Motor Size	Motor Gears	Worm Gears		Control System	Special Services
1 = 1000	T = 1500/1.0" (25mm)				A = No controls	
2 = 2000	U = 1500/1.5" (38mm)				B = Local Manual	
3 = 3000	V = 1500/2.0" (51mm)				C = Remote	
4 = 4000	W = 2500/2.5" (64mm)					

The 2000HP is based on the proven EIM Series 2000 platform and shares many of its distinctive features and benefits such as direct mounting and handwheel operation during power loss or emergency situations.

The four most common frame sizes of EIM actuators, the 1000, 2000, 3000 and 4000, establish the foundation for the 2000HP. Subsequently, most major 2000HP mechanical components are interchangeable with standard EIM electric actuators, which facilitates the acquisition of spare parts.

The control housing is also a shared EIM electric component, resulting in NEMA 4, 4X and IEC IP66 product ratings for the 2000HP. Working temperature range is listed at -20 / +150°F (-29 / +66°C).

Section 4: Lubrication and Maintenance

An annual check of the following items should be made of your EIM 2000HP actuator.

1. Check for any external leaks and tighten fittings appropriately and/or replace failed components.
2. Check for internal component leakage by testing for the presence of air exiting the exhaust port(s) while the actuator is not moving.
3. Open the control housing to inspect and tighten any loose connections.
4. Visually inspect for any mechanical damage. Replace worn or damaged components.
5. Replace any seals that permit oil leakage or water ingress.
6. Lubrication consistency and quantity needs to be checked only after 3000 cycles unless the actuator has been leaking oil or making excessive noise. Fill or replace with recommended fluid if required .

Lubrication – EIM actuator gear housings are factory filled with a high quality lubricant carefully selected to ensure proper performance under specified operating conditions. Refer to EIM JOB SPEC SHEET to identify the lubricant provided. Normal operation *may not* require lubricant replacement.

Lubricant level in the gear housing should be maintained at the following quantity. **Do not overfill.**

See “product data” section of this manual for determining frame size.

- **1000 and 2000 Frame Sizes**
 - Oil: 54 oz (1.54 Liters). Oil is recommended for all drive sleeve speeds over 51 RPM.
 - Grease: 3.5 lbs (1.58 Kg.). Grease is adequate for drive sleeve speeds under 51 RPM.
- **3000 Frame Size**
 - Oil: 62 oz (1.83 Liters). Grease is not recommended for use in the 3000 Frame Size
- **4000 Frame Size**
 - Oil: 75 oz (2.21 Liters). Grease is not recommended for use in the 4000 Frame Size.

The following recommended lubricants are manufactured by Schaeffer Manufacturing Company, but may be replaced with equivalent products manufactured by other reputable companies. Lubricant selection must be made based upon ambient temperature and application.

Table 2. Schaeffer Manufacturing Company Lubricants / Temperature for EIM Products

Product	Continuous Operating Range	Part Number
#158 (ISO 68) Low Temp Oil	-65 / +400°F (-54 / 204°C)	3000100228
#267 EIM Std. Oil	-20 / +350°F (-29 / 177°C)	3000100227
#229 EIM Std. Grease	-25 / +350°F (-32 / 177°C)	3000100222
#200 SUG (Special for EIM)	-40 / +400°F (-40 / 204°C)	3000100212
#197 Low Temp, Grease	-60 / +500°F (-51 / 260°C)	3000100219
#271 Food Grade	-15 / +500°F (-26 / 260°C)	3000100216
#276 Food Grade Oil	-15 / +300°F (-26 / 149°C)	3000100218
#286 High Temp	*Na / +900°F (*Na / 482°C)	3000100220
#167 (Gear Oil) 75-140 Wt.	-50 / +350°F (-45 / 177°C)	3000100230
#238 EP 1 Grease	-10 / +350°F (-23 / 177°C)	3000100226

NOTE:

During operation of this actuator, gear housing temperature increase in combination with variations of outdoor temperature may cause a small pressure build-up within the actuator gear box. EIM furnishes Pressure Relief Vent Fitting Part No. 83385 to prevent excessive pressure build-up. Pressure Relief Vent Fitting placement on the actuator can be determined after field location and position of the valve have been determined. Select the highest 1/2NPT vent location of the actuator gear box; remove the 1/2 NPT plug and replace with Part No. 83385.

Section 5: Component Identification

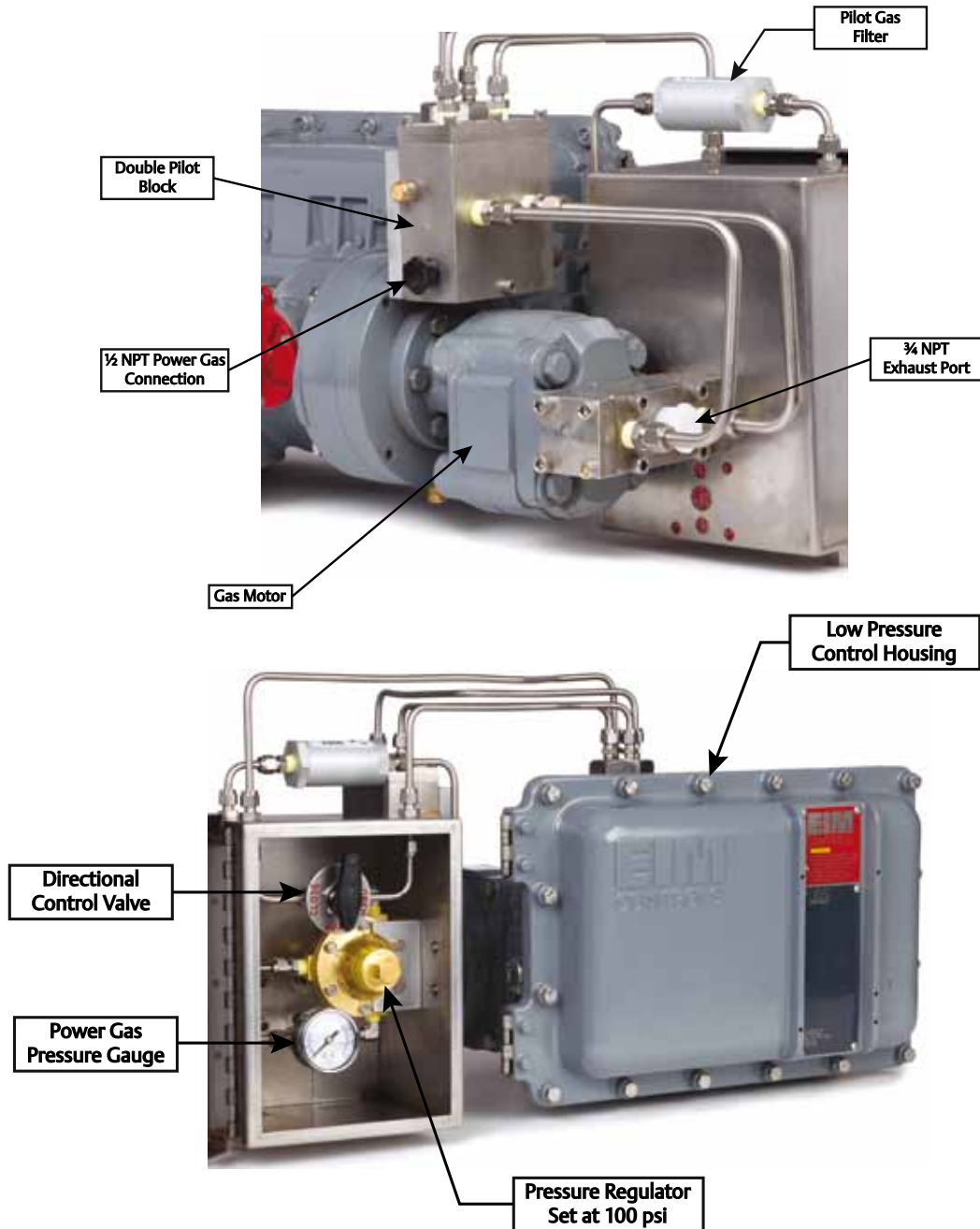

Section 6: Mounting Dimensions

EIM Standard mounting is MSS SP-102 (FA) – Left column

ISO (F) Mounting can be supplied if requested – Right column

FA10/F10

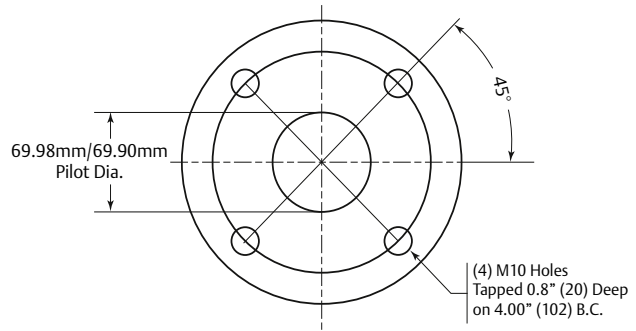
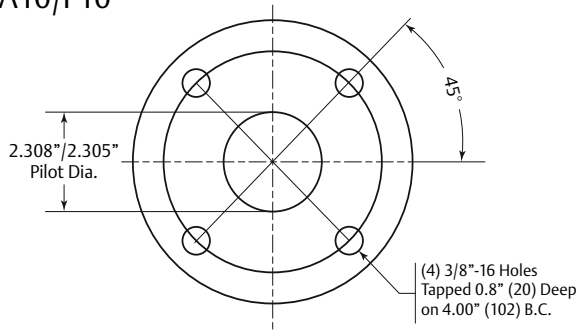

FA14/F14

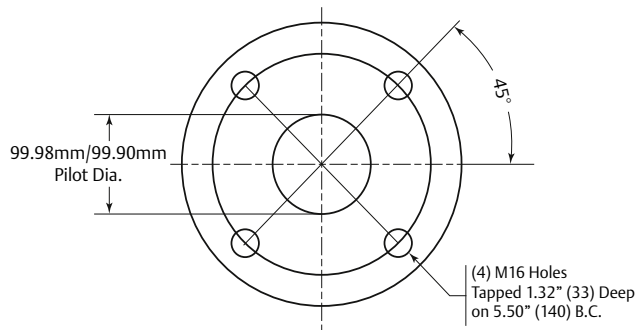
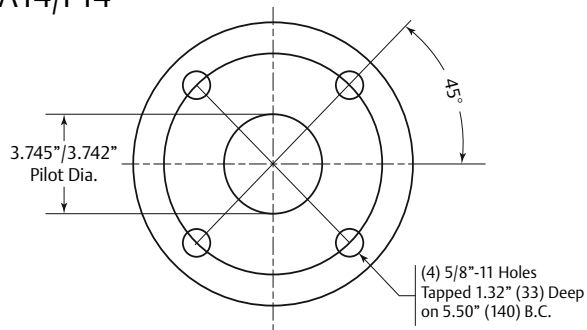

FA16/F16

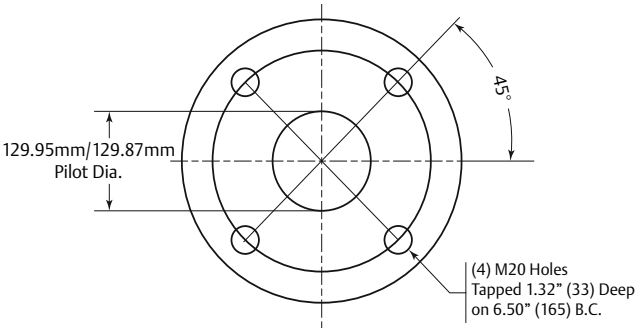
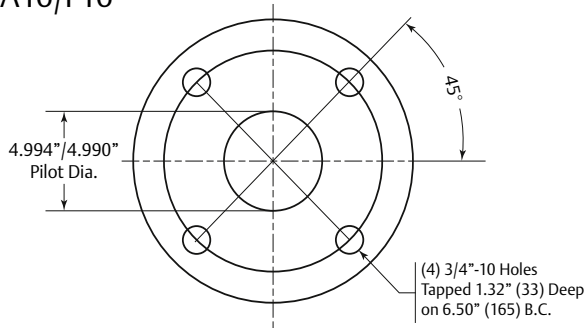

FA25/F25

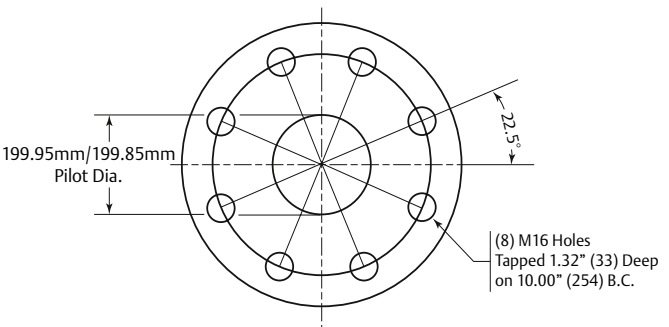
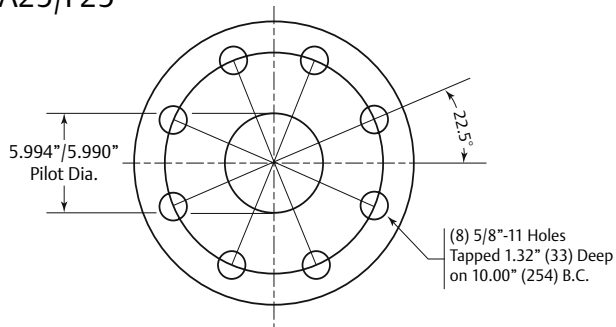

Section 7: Assembly to Valve

7.1 Multi-Turn Valve Stem Nut Installation

Figure 1



1. Unscrew Locknut (55) holding Bronze Stem Nut (54) and remove Stem Nut and Key (52).
2. Lubricate Stem and run Stem Nut (54) down stem to check acme thread fit, then remove Stem Nut and set aside.
3. Lower actuator over stem onto valve flange. After ensuring proper flange mating and valve actuator orientation, insert Grade 5 mounting screws thru valve flange into actuator. Screws must engage a minimum of one full screw diameter into bottom base and be torqued to the following value:
 - 3/8-16 = 50 lbf-ft (M10 = 68 Nm)
 - 5/8-11 = 225 lbf-ft (M16 = 305 Nm)
 - 3/4 -10 = 400 lbf-ft (M20 = 542 Nm)

NOTE:

If EIM supplied adaption, the mounting screws are included. If the adaption to the valve was the responsibility of others, the mounting screws are not furnished by EIM. Screws thru adapter **MUST** engage a minimum of one screw diameter into EIM actuator base.

4. Screw Stem Nut (54) onto valve stem until it enters the Drive Sleeve. Align Nut Key (52) with Drive Sleeve keyway and insert Stem Nut Key (52).
5. Turn handwheel in Open direction, pulling the Stem Nut into Drive Sleeve until it bottoms out (valve will begin to open).
6. Place Locknut (55) over Valve Stem and screw into place firmly against top of Stem Nut (54). Tighten Locknut by tapping ears with brass drift.

⚠ CAUTION:

Locknut must be screwed very tightly against stem nut.

7.2 Lockpin Installation

1. Using a number 30 (.1285) drill; drill a hole 3/4 inch deep into the Drive Sleeve assembly threads for the Locknut Lockpin(56). Use groove in Stem Nut Locknut threads as a guide.
2. Install Locknut Lockpin (56) into drilled hole to prevent the Stem Nut Locknut from working loose and turning.

NOTE:

When installing, the Lock-nut Lockpin should extend 1/4 inch above the Drive Sleeve Assy to allow for easy removal.

7.3 Thrust Spool Installation (Multi-Turn)

1. Locate Thrust Mounting bolts.
2. Remove the eight mounting bolts and separate the Spool from the actuator.
3. Position the Spool over the valve stem. Thread the Spool onto the valve stem until it meets the valve plate.
4. Bolt and secure Spool onto valve.
5. Position actuator above Spool. Lower actuator onto Spool while manually rotating the unit until ears on the stem nut and ears on main Drive Sleeve mesh.
6. Grease flange face before securing unit to Spool.
7. Re-install thrust plate mounting bolts. Tighten to proper torque.

NOTE:

Reverse procedure if the stem nut needs to be replaced. Actuator does not need to be returned to factory for this procedure.

7.4 Spline Bushing (Quarter-Turn)

EIM removable Spline Bushing allows easy adaption to valve shaft diameter and key. Actuator may be rotated with respect to the valve shaft for unexpected or awkward field installations.

1. Move valve to full Open or Close.
2. Place Splined Bushing on valve shaft with key and tighten set screw.
3. Using the handwheel on actuator, move the Gear position indicator arrow to full Open or full Close (duplicating the position in Step 1).
4. Position actuator so the Splined Bore is correctly aligned with the Splined Bushing on stem shaft.
5. Lower the actuator onto the shaft until the flange faces properly mate. Secure with screws thru the adapter flange into the base of the actuator.

7.5 Quarter Turn Gearbox Stop Setting Procedure

Built-in mechanical stops are provided in the gearbox to prevent operation beyond total valve travel of 90° ($\pm 6^\circ$).

End of travel stops are independently adjusted, locked in place and sealed.

Figure 2

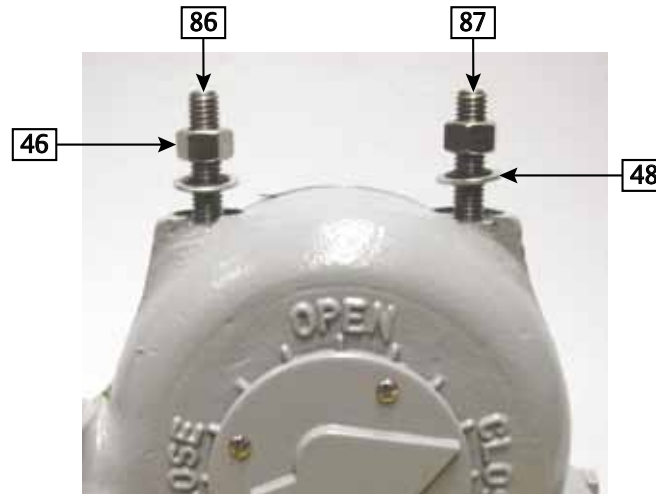

Loosen both LOCKNUTS (46) and back out two STOPBOLTS (86 & 87) to allow valve to close and open fully. Ensure Travel Limit Valves have been properly adjusted (see appropriate section of this manual), and then proceed as follows:

1. Run actuator pneumatically to full closed position.
2. Screw CLOSE STOPBOLT (86) in until it seats, then back off 1/2 TURN. Install WASHER (48) and tighten LOCKNUT (46).
3. Run actuator pneumatically to full open position.
4. Screw OPEN STOPBOLT (87) in until it seats, then back off 1/2 TURN. Install WASHER (48) and tighten LOCKNUT (46).

⚠ CAUTION:

Do not set Actuator Travel Limit valves to drive into mechanical stops. Damage can occur if actuator is allowed to repeatedly stall into end stops.

Section 8: Pneumatic Hookup

1. Upon completion of mounting the actuator to the valve per previous instructions, move the valve position to mid-stroke with the actuator's Handwheel. This will provide sufficient time to stop actuator operation in case of incorrect pneumatic connection(s).
2. Identify a means of removing power from the actuator during hook up and verify functionality.
3. Be sure no erroneous electrical or pneumatic remote signal can be received that would cause the actuator to initiate operation.
4. Each pneumatic actuator is supplied with a control valve, sized to deliver an air volume at the necessary flow rate to achieve design performance for each actuator. The following criteria should be used when selecting your pneumatic system. The air motor size (*) can be found on the unit ID (serial number) tag.

Table 3. Motor Pressure Consumption

Motor	NPT	Pressure	SCFM
*T	1/2"	1480	220
*U	1/2"	1480	240
*V	1/2"	1480	260
*W	1/2"	1480	300

Consumption at a lower pressure is proportional to the data shown. Consideration must be given to your piping system. At 1480 psi supply, a minimum of schedule 80 piping, or tubing with the appropriate pressure rating is required. Piping size to the actuator must be at least 1/2 NPT and connected to a larger header as close to the actuator as possible.

NOTE:

Do not hang pipe loads on the actuator. Use external support or flexible connections to the actuator.

5. Installation of a filter and lubricator in the gas line leading to the pneumatic motor is required. The filter and lubricator **MUST** have connections equal or greater than 1/2 NPT and should be mounted in a horizontal pipe run as near as possible to the actuator.

⚠ CAUTION:

ALL components MUST be rated for operation at 1480 psi minimum .

The filter MUST have a 90-120 micron rating and be capable of flowing the correct volume (SCFM) of gas shown on the chart in Table 3.

EIM manufactures a filter designed specifically for this application.

Figure 3 EIM Part Number 100088



6. Installation of a lubricator in the gas line leading to the pneumatic motor is also required. The automatic lubricator MUST be capable of being adjusted to supply one drop of oil for every 20-40 SCFM of gas being used by the actuator.

For example, a "T" motor running for one minute would require a minimum of six drops of oil from the lubricator. Reference the chart in column #1 for gas flow data.

EIM manufactures a lubricator assembly designed specifically for this application.

Figure 4 EIM Part Number 100009



7. A lubricant is required for all internal moving parts of the pneumatic motor. This is intended to reduce wear and prevent rust. Brand name oils are suitable if they are mineral and wax-free base & aniline point in the range of 200°-220° F. Oils must be thin enough to atomize in the lubricator. This should be in the range of Group D Turbine Light with a viscosity of 32 at 100°F. Listed below is a representative group of suitable light oils that may be considered for use.
- Chevron - GTS Oil 32
 - Exxon - Teresstic T32
 - Mobil - Light
 - Shell - Turbo 32
 - Texaco - Capella 32 WF
 - Para/Synthetic Lubricant - Southeast Oil & Grease Co. AL-32
-

NOTE:

Do not use penetrating oils or detergent type oils as they will damage seals and thicken in cold weather.

Any temperature below 32°F may require the addition of small amounts of pure ethylene glycol into the air system to prevent freezing. Do not concede the volume of oil normally used.

⚠ CAUTION:

Use of the product on any power medium other than compressed air, nitrogen, or natural gas may establish a potential hazard.

NOTE:

This product, as well as similar devices such as cylinders, solenoid valves, ESD valves, compressor, etc. emit to atmosphere in their normal operational mode. Confer with established codes and safety regulations.

Section 9: Travel and Torque Limits

9.1 General Information

⚠ CAUTION:

All components inside the control enclosure are low pressure devices. The pipeline gas pressure to the control is run through a pressure regulator to reduce the operating pressure to 100 psig (6.9 bar). Do not introduce pressure higher than 100 psig (6.9 bar) into any components inside the control enclosure.

All Series 2000HP pneumatic actuators are provided with 3-way pneumatic travel limit valves (LVO and LVC). They are activated at each end of stroke to neutralize the control and stop the actuator in the proper position.

See figure 5 for location in control housing.

Series 2000HP actuators are also provided with 3-way pneumatic torque limit valves (TVO and TVC). They are activated when an over-torque condition is detected in either the opening or closing direction and will neutralize the control in order to prevent valve damage. They may also be set to provide the correct amount of torque for torque seated valves.

See figure 5 for location in control housing.

Figure 5

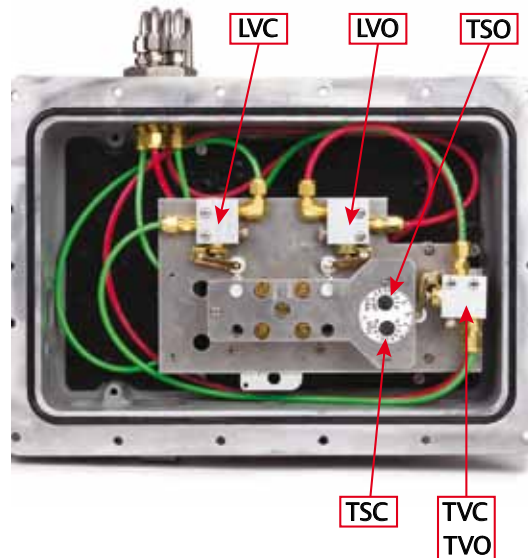

NOTE:

All position and torque limit valves must be set according to the instructions on the following pages of this manual after mounting the actuator to the valve.

The control assembly can also be fitted with auxiliary pneumatic limit valves for remote indication or other logic circuits as desired. These valves are mounted on top of the travel limit valves (LVO - LVC) and are actuated by the same cams as the travel limit valves. Consequently they cannot be adjusted to operate at any valve position other than full open and full closed with the travel limits. These valves can be used as 3-way normally closed, 3-way normally open or selector valves depending on port selection.

Pneumatic valve details:

- Maximum operating pressure rating - 125 psig
- Flow coefficient – 0.1 (20 CFM at 125 psig)
- Port size – 1/8 NPT
- With the roller actuator out (extended), the NO port is Open to Cylinder. This blocks the NC port on the valve.
- When the roller actuator depressed, the NC port is open to Cylinder and the NO port is blocked.

NOTE:

Optional electrical contacts are also available as needed. See pages 21 and 22 of this manual for electrical limit switch information and wiring diagram. It must also be recognized that auxiliary pneumatic limit valves and electrical limit switches cannot both be supplied on the same unit.

Section 10: Setting Travel Limit Valves

Before setting limits it must be noted that actuators ordered specifically for torque-seated valve applications are assembled at the factory without tubing on the closing side limit valve. The close side limit valve is physically installed but the tubing bypasses it and runs directly to the torque limit.

1. **Determine full-open valve position**

Open the valve completely using the handwheel. Observe the rotational direction of the adjusting shaft (1) during opening. When the valve is fully open, close several turns (clockwise) to prevent overtravel.

2. **Disengage drive pinion**

Push the spring loaded shaft (2) down and rotate it 90° to the captured position. This disengages the gear drive from the G/L pinion. The shaft (1) will now rotate freely.

3. **Rotate adjustment shaft**

Observe position of limit valve roller cam for one of two positions.

- Position One - if the cam has not actuated the LVO valve, rotate the adjusting shaft (1) in the same direction noted in step one until the rotating cam actuates the limit valve.
- Position Two – if the cam has actuated the LVO valve, rotate the adjusting shaft (1) in the opposite direction until the rotating cam actuates the limit valve.

NOTE:

Limit valves are actuated when the cam is pointing at the center of the limit valve roller.

NOTE:

Many turns maybe required to set travel limits. It may be convenient to use a reversible variable speed drill to rotate the adjusting shafts instead of a screwdriver.

4. **Re-engage drive pinion**

Rotate the spring-loaded shaft (2) 90°. The shaft will rise when locked in place.

5. **Important**

Lightly jiggle all adjusting shafts back and forth with a screwdriver to ensure correct engagement: shafts should not turn when locked in place.

6. **Determine full-close valve position**

Close the valve completely using the handwheel. Observe rotational direction of adjusting shaft (3) during closing. Once the valve is closed, open it several turns (counterclockwise) to prevent overtravel.

Repeat steps 2 thru 5 for LVC limit valve.

Figure 6

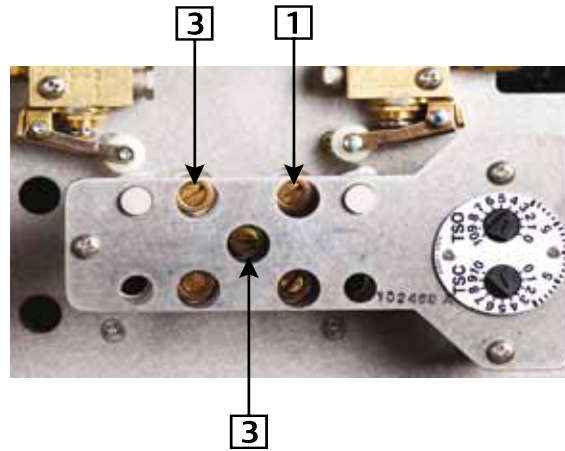

Section 11: Setting Torque Limit Valves

Torque limit valves prevent mechanical overload in the Closed (TVC) and Open (TVO) positions. The torque limit valves are mounted in a stacked configuration. The top torque limit valve (TVO) controls the actuator opening torque and the bottom limit valve (TVC) controls the actuator closing torque.

Refer to the EIM Job Specification Sheet supplied with each actuator to review the customer-provided valve torque requirement shown at the top of the sheet. The bottom of the specification sheet shows numerous torque switch dial settings relative to output torque trip point limits. All actuators are shipped from the factory at minimum torque dial setting unless otherwise specified by customer.

NOTE:

The customer supplied torque values on EIM Job Specification Sheets already includes a safety factor.

NOTE:

Closing torque limits for torque-seated valve applications are factory set.

11.1 Opening Torque

Using the handwheel, open the valve completely while observing the Torque Dial rotation for a reference operating point.

Figure 7

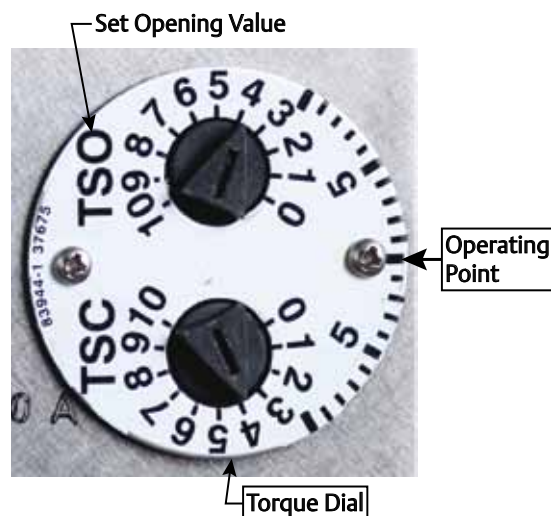

Refer to the EIM Job Specification Sheet for additional suggested setpoints. Determine appropriate setpoint and press down on the TSO dial indicator approximately 1/16" with a flat blade screwdriver and position the arrow for the desired setting. Release to secure in place.

Partially open the valve and reseal with the Handwheel to ensure the set point is accurate.

11.2 Closing Torque

Using the handwheel, close the valve completely while observing the Torque Dial rotation for a reference operating point.

Figure 8

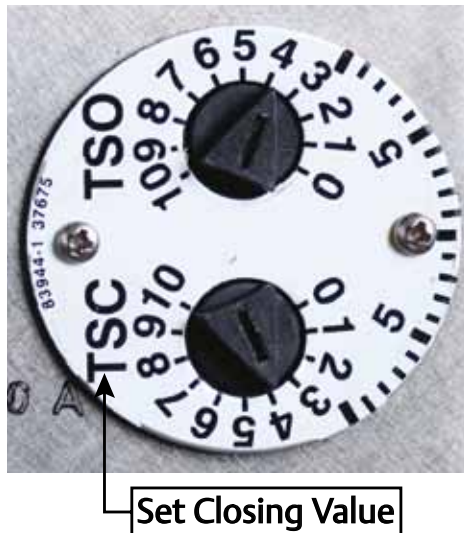

Refer to the EIM Job Specification Sheet for additional suggested setpoints. Determine appropriate setpoint and press down on the TSC dial indicator approximately 1/16" with a flat blade screwdriver and position the arrow for the desired setting. Release to secure in place.

Partially open the valve and reseal with the Handwheel to ensure the set point is accurate.

Section 12: Optional Electric Limits

12.1 General Information

Two optional limit switches are available for Series 2000HP pneumatic actuators, one for open position (LSO) and one for the close position (LSC) – see Figure 9.

The 12 point electrical terminal strip (ETS) for customer connection is mounted on the backplate - see Figure 9.

Figure 9

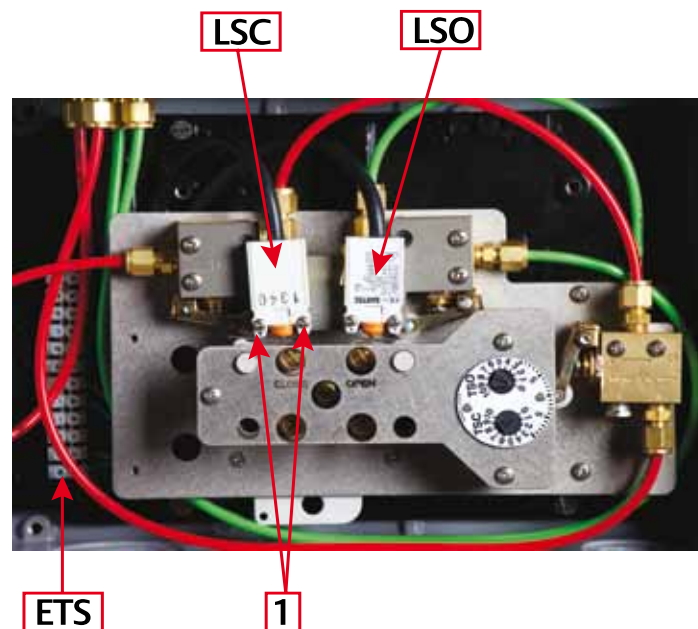

Limit switches LSO and LSC are mounted to a bracket located on top of the limit valves. They are actuated by the same cam that actuates the limit valves and may be independently adjusted by loosening the mounting screws (1) and repositioning the switch in the slotted mounting bracket.

NOTE:

Electrical limit switches cannot be installed if auxiliary pneumatic limit valves are required.

12.2 Standard Wiring Diagram

Limit switches are supplied with a potted flexible connecting cable containing four wire leads; one blue lead, one black lead, one brown lead and one gray lead. These leads are factory prewired to the terminal strip (ETS) for each end of travel limit – see Figure 10.

Table 4. Rated Switching Capacity

	AC		DC	
	Resistive	Inductive	Resistive	Inductive
400V	3A	2A		
250V	5A	3A	0.4A	0.03A
30V	7A	5A	7A	5A

Figure 10

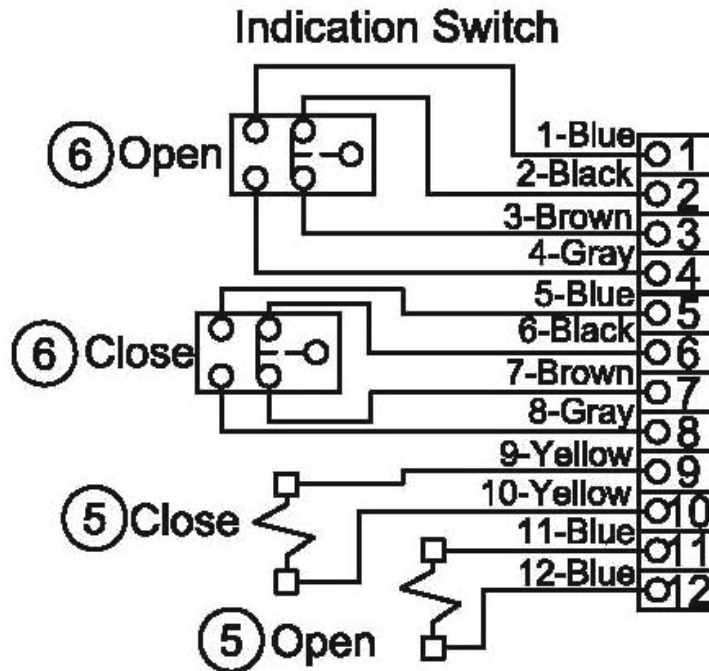

NOTE:

Limit switches are always wired to terminals #1 through #8 as shown, even when solenoids are not provided.

Section 13: Typical HP Control Package

REV	REV	DESCRIPTION	DATE	APPRO
B	15126	Updated to Emerson Template	JUL 9/7/11	

ITEM QTY.	DESCRIPTION	PART NO.	
1	1	LIMIT SWITCH PLATE	102366
2	1	TOP PLATE	102460
3	4	HUMPHREY MINI LIMIT VALVE ASSY.	100077
4	3	SPACER POST, TOP PLATE	102136
5	2	SPACER POST, LIMIT SWITCH PLATE	102371
6	1	TORQUE LIMIT ASSEMBLY	SEE BOM
7	1	TORQUE SHAFT BUSHING	102140
8	1	TORQUE SHAFT	102171
9	2	CAM	102462
10	3	ALIGNMENT BAR, #8-32	102369
11	4	NYLON WASHER, 3/8" ID X .06 THK.	4046000032
12	4	PAN HD PHILLIPS SCW, #8-32 X 1" LG.	4042610242
13	10	PAN HD PHILLIPS SCW, #8-32 X 1/2" LG.	4042612119
14	4	FLAT HD PHILLIPS SCW, #8-32 X 1/2" LG.	4042630076
15	10	FITTING, 1/8" NPT X 3/16" SWAGELOCK	111300-1-2-B
16	2	ELBOW, 1/8" NPT X 3/16" SWAGELOCK	111300-2-2-B
17	1	1-1/2" PORTED NUT, 4 PORTS	102362
18	4	FITTING, 1/8" NPT X 1/4" SWAGELOCK	111400-1-2-SS
19	4	VENT, 1/8" NPT	4300090011
20	1	SPACER BLOCK	102459
21	2	PAN HD PHILLIPS SCW, #8-32 X 1-3/4" LG.	4042612121

NOTE: ITEM 6 CHANGE TO BLACK TORQUE SWITCH FOR LEFT WORMGEAR

PORTED NUT ASSEMBLY FOR INSTALLATION IN WALL OF CONTROL BOX

OPEN TORQUE
CLOSE TORQUE

EMERSON
Process Management

CONTROLS LAYOUT, LOW PRESSURE, LVO, LVC, TVO, TVC, HUMPHREY VALVES

TITLE: **100013-2**
DATE: 5-5-03
REV: B

THE DOCUMENT CONTAINS CONFIDENTIAL AND TRADE SECRET INFORMATION WHICH IS THE PROPERTY OF EMERSON COMPANY, INC. AND RECEIVED UNDER A LICENSE FROM THE U.S. GOVERNMENT. IT IS TO BE USED ONLY FOR THE PURPOSES AND IN ACCORDANCE WITH THE LICENSE AGREEMENT. IT IS NOT TO BE REPRODUCED, COPIED, OR TRANSMITTED IN ANY FORM OR BY ANY MEANS, WITHOUT EXPRESS WRITTEN PERMISSION OF EMERSON COMPANY, INC. OR THE U.S. GOVERNMENT.

Copyright © 2011, Emerson Process Management Valve Actuation LLC. All Rights Reserved

Section 14: Typical Control Diagram

Example One - Local Manual #PD-201

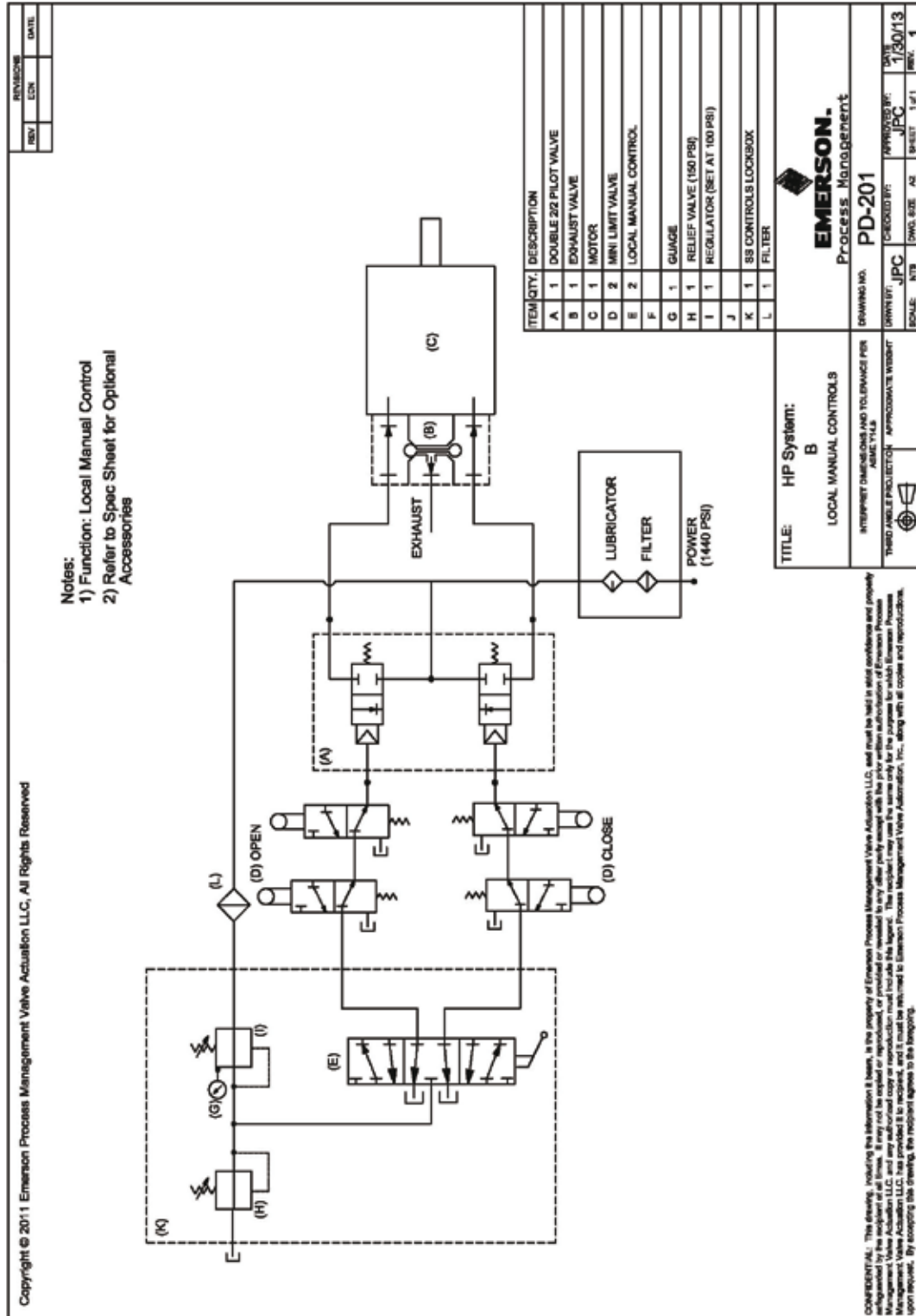

Example Two - Remote Electric Control #PD-207

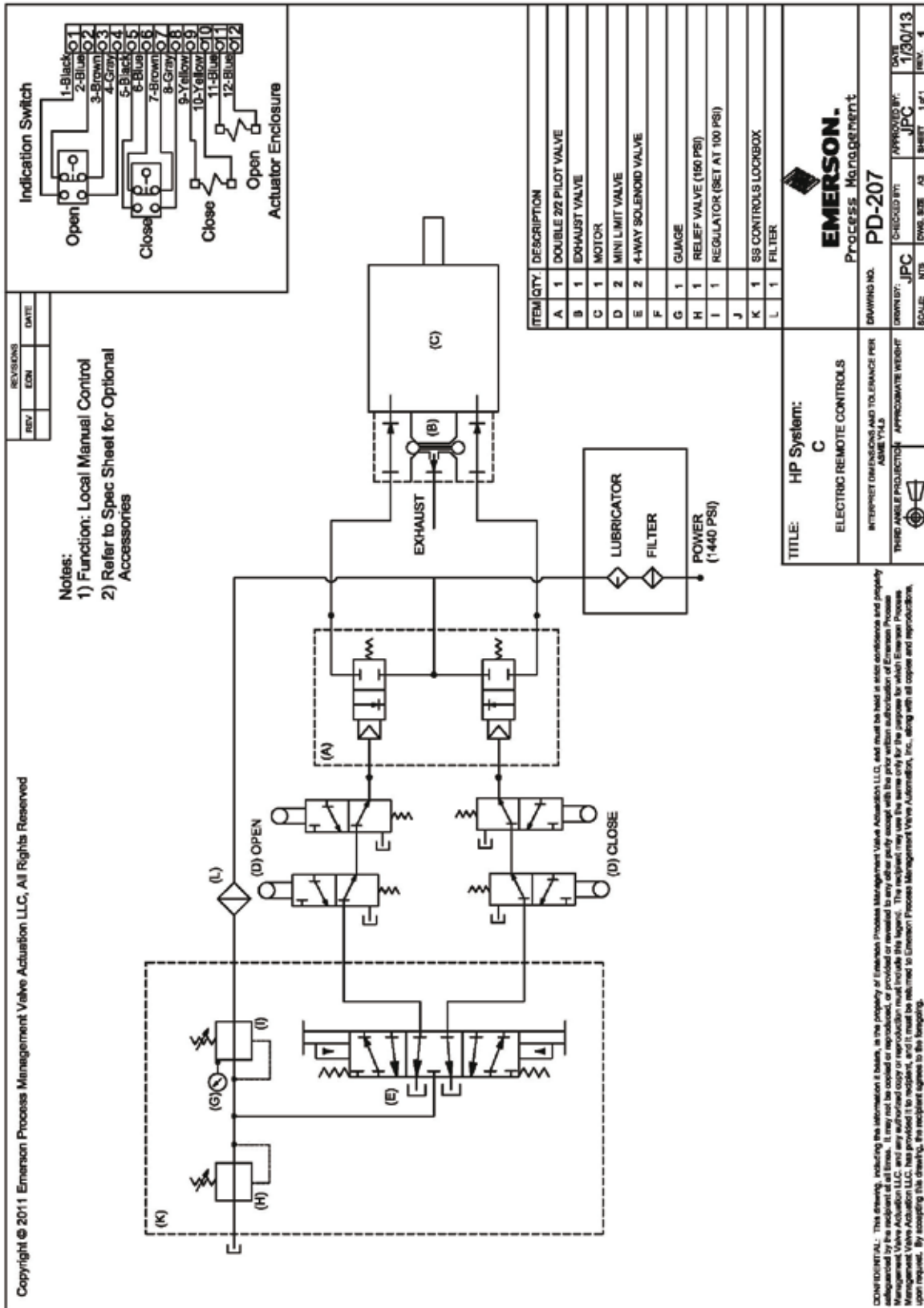

Section 15: Permco Gas Motor

The gas motor supplied is a precision built rotary gear type. Internal components take up their own wear & will last approximately 5,000 to 15,000 hours of use. This depends on motor speed, method of oiling, operating pressure and preventative maintenance practices.

MOTOR SIZES

- T = 1500/1.0" (25mm)
- U = 1500/1.5" (38mm)
- V = 1500/2.0" (51mm)
- W = 2500/2.5" (64mm)

15.1 Installation

Install a moisture trap and filter in the air line ahead of the actuator's air motor. For efficiency of output and speed control, use gas lines the same size or in the next pipe size larger than the intake port of the motor.

The motors are piped up to work equally well in both directions of operation. The control valve makes reversing possible [refer to typical control diagram].

When coupling or connecting the motor to a driven member, avoid any end or side thrust on the motor shaft. Do not hammer on the shaft itself.

15.2 Lubrication

Lubrication is necessary for all internal moving parts and rust prevention. An automatic air line lubricator must be installed in the air line just ahead of the air motor. The lubricator should be adjusted to feed one drop of oil for every 50 – 75 SCFM of air going through the motor. Oil specifications can be found in the Pneumatic Hookup section of this manual.

Excessive moisture in the air line can cause rust formation in the motor and might also cause ice to form in the muffler due to expansion of air through the motor.

The moisture problem can be corrected by installing a moisture separator in the line & by installing an aftercooler between the compressor and air receiver.

15.3 General Information

The air motor is designed to be driven by compressed nitrogen and compressed natural gas. Under no circumstances should it be driven by fluids, particles, solids or any substance mixed with air.

⚠ WARNING:

Do not allow corrosive gases or particulate material to enter the motor. Water vapor, oil-based contaminants, or other liquids must be filtered out.

15.4 Servicing

If the motor is sluggish or inefficient, try flushing with an approved solvent:

- To flush, disconnect air line and muffler, add several teaspoons or spray solvent directly into the motor.
- Rotate the shaft by hand in both directions for a few minutes, reconnect the air line and slowly apply pressure until there is no trace of solvent in exhaust air.
- Flush unit in a well ventilated area.
- Re-lubricate the motor with a squirt of oil in the chamber.



Gas Motor Parts

Section 16: Troubleshooting

⚠ WARNING:

Use caution when working on, with, or around valves and actuators. High pressures, forces, voltages, and flammable media can be present. Turn off electric, if provided.

SYMPTOM	PROBABLE CAUSE	CORRECTION
MOTOR WILL NOT RUN	No power to actuator	Check Air Supply
	Low Gas Motor Pressure – Filter is clogged in power or control circuit or	Clean or replace filter
	Motor Vanes are Worn	Check worn motor vanes
HANDWHEEL HARD TO TURN	Valve stem improperly lubricated	Lubricate with grease
	Actuator lubrication has broken down	Clean out old grease and replace with new
	Valve Packing Gland too tight	Loosen packing gland nuts
	Drive Sleeve Bearing Failure	Replace bearing
	Jammed Valve	Refer to Valve Maintenance
VALVE ONLY OPENS OR CLOSSES PARTIALLY WITH MOTOR	Torque Setting too Low	Check setting & recalibrate
	Limit Improperly Set	Check actuation & reset
TORQUE VALUE IS CORRECTLY SET, BUT ACTUATOR TORQUES OUT IN MID-TRAVEL	Damaged or bent valve stem	Refer to Valve Maintenance
	Valve Packing too Tight	Refer to Valve Maintenance
	Jammed Valve (obstruction in line)	Refer to Valve Maintenance
HANDWHEEL WILL NOT OPERATE VALVE	Handwheel shaft bearing assembly malfunction	Repair or replace
	Sheared gear key or stripped gearing	Replace
	P/S shifter in wrong position or malfunctioning	Shift into proper position Replace parts as required
	Broken Handwheel shaft	Repair or replace
	Broken valve stem or stripped stem nut	Replace as required
MOTOR RUNS BUT WILL NOT OPERATE THE VALVE	Motor Bearing assembly malfunction	Repair/Replace
	Sheared gear key [fastener, pin]	Replace
	Stripped gearing	Replace
	Broken valve stem or stripped stem nut	Repair/Replace
MOISTURE IN CONTROL ENCLOSURE	Leakage through conduit entry	Tighten all conduit plugs
	Enclosure is not correctly sealed	Inspect & replace o-ring
GREASE [OIL] IN CONTROL ENCLOSURE	Pressure relief fitting not installed	Install pressure relief fitting
	Bad Torque Limit or Gear Limit assembly	Replace assembly
	Bad Torque Limit or Gear Limit seal	Replace seal

Contact Us: Emerson Process Management, Valve Automation facilities at your nearest location:

NORTH & SOUTH AMERICA

13840 Pike Road
Missouri City, Texas 77489 USA
T +1 800 679 1561 (Toll Free USA)
T +1 281 499 1561
F +1 281 499 8445
info: missouricity@emerson.com

MIDDLE EAST & AFRICA

P. O. Box 17033
Dubai
United Arab Emirates
T +971 4 811 8100
F +971 4 886 5465
P. O. Box 105958

EUROPE

Asveldweg 11
7556 BR Hengelo (O)
The Netherlands
T +31 74 256 1010
F +31 74 291 0938

Via Montello 71/73
20038 Seregno (Milan)
Italy
T +39 0362 2285 207
F +39 0362 2436 55

ASIA PACIFIC

No. 9 Gul Road
#01-02 Singapore 629361
T +65 6501 4600
F +65 6268 0028

1277 Xin Jin Qiao Road
Jin Qiao Export Processing Zone
Shanghai 201206
P.R.China
T +86 21 2892 9000
F +86 21 2892 9001

Please visit our web site for up to date product data.

www.EmersonProcess.com/EIM.

©2013 Emerson Process Management. All Rights Reserved.

The Emerson logo is a trademark and service mark of Emerson Electric Co. Brand name is a mark of one of the Emerson Process Management family of companies. All other marks are the property of their respective owners.

The contents of this publication are presented for information purposes only, and while effort has been made to ensure their accuracy, they are not to be construed as warranties or guarantees, express or implied, regarding the products or services described herein or their use or applicability. All sales are governed by our terms and conditions, which are available on request. We reserve the right to modify or improve the designs or specifications of our products at anytime without notice.

