

Micro Motion™ Filling Mass Transmitter

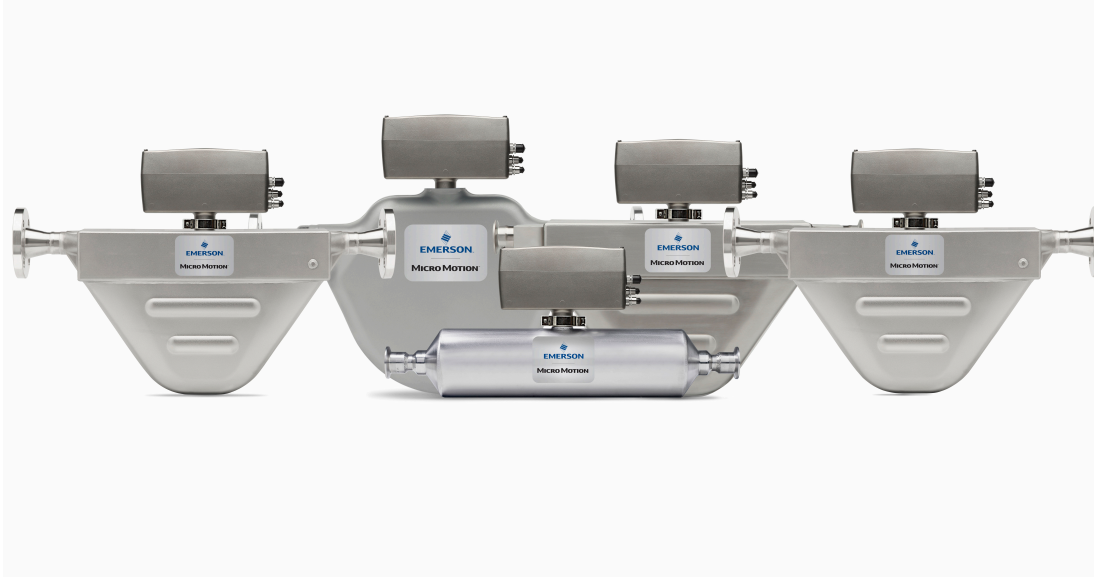

Safety messages

Safety messages are provided throughout this manual to protect personnel and equipment. Read each safety message carefully before proceeding to the next step.

Safety and approval information

This Micro Motion product complies with all applicable European directives when properly installed in accordance with the instructions in this manual. Refer to the EU Declaration of Conformity for directives that apply to this product. The following are available: the EU Declaration of Conformity, with all applicable European directives, and the complete ATEX installation drawings and instructions. In addition, the IECEx installation instructions for installations outside of the European Union and the CSA installation instructions for installations in North America are available at [Emerson.com](https://www.emerson.com) or through your local Micro Motion support center.

Information affixed to equipment that complies with the Pressure Equipment Directive, can be found at [Emerson.com](https://www.emerson.com). For hazardous installations in Europe, refer to standard EN 60079-14 if national standards do not apply.

Other information

Troubleshooting information can be found in the [Configuration Manual](#). Product data sheets and manuals are available from the Micro Motion website at [Emerson.com](https://www.emerson.com).

Return policy

Follow Micro Motion procedures when returning equipment. These procedures ensure legal compliance with government transportation agencies and help provide a safe working environment for Micro Motion employees. If you fail to follow Micro Motion procedures, then Micro Motion will not accept your returned equipment.

Return procedures and forms are available on our web support site at [Emerson.com](https://www.emerson.com), or by calling the Micro Motion Customer Service department.

Contents

| | | |
|-------------------|---|-----------|
| Chapter 1 | Planning..... | 5 |
| | 1.1 Meter components..... | 5 |
| | 1.2 Accessibility for maintenance..... | 5 |
| | 1.3 Discrete Output wiring requirements..... | 5 |
| | 1.4 Power requirements..... | 6 |
| Chapter 2 | Wiring for all Filling Mass Transmitters..... | 7 |
| | 2.1 I/O wiring connectors location and identification..... | 7 |
| Chapter 3 | Wiring for Filling Mass Transmitters with PROFIBUS-DP..... | 9 |
| | 3.1 Set the PROFIBUS-DP network switches..... | 9 |
| | 3.2 Connect wires for output option Q..... | 10 |
| | 3.3 Connect wires for output option U..... | 12 |
| | 3.4 Connect wires for output option V..... | 15 |
| Chapter 4 | Wiring for Filling Mass Transmitters with Modbus..... | 19 |
| | 4.1 Connect wires for output option P..... | 19 |
| | 4.2 Connect wires for output option R..... | 20 |
| | 4.3 Connect wires for output option S..... | 23 |
| Chapter 5 | Supplementary information..... | 25 |
| | 5.1 Install a replacement electronics module..... | 25 |
| Appendix A | Specifications..... | 27 |
| | A.1 Physical specifications..... | 27 |
| | A.2 Electrical connections..... | 28 |
| | A.3 Digital communications..... | 28 |
| | A.4 Host interface..... | 29 |
| | A.5 Power supply..... | 29 |
| | A.6 Environmental limits..... | 30 |
| | A.7 Environmental effects..... | 30 |
| | A.8 Hazardous area classifications..... | 30 |

1 Planning

1.1 Meter components

A meter consists of the following components:

- A transmitter
- A sensor
The following sensors are compatible with the FMT:
 - All CMFS sensors
 - F025 - F100
 - H025 - H100
 - T025 - T150
- A core processor that provides additional memory and processing functions

1.2 Accessibility for maintenance

Mount the transmitter in a location and orientation that satisfies the following conditions:

- Allows sufficient clearance to open the transmitter housing cover. Micro Motion recommends 8 in (203 mm) – 10 in (254 mm) clearance at the rear of the transmitter.
- Provides clear access for installing cabling to the transmitter.

1.3 Discrete Output wiring requirements

To implement a specific fill type and fill option, the Discrete Outputs on the transmitter must be wired to the appropriate valves or devices.

See [Table 1-1](#) for requirements for discrete output wiring.

Notes

- The information presented here applies only to transmitters with Discrete Outputs.
 - Only supported options are listed.
 - The term *Configurable DO* refers to the Configurable Discrete Input/Discrete Output when configured as a Discrete Output. If the fill type and option do not require this output for the purge valve, then the Configurable Discrete Output/Discrete Input can be used for a variety of other application purposes as needed.
 - If the internal power source is used, do not connect any terminal to ground.
-

Table 1-1: Wiring requirements for fill types and fill options

| Fill type with options | Precision DO1 | Precision DO2 | Configurable DO |
|-------------------------------|---------------------|---------------------|-----------------|
| Standard one-stage | Primary valve | N/A | N/A |
| Standard one-stage with purge | Primary valve | N/A | Purge valve |
| Standard one-stage with pump | Primary valve | Pump | As needed |
| Standard two-stage | Primary valve | Secondary valve | As needed |
| Standard two-stage with purge | Primary valve | Secondary valve | Purge valve |
| Timed | Primary valve | N/A | As needed |
| Timed with purge | Primary valve | N/A | Purge valve |
| Dual-fillhead | Valve in Fillhead 1 | Valve in Fillhead 2 | As needed |
| Timed dual-fillhead | Valve in Fillhead 1 | Valve in Fillhead 2 | As needed |

1.4 Power requirements

The transmitter is powered by one of the Eurofast (M-12) connectors. Refer to the wiring instructions for your output configuration.

The power supply requirements are:

- 24 Vdc
- 5.5 W plus I/O requirements
- 1 A maximum at the 24 VIO passthrough

NOTICE

Do not connect +24 Vdc in (-) to +24 Vdc I/O (-) external to the device. The +24V/I/O passthrough supply should remain floating. If this connection is made externally, then the +24V/I/O current limit will be unable to properly operate.

2 Wiring for all Filling Mass Transmitters

2.1 I/O wiring connectors location and identification

Use the figure below to locate and identify the three I/O wiring connectors on the transmitter. These connectors are referred to by their letter names, “A”, “B”, and “C”.

Note

The pin numbers are not labeled on the transmitter or connectors. Compare the pin positions in the figure with the positions on the transmitter and connectors to determine the proper pin numbering.

Figure 2-1: I/O wiring connectors

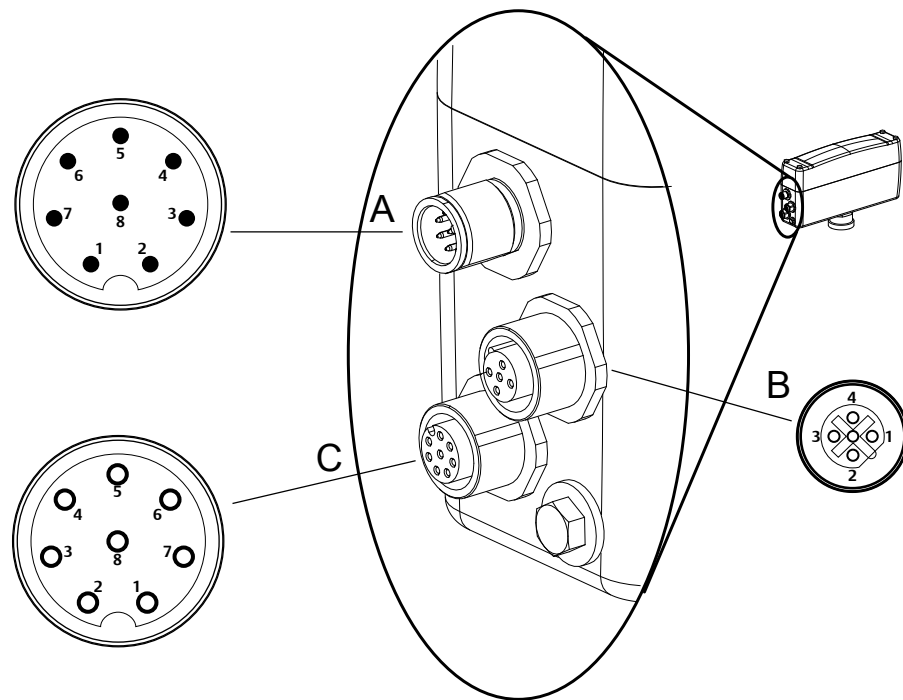

- A. 8-pin male power and Modbus® connector
- B. 5-pin female PROFIBUS® connector
- C. 8-pin female discrete I/O connector or Frequency Output and I/O power (depending upon configuration option)

3 Wiring for Filling Mass Transmitters with PROFIBUS-DP

3.1 Set the PROFIBUS-DP network switches

Before connecting the transmitter to the PROFIBUS network, you must set the device parameters using the internal PROFIBUS network address and network termination switches.

The network address and network termination switches are located inside the transmitter housing. See [Figure 3-1](#).

Figure 3-1: PROFIBUS network switches

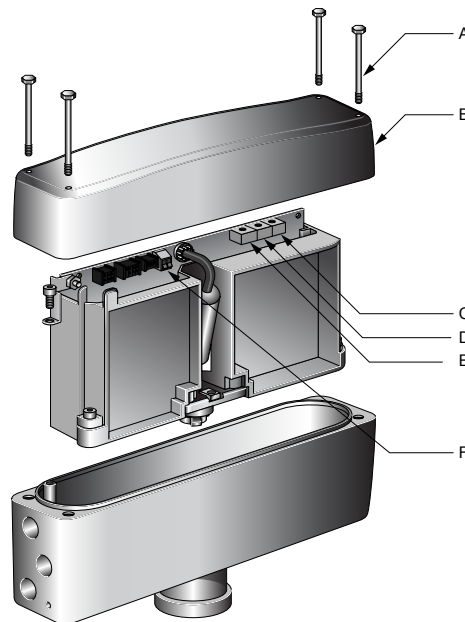

- A. 4 x 5/16" bolts
- B. Housing cover
- C. Network address switch – ones digit
- D. Network address switch – tens digit
- E. Network address switch – hundreds digit
- F. Network termination DIP switches

Procedure

1. Loosen the four 5/16" bolts securing the housing cover.
2. Lift the housing cover straight up.

3. Set the PROFIBUS network address switches as appropriate for your network.
The allowable address range for PROFIBUS-DP devices is 000 to 126. The default address is 126.
4. Set the two network termination DIP switches. Both switches must be set the same.

| Option | Description |
|---------|--|
| ON/ON | Use this option when there is a termination resistor on the local network segment. |
| OFF/OFF | Use this option when there is not a termination resistor on the local network segment. |

5. Lower the housing cover onto the base of the transmitter.
6. Tighten the four 5/16" bolts.

3.2 Connect wires for output option Q

The FMT transmitter with output option Q has a combined 24 Vdc/mA connector, a Frequency Output connector, and a PROFIBUS-DP connector.

Prerequisites

Before connecting the PROFIBUS-DP plug, you must set the internal PROFIBUS network switches.

Procedure

Insert an appropriate cable into each of the connectors shown in [Figure 3-2](#).

Figure 3-2: Option Q connectors

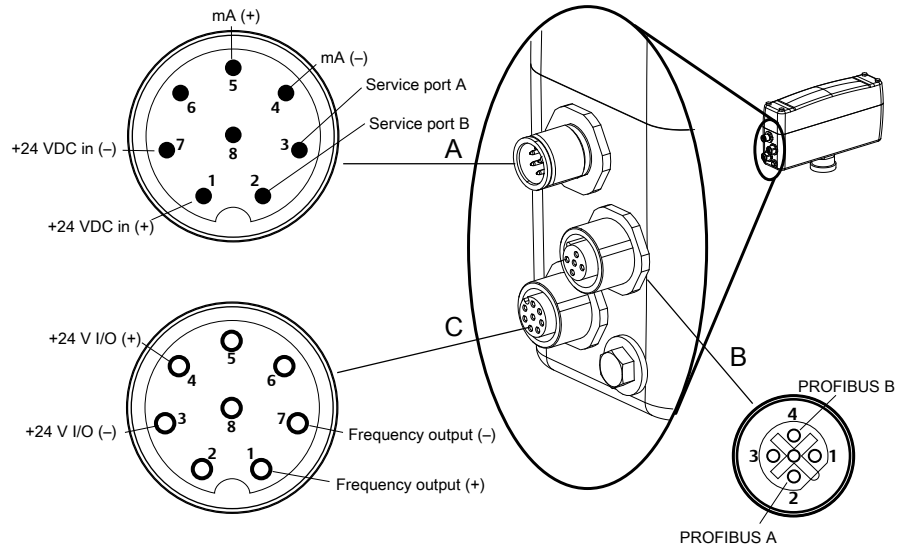

- A. 8-pin male power and Modbus connector
- B. 5-pin female PROFIBUS connector
- C. 8-pin female Frequency Output and I/O power connector

Table 3-1: Option Q - Power and Modbus connector

| Pin identification | Wire color | Outputs |
|--------------------|------------|--------------------------------------|
| Pin 1 | White | +24 Vdc in (+) |
| Pin 2 | Brown | RS-485B/Universal Service Port (USP) |
| Pin 3 | Green | RS-485A/Universal Service Port (USP) |
| Pin 4 | Yellow | mA (-) |
| Pin 5 | Gray | mA (+) |
| Pin 6 | Pink | Inactive |
| Pin 7 | Blue | +24 Vdc in (-) |
| Pin 8 | Red | Inactive |

Table 3-2: Option Q - PROFIBUS connector

| Pin identification | Wire color | Outputs |
|--------------------|------------|------------|
| Pin 1 | Inactive | Inactive |
| Pin 2 | Green | PROFIBUS A |
| Pin 3 | Inactive | Inactive |
| Pin 4 | Red | PROFIBUS B |
| Pin 5 | Inactive | Inactive |

Table 3-3: Option Q - Frequency Output and I/O power connector

| M12 pin | Wire color | Outputs |
|---------|------------|----------------------|
| Pin 1 | White | Frequency Output (+) |
| Pin 2 | Brown | Inactive |
| Pin 3 | Green | +24 V I/O (-) |
| Pin 4 | Yellow | +24 V I/O (+) |
| Pin 5 | Gray | Inactive |
| Pin 6 | Pink | Inactive |
| Pin 7 | Blue | Frequency Output (-) |
| Pin 8 | Red | Inactive |

Note

Inactive outputs should not be used for this configuration.

3.3 Connect wires for output option U

The FMT with output option U has a combined 24Vdc/mA connector, a discrete output/discrete input connector, and a PROFIBUS-DP connector. This output configuration enables direct wiring to the valve, including power output to the valve.

Prerequisites

Before connecting the PROFIBUS-DP plug, you must set the internal PROFIBUS network switches.

Procedure

Insert an appropriate cable into each of the connectors shown in [Figure 3-3](#).

Figure 3-3: Option U connectors

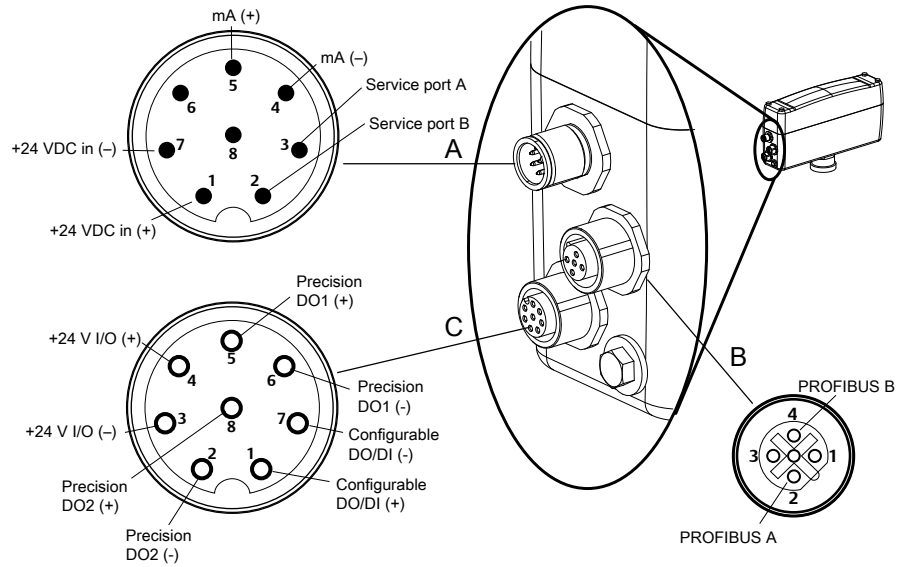

- A. 8-pin male power and Modbus connector
- B. 5-pin female PROFIBUS connector
- C. 8-pin female discrete I/O connector

Table 3-4: Option U - Power and Modbus connector

| Pin identification | Wire color | Outputs |
|--------------------|------------|--------------------------------------|
| Pin 1 | White | +24 Vdc in (+) |
| Pin 2 | Brown | RS-485B/Universal Service Port (USP) |
| Pin 3 | Green | RS-485A/Universal Service Port (USP) |
| Pin 4 | Yellow | mA (-) |
| Pin 5 | Gray | mA (+) |
| Pin 6 | Pink | Inactive |
| Pin 7 | Blue | +24 Vdc in (-) |
| Pin 8 | Red | Inactive |

Table 3-5: Option U - PROFIBUS connector

| Pin identification | Wire color | Outputs |
|--------------------|------------|------------|
| Pin 1 | Inactive | Inactive |
| Pin 2 | Green | PROFIBUS A |
| Pin 3 | Inactive | Inactive |
| Pin 4 | Red | PROFIBUS B |
| Pin 5 | Inactive | Inactive |

Table 3-6: Option U - Discrete I/O connector

| M12 pin | Wire color | Outputs |
|---------|------------|------------------------|
| Pin 1 | White | Configurable DO/DI (+) |
| Pin 2 | Brown | Precision DO2 (-) |
| Pin 3 | Green | +24 Vdc I/O (-) |
| Pin 4 | Yellow | +24 Vdc I/O (+) |
| Pin 5 | Gray | Precision DO1 (+) |
| Pin 6 | Pink | Precision DO1 (-) |
| Pin 7 | Blue | Configurable DO/DI (-) |
| Pin 8 | Red | Precision DO2 (+) |

Isolated output wiring

Figure 3-4 shows an example wiring arrangement for a primary fill valve.

Figure 3-4: Example isolated output wiring

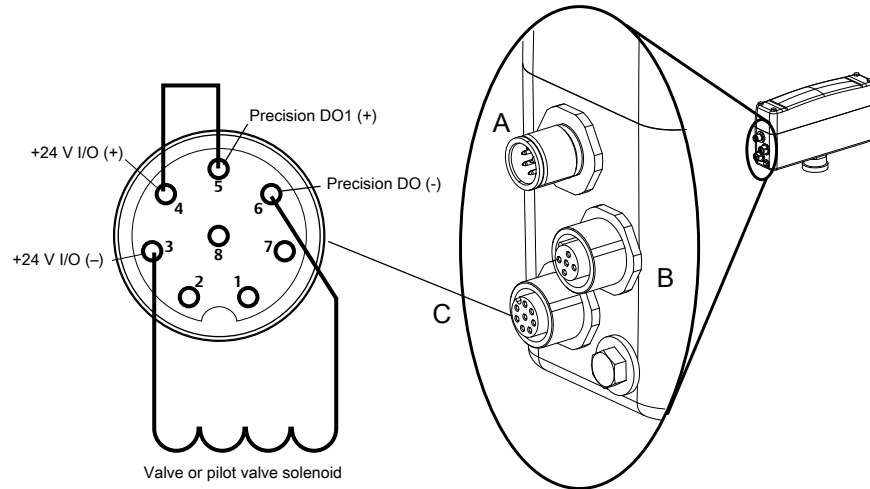

- A. 8-pin male power and Modbus connector
- B. 5-pin female PROFIBUS connector
- C. 8-pin female discrete I/O connector

3.4 Connect wires for output option V

The FMT with output option V has a combined 24V/mA connector, a Discrete Output/Discrete Input connector, and a PROFIBUS-DP connector. This output configuration enables direct wiring to the valve, including power output to the valve.

Prerequisites

Before connecting the PROFIBUS-DP plug, you must set the internal PROFIBUS network switches.

Procedure

Insert an appropriate cable into each of the connectors shown in [Figure 3-5](#).

Figure 3-5: Option V connectors

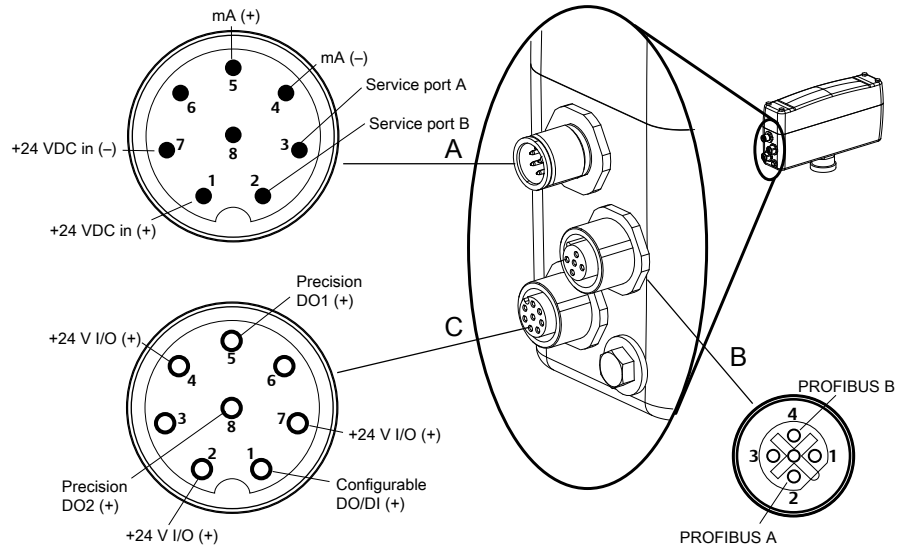

- A. 8-pin male power and Modbus connector
- B. 5-pin female PROFIBUS connector
- C. 8-pin female discrete I/O connector

Table 3-7: Option V - Power and Modbus connector

| Pin identification | Wire color | Outputs |
|--------------------|------------|--------------------------------------|
| Pin 1 | White | +24 VDC in (+) |
| Pin 2 | Brown | RS-485B/Universal Service Port (USP) |
| Pin 3 | Green | RS-485A/Universal Service Port (USP) |
| Pin 4 | Yellow | mA (-) |
| Pin 5 | Gray | mA (+) |
| Pin 6 | Pink | Inactive |
| Pin 7 | Blue | +24 VDC in (-) |
| Pin 8 | Red | Inactive |

Table 3-8: Option V - PROFIBUS connector

| Pin identification | Wire color | Outputs |
|--------------------|------------|------------|
| Pin 1 | Inactive | Inactive |
| Pin 2 | Green | PROFIBUS A |
| Pin 3 | Inactive | Inactive |
| Pin 4 | Red | PROFIBUS B |
| Pin 5 | Inactive | Inactive |

Table 3-9: Option V - Discrete I/O connector

| M12 pin | Wire color | Outputs |
|---------|------------|------------------------|
| Pin 1 | White | Configurable DO/DI (+) |
| Pin 2 | Brown | +24 V I/O (+) |
| Pin 3 | Green | Inactive |
| Pin 4 | Yellow | +24 V I/O (+) |
| Pin 5 | Gray | Precision DO1 (+) |
| Pin 6 | Pink | Inactive |
| Pin 7 | Blue | +24 V I/O (+) |
| Pin 8 | Red | Precision DO2 (+) |

Note

Valves are connected between the +24V I/O and the DO. If the valve is polarity sensitive, then Valve + goes to 24V I/O (+).

4 Wiring for Filling Mass Transmitters with Modbus

4.1 Connect wires for output option P

The FMT transmitter with output option P has a combined 24V/RS-485/mA connector and a Frequency Output connector.

Procedure

Note

The Frequency Output is passive.

Insert an appropriate cable into each of the connectors shown in [Figure 4-1](#).

Figure 4-1: Option P connectors

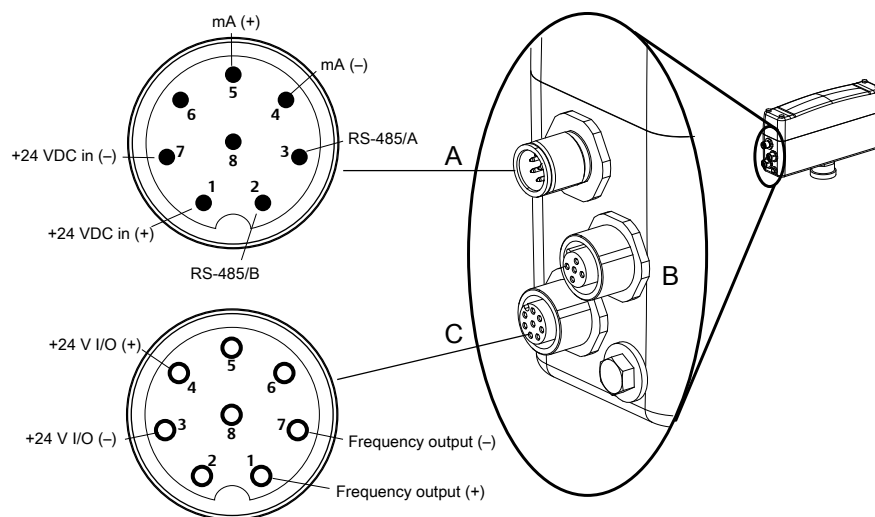

- A. 8-pin male power and Modbus connector
- B. Not used with output option P
- C. 8-pin female Frequency Output and I/O power connector

Table 4-1: Option P - Power and Modbus connector

| Pin identification | Wire color | Outputs |
|--------------------|------------|--------------------------------------|
| Pin 1 | White | +24 Vdc in (+) |
| Pin 2 | Brown | RS-485B/Universal Service Port (USP) |
| Pin 3 | Green | RS-485A/Universal Service Port (USP) |
| Pin 4 | Yellow | mA (-) |
| Pin 5 | Gray | mA (+) |
| Pin 6 | Pink | Inactive |
| Pin 7 | Blue | +24 Vdc in (-) |
| Pin 8 | Red | Inactive |

Note

Connector B is inactive with Option P.

Table 4-2: Option P - Frequency Output and I/O power connector

| M12 pin | Wire color | Outputs |
|---------|------------|----------------------|
| Pin 1 | White | Frequency Output (+) |
| Pin 2 | Brown | Inactive |
| Pin 3 | Green | +24 V I/O (-) |
| Pin 4 | Yellow | +24 V I/O (+) |
| Pin 5 | Gray | Inactive |
| Pin 6 | Pink | Inactive |
| Pin 7 | Blue | Frequency Output (-) |
| Pin 8 | Red | Inactive |

Note

Connector C, pins 2, 5, 6, and 8 should not be used with Option P.

4.2 Connect wires for output option R

The FMT transmitter with output option R has a combined 24V/RS-485/mA Output connector and a high-precision Discrete Output connector.

Procedure

Insert an appropriate cable into each of the connectors shown in [Figure 4-2](#).

Figure 4-2: Option R connectors

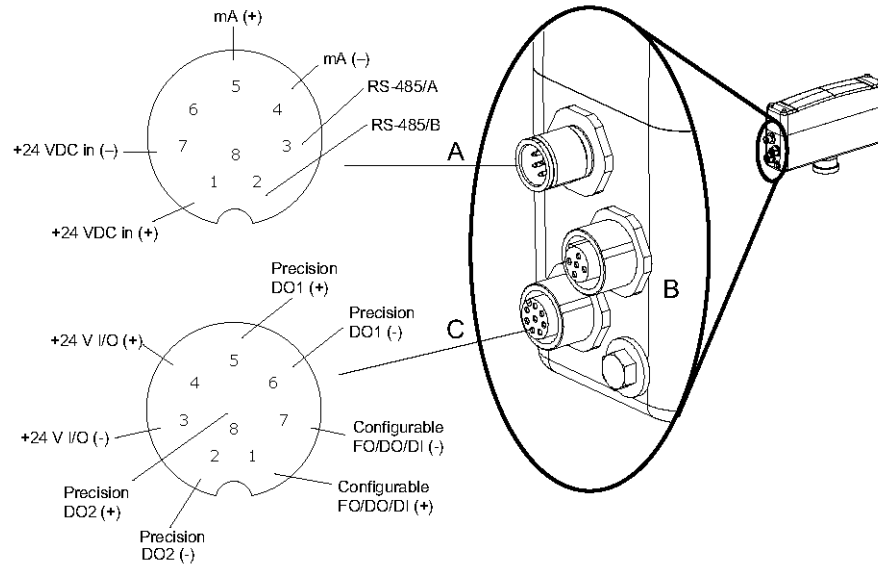

- A. 8-pin male power and Modbus connector
- B. Not used with output option R
- C. 8-pin female discrete I/O connector

Table 4-3: Option R - Power and Modbus connector

| Pin identification | Wire color | Outputs |
|--------------------|------------|--------------------------------------|
| Pin 1 | White | +24 Vdc in (+) |
| Pin 2 | Brown | RS-485B/Universal Service Port (USP) |
| Pin 3 | Green | RS-485A/Universal Service Port (USP) |
| Pin 4 | Yellow | mA (-) |
| Pin 5 | Gray | mA (+) |
| Pin 6 | Pink | Inactive |
| Pin 7 | Blue | +24 Vdc in (-) |
| Pin 8 | Red | Inactive |

Note

Connector B is inactive with output option R.

Table 4-4: Option R - Discrete I/O connector

| M12 pin | Wire color | Outputs |
|---------|------------|---------------------------|
| Pin 1 | White | Configurable FO/DO/DI (+) |
| Pin 2 | Brown | Precision DO2 (-) |
| Pin 3 | Green | +24 V I/O (-) |

Table 4-4: Option R - Discrete I/O connector (continued)

| M12 pin | Wire color | Outputs |
|---------|------------|---------------------------|
| Pin 4 | Yellow | +24 V I/O (+) |
| Pin 5 | Gray | Precision DO1 (+) |
| Pin 6 | Pink | Precision DO1 (+) |
| Pin 7 | Blue | Configurable FO/DO/DI (-) |
| Pin 8 | Red | Precision DO2 (+) |

Isolated output wiring

Figure 4-3 shows an example wiring arrangement for a primary fill valve.

Figure 4-3: Example isolated output wiring

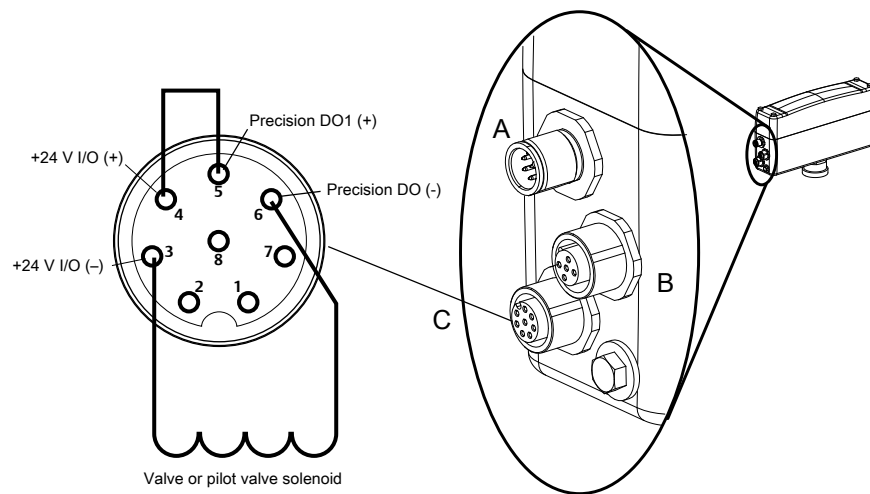

- A. 8-pin male power and Modbus connector
- B. 5-pin female PROFIBUS connector
- C. 8-pin female discrete I/O connector

4.3 Connect wires for output option S

The FMT transmitter with output option S has a combined 24V/RS-485/mA connector and a high-precision Discrete Output connector. This output configuration enables direct wiring to the valve, including power output to the valve.

Procedure

Insert an appropriate cable into each of the connectors shown in [Figure 4-4](#).

Figure 4-4: Option S connectors

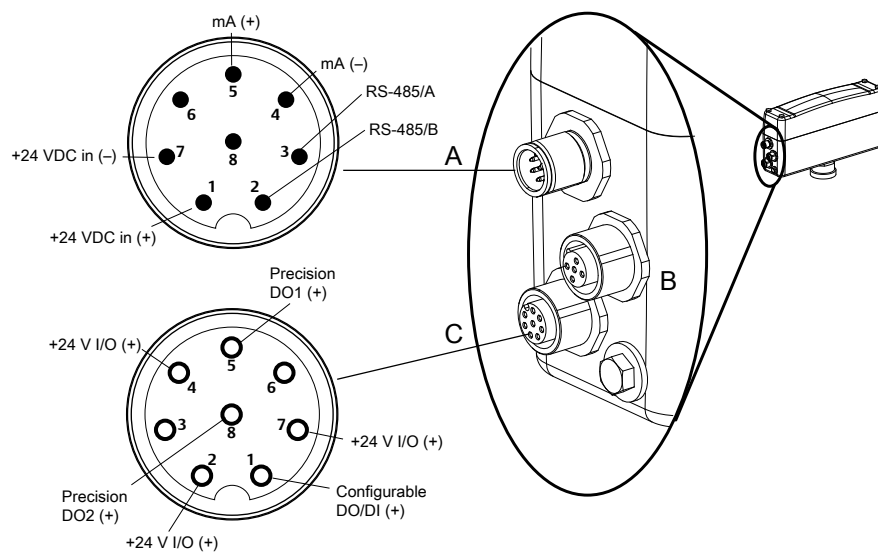

- A. 8-pin male power and Modbus connector
- B. Not used with output option S
- C. 8-pin female discrete I/O connector

Table 4-5: Option S - Power and Modbus connector

| Pin identification | Wire color | Outputs |
|--------------------|------------|--------------------------------------|
| Pin 1 | White | +24 Vdc in (+) |
| Pin 2 | Brown | RS-485B/Universal Service Port (USP) |
| Pin 3 | Green | RS-485A/Universal Service Port (USP) |
| Pin 4 | Yellow | mA (-) |
| Pin 5 | Gray | mA (+) |
| Pin 6 | Pink | Inactive |

Table 4-5: Option S - Power and Modbus connector (continued)

| Pin identification | Wire color | Outputs |
|--------------------|------------|----------------|
| Pin 7 | Blue | +24 Vdc in (-) |
| Pin 8 | Red | Inactive |

Note

Connector B is inactive with output option S

Table 4-6: Option S - Discrete I/O connector

| M12 pin | Wire color | Outputs |
|---------|------------|------------------------|
| Pin 1 | White | Configurable DO/DI (+) |
| Pin 2 | Brown | +24 V I/O (+) |
| Pin 3 | Green | Inactive |
| Pin 4 | Yellow | +24 V I/O (+) |
| Pin 5 | Gray | Precision DO1 (+) |
| Pin 6 | Pink | Inactive |
| Pin 7 | Blue | +24 V I/O (+) |
| Pin 8 | Red | Precision DO2 (+) |

Note

Valves are connected between the +24V I/O and the DO. If the valve is polarity sensitive, then Valve + goes to 24V I/O (+).

5 Supplementary information

5.1 Install a replacement electronics module

The electronics module can be removed and replaced easily.

See [Figure 5-1](#) for an illustration of the transmitter components.

Figure 5-1: Transmitter components

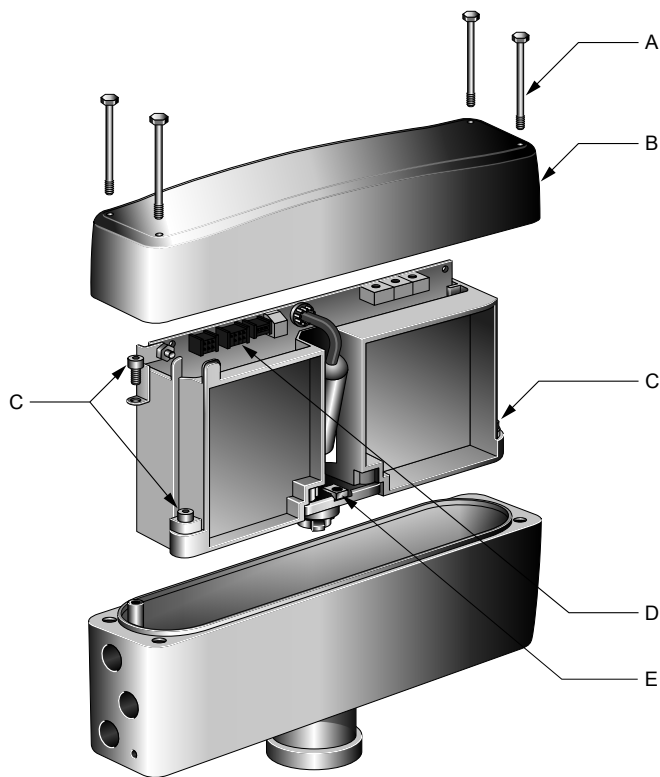

- A. 4 x 5/16" bolts
- B. Housing cover
- C. 3 x screws holding the module in place
- D. Circuit board harness connectors
- E. Alignment notch

Procedure

1. Loosen the four 5/16" bolts securing the housing cover.
2. Lift the housing cover straight up.
3. Disconnect the circuit board harness connectors.
4. Remove the three screws holding the electronics module in place.

5. Lift the electronics module out of the transmitter housing.
6. Slide the new module into the transmitter housing.

Tip

Use the alignment notch to help align the connector on the bottom of the electronics module with the 9-pin connector inside the transmitter housing.

7. Secure the new module with the three screws removed previously.
8. Reconnect the circuit board harness connectors.
9. Lower the housing cover onto the base of the transmitter.
10. Tighten the four 5/16" bolts.

A Specifications

A.1 Physical specifications

Table A-1: Coriolis Meter Item

| Item | | Description |
|----------------------|---------------------|---|
| Housing and mounting | Transmitter | 316L stainless steel |
| | | Transmitter is integrally mounted to sensor at factory. All electronics are encapsulated. <ul style="list-style-type: none"> When mounted on a CMFS sensor, the transmitter is welded to the sensor case. When mounted to other sensor models, the transmitter is clamped to the sensor case. |
| | | Exterior surfaces are optionally polished to Ra 64. |
| | NEMA 4X (IP66/IP67) | |
| | Sensor | Refer to sensor specifications for sensor case materials. |
| Weight | Transmitter | 7.1 lb (3.22 kg) |
| | Sensor | Refer to sensor specifications for sensor weight. |
| Dimensions | Transmitter | 2 in (51 mm) x 8.95 in (227.3 mm) x 5.2 in (132 mm) See Figure A-1 . |
| | Sensor | Refer to sensor specifications for sensor dimensions. |
| Status LED | | One or two status indicators on internal transmitter module (for commissioning, not visible in normal use) <ul style="list-style-type: none"> LED1: Indicates transmitter status LED2: Indicates PROFIBUS-DP connection status⁽¹⁾ |

(1) Available only with electronic output options Q, U, or V.

Figure A-1: Transmitter dimensions

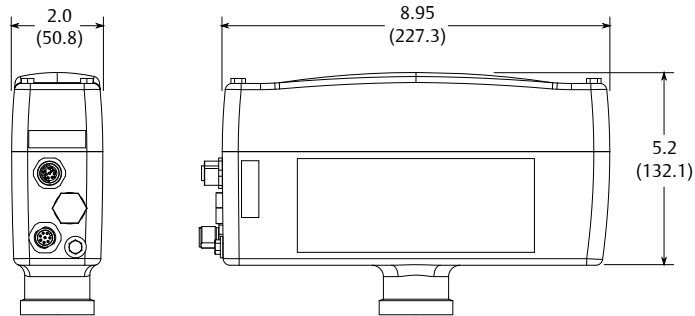

A.2 Electrical connections

Table A-2: Electrical connections

| Item | Output option | Description |
|------------------------|------------------|--|
| Connection type | | Phoenix Contact M-12 circular connectors |
| Power connection | P, Q, R, S, U, V | Power and mA on same connector |
| | T | mA on separate connector |
| Digital communications | P, R, S, T | Modbus |
| | Q, U, V | PROFIBUS-DP |
| Isolation | P,Q,R, U | Isolated I/O |
| | S,T, V | High-side common (not isolated) |

A.3 Digital communications

Table A-3: Digital communications

| Protocol | Description | |
|------------------------------|---|---|
| Service port | Standard Micro Motion service port protocol: Modbus RTU 38,400 baud rate, one stop bit, no parity | There is only one physical port for both Modbus and the service port. |
| Modbus/RS-485 ⁽¹⁾ | Auto-detects and responds to: <ul style="list-style-type: none"> • Modbus RTU protocol • All baud rates between 1200 and 38,400 • One or two stop bits • Any parity | |
| PROFIBUS-DP ⁽²⁾ | Digital 2-way communications protocol | |

Table A-3: Digital communications (continued)

| Protocol | Description |
|----------|--|
| | Automatically recognizes network baud rate |

- (1) Available only with output option P, R, S, or T.
 (2) Available only with output option Q, U, or V.

A.4 Host interface

Table A-4: Host interface

| Output option | Interface |
|---------------|---|
| Q, U, V | <p>DPV-1 host with acyclic communication is required for basic functionality</p> <p>ProLink III software, or a Siemens SIMATIC PDM are required for complete device configuration</p> <p>Supplied with transmitter:</p> <ul style="list-style-type: none"> • GSD file conforming to the PROFIBUS-DP specification <ul style="list-style-type: none"> – Provides PROFIBUS Class 1 Master functions – Enables control of all input and output process data • DD file conforming to PROFIBUS EDDL specification <ul style="list-style-type: none"> – Provides PROFIBUS Class 2 Master functions – Enables device configuration |

A.5 Power supply

Table A-5: Power supply

| Item | | Description |
|--------------------|---------------------|---|
| Power requirements | Input supply | 24 VDC |
| | System requirements | 5.5 W (device) + I/O requirements (1 A max at 24 VIO passthrough) |
| Fuse | Device fuse | 800 mA |
| | 24 VIO fuse | 1.6 A |
| Safety | | Reverse-polarity and short-circuit protection Complies with low voltage directive 2006/95/EC per IEC 61010-1 Installation (overvoltage) Category II, Pollution Degree 2 |

A.6 Environmental limits

Table A-6: Environmental limits

| Type | Limits |
|----------------------------|--|
| Ambient temperature limits | -32 °F (-36 °C) to 140 °F (60 °C) |
| Humidity limits | 5 to 95% relative humidity, non-condensing at 140 °F (60 °C) |
| Vibration limits | Meets IEC68.2.6, endurance sweep, 5 to 2000 Hz, 50 sweep cycles at 1.0 g |



A.7 Environmental effects

Table A-7: Environmental effects

| Type | Effect |
|----------------------------|--|
| EMI effects | Complies with EMC directive 2008/104/EC per EN 61326-2-3 |
| | Complies with NAMUR NE21 Version: 22.08.2007 |
| Ambient temperature effect | On mA Output: $\pm 0.005\%$ of span per °C |

A.8 Hazardous area classifications

Table A-8: Hazardous area classifications

| Agency | Approval |
|----------|---|
| CSA C-US |  Class I, Div. 2, Groups A,B,C,D Class II, Div. 2, Groups F, G |
| ATEX |  II 3G Ex nA IIC T5 Gc II 3D Ex tc IIIC T70° C Dc IP 66/67 |
| IECEX | Ex nA IIC T5 Gc IP 66/67 |



MMI-20017127
Rev. AI
2022

For more information: www.emerson.com

©2022 Micro Motion, Inc. All rights reserved.

The Emerson logo is a trademark and service mark of Emerson Electric Co. Micro Motion, ELITE, ProLink, MVD and MVD Direct Connect marks are marks of one of the Emerson Automation Solutions family of companies. All other marks are property of their respective owners.

ROSEMOUNT™

