

Model CH-16D

Instruction Manual
P/N 51747750
May 1992

Larson-Lane Condensate Analyzer

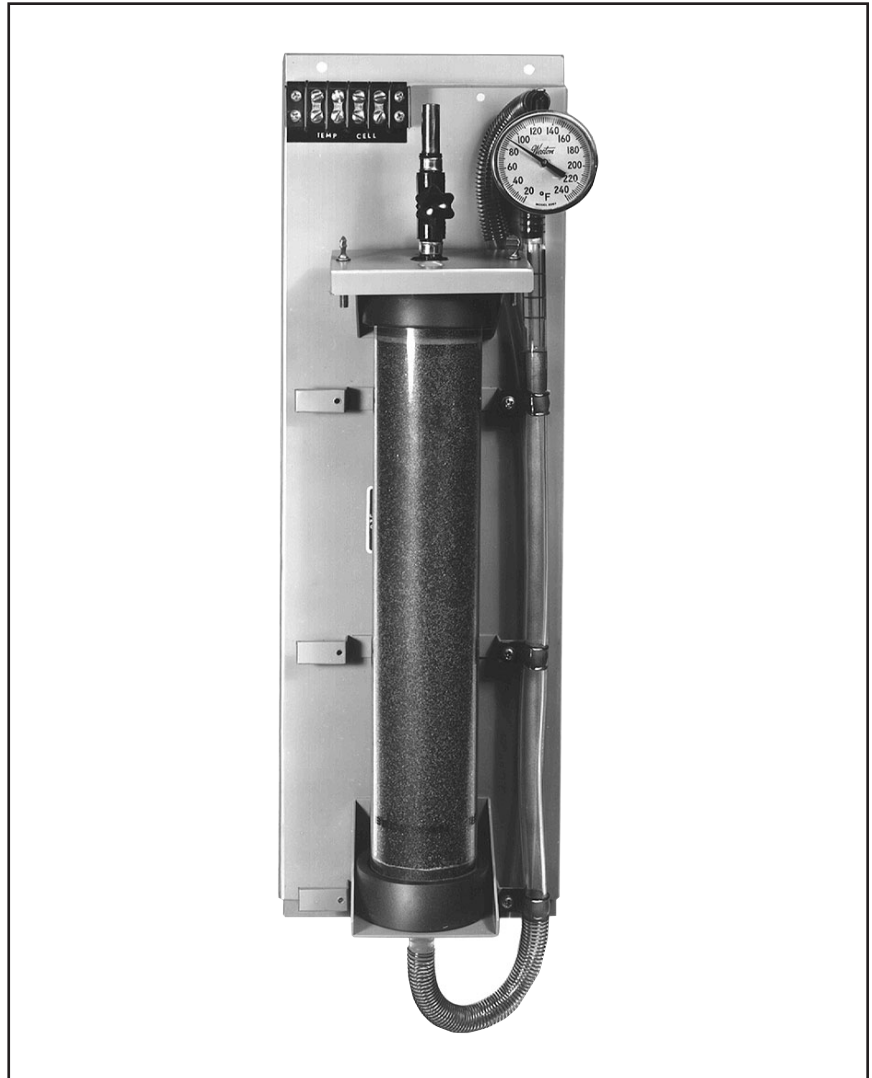

ROSEMOUNT[®] ANALYTICAL
FISHER-ROSEMOUNT[™] Managing The Process Better.[™]

TABLE OF CONTENTS

<u>SECTION</u>	<u>TITLE</u>	<u>PAGE</u>
1.0	Description and Purpose	1
1.1	General	1
1.2	Specifications	1
2.0	Operation	2
2.1	Unpacking and Inspection of Equipment	2
2.2	Installation	2
3.0	Maintenance	3
3.1	Cartridge Replacement	3
3.2	Cell Maintenance	4
4.0	Spare Parts List	5

ILLUSTRATIONS

<u>SECTION</u>	<u>TITLE</u>	<u>PAGE</u>
1	Installation Dwg. D045-747718	6
2	Outline Dimensional Dwg. D-045-747200	7
3	CH-16 Assembly Dwg. D-045-747199	8

1.0 DESCRIPTION AND PURPOSE

1.1 General

The Model CH-16D Larson-Lane Condensate Analyzer combines sample treatment by ion exchange resin and electrolytic conductivity measurements to provide an indication of dissolved solids content. The sample passes through a hydrogen form cation exchanger which removes ammonia and amines and at the same time converts dissolved salts to their corresponding acids. In this way ammonium hydroxide is converted to water and sodium chloride to hydrochloric acid. Measurement of the electrolytic conductivity of the sample after the ion exchanger provides indication of dissolved solids content without interference from the ammonia or amines which have been removed. Conversion to the acid increases the conductivity several times and also increases the sensitivity of the measurement to changes in dissolved solids content. Generally, under normal operating conditions, the measurement of conductivity after the ion exchanger can be related directly to dissolved solids content by correlation with chemical analyses. However, under upset conditions or in the presence of condenser leaks which may introduce carbon dioxide or other materials these established relationships may not hold. Comparison of the conductivity of the sample before and after the ion exchanger can be combined with analyses to provide an indication of ammonia concentration and also to indicate when the ion exchange cartridge needs to be replaced.

1.2 Specifications

Sample: 25 lb/hr, 11.3 Kg/hr, normal

Inlet Temperature: 122°F, 50°C, maximum

Inlet Reserve: 5 psig, 34.5 Pa maximum

Inlet Fitting: 3/8", 9.5 mm, O.D. stainless steel tube

Resin Life: 3-6 months, depending on electrolyte concentration

2.0 OPERATION

2.1 Unpacking and Inspection of Equipment

Each Analyzer is carefully packed before shipment. If damage is evident, communicate with Rosemount Analytical Inc. Do not return the Analyzer before receiving shipping instructions.

Note

Sample cooling and pressure reduction may be necessary to meet the permissible temperature and pressure requirements of the CH-16D. See Section 1.2 of this manual.

2.2 Installation

2.2.1 Choosing a Location

The selection of a suitable location for mounting the Analyzer will insure satisfactory operation of the equipment. Best results will be obtained if the unit is located in a clean place free from excessive vibration.

2.2.2 Mounting the Analyzer

The unit is designed for front-of-board mounting, in a vertical position only.

2.2.3 Piping Connections

The CH-16D Analyzer is shipped completely assembled except for ion exchange cartridge, conductivity cell and automatic temperature compensator (if ordered). The condensate sample line can be connected to the 3/8" O.D. stainless steel sample inlet tube by any convenient means. 3/8" I.D. Tygon tubing is recommended. The outlet line should be run down to waste by connecting a convenient length of metallic or plastic tubing. Never block the outlet line so as to create pressure in the analyzer.

2.2.4 Installation of Cell and Temperature Compensator

The CH-16D Larson-Lane Condensate Analyzer is designed for use with glass or plastic flow-through type conductivity cells and temperature compensators such as Rosemount Analytical Inc. Type CEL-D and T/C K HD or CEL-PD K . The latter has an integral compensator. Refer to the assembly drawing, Section 3.3 of this manual, note the relative positions of the cell and compensator elements.

To install either cell or temperature compensator provided, position the element as shown in the figure, cut out a section of the Tygon tubing, and push the free ends of the tubing over the inlet and outlet connections of the cell (or compensator) element. Use a few drops of water as a lubricant. Dress the leadwires as shown in drawing for connection to the terminal block. Install terminal block cover.

2.2.5 Cartridge Installation

To install the resin cartridge, proceed as follows:

1. Loosen the thumb screws at the top of the cartridge holder. Raise the upper clamp.
2. Remove the protective end caps on the cartridge and install the cartridge in the holder, making sure that one neoprene washer is in place in each socket.
3. Tighten the thumb screws to compress these sealing washers.
4. Open upper valve and adjust flow rate so that the flowmeter ball is positioned at the middle line. (This represents a flow of approximately 25 lb/hr, 11.3 Kg/hr).
5. If the system tends to siphon, loosen or remove completely the small stainless steel screw at the high point of the outlet line. Allow several hours for rinse down after initial startup.

3.0 MAINTENANCE

3.1 Cartridge Replacement

1. Close valve at top of cartridge holder. Loosen thumb screws and allow cartridge to drain. Raise upper clamp, and replace cartridge as noted in Section 2.2.5.
2. The conductivity cell can be inspected without disassembly. Under normal operating conditions, the cell should require only infrequent servicing. For cleaning and replatinization of the cell, proceed as described below.

3.2

Cell Maintenance

It is recommended that conductivity cells in service be inspected at regular intervals. Conditions of service will determine the frequency of inspection that is necessary. Any unusual behavior of the conductivity record, unattributable to known variations in the system being measured, should be taken as a possible indication that the cell requires cleaning. A gradual appearance and increase of sluggishness and lag in the recorder action is almost always identified with dirty conductivity cells.

Conductivity cells may be cleaned and replatinized by the following procedure:

1. Remove the cell from the analyzer.
2. Fill the electrode chamber of the cell with 10-15% hydrochloric acid and allow to stand for a few minutes.
3. Rinse thoroughly with running water at low velocity.
4. Fill the cell with platinizing solution* containing 3 grams of platinic chloride and 0.02 grams of lead acetate per 100 mL distilled water.
5. Connect the cell leads to a 1-1/2 volt dry cell. Reverse the polarity every few seconds. Continue plating for 30 seconds with cell constants below 0.1/cm and for 60 seconds with cells of 0.1/cm and above.
6. Rinse the cell for a few minutes with running tap water at low velocity.
7. Reinstall cells and allow to clean up for several hours on running sample.

*Prepared platinizing solution in 100 mL bottle available as Cat. No. PL-1.

**Platinizing Kit, with batteries, meter, reversing switch available as Cat. No. PK-1A.

4.0

SPARE PARTS LIST

The following items are recommended spare parts to stock.

<u>SYMBOL</u>	<u>DESCRIPTION</u>	<u>PART NO.</u>
1	Cartridge with Resin	299-747164
1A	Color Indicating Cartridge	299-747719
2	Term. Marker (4 Pos.)	691-747231
2A	Term. Marker (8 Pos.)	691-747182
3	Term. Block (4 Pos.)	1332L
3A	Term. Block (8 Pos.)	2593L
4	Term. Shield (4 Pos.)	42151D
4A	Term. Shield (8 Pos.)	864-747458
5	Thermometer Holder	338-747173
6	Thermometer	805-881090
12	Gasket, Cartridge Seal	175-747177
14	Phenolic Clamp	RI 363L
15	Flowmeter Ball	7455E
17	Flowmeter Tube	196-747178
19	Retaining Spring	8451M
21	Tubing, Tygon, 3/8 D	3191RE
22	Vacuum Relief Screw	4743S
	Instruction Manual	51-747750

ITEM NO.	DESCRIPTION	REQD	PART NUMBER
* 1	RESIN CARTRIDGE ASSY	1	299-10747164
* 1A	COLOR INDICATING CART ASSY	1	299-10747179
* 2	TERM BLOCK MARKER STRIP (4)	1	691-10747231
* 2A	TERM BLOCK MARKER STRIP (8)	1	691-10747182
* 3	TERMINAL BLOCK (4 TERM.)	1	1332L
* 3A	TERMINAL BLOCK (8 TERM.)	1	2593L
* 4	SHIELD (4 POS)	1	4215D
* 4A	SHIELD (6 POS)	1	664-10747458
* 5	THERMOMETER HOLDER	1	338-10747173
* 6	THERMOMETER	1	805-881090
* 7	ADAPTER 1/8 X 3/8	1	182-10747294
* 8	ADAPTER 1/8 X 3/8	1	182-881092
* 9	ELBOW 1/8 X 3/8	1	186-10747180
* 10	GLOBE VALVE	1	194-881091
* 11	UPPER & LOWER CAP	2	297-10747175
* 12	UPPER & LOWER GASKET	2	175-10747177
* 13	CLAMP PLATE	1	358-10747168
* 14	PHENOLIC CLAMP	3	R1363L
* 15	FLOW BALL	1	7455E
* 16	FLOW BALL GUARD (INLET)	1	337-10747179
* 17	FLOW METER	1	196-10747178
* 18	MTG BRACKET SHIELD	2	327-171192
* 19	RETAINING SPRING	2	8451M
* 20	THUMB SCREW	2	101-836447
* 21	TYGON TUBING	3FT	31918E
* 22	6-32 X .25 LG. SCREW	1	4743S
* -	INSTRUCTION MANUAL	1	013-10747750
* -	KIT CELL INSTALLATION INLET SIDE	1	060-10747739

NOTES: * ASTERISK (*) DENOTES RECOMMENDED SPARE PARTS TO STOCK.

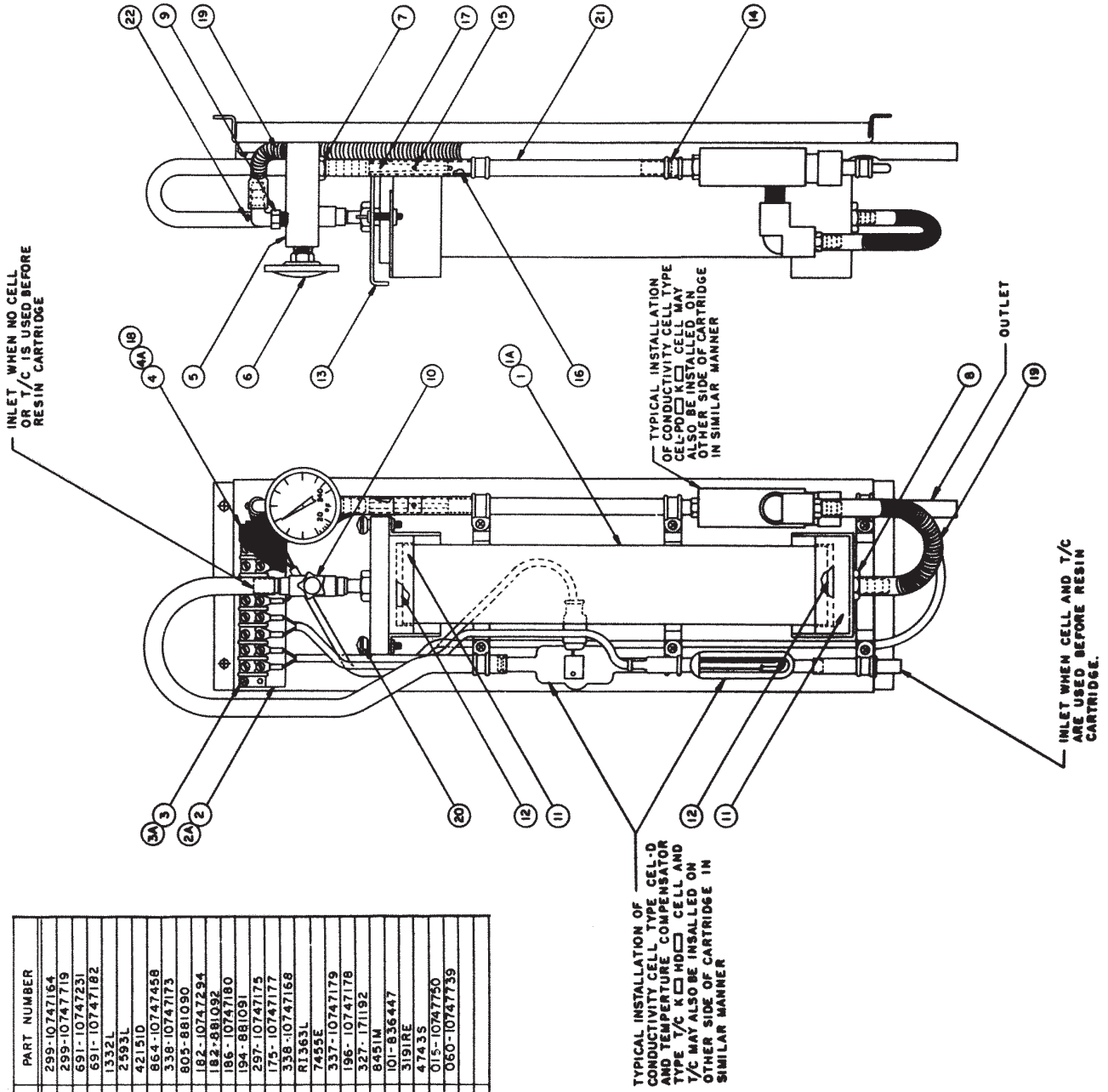

FIG. 1
INSTALLATION DWG.

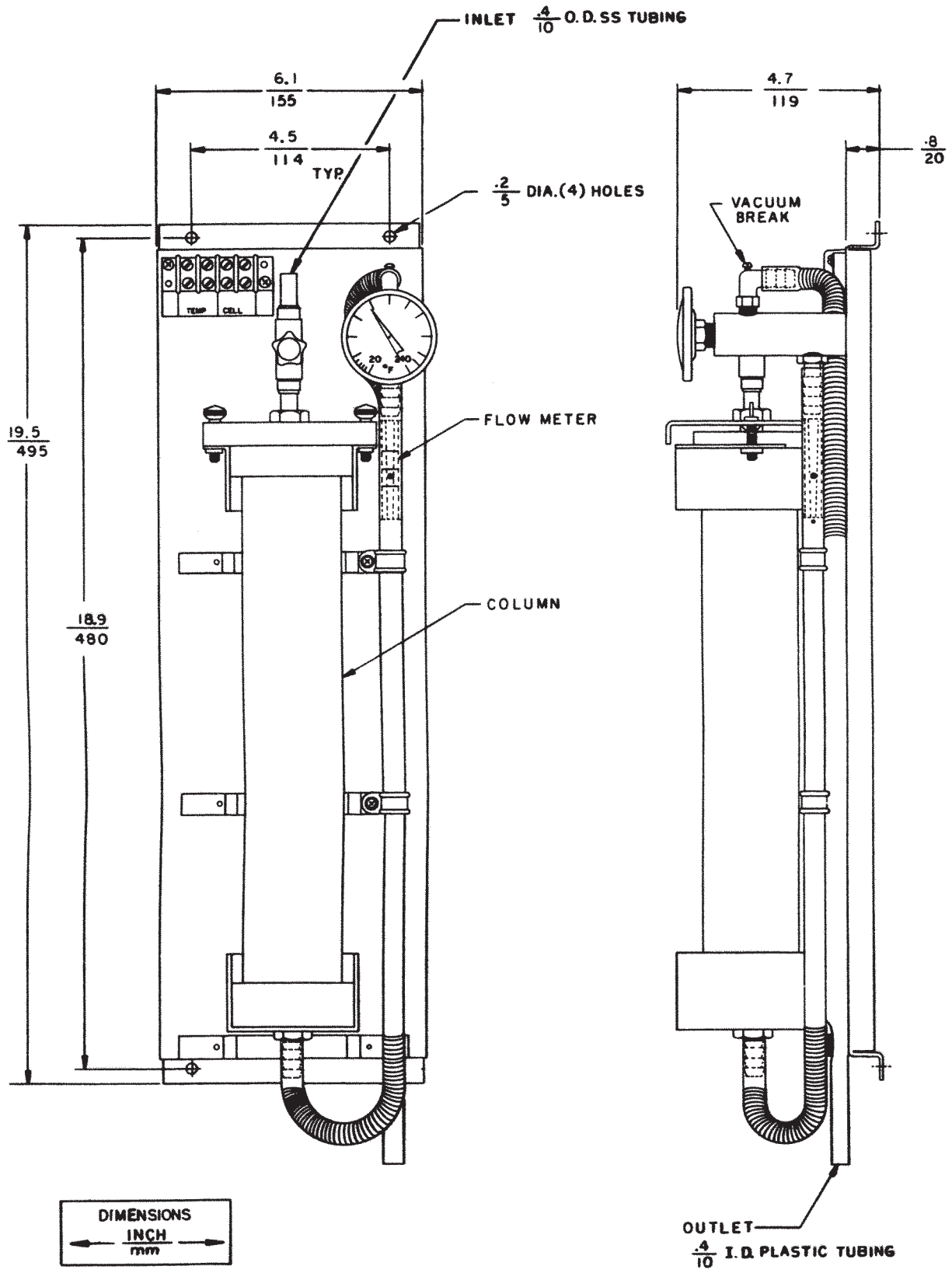
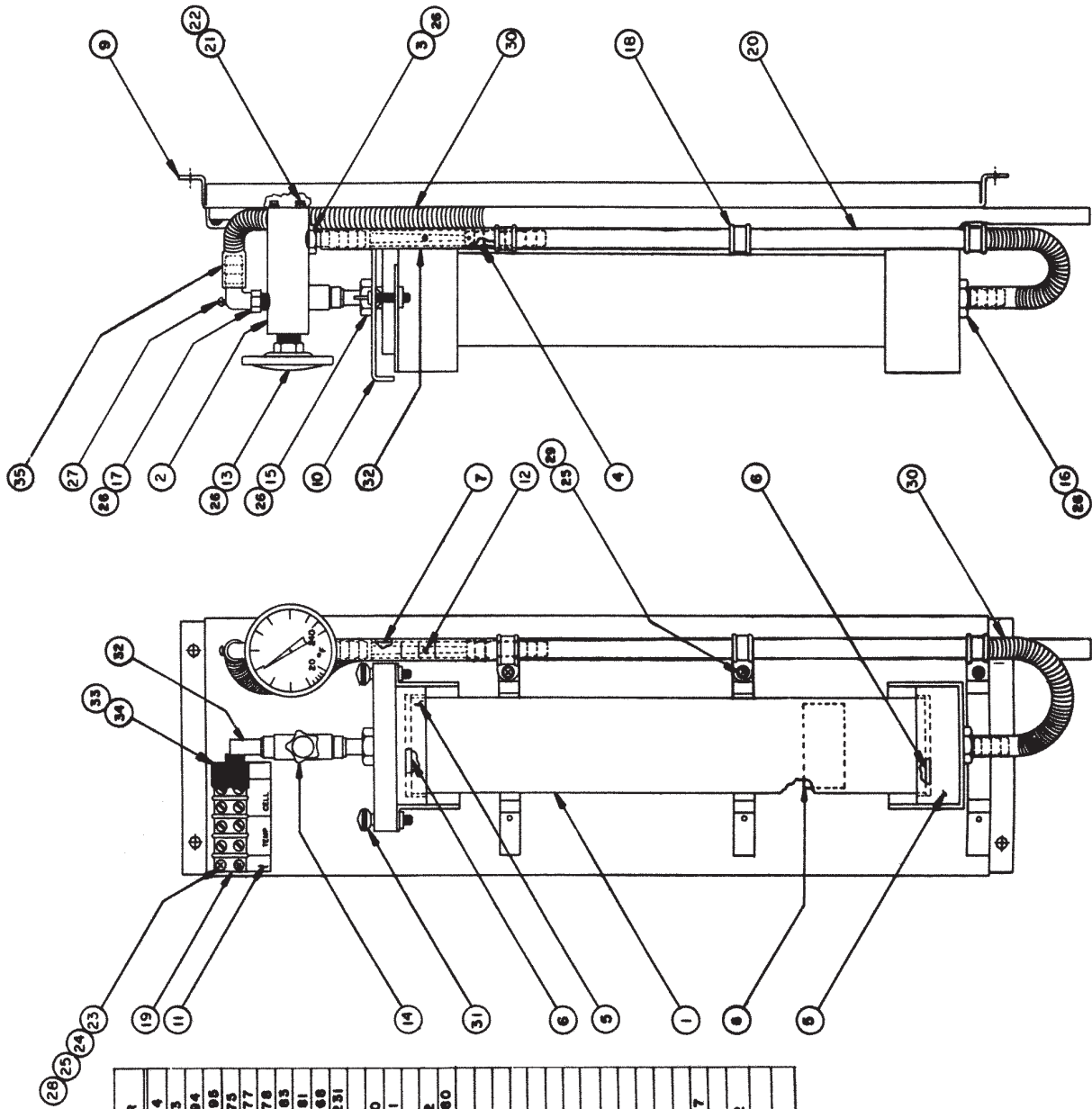

FIG. 2
OUTLINE DIMENSIONAL DWG.



ITEM NO.	DESCRIPTION	REQD	PART NUMBER
1	RESIN CARTRIDGE ASSY	1	289-10747164
2	THERMOMETER HOLDER	1	338-10747173
3	ADAPTER 1/8 X 3/8	1	182-10747284
4	FLOW BALL GUARD (INLET)	1	182-10747285
5	UPPER & LOWER CAP	2	297-10747179
6	UPPER & LOWER GASKET	2	173-10747177
7	FLOW METER	1	194-10747178
8	NAMEPLATE	1	261-10747185
9	PANEL	1	433-10747181
10	CLAMP PLATE	1	338-10747186
11	TERM. BLOCK MARKER STRIP (4)	1	691-10747231
12	FLOW BALL	1	7435E
13	THERMOMETER	1	605-881090
14	GLOBE VALVE	1	194-881091
15	ADAPTER 3/8	1	36538M
16	ADAPTER 3/8	1	182-881092
17	ELBOW 1/8 X 3/8	1	186-10747180
18	PHENOLIC CLAMP	3	R1363L
19	TERMINAL BLOCK (4 TERM.)	1	1332L
20	TYGON TUBING 3/8 I.D.	1.8 FT.	3191RE
21	9-32 X .88 LG. P.H.M.S.	2	29140S
22	8 LOCKWASHER	2	29144W
23	6-32 X .62 LG P.H.M.S.	4	31847B
24	6 LOCKWASHER	4	29143W
25	6 FLATWASHER	6	31841W
26	PIPE TAPE	.10 RL.	45-045-12
27	6-32 X .25 LG. SCREW	1	4743S
28	6-32 NUT	4	31038N
29	6-32 X .88 LG. SELF-TAP SCREW	1	4734S
30	RETAINING SPRING	2	8461M
31	SHOULDER SCREW	2	101-886447
32	TYGON TUBING	.87 FT.	3091RE
33	MTG. BRACKET	2	327-171192
34	SHIELD	1	42151D
35	TYGON TUBING	1.8 FT.	3191RE

FIG. 3
CH-16 ASSEMBLY DWG.

WARRANTY

Goods and part(s) (excluding consumables) manufactured by Seller are warranted to be free from defects in workmanship and material under normal use and service for a period of twelve (12) months from the date of shipment by Seller. Consumables, pH electrodes, membranes, liquid junctions, electrolyte, O-rings, etc. are warranted to be free from defects in workmanship and material under normal use and service for a period of ninety (90) days from date of shipment by Seller. Goods, part(s) and consumables proven by Seller to be defective in workmanship and / or material shall be replaced or repaired, free of charge, F.O.B. Seller's factory provided that the goods, parts(s), or consumables are returned to Seller's designated factory, transportation charges prepaid, within the twelve (12) month period of warranty in the case of goods and part(s), and in the case of consumables, within the ninety (90) day period of warranty. This warranty shall be in effect for replacement or repaired goods, part(s) and consumables for the remaining portion of the period of the twelve (12) month warranty in the case of goods and part(s) and the remaining portion of the ninety (90) day warranty in the case of consumables. A defect in goods, part(s) and consumables of the commercial unit shall not operate to condemn such commercial unit when such goods, parts(s) or consumables are capable of being renewed, repaired or replaced.

The Seller shall not be liable to the Buyer, or to any other person, for the loss or damage, directly or indirectly, arising from the use of the equipment or goods, from breach of any warranty or from any other cause. All other warranties, expressed or implied are hereby excluded.

IN CONSIDERATION OF THE STATED PURCHASE PRICE OF THE GOODS, SELLER GRANTS ONLY THE ABOVE STATED EXPRESS WARRANTY. NO OTHER WARRANTIES ARE GRANTED INCLUDING, BUT NOT LIMITED TO, EXPRESS AND IMPLIED WARRANTIES OF MERCHANTABILITY AND FITNESS FOR A PARTICULAR PURPOSE.

RETURN OF MATERIAL

Material returned for repair, whether in or out of warranty, should be shipped prepaid to:

**EMERSON Process Management
Rosemount Analytical Inc.
2400 Barranca Parkway
Irvine, CA 92606**

The shipping container should be marked:

Return for Repair

Model _____

The returned material should be accompanied by a letter of transmittal which should include the following information (make a copy of the "Return of Materials Request" found on the last page of the Manual and provide the following thereon):

1. Location type of service, and length of time of service of the device.
2. Description of the faulty operation of the device and the circumstances of the failure.
3. Name and telephone number of the person to contact if there are questions about the returned material.
4. Statement as to whether warranty or non-warranty service is requested.
5. Complete shipping instructions for return of the material.

Adherence to these procedures will expedite handling of the returned material and will prevent unnecessary additional charges for inspection and testing to determine the problem with the device.

If the material is returned for out-of-warranty repairs, a purchase order for repairs should be enclosed.

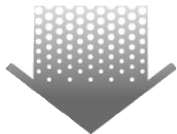

The right people, the right answers, right now.

UNILOC DIVISION
CUSTOMER SUPPORT CENTER
1-800-854-8257

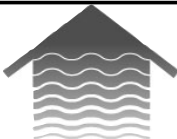

Rosemount Analytical Inc.
Uniloc Division
2400 Barranca Parkway
Irvine, CA 92606 USA
Tel: (949) 863-1181
<http://www.RAuniloc.com>



ON-LINE ORDERING NOW
AVAILABLE ON OUR WEB SITE
<http://www.RAuniloc.com>

ROSEMOUNT® ANALYTICAL

FISHER-ROSEMOUNT™