

Q-Series

Switch Adjustment and Feedback Mechanism replacement

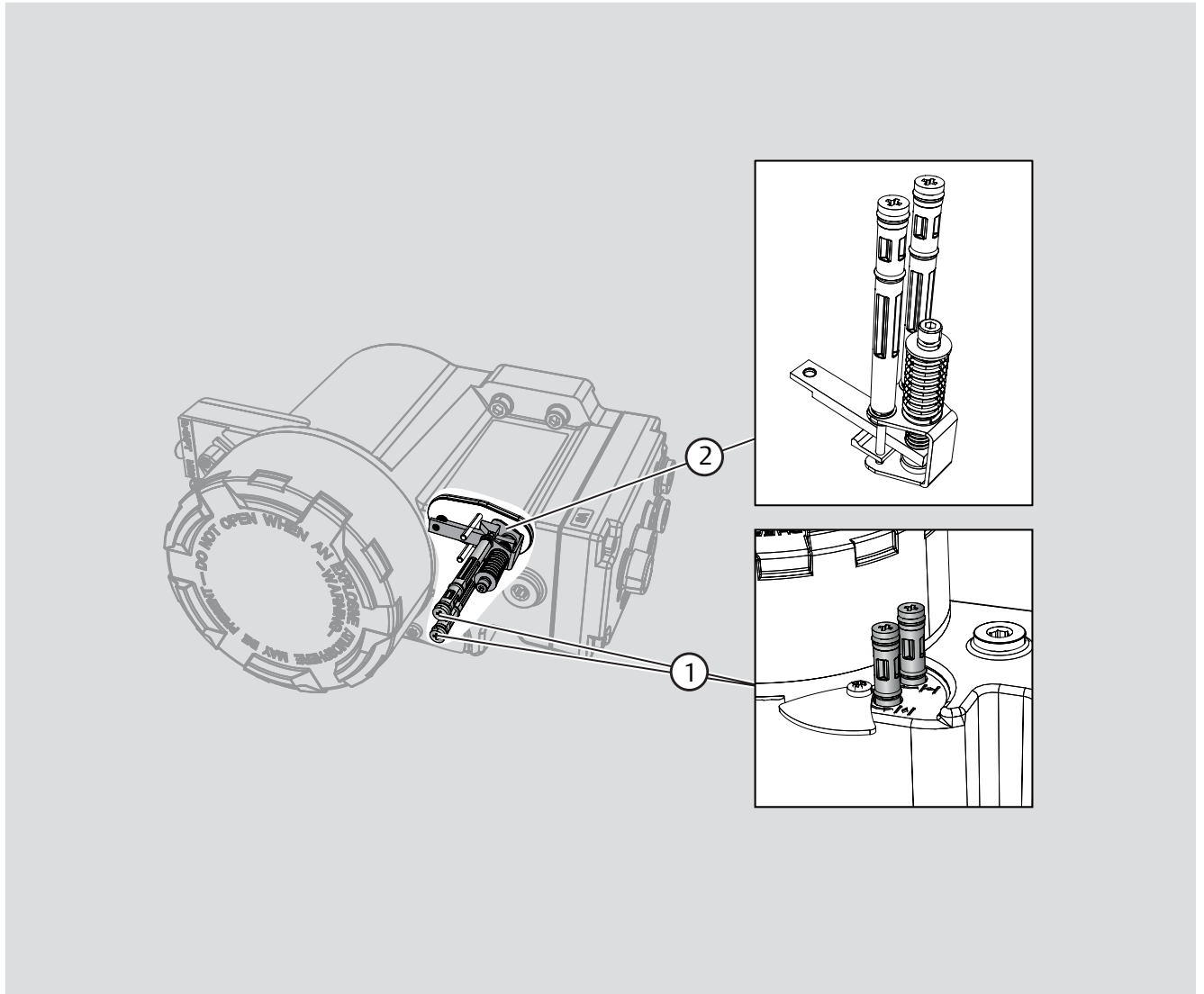

Contents

1	Before you start	4
	Scope.....	4
	General safety messages	4
	Required tools.....	5
2	Disassembly procedure.....	6
3	Reassembly procedure.....	9
4	Adjusting the switch points.....	11

1 Before you start

1.1 Scope

This repair manual is intended to give instructions to replace the switch adjustment screws and/or the feedback mechanism of the Q-Seires Control modules.

1. Repair of the switch adjustment screws may be necessary in case too much force was applied on the screw heads and the screw heads were damaged as such.
2. Repair of the feedback mechanism may be necessary in case too much force was applied on the threads of the mechanism and threads were damaged as such.

Figure 1 Scope of the manual

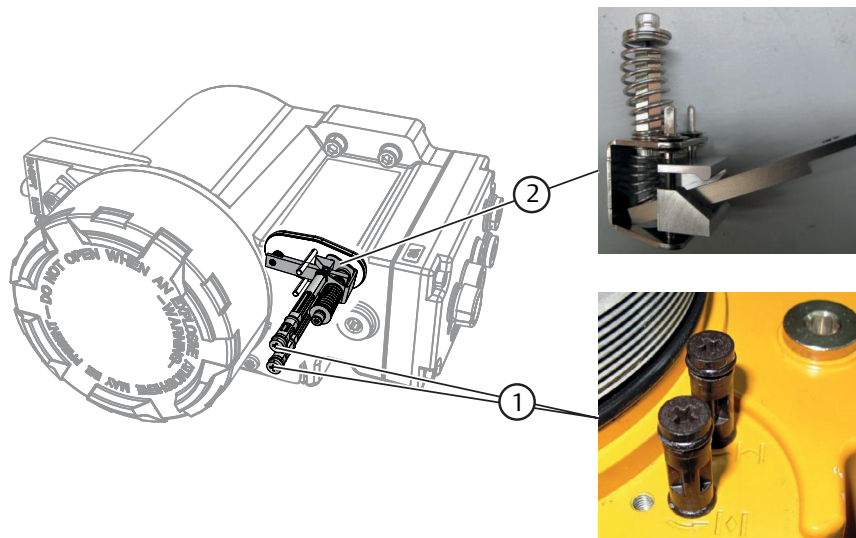

1.2 General safety messages

▲ WARNING

Avoid personal injury or property damage from sudden release of process pressure or bursting of parts. Before performing any maintenance procedures on the QC range of Control Modules:

- Always wear protective clothing, gloves, and eye wear when performing any maintenance procedures to avoid personal injury or property damage.
- Do not remove the actuator from the valve while the valve is still pressurized.
- Disconnect any operating lines providing air pressure, electric power, or a control signal to the actuator. Be sure the actuator cannot suddenly open or close the valve.
- Use bypass valves or completely shut off the process to isolate the control valve from process pressure. Relieve process pressure from both sides of the valve.
- Use lock-out procedures to be sure that the above measures stay in effect while you work on the equipment.
- Check with your process or safety engineer for any additional measures that must be taken to protect against process media.
- Vent the pneumatic actuator loading pressure and relieve any actuator spring pre-compression so the actuator is not applying force to the valve stem; this will allow for the safe removal of the stem connector.
- Do not remove or replace while circuit is live when a flammable or combustible atmosphere is present.
- Substitution of electronics cartridge, switch cartridge, pilot valve cartridge, pneumatic cartridge, enclosure and seals must be with parts from Emerson else the suitability for Division 1 or 2 will be impaired. Always use proper component replacement techniques, as presented in this manual. Improper techniques or component selection may invalidate the approvals and the product specifications, as indicated in applicable Control module Installation Guides and may also impair operations and the intended function of the device.

IMPORTANT

When replacing any of the components of the Control Module, the maintenance should be performed in an instrument shop whenever possible. Make sure that the electrical wiring and pneumatic tubing is disconnected prior to disassembling the instrument.

1.3 Required tools

In order to replace the switch adjustment screws and/or feedback mechanism below tool are required.

Figure 2 Required tools

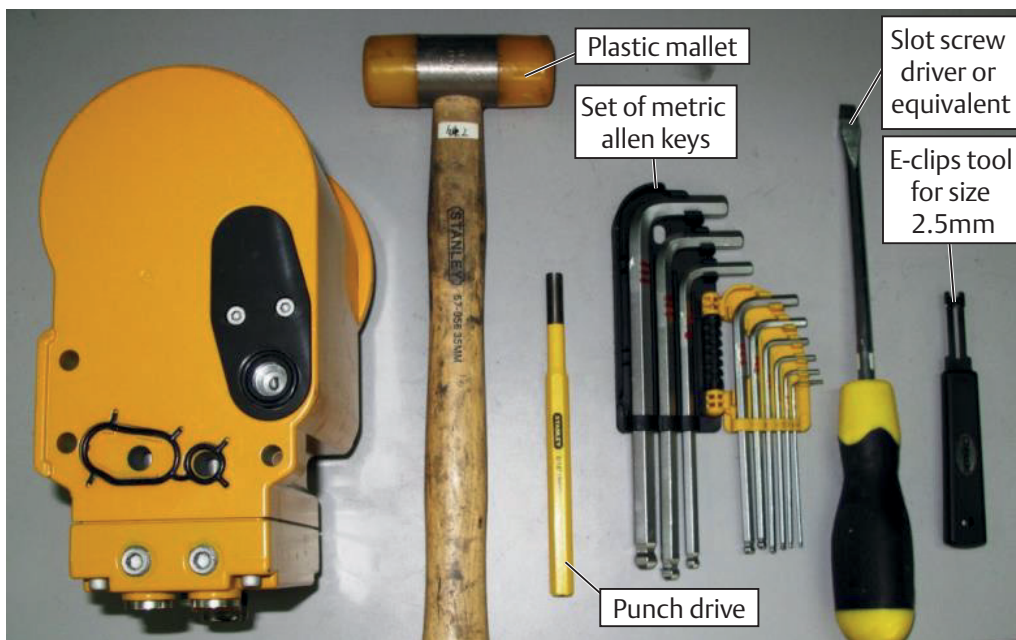

2 Disassembly procedure

IMPORTANT

In order to replace the adjustment screws, first the feedback mechanism needs to be disassembled.

1. Remove the cover screws on the back side of the control module. Check if the O-ring seals are in good shape. Replace if necessary.

Figure 3 Remove the cover screws



3 mm Allen key

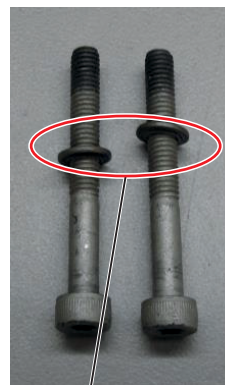

Pay attention to the two bound seal washers

2. Remove the cover and guide bushing. Check if the O-ring seals are in good shape. Replace if necessary.

Figure 4 Remove cover and guide bushing

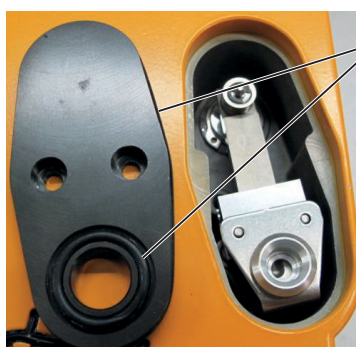

Pay attention to the two bound seal washers

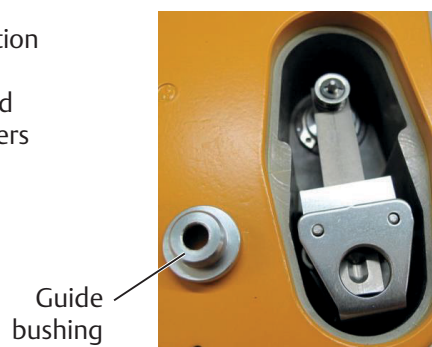

Guide bushing

▲ WARNING - WEAR SAFETY GLASSES

Watch out for the spring when release the screw driver after remove the e-clip.

3. Remove the E-clips from groove using the slot screw driver.

Figure 5 Remove E-Clips

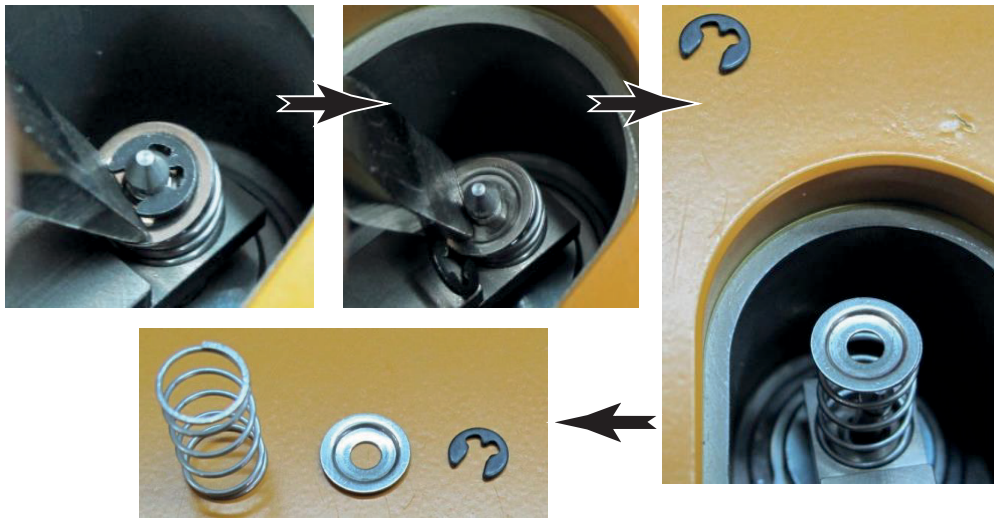

4. Take out the feed back mechanism. The plastic adjustment screws are under the feed back mechanism.

Figure 6 Remove feedback mechanism

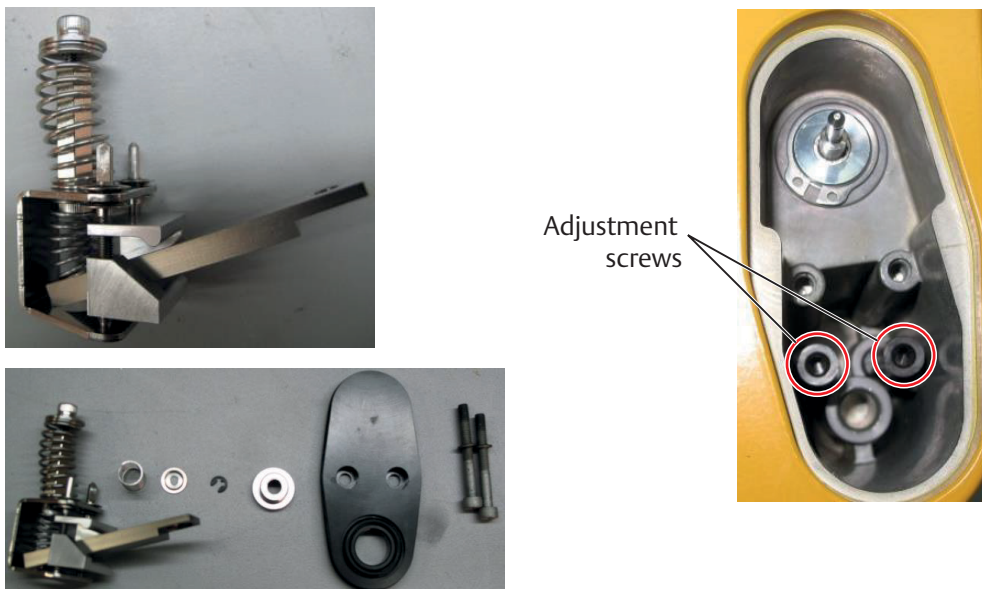

5. Punch the plastic screws from bottom until they are free to be removed from the top.

Figure 7 Remove the adjustment screws

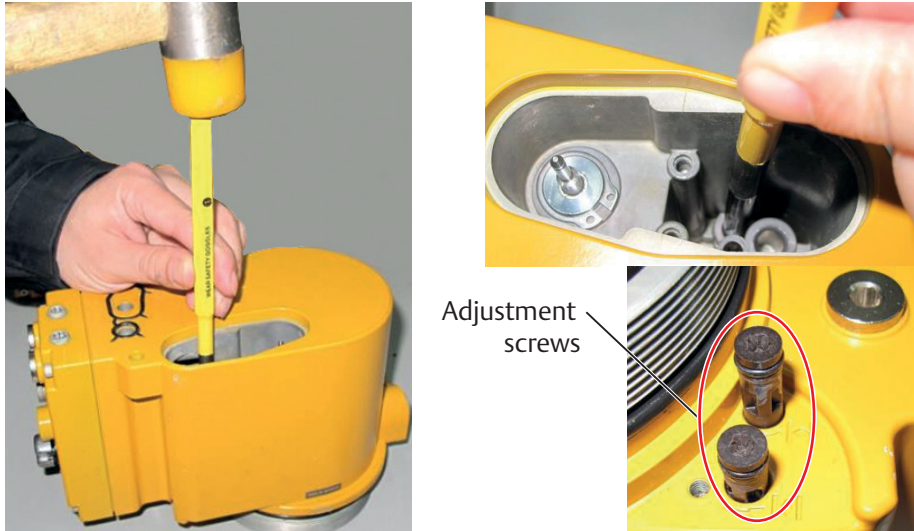

3 Reassembly procedure

IMPORTANT

Check before replacing that both plastic adjustment screws have two O-rings in the top and bottom groove.

1. Mount the new adjustment screws and press them down until they are flush with the body.

Figure 8 Mount the new adjustment screws

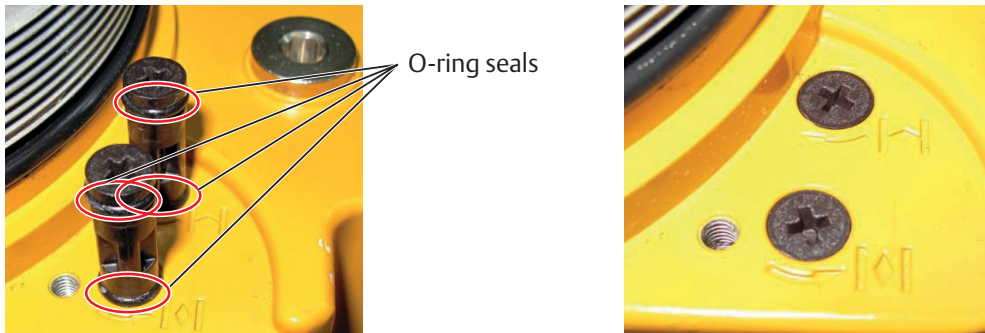

2. Adjust the orientation of the heads of setting screws of the feedback mechanism to match the direction of new adjustment screws.

Figure 9 Adjust the orientation of the heads of setting screws

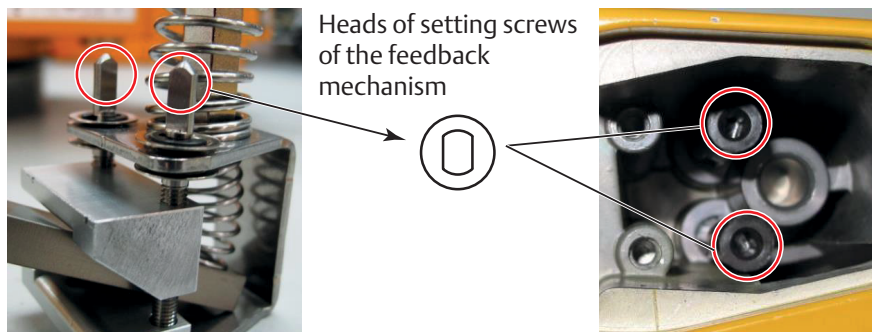

3. Place the feedback mechanism back into housing. The mechanism can be pressed down to the same level of the machined surface if the rotation of the screw and plastic are matched in step 2.
4. Place the spring back and put the washer on, make sure the direction of washer is correct so that the E-clip can sit in.

Figure 10 Place the feedback mechanism back

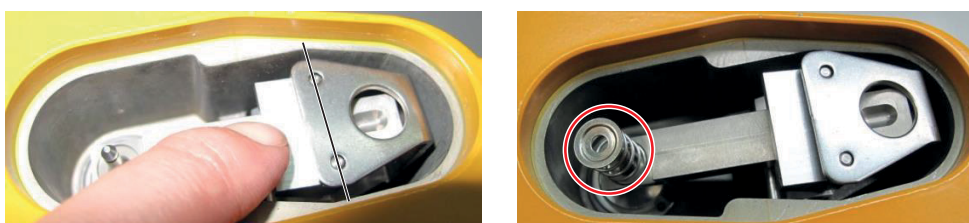

▲ WARNING - WEAR SAFETY GLASSES

Wear safety glasses when compressing the spring.
Release your fingers slowly after mounting the e-clip.
Try a different angle if you fail to compress the spring and washer.

5. Press the spring with spring washer down until the groove and the switch operating rod is visible.
6. Use the e-clip tool to mount the e-clip in the groove.

Figure 11 Mount the E-clip

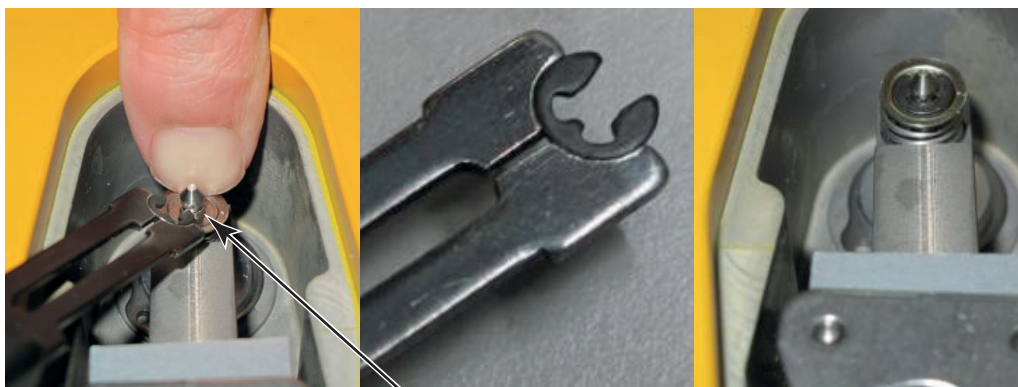

Groove on switch operating rod.

7. Place back the bushing and mount the cover back in place. Tighten the screws with 8.85 lbf.in (0.73 lbf.ft or 1 Nm) of torque.

IMPORTANT

Make sure that the bound seals are in place when mounting the cover screws.

Figure 12 Place back the bushing and mount the cover

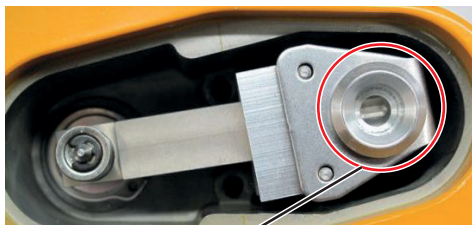

Guide bushing

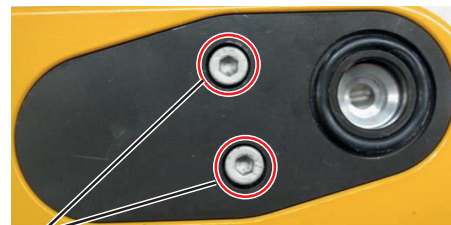

Make sure that the bound seals are in place when mounting the cover screws

4 Adjusting the switch points

In order to prevent damage again to the adjustment screws or feed back mechanism, we strongly recommend to follow the instruction for switch point adjustment as per section 5 of the installation guides as shipped with each Control Module.

Additionally for below control modules, “Step-By-Step” setting instruction sheets are available.

Control modules	Brand	Installation guide	"Step-By-Step" setting instruction
QC41, QC42 and QC43	FieldQ	DOC.IG.QC41.1	DOC.SAI.QC41.EN
QC40 ASI	FieldQ	DOC.IG.QC40.1	DOC.SAI.QC40.EN
QC41, QC42 and QC43	Bettis Q-Series	DOC.IG.BQC41.1	DOC.SAI.QC41.EN
QC40 ASI	Bettis Q-Series	DOC.IG.BQC40.1	DOC.SAI.QC40.EN

World Area Configuration Centers (WACC) offer sales support, service, inventory and commissioning to our global customers. Choose the WACC or sales office nearest you:

NORTH & SOUTH AMERICA

19200 Northwest Freeway
Houston TX 77065
USA
T +1 281 477 4100

Av. Hollingsworth
325 Iporanga Sorocaba
SP 18087-105
Brazil
T +55 15 3413 8888

ASIA PACIFIC

No. 9 Gul Road
#01-02 Singapore 629361
T +65 6777 8211

No. 1 Lai Yuan Road
Wuqing Development Area
Tianjin 301700
P. R. China
T +86 22 8212 3300

MIDDLE EAST & AFRICA

P. O. Box 17033
Jebel Ali Free Zone
Dubai
T +971 4 811 8100

P. O. Box 10305
Jubail 31961
Saudi Arabia
T +966 3 340 8650

24 Angus Crescent
Longmeadow Business Estate East
P.O. Box 6908 Greenstone
1616 Modderfontein Extension 5
South Africa
T +27 11 451 3700

EUROPE

Holland Fasor 6
Székesfehérvár 8000
Hungary
T +36 22 53 09 50

Strada Biffi 165
29017 Fiorenzuola d'Arda (PC)
Italy
T +39 0523 944 411

For complete list of sales and manufacturing sites, please visit www.emerson.com/actuationtechnologieslocations or contact us at info.actuationtechnologies@emerson.com

www.emerson.com/bettis

©2018 Emerson. All rights reserved.

The Emerson logo is a trademark and service mark of Emerson Electric Co. Bettis™ is a mark of one of the Emerson family of companies. All other marks are property of their respective owners.

The contents of this publication are presented for information purposes only, and while every effort has been made to ensure their accuracy, they are not to be construed as warranties or guarantees, express or implied, regarding the products or services described herein or their use or applicability. All sales are governed by our terms and conditions, which are available on request. We reserve the right to modify or improve the designs or specifications of our products at any time without notice.

