

Rosemount™ 2410 Tank Hub

Whessoe emulation instruction



Contents

Chapter 1	Introduction.....	5
	1.1 Emulation capabilities.....	6
	1.2 Whessoe system characteristics.....	7
	1.3 Rosemount 2410 Tank Hub communication.....	8
Chapter 2	Electrical installation.....	13
	2.1 Rosemount 2410 Tank Hub connections.....	13
Chapter 3	Configuration.....	15
	3.1 Set up Modbus communication protocol.....	15
	3.2 Install Rosemount 2410 Tank Hub in WinSetup.....	16
	3.3 Configure specific variables for emulation.....	18
	3.4 Verify Whessoe communication parameters.....	21
	3.5 Configure field devices.....	23
	3.6 Start Whessoe emulation.....	23
Chapter 4	Troubleshooting.....	25
	4.1 Communication status.....	25
	4.2 Digital current loop modem.....	26
Chapter 5	Optional configuration and settings.....	27
	5.1 Engineering units.....	27
	5.2 Miscellaneous control register.....	27
	5.3 Alarms.....	29

1 Introduction

The purpose of this document is to provide guidelines on how to change from other manufacturer's devices to Rosemount equipment by exchanging gauges. When a gauge is replaced with a Rosemount gauge, it is necessary to configure the Rosemount 2410 Tank Hub for emulation.

The Rosemount field devices, for example Rosemount 5900 Radar Level Gauge and Rosemount 2240S Temperature Transmitter, are connected to the tank hub using the intrinsically safe Tankbus as usual. Emulation is done in the tank hub only. Each tank hub can emulate up to 10 tanks (10 separate gauges)⁽¹⁾.

Figure 1-1: Rosemount Devices Replacing Old Gauges in an Existing Whessoe System

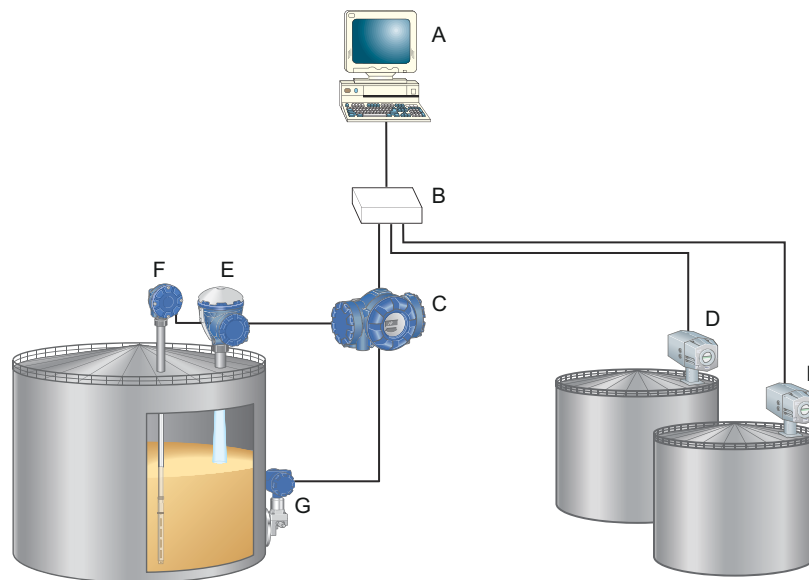

- A. Existing Whessoe host
- B. Existing data polling unit
- C. Rosemount 2410 Tank Hub
- D. Whessoe gauges
- E. Rosemount 5900S Radar Level Gauge
- F. Rosemount 2240S Temperature Transmitter with sensor
- G. Rosemount 3051S Pressure Transmitter

(1) Tank hub version "Multiple tanks" can emulate up to 10 tanks (10 gauges). Tank hub version "Single tank" can emulate up to 2 tanks (2 gauges).

1.1 Emulation capabilities

Emulation enables the replacement of old devices with Rosemount devices in another vendor's existing tank gauging system. The Rosemount device will perform just like the replaced gauge, using the other vendor's protocol to communicate.

By using the other vendor's field and control room communication protocol with modern Rosemount tank gauging devices, the legacy system can be modernized step-by-step. The legacy system can be upgraded while tanks are in operation and existing wiring can be re-used.

The tank hub can emulate replaced devices, acting as either slave or master⁽²⁾. The tank hub slave emulation is described in this document.

Tank hub acting as slave

When an old gauge from another vendor is replaced with a tank hub connected to a Rosemount field device, the tank hub will act as a slave answering requests and sending data upwards towards the host.

A stepwise "bottom-up" upgrade is done by replacing legacy gauges to begin with, and changing the complete control system at a later occasion.

Figure 1-2: Tank Hub Slave Emulation

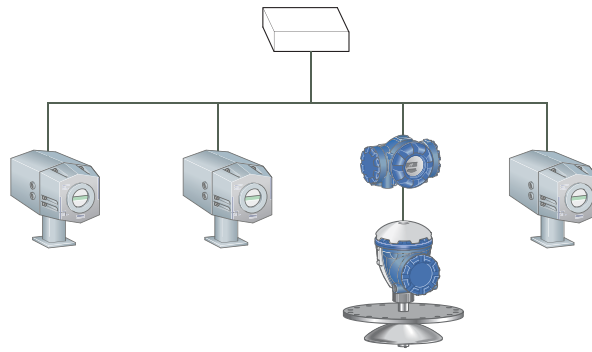

⁽²⁾ Tank hub master emulation is supported for the Whessoe 550 protocol. For further information about Whessoe master emulation contact your Emerson Automation Solutions/Rosemount Tank Gauging representative.

1.2 Whessoe system characteristics

A typical Whessoe tank gauging system consists of a number of field devices such as level, temperature, and pressure devices. The Rosemount 2410 Tank Hub supports the Whessoe protocols WM550 and WM660. The electrical interface can be either digital current loop or RS485, see [Table 1-1](#).

Table 1-1: Whessoe Protocol Options

Protocol	Electrical interface
WM550	Digital current loop (DCL)
WM660	Digital current loop (DCL)
	RS485

Figure 1-3: Whessoe Connection: Digital Current Loop - Devices Connected in Series

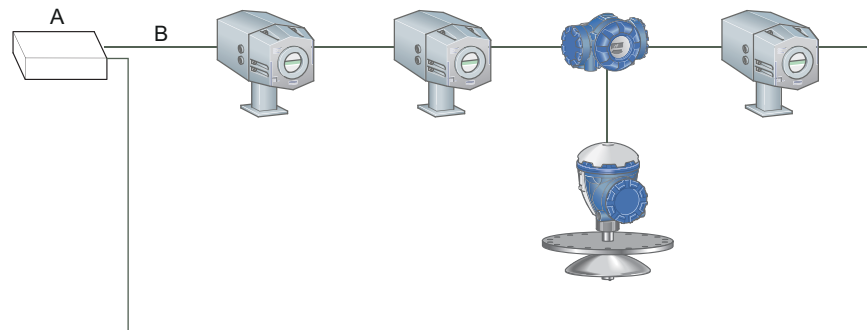

- A. Whessoe master
- B. 0-20 mA

Figure 1-4: Whessoe Connection: RS485 - Devices Connected in Parallel

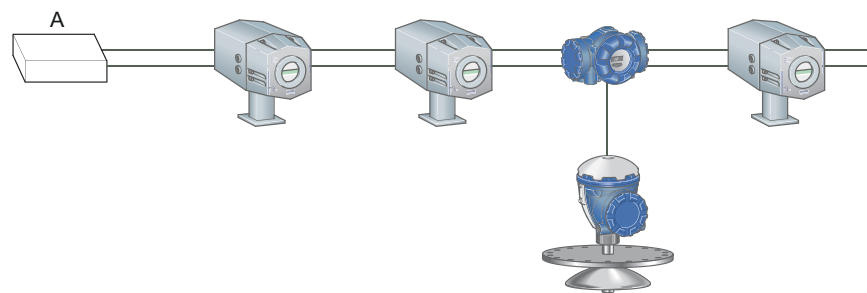

- A. Whessoe master

1.3 Rosemount 2410 Tank Hub communication

The tank hub has slots for two independent communication boards, primary and secondary field bus, for TRL2 Modbus®, RS485 Modbus, emulation, or wireless communication.

Support for Whessoe emulation is selected in the model code, refer to Rosemount 2410 [Product Data Sheet](#) for more information. There are three alternatives available for Whessoe emulation:

- [Example 1: RS485 Modbus on primary bus](#)
RS485 is available on the primary bus, preferably combined with TRL2 on the secondary bus.
- [Example 2: Digital current loop on Secondary Fieldbus](#)
Whessoe (digital current loop) is available on the secondary bus, where the primary bus can be used for regular TRL2 or RS485 communication.
- [Example 3: Wireless communication in combination with Whessoe emulation](#)
RS485 or Whessoe (digital current loop) is available on the primary bus, where the secondary bus is used for *WirelessHART*® for normal communication.

Example 1: RS485 Modbus on primary bus

When the RS485 protocol is used for Whessoe emulation, the primary field bus is connected to the Whessoe host. The secondary field bus can be used to configure the tank hub for emulation, using a TRL2 modem like the Rosemount 2180 Field Bus Modem (FBM), see [Figure 1-5](#).

Figure 1-5: Emulation on Primary Bus and Configuration on Secondary Bus

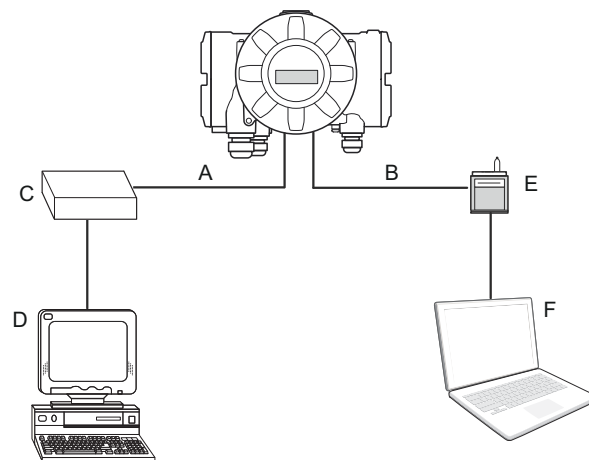

- A. Primary bus: RS485 Modbus
- B. Secondary bus: TRL2 Modbus
- C. RS485 converter
- D. Whessoe host
- E. FBM
- F. Rosemount TankMaster™ PC

It is possible to use the RS485 protocol for both emulation and configuration⁽³⁾. In that case, the primary bus is first used for configuration and thereafter switched to the Whessoe host in order to start emulation, as shown in [Figure 1-6](#).

Figure 1-6: Emulation and Configuration on Primary Bus

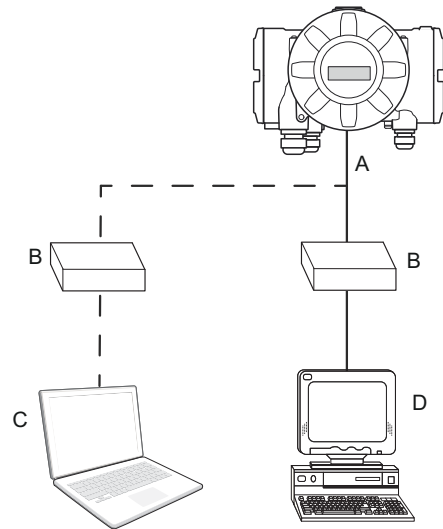

- A. Primary bus: RS485 Modbus
- B. RS485 converter
- C. Rosemount TankMaster™ PC
- D. Whessoe host

⁽³⁾ When using the RS485 protocol for configuring, different communication parameters must be used. See [Table 3-1](#).

Example 2: Digital current loop on Secondary Fieldbus

The digital current loop interface is connected to the Rosemount 2410 secondary field bus.

Configuration is usually performed with a FBM connected to the primary bus. The primary bus can be used for regular TRL2 or RS485 Modbus communication.

Figure 1-7: Configuration on Primary Bus and Emulation on Secondary Bus

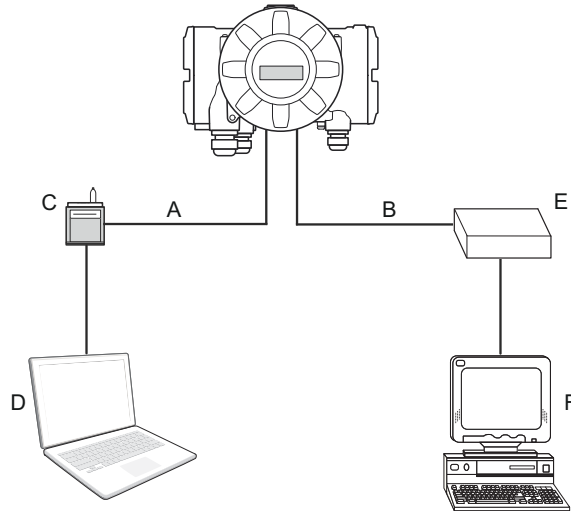

- A. Primary bus: TRL2 Modbus
- B. Secondary bus: Digital current loop
- C. FBM
- D. Rosemount TankMaster™ PC
- E. DCL modem
- F. Whessoe host

Example 3: Wireless communication in combination with Whessoe emulation

The tank hub supports Emerson's wireless technology, which is based on *WirelessHART*, the emerging industry standard for wireless field networks. The Emerson Wireless THUM™ Adapter acts as a wireless data link between the tank hub and an Emerson Wireless Gateway.

The tank hub can simultaneously combine wireless and Whessoe communication. The primary field bus communicates via digital current loop or RS485 Modbus, and the secondary field bus via *WirelessHART*. With this tank hub communication configuration, control room redundancy is achieved.

Figure 1-8: Emulation on Primary Fieldbus and Wireless Communication on Secondary Field Bus

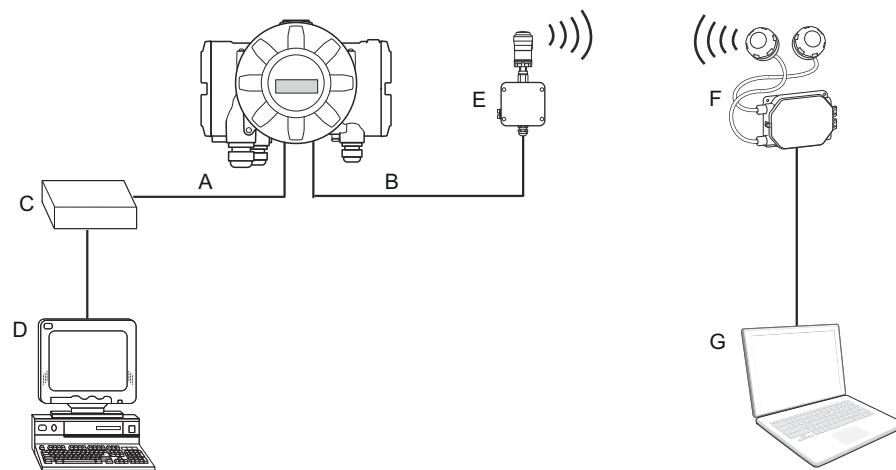

- A. Primary bus: Digital current loop or RS485 Modbus
- B. Secondary bus: WirelessHART
- C. DCL modem or RS485 converter
- D. Whessoe host
- E. Emerson Wireless THUM Adapter
- F. Emerson Wireless Gateway
- G. Rosemount TankMaster PC

2 Electrical installation

2.1 Rosemount 2410 Tank Hub connections

Figure 2-1: Terminal Block in the Explosion-Proof/Flameproof Compartment

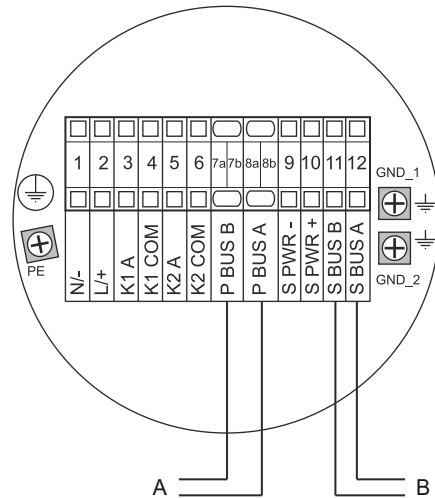

- A. Primary field bus
- B. Secondary field bus

Table 2-1: Terminal Assignment for Non-Intrinsically Safe Side

Terminal	Designation	Function
1	N/-	Power, Neutral / DC -
2	L/+	Power, Line / DC +
3	K1 A	Relay 1 output (optional). Hardware configurable NO/NC.
4	K1 com	Relay 1 common
5	K2 A	Relay 2 output (optional). Hardware configurable NO/NC.
6	K2 com	Relay 2 common
7a/7b ⁽¹⁾	P Bus B	Primary communication bus RS485 B Primary communication bus DCL -
8a/8b ⁽¹⁾	P Bus A	Primary communication bus RS485 A Primary communication bus DCL +
9	S Pwr -	Secondary bus power - (N/A)
10	S Pwr +	Secondary bus power + (N/A)
11 ⁽¹⁾	S Bus B	Secondary communication bus DCL -
12 ⁽¹⁾	S Bus A	Secondary communication bus DCL +

Table 2-1: Terminal Assignment for Non-Intrinsically Safe Side (continued)

Terminal	Designation	Function
PE	PE	Power supply protective ground
GND_1	GND_1	Housing chassis/shield Primary bus
GND_2	GND_2	Housing chassis/shield Secondary bus

(1) Refer to [Electrical drawings](#) for additional information.

Electrical drawings

- RS485: [Electrical Installation Drawing \(D9240041-952\)](#)
- Digital current loop/Wireless: [Electrical Installation Drawing \(D7000006-457\)](#)
- Digital current loop on secondary bus: [Electrical Installation Drawing \(D7000002-526\)](#)

3 Configuration

The Rosemount 2410 Tank Hub is configured by using the TankMaster WinSetup configuration program⁽⁴⁾. WinSetup is a user-friendly software package that includes basic configuration options as well as advanced configuration and service functions.

Configuration of the Rosemount 2410 emulation function can be performed with the WinSetup program using the FBM or a RS485 converter, depending on the tank hub configuration. A tank hub where the secondary field bus communicates via WirelessHART®, can be configured by wireless communication with an Emerson Wireless Gateway.

3.1 Set up Modbus communication protocol

This section describes how to configure the Modbus Master protocol channel for communication. To specify PC communication port and the standard communication parameters, do the following:

Procedure

1. Open the **Protocols** folder in the *TankMaster WinSetup* workspace window.
2. Select the **Modbus Master** icon.

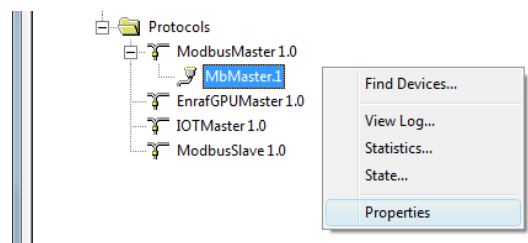

3. Right click the proper **MBMaster** icon and select **Properties** to configure the protocol channel.
4. Select the **Communication** tab.

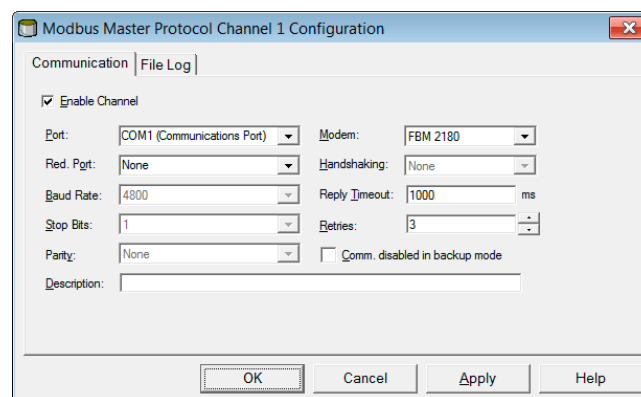

⁽⁴⁾ See the Rosemount Tank Gauging System [Configuration Manual](#) for more information on how to use the TankMaster WinSetup software to configure the Rosemount 2410 Tank Hub.

- Set the communication parameters:

Table 3-1: Communication Parameters

	FBM	RS485 converter
Port	The COM port the FBM is connected to	The COM port the converter is connected to
Baud rate	4800	9600
Stop bits	1	1
Parity	None	None
Modem	FBM 2180	RS-485
Handshaking	None	RTS/CTS
Reply timeout	1000 ms	1000 ms
Retries	3	3
Description	Text describing the configured channel	Text describing the configured channel

- Select the **Enable Channel** check box to activate the protocol channel.
- Select **OK** to store the current configuration and close the configuration window.

3.2 Install Rosemount 2410 Tank Hub in WinSetup

The TankMaster WinSetup wizard is the recommended tool for installing the tank hub. The installation wizard manages basic configuration of the tank hub.

Perform the following steps to start the installation wizard in TankMaster WinSetup:

Procedure

- In the *TankMaster WinSetup* workspace window select the **Devices** folder.

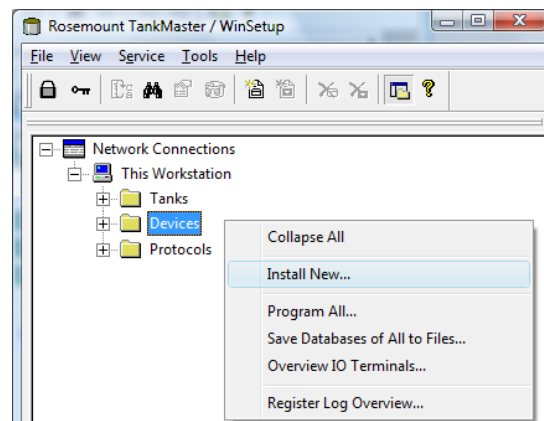

- Right click and select **Install New** or, from the **Service** menu, select the **Devices/Install New** option. The *Select Device* window opens.

- From the **Device Type** drop-down list, select the **2410 Tank Hub** option.

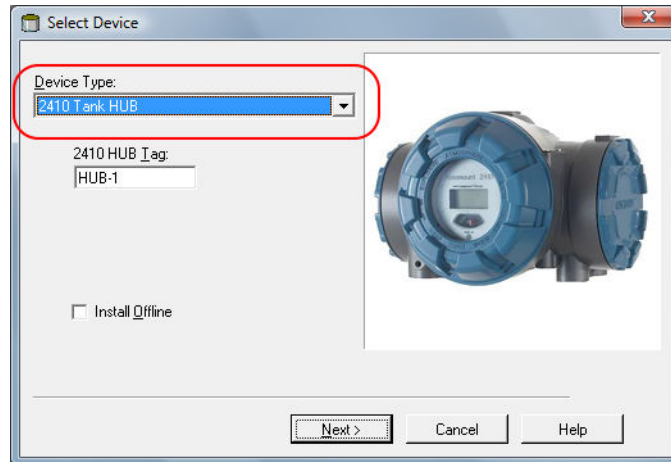

- Type a name in the **2410 HUB Tag** field. The 2410 Hub Tag will be used as an identifier for the tank hub in various windows and dialogs.
- Select **Next**. The **2410 Tank Hub Communication** window opens.
- Ensure TankMaster communicates directly with the tank hub and that the proper communication channel is chosen.

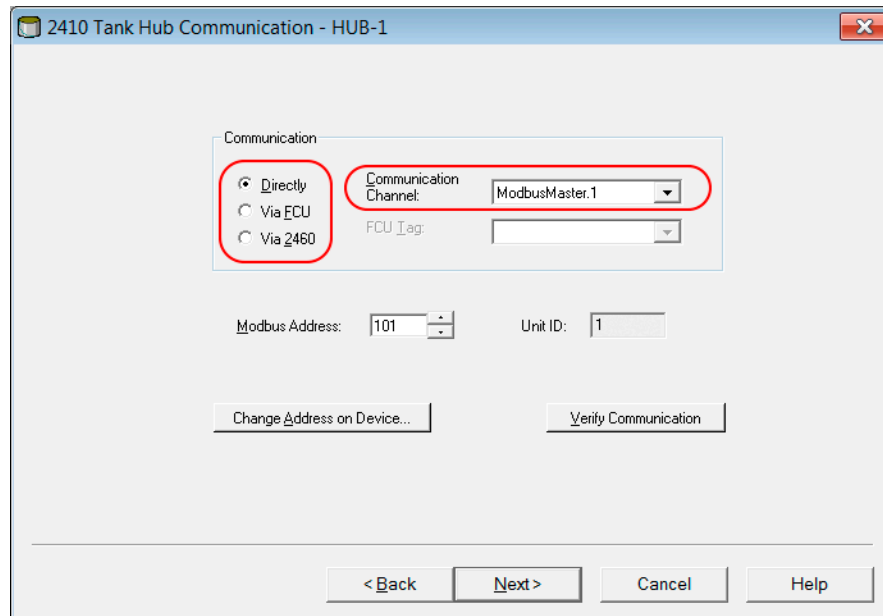

- Default Modbus Address is 247 for the tank hub. It is recommended to change it to an address between 101-199. To change the address, do the following:

- a) In the **2410 Tank Hub Communication** window select **Change Address on Device...** to open the **Change Address** window.

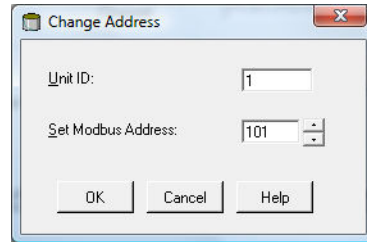

- b) Enter the **Unit ID** and select the new Modbus Address. When changing the device address, the Unit ID is used as a unique identifier of the device. The Unit ID can be found on a label mounted on the device.
 - c) Select **OK** to confirm the address settings and close the **Change Address** window.
 - d) In the **2410 Tank Hub Communication** window select **Verify Communication** to check that communication is established between the TankMaster work station and the tank hub. The **Unit ID** will appear when TankMaster detects the tank hub.
8. In the **2410 Tank Hub Communication** window select **Next** to continue the installation procedure of the tank hub.
 9. Continue configuration of the tank hub following the standard installation procedure.

3.3 Configure specific variables for emulation

The tank hub holding registers are used to configure the Whessoe emulation variables.

Procedure

1. In the **TankMaster WinSetup** workspace window, right click the tank hub device icon.
2. To view the holding registers, select the **View Holding Registers** option.

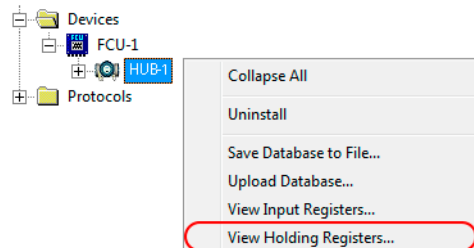

3. Enable Whessoe emulation by selecting the Whessoe protocol in holding register 700 (RS485) or holding register 750 (digital current loop).
 - a) Double-click the grey colored Value field.

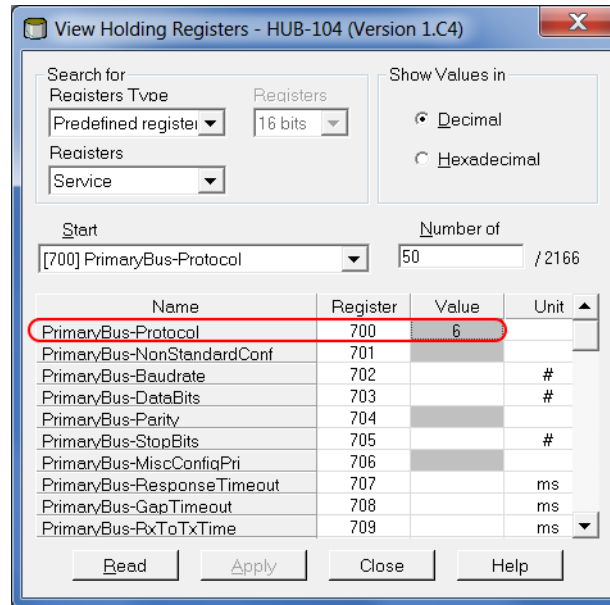

- b) From the drop-down menu select **Whessoe** and then select the **OK** button. The value 6 will appear in the **Value** field when the Whessoe protocol is selected.

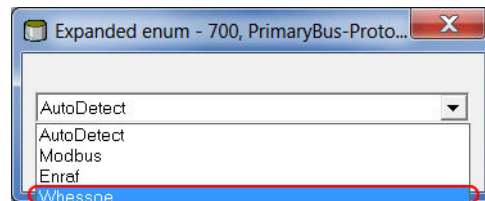

Note

When replacing a Whessoe gauge with a Rosemount device, the Rosemount device must have the same Whessoe address as the gauge being replaced.

- Enter the required emulation address in holding registers 900-909. Valid Whessoe addresses are 0-31 for WM550, and 0-255 for WM660.⁽⁵⁾

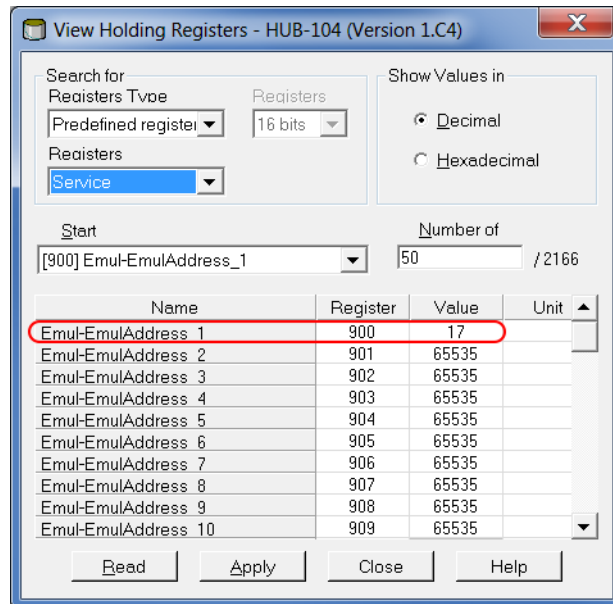

Enter required emulation address in the **Value** field.

Tip

In the **Tank Database** tab, set the Modbus address to the same as the chosen Whessoe address for each device.

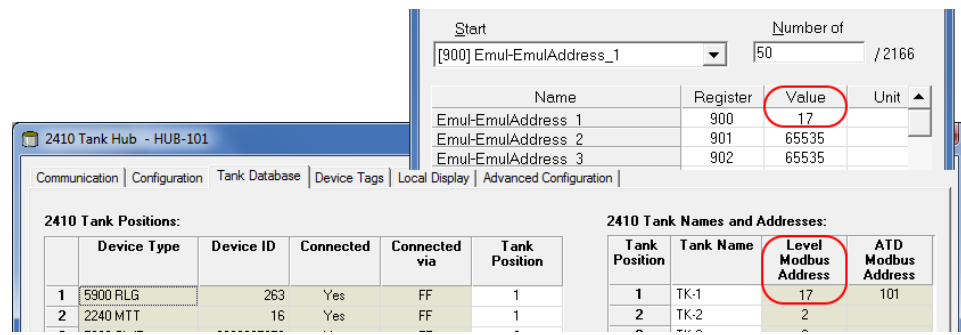

⁽⁵⁾ Emulation address is by default set to “65535” for tank positions that are not in use.

5. Select Whessoe protocol in holding register 1040.
 - a) Double-click the grey colored Value field.

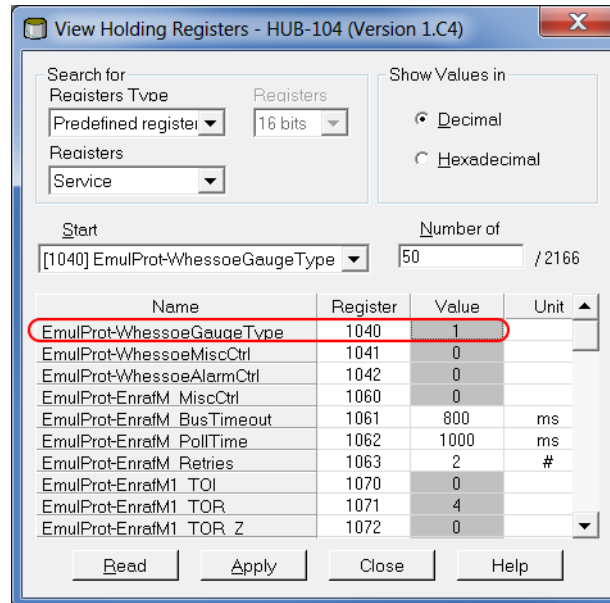

- b) From the drop-down menu select desired Whessoe protocol, and select the OK button.

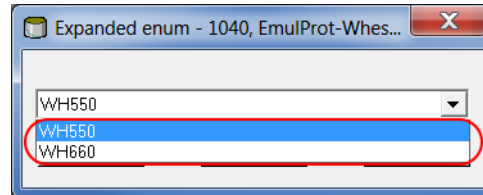

Related information

[Optional configuration and settings](#)

3.4 Verify Whessoe communication parameters

Once Whessoe emulation is selected (see [Step 3](#)), the Whessoe emulation communication parameters is automatically configured to default values:

Baud rate	2400
Data bits	8
Parity	Even
Start bit	1
Stop bit	1

Procedure

To change the communication parameters (optional), do the following:

- a) In the **Workspace** window, right click the Rosemount 2410 icon and select **Properties**. Select the **Configuration** tab, and continue by selecting the **Primary Bus** button or the **Secondary Bus** button, depending on your model code options.
- b) From the **Configuration** drop-down list select **Non Standard**.

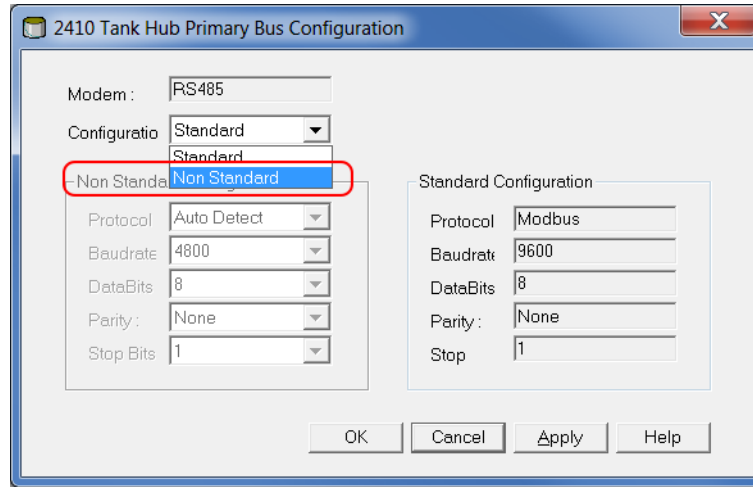

- c) From the **Protocol** drop-down list select protocol **WM550** or **WM660**.

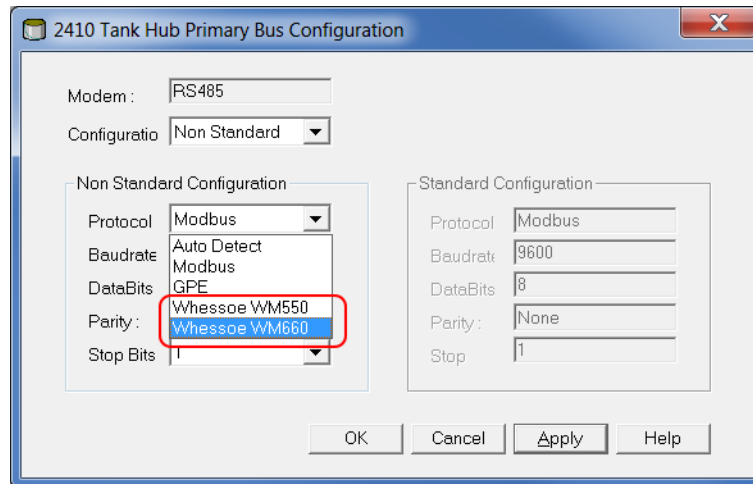

- d) Specify the communication parameters according to the Whessoe tank gauging system characteristics.

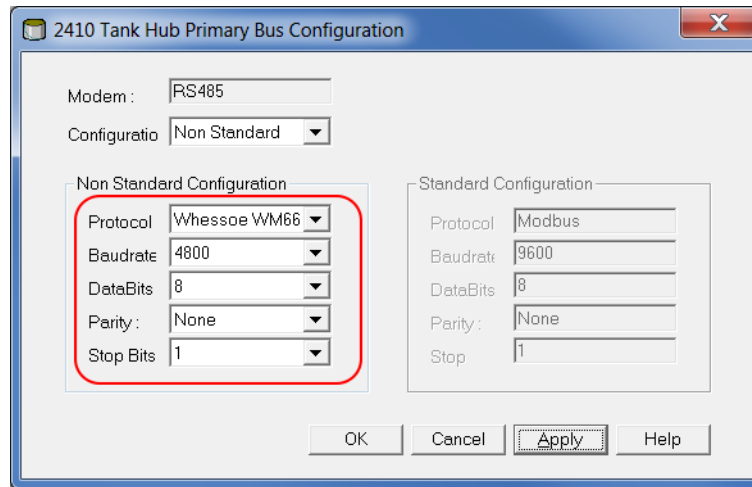

3.5 Configure field devices

When the tank hub configuration is completed, the Rosemount field devices, for example Rosemount 5900 Radar Level Gauge or Rosemount 2240S Multi-input Temperature Transmitter, must be configured as well. The field devices are configured as usual, for further information see the Rosemount Tank Gauging System [Configuration Manual](#).

Procedure

1. Configure the field devices by using the *Properties* window of each device.
2. Verify that level and temperature values are valid.

3.6 Start Whessoe emulation

3.6.1 Tank hub with primary and secondary field bus

Procedure

1. If not already connected, connect the tank hub to the Whessoe host.
2. The tank hub will now act like a Whessoe gauge.

3.6.2 Tank hub with primary field bus

Procedure

1. When the tank hub configuration is completed, disconnect TankMaster.
2. Connect the tank hub to the Whessoe host.
3. The tank hub will now act like a Whessoe gauge.

4 Troubleshooting

4.1 Communication status

Table 4-1: Troubleshooting Chart

Problem	Cause
No communication with Rosemount 2410 using TRL2 bus.	<ol style="list-style-type: none"> 1. Incorrect Modbus address. 2. Incorrect communication parameter settings. Check LCD Display during startup, for used settings.
No response from Rosemount 2410 using the Whessoe bus.	<ol style="list-style-type: none"> 1. Whessoe address is not the same as configured in Rosemount 2410, emulation address. 2. Bad cabling. 3. Whessoe bus baud rate is not the same as configured in Rosemount 2410. 4. Whessoe bus stop bit configuration is not the same as configured in Rosemount 2410. 5. Incorrect Whessoe protocol selected in Rosemount 2410. 6. Whessoe emulation is not enabled. 7. Incorrect modem is installed in the Rosemount 2410. 8. Rosemount 2410 software is older than 1.B2.
No relay status is available in the host.	<ol style="list-style-type: none"> 1. The AlarmStatus register is not correctly configured (holding register 1042). 2. Relay K1 or K2 are not correctly configured in Rosemount 2410.
Pressure is indicated to be invalid.	<ol style="list-style-type: none"> 1. The pressure source is not correctly configured. Check the pressure value on the LCD Display or in the Standard Input registers for TMV Pressure.

Check message status

Verify that communication is working properly by checking the input registers as described in [Table 4-2](#). See [Table 4-3](#) for troubleshooting actions.

Table 4-2: Messages Input Registers

Register number		Input register	Description
Primary bus	Secondary bus		
1206	1256	RecMessages	Total queries received
1208	1258	MessagesToMe	Number of received queries addressed to me
1210	1260	SentMessages	Number of sent messages

Table 4-3: Messages Troubleshooting Chart

Symptom	Action
Input register RecMessages does not enumerate	Check that: <ul style="list-style-type: none"> the tank hub is powered. cables are properly connected. the tank hub is in Whessoe mode. the tank hub is configured for Whessoe emulation.
Input register MessagesToMe does not enumerate	Check that the Whessoe address is correct.
Input register SentMessages does not enumerate	Check that the host is sending proper requests

4.2 Digital current loop modem

Check LEDs

If the tank hub is mounted in a safe zone, it is possible to use the LEDs on the DCL modem for trouble shooting. Dismount the front cover to discover the red and green LEDs:

- Red LED: Always on, flashing when the Rosemount 2410 is transmitting.
- Green LED: On when there is 20 mA in the loop.

Note

The tank hub front cover must only be dismounted in a safe zone.

5 Optional configuration and settings

5.1 Engineering units

Level and temperature units

Engineering units are not separately configured for Whessoe emulation:

- Length unit is mm despite the tank hub unit configuration.
- Average temperature unit is Celsius despite the tank hub unit configuration.

Level in percentage

The Whessoe protocol supports level in percent of range. The value is automatically calculated for the applicable tank. No special configuration of the Rosemount 2410 is required.

5.2 Miscellaneous control register

Holding register 1041 (MiscControl) is used to set some optional configuration bits, refer to [Table 5-1](#).

Table 5-1: Holding Register WhessoeMiscControl (1041) Bits

Bit	Name	Default value	Definition
5	Liquid pressure	0x0	Whessoe Task 30 ⁽¹⁾ includes pressure. The normal pressure is vapor (gas) pressure. By setting bit 5, the pressure is changed to liquid pressure.
6	High resolution pressure	0x0	The Whessoe Task 30 ⁽¹⁾ supports a 8-bit pressure value (0-255). Five bits are unused in the response. By setting bit 6, the five bits are activated and included in the pressure value. The high resolution pressure value will then include 13-bits (0-8191). Note that this is not Whessoe standard.
7	Task 32 for 2410	0x0	By setting bit 7, the Rosemount 2410 software date is used in the Whessoe Task 32 ⁽¹⁾ response.

(1) Type of request for the Whessoe protocol.

To set optional configuration bits using holding register 1041 (MiscControl), do the following:

Procedure

1. Double-click the grey colored Value field.

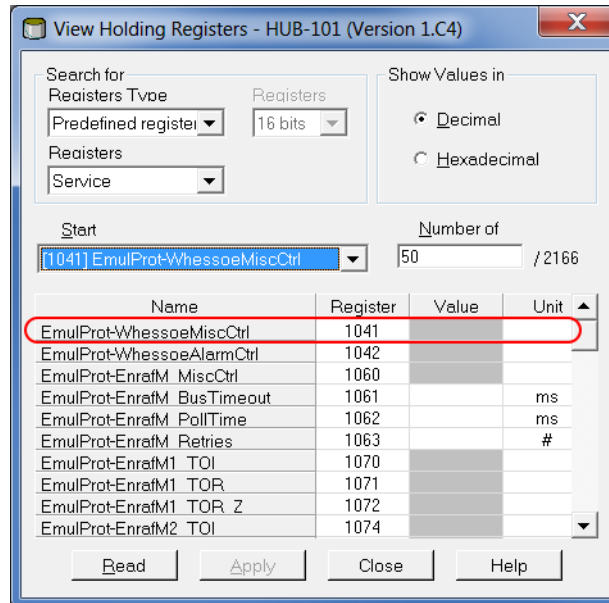

2. In the *Expanded Bitfield - 1041, EmulProt-Wh...* window, double-click the Value field to enable/disable each option.

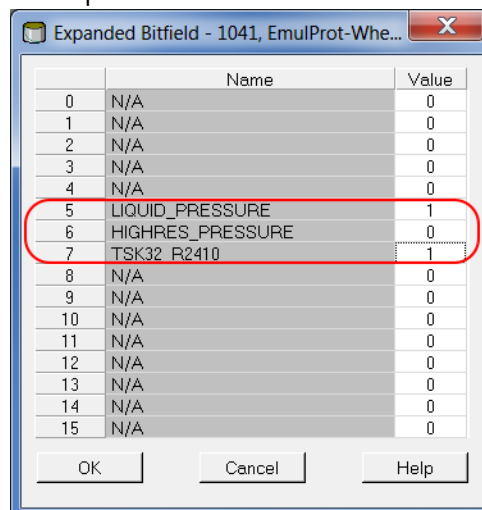

5.3 Alarms

5.3.1 Alarm limit configuration

The level alarm limits are configured in the holding register block TMVAlarm-AlarmLevelLimit 2400-2478.

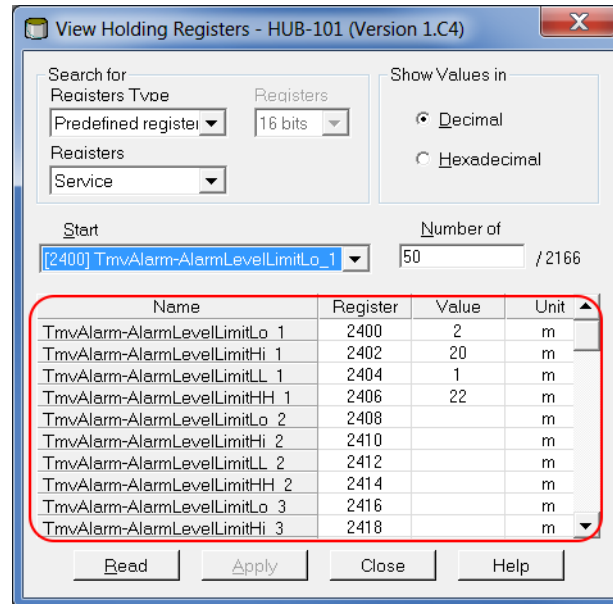

5.3.2 Alarm configuration

WM550

There are four alarm bits available in the WM550 protocol Task 04 response:

- Alarm 1: Relay K1
- Alarm 2: Level high alarm
- Alarm 3: Level low alarm
- Alarm 4: Relay K2

Use holding register 1042 to individually enable/disable the WM550 alarm bits:

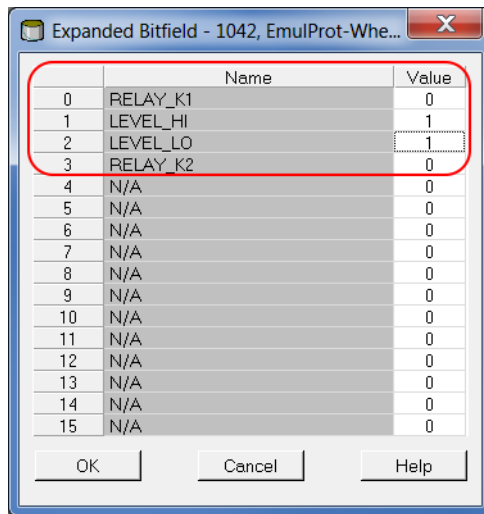

	Name	Value
0	RELAY_K1	0
1	LEVEL_HI	1
2	LEVEL_LO	1
3	RELAY_K2	0
4	N/A	0
5	N/A	0
6	N/A	0
7	N/A	0
8	N/A	0
9	N/A	0
10	N/A	0
11	N/A	0
12	N/A	0
13	N/A	0
14	N/A	0
15	N/A	0

WM660

The Modbus read request receives the status of the alarms from the tank hub registers:

- Alarm 1: Level HH Alarm
- Alarm 2: Level High Alarm
- Alarm 3: Level Low Alarm
- Alarm 4: Level LL Alarm

For more information: www.emerson.com

©2022 Emerson. All rights reserved.

Emerson Terms and Conditions of Sale are available upon request. The Emerson logo is a trademark and service mark of Emerson Electric Co. Rosemount is a mark of one of the Emerson family of companies. All other marks are the property of their respective owners.

ROSEMOUNT™

