

Rosemount™ 3051 Pressure Transmitter

with PROFIBUS® PA Protocol



Safety messages

Procedures and instructions in this section may require special precautions to ensure the safety of the personnel performing the operations. Information that raises potential safety issues is indicated by a warning symbol () . Refer to the following safety messages before performing an operation preceded by this symbol.

NOTICE

Read this manual before working with the product. For personal and system safety, and for optimum product performance, make sure you thoroughly understand the contents before installing, using, or maintaining this product. For technical assistance, contacts are listed below:

Customer Central Technical support, quoting, and order-related questions.

United States - 1-800-999-9307 (7:00 am to 7:00 pm CST)

Asia Pacific- 65 777 8211

Europe/ Middle East/ Africa - 49 (8153) 9390

North American Response Center Equipment service needs.

1-800-654-7768 (24 hours—includes Canada)

Outside of these areas, contact your local Emerson representative.

CAUTION

The products described in this document are NOT designed for nuclear-qualified applications. Using non-nuclear qualified products in applications that require nuclear-qualified hardware or products may cause inaccurate readings.

For information on Rosemount nuclear-qualified products, contact your local Emerson Process Management Sales Representative.

WARNING

Explosions could result in death or serious injury.

Installation of this transmitter in an explosive environment must be in accordance with the appropriate local, national, and international standards, codes, and practices. Review the approvals section of this Reference Manual for any restrictions associated with a safe installation.

In an explosion-proof/flameproof installation, do not remove the transmitter covers when power is applied to the unit.

Process leaks could result in death or serious injury.

Install and tighten process connectors before applying pressure.

Electrical shock could cause death or serious injury.

Avoid contact with the leads and terminals. High voltage that may be present on leads can cause electrical shock.

WARNING

Physical access

Unauthorized personnel may potentially cause significant damage to and/or misconfiguration of end users' equipment. This could be intentional or unintentional and needs to be protected against.

Physical security is an important part of any security program and fundamental to protecting your system. Restrict physical access by unauthorized personnel to protect end users' assets. This is true for all systems used within the facility.

Contents

Chapter 1	Introduction.....	5
	1.1 Using this manual.....	5
	1.2 Models covered.....	6
	1.3 Device revisions.....	7
	1.4 Transmitter overview.....	7
	1.5 Product recycling/disposal.....	7
Chapter 2	Configuration.....	9
	2.1 Section overview.....	9
	2.2 Safety messages.....	9
	2.3 Hazardous locations certifications.....	9
	2.4 Configuration guidelines.....	9
	2.5 Basic setup tasks.....	11
	2.6 Detailed setup tasks.....	13
Chapter 3	Hardware Installation.....	21
	3.1 Section overview.....	21
	3.2 Safety messages.....	21
	3.3 Considerations.....	21
	3.4 Installation procedures.....	22
	3.5 Rosemount 305, 306, and 304 manifolds.....	35
	3.6 Liquid level measurement.....	46
Chapter 4	Electrical Installation.....	51
	4.1 Section overview.....	51
	4.2 Safety messages.....	51
	4.3 LCD display	52
	4.4 LCD display with local operator interface (LOI).....	52
	4.5 Configure security and simulation.....	52
	4.6 Electrical considerations.....	53
Chapter 5	Calibration.....	61
	5.1 Section overview.....	61
	5.2 Safety messages.....	61
	5.3 Calibration overview.....	61
	5.4 Determining calibration frequency.....	62
	5.5 Zero trim.....	63
	5.6 Sensor trim.....	64
	5.7 Recall factory trim.....	65
	5.8 Compensating for line pressure	66

Chapter 6	Troubleshooting.....	69
	6.1 Section overview.....	69
	6.2 Safety messages.....	69
	6.3 Service support.....	69
	6.4 Diagnostics and recommended action.....	70
	6.5 Plantweb™ and NE107 diagnostics.....	73
	6.6 Alert messages and fail safe type selection.....	74
	6.7 Disassembly procedures.....	75
	6.8 Reassembly procedures.....	77
Appendix A	Reference data.....	81
	A.1 Product Certifications.....	81
	A.2 Ordering Information, Specifications, and Drawings.....	81
Appendix B	Local Operator Interface (LOI) Menu.....	83
	B.1 Overview.....	83
	B.2 Safety messages.....	83
	B.3 Detailed LOI Menu.....	84
Appendix C	PROFIBUS® Block Information.....	87
	C.1 Overview.....	87
	C.2 Safety messages.....	87
	C.3 PROFIBUS block parameters.....	87
	C.4 Condensed status.....	93

1 Introduction

1.1 Using this manual

The sections in this manual provide information on installing, operating, and maintaining the Rosemount 3051 Pressure Transmitter with PROFIBUS[®] PA Protocol. The sections are organized as follows:

- [Configuration](#) provides instruction on commissioning and operating Rosemount 3051 Transmitters. Information on software functions, configuration parameters, and online variables is also included.
- [Hardware Installation](#) contains mechanical installation instructions, and field upgrade options.
- [Electrical Installation](#) contains electrical installation instructions, and field upgrade options.
- [Calibration](#) contains operation and maintenance techniques.
- [Troubleshooting](#) provides troubleshooting techniques for the most common operating problems.
- [Specifications and Reference Data](#) supplies reference and specification data, as well as ordering information.
- [Product Certifications](#) contains intrinsic safety approval information, European ATEX directive information, and approval drawings.
- [Local Operator Interface \(LOI\) Menu](#) contains the complete local operator interface menu.
- [PROFIBUS[®] Block Information](#) contains PROFIBUS block and parameter information.

1.2 Models covered

Figure 1-1: Commissioning and Installation Flowchart

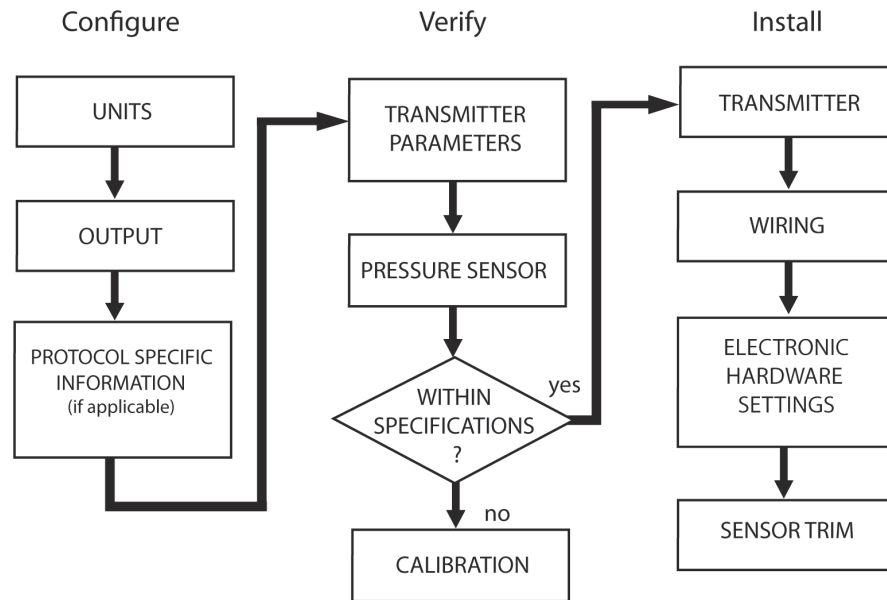

The following Rosemount 3051 Pressure Transmitters are covered by this manual:

- Rosemount 3051C Coplanar™ Pressure Transmitter
- Rosemount 3051CD Differential Pressure Transmitter
 - Measures differential pressure up to 2000 psi (137,9 bar)
- Rosemount 3051CG Gage Pressure Transmitter
 - Measures gage pressure up to 2000 psi (137,9 bar)
- Rosemount 3051CA Absolute Pressure Transmitter
 - Measures absolute pressure up to 4000 psia (275,8 bar)
- Rosemount 3051T In-Line Pressure Transmitter
- Rosemount 3051T Gage and Absolute Pressure Transmitter
 - Measures gage pressure up to 10000 psi (689,5 bar)
- Rosemount 3051L Liquid Level Transmitter
 - Provides precise level and specific gravity measurements up to 300 psi (20,7 bar) for a wide variety of tank configurations

Note

For Rosemount 3051 with HART® Protocol, see [Reference Manual](#). For Rosemount 3051 with FOUNDATION™ Fieldbus, see [Reference Manual](#).

1.3 Device revisions

Date	Software revision	PROFIBUS profile	Compatible files	Manual revision
10/16	2.6.1	3.02	3051 GSD: rmt4444.gsd Profile 3.02 GSD: pa139700.gsd DD: ROPA3_TP_3051.ddl DTM: Pressure_PROFIBUS_3.02_DTM_v1.0.8.exe	DB

1.4 Transmitter overview

The Rosemount 3051C Coplanar design is offered for differential pressure (DP), gage pressure (GP), and absolute pressure (AP) measurements. The Rosemount 3051C utilizes Emerson Process Management capacitance sensor technology for DP and GP measurements. Piezoresistive sensor technology is utilized in the Rosemount 3051T and 3051CA measurements.

The major components of the Rosemount 3051 are the sensor module and the electronics housing. The sensor module contains the oil filled sensor system (isolating diaphragms, oil fill system, and sensor) and the sensor electronics. The sensor electronics are installed within the sensor module and include a temperature sensor (RTD), a memory module, and the capacitance to digital signal converter (C/D converter). The electrical signals from the sensor module are transmitted to the output electronics in the electronics housing. The electronics housing contains the output electronics board, the optional local operator interface (LOI) buttons, and the terminal block.

For the Rosemount 3051C design pressure is applied to the isolating diaphragms, the oil deflects the center diaphragm, which then changes the capacitance. This capacitance signal is then changed to a digital signal in the C/D converter. The microprocessor then takes the signals from the RTD and C/D converter calculates the correct output of the transmitter.

1.5 Product recycling/disposal

Recycling of equipment and packaging should be taken into consideration and disposed of in accordance with local and national legislation/regulations.

2 Configuration

2.1 Section overview

This section contains information on commissioning the Rosemount™ 3051 Pressure Transmitter with PROFIBUS® PA Protocol using either the local operator interface (LOI) or Class 2 Master.

2.2 Safety messages

Procedures and instructions in this section may require special precautions to ensure the safety of the personnel performing the operations. Information that raises potential safety issues is indicated by a warning symbol (⚠). Refer to the following safety messages before performing an operation preceded by this symbol.

⚠ WARNING

Explosions could result in death or serious injury.

Installation of this transmitter in an explosive environment must be in accordance with the appropriate local, national, and international standards, codes, and practices. Review the approvals section of this Reference Manual for any restrictions associated with a safe installation.

In an explosion-proof/flameproof installation, do not remove the transmitter covers when power is applied to the unit.

Process leaks could result in death or serious injury.

Install and tighten process connectors before applying pressure.

Electrical shock could cause death or serious injury.

Avoid contact with the leads and terminals. High voltage that may be present on leads can cause electrical shock.

2.3 Hazardous locations certifications

Individual transmitters are clearly marked with a tag indicating the approvals they carry. Transmitters must be installed in accordance with all applicable codes and standards to maintain these certified ratings. Refer to [Product Certifications](#) for information on these approvals.

2.4 Configuration guidelines

The Rosemount 3051 can be configured either before or after installation. Configuring the transmitter on the bench using the LOI or Class 2 Master ensures that all transmitter components are in working order prior to installation.

To configure on the bench, required equipment includes a power supply, an LOI (option M4) or a Class 2 Master with DP/PA coupler, proper cable and terminators.

Verify the Security hardware jumper is set to the OFF position in order to proceed with configuration. See [Figure 4-2](#) for jumper location.

2.4.1 Profile 3.02 identification number adaptation mode

Rosemount 3051 PROFIBUS Profile 3.02 devices are set to Identification Number Adaptation mode (0127) when shipped from the factory. This mode allows the transmitter to communicate with any PROFIBUS Class 1 Master with either the generic Profile GSD (9700) or Rosemount 3051 specific GSD (4444).

2.4.2 Block modes

When configuring a device with the LOI, the output status will change to Good – Function Check to alert hosts that the transmitter is not in standard operation mode.

When configuring a device with a Class 2 Master, blocks must be set to Out of Service (OOS) to download parameters that could affect the output. This prevents the Class 1 Master from seeing a jump in output without a status change. Setting the blocks OOS and back into Auto might be done automatically using the Class 2 Master when using the Rosemount 3051 DD or DTM™, if no additional action is required when configuring the device. Verify the block mode is set back to Auto.

2.4.3 Configuration tools

The Rosemount 3051 can be configured using two tools: LOI and/or Class 2 Master.

The LOI requires option code M4 to be ordered. To activate the LOI, push either configuration button located under the top tag of the transmitter. See [Table 2-1](#) and [Figure 2-1](#) for operation and menu information. See [Local Operator Interface \(LOI\) Menu](#) for a complete LOI menu tree.

Class 2 Masters require either DD or DTM files for configuration. These files can be found at Emerson.com/Rosemount or by contacting Emerson representative. Some configurations steps may need to be completed in offline mode or using the LOI.

The remainder of this section covers the configuration tasks using the applicable configuration tool.

Note

Instructions in this section use the language found in the Class 2 Master or LOI. See to cross reference parameters between the Class 2 Master, LOI and PROFIBUS specification.

2.5 Basic setup tasks

The following tasks are recommended for initial configuration of the Rosemount 3051 PROFIBUS Device.

2.5.1 Assign address

The Rosemount 3051 is shipped with a temporary address of 126. This must be changed to a unique value between 0 and 125 in order to establish communication with the Class 1 Master. Usually, addresses 0–2 are reserved for masters, therefore transmitter addresses between 3 and 125 are recommended for the device.

Address can be set using either:

- LOI – see [Table 2-1](#) and [Figure 2-1](#)
- Class 2 Master – see respective Class 2 Master manual for setting instrument addresses

2.5.2 Pressure configuration

The Rosemount 3051 ships with the following settings:

- Measurement type: Pressure
- Engineering units: Inches H₂O
- Linearization: None
- Scaling: None

Each of these parameters can be set using,

- LOI – see [Table 2-1](#) and [Figure 2-1](#)
- Class 2 Master – see [Pressure configuration using Class 2 Master](#)



Pressure unit parameters

The LOI was designed to automatically set the following parameters when selecting a Pressure Unit:

- Measurement type: Pressure
- Linearization (Transducer Block): None
- Scaling: None

See Flow or Level Configuration for defaults when configuring with the LOI.

Table 2-1: LOI Operation

Button	Action	Navigation	Character entry	Save?
	Scroll	Moves down menu categories	Changes character value ⁽¹⁾	Changes between Save and Cancel
	Enter	Select menu category	Enters character and advances	Saves

⁽¹⁾ Characters flash when they can be changed.

Figure 2-1: LOI Menu

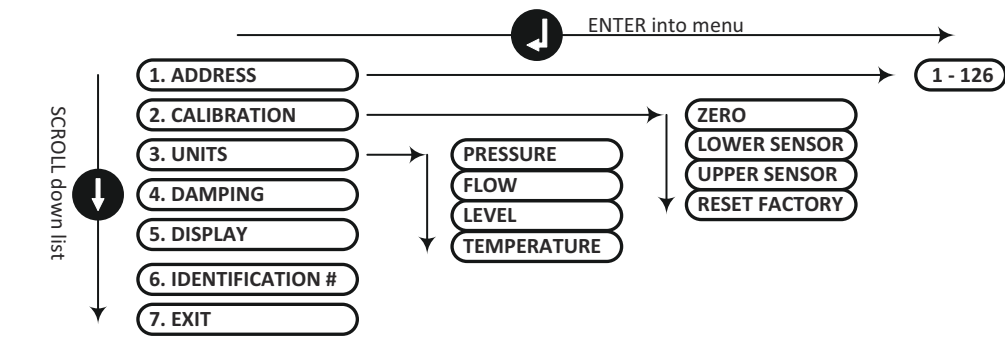

Note

See [Local Operator Interface \(LOI\) Menu](#) for a more detailed LOI menu and unit list.

Pressure configuration using Class 2 Master

Procedure

1. From the **Basic Setup** → **Units** → **Primary Value** → **Primary Value Type** dropdown, select **Pressure**.
2. Select units.

Note

Pressure units in steps [Step 3](#), [3.a](#), and [3.b](#) must match.

3. From the **Basic Setup** → **Units** → **Primary Value** → **Scale In (Transducer Block)** → **Unit (Secondary Value 1)** dropdown, select engineering unit.
 - a) From the **Basic Setup** → **Units** → **Primary Value** → **Unit (PV)** dropdown, select engineering unit.
 - b) From the **Basic Setup** → **Units** → **Output Signal (Analog Input Block)** → **Unit (Out Scale)** dropdown, select engineering unit.
4. Enter scaling.

Note

Scaling is done in the Transducer Block.

5. In the **Basic Setup** → **Units** → **Primary Value** → **Scale In (Transducer Block)** field, enter upper and lower values (this value should correspond to the unit selected in step [Step 3](#)).
 - a) In the **Basic Setup** → **Units** → **Primary Value** → **Scale Out (Transducer Block)** field, enter upper and lower values (this value should correspond to the unit selected in step [3.a](#)).
6. Verify Analog Input (AI) Block.

Note

Scaling should not be repeated in the AI Block. To ensure no additional scaling is being done on the AI Block, set the lower values in steps [Step 7](#) and [7.a](#) to 0 and the upper values to 100.

7. In the **Basic Setup** → **Units** → **Process Value Scale (Analog Input Block)** field, enter upper and lower values (this value should correspond to the unit selected in step [3.a](#)).
 - a) In the **Basic Setup** → **Units** → **Output Signal (Analog Input Block)** field, enter upper and lower values (this value should correspond to the unit selected in step [3.b](#)).
 - b) From the **Basic Setup** → **Units** → **Output Signal (Analog Input Block)** → **Linearization Type** dropdown, select **No Linearization**.

2.6 Detailed setup tasks

The following tasks explain how to configure the Rosemount 3051 for Flow or Level measurement and how to configure additional parameters found in the device.

2.6.1 LOI Flow configuration

To configure the Rosemount 3051 for Flow measurement with the LOI, select **UNITS** → **FLOW**. When configuring Flow units, the following parameters are set:

- Measurement type: Flow
- Linearization (Transducer Block): Square Root

During unit configuration, the user defines scaling, units and low flow cutoff per the application requirements. See [Local Operator Interface \(LOI\) Menu](#) for detailed menu for further scaling help.

Note

The LOI assumes a zero based scaling (minimum pressure = minimum flow = zero) for Flow applications in order to improve configuration efficiency. Class 2 Masters can be used if non-zero based scaling is required. Low flow cutoff has a default value of five percent. Low Flow cutoff can be set to zero percent if required.

2.6.2 Class 2 Master flow configuration

To configure the transmitter for a flow application, use the flow output in the Transducer Block.

Procedure

1. From the **Basic Setup** → **Units** → **Primary Value** → **Primary Value Type** dropdown, select **Flow**.
2. Select units.

Note

Flow units in steps 2.b and 2.c must match.

- a) From the **Basic Setup** → **Units** → **Primary Value** → **Scale In (Transducer Block)** → **Unit (Secondary Value 1)** dropdown, select engineering unit.
 - b) From the **Basic Setup** → **Units** → **Primary Value** → **Unit (PV)** dropdown, select engineering unit.
 - c) From the **Basic Setup** → **Units** → **Output Signal (Analog Input Block)** → **Unit (Out Scale)** dropdown, select engineering unit.
3. Enter scaling.

Note

Scaling is done in the Transducer Block.

- a) In the **Basic Setup** → **Units** → **Primary Value** → **Scale In (Transducer Block)** field, enter upper and lower values (this value should correspond to the unit selected in step 2.a).
 - b) In the **Basic Setup** → **Units** → **Primary Value** → **Scale Out (Transducer Block)** field, enter upper and lower values (this value should correspond to the unit selected in step 2.b).
4. Verify Analog Input (AI) Block.

Note

Scaling should always be done in the Transducer Block. Ensure the AI Block is always set to no linearization for flow applications. To ensure no additional scaling is being done on the AI Block, set the lower values in steps 4.a and 4.b to 0 and the upper values to 100.

- a) In the **Basic Setup** → **Units** → **Process Value Scale (Analog Input Block)** field, enter upper and lower values (this value should correspond to the unit selected in step 2.b).
- b) In the **Basic Setup** → **Units** → **Output Signal (Analog Input Block)** field, enter upper and lower values (this value should correspond to the unit selected in Step 2.c).
- c) From the **Basic Setup** → **Units** → **Output Signal (Analog Input Block)** → **Linearization Type** dropdown, select **No Linearization**.

2.6.3 Square root of DP configuration

The Rosemount 3051 has two pressure output settings: Linear and Square Root. Activate the square root output option to make output proportional to flow.

To configure the transmitter to output square root of differential pressure, a Class 2 Master must be used.

Square Root configuration using Class 2 Master

Procedure

1. From the **Basic Setup** → **Units** → **Primary Value** → **Primary Value Type** dropdown menu, select pressure.
2. Select Units.

Note

Pressure units in steps [2.a](#), [2.b](#), and [2.c](#) must match.

- a) From the **Basic Setup** → **Units** → **Primary Value** → **Scale In (Transducer Block)** → **Unit (Secondary Value 1)** dropdown, select engineering unit.
 - b) From the **Basic Setup** → **Units** → **Primary Value** → **Unit (PV)** dropdown, select engineering unit.
 - c) From the **Basic Setup** → **Units** → **Output Signal (Analog Input Block)** → **Unit (Out Scale)** dropdown, select engineering unit.
3. Enter scaling.

Note

Scaling is done in the Transducer Block. No scaling required for pressure measurement.

- a) In the **Basic Setup** → **Units** → **Primary Value** → **Scale In (Transducer Block)** field, enter upper and lower values (this value should correspond to the unit selected in step [2.a](#)).
 - b) In the **Basic Setup** → **Units** → **Primary Value** → **Scale Out (Transducer Block)** field, enter upper and lower values (this value should correspond to the unit selected in step [2.b](#)).
4. Verify Analog Input (AI) Block.

Note

Scaling should not be repeated in the Analog Input Block. To ensure no additional scaling is being done on the AI Block, set the lower values in steps 4a and 4b to 0 and the upper values to 100.

- a) In the **Basic Setup** → **Units** → **Process Value Scale (Analog Input Block)** field, enter upper and lower values (this value should correspond to the unit selected in step [2.b](#)).
- b) In the **Basic Setup** → **Units** → **Output Signal (Analog Input Block)** field, enter upper and lower values (this value should correspond to the unit selected in step [2.c](#)).
- c) From the **Basic Setup** → **Units** → **Output Signal (Analog Input Block)** → **Linearization Type** dropdown, select **Square Root**.

2.6.4 LOI Level configuration

To configure the Rosemount 3051 for Level measurement with the LOI, select **UNITS** → **LEVEL**. When configuring Level units, the following parameters are set:

- Measurement type: Level
- Linearization (Transducer Block): None

During unit configuration, the user defines scaling and units per the application requirements. See [Local Operator Interface \(LOI\) Menu](#) for detailed menu for further scaling help.

2.6.5 Level configuration using Class 2 Master

To configure the transmitter for a level application, use the level output in the Transducer Block.

Procedure

1. From the **Basic Setup** → **Units** → **Primary Value** → **Primary Value Type** dropdown, select **Level**.
2. Select units.

Note

Level units in steps [3.a](#), and [3.b](#) must match.

3. From the **Basic Setup** → **Units** → **Primary Value** → **Scale In (Transducer Block)** → **Unit (Secondary Value 1)** dropdown, select engineering unit.
 - a) From the **Basic Setup** → **Units** → **Primary Value** → **Unit (PV)** dropdown, select engineering unit.
 - b) From the **Basic Setup** → **Units** → **Output Signal (Analog Input Block)** → **Unit (Out Scale)** dropdown, select engineering unit.
4. Enter scaling.

Note

Scaling is done in the Transducer Block.

5. In the **Basic Setup** → **Units** → **Primary Value** → **Scale In (Transducer Block)** field, enter upper and lower values (this value should correspond to the unit selected in step [Step 3](#)).
 - a) In the **Basic Setup** → **Units** → **Primary Value** → **Scale Out (Transducer Block)** field, enter upper and lower values (this value should correspond to the unit selected in step [3.a](#)).
6. Verify Analog Input (AI) Block.

Note

Scaling should not be repeated in the AI Block. To ensure no additional scaling is being done on the AI Block, set the lower values in steps [Step 7](#) and [7.a](#) to 0 and the upper values to 100.

7. In the **Basic Setup** → **Units** → **Process Value Scale (Analog Input Block)** field, enter upper and lower values (this value should correspond to the unit selected in step [3.a](#)).

- a) In the **Basic Setup** → **Units** → **Output Signal (Analog Input Block)** field, enter upper and lower values (this value should correspond to the unit selected in step 3.b).
- b) From the **Basic Setup** → **Units** → **Output Signal (Analog Input Block)** → **Characterization Type** dropdown, select **No Linearization**.

2.6.6 Damping

User-selected damping will affect the transmitters ability to respond to changes in the applied process. The Rosemount 3051 has a default damping value of 0.0 seconds applied in the analog input (AI) block.

Damping can be set using,

- LOI – see [Table 2-1](#) and [Figure 2-1](#)
- Class 2 Master – see [Damping configuration using Class 2 Master](#)

Damping configuration using Class 2 Master

Procedure

- In the **Basic Setup** → **Damping** → **Filter Time Const** field, enter value (in seconds).

2.6.7 Process alerts

Process alerts activate an output alert status when the configured alert point is exceeded. A process alert will be transmitted continuously if the output set points are exceeded. The alert will reset once the value returns within range.

Process Alert parameters are defined as follows

- Upper alarm: Changes Output Status to Good – Critical Alarm – Hi Limit
- Upper warning: Changes Output Status to Good – Advisory Alarm – Hi Limit
- Lower warning: Changes Output Status to Good – Advisory Alarm – Lo Limit
- Lower alarm: Changes Output Status to Good – Critical Alarm – Lo Limit
- Alarm hysteresis: Amount the output value must pass back into range before alarm is cleared.

Example

Upper alarm = 100 psi. Alarm hysteresis = 0.5 percent. After activation at 100 psi, the alarm will clear once the output goes below $99.5 \text{ psi} = 100 - 0.5 \text{ psi}$.

Process alerts can be set using a Class 2 Master.

Process alert configuration using Class 2 Master

Procedure

Enter process alerts.

- a) In the **Basic Setup** → **Output** → **Output Limits** → **Upper Limit Alarm Limits** field, enter upper alarm value.
- b) In the **Basic Setup** → **Output** → **Output Limits** → **Upper Limit Warning Limits** field, enter upper warning value.
- c) In the **Basic Setup** → **Output** → **Output Limits** → **Lower Limit Alarm Limits** field, enter lower alarm value.
- d) In the **Basic Setup** → **Output** → **Output Limits** → **Lower Limit Warning Limits** field, enter lower warning value.
- e) In the **Basic Setup** → **Output** → **Output Limits** → **Limit Hysteresis** field, enter a percent of range value.

2.6.8 LCD display

The LCD display connects directly to the electronics board which maintains direct access to the signal terminals. A display cover is provided to accommodate the display.

The display always indicates the transmitter output (Pressure, Flow or Level) as well as abbreviated diagnostic status when applicable. Sensor temperature and pressure are optional variables that can be configured using LOI or Class 2 Master. When turned on, the display will alternate between the selected variables.

For LCD display configuration using,

- LOI – see [Table 2-1](#) and [Figure 2-1](#)
- Class 2 Master – see [LCD display configuration using Class 2 Master](#)

LCD display configuration using Class 2 Master

Procedure

- In **Basic Setup** → **Display Variables** → **Local Operator Interface (LOI)** → **Display Selection**, select the process variables to be shown on the local display.

2.6.9 Security

The Rosemount 3051 has a hierarchy of security features. The security jumper on the electronics board (or optional LCD display) provides the highest level of security. With the jumper in the ON position, all writes to the transmitter will be disabled (including writes from the LOI or a Class 2 Master).

See [Electrical Installation](#) for details on jumper configuration.

2.6.10 LOI security

To prevent unauthorized changes, either set the security jumper to ON and/or set an LOI password (Refer to [Configure security and simulation](#)). The LOI password requires a user to enter a non-zero four digit password at the transmitter in order to operate the LOI.

These parameters can be set using a Class 2 Master.

LOI security configuration using Class 2 Master

Procedure

1. To turn on the LOI password, enter value in the **Basic Setup** → **Display Variables** → **Local Operator Interface (LOI)** → **Password field**.
2. To turn off the LOI password, enter 0 in the **Basic Setup** → **Display Variables** → **Local Operator Interface (LOI)** → **Password field**.

Note

Security jumper must be in the off position for the LOI to operate. The password appears after the LOI is activated using the local configuration buttons.

2.6.11 Simulation

The Rosemount 3051 has a simulation jumper located on the electronics board (or optional LCD display) that must be set to the ON position in order to simulate.

With the AI Block simulation enabled, the actual measurement value has no impact on the OUT value or the status.

Simulation configuration using Class 2 Master

Procedure

1. Set the simulation jumper to on.
2. To enable simulation, select the following in **Basic Setup** → **Simulation**:
 - a) Select **Enabled**.
 - b) Enter Simulation Value.
 - c) Select **Simulation Status**.
 - d) Select **Transfer**.
3. To disable simulation, select the following in **Basic Setup** → **Simulation**:
 - a) Select **Disabled**.
 - b) Select **Transfer**.
4. Set the simulation jumper to off.

3 Hardware Installation

3.1 Section overview

The information in this section covers installation considerations for the Rosemount™ 3051 Pressure Transmitter with PROFIBUS® PA Protocol. A Quick Start Guide is shipped with every transmitter to describe pipe-fitting, wiring procedures and basic configuration for initial installation.

3.2 Safety messages

Procedures and instructions in this section may require special precautions to ensure the safety of the personnel performing the operations. Information that raises potential safety issues is indicated by a warning symbol (⚠). Refer to the following safety messages before performing an operation preceded by this symbol.

⚠ WARNING

Explosions could result in death or serious injury.

Installation of this transmitter in an explosive environment must be in accordance with the appropriate local, national, and international standards, codes, and practices. Review the approvals section of this Reference Manual for any restrictions associated with a safe installation.

In an explosion-proof/flameproof installation, do not remove the transmitter covers when power is applied to the unit.

Process leaks could result in death or serious injury.

Install and tighten process connectors before applying pressure.

Electrical shock could cause death or serious injury.

Avoid contact with the leads and terminals. High voltage that may be present on leads can cause electrical shock.

3.3 Considerations

Measurement accuracy depends upon proper installation of the transmitter and impulse piping. Mount the transmitter close to the process and use a minimum of piping to achieve best accuracy. Also, consider the need for easy access, personnel safety, practical field calibration, and a suitable transmitter environment. Install the transmitter to minimize vibration, shock, and temperature fluctuation.

Important

Install the enclosed pipe plug (found in the box) in unused conduit opening with a minimum of five threads engaged to comply with explosion-proof requirements. For tapered threads, install the plug wrench tight. For material compatibility considerations,

see Material Selection and Compatibility Consideration Technical Note on [Emerson.com/Rosemount](https://www.emerson.com/Rosemount).

3.3.1 Mechanical considerations

Steam service

For steam service or for applications with process temperatures greater than the limits of the transmitter, do not blow down impulse piping through the transmitter. Flush lines with the blocking valves closed and refill lines with water before resuming measurement.

Side mounted

When the transmitter is mounted on its side, position the coplanar flange to ensure proper venting or draining. Mount the flange as shown in [Mounting requirements](#), keeping drain/vent connections on the bottom for gas service and on the top for liquid service.

3.3.2 Environmental considerations

Best practice is to mount the transmitter in an environment that has minimal ambient temperature change. The transmitter electronics temperature operating limits are -40 to 185 °F (-40 to 85 °C). Mount the transmitter so that it is not susceptible to vibration and mechanical shock and does not have external contact with corrosive materials.

3.4 Installation procedures

3.4.1 Mount the transmitter

For dimensional drawing information, refer to [Dimensional drawings](#).

Process flange orientation

Mount the process flanges with sufficient clearance for process connections. For safety reasons, place the drain/vent valves so the process fluid is directed away from possible human contact when the vents are used. In addition, consider the need for a testing or calibration input.

Housing rotation

To improve field access to wiring or to better view the optional LCD display:

Procedure

1. Loosen the housing rotation set screw using a $\frac{5}{64}$ -in. hex wrench.
2. Turn the housing left or right maximum up to 180° from its original position.⁽¹⁾

(1) The Rosemount 3051C original position aligns with “H” side; Rosemount 3051T original position is the opposite side of bracket holes.

CAUTION

Over rotating can damage the transmitter.

3. Re-tighten the housing rotation set screw to no more than seven in-lb when desired location is reached.

Figure 3-1: Housing Rotation

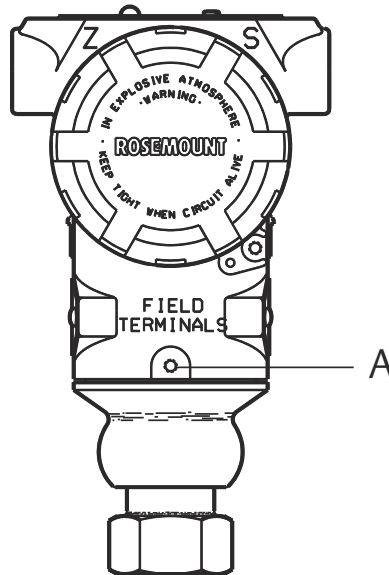

A. Housing rotation set screw ($5/64$ -in.)

Terminal side of electronics housing

Mount the transmitter so the terminal side is accessible. Clearance of 0.75-in. (19 mm) is required for cover removal. Use a conduit plug on the unused side of the conduit opening.

Circuit side of electronics housing

Provide 0.75-in. (19 mm) of clearance for units without an LCD display. Provide 3-in. (76 mm) of clearance for units installed with LCD display.

Conduit entry threads

For NEMA® 4X, IP66, and IP68 requirements, use thread seal (PTFE) tape or paste on male threads to provide a watertight seal.

Environmental seal for housing

Thread sealing (PTFE) tape or paste on male threads of conduit is required to provide a water/dust tight conduit seal and meets requirements of NEMA Type 4X, IP66, and IP68. Consult factory if other Ingress Protection ratings are required.

For M20 threads, install conduit plugs to full thread engagement or until mechanical resistance is met.

Always ensure a proper seal by installing electronics housing cover(s) so that metal contacts metal. Use Rosemount O-rings.

Mounting brackets

Rosemount 3051 may be panel-mounted or pipe-mounted through an optional mounting bracket. Refer to [Table 3-1](#) for the complete offering and see [Figure 3-2](#) through [Figure 3-6](#) for dimensions and mounting configurations.

Table 3-1: Mounting Brackets

Option code	Process connections			Mounting			Materials			
	Coplanar	In-line	Traditional	Pipe mount	Panel mount	Flat Panel mount	CS bracket	SST bracket	CS bolts	SST bolts
B4	X	X		X	X	X		X		X
B1			X	X			X		X	
B2			X		X		X		X	
B3			X			X	X		X	
B7			X	X			X			X
B8			X		X		X			X
B9			X			X	X			X
BA			X	X				X		X
BC			X			X		X		X

Figure 3-2: Mounting Bracket Option Code B4

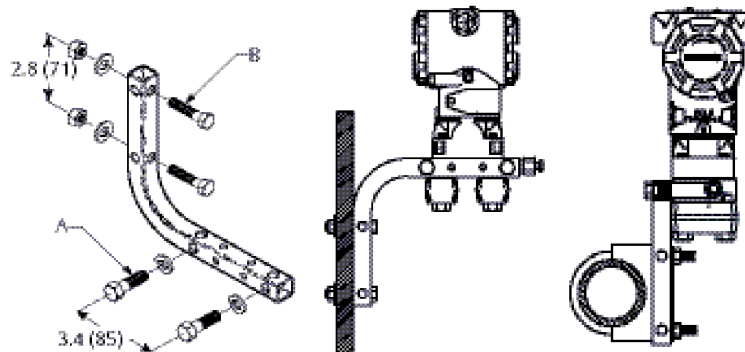

- A. $\frac{3}{8}$ -16 X 1¼-in. bolts for mounting to transmitter
- B. $\frac{5}{16}$ X 1½-in. bolts for panel mounting (not supplied)

Dimensions are in inches (millimeters).

Figure 3-3: Mounting Bracket Option Codes B1, B7, and BA

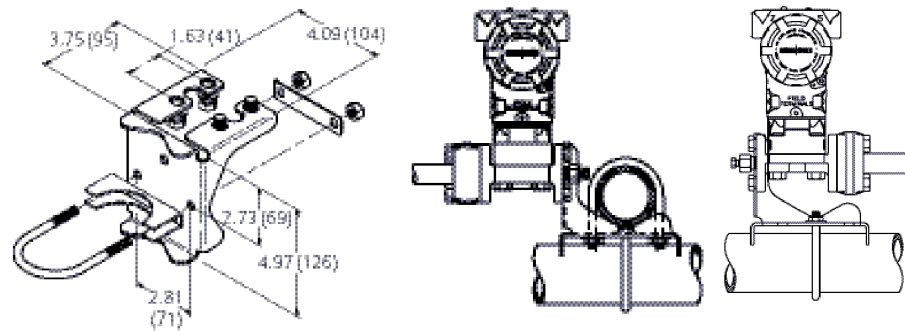

Dimensions are in inches (millimeters).

Figure 3-4: Panel Mounting Bracket Option Codes B2 and B8

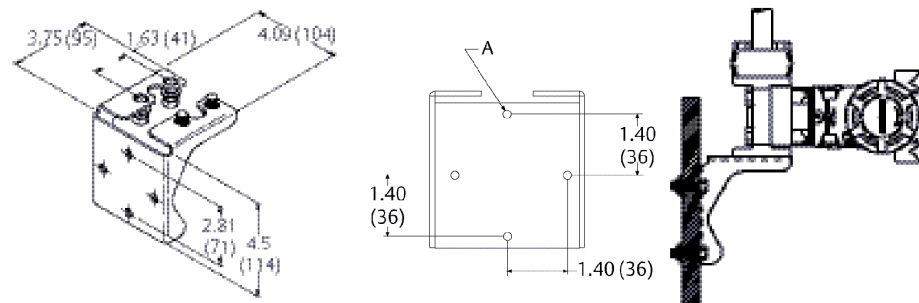

- A. Mounting holes 0.375 diameter (10)

Dimensions are in inches (millimeters).

Figure 3-5: Flat Mounting Bracket Option Codes B3 and BC

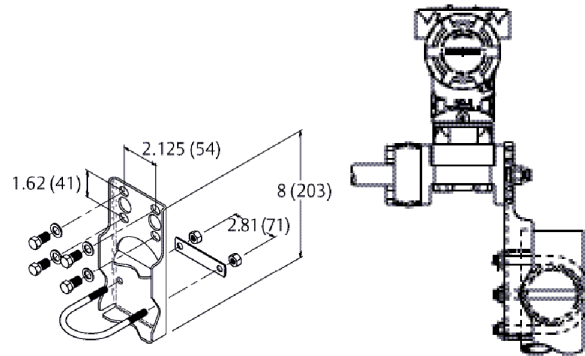

Dimensions are in inches (millimeters).

Flange bolts

Emerson can ship the Rosemount 3051 with a coplanar flange or a traditional flange installed with four 1.75-in. flange bolts. Mounting bolts and bolting configurations for the coplanar and traditional flanges can be found in [Bolt installation](#). Stainless steel bolts supplied by Emerson are coated with a lubricant to ease installation. Carbon steel bolts do not require lubrication. Do not apply additional lubricant when installing either type of bolt. Bolts supplied by Emerson are identified by their head markings.

Figure 3-6: Head Markings

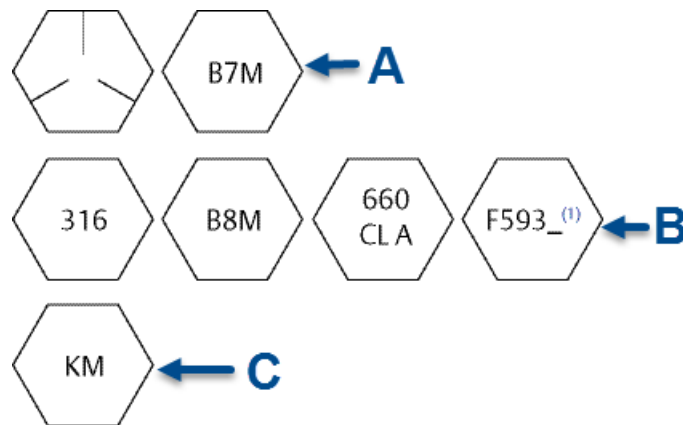

- A. Carbon steel (CS) head markings
- B. Stainless steel (SST) head markings
- C. Alloy K-500 head marking

Note

The last digit in the F593_ head marking may be any letter between A and M.

Bolt installation

Bolt installation procedure.

Only use bolts supplied with the Rosemount 3051 or sold by Emerson as spare parts for the Rosemount 3051 Transmitter.

Note

Carbon steel bolts do not require lubrication and the stainless steel bolts are coated with a lubricant to ease installation. However, no additional lubricant should be applied when installing either type of bolt.

Procedure

1. Finger-tighten the bolts.
2. Torque the bolts to the initial torque value using a crossing pattern (see [Table 3-2](#) for torque values).
3. Torque the bolts to the final torque value using the same crossing pattern.

Table 3-2: Bolt Installation Torque Values

Bolt material	Initial torque value	Final torque value
CS-ASTM-A445 Standard	300 in-lb (34 N-m)	650 in-lb (73 N-m)
316 SST—Option L4	150 in-lb (17 N-m)	300 in-lb (34 N-m)
ASTM-A-193-B7M—Option L5	300 in-lb (34 N-m)	650 in-lb (73 N-m)
Alloy 400—Option L6	300 in-lb (34 N-m)	650 in-lb (73 N-m)

Figure 3-7: Traditional Flange Bolt Configurations

Differential transmitter

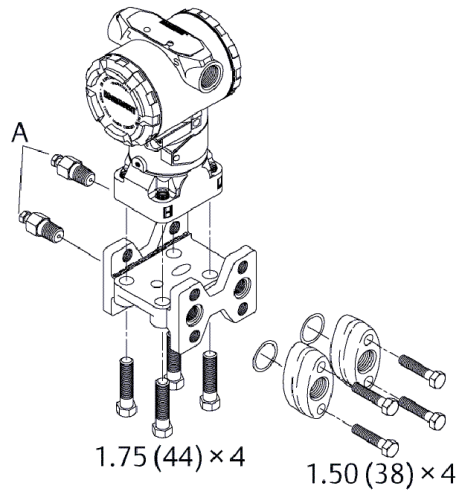

Gage/Absolute transmitter

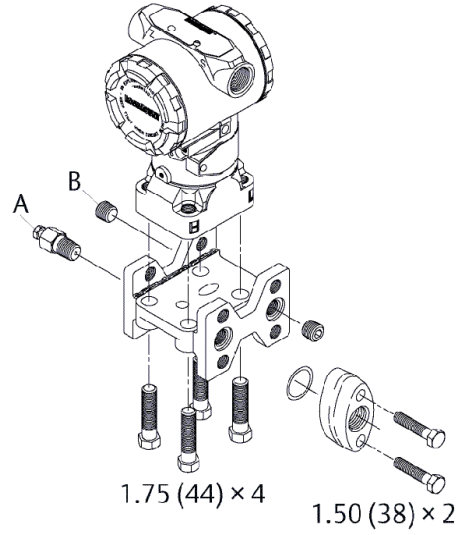

- A. Drain/vent
- B. Plug

Dimensions are in inches (millimeters).

Figure 3-8: Mounting Bolts and Bolt Configurations for Coplanar Flange

Transmitter with flange bolts

Transmitter with flange adapters and flange/adaptor bolts

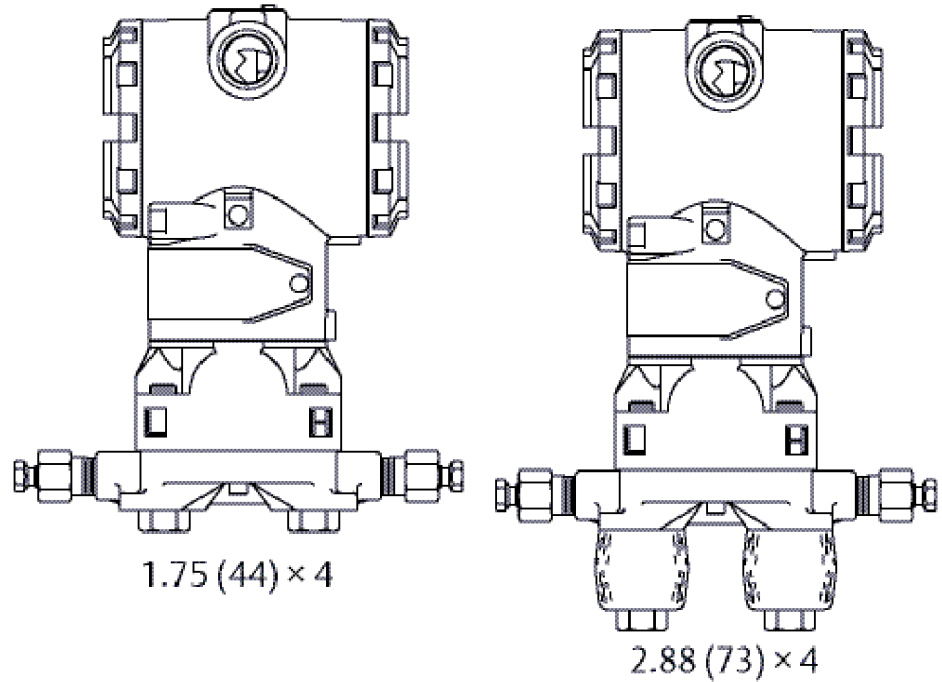

Dimensions are in inches (millimeters).

Description	Qty	Size (in. [mm])
Differential pressure		
Flange bolts	4	1.75 (44)
Flange/adaptor bolts	4	2.88 (73)
Gage/absolute pressure⁽¹⁾		
Flange bolts	4	1.75 (44)
Flange/adaptor bolts	2	2.88 (73)

(1) Rosemount 3051T Transmitters are direct mount and do not require bolts for process connection.

3.4.2 Impulse piping

Mounting requirements

Impulse piping configurations depend on specific measurement conditions. Refer to [Figure 3-9](#) for examples of the following mounting configurations:

Liquid flow measurement

- Place taps to the side of the line to prevent sediment deposits on the transmitter's process isolators
- Mount the transmitter beside or below the taps so gases can vent into the process line
- Mount drain/vent valve upward to allow gases to vent

Gas flow measurement

- Place taps in the top or side of the line
- Mount the transmitter beside or above the taps so liquid will drain into the process line

Steam flow measurement

- Place taps to the side of the line
- Mount the transmitter below the taps to ensure that the impulse piping will stay filled with condensate
- In steam service above 250 °F (121 °C), fill impulse lines with water to prevent steam from contacting the transmitter directly and to ensure accurate measurement start-up

Note

For steam or other elevated temperature services, it is important that temperatures at the process connection do not exceed the transmitter's process temperature limits.

Figure 3-9: Installation Examples

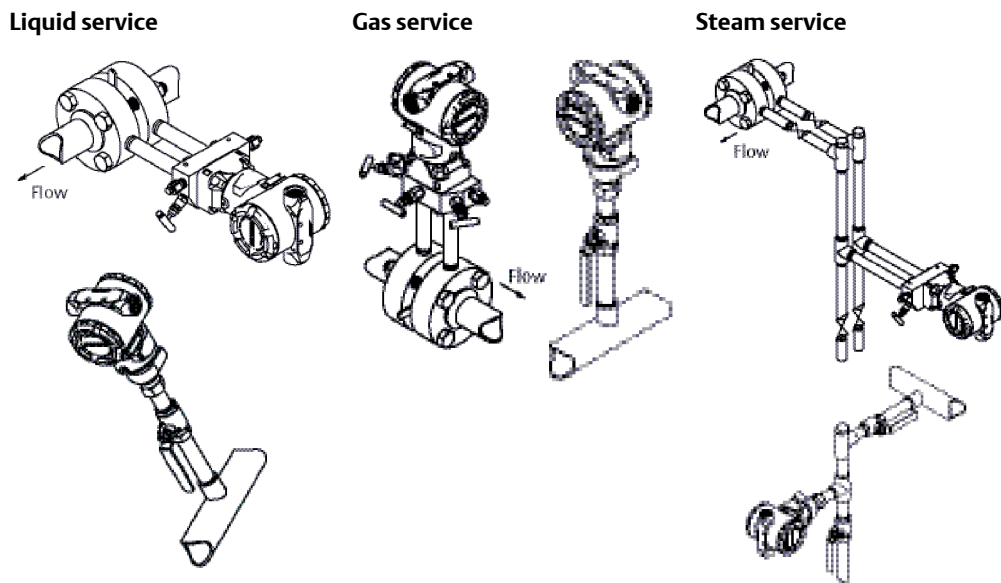

Best practices

The piping between the process and the transmitter must accurately transfer the pressure to obtain accurate measurements. There are five possible sources of error: pressure transfer, leaks, friction loss (particularly if purging is used), trapped gas in a liquid line, liquid in a gas line, and density variations between the legs.

The best location for the transmitter in relation to the process pipe is dependent on the process. Use the following guidelines to determine transmitter location and placement of impulse piping:

- Keep impulse piping as short as possible.
- For liquid service, slope the impulse piping at least 1-in./ft. (8 cm/m) upward from the transmitter toward the process connection.
- For gas service, slope the impulse piping at least 1-in./ft. (8 cm/m) downward from the transmitter toward the process connection.
- Avoid high points in liquid lines and low points in gas lines.
- Make sure both impulse legs are the same temperature.
- Use impulse piping large enough to avoid friction effects and blockage.
- Vent all gas from liquid piping legs.
- When using a sealing fluid, fill both piping legs to the same level.
- When purging, make the purge connection close to the process taps and purge through equal lengths of the same size pipe. Avoid purging through the transmitter.

- Keep corrosive or hot (above 250 °F [121 °C]) process material out of direct contact with the sensor module and flanges.
- Prevent sediment deposits in the impulse piping.
- Maintain equal leg of head pressure on both legs of the impulse piping.
- Avoid conditions that might allow process fluid to freeze within the process flange.

3.4.3 Process connections

Coplanar or traditional process connections

Install and tighten all four flange bolts before applying pressure, or process leakage will result. When properly installed, the flange bolts will protrude through the top of the sensor module housing. Do not attempt to loosen or remove the flange bolts while the transmitter is in service.

Flange adapters

Rosemount 3051DP and GP process connections on the transmitter flanges are ¼ – 18 NPT. Flange adapters are available with standard ½ – 14 NPT Class 2 connections. The flange adapters allow users to disconnect from the process by removing the flange adapter bolts. Use plant-approved lubricant or sealant when making the process connections. Refer to [Dimensional drawings](#) for the distance between pressure connections. This distance may be varied $\pm \frac{1}{8}$ -in. (3.2 mm) by rotating one or both of the flange adapters.

To install adapters to a coplanar flange, perform the following procedure:

Procedure

1. Remove the flange bolts.
2. Leaving the flange in place, move the adapters into position with the O-ring installed.
3. Clamp the adapters and the coplanar flange to the transmitter sensor module using the larger of the bolts supplied.
4. Tighten the bolts. Refer to [Flange bolts](#) for torque specifications.

Example

Whenever removing flanges or adapters, visually inspect the PTFE O-rings. Replace with O-ring designed for Rosemount transmitter if there are any signs of damage, such as nicks or cuts. Undamaged O-rings may be reused. If you replace the O-rings, retorque the flange bolts after installation to compensate for cold flow. Refer to the process sensor body reassembly procedure in [Troubleshooting](#).

When compressed, PTFE O-rings tend to “cold flow,” which aids in their sealing capabilities.

Note

PTFE O-rings should be replaced if the flange adapter is removed.

O-rings

The two styles of Rosemount flange adapters (Rosemount 1151 and 3051/2051/2024/3095) each require a unique O-ring. Use only the O-ring designed for the corresponding flange adapter.

⚠ WARNING

Failure to install proper flange adapter O-rings may cause process leaks, which can result in death or serious injury. The two flange adapters are distinguished by unique O-ring grooves. Only use the O-ring that is designed for its specific flange adapter, as shown below:

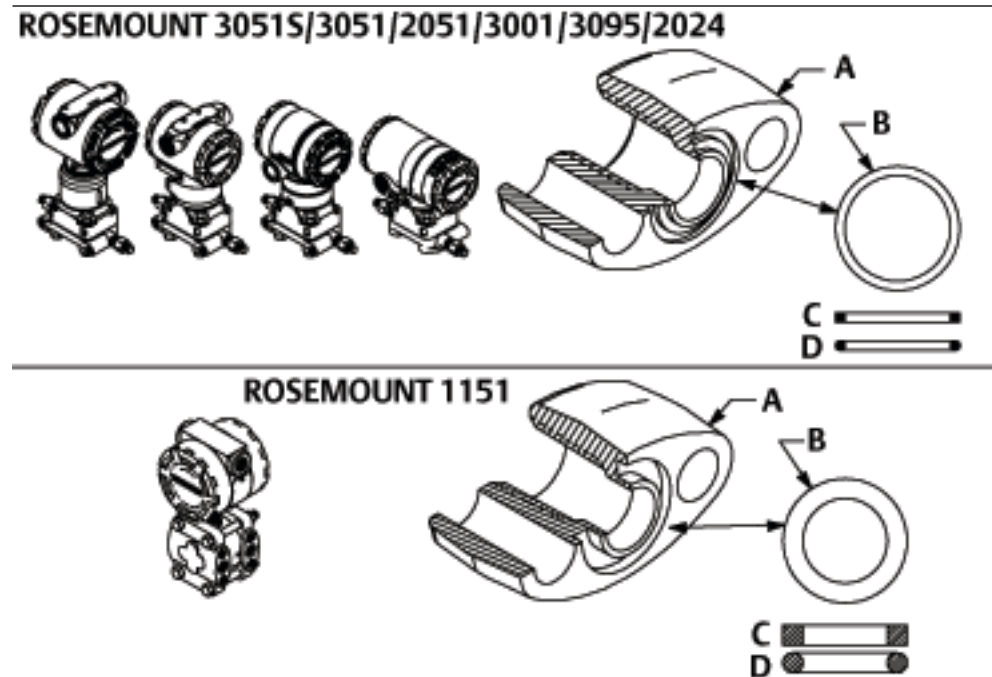

- A. Flange adapter
- B. O-ring
- C. PTFE based
- D. Elastomer

When compressed, PTFE O-rings tend to *cold flow*, which aids in their sealing capabilities.

Note

Replace PTFE O-rings if the flange adapter is removed.

3.4.4 Inline process connection

Inline gage transmitter orientation

⚠ CAUTION

Erroneous pressure values

The transmitter may output erroneous pressure values.

Do not interfere or block the atmospheric reference port.

The low side pressure port on the inline gage transmitter is located in the neck of the transmitter, behind the housing. The vent path is 360 degrees around the transmitter between the housing and sensor (see [Figure 3-10](#)).

Keep the vent path free of any obstruction, such as paint, dust, and lubrication, by mounting the transmitter so that the process can drain away.

Figure 3-10: Inline Gage Low Side Pressure Port

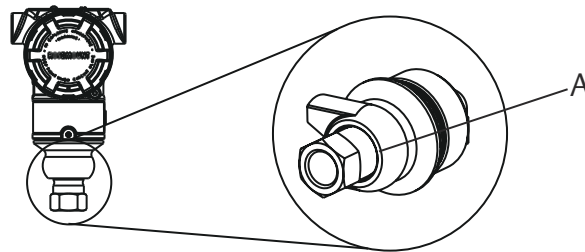

A. Low side pressure port (atmospheric reference)

⚠ CAUTION

Electronics damage

Rotation between the sensor module and the process connection can damage the electronics.

Do not apply torque directly to the sensor module.

To avoid damage, apply torque only to the hex-shaped process connection.

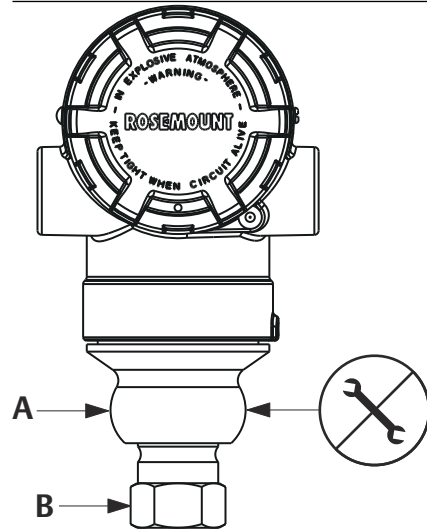

- A. Sensor module
- B. Process connection

3.5 Rosemount 305, 306, and 304 manifolds

The Rosemount 305 integral manifold mounts directly to the transmitter and is available in two styles: traditional and coplanar. The traditional Rosemount 305 integral manifold can be mounted to most primary elements with mounting adapters in the market today. The Rosemount 306 integral manifold is used with the Rosemount 3051T In-Line Transmitters to provide block-and-bleed valve capabilities of up to 10000 psi (690 bar).

Figure 3-11: Manifolds

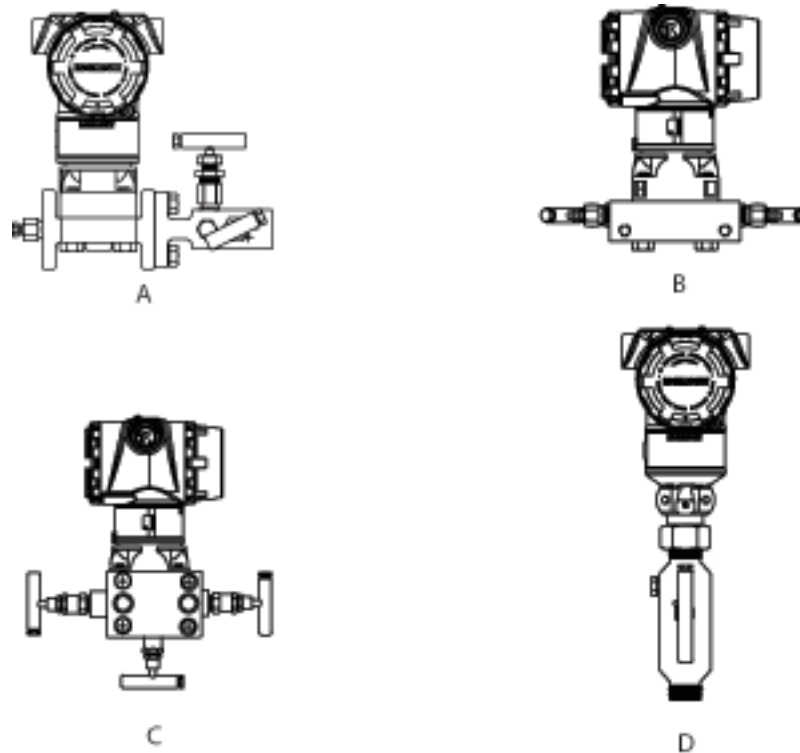

- A. Rosemount 3051C and 304 conventional
- B. Rosemount 3051C and 305 integral coplanar
- C. Rosemount 3051C and 305 integral traditional
- D. Rosemount 3051T and 306 in-line

The Rosemount 304 conventional manifold combines a traditional flange and manifold that can be mounted to most primary elements.

3.5.1 Install Rosemount 305 Integral Manifold

Procedure

1. Inspect the PTFE sensor module O-rings.
You may reuse undamaged O-rings. If the O-rings are damaged (if they have nicks or cuts, for example), replace with O-rings designed for Rosemount transmitters.

Important

If replacing the O-rings, take care not to scratch or deface the O-ring grooves or the surface of the isolating diaphragm while you remove the damaged O-rings.

2. Install the Integral Manifold on the sensor module. Use the four 2.25-in. (57.2 mm) manifold bolts for alignment. Finger tighten the bolts; then tighten the bolts incrementally in a cross pattern as seen in [Figure 3-12](#) to final torque value.

See [Flange bolts](#) for complete bolt installation information and torque values. When fully tightened, the bolts should extend through the top of the sensor module housing.

Figure 3-12: Bolt Tightening Pattern

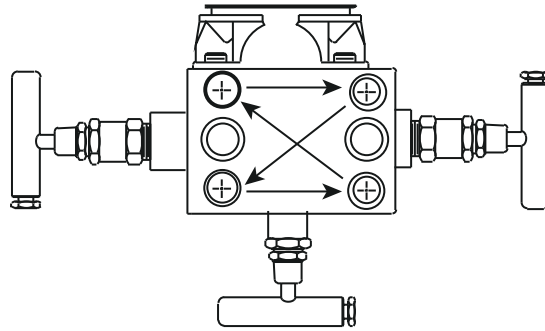

3. If you have replaced the PTFE sensor module O-rings, re-tighten the flange bolts after installation to compensate for cold flow of the O-rings.

3.5.2 Install Rosemount 306 integral manifold

The Rosemount 306 Manifold is for use only with in-line pressure transmitters such as the Rosemount 3051T and 2051T.

Assemble the Rosemount 306 manifold to the Rosemount 3051T or 2051T In-Line Transmitters with a thread sealant.

3.5.3 Install Rosemount 304 Conventional Manifold

See [Safety messages](#) for complete warning information.

Procedure

1. Align the Conventional Manifold with the transmitter flange. Use the four manifold bolts for alignment.
2. Finger tighten the bolts; then tighten the bolts incrementally in a cross pattern to final torque value.
See [Flange bolts](#) for complete bolt installation information and torque values. When fully tightened, the bolts should extend through the top of the sensor module housing.
3. Leak-check assembly to maximum pressure range of transmitter.

3.5.4 Manifold operation

⚠ WARNING

Improper installation or operation of manifolds may result in process leaks, which may cause death or serious injury.

Always perform a zero trim on the transmitter/manifold assembly after installation to eliminate any shift due to mounting effects. See [Sensor trim overview](#).

Coplanar transmitters Operate three and five-valve manifolds

Performing zero trim at static line pressure

In normal operation, the two isolate (block) valves between the process ports and the transmitter will be open, and the equalize valve will be closed.

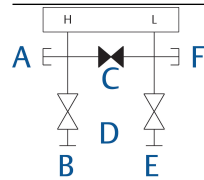

- A. Drain/vent valve
- B. Isolate (open)
- C. Equalize (closed)
- D. Process
- E. Isolate (open)
- F. Drain/vent valve

Procedure

1. To zero trim the transmitter, close the isolate valve on the low side (downstream) side of the transmitter.

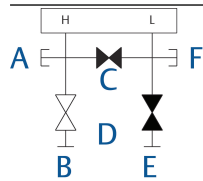

- A. Drain/vent valve
- B. Isolate (open)
- C. Equalize (closed)
- D. Process
- E. Isolate (closed)
- F. Drain/vent valve

2. Open the equalize valve to equalize the pressure on both sides of the transmitter. The manifold is now in the proper configuration for performing a zero trim on the transmitter.

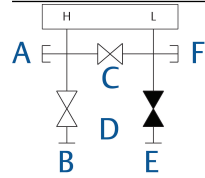

- A. Drain/vent valve
 - B. Isolate (open)
 - C. Equalize (open)
 - D. Process
 - E. Isolate (closed)
 - F. Drain/vent valve
-

3. After zeroing the transmitter, close the equalize valve.

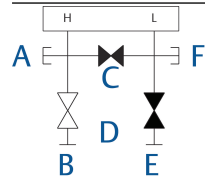

- A. Drain/vent valve
 - B. Isolate (open)
 - C. Equalize (closed)
 - D. Process
 - E. Isolate (closed)
 - F. Drain/vent valve
-

4. Finally, to return the transmitter to service, open the low side isolate valve.

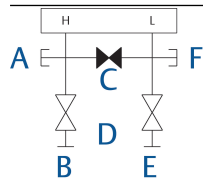

- A. Drain/vent valve
- B. Isolate (open)
- C. Equalize (closed)
- D. Process
- E. Isolate (open)
- F. Drain/vent valve

Operate five-valve natural gas manifold

Performing zero trim at static line pressure

Five-valve natural gas configurations shown:

In normal operation, the two isolate (block) valves between the process ports and the transmitter will be open, and the equalize valves will be closed. Vent valves may be open or closed.

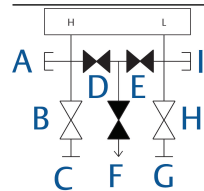

- A. (Plugged)
- B. Isolate (open)
- C. Process
- D. Equalize (closed)
- E. Equalize (closed)
- F. Drain vent (closed)
- G. Process
- H. Isolate (open)
- I. (Plugged)

Procedure

1. To zero trim the transmitter, first close the isolate valve on the low pressure (downstream) side of the transmitter and the vent valve.

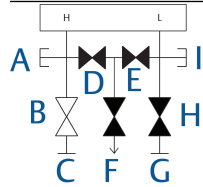

- A. (Plugged)
 - B. Isolate (open)
 - C. Process
 - D. Equalize (closed)
 - E. Equalize (closed)
 - F. Drain vent (closed)
 - G. Process
 - H. Isolate (closed)
 - I. (Plugged)
-

2. Open the equalize valve on the high pressure (upstream) side of the transmitter.

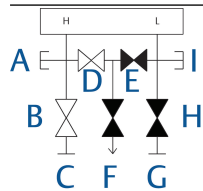

- A. (Plugged)
 - B. Isolate (open)
 - C. Process
 - D. Equalize (open)
 - E. Equalize (closed)
 - F. Drain vent (closed)
 - G. Process
 - H. Isolate (closed)
 - I. (Plugged)
-

3. Open the equalize valve on the low pressure (downstream) side of the transmitter.
The manifold is now in the proper configuration for zeroing the transmitter.

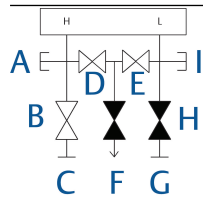

- A. *(Plugged)*
 - B. *Isolate (open)*
 - C. *Process*
 - D. *Equalize (open)*
 - E. *Equalize (open)*
 - F. *Drain vent (closed)*
 - G. *Process*
 - H. *Isolate (closed)*
 - I. *(Plugged)*
-

4. After zeroing the transmitter, close the equalize valve on the low pressure (downstream) side of the transmitter.
-

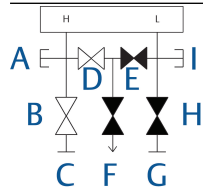

- A. *(Plugged)*
 - B. *Isolate (open)*
 - C. *Process*
 - D. *Equalize (open)*
 - E. *Equalize (closed)*
 - F. *Drain vent (closed)*
 - G. *Process*
 - H. *Isolate (closed)*
 - I. *(Plugged)*
-

5. Close the equalize valve on the high pressure (upstream) side.

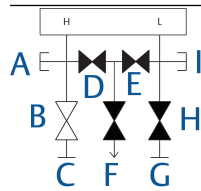

- A. (Plugged)
- B. Isolate (open)
- C. Process
- D. Equalize (closed)
- E. Equalize (closed)
- F. Drain vent (closed)
- G. Process
- H. Isolate (closed)
- I. (Plugged)

6. Finally, to return the transmitter to service, open the low side isolate valve and vent valve.

The vent valve can remain open or closed during operation.

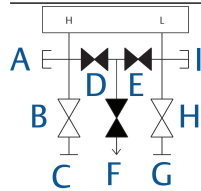

- A. (Plugged)
- B. Isolate (open)
- C. Process
- D. Equalize (closed)
- E. Equalize (closed)
- F. Drain vent (closed)
- G. Process
- H. Isolate (open)
- I. (Plugged)

In-line transmitters 2-valve and block and bleed style manifolds

Isolating the transmitter

In normal operation, the isolate (block) valve between the process port and transmitter will be open and the test/vent valve will be closed. On a block and bleed style manifold, a single block valve provides transmitter isolation, and a bleed screw provides drain/vent capabilities.

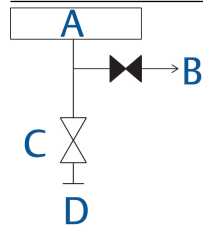

- A. Transmitter
- B. Vent (closed)
- C. Isolate
- D. Process (open)

Procedure

1. To isolate the transmitter, close the isolate valve.

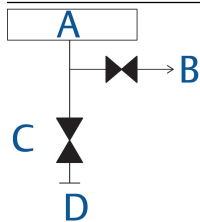

- A. Transmitter
- B. Vent (closed)
- C. Isolate
- D. Process (closed)

2. To bring the transmitter to atmospheric pressure, open the vent valve or bleed screw.

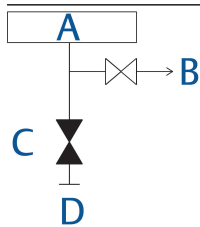

- A. Transmitter
- B. Vent (open)
- C. Isolate
- D. Process (closed)

Note

A 1/4-in (6.35 mm). male NPT pipe plug may be installed in the test/vent port; you will need to remove it with a wrench in order to vent the manifold properly. Always use caution when venting directly to atmosphere.

3. After venting to atmosphere, perform any required calibration and then close the test/vent valve or replace the bleed screw.

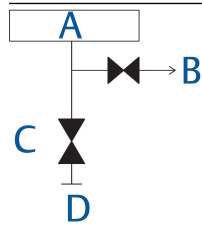

- A. Transmitter
 - B. Vent (closed)
 - C. Isolate
 - D. Process (closed)
-

4. Open the isolate (block) valve to return the transmitter to service.

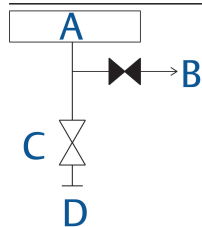

- A. Transmitter
 - B. Vent (closed)
 - C. Isolate
 - D. Process (open)
-

Adjust valve packing

Over time, the packing material inside a Rosemount manifold may require adjustment in order to continue to provide proper pressure retention. Not all Rosemount manifolds have this adjustment capability. The Rosemount manifold model number will indicate what type of stem seal or packing material has been used.

The following steps are provided as a procedure to adjust valve packing:

Procedure

1. Remove all pressure from device.
2. Loosen manifold valve jam nut.
3. Tighten manifold valve packing adjuster nut $\frac{1}{4}$ turn.
4. Tighten manifold valve jam nut.
5. Re-apply pressure and check for leaks.

Postrequisites

Repeat the above steps if necessary. If the above procedure does not result in proper pressure retention, replace the complete manifold.

Figure 3-13: Valve Components

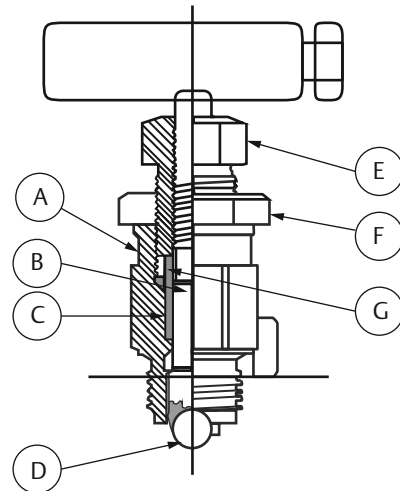

- A. Bonnet
- B. Stem
- C. Packing
- D. Ball/tip
- E. Packing adjuster
- F. Jam nut
- G. Packing follower

3.6 Liquid level measurement

Differential pressure transmitters used for liquid level applications measure hydrostatic pressure head. Liquid level and specific gravity of a liquid are factors in determining pressure head. This pressure is equal to the liquid height above the tap multiplied by the specific gravity of the liquid. Pressure head is independent of volume or vessel shape.

3.6.1 Open vessels

A pressure transmitter mounted near a tank bottom measures the pressure of the liquid above.

Make a connection to the high pressure side of the transmitter and vent the low pressure side to the atmosphere. Pressure head equals the liquid's specific gravity multiplied by the liquid height above the tap.

Zero range suppression is required if the transmitter lies below the zero point of the desired level range. [Figure 3-14](#) shows a liquid level measurement example.

3.6.2 Closed vessels

Pressure above a liquid affects the pressure measured at the bottom of a closed vessel. The liquid specific gravity multiplied by the liquid height plus the vessel pressure equals the pressure at the bottom of the vessel.

To measure true level, the vessel pressure must be subtracted from the vessel bottom pressure. To do this, make a pressure tap at the top of the vessel and connect this to the low side of the transmitter. Vessel pressure is then equally applied to both the high and low sides of the transmitter. The resulting differential pressure is proportional to liquid height multiplied by the liquid specific gravity.

Dry leg condition

Low-side transmitter piping will remain empty if gas above the liquid does not condense. This is a dry leg condition. Range determination calculations are the same as those described for bottom-mounted transmitters in open vessels, as shown in [Figure 3-14](#).

Figure 3-14: Liquid Level Measurement Example

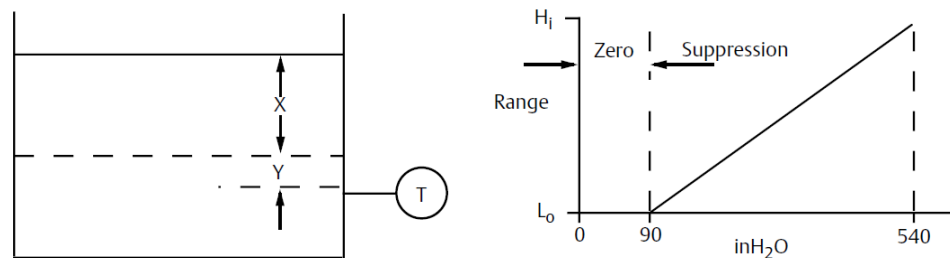

Let X equal the vertical distance between the minimum and maximum measurable levels (500 in. [12700 mm]).

Let Y equal the vertical distance between the transmitter datum line and the minimum measurable level (100 in. [2540 mm]).

Let SG equal the specific gravity of the fluid (0.9).

Let h equal the maximum head pressure to be measured in inches of water.

Let e equal head pressure produced by Y expressed in inches of water.

Let Range equal e to e + h.

Then $h = (X)(SG)$

$= 500 \times 0.9$

$= 450 \text{ inH}_2\text{O}$

$e = (Y)(SG)$

$= 100 \times 0.9$

$= 90 \text{ inH}_2\text{O}$

Range = 90 to 540 inH₂O

Wet leg condition

Condensation of the gas above the liquid slowly causes the low side of the transmitter piping to fill with liquid. The pipe is purposely filled with a convenient reference fluid to eliminate this potential error. This is a wet leg condition.

The reference fluid will exert a head pressure on the low side of the transmitter. You must then make zero elevation of the range.

Figure 3-15: Wet Leg Example

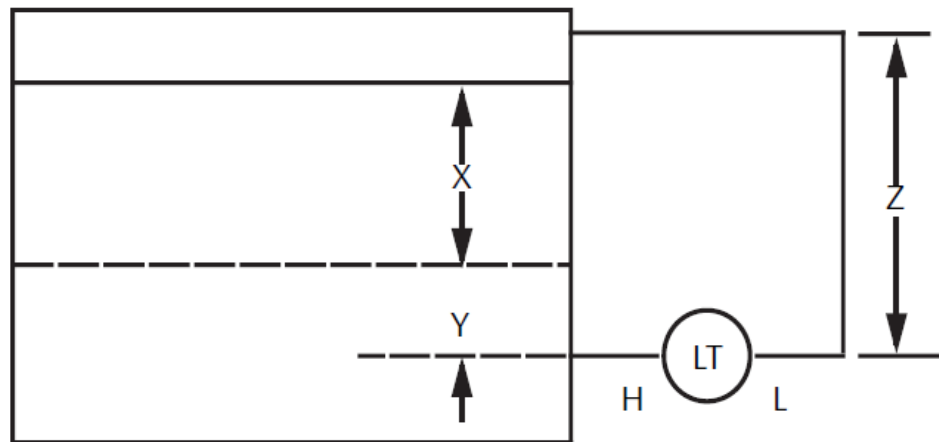

Let X equal the vertical distance between the minimum and maximum measurable levels (500 in. [12700 mm]).

Let Y equal the vertical distance between the transmitter datum line and the minimum measurable level (50 in. [1270 mm]).

Let z equal the vertical distance between the top of the liquid in the wet leg and the transmitter datum line (600 in. [15240 mm]).

Let SG1 equal the specific gravity of the fluid (1.0).

Let SG2 equal the specific gravity of the fluid in the wet leg (1.1).

Let h equal the maximum head pressure to be measured in inches of water.

Let e equal the head pressure produced by Y expressed in inches of water.

Let s equal head pressure produced by z expressed in inches of water.

Let Range equal $e - s$ to $h + e - s$.

Then $h = (X)(SG1)$

$= 500 \times 1.0$

$= 500 \text{ in H}_2\text{O}$

$e = (Y)(SG1)$

$= 50 \times 1.0$

$= 50 \text{ in H}_2\text{O}$

$$\begin{aligned}
 s &= (z)(SG2) \\
 &= 600 \times 1.1 \\
 &= 660 \text{ in H}_2\text{O} \\
 \text{Range} &= e - s \text{ to } h + e - s \\
 &= 50 - 660 \text{ to } 500 + 50 - 660 \\
 &= -610 \text{ to } -110 \text{ in H}_2\text{O}
 \end{aligned}$$

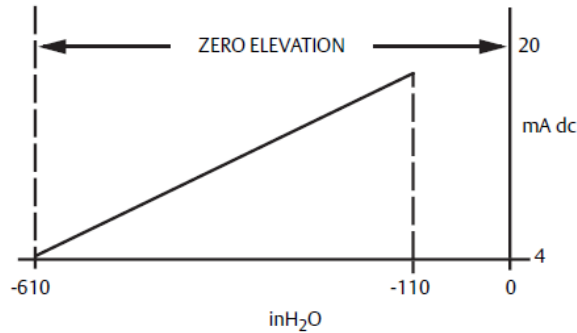

Bubbler system in open vessel

A bubbler system that has a top-mounted pressure transmitter can be used in open vessels. This system consists of an air supply, pressure regulator, constant flow meter, pressure transmitter, and a tube that extends down into the vessel.

Bubble air through the tube at a constant flow rate. The pressure required to maintain flow equals the liquid's specific gravity multiplied by the vertical height of the liquid above the tube opening. [Figure 3-16](#) shows a bubbler liquid level measurement example.

Figure 3-16: Bubbler Liquid Level Measurement Example

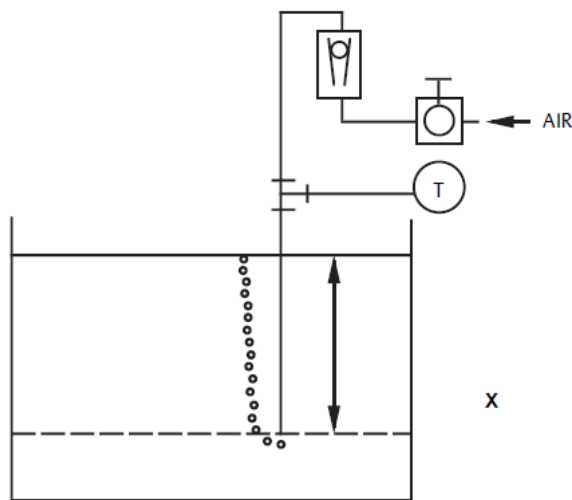

Let X equal the vertical distance between the minimum and maximum measurable levels (100 in. [2540 mm]).

Let SG equal the specific gravity of the fluid (1.1).

Let h equal the maximum head pressure to be measured in inches of water.

Let Range equal zero to h.

Then $h = (X)(SG)$

$= 100 \times 1.1$

$= 110 \text{ inH}_2\text{O}$

Range = 0 to 110 inH₂O

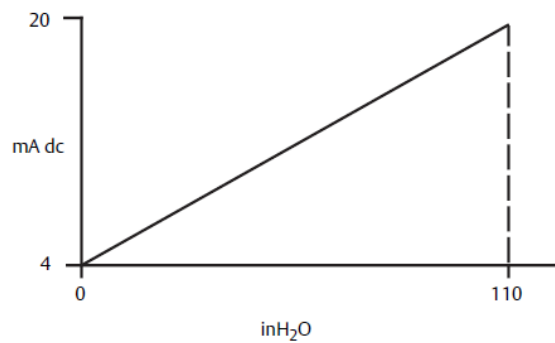

4 Electrical Installation

4.1 Section overview

The information in this section covers installation considerations for the Rosemount™ 3051 Pressure Transmitter with PROFIBUS® PA Protocol. A Quick Start Guide is shipped with every transmitter to describe pipe-fitting, wiring procedures and basic configuration for initial installation.

4.2 Safety messages

Procedures and instructions in this section may require special precautions to ensure the safety of the personnel performing the operations. Information that raises potential safety issues is indicated by a warning symbol (⚠). Refer to the following safety messages before performing an operation preceded by this symbol.

⚠ WARNING

Explosions could result in death or serious injury.

Installation of this transmitter in an explosive environment must be in accordance with the appropriate local, national, and international standards, codes, and practices. Review the approvals section of this Reference Manual for any restrictions associated with a safe installation.

In an explosion-proof/flameproof installation, do not remove the transmitter covers when power is applied to the unit.

Process leaks could result in death or serious injury.

Install and tighten process connectors before applying pressure.

Electrical shock could cause death or serious injury.

Avoid contact with the leads and terminals. High voltage that may be present on leads can cause electrical shock.

4.3 LCD display

Transmitters ordered with the LCD display option (M5) are shipped with the display installed. Installing the display on an existing Rosemount 3051 requires a small instrument screwdriver.

Figure 4-1: LCD Display

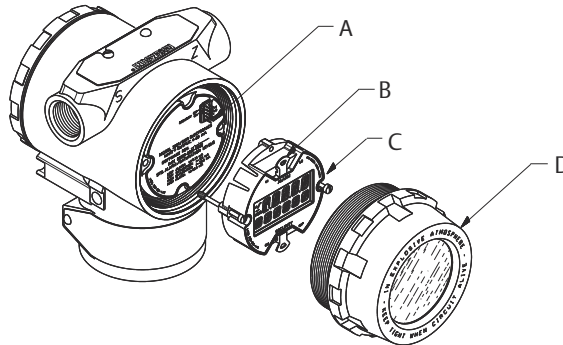

- A. Interconnecting pins
- B. Jumpers (top and bottom)
- C. LCD display
- D. Extended cover

4.4 LCD display with local operator interface (LOI)

Transmitters ordered with the LCD display with LOI option (M4) are shipped with the display and local configuration buttons installed. The configuration buttons are located under the top tag as indicated by the sticker. See [Table 2-1](#) for LOI operation. Upgrading to an LOI transmitter requires installation of a new electronics board, configuration buttons and LCD display (if not previously ordered).

4.5 Configure security and simulation

4.5.1 Security (write protect)

There are four security methods with the Rosemount 3051 Transmitter:

Procedure

1. Security jumper: prevents all writes to transmitter configuration, including use of the LOI.
2. Software Write Protection: prevents all writes to the transmitter configuration using a Class 2 Master.
3. Disable Local Operator Interface: prevents changes to transmitter range points using local configuration buttons.
4. LOI password: Requires a four-digit password before changes can be made locally.

Example

You can prevent changes to the transmitter configuration data with the write protection jumper. Security is controlled by the security (write protect) jumper located on the electronics board or LCD display. Position the jumper on the transmitter circuit board in the ON position to prevent accidental or deliberate change of configuration data.

If the transmitter write protection jumper is in the ON position, the transmitter will not accept any “writes” to its memory.

Note

If the security jumper is not installed, the transmitter will continue to operate in the security OFF configuration.

4.5.2 Simulate

The Rosemount 3051 has a simulate jumper located on the electronics board (or optional LCD display) that must be set to the ON position in order to activate simulate mode using a Class 2 Master.

See [Configuration](#) for details on Simulate mode.

Figure 4-2: Transmitter Jumper Locations

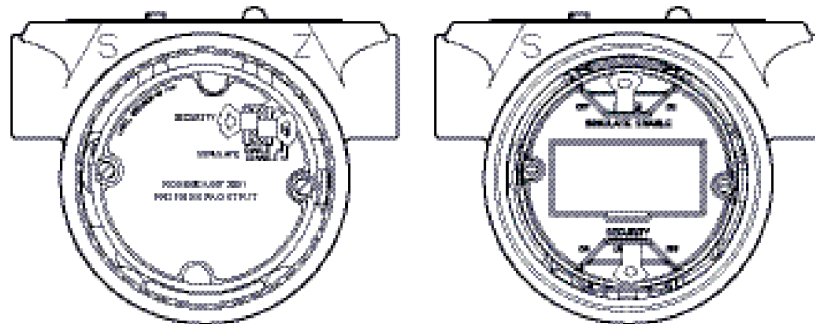

4.6 Electrical considerations

Make sure all electrical installation is in accordance with national and local code requirements.

4.6.1 Conduit installation

Recommended conduit connections are shown in [Figure 4-3](#).

⚠ CAUTION

If all connections are not sealed, excess moisture accumulation can damage the transmitter. Make sure to mount the transmitter with the electrical housing positioned downward for drainage. To avoid moisture accumulation in the housing, install wiring with a drip loop, and ensure the bottom of the drip loop is mounted lower than the conduit connections or the transmitter housing.

Figure 4-3: Conduit Installation

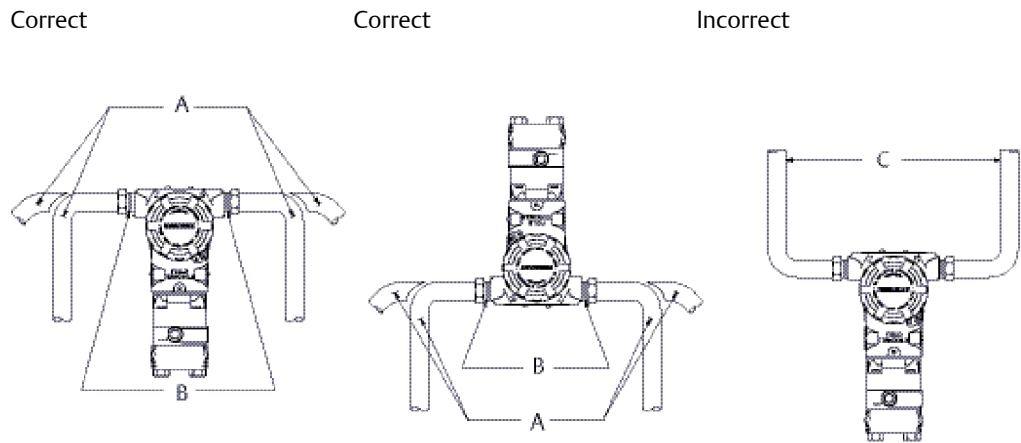

- A. Possible conduit line positions
- B. Sealing compound
- C. Conduit lines

4.6.2

Wiring

See [Figure 4-5](#) for a basic PROFIBUS PA system configuration.

Use the following steps to wire the transmitter:

Procedure

1. Remove the housing cover on the FIELD TERMINALS side.
2. Connect the power leads to the terminals indicated on the terminal block label (See [Figure 4-4](#)).
3. Power terminals are polarity insensitive - connect positive or negative to either terminal
4. Tighten the terminal screws to ensure full contact with the terminal block screw and washer. When using a direct wiring method, wrap wire clockwise to ensure it is in place when tightening the terminal block screw.

Note

The use of a pin or ferrule wire terminal is not recommended as the connection may be more susceptible to loosening over time or under vibration.

5. Ensure proper grounding (See [Figure 4-6](#)). It is important the instrument cable shield:
 - be trimmed close and insulated from touching the transmitter housing
 - be connected to the next shield if cable is routed through a junction box
 - be connected to a good earth ground at the power supply end
6. Plug and seal unused conduit connections.
7. If applicable, install wiring with a drip loop. See [Figure 4-3](#).

8. Replace the housing cover.

Figure 4-4: Rosemount 3051 PROFIBUS Terminal Block

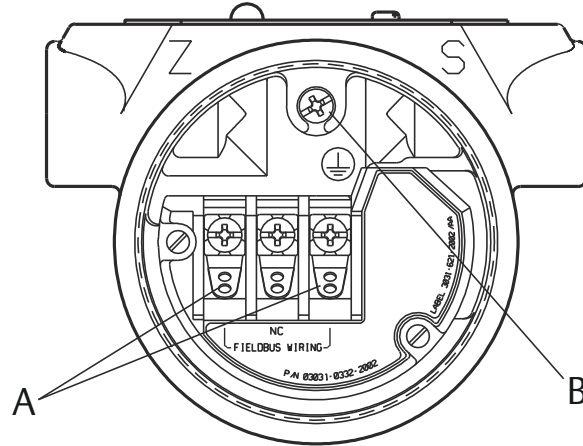

- A. Power terminals
- B. Ground terminal

Note

“NC” is a No Connect terminal (do not use).

Figure 4-5: Basic PROFIBUS PA System Configuration

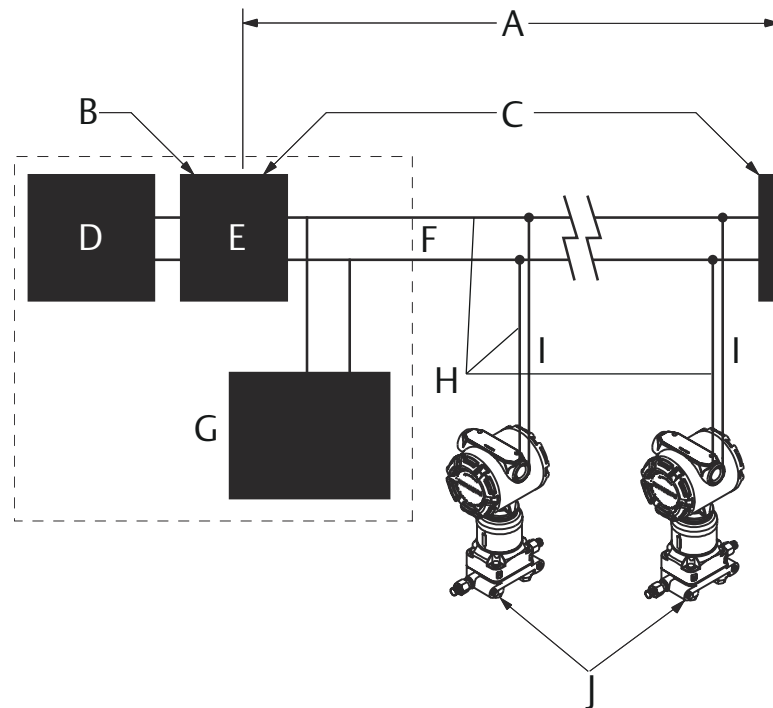

- A. 6234 ft (1900 m) max (depending upon cable characteristics)
- B. Integrated power conditioner and filter
- C. Terminators
- D. Power supply
- E. DP/PA coupler/link
- F. Trunk
- G. DP network
- H. Signal wiring
- I. Spur
- J. PROFIBUS PA device

4.6.3 Signal wiring grounding

Do not run signal wiring in conduit or open trays with power wiring, or near heavy electrical equipment. Grounding terminations are provided on the outside of the electronics housing and inside the terminal compartment. These grounds are used when transient protect terminal blocks are installed or to fulfill local regulations. See [Step 2](#) for more information on how the cable shield should be grounded.

Procedure

1. Remove the field terminals housing cover.
2. Connect the wiring pair and ground as indicated in [Figure 4-6](#).
 - Be trimmed close and insulated from touching the transmitter housing

- Continuously connect to the termination point
- Be connected to a good earth ground at the power supply end

Figure 4-6: Wiring

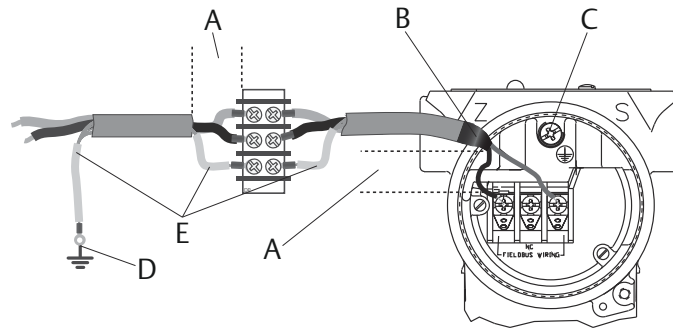

- A. Minimize distance*
- B. Trim shield and insulate*
- C. Ground for transient protection*
- D. Shield connected to power supply ground*
- E. Insulate shield*

3. Replace the housing cover.
It is recommended the cover be tightened until there is no gap between the cover and the housing.
4. Plug and seal unused conduit connections.

Power supply

The dc power supply should provide power with less than two percent ripple. The transmitter requires between 9 and 32 Vdc (between 9 and 17.5 Vdc for FISCO) at the terminals to operate and provide complete functionality.

Power conditioner

The DP/PA Coupler/Link often includes an integrated power conditioner.

Grounding

Transmitters are electrically isolated to 500 Vac rms. Signal wiring can not be grounded.

Shield wire ground

Grounding techniques for shield wire usually require a single grounding point for shield wire to avoid creating a ground loop. The ground point is typically at the power supply.

4.6.4 Transient protection terminal block

The transmitter will withstand electrical transients of the energy level usually encountered in static discharges or induced switching transients. However, high-energy transients, such as those induced in wiring from nearby lightning strikes, can damage the transmitter.

The transient protection terminal block can be ordered as an installed option (Option Code T1 in the transmitter model number) or as a spare part to retrofit existing Rosemount 3051 Transmitters in the field. See [Other spare parts](#) for spare part numbers. The lightning bolt symbol shown in [Figure 4-7](#) identifies the transient protection terminal block.

Figure 4-7: Wiring with Transient Protection

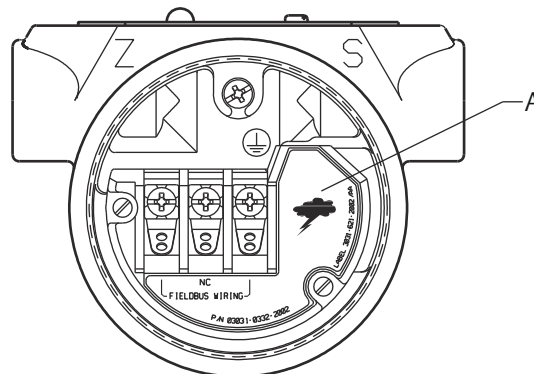

A. Transient protection symbol

Note

The transient protection terminal block does not provide transient protection unless the transmitter case is properly grounded. Use the guidelines to ground the transmitter case. Refer to [Grounding](#). Do not run the transient protection ground wire with signal wiring as the ground wire may carry excessive current if a lightning strike occurs.

4.6.5 Grounding

Transmitters are electrically isolated to 500 Vac rms. Signal wiring can not be grounded.

Signal wiring

Do not run signal wiring in conduit or open trays with power wiring or near heavy electrical equipment. It is important the instrument cable shield:

- be trimmed close and insulated from touching the transmitter housing
- be connected to the next shield if cable is routed through a junction box
- be connected to a good earth ground at the power supply end

Transmitter case

Always ground the transmitter case in accordance with national and local electrical codes. The most effective transmitter case grounding method is a direct connection to earth ground with minimal impedance. Methods for grounding the transmitter case include:

- Internal ground connection: The internal ground connection screw is inside the field terminals side of the electronics housing. This screw is identified by a ground symbol (⊖). The ground connection screw is standard on all Rosemount 3051 Transmitters. Refer to [Figure 4-4](#).
- External ground assembly: This assembly is included with the optional transient protection terminal block (option code T1), and it is included with various hazardous location certifications. The external ground assembly can also be ordered with the transmitter (option code V5), or as a spare part. See [Other spare parts](#). Refer to [Figure 4-8](#) for location of the external ground screw.

Figure 4-8: External Ground Assembly

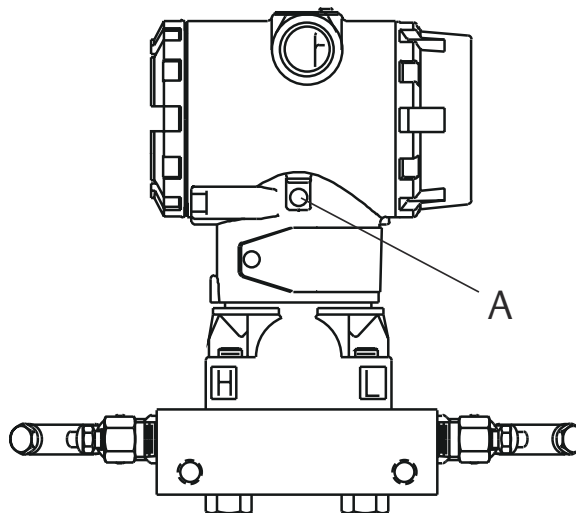

A. External ground assembly

Note

Grounding the transmitter case using threaded conduit connection may not provide sufficient ground continuity.

5 Calibration

5.1 Section overview

This section contains information on calibrating the Rosemount™ 3051 Pressure Transmitter with PROFIBUS® PA Protocol using either the local operator interface (LOI) or a Class 2 Master.

5.2 Safety messages

Procedures and instructions in this section may require special precautions to ensure the safety of the personnel performing the operations. Information that raises potential safety issues is indicated by a warning symbol (⚠). Refer to the following safety messages before performing an operation preceded by this symbol.

⚠ WARNING

Explosions could result in death or serious injury.

Installation of this transmitter in an explosive environment must be in accordance with the appropriate local, national, and international standards, codes, and practices. Review the approvals section of this Reference Manual for any restrictions associated with a safe installation.

In an explosion-proof/flameproof installation, do not remove the transmitter covers when power is applied to the unit.

Process leaks could result in death or serious injury.

Install and tighten process connectors before applying pressure.

Electrical shock could cause death or serious injury.

Avoid contact with the leads and terminals. High voltage that may be present on leads can cause electrical shock.

5.3 Calibration overview

Calibration optimizes transmitter accuracy over a specific range by adjusting the factory sensor characterization curve located in the microprocessor. This is done by performing one of the following procedures.

5.3.1 Zero trim

A single-point offset adjustment. It is useful for compensating for mounting position effects and is most effective when performed with the transmitter installed in its final mounting position.

When performing a zero trim with a manifold, refer to [Manifold operation](#).

Note

Do not perform a zero trim on absolute pressure transmitters. Zero trim is zero based, and absolute pressure transmitters reference absolute zero. To correct mounting position effects on absolute pressure transmitters, perform a lower trim within the sensor trim function. The lower trim function provides an offset correction similar to the zero trim function, but it does not require zero-based input.

5.3.2 Sensor trim

A two-point sensor calibration where two end-point pressures are applied, and all output is linearized between them. Always adjust the lower trim value first to establish the correct offset. Adjustment of the upper trim value provides a slope correction to the characterization curve based on the lower trim value. The trim values allow you to optimize performance over your specified measuring range at the calibration temperature. Sensor trimming requires an accurate pressure input – at least four times more accurate than the transmitter – in order to optimize performance over a specific pressure range.

Note

The Rosemount 3051 has been carefully calibrated at the factory. Trimming adjusts the position of the factory characterization curve. It is possible to degrade performance of the transmitter if any trim is done improperly or with inaccurate equipment.

Note

Rosemount 3051C Range 4 and Range 5 Transmitters require a special calibration procedure when used in differential pressure applications under high static line pressure. See [Compensating for line pressure](#).

5.3.3 Recall factory trim

A command that allows the restoration of the as-shipped factory settings of the sensor trim. This command can be useful for recovering from an inadvertent zero trim of an absolute pressure unit or inaccurate pressure source.

5.4 Determining calibration frequency

Calibration frequency can vary greatly depending on the application, performance requirements, and process conditions. Use the following procedure to determine calibration frequency that meets the needs of your application:

1. Determine the performance required for your application.
2. Determine the operating conditions.
3. Calculate the total probable error (TPE).
4. Calculate the stability per month.
5. Calculate the calibration frequency.

5.4.1 Sample calculation for a standard Rosemount 3051C

Procedure

1. Determine the performance required for your application.
 - Required performance: 0.20 percent of span
2. Determine the operating conditions.
 - Transmitter: Rosemount 3051CD, Range 2 (URL=250 inH₂O [623 mbar])
 - Calibrated span: 150 inH₂O (374 mbar)
 - Ambient temperature change: ±50 °F (28 °C)
 - Line pressure: 500 psig (34,5 bar)
3. Calculate total probable error (TPE).
 - $TPE = \sqrt{(\text{ReferenceAccuracy})^2 + (\text{TemperatureEffect})^2 + (\text{StaticPressureEffect})^2} = 0.117$ percent of span
 - Where:
 - Reference accuracy = ± 0.065 percent of span
 - Ambient temperature effect =
 $\pm \left(\frac{0.0125 \times \text{URL}}{\text{Span}} + 0.0625 \right) \% \text{ per } 50 \text{ } ^\circ\text{F} = \pm 0.0833\% \text{ of span}$
 - Span static pressure effect⁽²⁾ =
0.1% reading per 1000 psi (69 bar) = ±0.05% of span at maximum span
4. Calculate the stability per month.
5. Calculate calibration frequency.

5.5 Zero trim

Note

The transmitter PV at zero pressure must be within 10 percent x Upper Sensor Limit (USL) of zero in order to calibrate using the zero trim function.

5.5.1 Perform a zero trim using LOI

Procedure

Enter **Calibration** → **Zero** menu.

- a) Verify measurement is within 10 percent × LSL of zero.
- b) Save.

⁽²⁾ Zero static pressure effect removed by zero trimming at line pressure.

5.5.2 Perform a zero trim using Class 2 Master

Procedure

1. To set the Transducer Block to Out of Service, select the following:
 - a) From the **Basic Setup** → **Mode** → **Transducer Block** → **Target** dropdown, select **Out of Service**.
 - b) Select **Transfer**.
2. To calibrate the sensor, select the following in **Basic Setup** → **Calibration**:
 - a) In the Lower Calibration Point field, enter **0**.
 - b) Adjust pressure source to zero pressure.
 - c) Verify Pressure Trimmed Value is stable and within $10\% \times \text{LSL}$ of zero.
 - d) Select **Transfer**.
3. To set Transducer Block to Auto, select the following:
 - a) From the **Basic Setup** → **Mode** → **Transducer Block** → **Target** dropdown, select **Auto**.
 - b) Select **Transfer**.

5.6 Sensor trim

Note

Use a pressure input source that is at least four times more accurate than the transmitter, and allow the input pressure to stabilize for ten seconds before entering any values.

5.6.1 Sensor Trim using LOI

Procedure

1. Enter **Calibration** → **Lower menu**.
 - a) Enter trim unit and value.
 - b) Verify measurement is stable.
 - c) Save.
2. Enter **Calibration** → **Upper menu**.
 - a) Enter trim unit and value.
 - b) Verify measurement is stable.
 - c) Save.

5.6.2 Sensor trim using Class 2 Master

Procedure

1. To set the Transducer Block to Out of Service, select the following:
 - a) From the **Basic Setup** → **Mode** → **Transducer Block** → **Target Mode** dropdown, select **Out of Service**.
 - b) Select **Transfer**.
2. Set the lower sensor calibration, select the following in **Basic Setup** → **Calibration**:
 - a) In the Lower Calibration Point field, enter value.
 - b) Adjust pressure source to desired pressure.
 - c) Verify Pressure Trimmed Value is stable.
 - d) Select **Transfer**.
3. Set the upper sensor calibration, select the following in **Basic Setup** → **Calibration**:
 - a) In the Upper Calibration Point field, enter value.
 - b) Adjust pressure source to desired pressure.
 - c) Verify Pressure Trimmed Value is stable.
 - d) Select **Transfer**.
4. To set Transducer Block to Auto, select the following:
 - a) From the **Basic Setup** → **Mode** → **Transducer Block** → **Target Mode** dropdown, select **Auto**.
 - b) Select **Transfer**.

5.7 Recall factory trim

5.7.1 Recall factory trim using LOI

Procedure

Enter **Calibration** → **Reset** menu then save.

5.7.2 Recall factory trim using Class 2 Master

Procedure

1. To set the Transducer Block to Out of Service, select the following:
 - a) From the **Basic Setup** → **Mode** → **Transducer Block** → **Target** dropdown, select **Out of Service**.
 - b) Select **Transfer**.

2. To Recall the Factory Trim select the following in **Basic Setup** → **Calibration** → **Factory Recall**:
 - a) Select **Factory Settings**.
 - b) Select **Transfer**.
3. To set Transducer Block to AUTO, select the following:
 - a) From the **Basic Setup** → **Mode** → **Transducer Block** → **Target** dropdown, select **Auto**.
 - b) Select **Transfer**.

5.8 Compensating for line pressure

5.8.1 Range 2 and 3

The following specifications show the static pressure effect for the Rosemount 3051 Range 2 and 3 Pressure Transmitters used in differential pressure applications where line pressure exceeds 2000 psi (138 bar).

Zero effect

±0.1 percent of the upper range limit plus an additional ±0.1 percent of upper range limit error for each 1000 psi (69 bar) of line pressure above 2000 psi (138 bar).

Example

Line pressure is 3000 psi (207 bar) for Ultra performance transmitter.

Zero effect error calculation: $\pm(0.05 + 0.1 \times [3 \text{ kpsi} - 2 \text{ kpsi}]) = \pm 0.15$ percent of the upper range limit

Span effect

Refer to [Line pressure effect per 1000 psi \(68,95 bar\)](#).

5.8.2 Range 4 and Range 5

Rosemount 3051 Range 4 and 5 Pressure Transmitters require a special calibration procedure when used in differential pressure applications. The purpose of this procedure is to optimize transmitter performance by reducing the effect of static line pressure in these applications. The Rosemount 3051 Differential Pressure Transmitters (Ranges 1, 2, and 3) do not require this procedure because optimization occurs in the sensor.

Applying high static pressure to Rosemount 3051 Range 4 and 5 Pressure Transmitters causes a systematic shift in the output. This shift is linear with static pressure; correct it by performing the [Sensor trim](#).

The following specifications show the static pressure effect for Rosemount 3051 Range 4 and Range 5 Transmitters used in differential pressure applications:

Zero effect

±0.1 percent of the upper range limit per 1000 psi (69 bar) for line pressures from 0 to 2000 psi (0 to 138 bar)

For line pressures above 2000 psi (138 bar), the zero effect error is ±0.2 percent of the upper range limit plus an additional ±0.2 percent of upper range limit error for each 1000 psi (69 bar) of line pressure above 2000 psi (138 bar).

Example

Line pressure is 3000 psi (3 kpsi).

Zero effect error calculation: $\pm(0.2 + 0.2 \times [3 \text{ kpsi} - 2 \text{ kpsi}]) = \pm 0.4$ percent of the upper range limit

Span effect

Correctable to ±0.2 percent of reading per 1000 psi (69 bar) for line pressures from 0 to 3626 psi (0 to 250 bar)

The systematic span shift caused by the application of static line pressure is –1.00 percent of reading per 1000 psi (69 bar) for Range 4 transmitters, and –1.25 percent of reading per 1000 psi (69 bar) for Range 5 transmitters.

6 Troubleshooting

6.1 Section overview

This section contains information on how to troubleshoot the Rosemount™ 3051 Pressure Transmitter with PROFIBUS® PA Protocol.

6.2 Safety messages

Procedures and instructions in this section may require special precautions to ensure the safety of the personnel performing the operations. Information that raises potential safety issues is indicated by a warning symbol (⚠). Refer to the following safety messages before performing an operation preceded by this symbol.

⚠ WARNING

Explosions could result in death or serious injury.

Installation of this transmitter in an explosive environment must be in accordance with the appropriate local, national, and international standards, codes, and practices. Review the approvals section of this Reference Manual for any restrictions associated with a safe installation.

In an explosion-proof/flameproof installation, do not remove the transmitter covers when power is applied to the unit.

Process leaks could result in death or serious injury.

Install and tighten process connectors before applying pressure.

Electrical shock could cause death or serious injury.

Avoid contact with the leads and terminals. High voltage that may be present on leads can cause electrical shock.

6.3 Service support

To expedite the return process outside of the United States, contact the nearest Emerson representative.

Within the United States, call the Emerson Instrument and Valve Response Center using the 1-800-654-RSMT (7768) toll-free number. This center, available 24 hours a day, will assist you with any needed information or materials.

The center will ask for product model and serial numbers, and will provide a Return Material Authorization (RMA) number. The center will also ask for the process material to which the product was last exposed.

⚠ CAUTION

Individuals who handle products exposed to a hazardous substance can avoid injury if they are informed of and understand the hazard. The product being returned will require a copy of the required Material Safety Data Sheet (MSDS) for each substance must be included with the returned goods.

Emerson Instrument and Valve Response Center representatives will explain the additional information and procedures necessary to return goods exposed to hazardous substances.

6.4 Diagnostics and recommended action

The Rosemount 3051 PROFIBUS device diagnostics can be used to warn a user about a potential transmitter error. There is a transmitter error if the output status reads anything but Good or Good - Function Check, or the LCD display reads SNSR or ELECT. Use [Table 6-1](#) to identify what diagnostic condition exists based on the combination of errors under the How to Identify columns. Start with the physical block diagnostic extension and use primary value and temperature status to identify the diagnostic condition. If a box is blank, it is not necessary to identify that diagnostic condition. Once condition is identified, use the What to do column to remedy the error.

Table 6-1: Diagnostics Identification and Recommended Action

Diagnostics	How to identify			What to do
	Diagnostic condition	Class 1 or 2 Master	Class 2 Master	
	Physical block diagnostic extension	Primary value status	Temperature status	
PV Simulation Enabled	Simulate Active	N/A	N/A	<ul style="list-style-type: none"> Check the simulation switch. Replace the electronics.
Pressure beyond sensor limits	Sensor Transducer Block Error	Bad, sensor failure, underflow/overflow	N/A	<ul style="list-style-type: none"> Verify the applied pressure is within the range of the pressure sensor. Check for impulse line plugging or leaks. Replace the sensor module.
Module Temperature Beyond limits	Sensor Transducer Block Error	N/A	Uncertain	<ul style="list-style-type: none"> Verify the sensor temperature is between -45 and 90 °C. Replace the sensor module.
Sensor Module Memory Failure		Bad, out of service (OOS)	N/A	<ul style="list-style-type: none"> Replace sensor module.

Table 6-1: Diagnostics Identification and Recommended Action (continued)

Diagnosics	How to identify			What to do
Diagnostic condition	Class 1 or 2 Master	Class 2 Master		Recommended action
	Physical block diagnostic extension	Primary value status	Temperature status	
No Sensor Module Pressure Updates		Bad, sensor failure, constant	N/A	<ul style="list-style-type: none"> • Check cable connection between sensor module and electronics. • Replace electronics. • Replace sensor module.
No Device Temperature Updates		N/A	Bad	<ul style="list-style-type: none"> • Check cable connection between sensor module and electronics. • Replace electronics. • Replace sensor module.
Circuit Board Memory Failure	Memory Failure or Non Volatile Memory Integrity Error	N/A	N/A	<ul style="list-style-type: none"> • Replace electronics.
LOI button stuck	LOI Button Malfunction	N/A	N/A	<ul style="list-style-type: none"> • Check if button is stuck under housing. • Replace buttons. • Replace electronics.

6.4.1 Extended diagnostics identification with Class 1 Master

If using a Class 1 Master to identify Physical Block Diagnostic Extensions, see [Figure 6-1](#) and [Figure 6-2](#) for diagnostic bit information. [Table 6-2](#) and [Table 6-3](#) list the diagnostic description for each bit.

Note

A Class 2 Master will automatically decode bits and provide diagnostic names.

Figure 6-1: Extended Diagnostics Identification

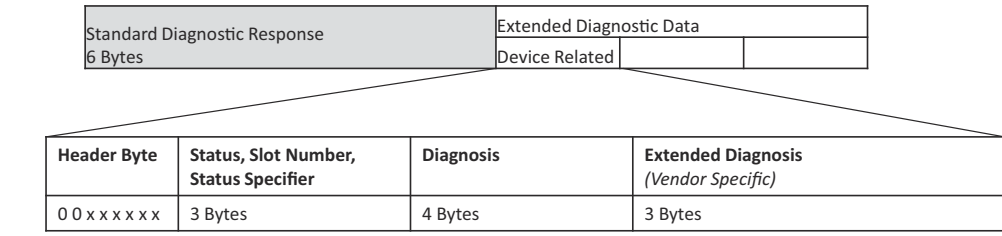
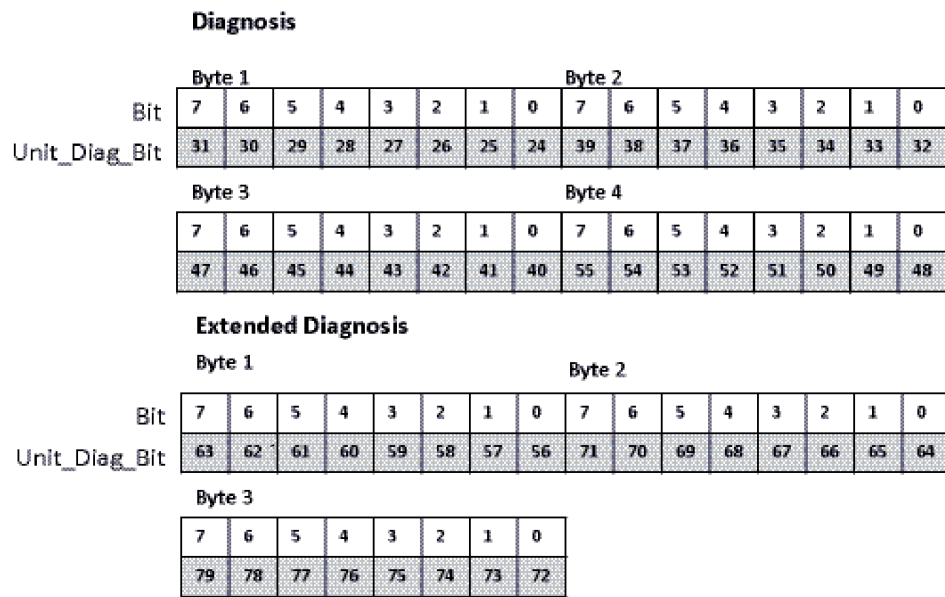

Figure 6-2: Diagnoses and Extended Diagnoses Bit Identification



Note

Unit_Diag_Bit is located in GSD file.

Table 6-2: Device Related Diagnosis Descriptions

Byte-Bit	Unit_Diag_Bit ⁽¹⁾	Diagnostic description
2-4	36	Cold Start
2-3	35	Warm Start
3-2	42	Function Check
3-0	40	Maintenance Alarm
4-7	55	More Information Available

(1) Unit_Diag_Bit is located in GSD file.

Table 6-3: Extended Diagnosis Descriptions

Diagnostic extension Byte-Bit	Unit_Diag_Bit ⁽¹⁾	Diagnostic description
1-4	28	Simulate Active
1-7	63	Other
2-0	64	Out-of-Service
2-1	65	Power-Up
2-2	66	Device Needs Maintenance now
2-4	68	Lost NV Data
2-5	69	Lost Static Data
2-6	70	Memory Failure
3-1	73	ROM Integrity Error
Diagnostic extension Byte-Bit	Unit_Diag_Bit ⁽¹⁾	Diagnostic description
3-3	75	Non-Volatile Memory Integrity Error
3-4	76	Hardware/Software Incompatible
3-5	77	Manufacturing Block Integrity Error
3-6	78	Sensor Transducer Block Error
3-7	79	LOI Button Malfunction is detected

(1) Unit_Diag_Bit is located in GSD file.

6.5 Plantweb™ and NE107 diagnostics

Table 6-4 describes the recommended status of each diagnostic condition based on Plantweb and NAMUR NE107 recommendations.

Table 6-4: Output Status

Name	Plantweb alert category	NE107 category
PV Simulation Enabled	Advisory	Check
LOI button pressed	Advisory	Good
Pressure beyond sensor limits	Maintenance	Failure
Module Temperature Beyond limits	Maintenance	Out of spec
Sensor Module Memory Failure	Failure	Failure
No Sensor Module Pressure Updates	Failure	Failure
No Device Temperature Updates	Failure	Out of spec
Circuit Board Memory Failure	Failure	Failure
LOI button stuck	Failure	Failure

6.6 Alert messages and fail safe type selection

Table 6-5 defines the output status and LCD display messages that will be driven by a diagnostic condition. This table can be used to determine what type of fail safe value setting is preferred. Fail safe type can be set with a Class 2 Master under **Fail Safe** → **Fail Safe Mode**.

Table 6-5: Alert Messages

Diagnostic	Output status (based on fail safe type)			LCD display
	Name	Use fail safe value	Use last good value	
PV Simulation Enabled	Depends on simulated value/status	Depends on simulated value/status	Depends on simulated value/status	N/A
LOI button pressed	Good, function check	Good, function check	Good, function check	N/A
Pressure beyond sensor limits	Uncertain, substitute set	Uncertain, substitute set	Bad, process related, maintenance alarm	SNSR
Module Temperature Beyond limits	Uncertain, substitute set	Uncertain, process related, no maintenance	Uncertain, process related, no maintenance	SNSR
Sensor Module Memory Failure	Bad, passivated	Uncertain, substitute set	Bad, maintenance alarm	SNSR
No Sensor Module Pressure Updates	Uncertain, substitute set	Uncertain, substitute set	Bad, process related, maintenance alarm	SNSR
No Device Temperature Updates	Uncertain, process related, no maintenance	Uncertain, process related, no maintenance	Uncertain, process related, no maintenance	SNSR
Circuit Board Memory Failure	Bad, passivated	Bad, passivated	Bad, passivated	ELECT
LOI button stuck	Bad, passivated	Bad, passivated	Bad, passivated	ELECT

Table 6-6: Output Status Bit Definition

Description	HEX	DECIMAL
Bad - passivated	0x23	35
Bad, maintenance alarm, more diagnostics available	0x24	36
Bad, process related - no maintenance	0x28	40
Uncertain, substitute set	0x4B	75
Uncertain, process related, no maintenance	0x78	120

Table 6-6: Output Status Bit Definition (continued)

Description	HEX	DECIMAL
Good, ok	0x80	128
Good, update event	0x84	132
Good, advisory alarm, low limit	0x89	137
Good, advisory alarm, high limit	0x8A	138
Good, critical alarm, low limit	0x8D	141
Good, critical alarm, high limit	0x8E	142
Good, function check	0xBC	188

6.7 Disassembly procedures

Do not remove the instrument cover in explosive atmospheres when the circuit is live.

6.7.1 Remove from service

Follow these steps:

Procedure

1. Follow all plant safety rules and procedures.
2. Isolate and vent the process from the transmitter before removing the transmitter from service.
3. Remove all electrical leads and disconnect conduit.
4. Remove the transmitter from the process connection.
5. The Rosemount 3051C Transmitter is attached to the process connection by four bolts and two cap screws. Remove the bolts and separate the transmitter from the process connection. Leave the process connection in place and ready for re-installation.
6. The Rosemount 3051T transmitter is attached to the process by a single hex nut process connection. Loosen the hex nut to separate the transmitter from the process. Do not wrench on neck of transmitter.
7. Do not scratch, puncture, or depress the isolating diaphragms.
8. Clean isolating diaphragms with a soft rag and a mild cleaning solution, and rinse with clear water.
9. For the Rosemount 3051C, when removing the process flange or flange adapters, visually inspect the PTFE O-rings. Replace the O-rings if they show any signs of damage, such as nicks or cuts. Undamaged O-rings may be reused.

6.7.2 Remove terminal block

Electrical connections are located on the terminal block in the compartment labeled “FIELD TERMINALS.”

Procedure

1. Remove the housing cover from the field terminal side.
2. Loosen the two small screws located on the assembly in the nine o'clock and five o'clock positions.
3. Pull the entire terminal block out to remove it.

6.7.3 Remove the electronics board

The transmitter electronics board is located in the compartment opposite the terminal side. To remove the electronics board, perform the following procedure.

Procedure

1. Remove the housing cover opposite the field terminal side.
2. If disassembling a transmitter with a LCD display, loosen the two captive screws visible on the right and left side of the meter display.
3. Loosen the two captive screws that anchor the board to the housing. The electronics board is electrostatically sensitive; observe handling precautions for static-sensitive components. Use caution when removing the LCD display as there is an electronic pin connector that interfaces between the LCD display and electronics board. The two screws anchor the LCD display to the electronics board and the electronics board to the housing.
4. Using the two captive screws, slowly pull the electronics board out of the housing. The sensor module ribbon cable holds the electronics board to the housing. Disengage the ribbon cable by pushing the connector release.

6.7.4 Remove the sensor module from the electronics housing

Procedure

1. Remove the electronics board (see [Remove the electronics board](#)).

Important

To prevent damage to the sensor module ribbon cable, disconnect it from the electronics board before removing the sensor module from the electrical housing.

2. Carefully tuck the cable connector completely inside of the internal black cap.

Note

Do not remove the housing until after tucking the cable connector completely inside of the internal black cap. The black cap protects the ribbon cable from damage that can occur when rotating the housing.

3. Loosen the housing rotation set screw with a -in. hex wrench, and loosen one full turn.
4. Unscrew the module from the housing, making sure the black cap and sensor cable do not catch on the housing.

6.8 Reassembly procedures

Procedure

1. Inspect all cover and housing (non-process wetted) O-rings and replace if necessary. Lightly grease with silicone lubricant to ensure a good seal.
2. Carefully tuck the cable connector completely inside the internal black cap; turn the black cap and cable counterclockwise one rotation to tighten the cable.
3. Lower the electronics housing onto the module. Guide the internal black cap and cable through the housing and into the external black cap.
4. Turn the module clockwise into the housing.

Important

Make sure the sensor ribbon cable and internal black cap remain completely free of the housing while rotating. Damage can occur to the cable if the internal black cap and ribbon cable become hung up and rotate with the housing.

5. Thread the housing completely onto the sensor module. The housing must be no more than one full turn from flush with the sensor module to comply with explosion proof requirements.
6. Tighten the housing rotation set screw using a -in. hex wrench.

6.8.1 Attach the electronics board

Procedure

1. Remove the cable connector from its position inside of the internal black cap and attach it to the electronics board.
2. Using the two captive screws as handles, insert the electronics board into the housing. Make sure the posts from the electronics housing properly engage the receptacles on the electronics board. Do not force. The electronics board should slide gently on the connections.
3. Tighten the captive mounting screws.
4. Replace the electronics housing cover. The transmitter covers must be engaged metal-to-metal to ensure a proper seal and to meet explosion-proof requirements.

6.8.2 Install the terminal block

Procedure

1. Gently slide the terminal block into place, making sure the two posts from the electronics housing properly engage the receptacles on the terminal block.
2. Tighten the captive screws.

3. Replace the electronics housing cover. The transmitter covers must be fully engaged to meet explosion-proof requirements.

6.8.3 Reassemble the Rosemount 3051C process flange

Procedure

1. Inspect the sensor module PTFE O-rings. Undamaged O-rings may be reused. Replace O-rings that show any signs of damage, such as nicks, cuts, or general wear.

Note

If replacing the O-rings, be careful not to scratch the O-ring grooves or the surface of the isolating diaphragm when removing the damaged O-rings.

2. Install the process connection. Possible options include:
 3. Coplanar process flange
 - a) Hold the process flange in place by installing the two alignment screws to finger tightness (screws are not pressure retaining). Do not overtighten as this will affect module-to-flange alignment.
 - b) Install the four 1.75 -in. (44.45 mm) flange bolts by finger tightening them to the flange.
 4. Coplanar process flange with flange adapters
 - a) Hold the process flange in place by installing the two alignment screws to finger tightness (screws are not pressure retaining). Do not overtighten as this will affect module-to-flange alignment.
 - b) Hold the flange adapters and adapter O-rings in place while installing the four configurations, use four 2.88 -in. (73.15 mm) bolts. For gage pressure configurations, use two 2.88 -in. (73.15 mm) bolts and two 1.75 -in. (44.45 mm) bolts.
 5. Manifold
 - a) Contact the manifold manufacturer for the appropriate bolts and procedures.
6. Tighten the bolts to the initial torque value using a crossed pattern. See [Table 6-7](#) for appropriate torque values.

Table 6-7: Bolt Installation Torque Values

Bolt material	Initial torque value	Final torque value
CS-ASTM-A445 Standard	300 in-lb (34 N-m)	650 in-lb (73 N-m)
316 SST—Option L4	150 in-lb (17 N-m)	300 in-lb (34 N-m)
ASTM-A-193-B7M—Option L5	300 in-lb (34 N-m)	650 in-lb (73 N-m)
ASTM-A-193 class 2, Grade B8M—Option L8	150 in-lb (17 N-m)	300 in-lb (34 N-m)

Note

If replacing the PTFE sensor module O-rings, re-torque the flange bolts after installation to compensate for cold flow.

Note

After replacing O-rings on Range 1 transmitters and re-installing the process flange, expose the transmitter to a temperature of 185 °F (85 °C) for two hours. Then re-tighten the flange bolts in a cross pattern, and again expose the transmitter to a temperature of 185 °F (85 °C) for two hours before calibration.

6.8.4 Install the drain/vent valve

Procedure

1. Apply sealing tape to the threads on the seat. Starting at the base of the valve with the threaded end pointing toward the installer, apply two clockwise turns of sealing tape.
2. Tighten the drain/vent valve to 250 in-lb (28.25 N-m).
3. Take care to place the opening on the valve so that process fluid will drain toward the ground and away from human contact when the valve is opened.

A Reference data

A.1 Product Certifications

To view current Rosemount 3051 Pressure Transmitter Product Certifications, follow these steps:

Procedure

1. Go to [Emerson.com/Rosemount/Rosemount-3051](https://emerson.com/Rosemount/Rosemount-3051).
2. Scroll as needed to the green menu bar and click Documents & Drawings.
3. Click Manuals & Guides.
4. Select the appropriate Quick Start Guide.

A.2 Ordering Information, Specifications, and Drawings

To view current Rosemount 3051 Pressure Transmitter Ordering Information, Specifications, and Drawings, follow these steps:

Procedure

1. Go to [Emerson.com/Rosemount/Rosemount-3051](https://emerson.com/Rosemount/Rosemount-3051).
2. Scroll as needed to the green menu bar and click Documents & Drawings.
3. For installation drawings, click Drawings & Schematics.
4. Select the appropriate document.

For ordering information, specifications, and dimensional drawings, click Data Sheets & Bulletins and select the appropriate Product Data Sheet.

B Local Operator Interface (LOI) Menu

B.1 Overview

This appendix contains the complete LOI menu.

B.2 Safety messages

Procedures and instructions in this section may require special precautions to ensure the safety of the personnel performing the operations. Information that raises potential safety issues is indicated by a warning symbol (⚠). Refer to the following safety messages before performing an operation preceded by this symbol.

⚠ WARNING

Explosions could result in death or serious injury.

Installation of this transmitter in an explosive environment must be in accordance with the appropriate local, national, and international standards, codes, and practices. Review the approvals section of this Reference Manual for any restrictions associated with a safe installation.

In an explosion-proof/flameproof installation, do not remove the transmitter covers when power is applied to the unit.

Process leaks could result in death or serious injury.

Install and tighten process connectors before applying pressure.

Electrical shock could cause death or serious injury.

Avoid contact with the leads and terminals. High voltage that may be present on leads can cause electrical shock.

C PROFIBUS® Block Information

C.1 Overview

This appendix contains PROFIBUS block and parameter information.

C.2 Safety messages

Procedures and instructions in this section may require special precautions to ensure the safety of the personnel performing the operations. Information that raises potential safety issues is indicated by a warning symbol (⚠). Refer to the following safety messages before performing an operation preceded by this symbol.

⚠ WARNING

Explosions could result in death or serious injury.

Installation of this transmitter in an explosive environment must be in accordance with the appropriate local, national, and international standards, codes, and practices. Review the approvals section of this Reference Manual for any restrictions associated with a safe installation.

In an explosion-proof/flameproof installation, do not remove the transmitter covers when power is applied to the unit.

Process leaks could result in death or serious injury.

Install and tighten process connectors before applying pressure.

Electrical shock could cause death or serious injury.

Avoid contact with the leads and terminals. High voltage that may be present on leads can cause electrical shock.

C.3 PROFIBUS block parameters

Table C-1 through Table C-3 can be used to cross reference parameters from the PROFIBUS specification, Class 2 Master, and Local Operator Interface (LOI).

Table C-1: Physical Block Parameters

Index	Parameter name	DTM™ name	LOI location	Definition
0	BLOCK OBJECT	Block Object	N/A	N/A
1	ST_REV	Static Revision No.	N/A	The revision level of the static data associated with block; the revision value will be incremented each time a static parameter value in the block is changed.

Table C-1: Physical Block Parameters (continued)

Index	Parameter name	DTM™ name	LOI location	Definition
2	TAG_DESC	Tag	N/A	The user description of the intended block application.
3	STRATEGY	Strategy	N/A	Grouping of function blocks.
4	ALERT_KEY	Alert Key	N/A	The identification number of the plant unit. This information may be used in the host for sorting alarms, etc.
5	TARGET_MODE	Target Mode	N/A	Contains desired mode of the block normally set by the operator or a control specification.
6	MODE_BLK	Actual Mode	N/A	Contains the actual, permitted, and normal modes of the block.
7	ALARM_SUM		N/A	Contains the current states of the block alarms
8	SOFTWARE_REVISION	Software Revision	N/A	Software revision, includes a major, minor, and build revision.
9	HARDWARE_REVISION	Hardware Revision	N/A	Hardware revision
10	DEVICE_MAN_ID	Manufacturer	N/A	Identification code of the manufacturer of the field device
11	DEVICE_ID	Device ID	N/A	Identification of the device (Rosemount 3051)
12	DEVICE_SER_NUM	Device Serial Num	N/A	Serial number of the device (output board serial number).
13	DIAGNOSIS	Diagnosis	N/A	Detailed information of the device bitwise coded. MSB (bit 31) represents more information available in Diagnosis extension.
14	DIAGNOSIS_EXTENSION	Diagnosis Extension	N/A	Additional manufacturer diagnoses information (See DIAGNOSIS_EXTENSION table below).
15	DIAGNOSIS_MASK	N/A	N/A	Definition of supported DIAGNOSIS information bits
16	DIAGNOSIS_MASK_EXTENSION	N/A	N/A	Definition of supported DIAGNOSIS_EXTENSION information bits
18	WRITE_LOCKING	Write Locking	N/A	Software write protection
19	FACTORY_RESET	Factory Reset	N/A	Command for restarting device
20	DESCRIPTOR	Descriptor	N/A	User-definable text to describe the device.
21	DEVICE_MESSAGE	Message	N/A	User-definable message to the device or application in plant.
22	DEVICE_INSTAL_DATE	Installation Date	N/A	Date of installation of the device.

Table C-1: Physical Block Parameters (continued)

Index	Parameter name	DTM™ name	LOI location	Definition
23	LOCAL_OP_ENA	LOI Enable	N/A	Disable/enable the optional Local Operator Interface (LOI)
24	IDENT_NUMBER_SELECTOR	Ident Number Selector	IDENT	Specifies the cyclic behavior of a device which is described in the corresponding GSD file
25	HW_WRITE_PROTECTION	HW Write Protection	N/A	Status of the security jumper
26	FEATURE	Optional Device Features	N/A	Indicates optional features implemented in the device
27	COND_STATUS_DIAG	N/A	N/A	Indicates the mode of a device that can be configured for status and diagnostic behavior
33	FINAL_ASSEMBLY_NUM	Final Assembly Number	N/A	The same final assembly number placed on the neck label
34	DOWNLOAD_MODE	Factory Upgrade	N/A	Puts the device into a manufacturer mode for upgrading the device
35	PASSCODE_LOI	Password	PSSWD	Password for the LOI
36	LOI_DISPLAY_SELECTION	Display Selection	DISP	Indicates process variables shown on the local display
37	LOI_BUTTON_STATE	Button State	N/A	Status of the optional LOI buttons
38	VENDOR_IDENT_NUMBER	Vendor Ident Number	IDENT	0x4444
39	LOI_PRESENT	LOI Present	N/A	Parameter written during manufacturing to indicate if an optional LOI is present
40	HW_SIMULATE_PROTECTION	HW Simulation Protection	N/A	Status of hardware simulation jumper

Table C-2: Transducer Block Parameters

Index	Parameter name	DTM name	LOI location	Definition
1	ST_REV	Static Revision No.	N/A	The revision level of the static data associated with block; the revision value will be incremented each time a static parameter value in the block is changed.
2	TAG_DESC	Tag	N/A	The user description of the intended block application.
3	STRATEGY	Strategy	N/A	Grouping of function blocks.
4	ALERT_KEY	Alert Key	N/A	The identification number of the plant unit. This information may be used in the host for sorting alarms, etc.

Table C-2: Transducer Block Parameters (continued)

Index	Parameter name	DTM name	LOI location	Definition
5	TARGET_MODE	Target Mode	N/A	Contains desired mode of the block normally set by the operator or a control specification.
6	MODE_BLK	Actual Mode	N/A	Contains the actual, permitted, and normal modes of the block.
7	ALARM_SUM	N/A	N/A	Contains the current states of the block alarms
8	SENSOR_VALUE	Pressure raw value	N/A	Raw sensor value, untrimmed, in SENSOR_UNIT
9	SENSOR_HI_LIM	Upper Sensor Limit	N/A	Upper sensor range value, in SENSOR_UNIT
10	SENSOR_LO_LIM	Lower Sensor Limit	N/A	Lower sensor range value, in SENSOR_UNIT
11	CAL_POINT_HI	Upper Calibration Point	CALIB-> UPPER	The value of the sensor measurement used for the high calibration point. Unit is derived from SENSOR_UNIT
12	CAL_POINT_LO	Lower Calibration Point	CALIB-> LOWER	The value of the sensor measurement used for the low calibration point. Unit is derived from SENSOR_UNIT
13	CAL_MIN_SPAN	Calibration Min Span	N/A	The minimum span that is allowed between the calibration high and low points.
14	SENSOR_UNIT	Sensor Unit	UNITS	Engineering units for the calibration values
15	TRIMMED_VALUE	Pressure Trimmed Value	UNITS	Contains the sensor value after the trim processing. Unit is derived from SENSOR_UNIT
16	SENSOR_TYPE	Sensor Type	N/A	Sensor type (capacitance, strain gauge)
18	SENSOR_SERIAL_NUMMER	Sensor Serial Number	N/A	Sensor serial number
19	PRIMARY_VALUE	Primary Value	N/A	Measured value and status available to the Function Block. The unit of PRIMARY_VALUE is the PRIMARY_VALUE_UNIT.
20	PRIMARY_VALUE_UNIT	Unit (PV)	N/A	Engineering units for the primary value
21	PRIMARY_VALUE_TYPE	Primary Value Type	N/A	Type of pressure application (pressure, flow, level)
22	SENSOR_DIAPHRAGM_MATERIAL	Isolator Material	N/A	Type of material of the sensor isolator
23	SENSOR_FILL_FLUID	Module Fill Fluid	N/A	Type of fill fluid used in sensor
24	SENSOR_O_RING_MATERIAL	O-ring Material	N/A	Type of material of the flange O-rings

Table C-2: Transducer Block Parameters (continued)

Index	Parameter name	DTM name	LOI location	Definition
25	PROCESS_CONNECTION_TYPE	Process Connection Type	N/A	Type of flange that is attached to the device
26	PROCESS_CONNECTION_MATERIAL	Process Connection Material	N/A	Type of material of the flange
27	TEMPERATURE	Temperature	N/A	Sensor temperature, in TEMPERATURE_UNIT
28	TEMPERATURE_UNIT	Temperature Unit	UNITS	Engineering units of the sensor temperature
29	SECONDARY_VALUE_1	Secondary Value 1	UNITS	Trimmed pressure value, unscaled, in SECONDARY_VALUE_1_UNIT
30	SECONDARY_VALUE_1_UNIT	Unit (Secondary Value 1)	UNITS	Engineering unit of SECONDARY_VALUE_1
31	SECONDARY_VALUE_2	Secondary Value 2	UNITS	Measured value after input scaling
33	LIN_TYPE	Characterization type	UNITS	Linearization type
34	SCALE_IN	Scale in	UNITS	Input scaling in SECONDARY_VALUE_1_UNIT
35	SCALE_OUT	Scale out	UNITS	Output scaling in PRIMARY_VALUE_UNIT
36	LOW_FLOW_CUT_OFF	Low Flow Cut Off	UNITS-> FLOW	This is the point in percent of flow until the output of the flow function is set to zero. It is used for suppressing low flow values
59	FACT_CAL_RECALL	Restore Calibration Factory	CALIB-> RESET	Recalls the sensor calibration set at the factory
60	SENSOR_CAL_METHOD	Sensor Calibration Factor	N/A	The method of last sensor calibration.
61	SENSOR_VALUE_TYPE	Transmitter Type	N/A	Type of pressure measurement (differential, absolute, gage)

Table C-3: Analog input Block Parameters

Index	Parameter name	DTM name	LOI location	Definition
1	ST_REV	Static Revision No.	N/A	The revision level of the static data associated with block; the revision value will be incremented each time a static parameter value in the block is changed.
2	TAG_DESC	Tag	N/A	The user description of the intended block application.

Table C-3: Analog input Block Parameters (continued)

Index	Parameter name	DTM name	LOI location	Definition
3	STRATEGY	Strategy	N/A	Grouping of function blocks.
4	ALERT_KEY	Alert Key	N/A	The identification number of the plant unit. This information may be used in the host for sorting alarms, etc.
5	TARGET_MODE	Target Mode	N/A	Contains desired mode of the block normally set by the operator or a control specification.
6	MODE_BLK	Actual Mode	N/A	Contains the actual, permitted, and normal modes of the block.
7	ALARM_SUM	Alarm Summary	N/A	Contains the current states of the block alarms
8	BATCH	Batch Information	N/A	Used in Batch applications according to IEC 61512-1
10	OUT	Value (Output)	N/A	Value and status of the block output.
11	PV_SCALE	PV Scale	N/A	Conversion of the Process Variable into percent using the high and low scale value, in TB.PRIMARY_VALUE_UNIT
12	OUT_SCALE	Output Scale	N/A	The high and low scale values, units code, and number of digits to the right of the decimal point associated with OUT.
13	LIN_TYPE	Characterization Type	N/A	Linearization type
14	CHANNEL	Channel	N/A	Used to select the Transducer Block measurement value. Always 0x112.
16	PV_FTIME	Filter Time Const	DAMP	The time constant of the first order PV filter. Time required for a 63% change in the input value (seconds).
17	FSAFE_TYPE	Fail Safe Mode	N/A	Defines the reaction of the device, if a fault is detected
18	FSAFE_VALUE	Fail Safe Default Value	N/A	Default value for the OUT parameter, in OUT_SCALE units, if a sensor or sensor electronic fault is detected
19	ALARM_HYS	Limit Hysteresis	N/A	The amount the alarm value must return within the alarm limit before the associated active alarm condition clears.
21	HI_HI_LIM	Upper Limit Alarm Limits	N/A	The setting of the alarm limit used to detect the HI HI alarm condition.
23	HI_LIM	Upper Limit Warning Limits	N/A	The setting of the alarm limit used to detect the HI alarm condition.
25	LO_LIM	Lower Limit Warning Limits	N/A	The setting of the alarm limit used to detect the LO alarm condition.
27	LO_LO_LIM	Lower Limit Alarm Limits	N/A	The setting of the alarm limit used to detect the LO LO alarm condition.
30	HI_HI_ALM	Upper Limit Alarm	N/A	The HI Hi alarm data.

Table C-3: Analog input Block Parameters (continued)

Index	Parameter name	DTM name	LOI location	Definition
31	HI_ALM	Upper Limit Warning	N/A	The HI alarm data
32	LO_ALM	Lower Limit Warning	N/A	The LO alarm data.
33	LO_LO_ALM	Lower Limit Alarm	N/A	The LO LO alarm data.
34	SIMULATE	Simulation	N/A	A group of data that contains the simulated transducer value and status, and the enable/disable bit.

C.4 Condensed status

The Rosemount 3051 device utilizes condensed status as recommended by the Profile 3.02 specification and NE 107. Condensed status has some additional bits and changed bit assignments from classic status. Confirm bit assignment using [Table C-4](#) and [Table C-5](#).

Table C-4: Diagnosis Descriptions

Device related diagnosis		
Byte-Bit	Unit_Diag_Bit	Diagnostic description
2-4	36	Cold Start
2-3	35	Warm Start
3-2	42	Function Check
3-0	40	Maintenance Alarm
4-7	55	More Information Available

Table C-5: Output Status Bit Definition

Description	HEX	DECIMAL
Bad - passivated	0x23	35
Bad, maintenance alarm, more diagnostics available	0x24	36
Bad, process related - no maintenance	0x28	40
Uncertain, substitute set	0x4B	75
Uncertain, process related, no maintenance	0x78	120
Good, ok	0x80	128
Good, update event	0x84	132
Good, advisory alarm, low limit	0x89	137
Good, advisory alarm, high limit	0x8A	138
Good, critical alarm, low limit	0x8D	141
Good, critical alarm, high limit	0x8E	142
Good, function check	0xBC	188

Global Headquarters

Emerson Automation Solutions
6021 Innovation Blvd.
Shakopee, MN 55379, USA

📞 +1 800 999 9307 or +1 952 906 8888
☎ +1 952 204 8889
✉ RFQ.RMD-RCC@Emerson.com

North America Regional Office

Emerson Automation Solutions
8200 Market Blvd.
Chanhassen, MN 55317, USA

📞 +1 800 999 9307 or +1 952 906 8888
☎ +1 952 204 8889
✉ RMT-NA.RCCRFQ@Emerson.com

Latin America Regional Office

Emerson Automation Solutions
1300 Concord Terrace, Suite 400
Sunrise, FL 33323, USA

📞 +1 954 846 5030
☎ +1 954 846 5121
✉ RFQ.RMD-RCC@Emerson.com

Europe Regional Office

Emerson Automation Solutions Europe
GmbH
Neuhofstrasse 19a P.O. Box 1046
CH 6340 Baar
Switzerland

📞 +41 (0) 41 768 6111
☎ +41 (0) 41 768 6300
✉ RFQ.RMD-RCC@Emerson.com

Asia Pacific Regional Office

Emerson Automation Solutions
1 Pandan Crescent
Singapore 128461

📞 +65 6777 8211
☎ +65 6777 0947
✉ Enquiries@AP.Emerson.com

Middle East and Africa Regional Office

Emerson Automation Solutions
Emerson FZE P.O. Box 17033
Jebel Ali Free Zone - South 2
Dubai, United Arab Emirates

📞 +971 4 8118100
☎ +971 4 8865465
✉ RFQ.RMTMEA@Emerson.com

 [Linkedin.com/company/Emerson-Automation-Solutions](https://www.linkedin.com/company/Emerson-Automation-Solutions)

 [Twitter.com/Rosemount_News](https://twitter.com/Rosemount_News)

 [Facebook.com/Rosemount](https://www.facebook.com/Rosemount)

 [Youtube.com/user/RosemountMeasurement](https://www.youtube.com/user/RosemountMeasurement)

©2020 Emerson. All rights reserved.

Emerson Terms and Conditions of Sale are available upon request. The Emerson logo is a trademark and service mark of Emerson Electric Co. Rosemount is a mark of one of the Emerson family of companies. All other marks are the property of their respective owners.