

Rosemount™ 3051 Wireless Pressure Transmitters

Pressure, Level, and Flow Solutions with WirelessHART® Protocol



Safety messages

⚠ WARNING

Refer to the *Product certifications* section of this Quick Start Guide documentation when using the RFID tag (option code Y3) for required installation conditions.

Safety Messages

NOTICE

Read this document before working with the product. For personal and system safety, and for optimum product performance, ensure you thoroughly understand the contents before installing, using, or maintaining this product. For technical assistance, see [Emerson.com/global](https://emerson.com/global).

⚠ WARNING

Failure to follow these installation guidelines could result in death or serious injury.

Ensure only qualified personnel perform the installation.

Explosions could result in death or serious injury.

Installation of this transmitter in an explosive environment must be in accordance with the appropriate local, national, and international standards, codes, and practices. Review the approvals section of the *Quick Start Guide* for any restrictions associated with a safe installation.

Before connecting a handheld communicator in an explosive atmosphere, ensure that the instruments are installed in accordance with intrinsically safe or non-incendive field wiring practices.

Verify that the operating atmosphere of the transmitter is consistent with the appropriate hazardous locations certifications.

Process leaks could result in death or serious injury.

Install and tighten process connectors before applying pressure.

Electrical shock could cause death or serious injury.

Avoid contact with the leads and terminals. High voltage that may be present on leads can cause electrical shock.

This device complies with Part 15 of the Federal Communication Commission (FCC) Rules. Operation is subject to the following conditions: This device may not cause harmful interference. This device must accept any interference received, including interference that may cause undesired operation.

This device must be installed to ensure a minimum antenna separation distance of 8-in. (20 cm) from all persons.

Replacement equipment or spare parts not approved by Emerson for use as spare parts could reduce the pressure retaining capabilities of the transmitter and may render the instrument dangerous.

Use only bolts supplied or sold by Emerson as spare parts.

Improper assembly of manifolds to traditional flange can damage sensor module.

For safe assembly of manifold to traditional flange, bolts must break back plane of flange web (also called bolt hole) but must not contact sensor module housing. The power module with the wireless unit contains a primary lithium-thionyl chloride battery. Each power module contains approximately 5.0 grams of lithium. Under normal conditions, the power module materials are self-contained and are not reactive as long as the batteries and the pack integrity are maintained. Care should be taken to prevent thermal, electrical or mechanical damage. Contacts should be protected to prevent premature discharge.

NOTICE

The products described in this document are NOT designed for nuclear-qualified applications. Using non-nuclear qualified products in applications that require nuclear-qualified hardware or products may cause inaccurate readings. For information on Emerson nuclear-qualified products, contact your local Emerson Sales Representative.

NOTICE

The Rosemount 3051 Wireless and all other wireless devices should be installed only after the Smart Wireless Gateway has been installed and is functioning properly. Wireless devices should also be powered up in order of proximity from the Smart Wireless Gateway, beginning with the closest. This will result in a simpler and faster network installation.

Shipping considerations for wireless products (lithium batteries: green power module, model number 701PGNKF).

The unit was shipped to you without the power module installed. Remove the power module from the unit prior to shipping.

Each power module contains one "D" size primary lithium-thionyl chloride battery. Primary lithium batteries are regulated in transportation by the U.S. Department of Transportation, and are also covered by International Air Transport Association (IATA), International Civil Aviation Organization (ICAO), and ARD (European Ground Transportation of Dangerous Goods). It is the responsibility of the shipper to ensure compliance with these or any other local requirements. Consult current regulations and requirements before shipping.

The power module with the wireless unit contains one "D" size primary lithium-thionyl chloride battery (green power module, model number 701PGNKF). Each battery contains approximately 5.0 grams of lithium. Under normal conditions, the battery materials are self-contained and are not reactive as long as the battery and the pack integrity are maintained. Care should be taken to prevent thermal, electrical or mechanical damage. Contacts should be protected to prevent premature discharge.

Battery hazards remain when cells are discharged.

Power modules should be stored in a clean and dry area. For maximum battery life, storage temperature should not exceed 30 °C (86 °F).

The power module may be replaced in a hazardous area. The power module has surface resistivity greater than one gigaohm and must be properly installed in the wireless device enclosure. Care must be taken during transportation to and from the point of installation to prevent electrostatic charge build-up.

Using the Rosemount 3051 Wireless in a manner other than what is specified by the manufacturer may impair the protection provided by the equipment.

⚠ WARNING

Physical access

Unauthorized personnel may potentially cause significant damage to and/or misconfiguration of end users' equipment. This could be intentional or unintentional and needs to be protected against.

Physical security is an important part of any security program and fundamental in protecting your system. Restrict physical access by unauthorized personnel to protect end users' assets. This is true for all systems used within the facility.

Contents

Chapter 1	Introduction.....	7
	1.1 Models covered.....	7
	1.2 Product recycling/disposal.....	7
Chapter 2	Configuration.....	9
	2.1 Overview.....	9
	2.2 Required bench top configuration.....	9
	2.3 Basic setup.....	10
	2.4 Configure for pressure.....	12
	2.5 Configure for level and flow.....	14
	2.6 Review configuration data.....	16
	2.7 Configuring the LCD display.....	18
	2.8 Detailed transmitter setup.....	19
	2.9 Diagnostics and service.....	21
	2.10 Advanced functions for HART Protocol.....	23
Chapter 3	Installation.....	25
	3.1 Overview.....	25
	3.2 Installation considerations.....	25
	3.3 Installation procedures.....	28
	3.4 Rosemount 305, 306, and 304 manifolds.....	42
Chapter 4	Commissioning.....	59
	4.1 Overview.....	59
	4.2 Viewing network status.....	59
	4.3 Verifying operation.....	60
	4.4 Configuring transmitter security.....	62
Chapter 5	Operation and Maintenance.....	65
	5.1 Overview.....	65
	5.2 Calibration overview.....	65
	5.3 Trim the pressure signal.....	68
	5.4 LCD display screen messages.....	73
Chapter 6	Troubleshooting	85
	6.1 Overview.....	85
	6.2 Electronics failure.....	85
	6.3 Radio failure.....	85
	6.4 Supply voltage failure.....	85
	6.5 Electronics warning.....	85
	6.6 Pressure has exceeded limits.....	85
	6.7 Electronics temperature has exceeded limits.....	86
	6.8 Supply voltage low.....	86
	6.9 Database memory warning.....	86
	6.10 Configuration error.....	86

6.11	HI HI alert.....	87
6.12	HI alert.....	87
6.13	LO alert.....	87
6.14	LO LO alert.....	87
6.15	Button stuck.....	88
6.16	Simulation Active.....	88
6.17	Transmitter will not respond to changes in applied pressure.....	88
6.18	Digital pressure variable reading is low or high.....	88
6.19	Digital pressure variable reading is erratic.....	89
6.20	LCD display is not functioning.....	89
6.21	Device not joining the network.....	89
6.22	Short battery life.....	89
6.23	Limited bandwidth error.....	89
6.24	Removing from service.....	90
Chapter 7	Reference Data.....	91
7.1	Ordering information, specifications, and drawing.....	91
7.2	Product certifications.....	91
Appendix A	Network Design Best Practices.....	93
A.1	Effective range.....	93
Appendix B	Communication Device Menu Trees and Fast Keys.....	95
B.1	Communication Device menu tree.....	95
B.2	Communication Device Fast Keys.....	98

1 Introduction

1.1 Models covered

The following transmitters are covered by this manual:

- Rosemount 3051C Coplanar™ Pressure Transmitter
 - Measures differential and gage pressure up to 2000 psi (137.9 bar)
 - Measures absolute pressure up to 4000 psi (275.8 bar)
- Rosemount 3051T In-line Pressure Transmitter
 - Measures gage/absolute pressure up to 10000 psi (689.5 bar)
- Rosemount 3051L Level Transmitter
 - Measures level and specific gravity up to 300 psi (20.7 bar)
- Rosemount 3051CF Flowmeters
 - Measures flow in line sizes from 1/2-in. (15 mm) to 96-in. (2400 mm)

1.2 Product recycling/disposal

Consider recycling equipment and packaging.

Dispose of the product and packaging in accordance with local and national legislation.

2 Configuration

2.1 Overview

This section contains information on commissioning and tasks that should be performed on the bench prior to installation.

Communication Device and AMS Device Manager instructions are given to perform configuration functions. For convenience, Communication Device Fast Key sequences are labeled “Fast Keys” for each software function below the appropriate headings.

Full Communication Device menu trees and Fast Key sequences are available in [Communication Device Menu Trees and Fast Keys](#).

2.2 Required bench top configuration

Bench top configuration requires a Communication Device, AMS Device Manager, or any *WirelessHART*[®] Communicator. Connect the Communication Device leads to the terminals labeled system output on the Power Module. See [Figure 2-1](#).

Bench top configuration consists of testing the transmitter and verifying transmitter configuration data. Rosemount 3051 Wireless Transmitters must be configured before installation. Configuring the transmitter on the bench before installation using a Communication Device, AMS Device Manager, or any *WirelessHART* Communicator ensures that all network settings are working correctly.

When using a Communication Device, any configuration changes made must be sent to the transmitter by using the **Send** key (F2). AMS Device Manager configuration changes are implemented when the **Apply** button is selected.

2.2.1 AMS Device Manager

AMS Device Manager is capable of connecting to devices either directly, using a HART[®] modem, or wirelessly via the Smart Wireless Gateway. When configuring the device, double click the device icon or right click and select **Configure**.

2.2.2 Connection diagrams

Bench hook-up

Connect the bench equipment as shown in [Figure 2-1](#), and turn on the Communication Device by pressing the **ON/OFF** key or log into AMS Device Manager. The Communication Device or AMS Device Manager will search for a HART-compatible device and indicate when the connection is made. If the Communication Device or AMS Device Manager fail to connect, it indicates that no device was found. If this occurs, refer to [Troubleshooting](#).

Field hook-up

[Figure 2-1](#) illustrates the wiring for a field hook-up with a Communication Device or AMS Device Manager. The Communication Device or AMS Device Manager may be connected at system output on the transmitter power module.

Figure 2-1: Communication Device Connection

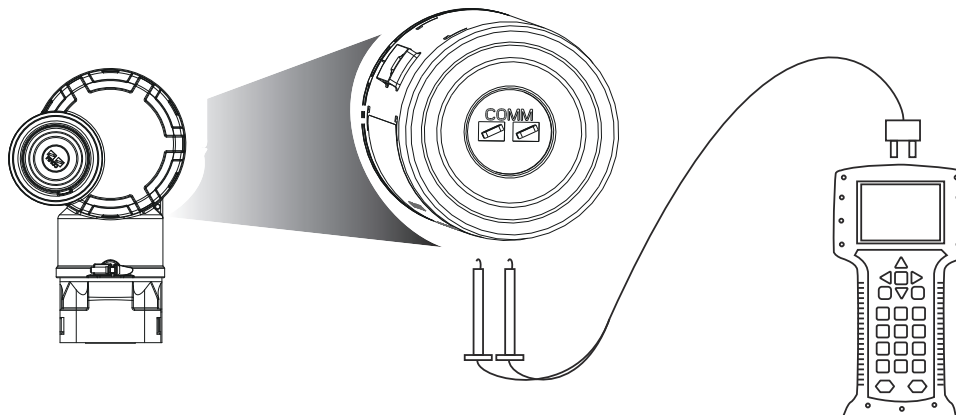

For HART Communication, a Rosemount 3051 WirelessHART DD is required.

2.3 Basic setup

2.3.1 Set device tag

Fast Keys	2, 1, 1, 1
-----------	------------

The tag is used to identify the device. You can use an 8–32 character tag.

Procedure

1. From the **Home** screen, select **2: Configure**.
2. Select **1: Guided Setup**.
3. Select **1: Basic Setup**.
4. Select **1: Tagging**.

2.3.2 Join device to network

Fast Keys	2, 1, 3
-----------	---------

In order to communicate with the Smart Wireless Gateway, and ultimately the host system, the transmitter must be configured to communicate over the wireless network. This step is the wireless equivalent of connecting wires from a transmitter to the host system.

Procedure

1. From the **Home** screen, select **2: Configure**.
2. Select **1: Guided Setup**.
3. Select **3: Join Device to Network**.

Example

Using a Communication Device or AMS Device Manager, enter the Network ID and Join Key so that they match the Network ID and Join Key of the Smart Wireless Gateway and other devices in the network. If the Network ID and Join Key are not identical to those set in the Gateway, the transmitter will not communicate with the network. The Network ID and Join

Key may be obtained from the Smart Wireless Gateway on the **Setup** → **Network** → **Settings** page on the web server.

2.3.3 Configure update rate

Fast Keys	2, 1, 4
-----------	---------

The update rate is the frequency at which a new measurement is taken and transmitted over the wireless network. This by default is one minute. This may be changed at commissioning, or at any time via AMS Device Manager. The update rate is user selectable from one second to 60 minutes.

Procedure

1. From the **Home** screen, select **2: Configure**.
2. Select **1: Guided Setup**.
3. Select **4: Configure Update Rate**.

2.3.4 Set process variable units

Fast Keys	2, 2, 2, 4
-----------	------------

The **PV Unit** command sets the process variable units to allow you to monitor your process using the appropriate units of measure.

To select a unit of measure for the PV:

Procedure

1. From the **Home** screen, select **2: Configure**.
2. Select **2: Manual Setup**.
3. Select **2: Pressure**.
4. Select **1: Unit** to select from the following engineering units:

- | | | | |
|-------------------------------|-------------------------------|----------------|----------------------|
| • inH ₂ O at 4 °C | • mmH ₂ O at 68 °F | • mmHg | • Mpa |
| • inH ₂ O at 60 °F | • cmH ₂ O at 4 °C | • Psi | • Bar |
| • inH ₂ O at 68 °F | • mH ₂ O at 4 °C | • Atm | • Mbar |
| • ftH ₂ O at 4 °C | • inHg at 0 °C | • Torr | • g/cm ² |
| • ftH ₂ O at 60 °F | • mmHg at 0 °C | • Pascals | • kg/cm ² |
| • ftH ₂ O at 68 °F | • cmHg at 0 °C | • hectoPascals | • kg/m ² |
| • mmH ₂ O at 4 °C | • mHg at 0 °C | • Kilopascals | |

2.3.5 Remove power module

Procedure

- After the sensor and network have been configured, remove the power module and replace the housing cover. The power module should be inserted only when the device is ready to be commissioned.

- Use caution when handling the power module. The Power Module may be damaged if dropped from heights in excess of 6.10 m (20 ft).

2.4 Configure for pressure

2.4.1 Re-mapping device variables

The re-mapping function allows the transmitter primary, secondary, tertiary, and quaternary variables (PV, SV, TV, and QV) to be configured in one of two configurations. The user may select either the option of classic mapping or scaled variable mapping, see [Table 2-1](#) for what is mapped to each variable. All variables can be remapped with a Communication Device or AMS Device Manager.

Table 2-1: Variable Mapping

Variable	Classic mapping	Scaled variable mapping
PV	Pressure	Scaled variable
SV	Sensor temperature	Pressure
TV	Electronics temperature	Sensor temperature
QV	Supply voltage	Supply voltage

Note

The variable assigned to the primary variable drives the output. This value can be selected as pressure or scaled variable.

Re-mapping using a Communication Device

From the **HOME** screen, enter the Fast Key sequence.

Fast Keys	2, 1, 1, 4
-----------	------------

Re-mapping using AMS Device Manager

Procedure

1. Right click on the device and select **Configure**.
2. Select **Manual Setup** and click on the HART® tab.
3. Assign primary, secondary, tertiary and quaternary variables under **Variable Mapping**.
4. Select **Send**.
5. Carefully read the warning and select **Yes** if it is safe to apply the changes.

2.4.2 Set range points

From the **HOME** screen, enter the Fast Key sequence.

Fast Keys	2, 1, 1, 5
-----------	------------

The range values command sets the lower and upper range values used for the percent of range measurement.

Note

Transmitters are shipped from Emerson fully calibrated per request or by the factory default of full scale (span = upper range limit).

Procedure

1. From the **Home** screen, select **2: Configure**.
2. Select **1: Guided Setup**.
3. Select **1: Basic Setup**.
4. Select **5: Range Values**.

2.4.3 Set transmitter percent of range (transfer function)

The Rosemount 3051 Wireless Transmitter has two transfer functions for pressure applications: Linear and Square Root. As shown in [Figure 2-2](#), activating the square root options the transmitter analog output proportional to flow.

However, for DP Flow and DP Level applications it is recommended to use scaled variable. Refer to [Diagnostics and service](#) for setup instructions.

From 0 to 0.6 percent of the ranged pressure input, the slope of the curve is unity ($y = x$). This allows accurate calibration near zero. Greater slopes would cause large changes in output (for small changes at input). From 0.6 percent to 0.8 percent, curve slope equals 42 ($y = 42x$) to achieve continuous transition from linear to square root at the transition point.

Setting transmitter output with a Communication Device

From the **HOME** screen, enter the Fast Key sequence.

Fast Keys	2, 2, 2, 6
-----------	------------

Setting transmitter output with AMS Device Manager

Procedure

1. Right click on the device and select **Configure**.
2. Select **Manual Setup** and select output type from Transfer Function and select **Send**.
3. Carefully read the warning and select **Yes** if it is safe to apply the changes.

Figure 2-2: Square Root Output Transition Point

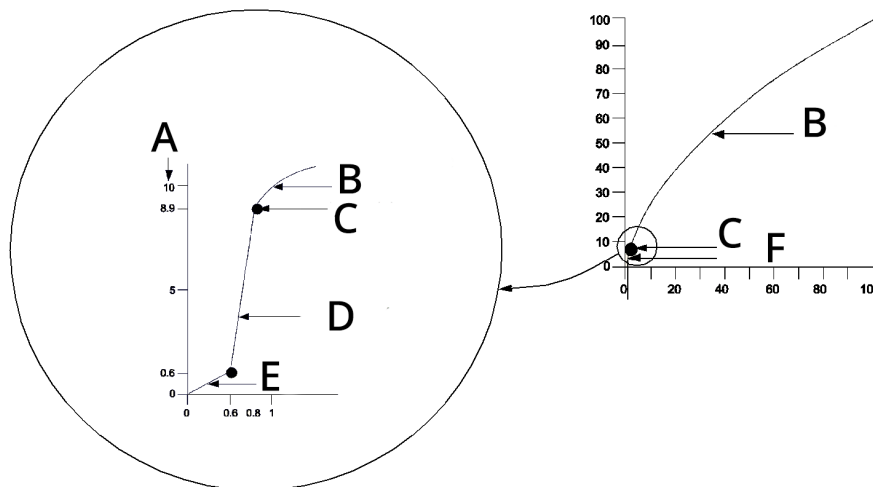

- A. Full scale flow (%)
- B. Square root curve
- C. Transition point
- D. Slope = 42
- E. Slope = 1
- F. Linear section

2.5 Configure for level and flow

2.5.1 Configuring scaled variable

The scaled variable configuration allows the user to create a relationship/conversion between the pressure units and user-defined/custom units. There are two use cases for scaled variable. The first use case is to allow custom units to be displayed on the transmitter's LCD display. The second use case is to allow custom units to drive the transmitter's PV output.

If the user desires custom units to drive the PV output, Scaled Variable must be re-mapped as the primary variable. Refer to [Re-mapping device variables](#).

The Scaled Variable configuration defines the following items:

- Scaled variable units - custom units to be displayed.
- Scaled data options - defines the transfer function for the application.
 - Linear
 - Square root
- Pressure value position 1 - lower known value point with consideration of linear offset.
- Scaled variable value position 1 - custom unit equivalent to the lower known value point.
- Pressure value position 2 - upper known value point.

- Scaled variable value position 2 - custom unit equivalent to the upper known value point.
- Linear offset - the value required to zero out pressures affecting the desired pressure reading.
- Low flow cutoff - point at which output is driven to zero to prevent problems caused by process noise. It is highly recommended to use the low flow cutoff function in order to have a stable output and avoid problems due to process noise at a low flow or no flow condition. A low flow cutoff value that is practical for the flow element in the application should be entered.

Configuring Scaled Variable using a Communication Device

Procedure

1. From the **HOME** screen, enter the Fast Key sequence.

Device Dashboard Fast Keys	2, 1, 7, 1
----------------------------	------------

2. Follow the screen prompts to configure Scaled Variable.
 - a) When configuring for level, select **Linear** under Select Scaled data options.
 - b) When configuring for flow, select **Square Root** under Select Scaled data options.

Configuring LCD display with AMS Device Manager

Procedure

1. Right click on the device and select **Configure**.
2. Click **Manual Setup**, select the **Display** tab.
3. Select desired display options and select **Send**.

2.5.2 Re-mapping device variables

The re-mapping function allows the transmitter primary, secondary, tertiary, and quaternary variables (PV, SV, TV, and QV) to be configured in one of two configurations. The user may select either the option of classic mapping or scaled variable mapping, see [Table 2-2](#) for what is mapped to each variable. All variables can be remapped with a Communication Device or AMS Device Manager.

Table 2-2: Variable Mapping

Variable	Classic mapping	Scaled variable mapping
PV	Pressure	Scaled variable
SV	Sensor temperature	Pressure
TV	Electronics temperature	Sensor temperature
QV	Supply voltage	Supply voltage

Note

The variable assigned to the primary variable drives the output. This value can be selected as pressure or scaled variable.

Re-mapping using a Communication Device

Procedure

- From the **HOME** screen, enter the Fast Key sequence.

Device Dashboard Fast Keys	2, 1, 1, 4
----------------------------	------------

Re-mapping using AMS Device Manager

Procedure

- Right click on the device and select **Configure**.
- Select **Manual Setup** and select on the HART® tab.
- Assign primary, secondary, tertiary and quaternary variables under **Variable Mapping**.
- Select **Send**.
- Carefully read the warning and select **Yes** if it is safe to apply the changes.

2.5.3 Set range points

From the **HOME** screen, enter the Fast Key sequence

Device Dashboard Fast Keys	2, 1, 1, 5
----------------------------	------------

The Range Values command sets the lower and upper range values used for the percent of range measurement.

Note

Transmitters are shipped from Emerson fully calibrated per request or by the factory default of full scale (span = upper range limit).

Procedure

- From the **Home** screen, select **2: Configure**.
- Select **1: Guided Setup**.
- Select **1: Basic Setup**.
- Select **5: Range Values**.

2.6 Review configuration data

The following is a list of factory default configurations that can be viewed by using the Communication Device or AMS Device Manager. Follow the steps below to review the transmitter configuration information.

Note

Information and procedures in this section that make use of Communication Device Fast Key sequences and AMS Device Manager assume that the transmitter and communication equipment are connected, powered, and operating correctly.

2.6.1 Review pressure information

Device Dashboard Fast Keys	2, 2, 2
----------------------------	---------

To view pressure information:

Procedure

1. From the **Home** screen, select **2: Configure**.
2. Select **2: Manual Setup**.
3. Select **2: Pressure**.
4. Select from the corresponding number to view each field:
 - a. Set range points
 - b. Set range points manually
 - c. Sensor limits
 - d. Units
 - e. Damping
 - f. Transfer function

2.6.2 Review device information

Devise Dashboard Fast Keys	2, 2, 8
----------------------------	---------

To view device information:

Procedure

1. From the **Home** screen, select **2: Configure**.
2. Select **2: Manual Setup**.
3. Select **8: Device Information**.
4. Select from the corresponding number to view each field:
 - a. Identification
 - b. Model Numbers
 - c. Flange Information
 - d. Remote seal Information
 - e. Serial number

2.6.3 Review radio information

Devise Dashboard Fast Keys	1, 9, 3
----------------------------	---------

To view radio information:

Procedure

1. From the **Home** screen, select **1: Overview**.
2. Select **9: Device Information**.
3. Select **3: Radio**.
4. Select from the corresponding number to view each field
 - a. Manufacturer

- b. Device type
- c. Device revision
- d. Software revision
- e. Hardware revision
- f. Transmit power level
- g. Minimum update rate

2.6.4 Review operating parameters

Devise Dashboard Fast Keys	3, 2
----------------------------	------

The pressure output value in both engineering units and percent of range will reflect the applied pressure even when the applied pressure is outside of the configured range as long as the applied pressure is between the upper and lower range limit of the transmitter. For example, if a Range 2 3051T (LRL = 0 psi, URL = 150 psi) is ranged from 0 to 100 psi, an applied pressure of 150 psi will return a percent of range output of 150% and an engineering output of 150 psi.

To view the **Operating Parameters** menu:

Procedure

1. From the **Home** screen, select **3: Service Tools**.
2. Select **2: Variables**.

The **Operating Parameters** menu displays the following information pertaining to the device:

- a. Process
 - Pressure
 - Percent of range
 - Last update time
 - Enter Fast Update Mode
- b. Device
 - Sensor temperature
 - Supply voltage

2.7 Configuring the LCD display

The LCD display configuration command allows customization of the LCD display to suit application requirements. The LCD display will alternate between the selected items.

- Pressure units
- % of range
- Scaled variable
- Sensor temperature
- Supply voltage

In the following instructions, the LCD display can also be configured to display configuration information during the device startup. Select Review Parameters at Startup to enable or disable this functionality.

2.7.1 Configuring LCD display with a Communication Device

From the **HOME** screen, enter the Fast Key sequence

Device Dashboard Fast Keys	2, 2, 4
----------------------------	---------

2.7.2 Configuring LCD display with AMS Device Manager

Procedure

1. Right click on the device and select **Configure**.
2. Click **Manual Setup**, select the **Display** tab.
3. Select desired display options and select **Send**.

2.8 Detailed transmitter setup

2.8.1 Configure process alerts

Device Dashboard Fast Keys	2, 1, 6
----------------------------	---------

Process alerts allow the transmitter to indicate when the configured data point is exceeded. Process alerts can be set for pressure, temperature, or both. An alert will be displayed on a Communication Device, AMS Device Manager status screen or in the error section of the LCD display. The alert will reset once the value returns within range.

Note

HI alert value must be higher than the LO alert value. Both alert values must be within the pressure or temperature sensor limits.

Figure 2-3: Example 1: Rising Alert

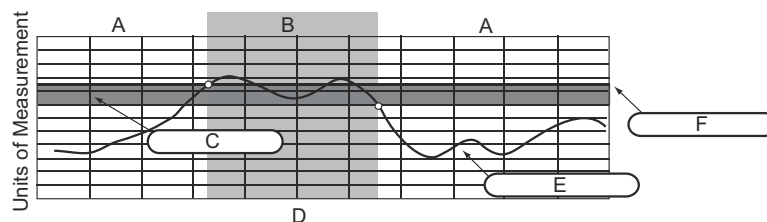

- A. Alert "OFF"
- B. Alert "ON"
- C. Deadband
- D. Time
- E. Assigned Value
- F. Alert Set Point

Figure 2-4: Example 2: Falling Alert

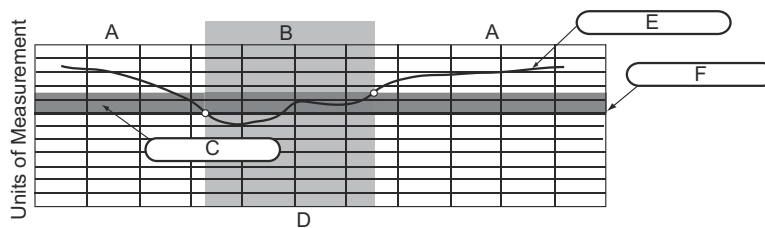

- A. Alert "OFF"
- B. Alert "ON"
- C. Deadband
- D. Time
- E. Assigned Value
- F. Alert Set Point

To configure the process alerts, perform the following procedure:

Procedure

1. From the **Home** screen, select **2: Configure**.
2. Select **1: Guided Setup**.
3. Select **6: Configure Process Alerts** and follow the on-screen instructions to complete configure of process alarms.

2.8.2

Damping

The damping command introduces a delay in processing which increases the response time of the transmitter; smoothing variations in output readings caused by rapid input changes. In the Rosemount 3051 Wireless, damping only takes effect when the device is placed in high power refresh mode and during calibration. In normal power mode, the effective damping is zero. Note that when the device is in high power refresh mode, battery power will be depleted rapidly. Determine the appropriate damp setting based on the necessary response time, signal stability, and other requirements of the loop dynamics of your system. The damping value of your device is user selectable from zero to 60 seconds.

Damping with a Communication Device

Procedure

1. From the **HOME** screen, enter the Fast Key sequence.

Device Dashboard Fast Keys	2, 2, 2, 5
----------------------------	------------

2. Enter desired damping value and select **Apply**.

Damping with AMS Device Manager

Procedure

1. Right click on the device and select **Configure**.
2. Select **Manual Setup**.
3. Within the Pressure Setup box, enter desired damping value and click **Send**.

- Carefully read the warning and select **Yes** if it is safe to apply the changes.

2.8.3 Write protect

The Rosemount 3051 Wireless has a software write protect security feature.

Enabling write protect with a Communication Device

Procedure

- From the **HOME** screen, enter the Fast Key sequence.

Device Dashboard Fast Keys	2, 2, 6, 3
----------------------------	------------

- Select Write Protect to enable.

Enabling write protect with AMS Device Manager

Procedure

- Right click on device and select **Configure**.
- Select **Manual Setup**.
- Select the tab labeled **Device Information**.
- Select **Write Protect** to enable this feature.

2.9 Diagnostics and service

Diagnostics and service functions listed below are primarily for use after field installation. The Transmitter Test feature is designed to verify the transmitter is operating properly, and can be performed either on the bench or in the field.

2.9.1 Master reset

The master reset function will reset the device electronics. To perform a master reset:

Performing master reset using a Communication Device

Procedure

- From the **HOME** screen, enter the Fast Key sequence.

Device Dashboard Fast Keys	3, 5, 1, 2, 1
----------------------------	---------------

Performing master reset using AMS Device Manager

Procedure

- From the **Home** screen, select **3: Service Tools**.
- Select **5: Maintenance**.
- Select **1: Calibration**.
- Select **2: Factory Calibration**.
- Select **1: Restore** to restore to factory presets.

2.9.2 Join status

Viewing join status using a Communication Device

Procedure

- From the **HOME** screen, enter the Fast Key sequence.

Device Dashboard Fast Keys	3, 4, 1
----------------------------	---------

Viewing join status using AMS Device Manager

To view the join status of the device, perform the following procedure:

Procedure

1. From the **Home** screen, select **3: Service Tools**.
2. Select **4: Communications**.
3. Select **1: Join Status**.

Wireless devices join the secure network through a four step process:

- Step 1. Network Found
- Step 2. Network Security Clearance Granted
- Step 3. Network Bandwidth Allocated
- Step 4. Network Join Complete

2.9.3 Number of available neighbors

Viewing number of available neighbors using a Communicator device

Procedure

- From the **HOME** screen, enter the Fast Key sequence.

Device Dashboard Fast Keys	3, 4, 3
----------------------------	---------

Viewing number of available neighbors using AMS Device Manager

In a self-organizing network, the more neighbors a device has, the more robust the network will be. To view the number of available neighbors for the wireless device, perform the following procedure:

Procedure

1. From the **Home** screen, select **3: Service Tools**.
2. Select **4: Routine Maintenance**.
3. Select **3: Number of Available Neighbors**.

2.10 Advanced functions for HART Protocol

2.10.1 Saving, recalling, and cloning configuration data

Device Dashboard Fast Keys	left arrow, 1, 2
----------------------------	------------------

Use the cloning feature of the Communication Device or the AMS **User Configuration** feature to configure several Rosemount 3051 Wireless similarly. Cloning involves configuring a transmitter, saving the configuration data, then sending a copy of the data to a separate transmitter. Several possible procedures exist when saving, recalling, and cloning configuration data. For complete instructions refer to the Communication Device or AMS Books Online. One common method is as follows:

Communication Device

Procedure

1. Completely configure the first transmitter.
2. Save the configuration data:
 - a) Select **F2 Save** from the Communication Device **Home/Online** screen.
 - b) Ensure the location to which the data will be saved is set to Module. If it is not, select **1: Location** to set the save location to module.
 - c) Select **2: Name**, to name the configuration data. The default is the transmitter tag number.
 - d) Ensure the data type is set to standard. If the data type is not standard, select **3: Data Type** to set the data type to standard.
 - e) Select **F2 Save**.
3. Connect and power the receiving transmitter and Communication Device.
4. Select the back arrow from the **Home/Online** screen. The Communication Device menu appears.
5. Select **1: Offline, 2: Saved Configuration, 1: Module Contents** to reach the **Module Contents** menu.
6. Use the **down arrow** to scroll through the list of configurations in the memory module, and use the **right arrow** to select and retrieve the required configuration.
7. Select **1: Edit**.
8. Select **1: Mark All**.
9. Select **F2 Save**.
10. Use the **down arrow** to scroll through the list of configurations in the memory module, and use the **right arrow** to select the configuration again.
11. Select **3: Send** to download the configuration to the transmitter.
12. Select **OK** after the control loop is set to manual.
13. After the configuration has been sent, select **OK**.

When finished, the Communication Device informs you of the status. Repeat steps [Step 3](#) through [Step 13](#) to configure another transmitter.

Note

The transmitter receiving cloned data must have the same software version (or later) as the original transmitter.

AMS Device Manager creating a reusable copy

To create a reusable copy of a configuration perform the following procedure:

Procedure

1. Completely configure the first transmitter.
2. Select **View** → **User Configuration View** → **Menu bar** (or click the toolbar button).
3. In the **User Configuration** window, right click and select **New** from the context menu.
4. In the **New** window, select a device from the list of templates shown, and select **OK**.
5. The template is copied into the **User Configurations** window, with the tag name highlighted; rename it as appropriate and press **Enter**.

Note

A device icon can also be copied by dragging and dropping a device template or any other device icon from AMS Explorer or Device Connection View into the **User Configurations** window.

The **Compare Configurations** window appears, showing the Current values of the copied device on one side and mostly blank fields on the other (**User Configuration**) side.

6. Transfer values from the current configuration to the user configuration as appropriate or enter values by typing them into the available fields.
7. Select **Apply** to apply the values, or select **OK** to apply the values and close the window.

AMS Device Manager applying a user configuration

Any amount of user configurations can be created for the application. They can also be saved, and applied to connected devices or to devices in the Device List or Plant Database.

To apply a user configuration perform the following procedure:

Procedure

1. Select the desired user configuration in the **User Configurations** window.
2. Drag the icon onto a like device in AMS Explorer or Device Connection View. The **Compare Configurations** window opens, showing the parameters of the target device on one side and the parameters of the user configuration on the other.
3. Transfer parameters from the user configuration to the target device as desired, Select **OK** to apply the configuration and close the window.

3 Installation

3.1 Overview

The information in this section covers installation considerations. A Quick Start Guide is shipped with every transmitter to describe basic installation and startup procedures. Dimensional drawings for each Rosemount 3051 Wireless variation and mounting configuration are included in [Product Data Sheet](#).

Note

For transmitter disassembly refer to [Removing from service](#).

3.2 Installation considerations

Measurement performance depends upon proper installation of the transmitter and impulse piping. Mount the transmitter close to the process and use a minimum of piping to achieve best performance. Also, consider the need for easy access, personnel safety, practical field calibration, and a suitable transmitter environment. Install the transmitter to minimize vibration, shock, and temperature fluctuation.

3.2.1 Wireless considerations

Power up sequence

The power module should not be installed on any wireless device until the Smart Wireless Gateway is installed and functioning properly. This transmitter uses the green power module (order model number 701PGNKF). Wireless devices should also be powered up in order of proximity from the Gateway, beginning with the closest. This will result in a simpler and faster network installation. Enable Active Advertising on the Gateway to ensure new devices join the network faster. For more information, see the [Emerson Wireless 1410S Gateway and 781S Smart Antenna](#).

Internal antenna position

The internal antenna is designed for multiple mounting orientations. The transmitter should be mounted according to measurement best practices for your pressure measurement application. The antenna should be approximately 3 ft. (1 m) from any large structure or building to allow clear communication to other devices.

Communication Device connections

In order for the Communication Device to interface with the Rosemount 3051 Wireless, the power module must be connected. Refer to [Figure 3-1](#) for a diagram on how to connect the Communication Device.

Figure 3-1: Communication Device Connections

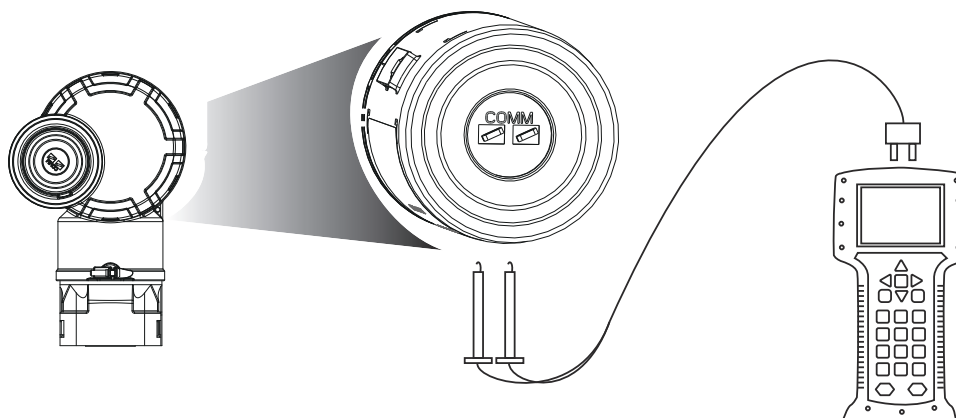

3.2.2 Mechanical considerations

Steam service

For steam service or for applications with process temperatures greater than the limits of the transmitter, do not blow down impulse piping through the transmitter. Flush lines with the blocking valves closed and refill lines with water before resuming measurement. Refer to [Figure 3-11](#) for correct mounting orientation.

Side mounted

When the transmitter is mounted on its side, position the coplanar flange to ensure proper venting or draining. Mount the flange as shown in [Figure 3-11](#), keeping drain/vent connections on the bottom for gas service and on the top for liquid service.

3.2.3 Environmental considerations

Best practice is to mount the transmitter in an environment that has minimal ambient temperature change. The transmitter electronics temperature operating limits are -40 to 185 °F (-40 to 85 °C). Refer to [Product Data Sheet](#) that lists the sensing element operating limits. Mount the transmitter so that it is not susceptible to vibration and mechanical shock and does not have external contact with corrosive materials.

Figure 3-2: Installation Flowchart

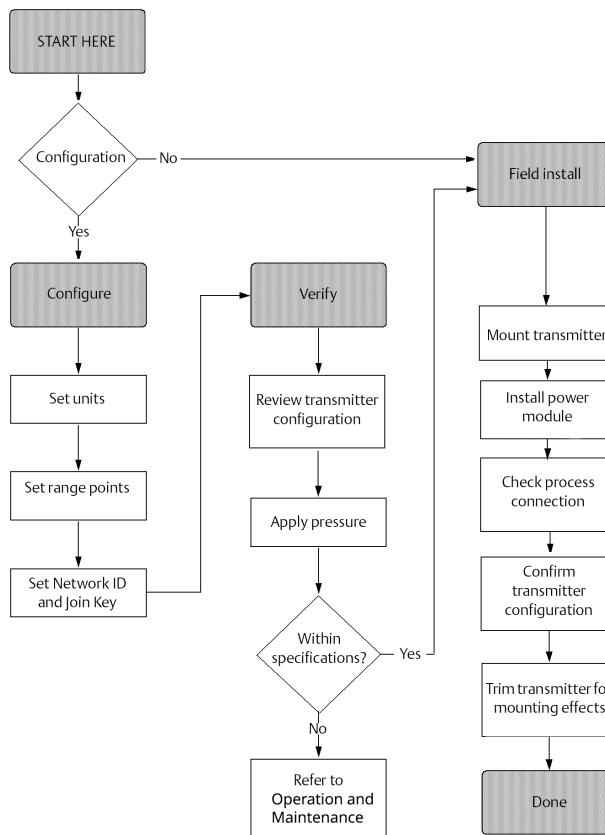

3.2.4 Draft range considerations

For the Rosemount 3051CD0 Draft Range Pressure Transmitter, it is best to mount the transmitter with the isolators parallel to the ground. See [Figure 3-3](#) for a draft range installation example on a Rosemount 304 Manifold. Installing the transmitter in this way reduces oil head effect.

Tilting of the transmitter may cause a zero shift in the transmitter output, but can be eliminated by performing a trim procedure.

Figure 3-3: Draft Range Installation

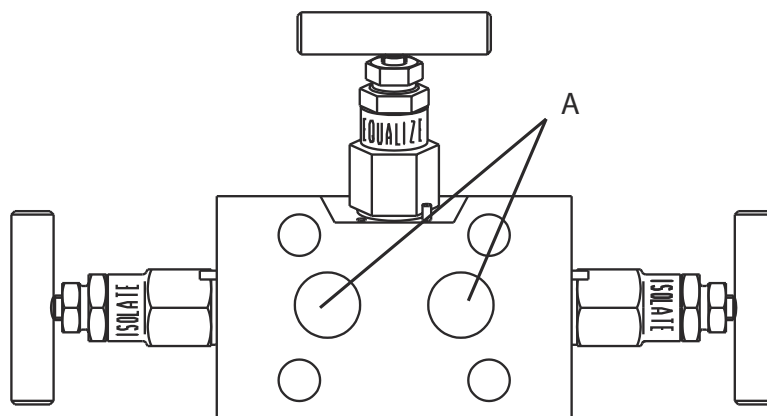

A. Isolators

Reducing process noise

Rosemount 3051CD0 Draft Transmitters are sensitive to small pressure changes. Increasing the damping will decrease output noise, but will further reduce response time. In gage applications, it is important to minimize pressure fluctuations to the low side isolator.

Output damping

The damping command introduces a delay in processing which increases the response time of the transmitter; smoothing variations in output readings caused by rapid input changes. In the Rosemount 3051 Wireless, damping only takes effect when the device is placed in high power refresh mode and during calibration. In normal power mode, the effective damping is zero. Note that when the device is in high power refresh mode, battery power will be depleted rapidly. Determine the appropriate damp setting based on the necessary response time, signal stability, and other requirements of the loop dynamics of your system. The damping value of your device is user selectable from zero to 60 seconds.

Reference side filtering

In gage applications it is important to minimize fluctuations in atmospheric pressure to which the low side isolator is exposed.

One method of reducing fluctuations in atmospheric pressure is to attach a length of tubing to the reference side of the transmitter to act as a pressure buffer.

3.3 Installation procedures

3.3.1 Mounting the transmitter

For dimensional drawing information refer to [Product Data Sheet](#).

Process flange orientation

Mount the process flanges with sufficient clearance for process connections. For safety reasons, place the drain/vent valves so the process fluid is directed away from possible

human contact when the vents are used. In addition, consider the need for a testing or calibration input.

Note

Most transmitters are calibrated in the horizontal position. Mounting the transmitter in any other position will shift the zero point to the equivalent amount of liquid head pressure caused by the varied mounting position. To reset zero point, refer to [Sensor trim](#).

Housing rotation

The electronics housing can be rotated up to 180 degrees in either direction to improve field access, or to better view the optional LCD display. To rotate the housing, perform the following procedure:

Procedure

1. Loosen the housing rotation set screw using a 5/64-in. hex wrench.
2. Turn the housing left or right up to 180° from its original position.

Note

Over rotating will damage the transmitter.

3. Retighten the housing rotation set screw.
-

Figure 3-4: Housing Rotation

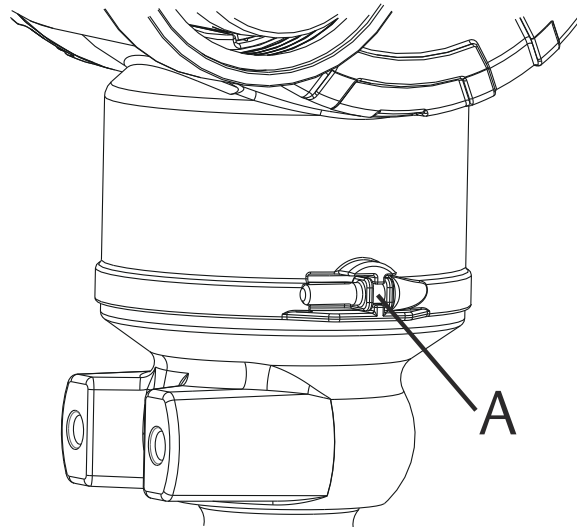

A. Housing rotation set screw (5/64-in.)

Terminal side of electronics housing

Mount the transmitter so the power module side is accessible. Clearance of 3.5-in. (89 mm) is required for cover and power module removal.

Circuit side of electronics housing

Provide 1.75-in. (45 mm) of clearance for units without an LCD display. Three inches of clearance is required for cover removal if a meter is installed.

Environmental seal for housing

Thread sealing (PTFE) tape or paste on male threads of conduit is required to provide a water/dust tight conduit seal and meets requirements of NEMA Type 4X, IP66, and IP68. Consult factory if other Ingress Protection ratings are required.

For M20 threads, install conduit plugs to full thread engagement or until mechanical resistance is met.

Always ensure a proper seal by installing the electronics housing cover(s) so that polymer contacts polymer (i.e. no O-ring visible). Use Rosemount O-rings.

Mounting brackets

Rosemount 3051 Transmitters may be panel-mounted or pipe-mounted via an optional mounting bracket. Refer to [Table 3-1](#) for the complete offering and see [Figure 3-5](#) for dimensional and mounting configuration information.

Table 3-1: Rosemount 3051 Mounting Brackets

Option code	Process connections			Mounting			Materials			
	Coplanar	In-line	Traditional	Pipe mount	Panel mount	Flat panel mount	CS bracket	SST bracket	CS bolts	SST bolts
B4	✓	✓	N/A	✓	✓	✓	N/A	✓	N/A	✓
B1	N/A	N/A	✓	✓	N/A	N/A	✓	N/A	✓	N/A
B2	N/A	N/A	✓	N/A	✓	N/A	✓	N/A	✓	N/A
B3	N/A	N/A	✓	N/A	N/A	✓	✓	N/A	✓	N/A
B7	N/A	N/A	✓	✓	N/A	N/A	✓	N/A	N/A	✓
B8	N/A	N/A	✓	N/A	✓	N/A	✓	N/A	N/A	✓
B9	N/A	N/A	✓	N/A	N/A	✓	✓	N/A	N/A	✓
BA	N/A	N/A	✓	✓	N/A	N/A	N/A	✓	N/A	✓
BC	N/A	N/A	✓	N/A	N/A	✓	N/A	✓	N/A	✓

Figure 3-5: Mounting Bracket Option Code B4

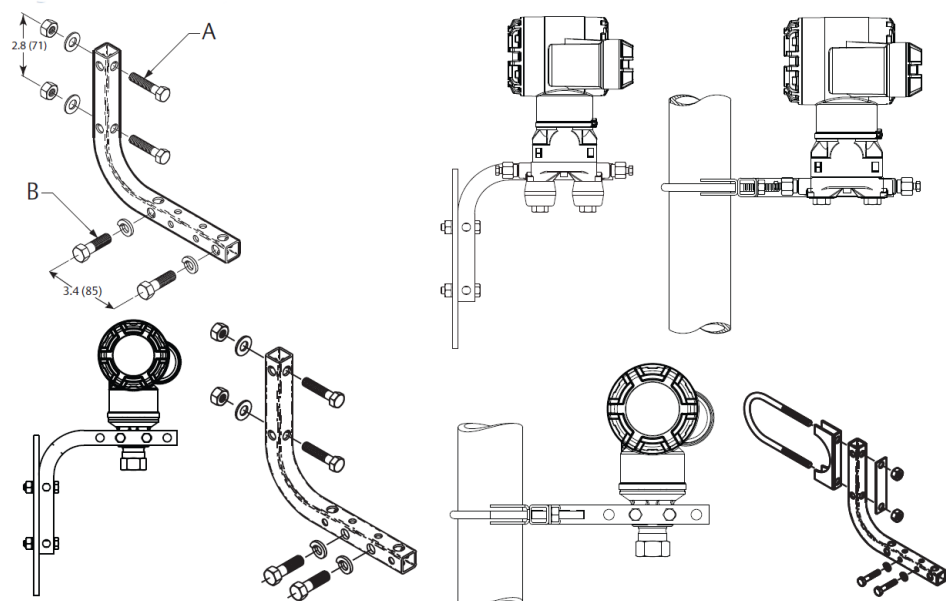

- A. 5/16 X 1 1/2 bolts for panel mounting (not supplied)
- B. 3/8-16 X 1 1/4 bolts for mounting to transmitter

Dimensions are in inches (millimeters).

Figure 3-6: Mounting Bracket Option Codes B1, B7, and BA

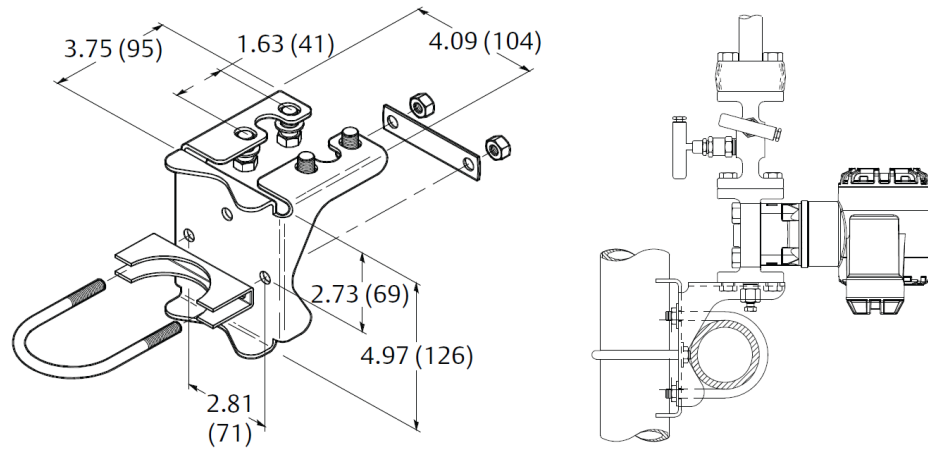

Dimensions are in inches (millimeters).

Figure 3-7: Panel Mounting Bracket Option Codes B2 and B8

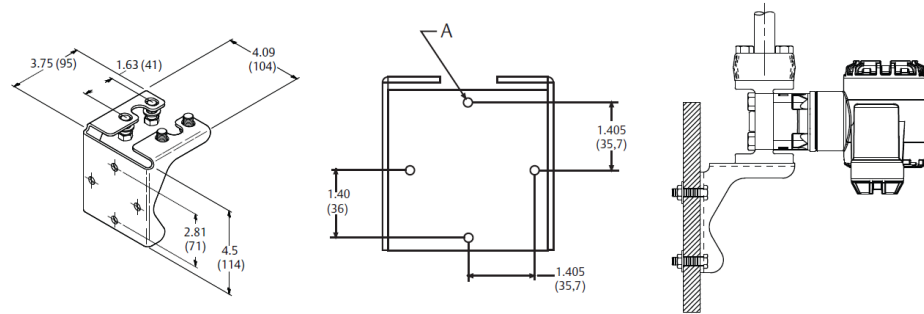

A. Mounting holes 0.375 in. diameter (10)

Dimensions are in inches (millimeters).

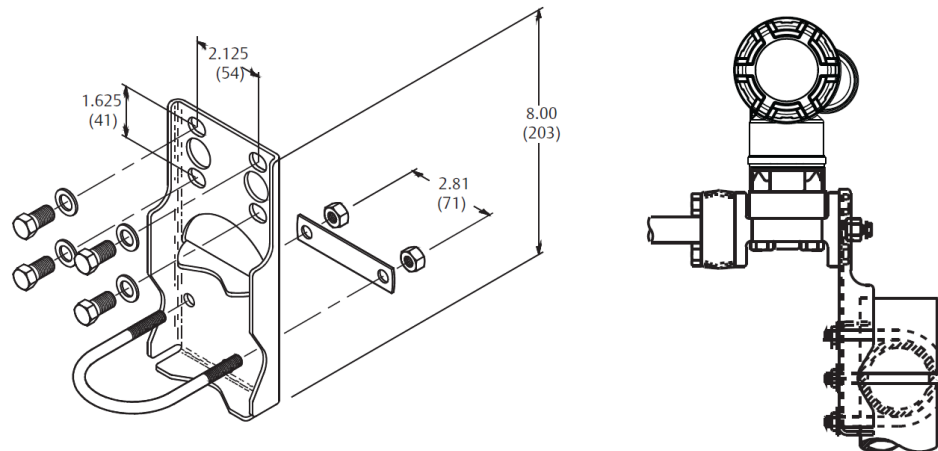

Figure 3-8: Flat Mounting Bracket Option Codes B3 and BC



Dimensions are in inches (millimeters).

Flange bolts

The Rosemount 3051 Wireless can be shipped with a coplanar flange or a traditional flange installed with four 1.75-in. flange bolts. Mounting bolts and bolting configurations for the coplanar and traditional flanges can be found in [Figure 3-9](#). Stainless steel bolts supplied by Emerson are coated with a lubricant to ease installation. Carbon steel bolts do not require lubrication. No additional lubricant should be applied when installing either type of bolt. Bolts supplied by Emerson are identified by their head markings:

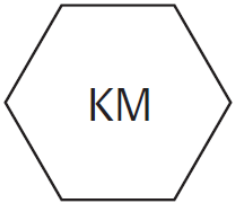
	Carbon Steel (CS) head markings
	Stainless Steel (SST) head markings
	Alloy K-500 head marking

A. The letter in the F593_ head marking may be any letter between A and M.

Bolt installation

⚠ CAUTION

Only use bolts supplied with the Rosemount 3051 or sold by Emerson as spare parts. When installing the transmitter to one of the optional mounting brackets, torque the bolts to 125 in-lb. (0.9 N-m). Use the following bolt installation procedure:

Procedure

1. Finger-tighten the bolts.
2. Torque the bolts to the initial torque value using a crossing pattern.
3. Torque the bolts to the final torque value using the same crossing pattern.

Example

Torque values for the flange and manifold adapter bolts are as follows:

Table 3-2: Bolt Installation Torque Values

Bolt material	Initial torque value	Final torque value
CS-ASTM-A445 Standard	300 in-lb (34 N-m)	650 in-lb (73 N-m)
316 SST—Option L4	150 in-lb (17 N-m)	300 in-lb (34 N-m)
ASTM-A-193-B7M—Option L5	300 in-lb (34 N-m)	650 in-lb (73 N-m)
Alloy K-500—Option L6	300 in-lb (34 N-m)	650 in-lb (73 N-m)
ASTM-A-453-660—Option L7	150 in-lb (17 N-m)	300 in-lb (34 N-m)
ASTM-A-193-B8M—Option L8	150 in-lb (17 N-m)	300 in-lb (34 N-m)

Figure 3-9: Traditional Flange Bolt Configurations

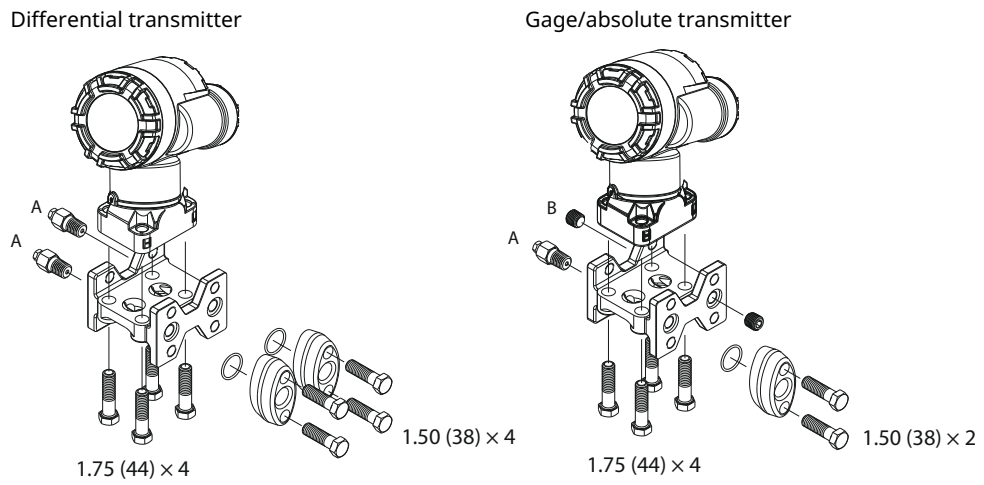

- A. Drain/vent
- B. Vented fitting

Dimensions are in inches (millimeters).

Figure 3-10: Mounting Bolts And Bolt Configurations For Coplanar Flange

Transmitter with flange bolts

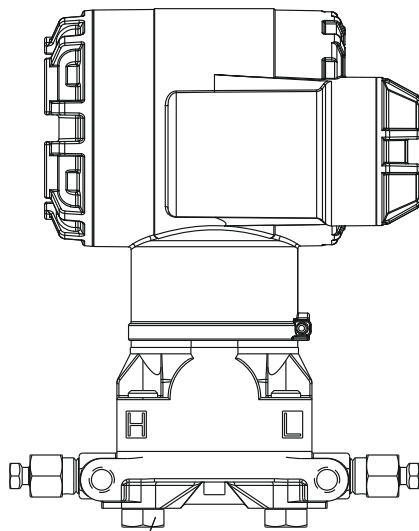

1.75 (44) × 4

Transmitter with flange adapters and flange/
adapter bolts

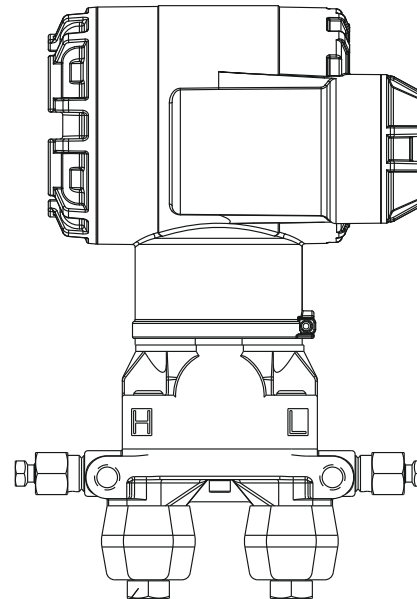

2.88 (73) × 4

Dimensions are in inches (millimeters).

Description	Qty	Size in. (mm)
Differential pressure		
Flange bolts	4	1.75 (44)
Flange/adapter bolts	4	2.88 (73)
Gage/absolute pressure ⁽¹⁾		
Flange bolts	4	1.75 (44)
Flange/adapter bolts	2	2.88 (73)

(1) Rosemount 3051T transmitters are direct mount and do not require bolts for process connection.

3.3.2 Impulse piping

Mounting requirements

Impulse piping configurations depend on specific measurement conditions. Refer to [Figure 3-11](#) for examples of the following mounting configurations:

Liquid measurement

- Place taps to the side of the line to prevent sediment deposits on the transmitter's process isolators.
- Mount the transmitter beside or below the taps so gases can vent into the process line.
- Mount drain/vent valve upward to allow gases to vent.

Gas measurement

- Place taps in the top or side of the line.
- Mount the transmitter beside or above the taps so liquid will drain into the process line.

Steam measurement

- Place taps to the side of the line.
- Mount the transmitter below the taps to ensure that the impulse piping will stay filled with condensate.
- In steam service above 250 °F (121 °C), fill impulse lines with water to prevent steam from contacting the transmitter directly and to ensure accurate measurement start-up.

NOTICE

For steam or other elevated temperature services, it is important that temperatures at the process connection do not exceed the transmitter's process temperature limits.

Figure 3-11: Installation examples

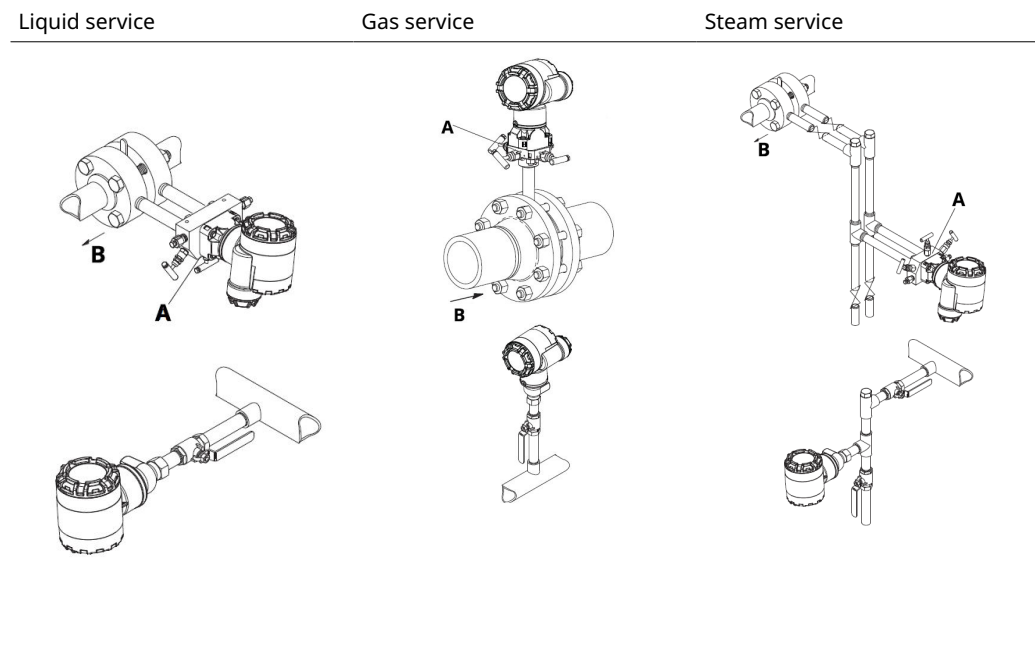

A. Drain/vent valves
B. Flow

Best practices

The piping between the process and the transmitter must accurately transfer the pressure to obtain accurate measurements.

There are six possible sources of error:

- Pressure transfer
- Leaks
- Friction loss (particularly if purging is used)
- Trapped gas in a liquid line
- Liquid in a gas line
- Density variations between the legs

The best location for the transmitter in relation to the process pipe is dependent on the process. Use the following guidelines to determine transmitter location and placement of impulse piping:

- Keep impulse piping as short as possible.
- For liquid service, slope the impulse piping at least 1 in./ft. (8 cm/m) upward from the transmitter toward the process connection.
- For gas service, slope the piping at least 1 in./ft. (8 cm/m) downward from the transmitter toward the process connection.
- Avoid high points in liquid lines and low points in gas lines.
- Ensure impulse legs are the same temperature.

- Use impulse piping large enough to avoid friction effects and blockage.
- Vent all gas from liquid piping legs.
- When using a sealing fluid, fill both piping legs to the same level.
- When purging, make the purge connection close to the process taps and purge through equal lengths of the same size pipe. Avoid purging through the transmitter.
- Keep corrosive or hot (above 250 °F [121 °C]) process material out of direct contact with the sensor modules and flanges.
- Prevent sediment deposits in the impulse piping.
- Maintain equal leg of head pressure on both legs of the impulse piping.
- Avoid conditions that might allow process fluids to freeze within the process flange.

3.3.3 Process connections

Coplanar or traditional process connection

When properly installed, the flange bolts will protrude through the top of the sensor module housing.

Flange adapters

Rosemount 3051DP and GP process connections on the transmitter flanges are 1/4–18 NPT. Flange adapters are available with standard 1/2–14 NPT Class 2 connections. The flange adapters allow users to disconnect from the process by removing the flange adapter bolts. Use plant-approved lubricant or sealant when making the process connections. This distance may be varied $\pm 1/4$ -in. (6.4 mm) by rotating one or both of the flange adapters.

To install adapters to a coplanar flange, perform the following procedure:

Procedure

1. Remove the flange bolts.
2. Leaving the flange in place, move the adapters into position with the O-ring installed.
3. Clamp the adapters and the coplanar flange to the transmitter module using the longer of the bolts supplied.
4. Tighten the bolts. Refer to [Flange bolts](#) for torque specifications.

O-rings

The two styles of Rosemount flange adapters (Rosemount 3051/2051/2024/3095) each require a unique O-ring (see [Figure 3-12](#)). Use only the O-ring designed for the corresponding flange adapter.

⚠ WARNING

Failure to install proper flange adapter O-rings may cause process leaks, which can result in death or serious injury.

The two flange adapters are distinguished by unique O-ring grooves. Only use the O-ring that is designed for its specific flange adapter, as shown in [Figure 3-12](#). When compressed, PTFE O-rings tend to cold flow, which aids in their sealing capabilities.

Figure 3-12: O-rings

ROSEMOUNT 3051S/3051/2051/3001/3095/2024

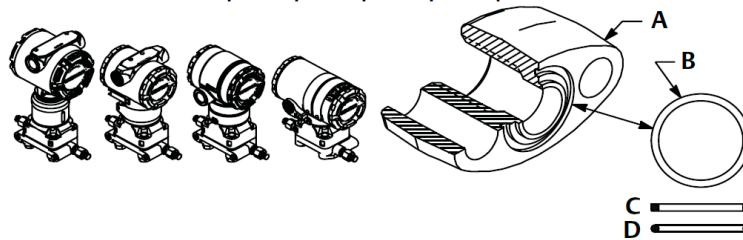

- A. Flange adapter
- B. O-ring
- C. PTFE based
- D. Elastomer

NOTICE

Replace PTFE O-rings if you remove the flange adapter.

3.3.4 Inline process connection

Inline gage transmitter orientation

NOTICE

Interfering or blocking the atmospheric reference port will cause the transmitter to output erroneous pressure values.

The low side pressure port on the inline gage transmitter is located in the neck of the transmitter, behind the housing. The vent path is 360 degrees around the transmitter between the housing and sensor (See [Figure 3-13](#)).

Keep the vent path free of any obstruction, such as paint, dust, and lubrication by mounting the transmitter so that the process can drain away.

Figure 3-13: Inline gage low side pressure port

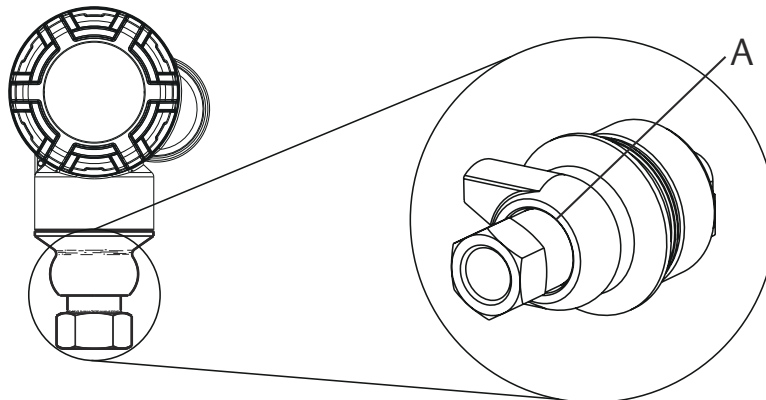

- A. Low side pressure port (atmospheric reference)

⚠ WARNING

Do not apply torque directly to the sensor module. Rotation between the sensor module and the process connection can damage the electronics. To avoid damage, apply torque only to the hex-shaped process connection.

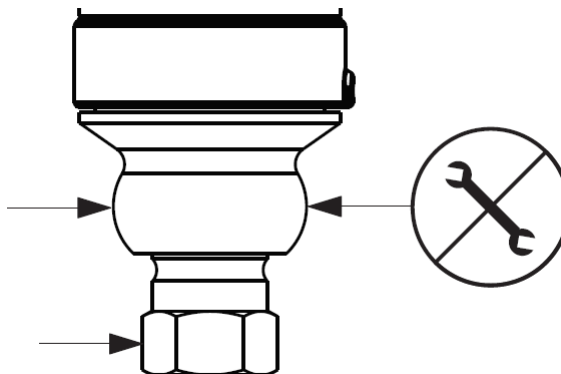

3.3.5 Power module installation

Figure 3-14: Power Module

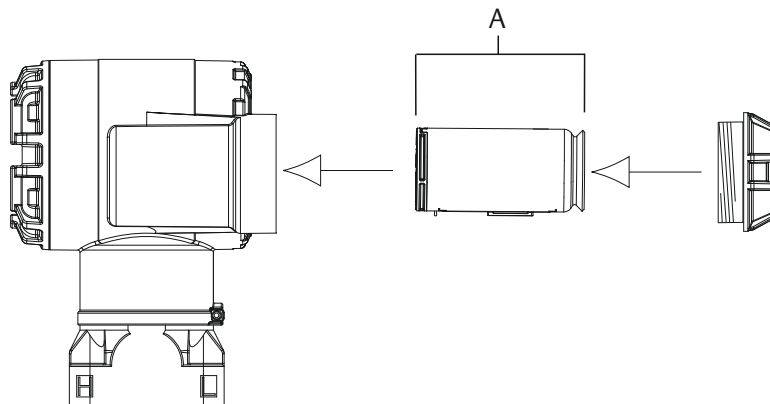

A. Power module (5/64-in. hex wrench required)

To make connections, perform the following procedure:

Procedure

1. Remove the housing cover on the power module compartment side. The power module supplies all power to the transmitter.
2. Connect Power Module 701PGNKF.
3. Replace the power module cover and tighten to safety specification (polymer to polymer).

3.3.6 Installing the LCD display

Transmitters ordered with the LCD display will be shipped with the display installed.

Note

Only use Rosemount Wireless LCD Part Number: 00753-9004-0002 An LCD display from a wired device will not function in a wireless device.

In addition to housing rotation, the optional LCD display can be rotated in 90-degree increments by squeezing the two tabs, pulling out, rotating and snapping back into place.

If LCD display pins are inadvertently removed from the interface board, carefully re-insert the pins before snapping the LCD display back into place.

Use the following procedure and [Figure 3-15](#) to install the LCD display:

Procedure

1. Remove the back cover and Power Module.
2. Remove the transmitter cover opposite the field terminal side.

⚠ WARNING

Do not remove the instrument covers in explosive environments when the circuit is live.

3. Engage the four-pin connector into the LCD display and snap into place.

Example

Note the following LCD display temperature limits:

Operating: -40 to 175 °F (-40 to 80 °C)

Storage: -40 to 185 °F (-40 to 85 °C)

Figure 3-15: Optional LCD Display

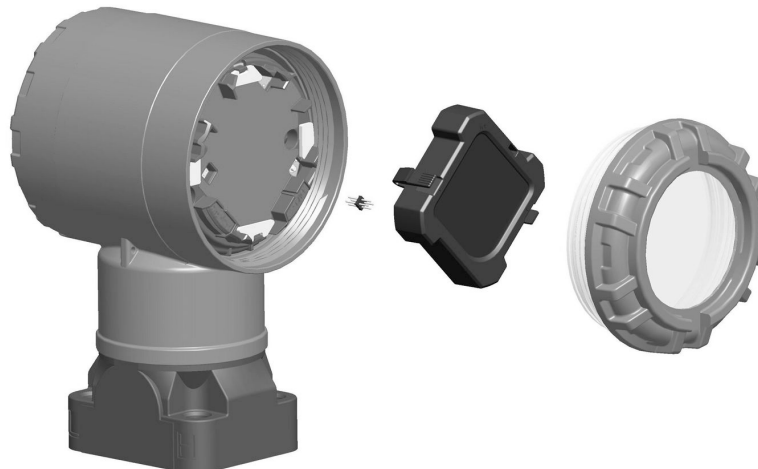

3.4 Rosemount 305, 306, and 304 manifolds

The Rosemount 305 integral manifold mounts directly to the transmitter and is available in two styles: traditional and coplanar. The traditional Rosemount 305 integral manifold can be mounted to most primary elements with mounting adapters in the market today. The Rosemount 306 integral manifold is used with the Rosemount 3051T In-Line Transmitters to provide block-and-bleed valve capabilities of up to 10000 psi (690 bar).

Figure 3-16: Manifolds

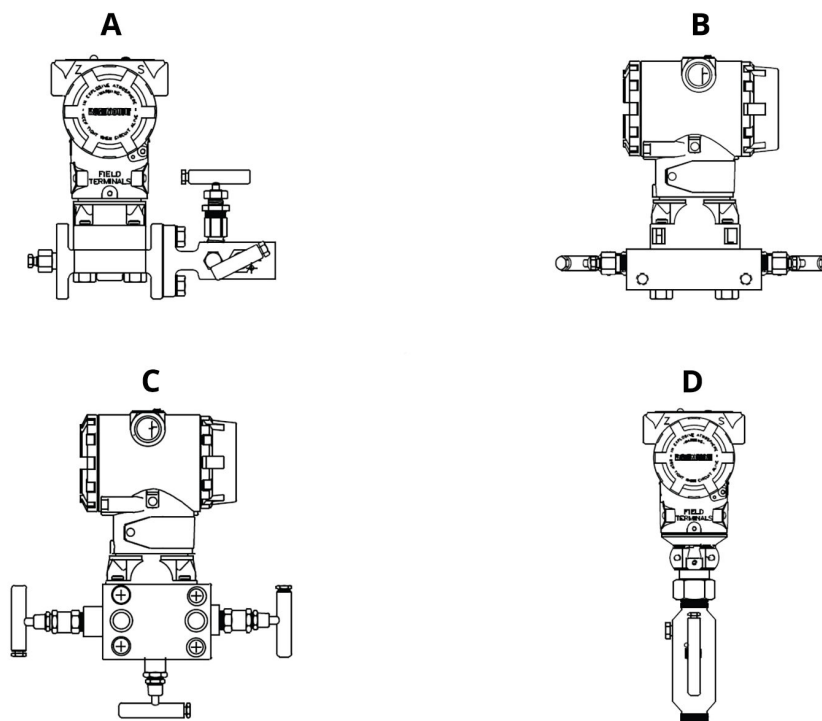

- A. Rosemount 3051C and 304 conventional
- B. Rosemount 3051C and 305 integral coplanar
- C. Rosemount 3051C and 305 integral traditional
- D. Rosemount 3051T and 306 in-line

The Rosemount 304 conventional manifold combines a traditional flange and manifold that can be mounted to most primary elements.

3.4.1 Rosemount 305 Integral Manifold installation procedure

To install a Rosemount 305 Integral Manifold to a Rosemount 3051 Wireless Transmitter:

Procedure

1. Inspect the PTFE sensor module O-rings. If the O-rings are undamaged, reusing them is recommended. If the O-rings are damaged (if they have nicks or cuts, for example), replace them with new O-rings.

Important

If replacing the O-rings, take care not to scratch or deface the O-ring grooves or the surface of the isolating diaphragm while you remove the damaged O-rings.

2. Install the integral manifold on the sensor module. Use the four 2.25-in. manifold bolts for alignment. Finger tighten the bolts, then tighten the bolts incrementally in a cross pattern as seen in [Figure 3-17](#) to final torque value. See [Flange bolts](#) for complete bolt installation information and torque values. When fully tightened, the bolts should extend through the top of the module housing.
-

Figure 3-17: Bolt Tightening Pattern

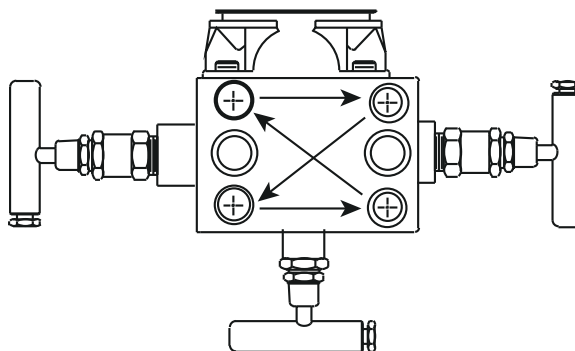

3. If the PTFE sensor module O-rings have been replaced, the flange bolts should be re-tightened after installation to compensate for cold flow of the O-rings.
 4. If applicable, install flange adapters on the process end of the manifold using the 1.75-in. flange bolts supplied with the transmitter.
-

Note

Always perform a zero trim on the transmitter/manifold assembly after installation to eliminate mounting effects. See [Sensor trim](#).

3.4.2 Rosemount 306 Integral Manifold installation procedure

The Rosemount 306 Manifold is for use only with a Rosemount 3051T Wireless In-line transmitter.

⚠ CAUTION

Assemble the Rosemount 306 Manifold to the Rosemount 3051T Wireless In-line transmitter with a thread sealant.

Procedure

1. Place transmitter into holding fixture.
 2. Apply appropriate thread paste or tape to threaded instrument end of the manifold.
 3. Count total threads on the manifold before starting assembly.
 4. Start turning the manifold by hand into the process connection on the transmitter.
-

Note

If using thread tape, be sure the thread tape does not strip when the manifold assembly is started.

5. Wrench tighten manifold into process connection.

Note

Minimum torque value is 425 in-lb.

6. Count how many threads are still showing.

Note

Minimum engagement is three revolutions.

7. Subtract the number of threads showing (after tightening) from the total threads to calculate the revolutions engaged. Further tighten until a minimum of three rotations is achieved.
8. For block and bleed manifold, verify the bleed screw is installed and tightened. For two-valve manifold, verify the vent plug is installed and tightened.
9. Leak-check assembly to maximum pressure range of transmitter.

3.4.3 Rosemount 304 Conventional Manifold installation procedure

To install a Rosemount 304 Conventional Manifold to a Rosemount 3051 Wireless Transmitter:

Procedure

1. Align the Conventional Manifold with the transmitter flange. Use the four manifold bolts for alignment.
2. Finger tighten the bolts, then tighten the bolts incrementally in a cross pattern to final torque value. See [Flange bolts](#) for complete bolt installation information and torque values. When fully tightened, the bolts should extend through the top of the sensor module housing.
3. If applicable, install flange adapters on the process end of the manifold using the 1.75-in. flange bolts supplied with the transmitter.

3.4.4 Manifold operation

⚠ WARNING

Improper installation or operation of manifolds may result in process leaks, which may cause death or serious injury.

Always perform a zero trim on the transmitter/manifold assembly after installation to eliminate any shift due to mounting effects. See [Sensor trim](#).

Coplanar transmitters Perform a zero trim on 3 and 5-valve manifolds

Perform zero trim at static line pressure.

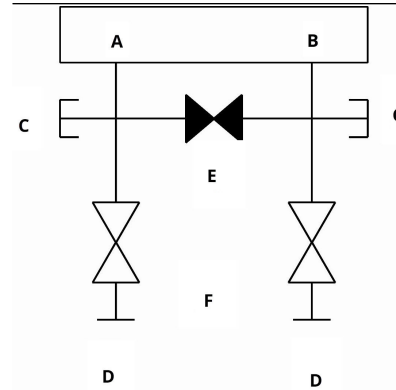

- A. High
- B. Low
- C. Drain/vent valve
- D. Isolate (open)
- E. Equalize (closed)
- F. Process

Procedure

1. To zero the Rosemount 3051, close the block valve to the low pressure (downstream) side first.

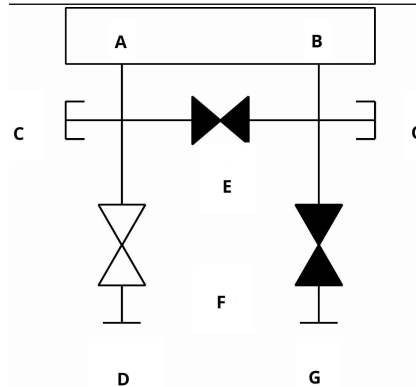

- A. High
- B. Low
- C. Drain/vent valve
- D. Isolate (open)
- E. Equalize (closed)
- F. Process
- G. Isolate (closed)

2. Open the equalize valve to equalize the pressure on both sides of the transmitter.
Open the center (equalize) valve to equalize the pressure on both sides of the transmitter.

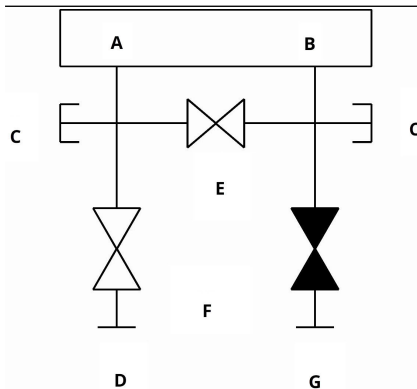

- A. High
- B. Low
- C. Drain/vent valve
- D. Isolate (open)
- E. Equalize (open)
- F. Process
- G. Isolate (closed)

3. After zeroing the transmitter, close the equalize valve.

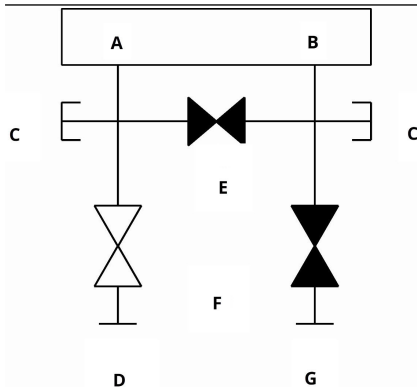

- A. High
- B. Low
- C. Drain/vent valve
- D. Isolate (open)
- E. Equalize (closed)
- F. Process
- G. Isolate (closed)

4. Finally, to return the transmitter to service, open the low side isolate valve.

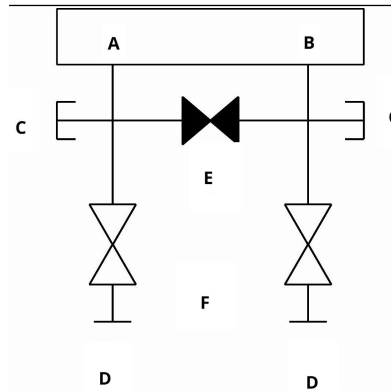

- A. High
- B. Low
- C. Drain/vent valve
- D. Isolate (open)
- E. Equalize (closed)
- F. Process

Zero a five-valve natural gas manifold

Perform zero trim at static line pressure.

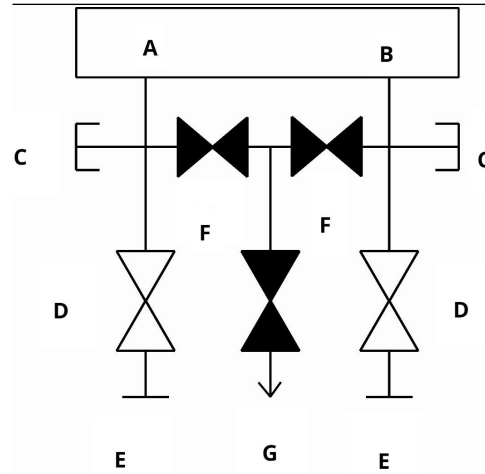

- A. High
- B. Low
- C. Isolate (open)
- D. Process
- E. Equalize (closed)
- F. Drain vent (closed)

Procedure

1. To zero trim the transmitter, first close the isolate valve on the low pressure (downstream) side of the transmitter and the vent valve.

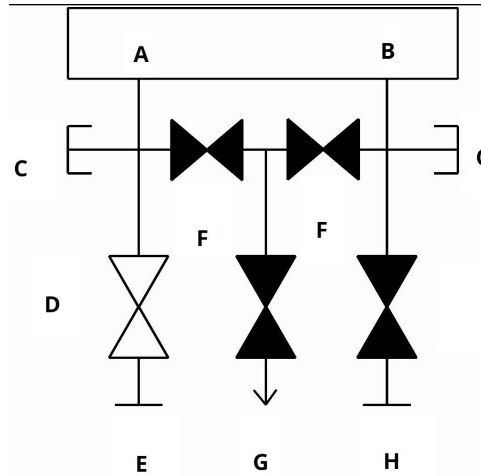

- A. High
- B. Low
- C. Isolate (open)
- D. Process
- E. Equalize (closed)
- F. Drain vent (closed)
- G. Isolate (closed)

2. Open the equalize valve on the high pressure (upstream) side of the transmitter.

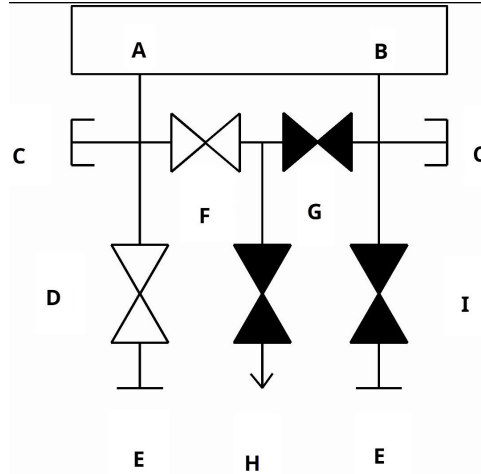

- A. High
- B. Low
- C. Isolate (open)
- D. Process
- E. Equalize (open)
- F. Equalize (closed)
- G. Drain vent (closed)
- H. Isolate (closed)

3. Open the equalize valve on the low pressure (downstream) side of the transmitter. The manifold is now in the proper configuration for zeroing the transmitter.

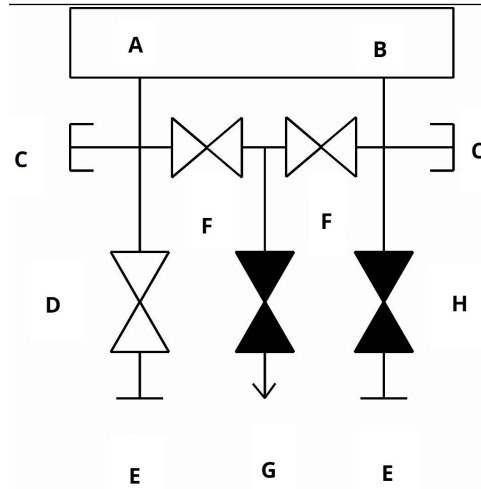

- A. High
- B. Low
- C. Isolate (open)
- D. Process
- E. Equalize (open)
- F. Drain vent (closed)
- G. Isolate (closed)

4. After zeroing the transmitter, close the equalize valve on the low pressure (downstream) side of the transmitter.

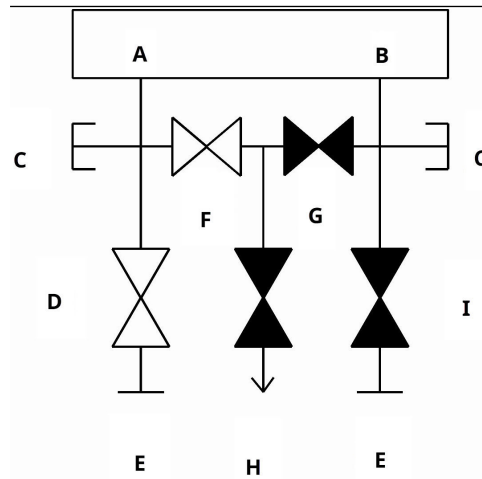

- A. High
- B. Low
- C. Isolate (open)
- D. Process
- E. Equalize (open)
- F. Equalize (closed)
- G. Drain vent (closed)
- H. Isolate (closed)

5. Close the equalize valve on the high pressure (upstream) side.

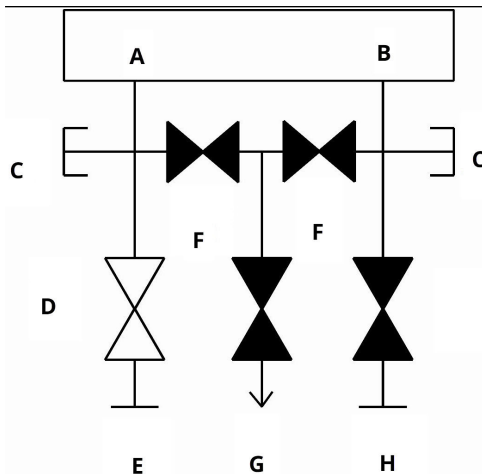

- A. High
- B. Low
- C. Isolate (open)
- D. Process
- E. Equalize (closed)
- F. Drain vent (closed)
- G. Isolate (closed)

6. Finally, to return the transmitter to service, open the low side isolate valve and vent valve.

The vent valve can remain open or closed during operation.

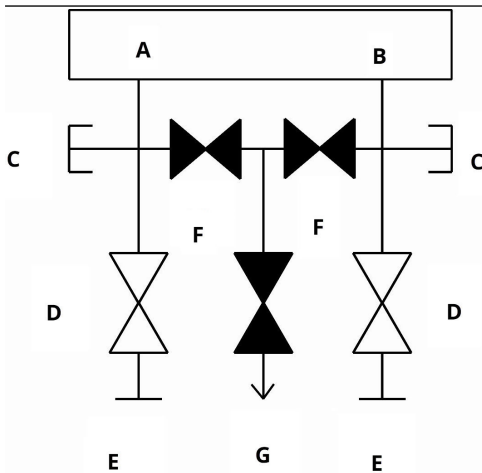

- A. High
- B. Low
- C. Isolate (open)
- D. Process
- E. Equalize (closed)
- F. Drain vent (closed)

In-line transmitters

Isolating the transmitter 2-valve and block and bleed style manifolds

In normal operation the isolate (block) valve between the process port and transmitter will be open and the test/vent valve will be closed. On a block and bleed style manifold, a single block valve provides transmitter isolation and a bleed screw provides drain/vent capabilities.

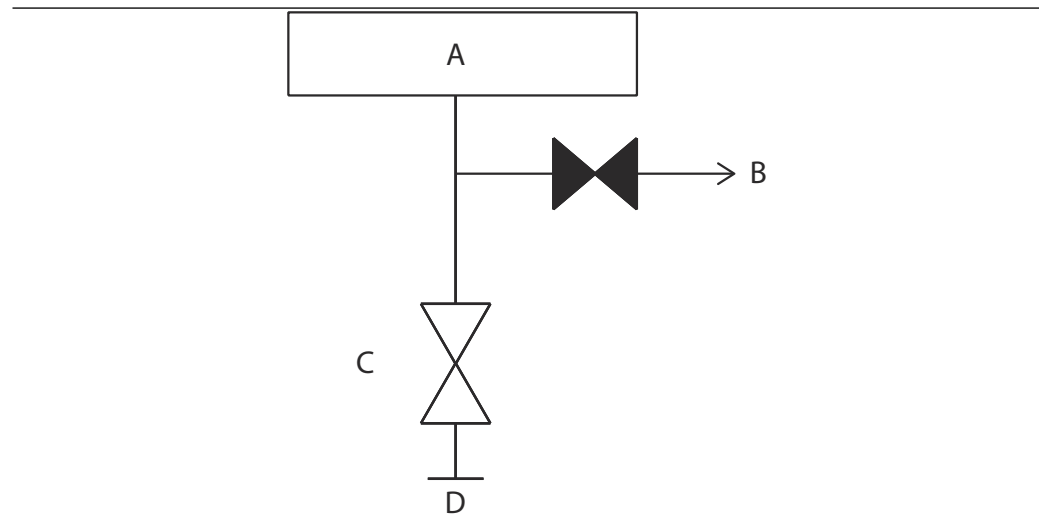

- A. Transmitter
- B. Vent (closed)
- C. Isolate
- D. Process (open)

Procedure

1. To isolate the transmitter, close the isolate valve.

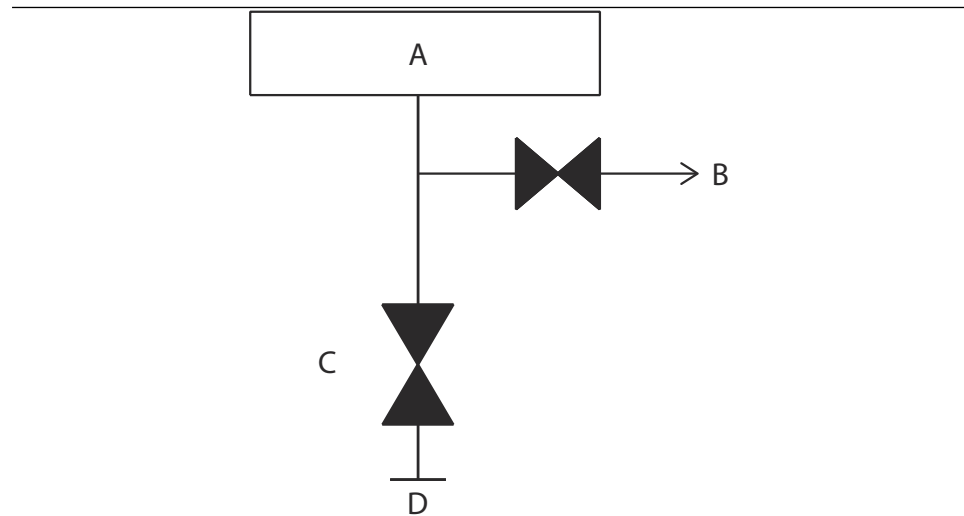

- A. Transmitter
- B. Vent (closed)
- C. Isolate
- D. Process (closed)

2. To bring the transmitter to atmospheric pressure, open the vent valve or bleed screw.

Note

A 1/4-in. male NPT pipe plug may be installed in the test/vent port and will need to be removed with a wrench in order to vent the manifold properly.

⚠ CAUTION

Always use caution when venting directly to atmosphere.

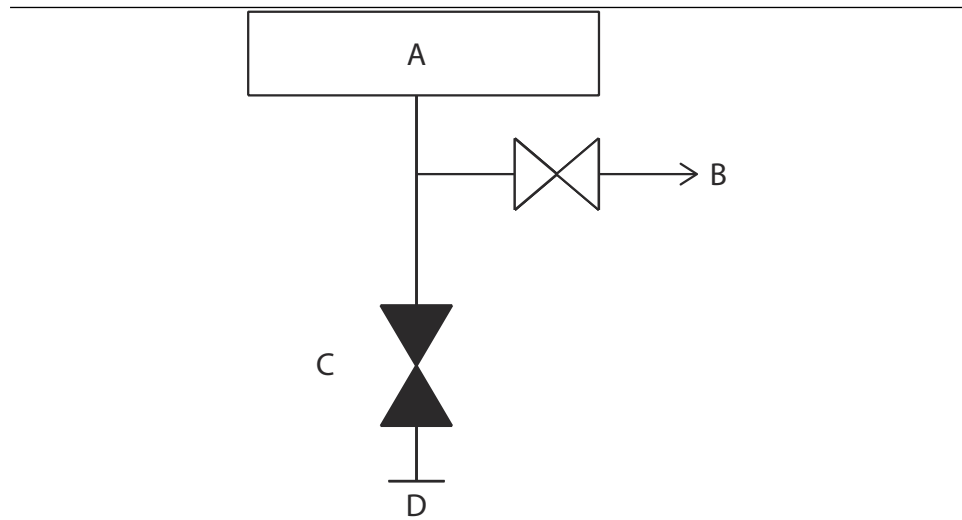

- A. Transmitter
- B. Vent (open)
- C. Isolate
- D. Process (closed)

3. After venting to atmosphere, perform any required calibration and then close the test/vent valve or replace the bleed screw.

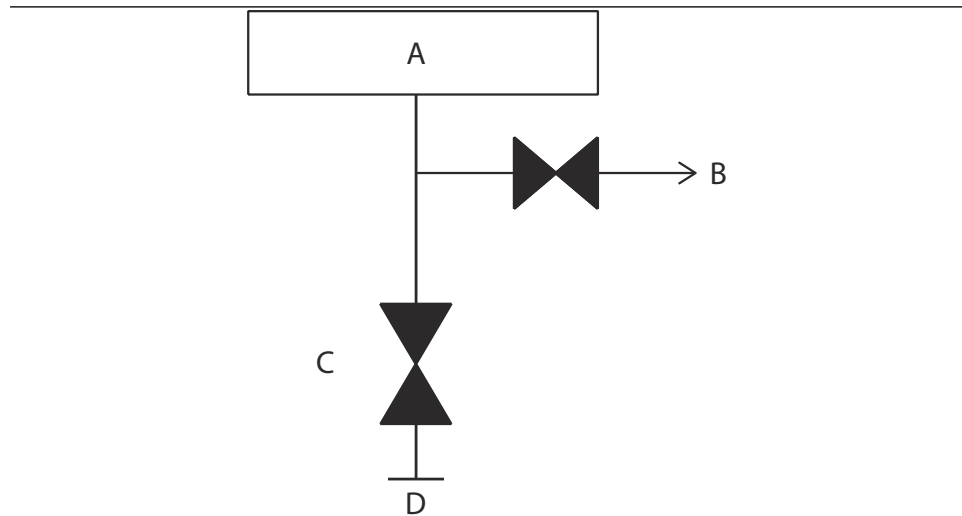

- A. Transmitter
- B. Vent (closed)
- C. Isolate
- D. Process (closed)

4. Open the Isolate (block) valve to return the transmitter to service.

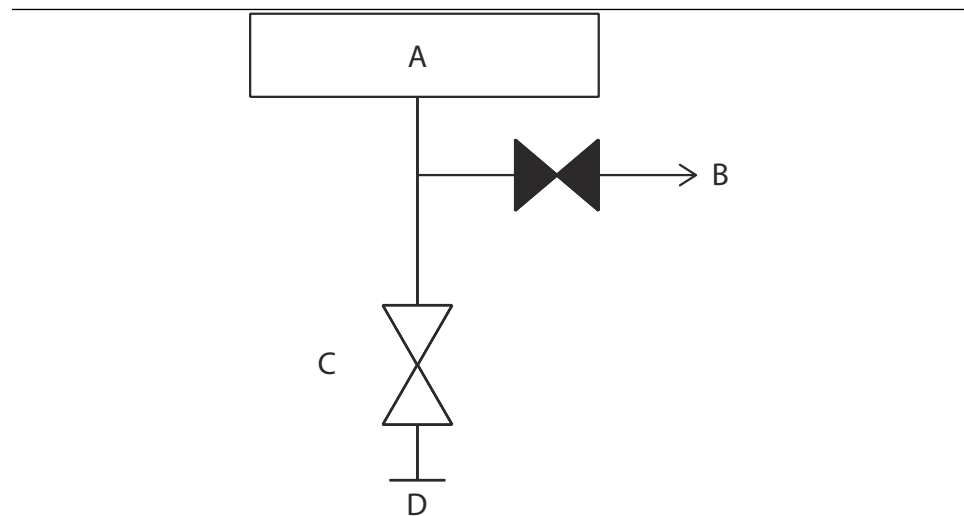

- A. Transmitter
- B. Vent (closed)
- C. Isolate
- D. Process (closed)

Adjusting valve packing

Over time, the packing material inside a Rosemount manifold may require adjustment in order to continue to provide proper pressure retention. Not all manifolds have this adjustment capability. The manifold model number will indicate what type of stem seal or packing material has been used.

The following steps are provided as a procedure to adjust valve packing:

Procedure

1. Remove all pressure from device.
2. Loosen manifold valve jam nut.
3. Tighten manifold valve packing adjuster nut 1/4 turn.
4. Tighten manifold valve jam nut.
5. Re-apply pressure and check for leaks.
6. Above steps can be repeated, if necessary.

If the above procedure does not result in proper pressure retention, the complete manifold should be replaced.

Figure 3-18: Adjusting Valve Packing

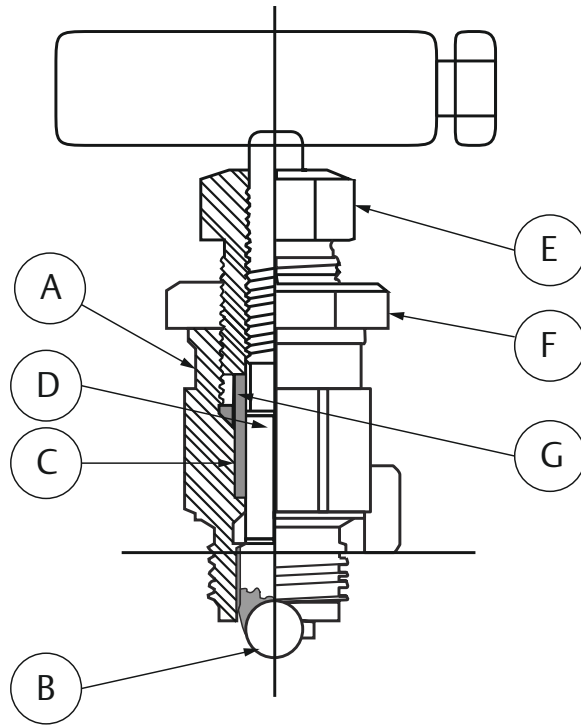

- A. Bonnet
- B. Ball seat
- C. Packing
- D. Stem
- E. Packing adjuster
- F. Jam nut
- G. Packing follower

WirelessHART® Installation Flowchart

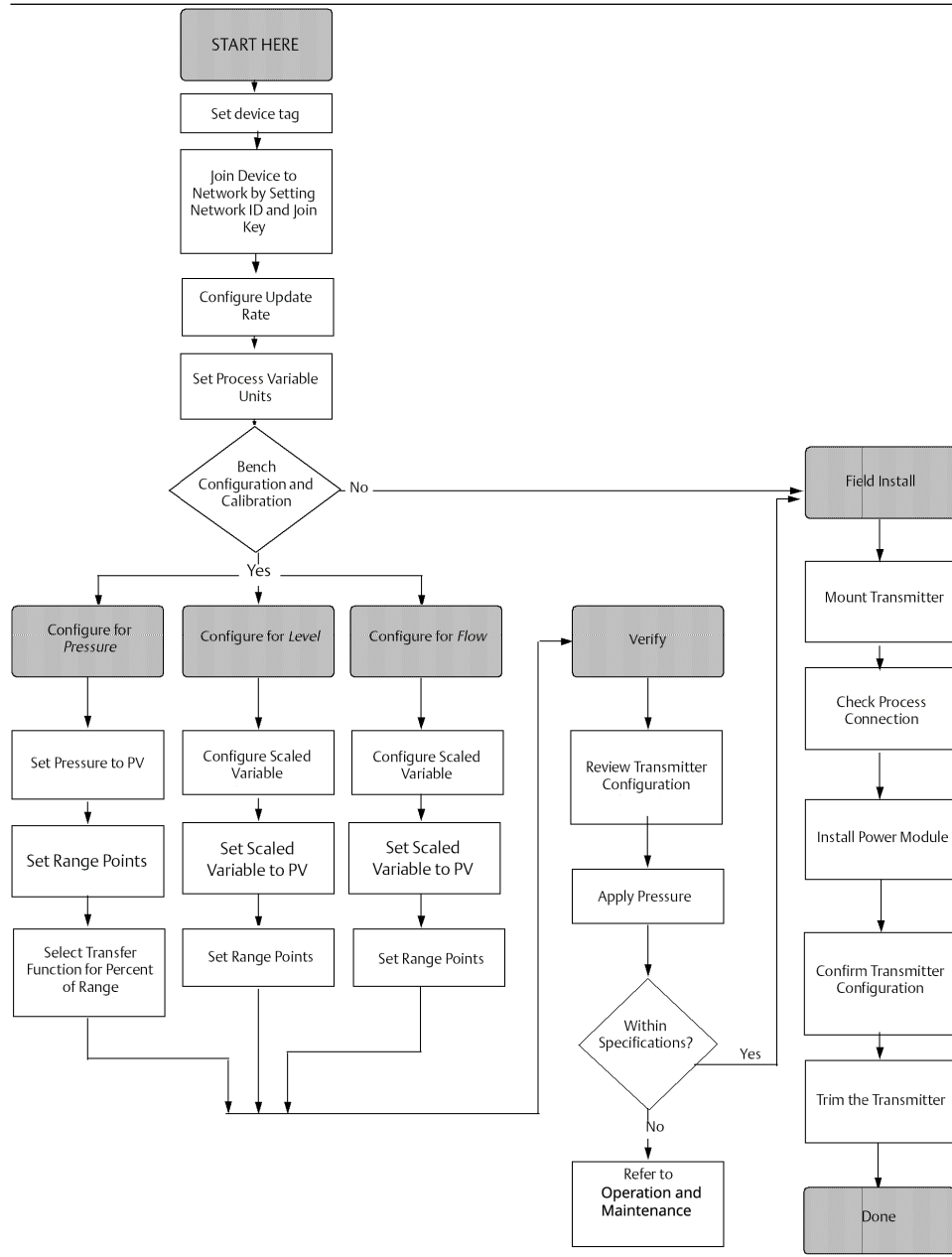

4 Commissioning

4.1 Overview

The information in this section covers installation considerations for the Rosemount™ 3051 Wireless Pressure Transmitter. A Quick Start Guide is shipped with every transmitter to describe pipe-fitting, wiring procedures and basic configuration for initial installation.

Note

For transmitter disassembly refer to sections [Removing from service](#).

4.2 Viewing network status

If the Rosemount 3051 Wireless was configured with the Network ID and Join Key and sufficient time for network polling has passed, the transmitter should be connected to the network. To verify connectivity, open the Smart Wireless Gateway's integral web interface and navigate to the **Explorer** page.

The screenshot shows the 'Explorer' page of the Smart Wireless Gateway. It features a table with columns for HART Tag, HART status, Last update, PV, SV, TV, QV, and Burst rate. The table lists various tags such as '248 Temperature', '3051 screen battery', '3051SHV-INST', '3051SHV-THUM', '5600-THUM', '8732-INST', '8732-THUM', 'ACOUSTIC-TO8', 'Demount', 'PT-AR1', 'STEM708YDF', and 'DCC-REV4'. Each tag has a green status indicator, except for 'ACOUSTIC-TO8' which has a yellow warning icon. The interface includes a navigation menu on the left and a footer with copyright information.

HART Tag	HART status	Last update	PV	SV	TV	QV	Burst rate
248 Temperature	●	11/28/12 08:56:44	NaN DegC	NaN DegF	75.200 DegF	6.022 V	00:01:00
3051 screen battery - Item 2	●	11/28/12 08:57:13	0.030 PSI	24.230 DegC	23.750 DegC	3.684 V	8
3051SHV-INST	●						
3051SHV-THUM	●						
5600	●	11/28/12 08:56:35	28.215 m	1.785 m	2045.642 mV	-0.011 m/hr	00:01:00
5600-THUM	●	11/28/12 08:56:35	24.438 DegC				00:01:00
8732-INST	●						
8732-THUM	●	11/28/12 08:56:27	28.063 DegC				00:01:00
ACOUSTIC-TO8	●	11/28/12 08:56:59	0.000 counts	24.745 DegC	25.250 DegC	3.595 V	00:01:00
Demount	●	11/28/12 08:57:06	NaN ft	NaN ft	23.250 DegC 11/28/12 08:54:05	8.301 V 11/28/12 08:54:05	00:01:00
PT-AR1	●	11/28/12 08:57:05	0.013 InH2O 68F	23.635 DegC	23.750 DegC	8.324 V	00:01:00
STEM708YDF	●	11/28/12 08:53:55	NaN counts	NaN DegC	23.750 DegC	2.641 V	00:05:00
DCC-REV4	●	11/28/12 08:56:51	12.000	0.000	34.750 DegC	35.250 DegC	

This page will display the transmitter's HART® tag, PV, SV, TV, QV, and Update Rate. A green status indicator means that the device is working properly. A red indicator means that there is a problem with either the device or its communication path. For more detail on a specific device, click on the tag name.

4.3 Verifying operation

Operation can be verified in four locations, at the device via the Local Display, using the Communication Device, at the Smart Wireless Gateway's integrated web interface, or by using AMS Suite Wireless Configurator or AMS Device Manager.

4.3.1 LCD display

The LCD display will display the PV value at the same rate as the configured update rate. Press the Diagnostic button to display the **TAG**, **Device ID**, **Network ID**, **Network Join Status** and **Device Status** screens.

For **Device Status** screens, see [LCD display screen messages](#).

Table 4-1: Diagnostic Screen Sequence

Tag	Device ID	Network ID	Network join status	Device status

Table 4-2: Network Join Status Screens

Searching for network	Joining network	Connected with limited bandwidth	Connected

4.3.2 Communication Device

For HART Wireless transmitter communication, a Rosemount 3051 Wireless DD is required. To obtain the latest DD, visit the Emerson Easy Upgrade site at: [Emerson.com/Rosemount/Device-Install-Kits](https://www.emerson.com/rosemount-device-install-kits). The communication status may be verified in the wireless device using the following Fast Key sequence.

Function	Fast Key sequence	Menu items
Communications	3, 4	Join Status, Join Mode, Number of Available Neighbors, Number of Advertisements Heard, Number of Join Attempts

4.3.3 Smart Wireless Gateway

Using the Gateway's web interface, navigate to the **Explorer** page as shown in Figure 4-1. Locate the device in question and verify all status indicators are good (green).

Figure 4-1: Smart Wireless Gateway Explorer page

HART Tag	HART status	Last update	PV	SV	TV	QV	Burst rate
248 Temperature	●	11/28/12 08:56:44	NaN DegC	NaN DegF	75.200 DegF	6.022 V	00:01:00
3051 screen battery	●	11/28/12 08:57:13	0.030 PSI	24.230 DegC	23.750 DegC	3.684 V	8
3051SHV-INST	●						
3051SHV-THUM	●						
5600	●	11/28/12 08:56:35	28.215 m	1.785 m	2045.642 mV	-0.011 mV/h	00:01:00
5600-THUM	●	11/28/12 08:56:35	24.438 DegC				00:01:00
8732-INST	●						
8732-THUM	●	11/28/12 08:56:27	28.063 DegC				00:01:00
ACOUSTIC-T08	●	11/28/12 08:56:59	0.000 counts	24.745 DegC	25.250 DegC	3.995 V	00:01:00
DEMO-UMS	●	11/28/12 08:57:06	NaN ft	NaN ft	23.250 DegC 11/28/12 08:54:05	8.301 V 11/28/12 08:54:05	00:01:00
PT-AB1	●	11/28/12 08:57:08	0.013 InH2O 68F	23.635 DegC	23.750 DegC	8.324 V	00:01:00
STEAM708Y2F	●	11/28/12 08:53:55	NaN counts	NaN DegC	23.750 DegC	2.641 V	00:05:00
psc-rev4	●	11/28/12 08:56:51	12.000	0.000	34.750 DegC	35.250 DegC	

4.3.4 AMS Device Manager

When the device has joined the network, it will appear in the **Device Manager** as illustrated in Figure 4-2. For HART Wireless Transmitter Communication, a Rosemount 3051 Wireless DD is required. To obtain the latest DD, visit the Emerson Easy Upgrade site at: Emerson.com/Rosemount/Device-Install-Kits.

Figure 4-2: Device Manager

Tag	Manufacturer	Device Ty...	Device Rev	Protocol	Protocol ...
160119/2011 10:49:36.530	Rosemount	708	1	HART	7

4.3.5 Using the Communication Device

Note

In order to communicate with a Communication Device, power the Rosemount 3051 Wireless by connecting the power module. For more information on the Power Module, refer to the Emerson SmartPower Module [Product Data Sheet](#).

Table 4-3 includes Fast Key sequences frequently used to interrogate and configure the device.

Table 4-3: Rosemount 3051 Wireless Fast Key Sequence

Function	Fast Key sequence	Menu Items
Device Information	2, 2, 8	Identification, Model Numbers, Flange Information, Remote Seal Information, Serial Number
Guided Setup	2, 1	Basic Setup, Join Device to Network, Configure Update Rates, Alert Setup
Manual Setup	2, 2	Wireless, Sensor, HART, Security, Device Information, Power
Wireless	2, 2, 1	Network ID, Join Device to Network, Broadcast Information

Figure 4-3: Communication Device Connections

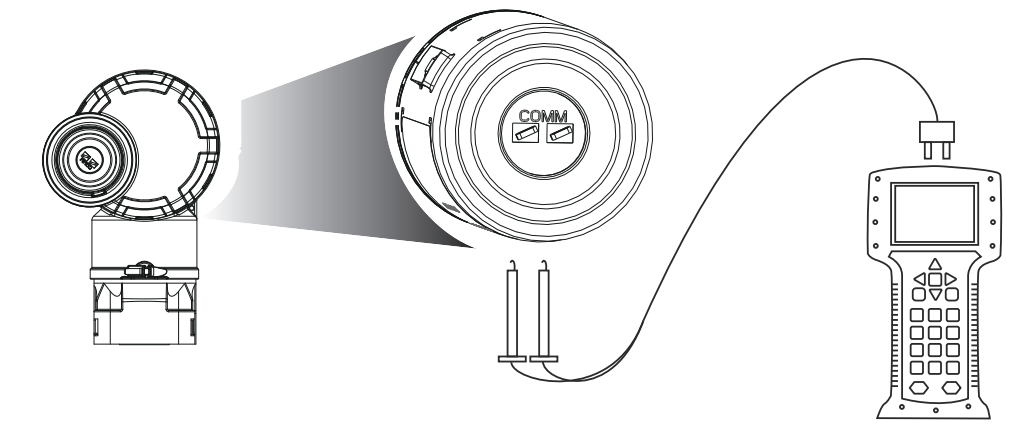

4.4 Configuring transmitter security

There are two security methods with the Rosemount 3051 Wireless Transmitter.

- HART Lock
- Configuration Buttons Lock

4.4.1 HART® Lock

The HART Lock prevents changes to the transmitter configuration from all sources; all changes requested via HART and local configuration buttons will be rejected. The HART

Lock can only be set via HART Communication. The HART Lock can be enabled or disabled with a Communication Device or AMS Device Manager.

4.4.2 Configuring HART® Lock using Communication Device

Procedure

- From the **HOME** screen, enter the Fast Key sequence.

Device Dashboard Fast Keys	2, 2, 6, 2
----------------------------	------------

4.4.3 Configuring HART® Lock using AMS Device Manager

Procedure

- Right click on the device and select **Configure**.
- Under **Manual Setup** select the **Security** tab.
- Select **Lock/Unlock** button under **HART Lock (Software)** and follow the screen prompts.

4.4.4 Configuration button lock

The configuration button lock disables all local button functionality. Changes to the transmitter configuration from the local buttons will be rejected. Local external keys can be locked via HART Communication only.

4.4.5 Configuring configuration button lock using a Communication Device

Procedure

- From the **HOME** screen, enter the Fast Key sequence.

Device Dashboard Fast Keys	2, 2, 6, 1
----------------------------	------------

4.4.6 Configuring configuration button lock using AMS device Manager

Procedure

- Right click on the device and select **Configure**.
- Under **Manual Setup** select the **Security** tab.
- Within the Configuration Buttons dropdown menu select **Disabled** to lock external local keys.
- Select **Send**.
- Confirm service reason and select **Yes**.

5 Operation and Maintenance

5.1 Overview

This section contains information on commissioning and operating Rosemount™ 3051 Wireless Pressure Transmitters.

Communication Device and AMS Device Manager instructions are given to perform configuration functions. For convenience, Communication Device Fast Key sequences are labeled “Fast Keys” for each software function below the appropriate headings.

5.2 Calibration overview

Calibrating a Rosemount 3051 Wireless may include the following procedures:

- **Sensor trim:** Adjusts the position of the factory sensor characterization curve to optimize performance over a specified pressure range, or to adjust for mounting effects.

The Rosemount 3051 Sensor Module contains information about the sensor’s specific characteristics in response to pressure and temperature inputs. A smart transmitter compensates for these sensor variations. The process of generating the sensor performance profile is called factory sensor characterization.

Sensor trimming requires an accurate pressure input and adds additional compensation that adjusts the position of the factory sensor characterization curve to optimize performance over a specific pressure range.

Note

Sensor trimming adjusts the position of the factory sensor characterization curve. It is possible to degrade performance of the transmitter if the trim is done improperly or with inaccurate equipment.

NOTICE

Absolute pressure transmitters (Rosemount 3051CA and 3051TA) are calibrated at the factory. Trimming adjusts the position of the factory characterization curve. It is possible to degrade performance of the transmitter if any trim is done improperly or with inaccurate equipment.

Table 5-1: Recommended Calibration Tasks

Transmitter	Bench calibration tasks	Field calibration tasks
Rosemount 3051CD 3051CG 3051L 3051TG, Range 1-4	<ol style="list-style-type: none"> 1. Set output configuration parameters: <ol style="list-style-type: none"> a. Set the range points. b. Set the output units. c. Set the output type. 2. Optional: Perform a sensor trim. (Accurate pressure source required.) 	<ul style="list-style-type: none"> • Reconfigure parameters if necessary. • Zero trim the transmitter to compensate for mounting effects or static pressure effects.

Table 5-1: Recommended Calibration Tasks (continued)

Transmitter	Bench calibration tasks	Field calibration tasks
Rosemount 3051CA 3051TA 3051TG, Range 5	<ol style="list-style-type: none"> 1. Set output configuration parameters: <ol style="list-style-type: none"> a. Set the range points. b. Set the output units. c. Set the output type. 2. Optional: Perform a sensor trim if equipment available (accurate absolute pressure source required), otherwise perform the low trim value section of the sensor trim procedure. 	<ol style="list-style-type: none"> 1. Reconfigure parameters if necessary. 2. Perform low trim value section of the sensor trim procedure to correct for mounting position effects.

Note

For Rosemount 3051CA, 3051TA Range 0 and 5 devices, an accurate absolute pressure source is required.

5.2.1 Determining necessary sensor trims

Bench calibrations allow for calibrating the instrument for its desired range of operation. Straight forward connections to pressure source allow for a full calibration at the planned operating points. Exercising the transmitter over the desired pressure range allows for verification of the output value. [Sensor trim](#) discusses how the trim operations change the calibration. It is possible to degrade the performance of the transmitter if a trim is done improperly or with inaccurate equipment. The transmitter can be set back to factory settings using the recall factory trim command in [Recall factory trim—sensor trim](#).

For transmitters that are field installed, the manifolds discussed in [Rosemount 305, 306, and 304 manifolds](#) allow the differential transmitter to be zeroed using the zero trim function. Both 3- and 5-valve manifolds are discussed. This field calibration will eliminate any pressure offsets caused by mounting effects (head effect of the oil fill) and static pressure effects of the process.

Determine the necessary trims with the following steps.

Procedure

1. Apply pressure.
2. Check digital pressure, if the digital pressure does not match the applied pressure, perform a digital zero trim. See [Sensor trim](#).

Trimming with configuration buttons

Local configuration buttons are buttons located inside the housing of the transmitter. To access the buttons, remove the housing cover.

- **Digital Zero Trim (DZ):** Used for performing a sensor zero trim. See [Sensor trim overview](#) for trim instructions.

[Figure 5-1](#) shows the location of the **Digital Zero** button.

Figure 5-1: Digital Zero button location

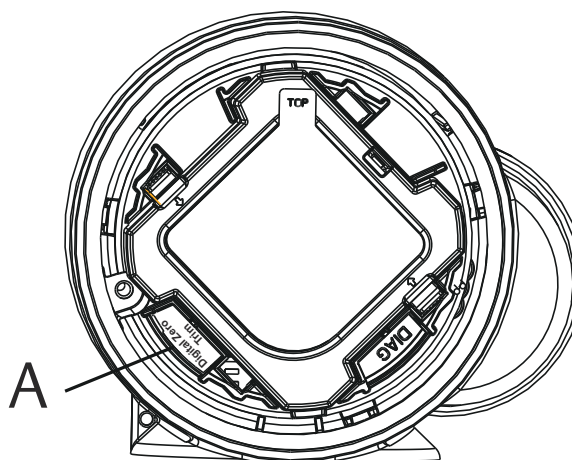

A. **Digital Zero** button

5.2.2 Determine calibration frequency

Calibration frequency can vary greatly depending on the application, performance requirements, and process conditions. See [How to Calculate Pressure Transmitter Calibration Intervals Technical Note](#).

To determine the calibration frequency that meets the needs of your application:

Procedure

1. Determine the performance required for your application.
2. Determine the operating conditions.
3. Calculate the Total Probable Error (TPE).
4. Calculate the stability per month.
5. Calculate the calibration frequency.

Sample calculation for Rosemount 3051 (0.04 percent accuracy and 10-year stability)

The following is an example of how to calculate calibration frequency:

Procedure

1. Determine the performance required for your application.

Required performance	0.20% of span
-----------------------------	---------------

2. Determine the operating conditions.

Transmitter	Rosemount 3051CD, Range 2 (upper range value URL = 250 inH ₂ O [6.2 bar])
--------------------	--

Calibrated span	150 inH ₂ O (3.7 bar)
------------------------	----------------------------------

Line pressure	500 psig (34.5 barg)
----------------------	----------------------

3. Calculate Total Probable Error (TPE).

$$\text{TPE} = \sqrt{(\text{ReferenceAccuracy})^2 + (\text{TemperatureEffect})^2 + (\text{StaticPressureEffect})^2} = 0.105\%$$

of span

Where:

Reference Accuracy	$\pm 0.04\%$ of span
Ambient Temperature Effect	$\left(\frac{(0,0125 \times \text{URL})}{\text{Span}} + 0,0625\right)\%$ per 50 °F = $\pm 0,0833\%$ of span
Span Static Pressure Effect	(1) 0,1% reading per 1000 psi (69 bar) = $\pm 0,05\%$ of span

4. Calculate the stability per month.

$$\text{Stability} = \pm \left[\frac{0,2 \times \text{URL}}{\text{Span}} \right] \% \text{ of span for 10 years} = \pm 0,00278\% \text{ of span for 1 month}$$

5. Calculate calibration frequency.

$$\text{Calibration frequency} = \frac{\text{Req. Performance} - \text{TPE}}{\text{Stability per month}} = \frac{0,2\% - 0,105\%}{0,00278\%} = 34 \text{ months}$$

5.2.3 Compensating for span line pressure effects (Range 4 and 5)

Rosemount 3051 Range 4 and 5 Pressure Transmitters require a special calibration procedure when used in differential pressure applications. The purpose of this procedure is to optimize transmitter performance by reducing the effect of static line pressure in these applications.

The Rosemount Differential Pressure Transmitters (Ranges 1 through 3) do not require this procedure because optimization occurs at the sensor.

The systematic span shift caused by the application of static line pressure is -0.95 percent of reading per 1000 psi (69 bar) for Range 4 transmitters and -1 percent of reading per 1000 psi (69 bar) for Range 5 transmitters.

5.3 Trim the pressure signal

5.3.1 Sensor trim overview

A sensor trim corrects the pressure offset and pressure range to match a pressure standard. The upper sensor trim corrects the pressure range and the lower sensor trim (zero trim) corrects the pressure offset. An accurate pressure standard is required for full calibration. A zero trim can be performed if the process is vented, or the high and low side pressure are equal (for differential pressure transmitters).

Zero trim is a single-point offset adjustment. It is useful for compensating for mounting position effects and is most effective when performed with the transmitter installed in its final mounting position. Since this correction maintains the slope of the characterization curve, it should not be used in place of a sensor trim over the full sensor range.

(1) Zero static pressure effect removed by zero trimming at line pressure.

When performing a zero trim, ensure the equalizing valve is open and all wet legs are filled to the correct levels. Line pressure should be applied to the transmitter during a zero trim to eliminate line pressure errors. Refer to [Manifold operation](#).

Note

Do not perform a zero trim on Rosemount 3051 Wireless Absolute Pressure Transmitters. Zero trim is zero based, and absolute pressure transmitters reference absolute zero. To correct mounting position effects on a Rosemount 3051 Wireless, perform a low trim within the sensor trim function. The low trim function provides an offset correction similar to the zero trim function, but it does not require zero-based input.

Sensor trim is a 2-point sensor calibration where two end-point pressures are applied, and all output is linearized between them. Always adjust the low trim value first to establish the correct offset. Adjustment of the high trim value provides a slope correction to the characterization curve based on the low trim value. The trim values allow you to optimize performance over your specified measuring range at the calibration temperature.

During a trim operation, the Rosemount 3051 Wireless is placed in high power refresh mode, which provides frequent pressure measurement updates and allows the configured damping to take effect. This behavior allows for more accurate calibration of the device. When the device is in high power refresh mode, the battery power supply will be depleted more rapidly.

Figure 5-2: Sensor Trim Example

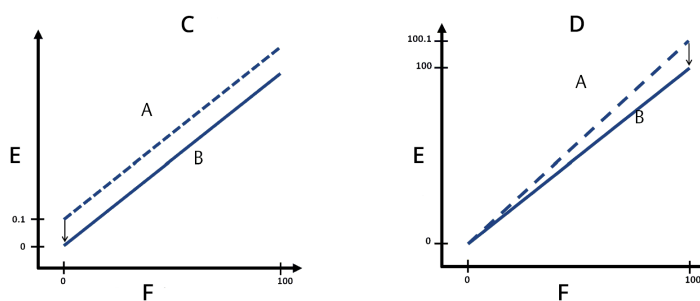

- A. Before trim
- B. After trim
- C. Zero/Lower Sensor Trim
- D. Upper Sensor Trim
- E. Pressure Reading
- F. Pressure Input

5.3.2

Sensor trim

When performing a sensor trim, both the upper and lower limits can be trimmed. If both upper and lower trims are to be performed, the lower trim must be done prior to the upper trim.

Note

Use a pressure input source that is at least four times more accurate than the transmitter, and allow the input pressure to stabilize for ten seconds before entering any values.

Performing a sensor trim with a Communication Device

From the **Home** screen, enter the Fast Key sequence and follow the steps within the Communication Device to complete the sensor trim.

Device Dashboard Fast Keys	3, 5, 1, 1
----------------------------	------------

To calibrate the transmitter using the sensor trim function:

Procedure

1. Assemble and power the entire calibration system including the Rosemount 3051, Communication Device/AMS Device Manager, power supply, pressure input source, and readout device.
2. From the **Home** screen, select **3: Service Tools**.
3. Select **5: Maintenance**.
4. Select **1: Calibration**.
5. Select **1: Sensor Trim**.
6. Select **2: Lower Sensor Trim**. The lower sensor trim value should be the sensor trim point that is closest to zero.

Note

Select pressure points so that lower and upper values are equal to or outside the expected process operation range.

7. Follow the on-screen instructions to complete the adjustment of the lower value.
8. Repeat the procedure for the upper value. Select **1: Upper Sensor Trim** and follow the on-screen instructions to complete the adjustment of the upper value.

Perform a sensor trim using AMS Device Manager

Procedure

1. Right-click the device and go to **Method** → **Calibrate** → **Sensor Trim** → **Lower Sensor Trim**.
2. Follow the screen prompts to perform a sensor trim using AMS Device Manager.
3. If desired, right-click the device again and go to **Method** → **Calibrate** → **Sensor Trim** → **Upper Sensor Trim**

Performing a Digital Zero Trim (option DZ)

A Digital Zero Trim (option DZ) provides the same function as a zero/lower sensor trim, but can be completed in hazardous areas at any given time by simply pushing the zero trim button when the transmitter is at zero pressure. If the transmitter is not close enough to zero when the button is pushed, the command may fail due to excess correction. If ordered, a Digital Zero Trim can be performed by utilizing configuration buttons located inside the housing of the transmitter, see [Figure 5-1](#) for DZ button location.

Procedure

1. Remove the electronics housing cover.
2. Press and hold the **Digital Zero** button for at least two seconds then release to perform a Digital Zero Trim

5.3.3 Recall factory trim—sensor trim

The Recall Factory Trim—Sensor Trim command allows the restoration of the as-shipped factory settings of the Sensor Trim. This command can be useful for recovering from an inadvertent zero trim of an absolute pressure unit or inaccurate pressure source.

Recalling factory trim with Communication Device

Procedure

- From the **HOME** screen, enter the Fast Key sequence and follow the steps within the Communication Device to complete the Sensor Trim.

Device Dashboard Fast Keys	3, 5, 1, 2
----------------------------	------------

Recalling factory trim with AMS Device Manager

Right click on the device and, under the **Method drop down menu** → **Calibrate** → **Restore Factory Calibration**.

Procedure

- Click **Next** after setting the control loop to manual.
- Select **Sensor Trim** under Trim to recall and select **Next**.
- Follow the screen prompts to recall sensor trim.

5.3.4 Line pressure effect (range 2 and 3)

The following specifications show the static pressure effect for the Rosemount 3051 Range 2 and 3 Pressure Transmitters used in differential pressure applications where line pressure exceeds 2000 psi (138 bar).

Zero effect

± 0.1% of the upper range limit plus an additional ± 0.1% of upper range limit error for each 1000 psi (69 bar) of line pressure above 2000 psi (138 bar).

Example: Line pressure is 3000 psi (207 bar) for ultra performance transmitter. Zero effect error calculation:

$$\pm \{0.05 + 0.1 \times [3 \text{ kpsi} - 2 \text{ kpsi}]\} = \pm 0.15\% \text{ of the upper range limit}$$

Span effect

Refer to Line pressure effect per 1000 psi section of [Rosemount 3051 Pressure Transmitter PDS](#).

5.3.5 Compensating for line pressure (range 4 and 5)

The Rosemount 3051 Wireless Range 4 and 5 Transmitters require a special calibration procedure when used in differential pressure applications. The purpose of this procedure is to optimize transmitter performance by reducing the effect of static line pressure in these applications. The Rosemount 3051 Wireless Differential Transmitters (Ranges 1, 2, and 3) do not require this procedure because optimization occurs in the sensor.

Applying high static pressure to the Rosemount 3051 Wireless Range 4 and 5 Transmitters causes a systematic shift in the output. This shift is linear with static pressure; correct it by performing [Sensor trim](#).

The following specifications show the static pressure effect for the Rosemount 3051 Wireless Range 4 and 5 Transmitters used in differential pressure applications:

Zero effect

$\pm 0.1\%$ of the upper range limit per 1000 psi (69 bar) for line pressures from 0 to 2000 psi (0 to 138 bar)

For line pressures above 2000 psi (138 bar), the zero effect error is $\pm 0.2\%$ of the upper range limit plus an additional $\pm 0.2\%$ of upper range limit error for each 1000 psi (69 bar) of line pressure above 2000 psi (138 bar).

Example: Line pressure is 3000 psi (3 kpsi). Zero effect error calculation:

$\pm \{0.2 + 0.2 \times [3 \text{ kpsi} - 2 \text{ kpsi}]\} = \pm 0.4\%$ of the upper range limit

Span effect

Correctable to $\pm 0.2\%$ of reading per 1000 psi (69 bar) for line pressures from 0 to 3626 psi (0 to 250 bar)

The systematic span shift caused by the application of static line pressure is -1.00% of reading per 1000 psi (69 bar) for Range 4 transmitters, and -1.25% of reading per 1000 psi (69 bar) for Range 5 transmitters.

Use the following example to compute corrected input values.

Span effect example

A transmitter with model number 3051_CD4 will be used in a differential pressure application where the static line pressure is 1200 psi (83 bar). The transmitter output is ranged with 4 mA at 500 inH₂O (1,2 bar) and 20 mA at 1500 inH₂O (3,7 bar).

To correct for systematic error caused by high static line pressure, first use the following formulas to determine corrected values for the low trim and high trim.

$$LT = LRV + S \times (LRV) \times P$$

Where:

LT =	Corrected low trim value
LRV =	Lower range value
S =	-(Span shift per specification)
P =	Static line pressure

$$HT = URV + S \times (URV) \times P$$

Where:

HT =	Corrected high trim value
URV =	Upper range value
S =	-(Span shift per specification)
P =	Static line pressure

In this example.

URV =	1500 inH ₂ O (3.74 bar)
LRV =	500 inH ₂ O (1.25 bar)
P =	1200 psi (82.74 bar)

$$S = \pm 0.01/1000$$

To calculate the low trim (LT) value:

$$LT = 500 + (0.01/1000)(500)(1200)$$

$$LT = 506 \text{ inH}_2\text{O (1.26 bar)}$$

To calculate the high trim (HT) value:

$$HT = 1500 + (0.01/1000)(1500)(1200)$$

$$HT = 1518 \text{ inH}_2\text{O (3.78 bar)}$$

Complete a Rosemount 3051 Wireless sensor trim and enter the corrected values for low trim (LT) and high trim (HT), refer to [Sensor trim](#).

Enter the corrected input values for low trim and high trim through the Communication Device keypad after you apply the nominal value of pressure as the transmitter input.

Note





After sensor trimming Rosemount 3051 Wireless Range 4 and 5 Transmitters for high differential pressure applications, verify the lower and upper operating points are at nominal values using the Communication Device.

5.4 LCD display screen messages

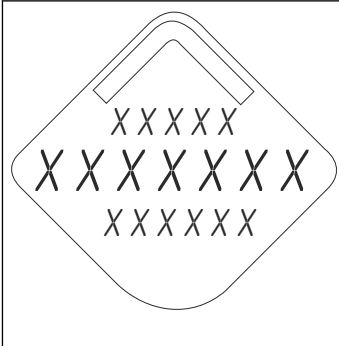
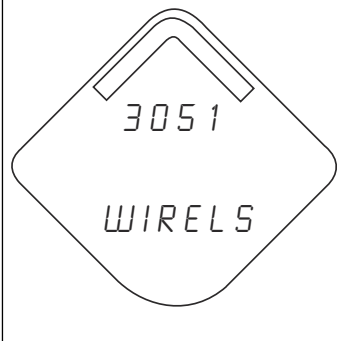
5.4.1 Startup screen sequence

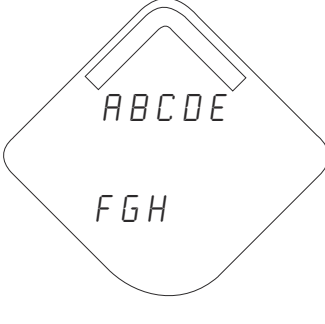
The following screens will display when the power module is first connected to the Rosemount 3051 Wireless.

	<p>All Segments On: Used to visually determine if there are any bad segments on the LCD display.</p>
	<p>Device Identification: Used to determine Device Type.</p>

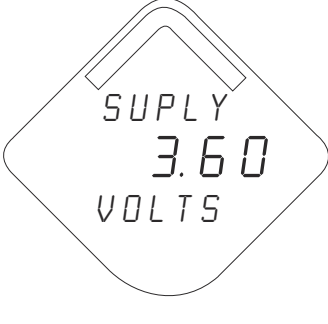
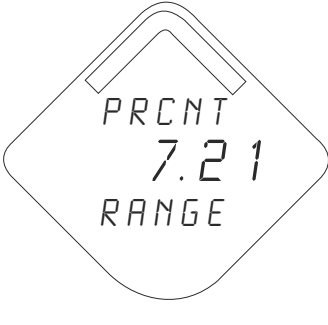
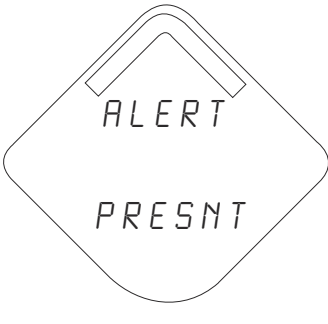

	Device Information - Tag: User entered tag which is eight characters long - will not display if all characters are blank
	PV Screen - process pressure value
	SV Screen - sensor temperature value
	TV Screen - device temperature value

	<p>QV Screen - voltage reading at the power supply terminals</p>
	<p>Percent Range Screen - percent range reading</p>
	<p>Alert Screen - at least one alert is present - this screen will not display if no alerts are present</p>

5.4.2 Diagnostic button screen sequence

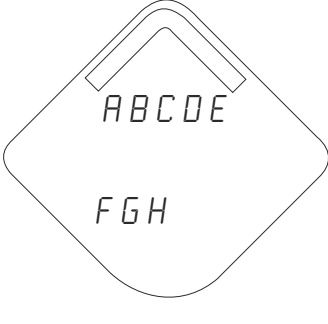
The following five screens will display when the device is operating properly and the Diagnostic Button has been pressed.

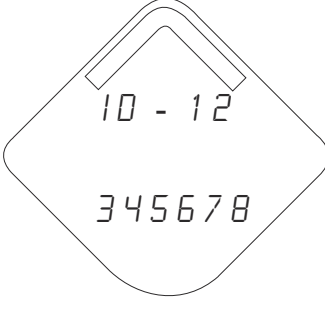

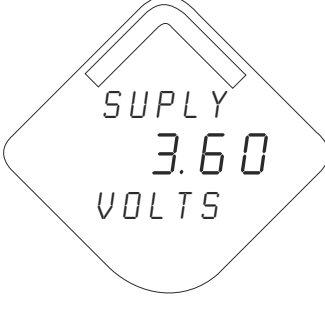

	<p>Device Information - Tag: User entered tag which is eight characters long - will not display if all characters are blank</p>
---	---

	Device Identification: Used to determine Device ID
	Diagnostic Button Screen 3: Assuming the device has the correct join key, this ID tells the user what network the device can connect with
	Diagnostic Button Screen 4: The device has joined a network and has been fully configured and has multiple parents
	Diagnostic Button Screen 5: Voltage reading at the power supply terminals

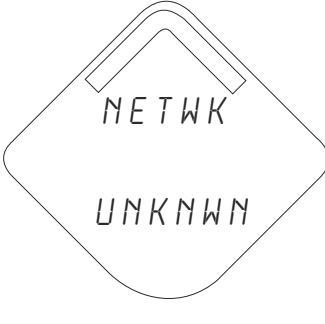
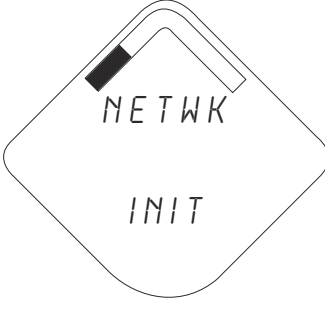
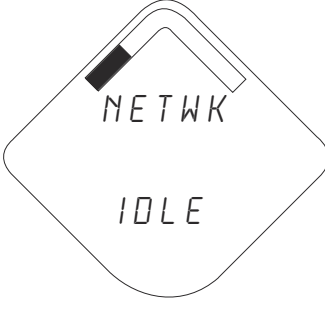
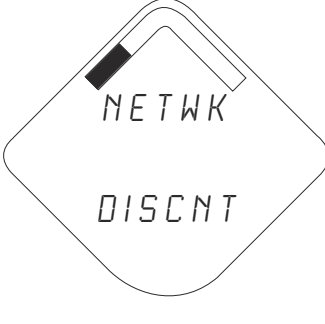
5.4.3 Network diagnostic status screens

These screens display the network status of the device. Only one will be shown during the startup sequence or diagnostic sequence.



	<p>Diagnostic Button Screen 4.1: The device is attempting to start the radio</p>
	<p>Diagnostic Button Screen 4.2: The device has just restarted</p>
	<p>Diagnostic Button Screen 4.3: The device is starting to join the process</p>
	<p>Diagnostic Button Screen 4.4: The device is in a disconnected state and requires a Force Join command to join the network</p>

	<p>Diagnostic Button Screen 4.5: The device is searching for the Network</p>
	<p>Diagnostic Button Screen 4.6: The device is attempting to join a network</p>
	<p>Diagnostic Button Screen 4.7: The device is connected to the Network, but is in a "Quarantined" state</p>
	<p>Diagnostic Button Screen 4.8: The device is joined and operational, but is running with limited bandwidth for sending periodic data</p>

	<p>Diagnostic Button Screen 4.9: The device has joined a network and has been fully configured and has multiple parents</p>
---	---

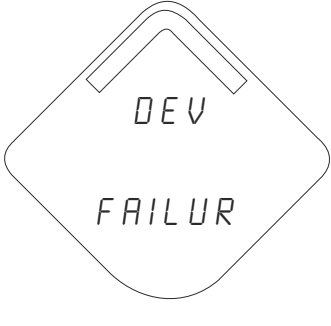

5.4.4 Device Diagnostic screens

The following screens will show the device diagnostics depending on the state of the device.

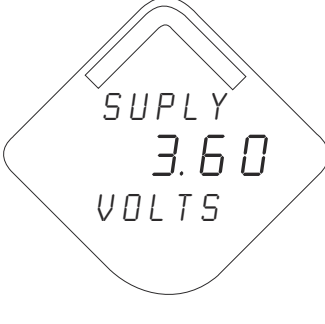
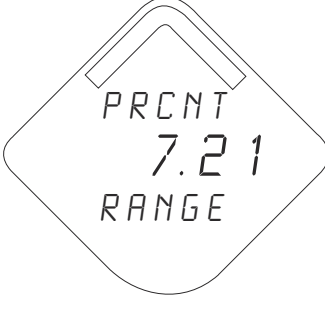
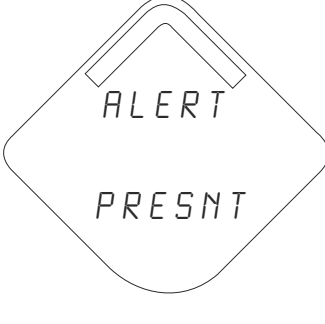
	<p>Device Information - Status: There is a critical error which may prevent the device from operating correctly. Check additional status screens for more information.</p>
	<p>PV Screen - process pressure value</p>
	<p>SV Screen - sensor temperature value</p>

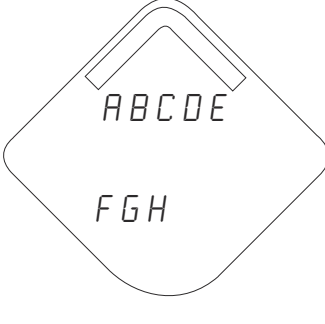
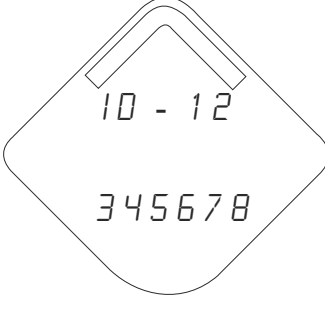
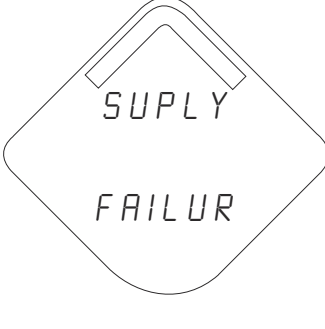
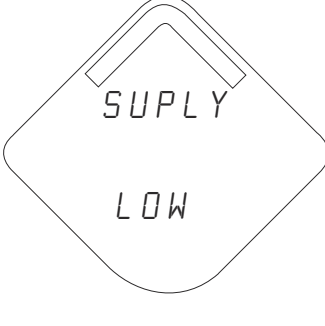
 <p>DEV 25.25 DEG C</p>	<p>TV Screen - device temperature value</p>
 <p>SUPPLY 3.60 VOLTS</p>	<p>QV Screen - voltage reading at the power supply terminals</p>
 <p>PRCNT 7.21 RANGE</p>	<p>Percent Range Screen - percent range reading</p>
 <p>ALERT PRESNT</p>	<p>Alert Screen - at least one alert is present - this screen will not display if no alerts are present</p>

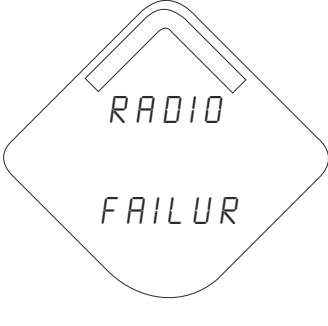
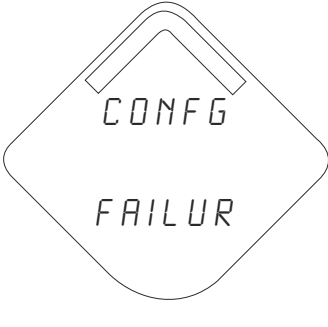
	<p>Diagnostic Button Screen 1 - Tag: User entered tag which is eight characters long - will not display if all characters are blank</p>
	<p>Diagnostic Button Screen 2: The device's identifier that is used to make up the HART long address - the Smart Wireless Gateway may use this to help identify devices if no unique user tag is available</p>
	<p>Diagnostic Button Screen 7.1: The terminal voltage has dropped below level of operating limit. Replace the power module (part number: 701PGNKF)</p>
	<p>Diagnostic Button Screen 7.2: The terminal voltage is below the recommended operating range - the Power Module should be replaced</p>

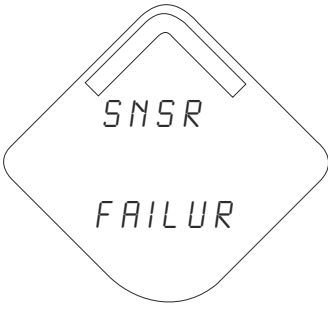
	<p>Diagnostic Button Screen 8: The device may not be able to communicate with the radio or the radio has an internal error. In this state the device may still be operational and publishing HART data</p>
	<p>Diagnostic Button Screen 9.1: Configuration of the transmitter is invalid such that critical operation of the device may be affected - check the extended configuration status to identify which configuration item(s) need to be corrected</p>
	<p>Diagnostic Button Screen 9.2: Configuration of the transmitter is invalid such that non-critical operation of the device may be affected - check the extended configuration status to identify which configuration item(s) need to be corrected</p>
	<p>Diagnostic Button Screen 10.1: A sensor attached to the transmitter has failed, and valid readings from that sensor are no longer possible - check the sensor and sensor wiring connections - check additional status for more detailed information of the failure source</p>

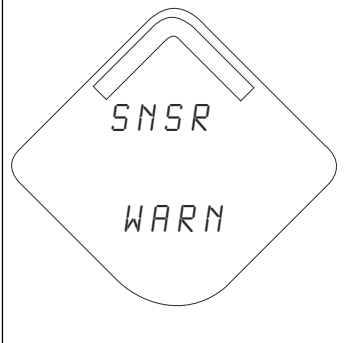
	<p>Diagnostic Button Screen 10.2: A sensor attached to the transmitter is degraded, readings from that sensor may not be within accuracy specifications - check the process, and sensor wiring connections - check additional status for more detailed information of the warning source</p>
---	--

Note

Use the Rosemount Wireless LCD part number: 00753-9004-0002.

6 Troubleshooting

6.1 Overview

This section provides summarized maintenance and troubleshooting suggestions for the most common operating problems for the transmitter and the wireless network connection.

6.2 Electronics failure

An electronics error that could impact the device measurement reading has occurred.

Recommended actions

1. Reset the device.
2. Reconfirm all configuration items in the device.
3. If the condition persists, replace the electronics.

6.3 Radio failure

The wireless radio has detected a failure or stopped communicating.

Recommended actions

1. Reset the device.
2. If the condition persists, replace the electronics.

6.4 Supply voltage failure

The supply voltage is too low for the device to function properly.

Recommended actions

Replace the Power Module.

6.5 Electronics warning

The device detected an electronic error that does not currently impact the device measurement reading.

Recommended actions

1. Reset the device.
2. Reconfirm all configuration items in the device.
3. If the condition persists, replace the electronics.

6.6 Pressure has exceeded limits

The sensor exceeded the maximum measurement range.

Recommended actions

1. Check process for possible saturation condition.
2. Verify the appropriate sensor was chosen for the application.
3. Reconfirm sensor configuration.
4. Reset the device.
5. Replace the sensor.

6.7 Electronics temperature has exceeded limits

The electronics temperature has exceeded the transmitter's maximum range.

Recommended actions

1. Verify the environmental temperature is within the transmitter's range.
2. Remote mount the transmitter away from process and environmental conditions.
3. Reset the device.
4. If the condition persists, replace the electronics.

6.8 Supply voltage low

Cause

The supply voltage is low and may soon affect broadcast updates.

Recommended actions

Replace the power module.

6.9 Database memory warning

Cause

The device failed to write to the database memory. Any data written during this time may have been lost.

Recommended actions

1. Reset the device.
2. Reconfirm all configuration items in the device.
3. If logging dynamic data not needed, this advisory can be safely ignored.
4. If the condition persists, replace the electronics.

6.10 Configuration error

Cause

The device detected a configuration error based on a change to the device.

Recommended actions

1. Click on **Details** for more information.
2. Correct the parameter that has a configuration error.

3. Reset the device.
4. If the condition persists, replace the electronics.

6.11 HI HI alert

Cause

The primary variable surpassed the user-defined limit.

Recommended actions

1. Verify the process variable is within user-specified limits.
2. Reconfirm the user-defined alert limit.
3. If not needed, disable this alert.

6.12 HI alert

Cause

The primary variable surpassed user-defined limit.

Recommended actions

1. Verify the process variable is within user-specified limits.
2. Reconfirm the user-defined alert limit.
3. If not needed, disable this alert.

6.13 LO alert

Cause

The primary variable surpassed the user-defined limit.

Recommended actions

1. Verify the process variable is within user-specified limits.
2. Reconfirm the user-defined alert limit.
3. If not needed, disable this alert.

6.14 LO LO alert

Cause

The primary variable surpassed the user-defined limit.

Recommended actions

1. Verify the process variable is within user-specified limits.
2. Reconfirm the user-defined alert limit.
3. If not needed, disable this alert.

6.15 Button stuck

Cause

A button on the Electronics Board is detected as stuck in the active position.

Recommended actions

1. Inspect the buttons for obstructions. Clear any obstructions found during inspection.
2. Reset the device.
3. If the condition persists, replace the electronics.

6.16 Simulation Active

The device is in **Simulation** mode and may not be reporting actual information.

Recommended actions

1. Verify that simulation is no longer required.
2. Disable **Simulation** mode in **Service Tools**.
3. Reset the device.

6.17 Transmitter will not respond to changes in applied pressure

Recommended actions

1. Check impulse piping or manifold for blockage.
2. Verify applied pressure is between 4 and 20 mA points.
3. Verify the **output** is not in **Alarm** condition.
4. Verify transmitter is not in **Loop Test** mode.
5. Verify transmitter is not in **Multidrop** mode.
6. Check test equipment.

6.18 Digital pressure variable reading is low or high

Recommended actions

1. Check impulse piping for blockage or low fill in wet leg.
2. Verify transmitter is calibrated properly.
3. Check test equipment (verify accuracy).
4. Verify pressure calculations for application.
5. Restore pressure calibration. Go to **Device Settings** → **Calibration** → **Pressure** → **Factory Calibration** → **Restore Pressure Calibration**.

6.19 Digital pressure variable reading is erratic

Recommended actions

1. Check application for faulty equipment in pressure line.
2. Verify transmitter is not reacting directly to equipment turning On/Off.
3. Verify damping is set properly for application.

6.20 LCD display is not functioning

Recommended actions

1. Reseat the LCD according to [Install the LCD display](#).
2. Verify the LCD display is a wireless LCD meter. An LCD from a wired device will not function in a wireless device. Rosemount part number: 00753-9004-0002
3. Verify the LCD display mode is not disabled.

6.21 Device not joining the network

Recommended actions

1. Verify the network ID and join key.
2. Wait 30 minutes.
3. Enable **High Speed Operation** on Smart Wireless Gateway.
4. Inspect the Power Module.
5. Verify the device is within range of at least one other device.
6. Verify the network is in active network advertise.
7. Power Cycle the device to try again.
8. Verify the device is configured to join. Send the **Force Join** command to the device.
9. See troubleshooting section of Smart Wireless Gateway for more information.

6.22 Short battery life

Recommended actions

1. Verify **Power Always On** mode is off.
2. Verify the device is not installed in extreme temperatures.
3. Verify the device is not a network pinch point.
4. Check for excessive network rejoins due to poor connectivity.

6.23 Limited bandwidth error

Recommended actions

1. Reduce the **Update Rate** on transmitter.
2. Increase communication paths by adding more wireless points.
3. Verify the device has been online for at least one hour.

4. Verify the device is not routing through a "limited" routing node.
5. Create a new network with an additional Smart Wireless Gateway.

6.24 Removing from service

Follow these steps:

Procedure

1. Follow all plant safety rules and procedures.
2. Isolate and vent the process from the transmitter before removing the transmitter from service.
3. Remove the transmitter from the process connection.
 - a) The Rosemount 3051C Wireless Transmitter is attached to the process connection by four bolts and two cap screws. Remove the bolts and screws and separate the transmitter from the process connection. Leave the process connection in place and ready for re-installation. Reference [Figure 3-5](#) for coplanar flange.
 - b) The Rosemount 3051T Wireless Transmitter is attached to the process by a single hex nut process connection. Loosen the hex nut to separate the transmitter from the process. Do not wrench on neck of transmitter.

⚠ WARNING

Do not apply torque directly to the sensor module. Rotation between the sensor module and the process connection can damage the electronics. To avoid damage, apply torque only to the hex-shaped process connection.

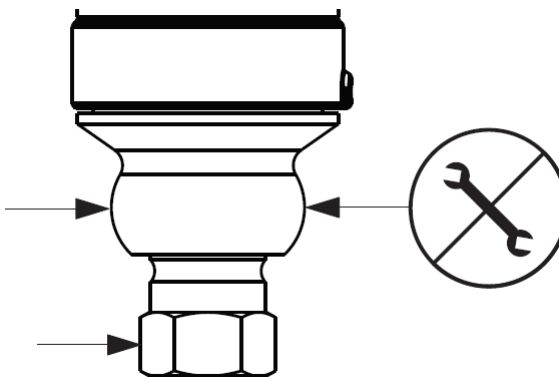

4. Do not scratch, puncture, or depress the isolating diaphragms.
5. Clean isolating diaphragms with a soft rag and a mild cleaning solution, and rinse with clear water.
6. Whenever you remove the process flange or flange adapters, visually inspect the PTFE O-rings. Replace the O-rings if they show any signs of damage, such as nicks or cuts. Undamaged O-rings may be reused.

7 Reference Data

7.1 Ordering information, specifications, and drawing

To view current Rosemount™ 3051 Wireless Pressure Transmitters ordering information, specifications, and drawings:

Procedure

1. Go to the [Rosemount 3051 Wireless Pressure Transmitters](#).
2. Scroll as needed to the green menu bar and click **Documents & Drawings**.
3. For installation drawings, click **Drawings & Schematics** and select the appropriate document.
4. For ordering information, specifications, and dimensional drawings, click **Data Sheet & Bulletins** and select the appropriate Product Data Sheet.

7.2 Product certifications

To view current Rosemount 3051 product certifications, see the [Rosemount 3051 Quick Start Guide](#).

A Network Design Best Practices

All recommended practices should be followed to ensure highest data reliability. Deviation from these best practices may require device repeaters in the network to maintain 99% data. The following are guidelines to achieve the best possible Smart Wireless reliability Network.

1. Each wireless network field should be scoped to a single process unit.
2. Minimize the number of hops to the Gateway in order to reduce latency. A minimum of five wireless instruments should be within effective range of the Smart Wireless Gateway.
3. Each device in the network should have at minimum three devices with potential communication paths. A mesh network gets its reliability from multiple communication pathways. Ensuring each device has multiple neighbors within range will result in the most reliable network.
4. Have 25 percent of wireless instruments in the network within range of Smart Wireless Gateway. Other enhancing modifications include creating a higher percentage of devices within effective range of the gateway to 35 percent or more. This clusters more devices around the gateway and ensures fewer hops and more bandwidth available to WirelessHART devices with fast scan rates.
5. Effective range is determined by type of process unit and the density of the infrastructure that surrounds the network.

A.1 Effective range

Heavy obstruction: 100 ft. (30 m). Typical heavy density plant environment. Cannot drive a truck or equipment through. Medium obstruction: 250 ft. (76 m). Typical light process areas, lots of space between equipment and infrastructure. Light obstruction: 500 ft. (152 m). Typical of tank farms. Despite tanks being big obstructions themselves, lots of space between and above makes for good RF propagation. Line of sight: 750 ft. (230 m). No obstructions between *WirelessHART*[®] devices and devices mounted a minimum of 6 ft. (2 m) above ground or obstructions.

For examples and complete explanations, refer to the IEC62591 *WirelessHART* System [Engineering Guide](#).

B Communication Device Menu Trees and Fast Keys

B.1 Communication Device menu tree

Figure B-1: Overview

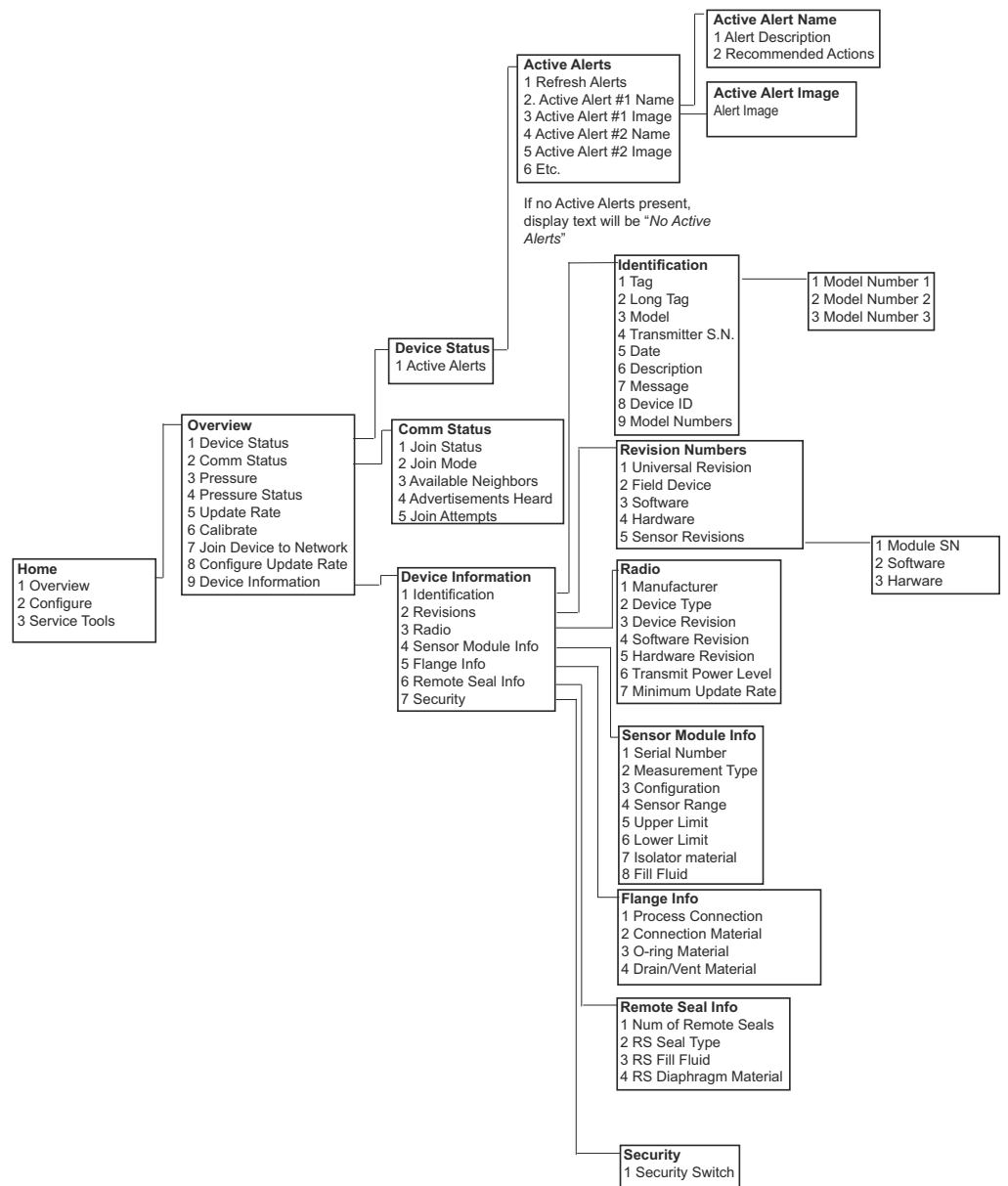

Figure B-2: Configure

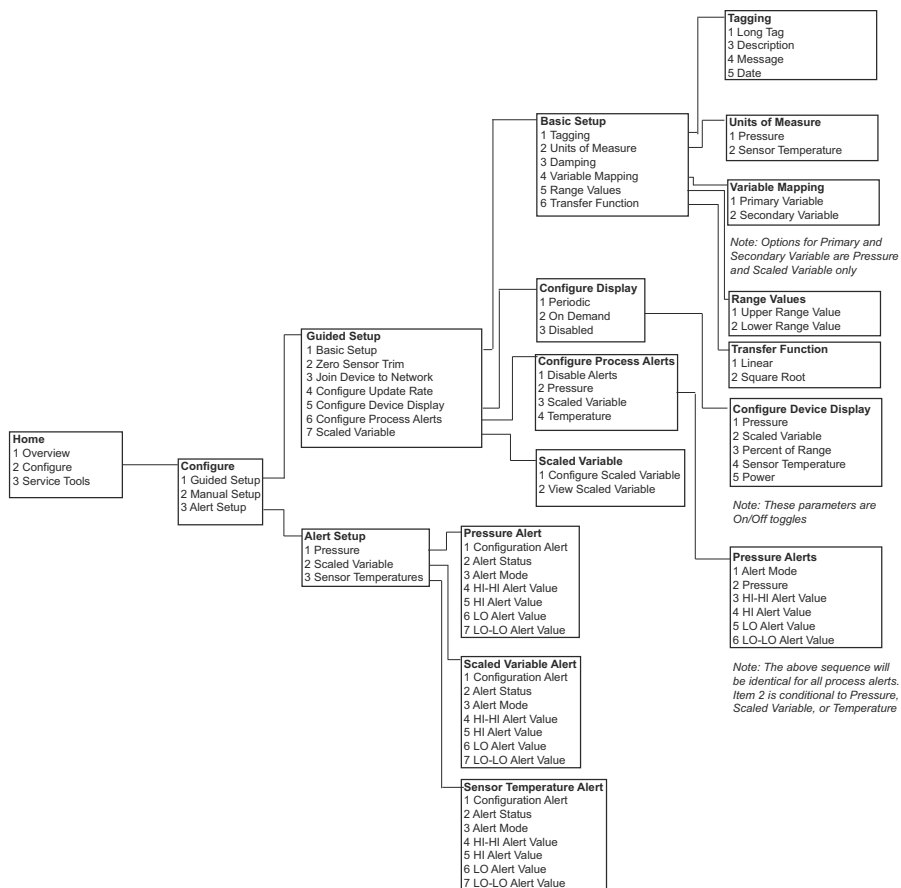

Figure B-3: Service Tools

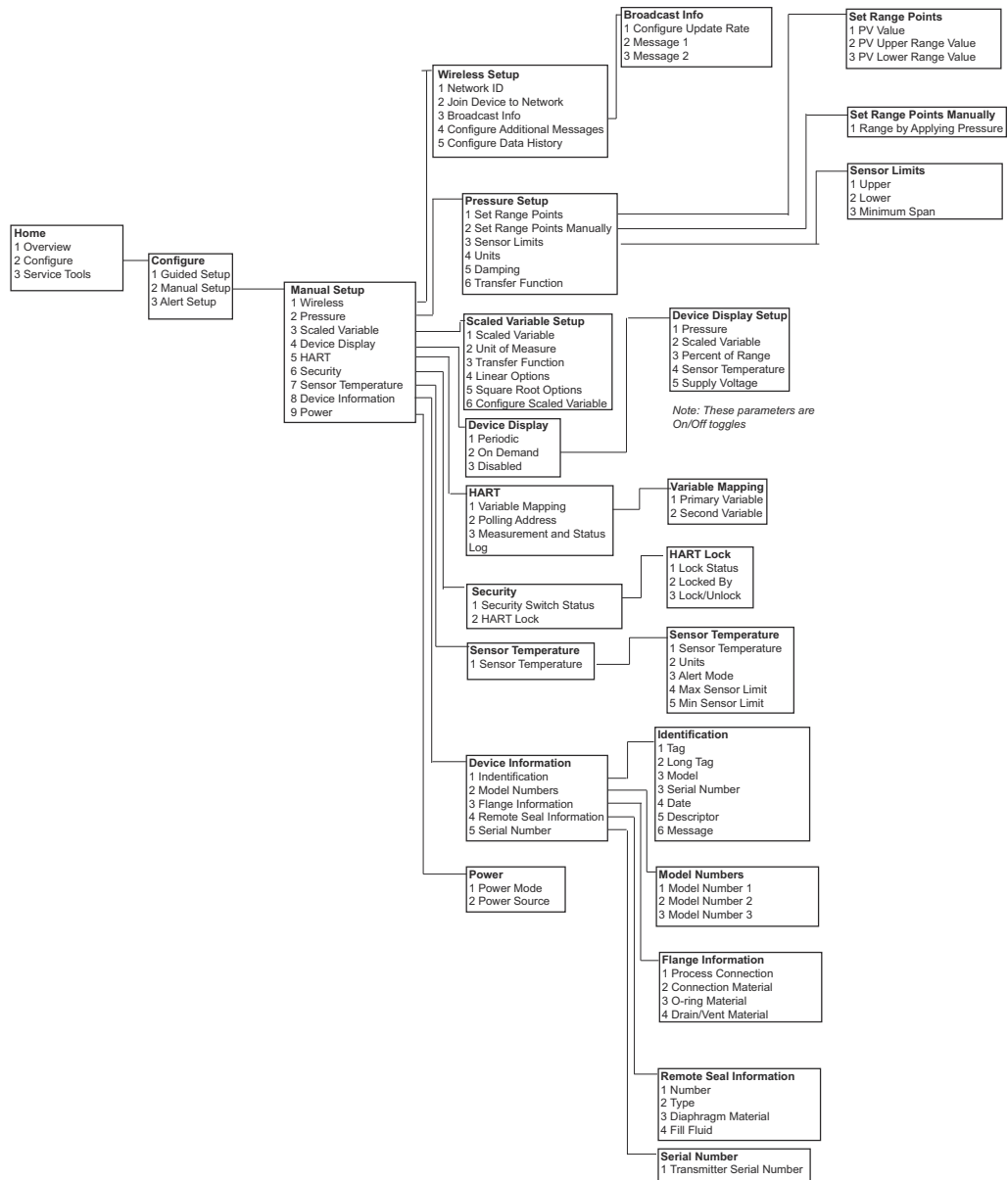
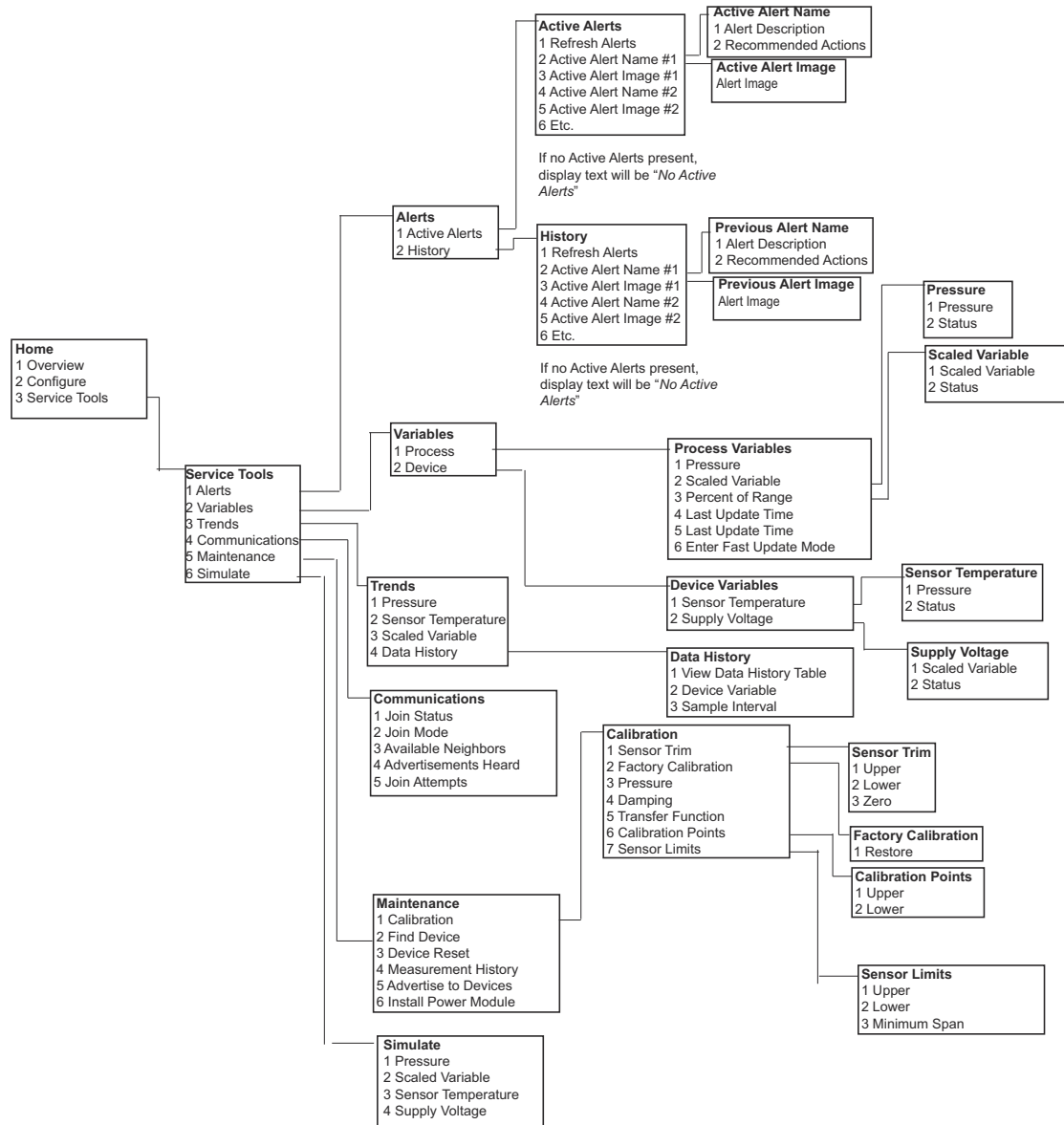

Figure B-4: Rosemount 3051 Communication Device Menu Tree: Manual Setup



B.2 Communication Device Fast Keys

- A (✓) indicates the basic configuration parameters. At minimum these parameters should be verified as a part of configuration and startup.
- A (7) indicates availability only in HART revision 7 mode.

Table B-1: Device Revision 9 and 10 (HART7), DD Revision 1 Fast Key sequence

	Function	Fast Key Sequence	
		HART 7	HART 5
✓	Alarm and Saturation Levels	2, 2, 2, 5	2, 2, 2, 5

**Table B-1: Device Revision 9 and 10 (HART7), DD Revision 1 Fast Key sequence
(continued)**

	Function	Fast Key Sequence	
		HART 7	HART 5
✓	Damping	2, 2, 1, 1, 5	2, 2, 1, 1, 5
✓	Primary Variable	2, 2, 5, 1, 1	2, 2, 5, 1, 1
✓	Range Values	2, 2, 2, 1	2, 2, 2, 1
✓	Tag	2, 2, 7, 1, 1	2, 2, 7, 1, 1
✓	Transfer Function	2, 2, 1, 1, 6	2, 2, 1, 1, 6
✓	Pressure Units	2, 2, 1, 1, 4	2, 2, 1, 1, 4
	Date	2, 2, 7, 1, 5	2, 2, 7, 1, 4
	Descriptor	2, 2, 7, 1, 6	2, 2, 7, 1, 5
	Digital to Analog Trim (4–20 mA Output)	3, 4, 2, 1	3, 4, 2, 1
	Digital Zero Trim	3, 4, 1, 3	3, 4, 1, 3
	Display Configuration	2, 2, 4	2, 2, 4
	LOI Password Protection	2, 2, 6, 5	2, 2, 6, 4
	Loop Test	3, 5, 1	3, 5, 1
	Lower Sensor Trim	3, 4, 1, 2	3, 4, 1, 2
	Message	2, 2, 7, 1, 7	2, 2, 7, 1, 6
	Pressure Trend	3, 3, 1	3, 3, 1
	Rerange with Keypad	2, 2, 2, 1	2, 2, 2, 1
	Scaled D/A Trim (4–20 mA Output)	3, 4, 2, 2	3, 4, 2, 2
	Scaled Variable	2, 2, 3	2, 2, 3
	Sensor Temperature Trend	3, 3, 3	3, 3, 3
	Switch HART Revision	2, 2, 5, 2, 4	2, 2, 5, 2, 3
	Upper Sensor Trim	3, 4, 1, 1	3, 4, 1, 1
7	Long Tag	2, 2, 7, 1, 2	N/A
7	Locate Device	3, 4, 5	N/A
7	Simulate Digital Signal	3, 5	N/A

For more information: [Emerson.com/global](https://emerson.com/global)

©2024 Emerson. All rights reserved.

Emerson Terms and Conditions of Sale are available upon request. The Emerson logo is a trademark and service mark of Emerson Electric Co. Rosemount is a mark of one of the Emerson family of companies. All other marks are the property of their respective owners.

