

Rosemount™ CT4215 Leak Detection System



Preface

Published by Emerson.

All possible care has been taken in the preparation of this publication, but Emerson and its agents and distributors accept no liability for any inaccuracies that may be found.

Emerson reserves the right to make changes without notice both to this publication and the products which it describes.

No part of this publication may be reproduced, stored in a retrieval system, or transmitted in any form or by any means electronic, mechanical, photocopying, recording, or otherwise without the express prior written permission of the copyright holder.

If you require further assistance or technical support, contact your local Emerson distribution partner or cascade.support@emerson.com.

Send general inquiries to cascade.support@emerson.com.

Important information

Important

Users must read, understand, and comply with the following information before proceeding.

All users, installers, operators, and maintainers must be familiar with operating the leak detection system. To install, start up, operate, maintain, and service the leak detector in a safe manner, it is **MANDATORY** to read all additional instruction manuals shipped with the unit.

User information

Important

All users must read this page before proceeding!

Emerson designs, manufactures, and tests its products to meet national and international standards. To ensure the product, continues to operate as designed and within normal specifications, it **MUST** be installed, used, and maintained correctly.

The following instructions **MUST** be adhered to and integrated into your safety program when installing, operating, and maintaining the leak detector

- Failure to follow the proper instructions may cause:
 - Loss of life
 - Personal injury
 - Damage to property
 - Damage to this instrument
 - Warranty invalidation
- Read all instructions prior to installing, operating, and servicing the product.
- If you do not understand the instructions, contact cascade.support@emerson.com for additional clarification.
- Follow all warnings, cautions, and instructions marked on and supplied with the product.
- Inform and educate your personnel in the proper installation, operation, and maintenance of the product.
- Install your equipment as specified in the installation instructions of the appropriate manual and in accordance with applicable local and national codes.
- Connect all products to the correct electrical and pressure sources.
- To ensure proper performance, use qualified personnel to install, operate, update, program, and maintain the product.
- When replacement parts are required, ensure that qualified people use **ONLY** parts specified and supplied by Emerson.
- Unauthorized parts and procedures can affect the product's performance, place the safe operation of your process at risk, and **VOID YOUR WARRANTY**. Look-alike substitutions may result in fire, electrical hazards, or improper operation.
- To prevent electrical shock and personal injury, all equipment doors must be closed and protective covers in place, except when maintenance is being performed by qualified personnel.
- The information contained in this document is subject to change without notice.

General safety notice/residual risk

Installation, operation, and maintenance of the leak detection system must be in accordance with these instructions.

Authorized personnel

Personnel installing, operating, servicing, and maintaining the leak detection system must be instructed, trained and qualified with the operating company and the manufacturer.

It is the operating company's responsibility to:

- Train staff
- Observe safety regulations
- Follow the safety instructions and procedures in the product manual

Operators must:

- Be trained and competent.
- Read and understand all relevant sections of the product manual before commencing work
- Know the safety mechanisms and regulations

Regulations and standards

Regulation/standards	Description
IEC 60825-1:2014 Ed 3	Safety of laser products - Part 1: Equipment classification and requirements.
IEC 61010-1:2010 +AMD1:2016 CSV UL Std.No. 61010-1 (3rd edition)	Safety requirements for electrical equipment for measurement, control, and laboratory use - Part 1: General requirements.
IEC 61326-1: 2020	Electrical equipment for measurement, control and laboratory use - EMC requirements - Part 1: General requirements.
2012/19/EU	Waste Electrical and Electronic Equipment (WEEE) Directive.
2014/30/EU	The Electromagnetic Compatibility Directive.
2014/35/EU	The Low Voltage Directive.
FDA 21 CFR 1040.10	Performance standards for light-emitting products – Sec. 10 :Laser products.
NFPA 70 (2021)	National Electrical Code (issued by ANSI: American National Standards Institute and NFPA 70: National Fire Protection Association).

Compliance approvals

Important

The analyzer is designed for use in Non Hazardous areas ONLY.



This product is designed and manufactured under an approved quality management system to ISO 9001: 2015.



Emerson have satisfied the requirements for applying the CE and UKCA marking to this product. This equipment meets all requirements of the EMC and Low Voltage directives.

Waste disposal



Do not dispose of in household waste.

Only for EC countries:

In accordance with European Directive 2012/19/EU for Waste Electrical and Electronic Equipment and its implementation into national right, measuring tools that are no longer usable must be collected separately and disposed of in an environmentally correct manner.

In accordance with the European Directive 2012/19/EU for Waste Electrical and Electronic Equipment (WEEE) disposal of the leak detection system when no longer serviceable must be collected separately and disposed of in an environmentally correct manner.

Hazard messages

This document uses the following criteria for hazard messages based on ANSI standards Z535.6-2011 (R2017).

⚠ DANGER

Serious injury or death will occur if a hazardous situation is not avoided.

⚠ WARNING

Serious injury or death could occur if a hazardous situation is not avoided.

⚠ CAUTION

Minor or moderate injury will or could occur if a hazardous situation is not avoided.

NOTICE

Data loss, property damage, hardware damage, or software damage can occur if a situation is not avoided. There is no credible risk of physical injury.

Physical access

NOTICE

Unauthorized personnel can potentially cause significant damage and/or misconfiguration of end users' equipment. Protect against all intentional or unintentional unauthorized use.

Physical security is an important part of any security program and fundamental to protecting your system. Restrict physical access to protect users' assets. This is true for all systems used within the facility.

Safety precautions

The precautions in this manual MUST NOT be changed amended or removed. All authorized users, installation, operation and maintenance personnel, must observe the safety precautions and warnings.

The analyzer is **NOT** designed for use in Hazardous areas.

⚠ DANGER

ELECTRIC SHOCK

Serious injury or death will occur.

The leak detection system operates using mains voltage and must be switched off and the power cable removed before opening the analyzer.

⚠ WARNING

HEAVY ITEM

Serious injury or death could occur.

The leak detection system weighs 119 kg (263 lb) and should only be moved by a minimum of two people using suitably rated lifting/moving equipment .

To prevent crushing of hands, feet, or other body parts always wear suitable protective gloves and footwear when handling.

The selected installation site must be suitable to support the weight of the leak detection system, cabling and gas sample lines when installed.

⚠ WARNING

HIGH PRESSURE AIR

Serious injury or death could occur.

The compressed air supply operate at pressures that can cause injury.

⚠ WARNING

HAZARD BY WRONG SUPPLY VOLTAGE

Serious injury or death could occur.

The rated voltage for the leak detector is fixed during the manufacture and defined on the ratings label fitted to the unit.

The voltage at the installation site must meet the rated voltage required.

⚠ WARNING

MAINTENANCE

Serious injury or death could occur.

Only authorized maintenance personnel can carry out repair work on the leak detection system.

On completion verify:

- All tools and equipment are removed.

- No contamination (water/dust) is in the compartments.

- Leak detector is wiped clean.

- Vents are clear and free from obstruction.

- Verify that system is in a safe state for operation.

⚠ CAUTION

LASER / OPTICAL PATH

Minor or moderate injury will or could occur

Operators do not have access to the internal laser or electrics during normal operation.

Maintenance personnel must only access the internal laser or electrics after the analyzer has been turned off.

Opening the leak detection system and attempting to perform adjustments other than those specified in this manual may result in Class 3R optical radiation exposure. Do not look at the laser with any kind of magnifier or optical measuring device.

Use of controls or adjustments or performance of procedures other than those specified herein may result in hazardous radiation exposure.

⚠ CAUTION

EQUIPMENT DAMAGE

Minor or moderate injury will or could occur

Always follow the procedures detailed in the manual otherwise damage to the leak detector may result.

Only authorized personnel can operate the leak detection system.

Do not operate the leak detection system unless it is physically secured in position and all electrical and sample gas connections are in place.

⚠ CAUTION

AIR SUPPLY

Minor or moderate injury will or could occur



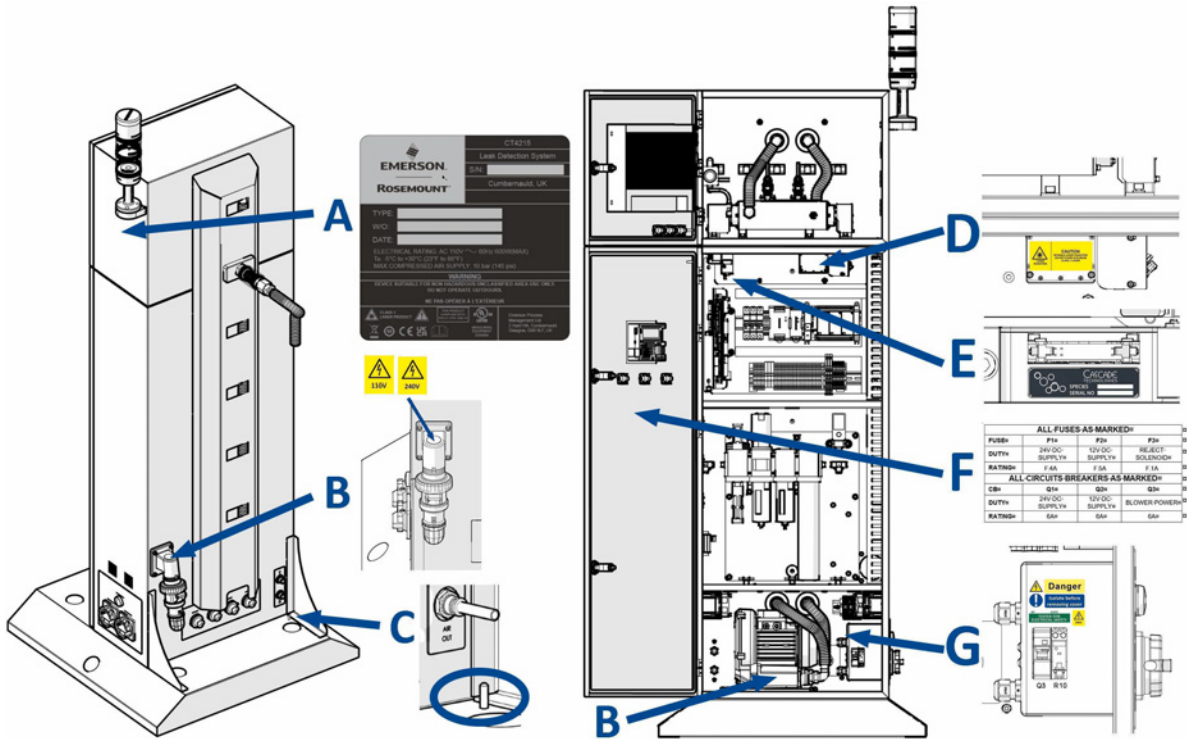

Air provided must be connected from a pressure regulated clean, filtered and moisture free supply source.

Safety and system labels and annotation

Labels are applied to the analyzer in the positions shown below.

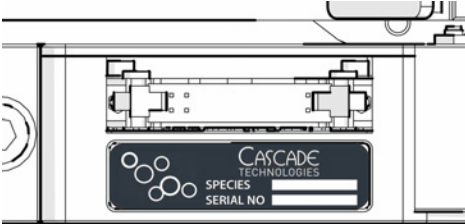

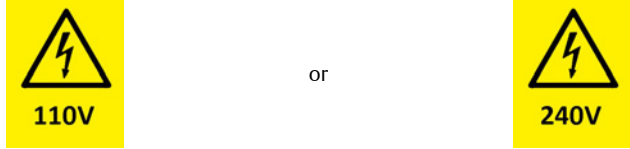
Location	Label Type	Label fitted		
A	Identification label (including the Serial No. (S/N), Model No. and Date of Manufacture (DoM)).		or	
B	AC Supply Voltage		or	
C	Chassis earth terminal location	N/A		
D	Laser radiation CAUTION label			

Location	Label Type	Label fitted																																
E	Laser module identification label																																	
F	Fuse and circuit breaker identification label.	<table border="1" data-bbox="755 577 1347 871"> <thead> <tr> <th colspan="4">ALL FUSES AS MARKED</th> </tr> <tr> <th>FUSE</th> <th>F1</th> <th>F2</th> <th>F3</th> </tr> </thead> <tbody> <tr> <td>DUTY</td> <td>24V DC SUPPLY</td> <td>12V DC SUPPLY</td> <td>REJECT SOLENOID</td> </tr> <tr> <td>RATING</td> <td>4 A Eaton GMA-4-R</td> <td>5 A Eaton GMA-5-R</td> <td>1 A Eaton GMA-1-R</td> </tr> <tr> <th colspan="4">ALL CIRCUITS BREAKERS AS MARKED</th> </tr> <tr> <th>CB</th> <th>Q1</th> <th>Q2</th> <th>Q3</th> </tr> <tr> <td>DUTY</td> <td>24V DC SUPPLY</td> <td>12V DC SUPPLY</td> <td>BLOWER POWER</td> </tr> <tr> <td>RATING</td> <td>6A</td> <td>6A</td> <td>6A</td> </tr> </tbody> </table>	ALL FUSES AS MARKED				FUSE	F1	F2	F3	DUTY	24V DC SUPPLY	12V DC SUPPLY	REJECT SOLENOID	RATING	4 A Eaton GMA-4-R	5 A Eaton GMA-5-R	1 A Eaton GMA-1-R	ALL CIRCUITS BREAKERS AS MARKED				CB	Q1	Q2	Q3	DUTY	24V DC SUPPLY	12V DC SUPPLY	BLOWER POWER	RATING	6A	6A	6A
ALL FUSES AS MARKED																																		
FUSE	F1	F2	F3																															
DUTY	24V DC SUPPLY	12V DC SUPPLY	REJECT SOLENOID																															
RATING	4 A Eaton GMA-4-R	5 A Eaton GMA-5-R	1 A Eaton GMA-1-R																															
ALL CIRCUITS BREAKERS AS MARKED																																		
CB	Q1	Q2	Q3																															
DUTY	24V DC SUPPLY	12V DC SUPPLY	BLOWER POWER																															
RATING	6A	6A	6A																															
G	Isolate before removing cover DANGER Label																																	
	AC Supply Voltage																																	
	Electrical safety label.																																	

Contents

Chapter 1	Leak detection overview.....	13
	1.1 System overview.....	13
Chapter 2	Equipment and accessories.....	15
	2.1 Upper and lower enclosures.....	15
	2.2 Main operating controls and displays	16
	2.3 Analysis cell and purge.....	17
	2.4 Electrical back plate.....	18
	2.5 Air preparation plate.....	20
	2.6 Blower and electrical shut off.....	21
	2.7 Leak detector interface connections.....	22
	2.8 Leak detector installed examples.....	24
	2.9 Sample head types.....	25
Chapter 3	Installation.....	27
	3.1 Site selection.....	27
	3.2 Unpacking.....	29
	3.3 Installing the leak detector.....	33
	3.4 Electrical, signal, compressed air in and sample gas connection details.....	38
Chapter 4	Start-up procedure.....	43
Chapter 5	Shut down procedure.....	47
Chapter 6	Software interface description.....	49
	6.1 Leak detector manager.....	49
	6.2 Data logging and reporting.....	59
	6.3 Status lamps / errors.....	62
	6.4 Status.....	64
	6.5 PLC configuration.....	64
Chapter 7	Maintaining the leak detector.....	77
	7.1 Scheduled maintenance.....	77
	7.2 Purging the analysis cell.....	77
	7.3 Cleaning the cell mirrors.....	78
	7.4 Replace the sample gas inlet filter.....	82
	7.5 Replacing a fuse.....	83
Chapter 8	Troubleshooting and diagnostics.....	87
Appendix A	Specification.....	93

1 Leak detection overview

The CT4215 Leak Detection System, hereafter referred to as CT4215 or the leak detector, is an electronic sensor that uses laser spectroscopy to identify gasses used in the food and beverage industries as product is carried along a conveyor belt at high speed.

The function of the leak detector is to identify micro leakages from Modified Atmosphere Packages (MAP). The leak detector uses a Laser calibrated to measure the gas within the modified atmosphere, e.g. CO₂, N₂O or Ethanol, to identify leaking packages. The leak detection system is installed together with a custom sampling head designed for the product range and a where required a reject mechanism to remove the defective goods from the production line.

This document is intended for the personnel who install, operate, and maintain the leak detector.

1.1 System overview

The leak detector can be installed along side existing production lines and comprises an all metal stainless steel enclosure containing the analyzer, PLC control system, compressed air and vacuum gas sample handling systems.

Depending on the product line being monitored by the leak detector additional systems can be added as follows.

1. Sample Head suitable for the product line being monitored.
2. Input Gates used to count product into and out of system.
3. Rejector to remove defective product from the production line .

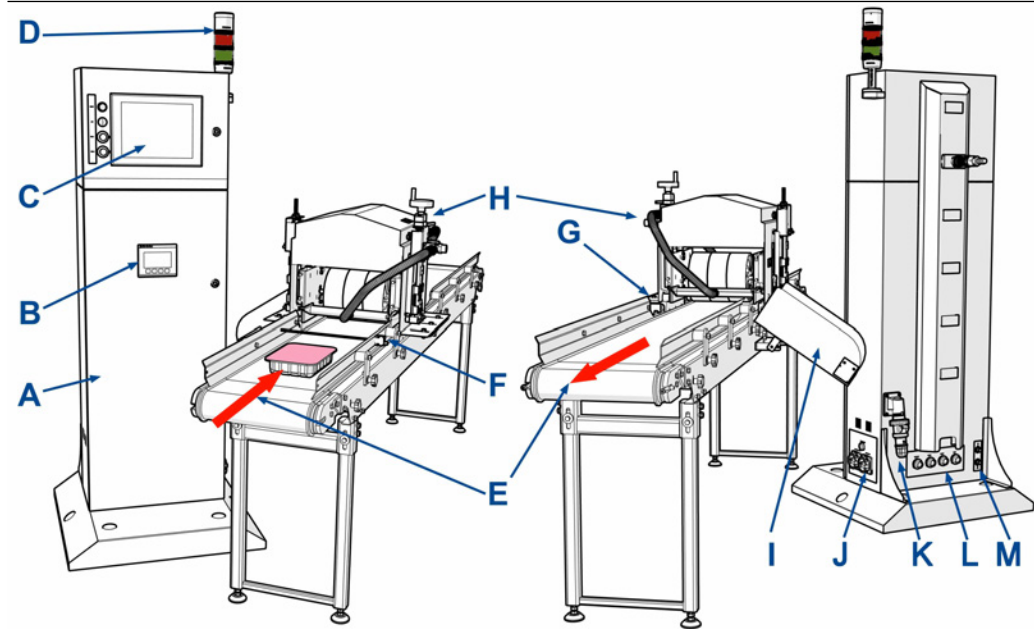

- A. Leak detector system.
- B. PLC display screen.
- C. HMI touch screen.
- D. Status beacon.
- E. Product line direction.
- F. Input gate.
- G. Rejector.
- H. Sample head.
- I. Reject chute (Collection bin customer supplied).
- J. Circuit breakers.
- K. AC supply.
- L. Customer connections.
- M. Compressed air line connections.

2 Equipment and accessories

2.1 Upper and lower enclosures

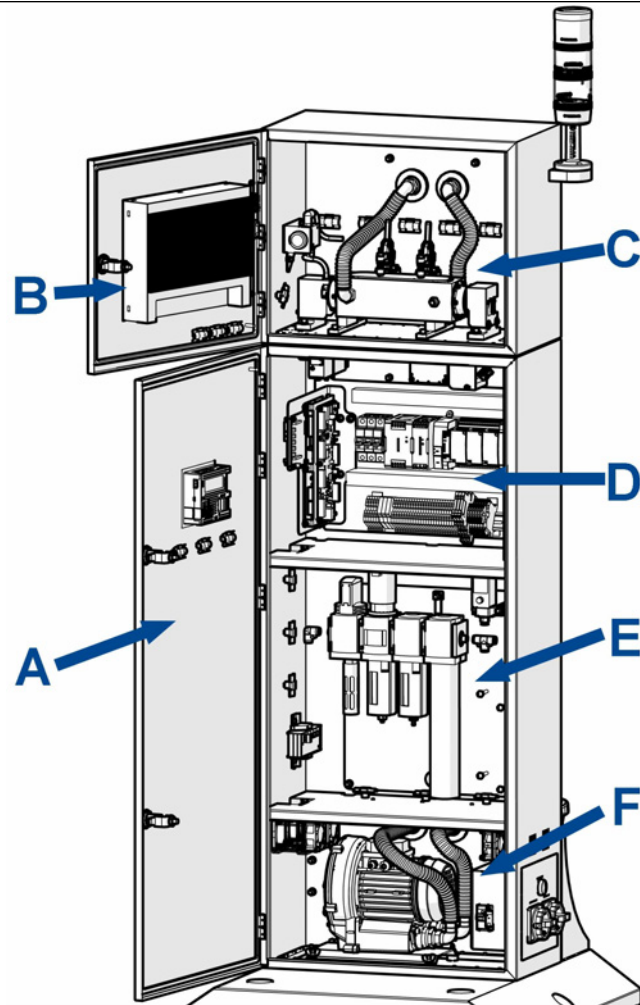

- A. Lower enclosure door with PLC control panel fitted.
- B. Upper enclosure door with HMI panel LED and reset buttons.
- C. Upper enclosure fitted with the analysis cell and cell purge.
- D. 1st compartment fitted with the electrical back plate and electronics panel.
- E. 2nd compartment fitted with the air preparation panel.
- F. 3rd compartment fitted with the sample air motor and electrical shut off.

2.2 Main operating controls and displays

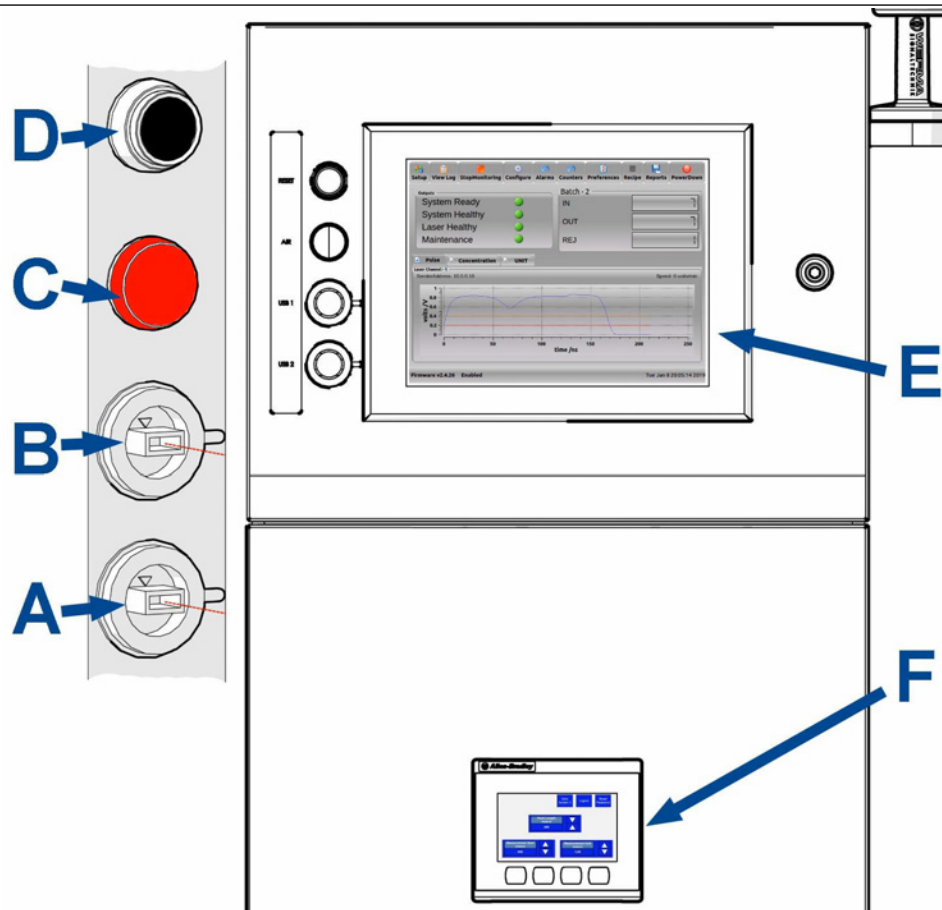

- A. USB port 2.
- B. USB port 1.
- C. Air fault indicator.
- D. Reset button.
- E. Main HMI display screen.
- F. PLC screen.

2.3 Analysis cell and purge

The assembly shown is mounted in the upper enclosure.

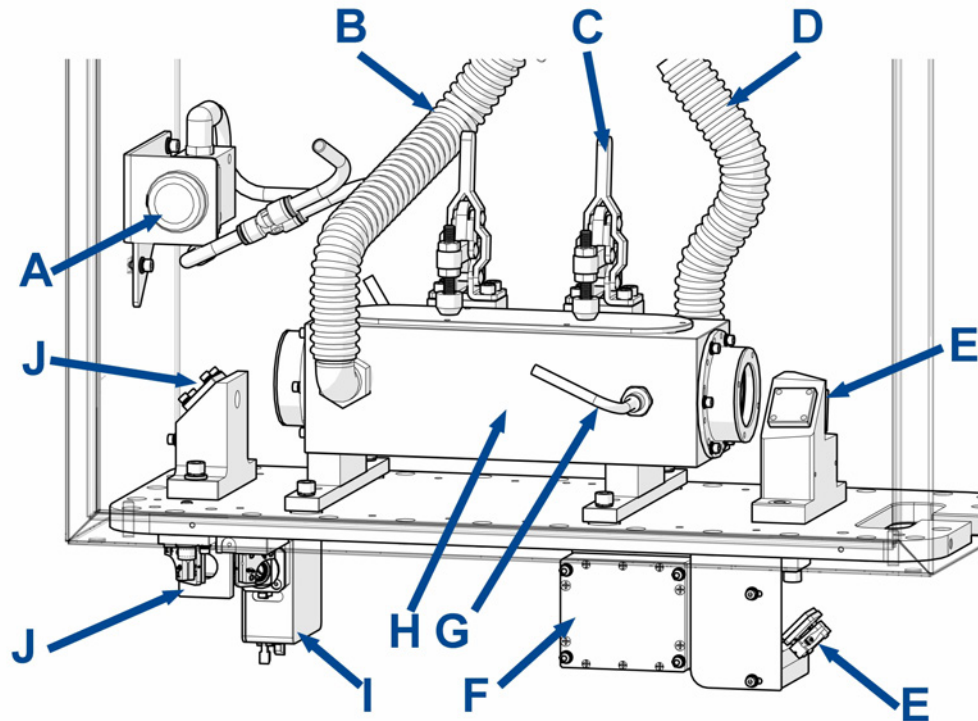

- A. Manual purge button.
- B. Gas sample inlet from the production line.
- C. Toggle clamp.
- D. Gas sample outlet connected to the blower motor.
- E. Cell output mirrors, directing the laser beam from the cell into the detector.
- F. Detector.
- G. One of two purge connections for the output mirrors inside the cell.
- H. Sample gas analysis cell.
- I. Laser module.
- J. Cell input mirrors, directing the laser beam into the cell.

2.4 Electrical back plate

The assembly shown is mounted in the 1st compartment of the lower enclosure.

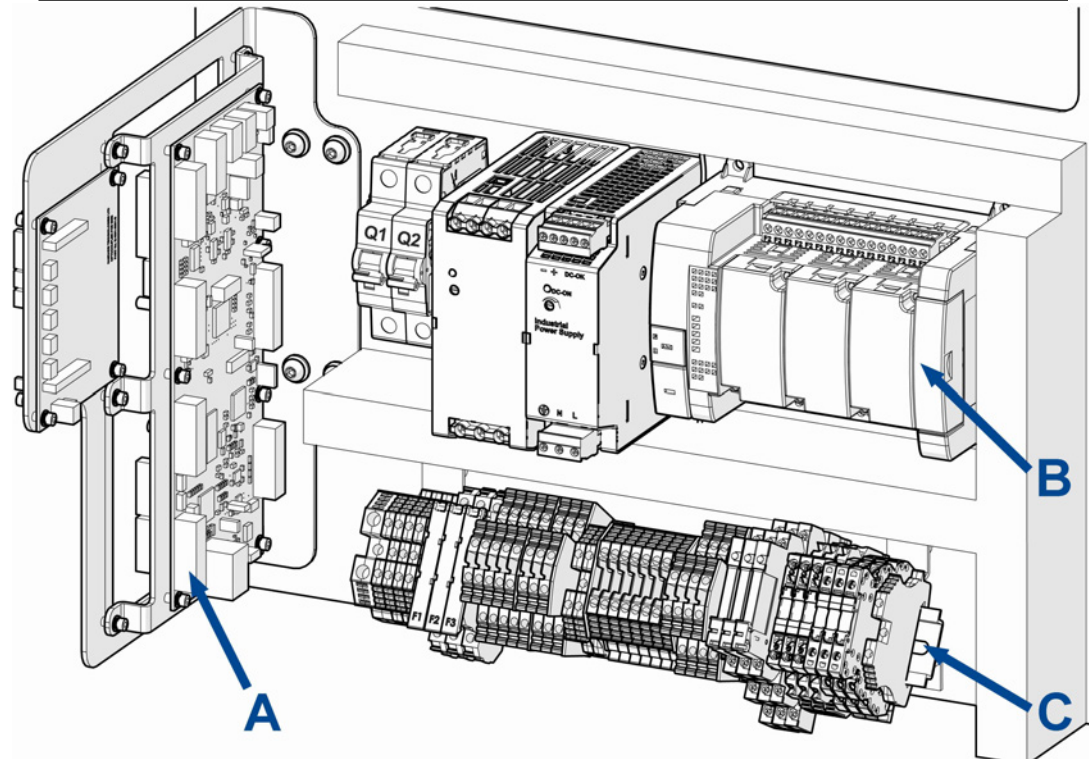

- A. Electronics panel.
- B. Electrical back plate upper DIN rail.
- C. Electrical back plate lower DIN rail.

Figure 2-1: Upper DIN rail components

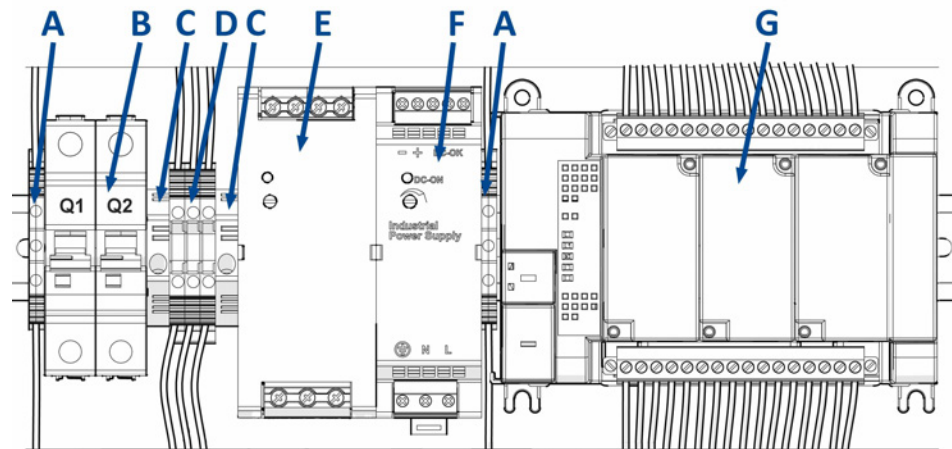

- A. Earth terminal block.
- B. 6A MCB breaker.
- C. End stop.
- D. Terminals.
- E. 24V power supply.
- F. 12V power supply.
- G. PLC.

Figure 2-2: Lower DIN rail components

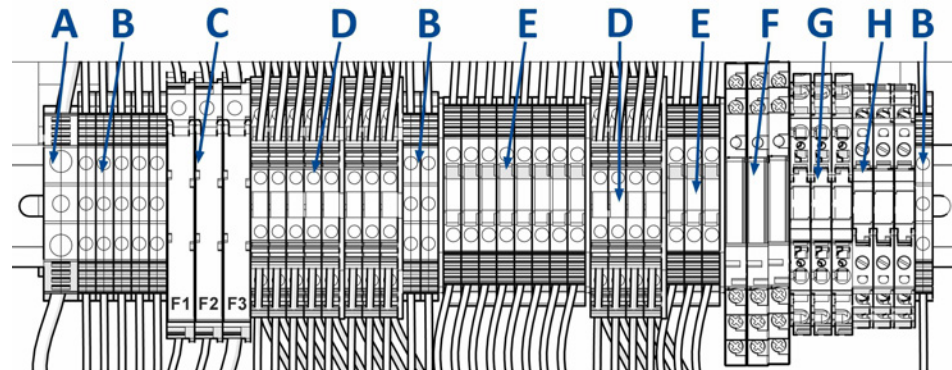

- A. Earth terminal block.
- B. Earth terminal block.
- C. Fuse terminals.
- D. Double terminals.
- E. Terminals.
- F. Relays.
- G. 24V opto-relay.
- H. 12V opto-relay.

2.5 Air preparation plate

Dry filtered compressed air from the factory will be connected to the leak detector. The air supply will pass through the air preparation plate mounted in the 2nd compartment of the lower enclosure. It will be filtered, dried and pressure-regulated before being used to purge the analysis cell when needed or the reject system if attached.

The assembly shown is

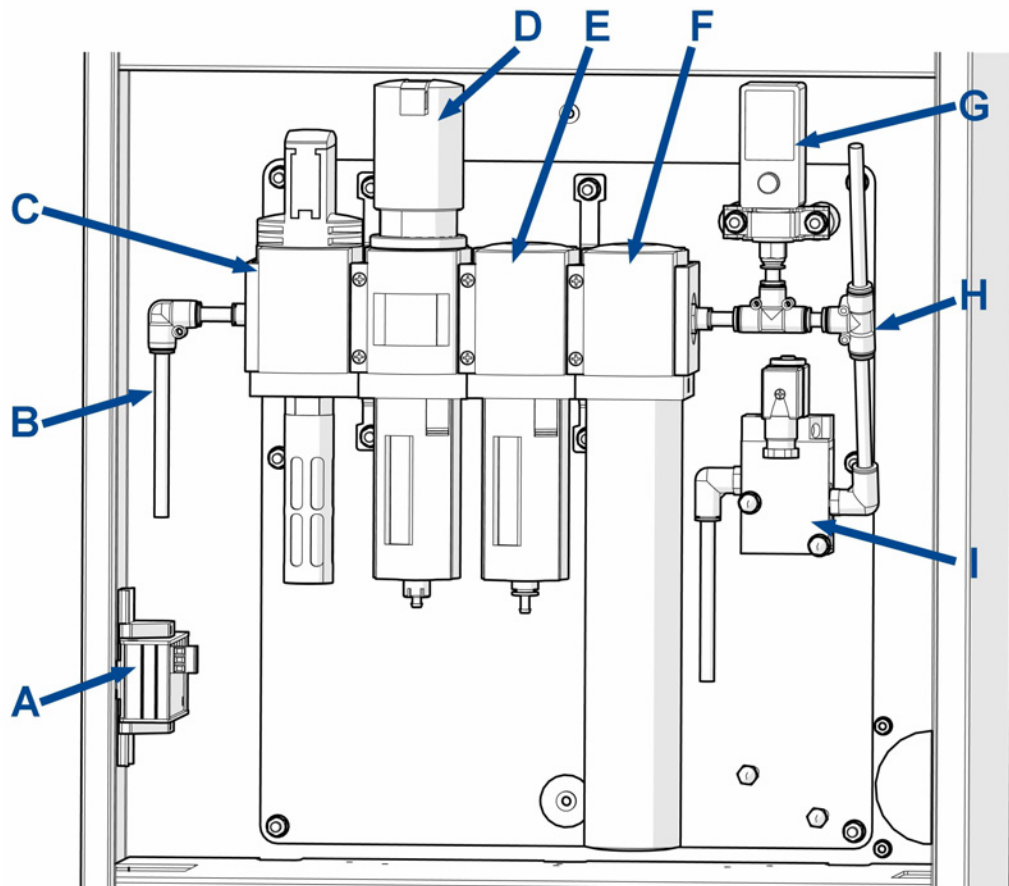

- A. Ethernet hub.
- B. Factory compressed air in.
- C. Shut off valve.
- D. Pressure regulator with 40 µm filter.
- E. 0.1 µm filter.
- F. Membrane dryer.
- G. Pressure switch (MPa).
- H. Filtered air out.
- I. Reject solenoid.

2.6 Blower and electrical shut off

The assembly shown is mounted in the 3rd compartment of the lower enclosure.

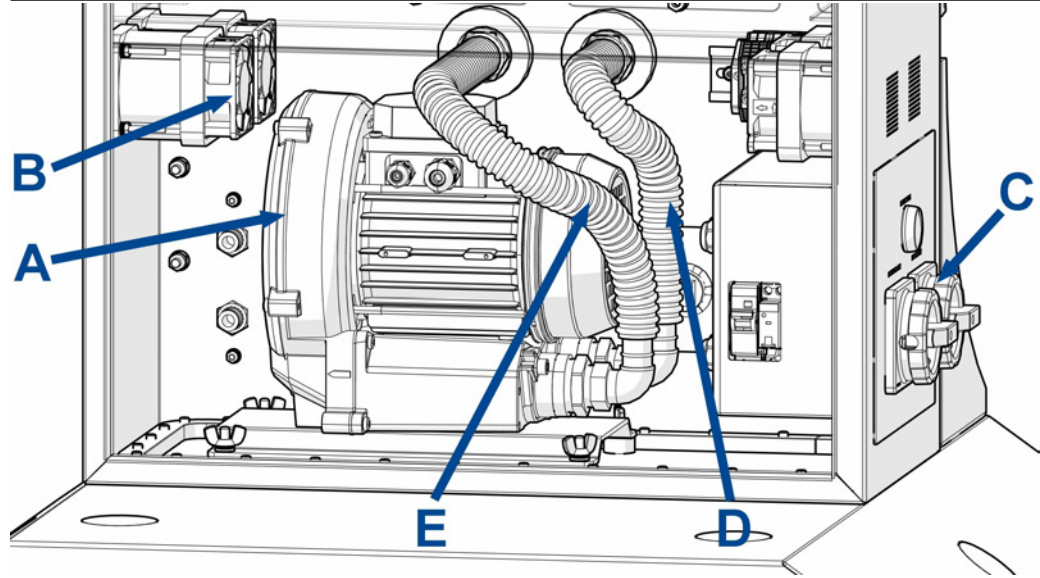

- A. Sample gas blower motor.
- B. Cooling fans.
- C. Electrical shut off and isolation.
- D. Sample gas out vented to the factory.
- E. Sample gas in drawn from the analysis cell outlet.

2.7 Leak detector interface connections

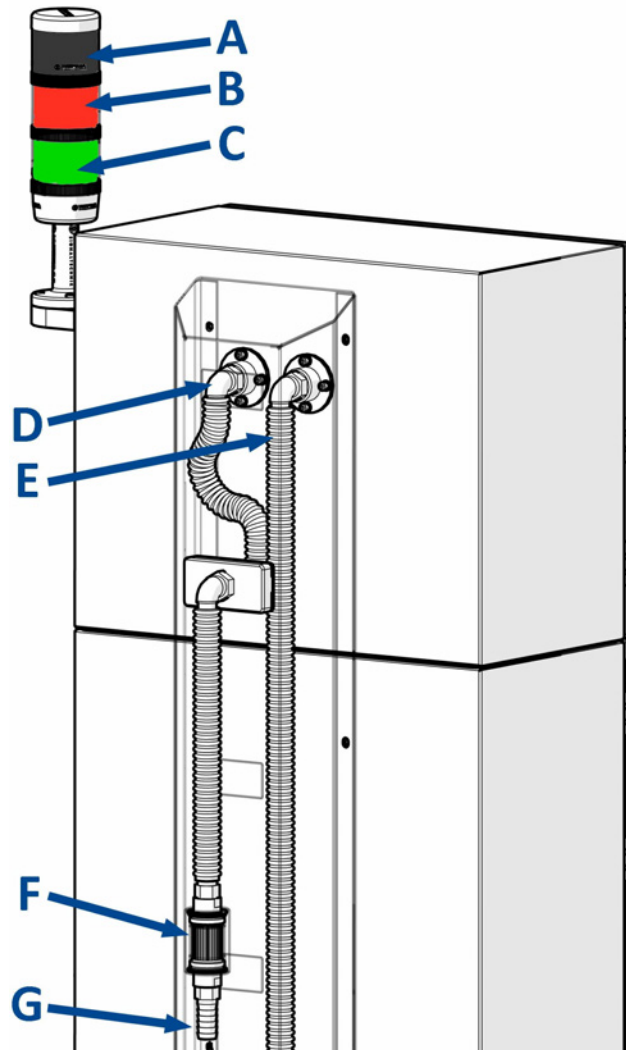

Sample gas inlet connections and alarms.

- A. Beacon buzzer (Optional) - sounds when a reject is detected.
- B. Red beacon - indicates the leak detector systems has a fault.
- C. Green beacon - indicates the leak detector system is working normally.
- D. Sample gas inlet connection to the cell.
- E. Sample gas outlet from the cell to the blower motor inlet.
- F. In line cartridge filter .
- G. Ø19mm inside diameter sample line connected to the sample head. **Maximum** tube length 5 metres.

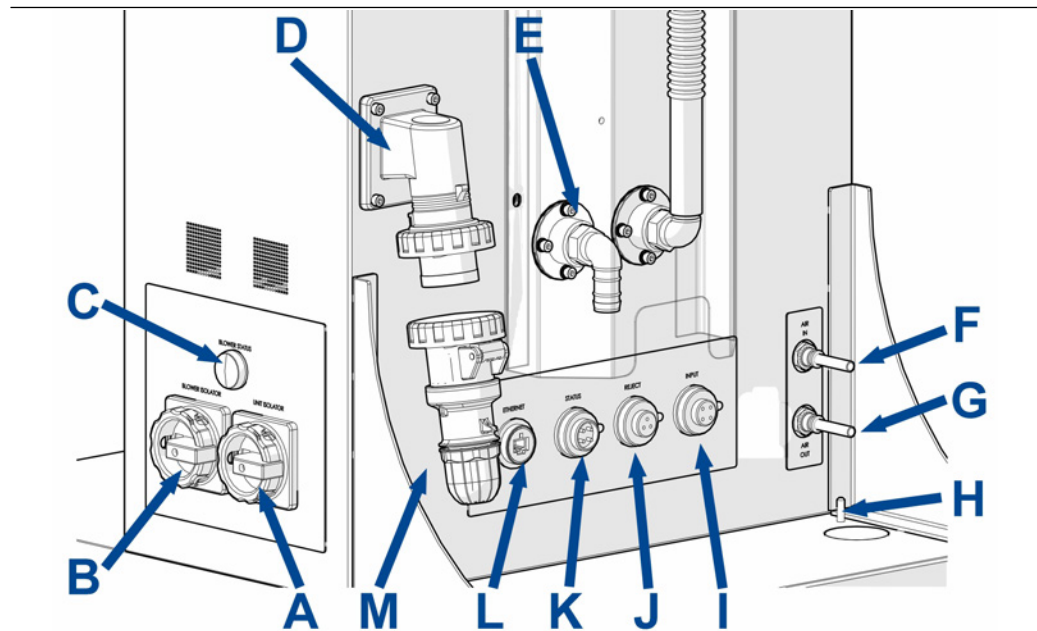

Power, communication and compressed air connections.

- A. Mains On/Off isolator.
- B. Blower motor isolator.
- C. Blower status lamp indicating there is power to the blower motor.
- D. Mains electrical connection point. (Customer option, factory configured for 110VAC or 230VAC).
- E. Sample gas exhaust.
- F. Factory compressed air in connected to the inlet on the air preparation plate.
- G. Optional Compressed air out supplying an air reject system.
- H. M6 Chassis earth connection.
- I. Signal connection from the sample head input gate. Mating connector will be supplied with the unit.
- J. Signal connection from the sample head reject gate. Mating connector will be supplied with the unit.
- K. Status connection for customer telemetry output. connection. Mating connector will be supplied with the unit.
- L. Ethernet connection.
- M. Loose mating plug for the mains electrical connection point. Customer will connect to a suitably rated cable.

2.8 Leak detector installed examples.

The leak detector can be paired with a wide variety of sample heads allowing it to be integrated easily into both new and existing product lines in a diverse range of food and beverage applications.

Examples of which are shown below. Further sampling or bespoke options can be discussed with your local Emerson distribution partners.

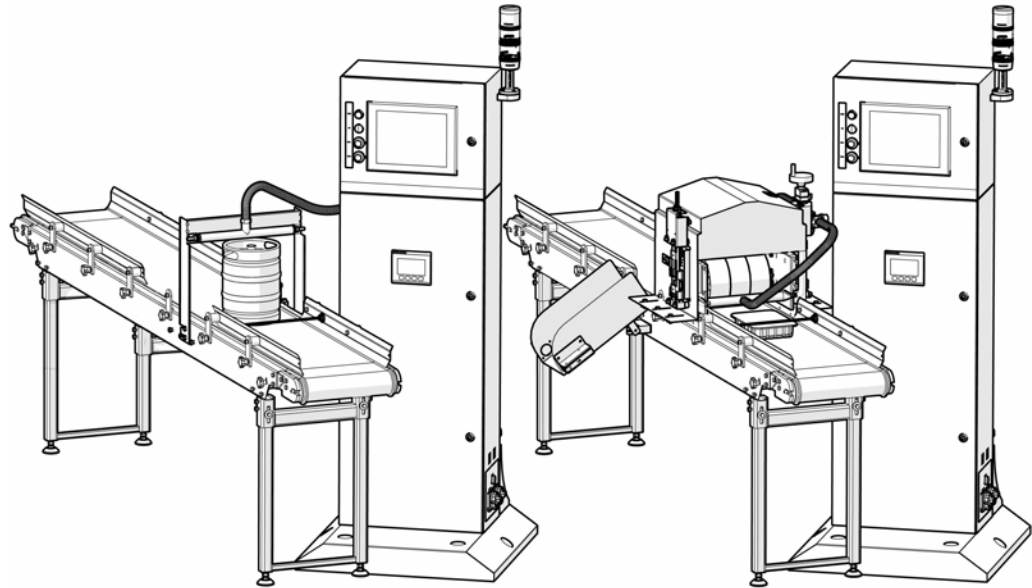

Typical Beverage Production System

Typical Food Production System

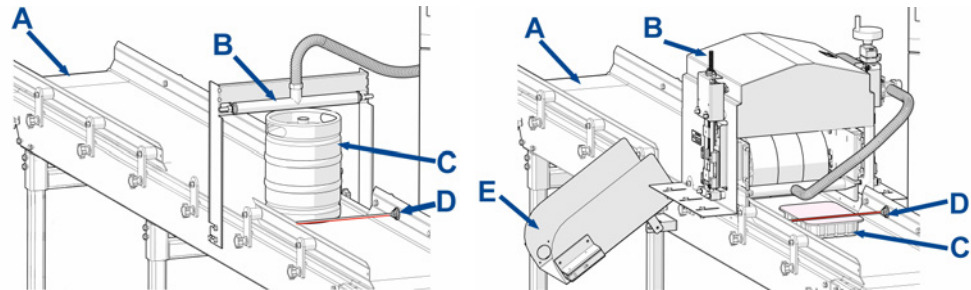

- A. Conveyor (new or fitted to an existing product line).
- B. Sample head examples for illustration purposes.
- C. Product being sampled.
- D. Light gates for product count in and out.
- E. Reject system to eject faulty product from the line.

2.9 Sample head types

Sample heads are used in conjunction with the leak detector to identify packaged products that have a break in the seal integrity as they are carried along a conveyor belt at speed. Sample heads draw air from around the product through a measurement cell in the leak detector. Continual analysis of the sample air will then detect and identify packages with defective seals.

2.9.1 Passive roller

The passive compression roller is a non-powered variable height sample head used to apply a gentle squeeze to packages to encourage Modified Atmosphere Packages (MAP) gas to leak through defect points. The sample head height can be height adjusted on the production line to support multiple product pack sizes.

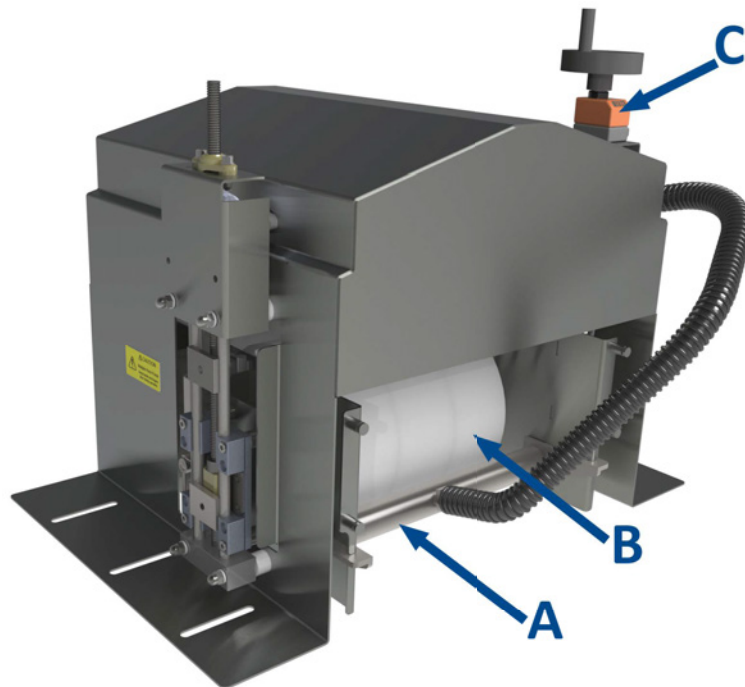

- A. Sample bar.
- B. Roller.
- C. Height adjustment.

The passive roller head consists of three semi flexible rollers with sample bars fitted at the entry and exit of the sample head.

As product packs pass through the passive roller head they are compressed by the roller material flexing. The roller is free to rotate as the packages travel along the conveyor.

The roller height can be adjusted to set the compression being applied to the packages being run at that time.

When packs are compressed the volume inside the pack is temporarily reduced creating areas of increased pressure inside the package. When these areas of increased pressure encounter a defect in the pack seal the MAP gas used can escape the package.

The sample bar at the entry/exit of the passive roller head is connected to an air motor in the CT4215 which continually draws in air from the passive roller head. Any MAP gas leaking from the package will be drawn into the sample bars and through the leak detector triggering the counter and product reject systems.

2.9.2 Keg/barrel

The keg/barrel sample head consists of a simple support frame and sample bar that can be mounted easily onto an existing conveyor line.

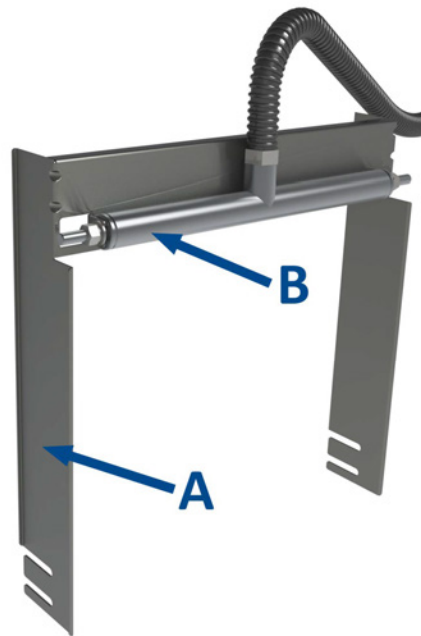

- A. Support frame.
- B. Sample bar.

The sample bar **MUST** be installed < 25 mm (1 inch) above the height of the keg/barrel being tested allowing the product to pass freely underneath the bar.

If CO₂ is leaking from around the valve on the keg/barrel it will be drawn into the sample bar and detected by the analyzer.

3 Installation

3.1 Site selection

Site selection for the leak detector **MUST** consider the following to ensure optimal performance.

Environment The leak detector is for indoor use only.

The leak detector **MUST** be installed in a dry location, protected from the elements, humidity, temperature variations and direct sunlight.

The leak detector is not sealed. It **MUST** be protected if surrounding equipment is being washed/hosed down.

The leak detector **must** be installed in a chlorine free environment.

Location The leak detector **MUST** only be used in non hazardous environments.

The leak detector must be installed in a vibration free location.

Additional space around the leak detector will be required to allow for installation and connection of the sample gas tubing, compressed air supply and electrical power and signal connections.

Additional space will be required to allow the doors to be opened to complete the installation and for any future maintenance.

The leak detector **MUST** be positioned within 2 m (6.6 feet) of the sample head being used to ensure the sample tube connection is kept to a minimum. The total sample tube length must be less than 5 m (16.4 feet).

Note

Longer lengths will result in additional sample delay and additional time between the sampling and rejection points being required.

Weight Lifting equipment will be required when installing the leak detector to remove the transportation wheels.

The leak detector has adjustable feet fitted for leveling the unit when installed.

Fixing points have been provided for the leak detector to be bolted to a suitable floor.

Materials All power and cabling must be selected that meets the minimum requirements defined in this document and comply with local standards.

All tubing used must be selected to suit the leak detector compression fittings installed, pressure rating and compatible with the sample gas being analyzed.

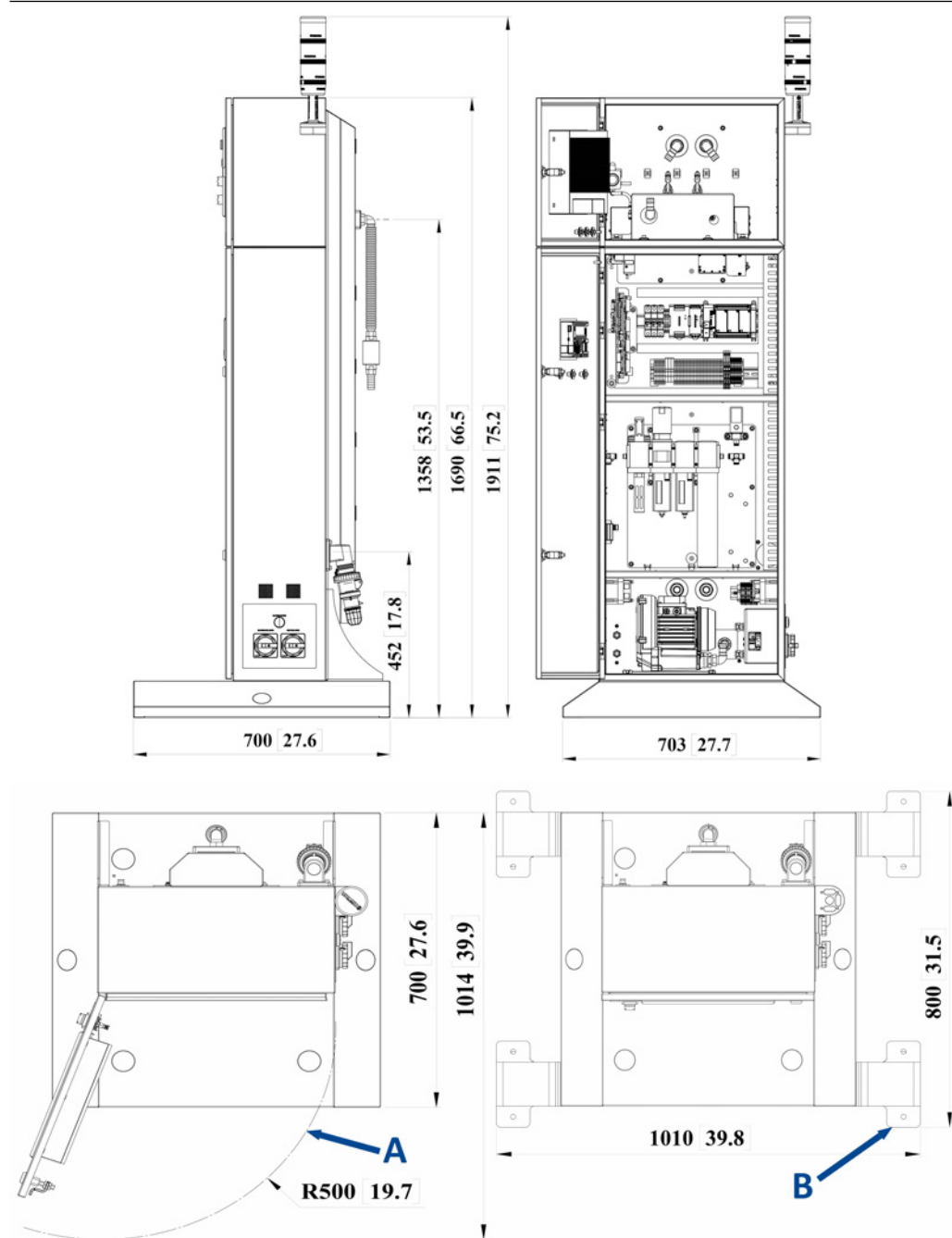

All dimensions are in mm [inches].

- A. Plan view showing floor area required for installation of the leak detector.
- B. Plan view showing floor area required for the leak detector with transportation wheels fitted.

3.2 Unpacking

⚠ WARNING

HEAVY ITEM

Serious injury or death could occur.

The leak detection system weighs 119 kg (263 lb) and should only be moved by a minimum of two people using suitably rated lifting/moving equipment .

To prevent crushing of hands, feet, or other body parts always wear suitable protective gloves and footwear when handling.

The selected installation site must be suitable to support the weight of the leak detection system, cabling and gas sample lines when installed.

On receipt of goods, inspect the Tip N Tell and ShockDot labels fitted to the outside of the shipping container.

Tip N Tell White arrow becomes blue when tilted 80° from vertical.

Shock Dot indicator turns red when a potentially damaging impact has occurred.



The labels will alert the customer to any mishandling of the analyzer when in transit.

Where possible, transport the leak detector in the shipping crate to the site selected for install. Carefully open the container by removing the screws marked with a **RED** dot and lifting the front panel clear as shown.

Note

The panel is heavy and must be supported by a minimum of two people wearing PPE. (leather gloves and safety shoes as a minimum)

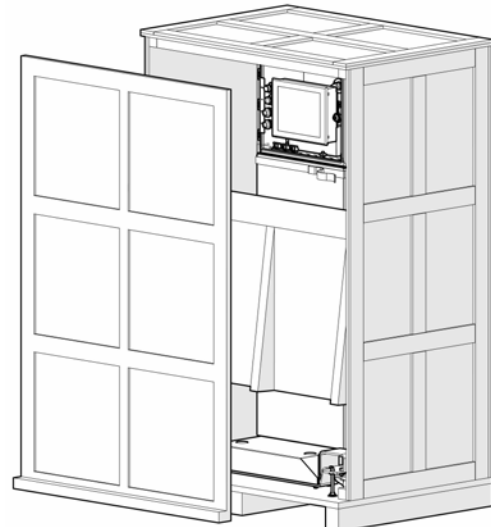

The access ramp can be lifted clear of the slotted holder as shown.

Note

The ramp is heavy and must be supported by a minimum of two people wearing the PPE. (leather gloves and safety shoes as a minimum)

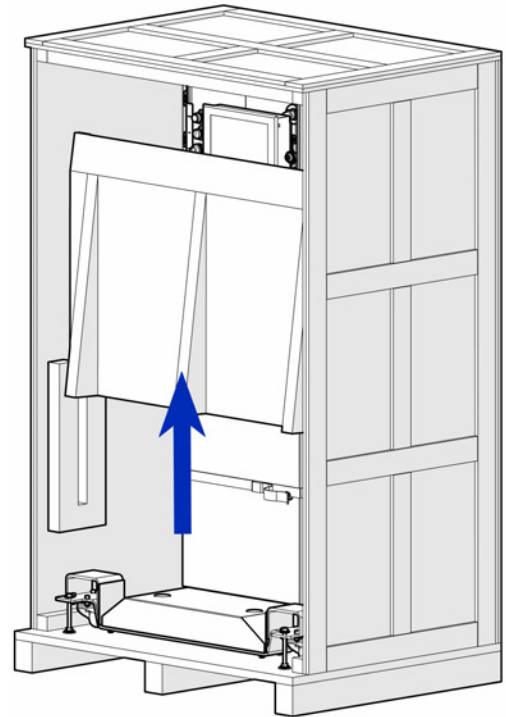

The ramp can now be located at the front of the shipping container. Visually inspect the exterior of the analyzer for signs of damage and verify that all items shipped were received. Report anything found to the maintenance organization.

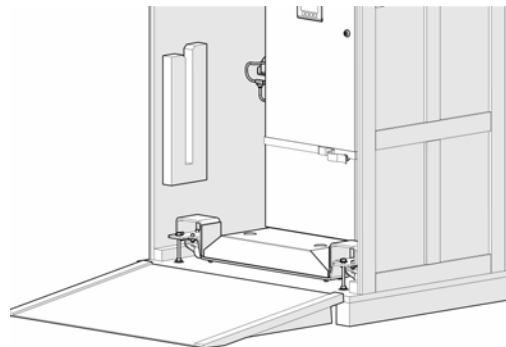

Remove the 4 x M10 nuts and washers securing the leak detector to the floor of the shipping container.

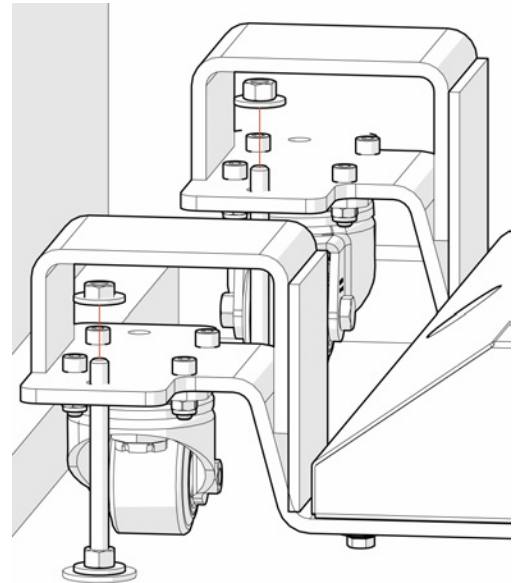

Remove the threaded rod from the container floor.
Finally, remove any straps used to secure the leak detector upper sections from vibration during transit.

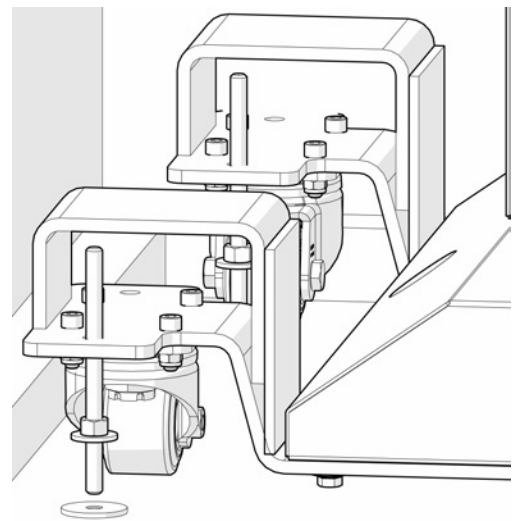

Removing the Leak Detector from the shipping container Option 1.

The leak detector can now be wheeled out of the shipping container.

Control the leak detector as it transitions down the ramp.

Note

Care must be taken as the ramp is not secured to the shipping container preventing it moving as the leak detector is removed.

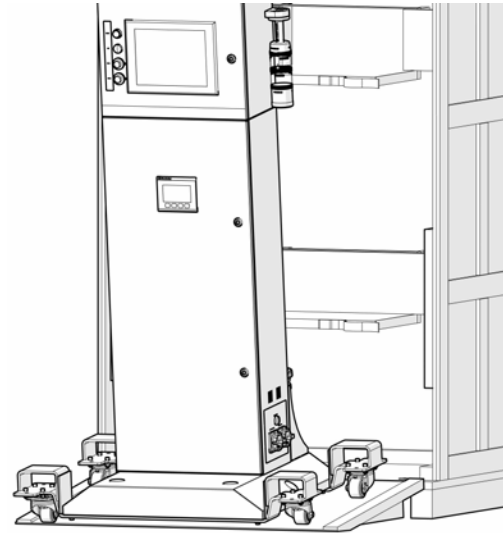

Removing the Leak Detector from the shipping container Option 2

Remove the ramp from the front of the container to allow fork lift access.

4 x Fork lift pockets are provided as part of the transportation trolleys.

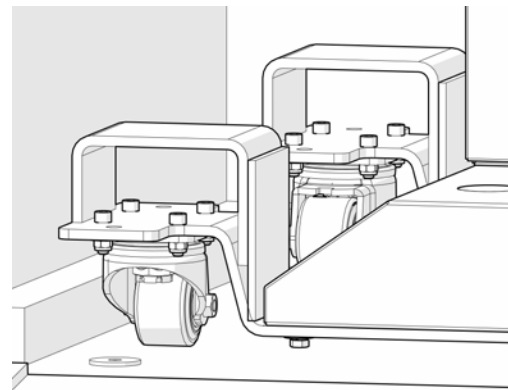

Care must be taken if a fork lift is used as there is limited head clearance between the shipping container and the top of the leak detector.

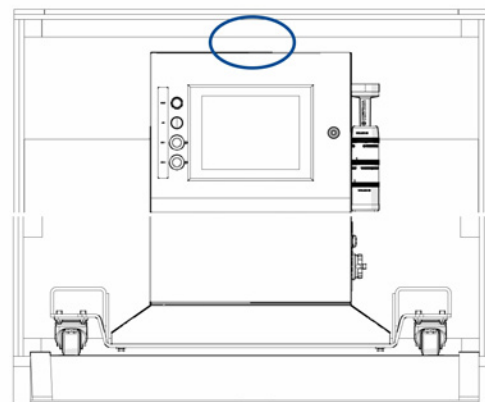

3.3 Installing the leak detector

The location selected for the leak detector will be in accordance with the [Site selection](#) criteria. Free access to the connections on the rear of the leak detector will be required at all times.

⚠ WARNING

HEAVY ITEM

Serious injury or death could occur.

The leak detection system weighs 119 kg (263 lb) and should only be moved by a minimum of two people using suitably rated lifting/moving equipment .

To prevent crushing of hands, feet, or other body parts always wear suitable protective gloves and footwear when handling.

The selected installation site must be suitable to support the weight of the leak detection system, cabling and gas sample lines when installed.

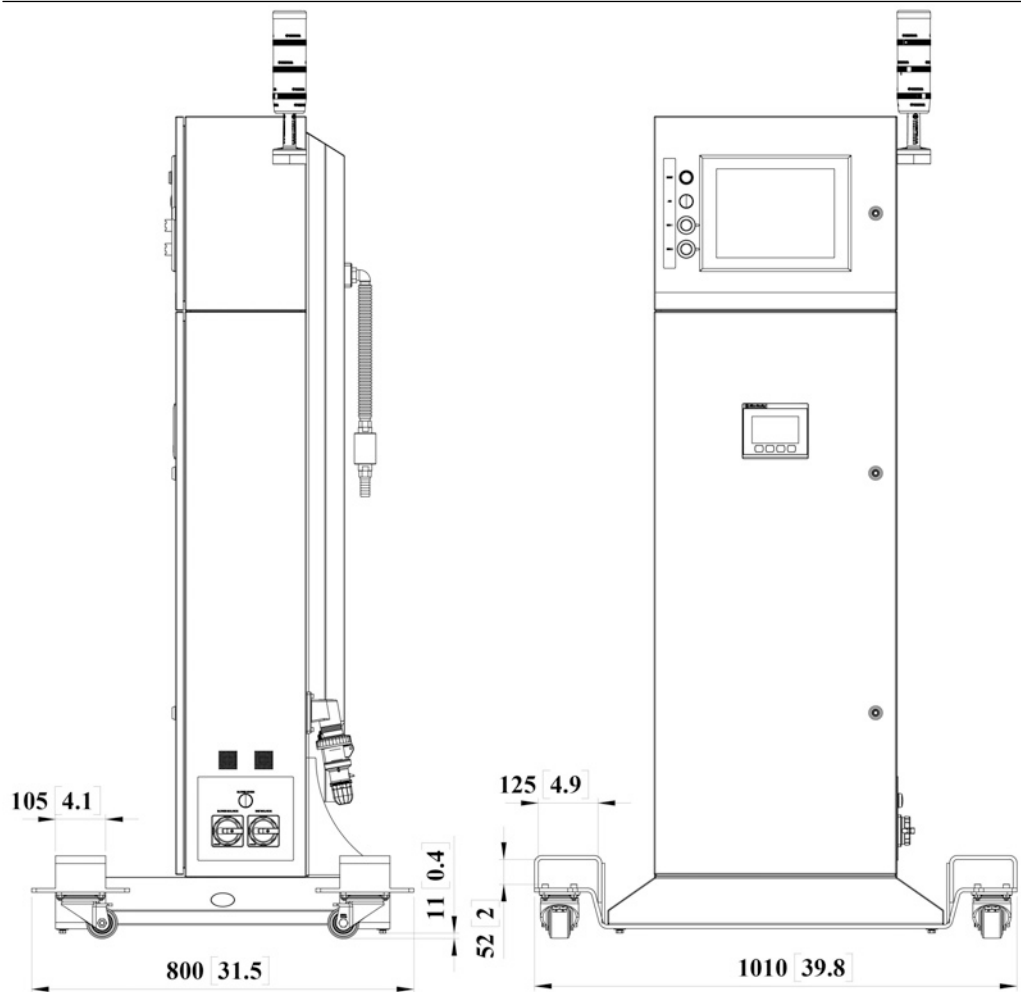

All dimensions are in mm [inches].

The location selected will need two holes drilled in the floor 636mm [25in] apart to suit M8 anchor bolts.

This will secure the leak detector when installed.

- A Securing anchor bolt hole dimensions.
- B Leveling feet pads.
- C M8 Anchor bolt.
- D Additional oversized washer.

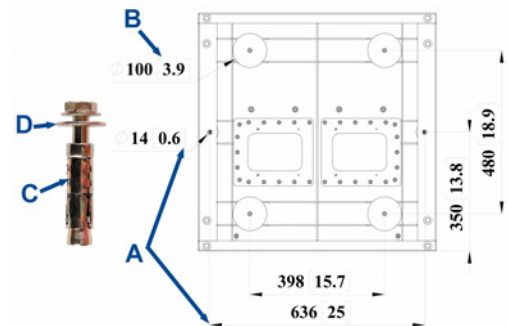

Once the leak detector has been moved into position the transportation wheels must be removed.

Note

There is limited clearance between the M8 bolt head and the floor as shown opposite.



Remove the 8 off M8 bolts and washers securing the transportation wheels to the leak detector base.

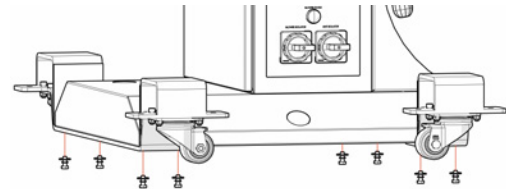

It will be necessary to support the leak detector enclosure while the transportation wheels are slid out from under the unit.

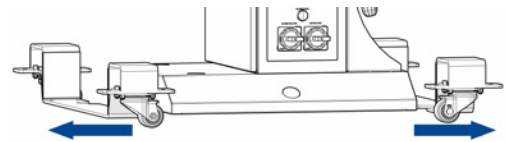

Remove the two press fit covers to access the bolting position.
Fit the securing bolts loosely to locate the leak detector in place. **DO NOT TIGHTEN** at this time.

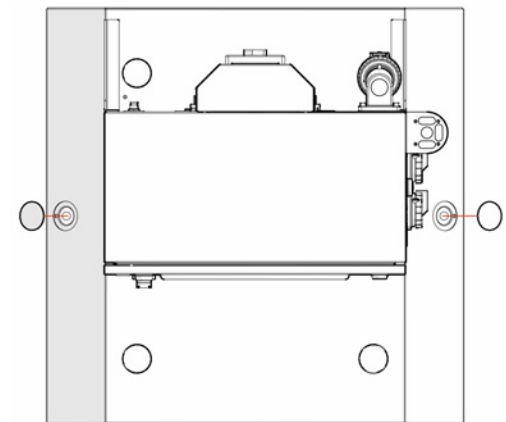

Remove the 4 off press fit covers to access the adjustable feet.

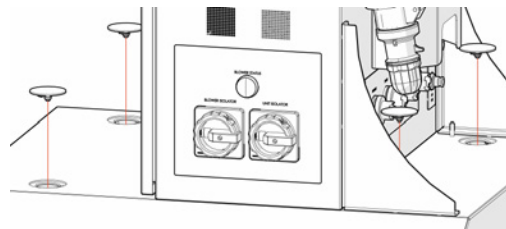

Using a 14mm AF socket adjust the feet to suit giving a horizontal stable platform for the leak detector.
Replace the covers.

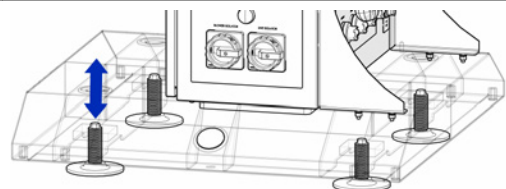

Tighten the securing bolts and replace the 2 off press fit covers.

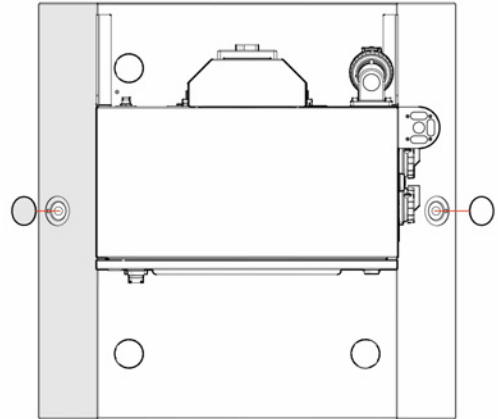

The beacon has been fitted to the enclosure upside down for transportation.

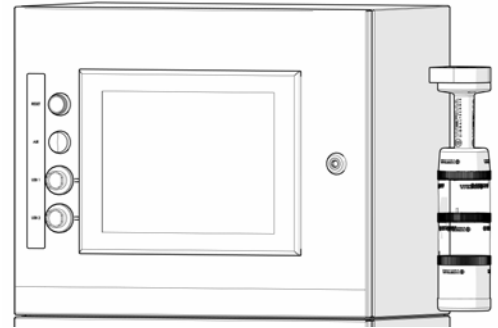

Using an 8mm AF hex allen key give a quarter turn to open the top enclosure door lock.

Note
Cables are connected to the inside of the door.

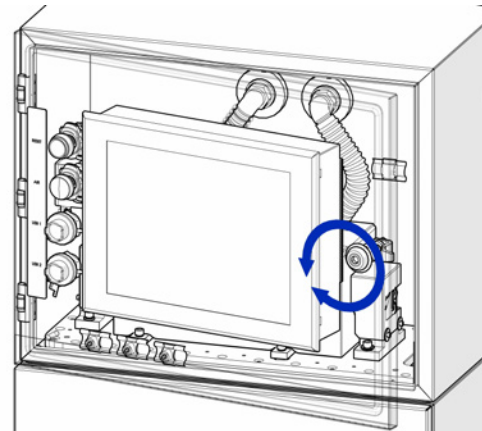

Remove the M4 fasteners used to secure the beacon to the enclosure, rotate the beacon and refit the fasteners. Close and lock the enclosure door when complete.

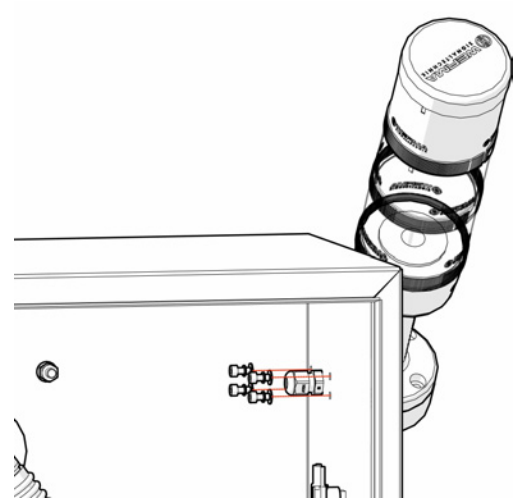

The hose from sample head can now be connected to the inlet filter fitted to the rear of the leak detector. Installation of the leak detector is now complete. Please refer to separate instructions for installation of the sampling head required.

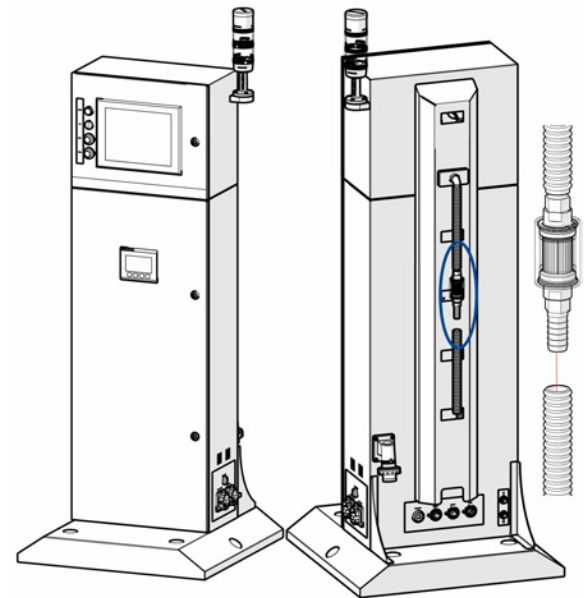

3.4 Electrical, signal, compressed air in and sample gas connection details

3.4.1 Mains electrical connection

⚠ DANGER

ELECTRIC SHOCK

Serious injury or death will occur.

The leak detection system operates using mains voltage and must be switched off and the power cable removed before opening the analyzer.

⚠ WARNING

HAZARD BY WRONG SUPPLY VOLTAGE

Serious injury or death could occur.

The rated voltage for the leak detector is fixed during the manufacture and defined on the ratings label fitted to the unit.

The voltage at the installation site must meet the rated voltage required.

Procedure

1. All electrical /connections are fitted to the rear panel of the leak detector .
2. Power to the leak detector is connected through the Mains Power Inlet using the connector provided.

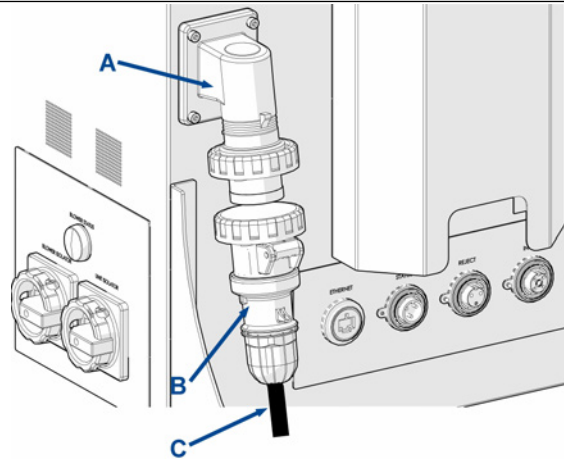

- A. Mains power connection.
- B. Power cable connector (supplied loose)
- C. Customer supplied power cable. (minimum required cable [Specification](#) will be defined by a competent Engineer or technician ensuring cable selection meets local standards for power demands for the cable length required.

Item	Designation	Type	Rating	Description		
A	AC supply	IEC 60309 industrial right angle connector 2P+E	Yellow: 110 - 130 V Blue: 200 - 250 V	Fitted to the rear of the leak detector.		
B	AC supply	IEC 60309 industrial cable mount connector 2P+E	Yellow: 110 - 130 V Blue: 200 - 250 V	Supplied loose for customer connection.		
				<table style="width: 100%; border: none;"> <tr> <td style="padding-left: 20px;">Pin 1</td> <td style="padding-left: 20px;">Live</td> </tr> <tr> <td style="padding-left: 20px;">Pin 2</td> <td style="padding-left: 20px;">Neutral</td> </tr> <tr> <td style="padding-left: 20px;">Pin 3</td> <td style="padding-left: 20px;">Earth</td> </tr> </table>	Pin 1	Live
Pin 1	Live					
Pin 2	Neutral					
Pin 3	Earth					
C	Power cable	Mains 3 core 1.5mm ² power cable, sheathed.	16A, 300 - 500V (minimum)	Customer supplied power cable in accordance with applicable local and national codes.		

3.4.2 Signal and earthing cable connections

⚠ WARNING

MAINTENANCE

Serious injury or death could occur.

Only authorized maintenance personnel can carry out repair work on the leak detection system.

On completion verify:

- All tools and equipment are removed.
- No contamination (water/dust) is in the compartments.
- Leak detector is wiped clean.
- Vents are clear and free from obstruction.
- Verify that system is in a safe state for operation.

Procedure

1. Use the information provided in this section to make the required electrical connections.
2. The Ethernet connector is used by either the service technicians for downloading data for failure diagnosis purposes or for a customer control center.

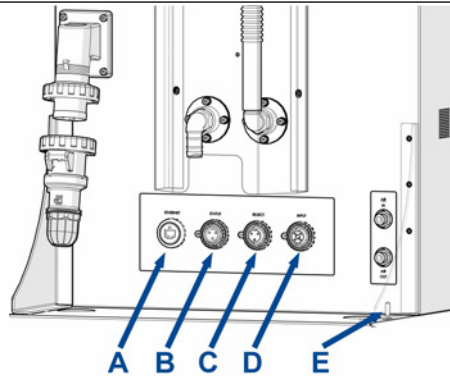

Item	Designation	Type	Max rating	Description
A	Ethernet	RJ45 Ethernet	N/A	Communication with sensor.
B	Status	Bulgin 3P male	30Vdc, 1A	Relay contacts to signal the system is running correctly. Status connection for customer telemetry output connection. Mating connector will be supplied with the unit.

Item	Designation	Type	Max rating	Description
C	Reject	Bulgin 3P female	24Vdc, 0.8A	Signal to trigger the rejection solenoid when a defective pack is detected. Signal connection from the sample head reject gate. Mating connector will be supplied with the unit.
D	Input gate	Bulgin 4P female	24Vdc	Gate signal from the sensor to count incoming packs. (Input current 10mA maximum) Signal connection from the sample head input gate. Mating connector will be supplied with the unit.
E	Earth connection	N/A	N/A	M6 threaded stud for customer chassis earthing point.

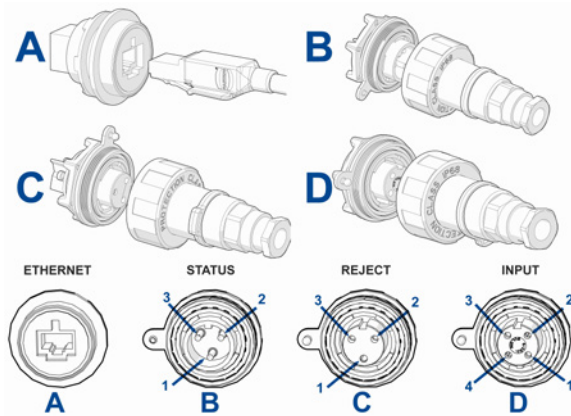

Pin orientation shown when looking at the rear panel connections.

Pin	Status (B)	Reject (C)	Input (D)
1	Relay normally closed	24V	24V
2	Relay common	Switched 0V	0V
3	Relay normally open	No connection	Signal 1
4	N/A	N/A	Signal 2

3.4.3 Compressed air and sample gas connections

⚠ WARNING

HIGH PRESSURE AIR

Serious injury or death could occur.

The compressed air supply operate at pressures that can cause injury.

⚠ CAUTION

AIR SUPPLY

Minor or moderate injury will or could occur

Air provided must be connected from a pressure regulated clean, filtered and moisture free supply source.

Procedure

1. Sample gas connection and flow path shown below.
2. Compressed air connections for purge and reject option.

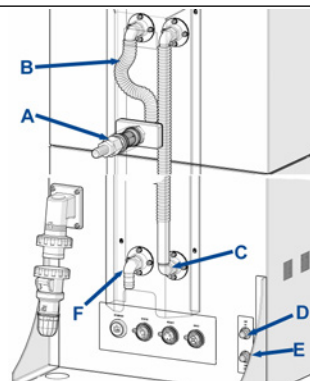

- A. Sample gas connection point.
- B. Sample gas inlet to the analysis cell.
- C. Sample gas outlet from the analysis cell to the blower motor inlet.
- D. Connection from the factory compressed air supply using 8mm outside diameter push fit plastic tubing. Factory compressed air in connected to the inlet on the air preparation plate.
- E. Optional compressed air out supplying an air reject system. 8mm outside diameter push fit plastic tubing.
- F. Sample gas exhaust from the blower motor.

4 Start-up procedure

⚠ WARNING

HIGH PRESSURE AIR

Serious injury or death could occur.

The compressed air supply operate at pressures that can cause injury.

⚠ CAUTION

AIR SUPPLY

Minor or moderate injury will or could occur

Air provided must be connected from a pressure regulated clean, filtered and moisture free supply source.

NOTICE

To stop the start-up procedure at any time, set the main circuit breaker to **OFF**.

Procedure

1. Locate the main factory circuit breakers for the power supply and set to **OFF**.
2. Ensure that the leak detector has been installed correctly as described in [Installing the leak detector](#).
3. Ensure that the leak detector enclosure doors are closed and locked. If you cannot close and lock the doors, report it to the maintenance organization and do not proceed until the door has been repaired.
4. Visually inspect the leak detector's exterior for signs of damage reporting anything found to the maintenance organization.
5. Confirm that all connections to the leak detector and the sample handling system fitted to the production line are secure and there is no twists or kinks in any of the hose connections or visible damage.
6. Confirm the power connector is securely connected to the back of the leak detector.
7. Once these prestart checks have completed the power can be turned on at the main isolator.
8. Switch on the leak detector at the unit isolator mounted on the lower right panel.

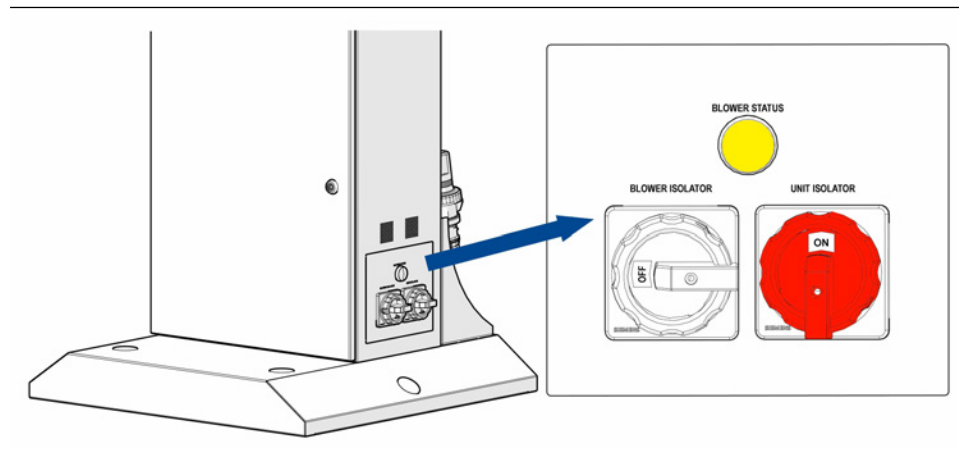

9. The system will take approximately two minutes to boot up at which point the startup screen will come on line.

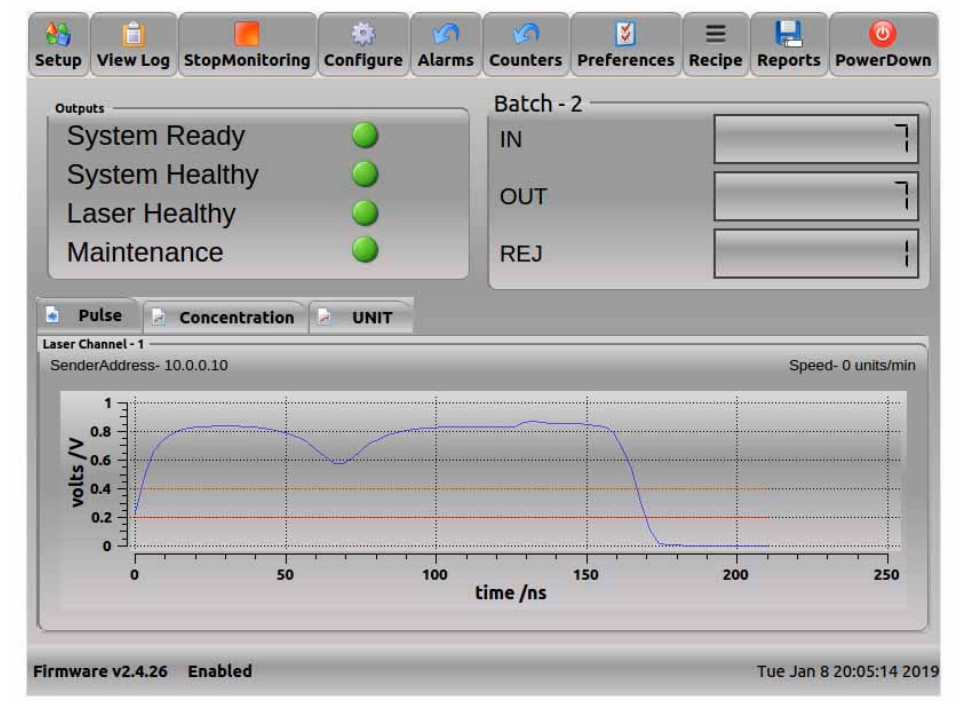

10. Switch on the factory compressed air supply.
11. Switch on the blower motor at the blower isolator switch mounted on the lower right panel, the blower status lamp should be on, if not report the fault to the maintenance organization.

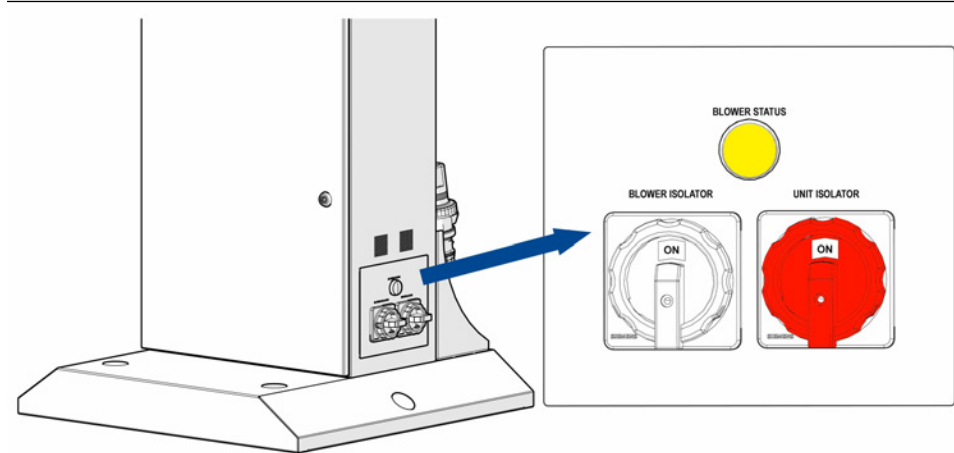

It is recommended that the blower is switched off when the production line is not running. This will extend the lifetime of the sample air filter.

12. Press the Reset button and ensure there is a green light on the beacon to confirm the leak detector is now operational.

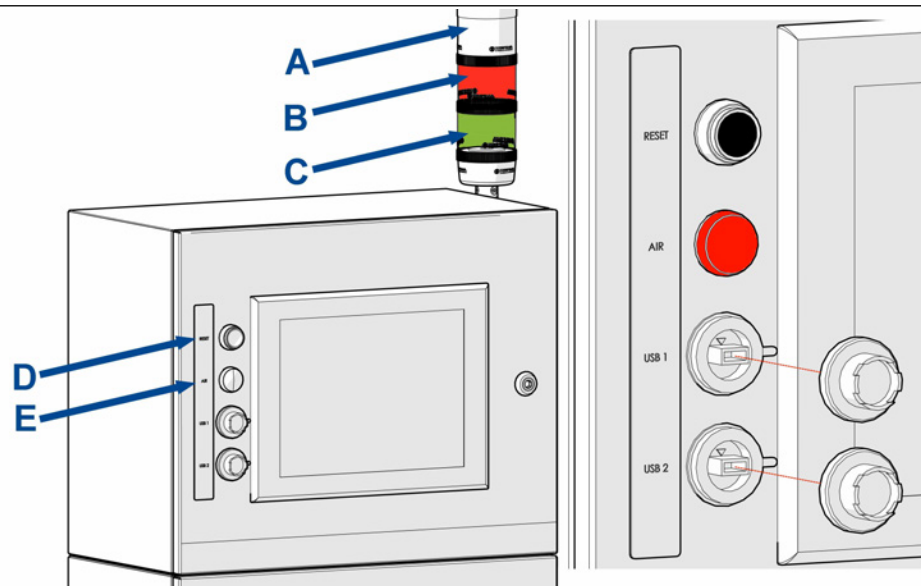

- A. Beacon buzzer. (line unhealthy/line stop)
- B. Beacon red LED (line unhealthy/line stop)
- C. Beacon green LED. (line healthy)
- D. Reset button.
- E. Air fault indicator.

5 Shut down procedure

⚠ WARNING

HIGH PRESSURE AIR

Serious injury or death could occur.

The compressed air supply operate at pressures that can cause injury.

⚠ CAUTION

AIR SUPPLY

Minor or moderate injury will or could occur

Air provided must be connected from a pressure regulated clean, filtered and moisture free supply source.

NOTICE

Failure to follow the correct shutdown procedure may damage the on board systems for the leak detector.

In an emergency, the leak detector can be turned off at the unit isolator.

Procedure

1. Turn off the compressed air supply connected to the leak detector.
2. On the main display screen, select the **PowerDown** option indicated.



3. The software will now start the shutdown process.
4. After a short delay the main display screen will switch off.
5. Switch off the unit and blower isolators mounted on the side panel.

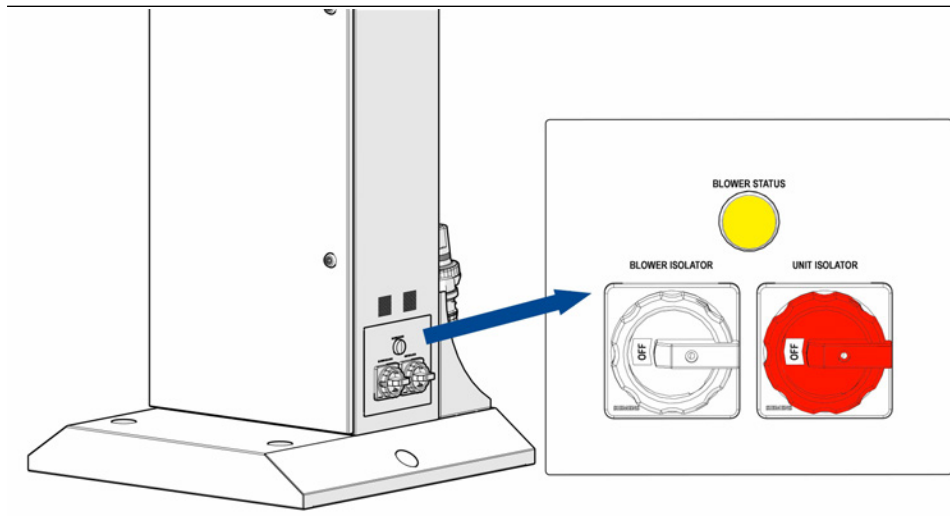

6. Mains voltage is still being applied to the leak detector. Turn off the mains power at the customer supplied circuit breaker or remove the plug.

6 Software interface description

The leak detector is designed to run with minimal user interaction required unless a fault is detected. Under normal operating conditions the green LED will be on to show everything is operating correctly, the red LED shows comes on when a fault has been detected.

6.1 Leak detector manager

The leak detector manager software is designed to provide clear information of the production through put of the line being monitored.



- A. Control options.
- B. **Outputs:** Explained in [Status lamps / errors](#).
- C. Counters showing product throughput.
- D. **Screen option selections:** Toggle between the three tabs to change which visual information is displayed.

The **Pulse display** shows the laser pulse amplitude.

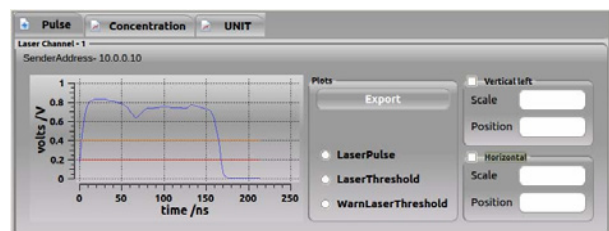

The **Concentration** display shows the sample gas being measured at the sample head for each pack. A leaking pack would show as a spike on the trace as shown.

If the spike reaches the red upper threshold, a signal is sent to the PLC and the rejection solenoid triggering the rejection of the faulty pack from the line.

The yellow lower threshold is typically set at 80% of the upper threshold to capture any packs with marginal leaks. Allowing the operator to investigate where required.

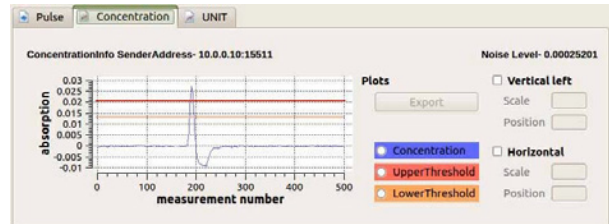

The **Unit display** continually shows the readings being taken for each product pack tested on the production line.

The plot shows all data points between the input and output gate and records the size of any rejection spike detected.

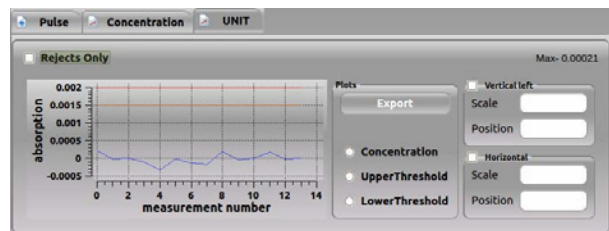

6.1.1 Setup

Factory only configuration screen

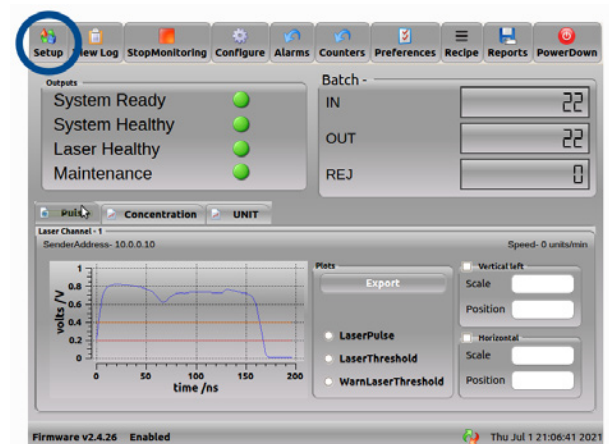

6.1.2 View log

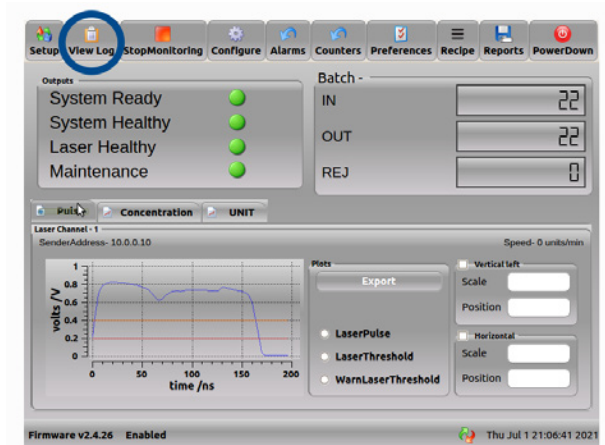

Select **View Log**.

This activates a log screen which shows various automated actions taken by the system software. Used in case of communications issue with the laser system.

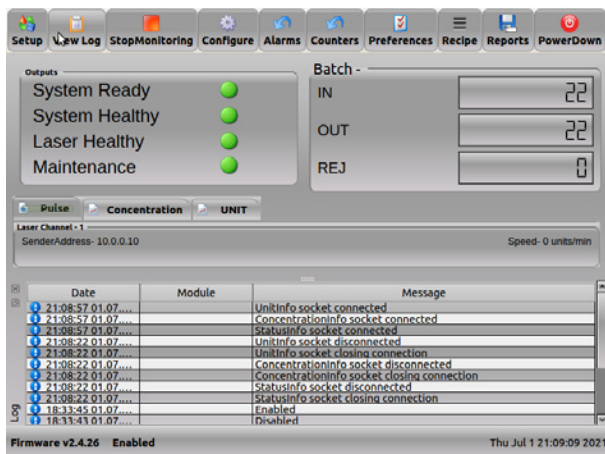

6.1.3 Monitoring start/stop

The leak detector automatically starts monitoring after startup has been completed. Pressing the stop monitoring button will pause the system software.

Note

It will not stop the leak detector, packages will continue to be detected and rejected.

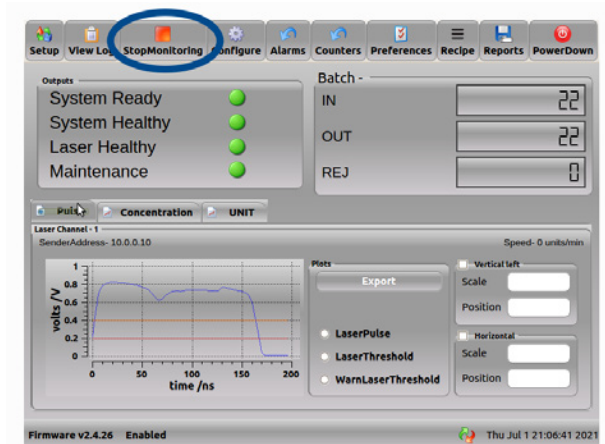

Pressing the start monitoring button will restart the system software. Counters will continue from where they left off

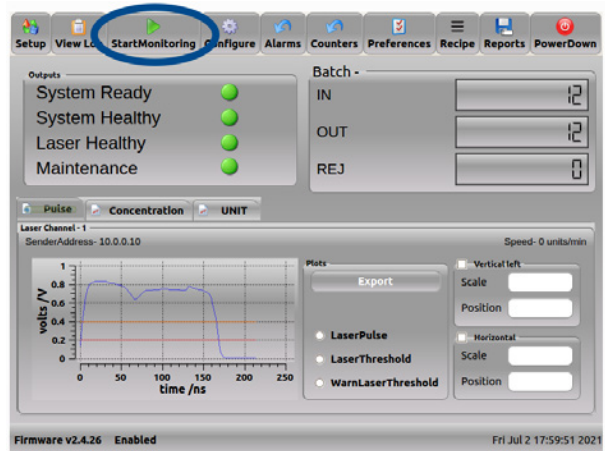

6.1.4 Configure

The configure button allows access for specialists during setup and password protected. is not required to be accessed by the operator.



Operator access is not required, select cancel to return to the main screen.

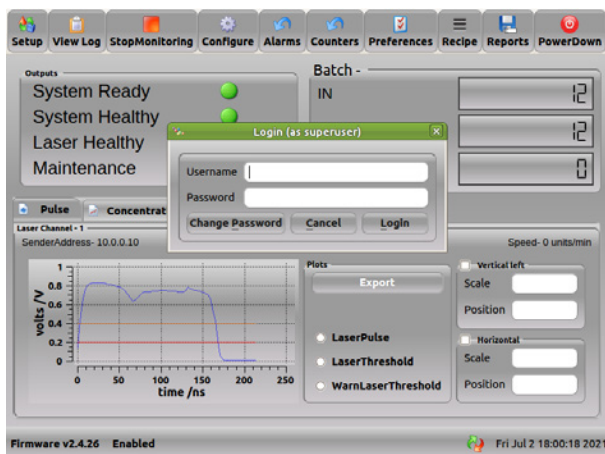

6.1.5 Alarms

The main display screen shows that the system has detected a fault. Having investigated or cleared the fault the operator can press the alarm button to cancel the alarm



Select Yes to reset the alarm.

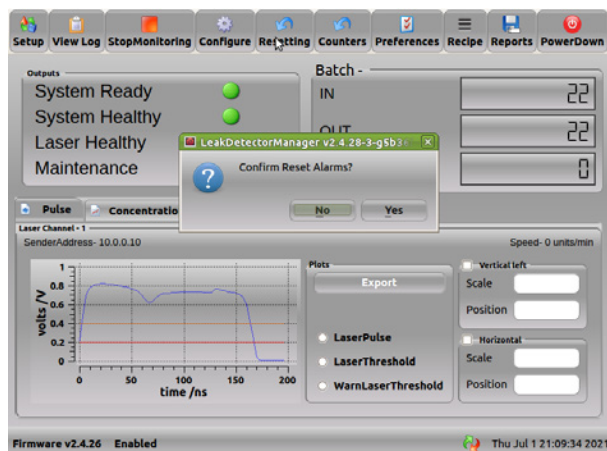

Provided the fault has been cleared the main display screen will return showing a green healthy display. If the system is still detecting a fault refer to [Troubleshooting and diagnostics](#).

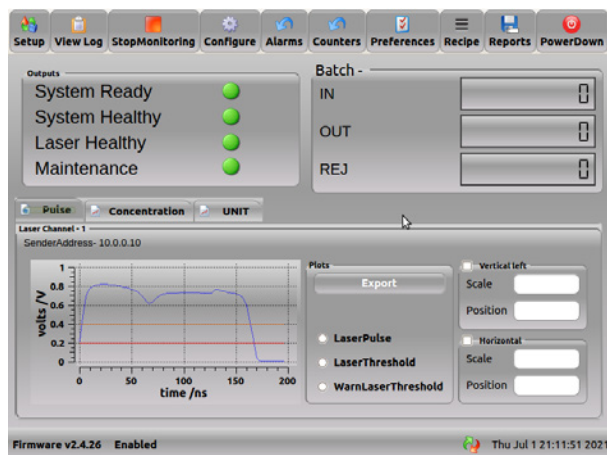

6.1.6 Counters

Select the counters button to zero the product count being monitored on the production line.

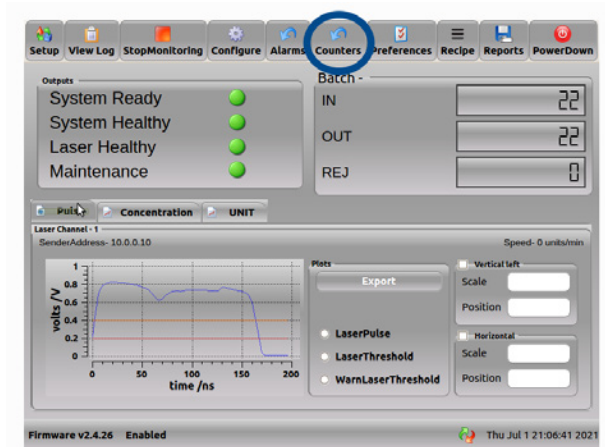

Confirm counters have to be reset.

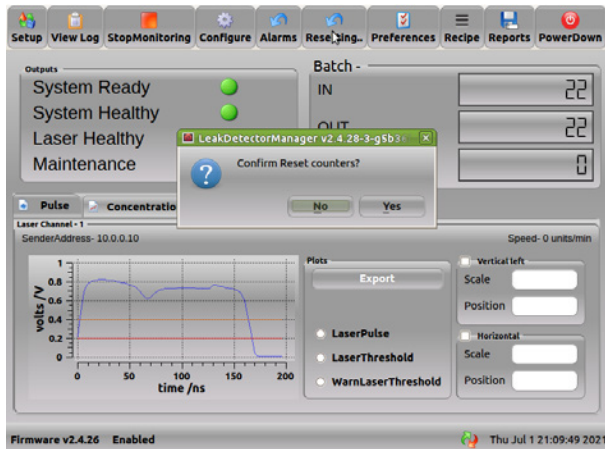

Counters reset.

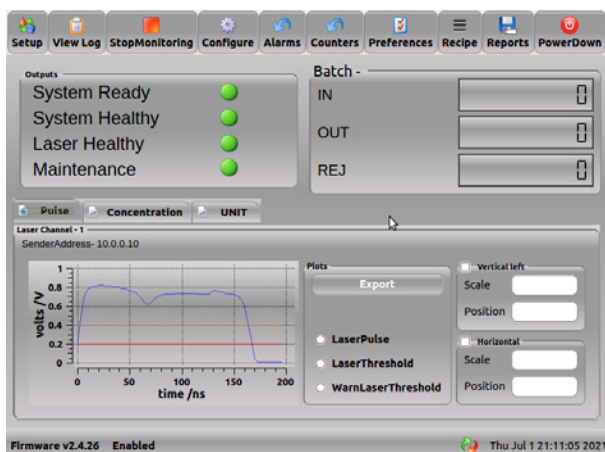

6.1.7 Preferences

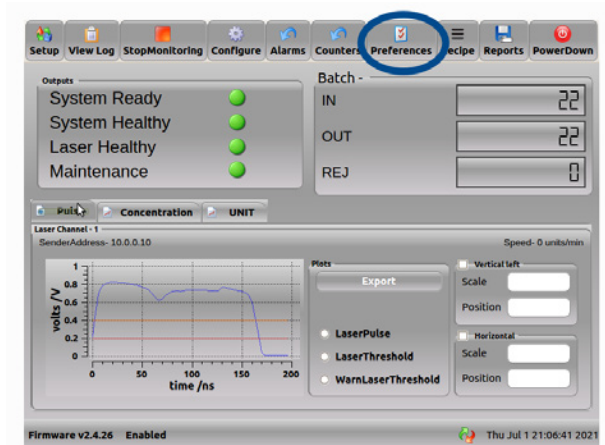

Select **Preferences**.

The Preferences display gives 3 options.

- Full screen** If checked, system software will run in full screen mode.
- Auto start monitoring** If checked, software will start monitoring on startup.
- Display scale** If checked, software will display scaling options for graphs on bottom right of screen.

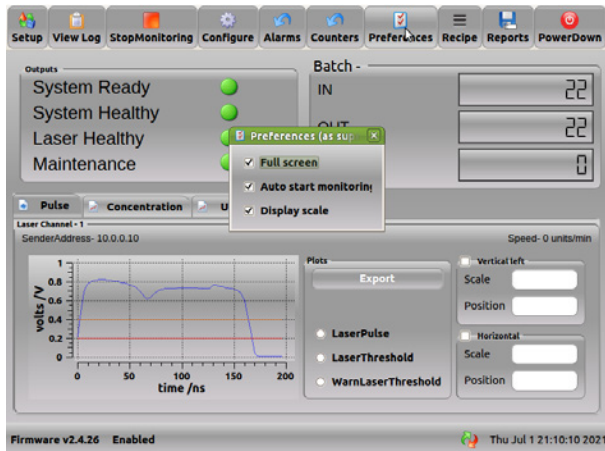

6.1.8 Recipe

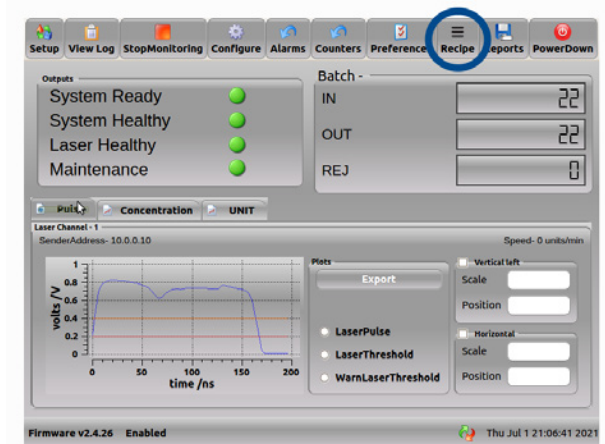

The recipe screen allows the user to change the system leak detection thresholds for different product packs.

Login with your user credentials

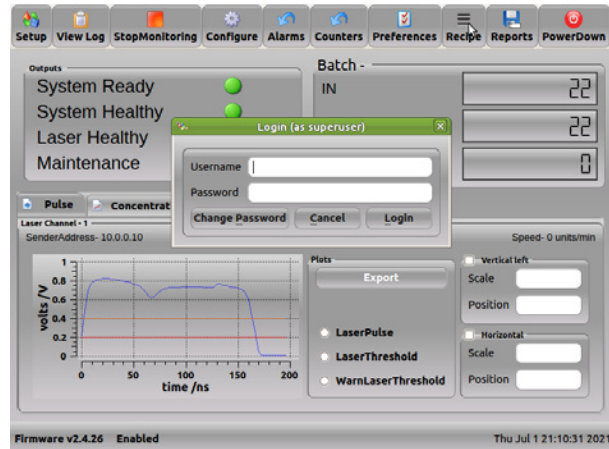

Select the recipe name required from the list.
Press **Download**.

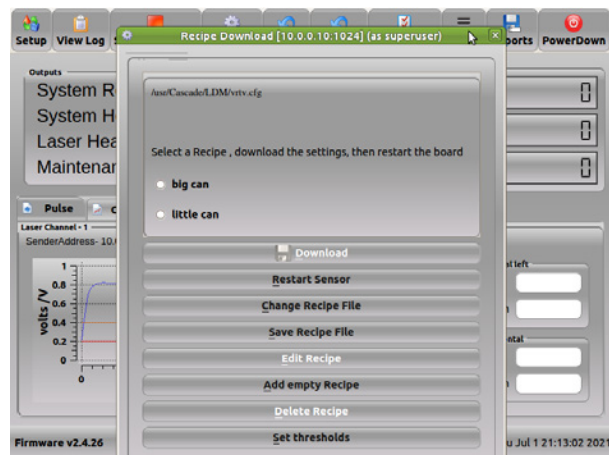

Select **Yes**.
On the following pop ups, select **Yes**.
After a few seconds delay press **Restart Sensor** and the recipe window will disappear.

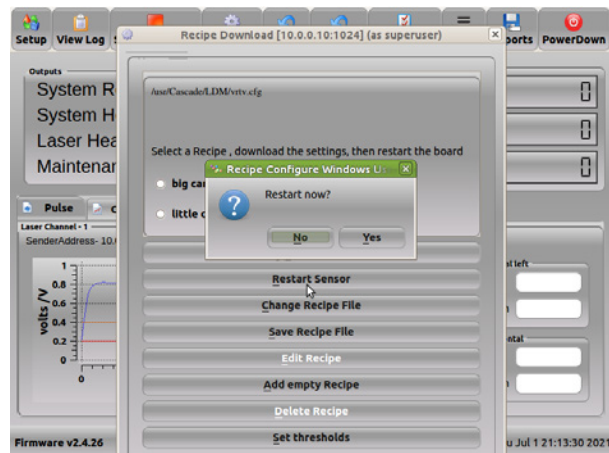

Select **Start Monitoring** to restart the measurements using the new recipe selected.

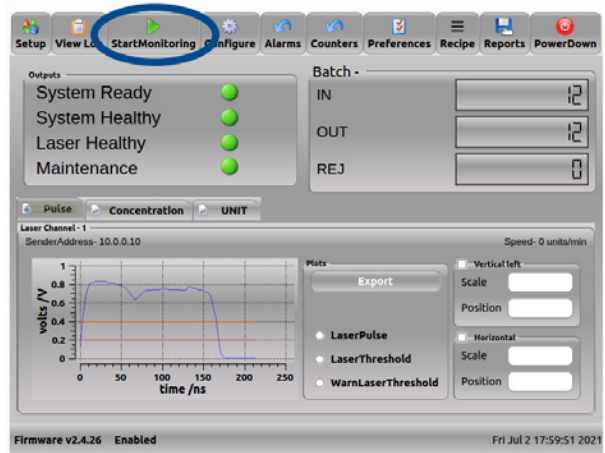

Upper and lower thresholds can be manually adjusted by selecting **Set Thresholds**.

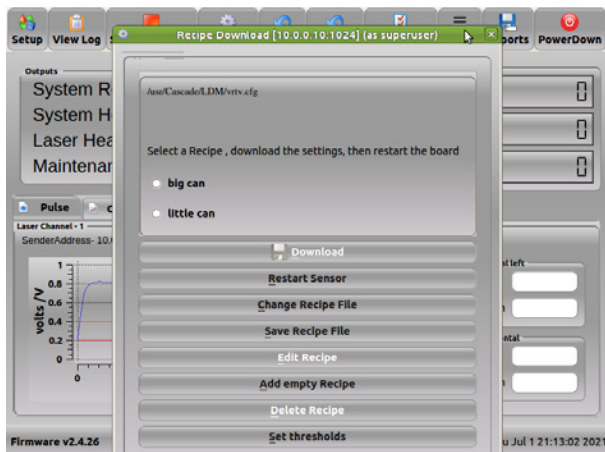

The upper and lower thresholds required can be entered. Pressing **Send Values** will update the system immediately. No software reboot is required.

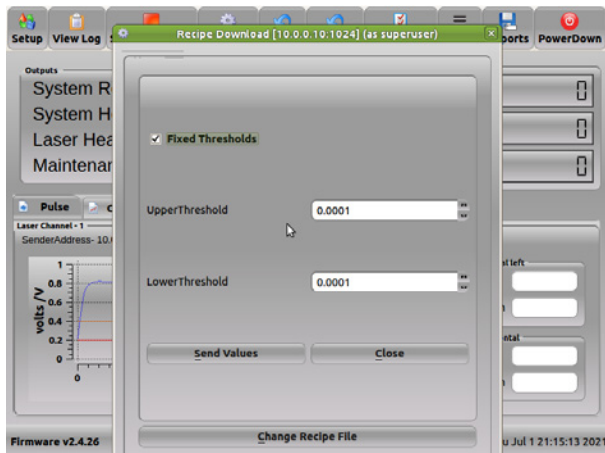

Note

Additional recipes can be added to the list. New recipes **can only** be added by an Emerson technician or under Emerson supervision .

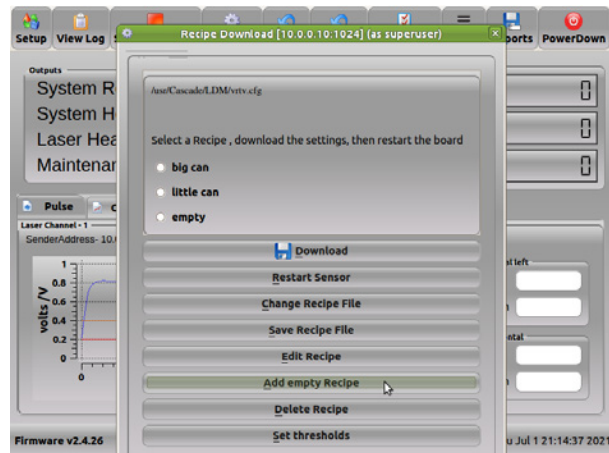

6.1.9 Power down

Select the power down button when shutting down the leak detector **before** switching off the main power supply.

Note

Switching off the mains power without powering down the software can cause data loss and/or corruption.

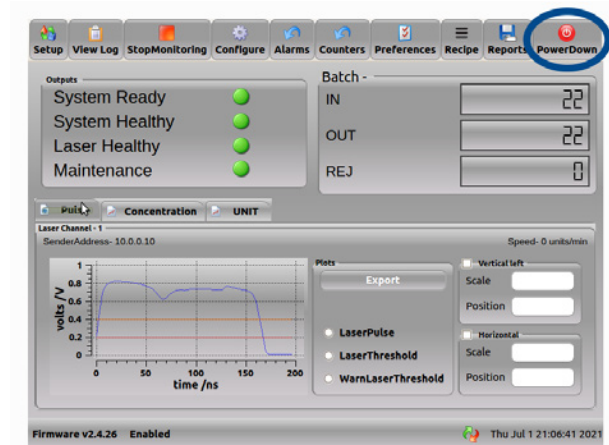

Confirm computer shutdown is required.

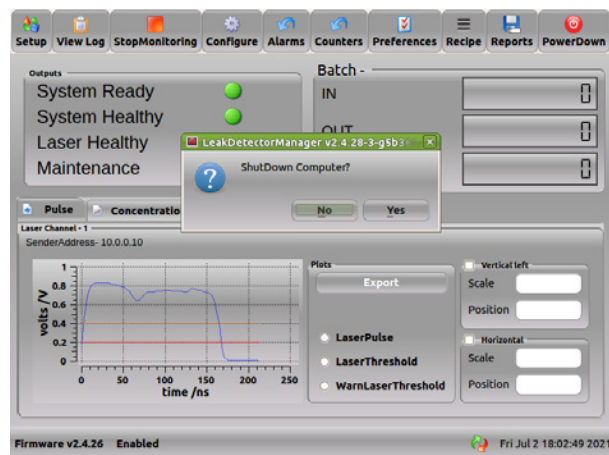

6.2 Data logging and reporting

The system can store production statistics, including number of packs processed and number of rejects detected. This can be transferred from the HMI display screen on a USB stick for analysis elsewhere.

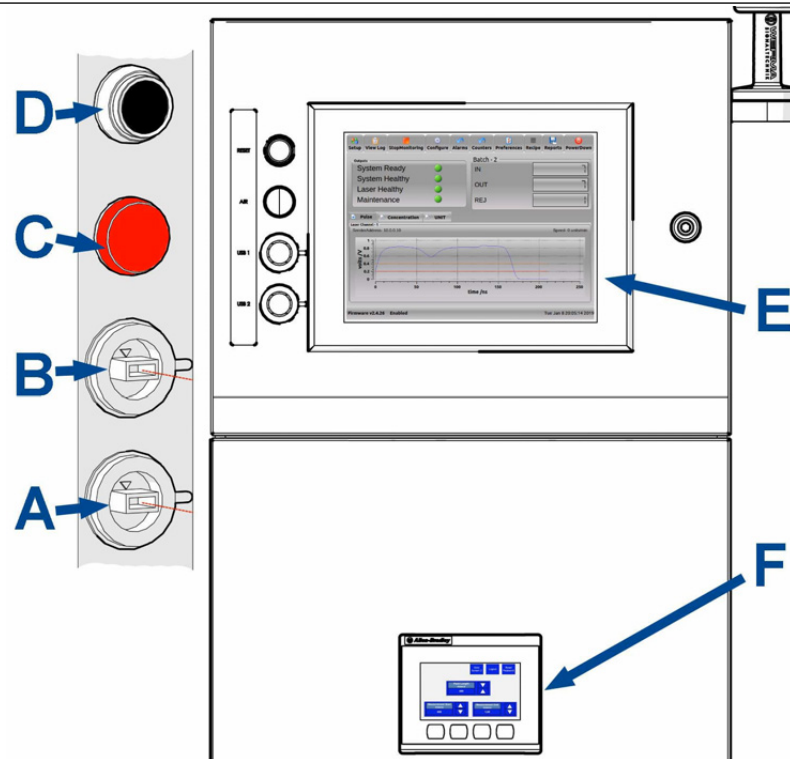

- A. USB port 2.
- B. USB port 1.
- C. Air fault indicator.
- D. Reset button.
- E. Main HMI display screen.
- F. PLC display screen.

Select **Reports** to start the reporting process. The reporting screen is password protected, the password will be supplied during installation. Follow the on screen instructions to generate the report required.

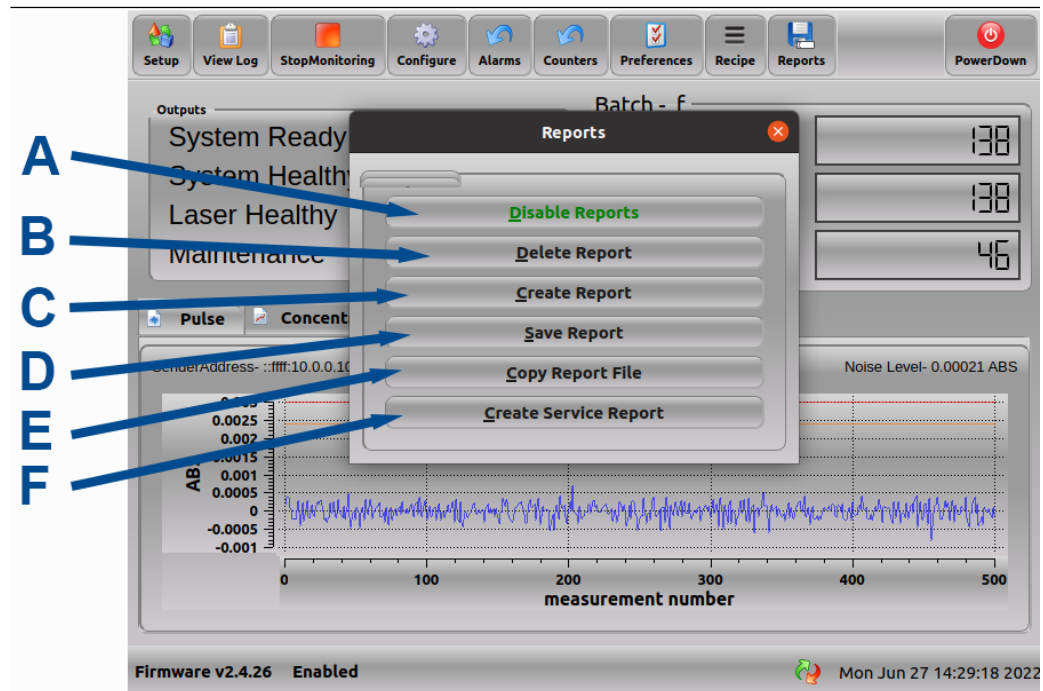

- A. **Enable/Disable Reports:** Turn reporting on or off.
- B. **Delete Report:** Delete a file from a specified location.
- C. **Create report:** Set the file name and save location.
- D. **Save Report:** Save the current file to a specified location.
- E. **Copy Report File:** Move a file from one location to another.
- F. **Create Service Report:** Creates a service report.

Note

The file must be saved as <filename>.txt

You can export the .txt report file to a USB stick and process it elsewhere. If you open the file using a spreadsheet application, it will look like the example below.

A	B	C	D	E	F	G	H
Log	file	opened	at	28.06.2017	09:10:19		
Client	name	ABC					
Product	name	Tasty ABC					
Batch	number	14					
Number	UNITS	Rejected	16				
Number	UNITS	Processed	729				
Log	file	closed	at	28.06.2017	09:39:57		
Date	Time	Leak(abs)	Leak(cal)	UT	LT	noiselevel	reject
28.06.2017	09:10:05	0.00136928	0	0.005	0.004	0.000534323	0
28.06.2017	09:10:09	0.000571722	0	0.005	0.004	0.000612099	0
28.06.2017	09:10:12	0.00140842	0	0.005	0.004	0.000612099	0
28.06.2017	09:10:14	0.000849349	0	0.005	0.004	0.000612099	0
28.06.2017	09:10:20	0.0119992	0	0.005	0.004	0.000651409	1
28.06.2017	09:10:23	0.00117535	0	0.005	0.004	0.000423098	0
28.06.2017	09:10:25	0.00119883	0	0.005	0.004	0.000423098	0
28.06.2017	09:10:27	0.0007473	0	0.005	0.004	0.000423098	0
28.06.2017	09:10:29	0.000668466	0	0.005	0.004	0.0003398	0
28.06.2017	09:10:31	0.00100697	0	0.005	0.004	0.0003398	0

Client/Product/ Batch These are entered during the creation of the log file.

Date/Time The time stamp for each unit; this is set by the PC.

Leak (abs) The maximum concentration value for each unit. If this value is greater than the upper threshold, this package will be rejected.

Leak (cal) For certain applications, a calibration factor may be applied in order to have units for leakage (i.e., bubbles/second or mg/day).

UT The upper threshold value. If the concentration exceeds this value, the package is rejected.

LT The lower threshold: If two consecutive concentration points exceed this value, the package is rejected.

Noiselevel The noise value at the time when the package is logged.

Reject Packages which do not breach thresholds are `reject = 0`, and those which breach thresholds are `reject =1`.

Note

If you want to view only rejected packages, then filter column **H** to show only rows with **1** in them.

NOTICE

The *CanInfo* type is logged for all units processed; the *Reject* type only shows the reject value.

6.3 Status lamps / errors

There are a number of errors that the leak detection system monitors. Errors are displayed as an illuminated lamp on the front or side of the enclosure, the alarm beacon or on the HMI display screen.

All errors latch and are cleared by the **RESET** button on the front of the enclosure. The errors are detailed below and, when activated they trigger the red beacon bulb, black buzzer and line stop (if applicable).

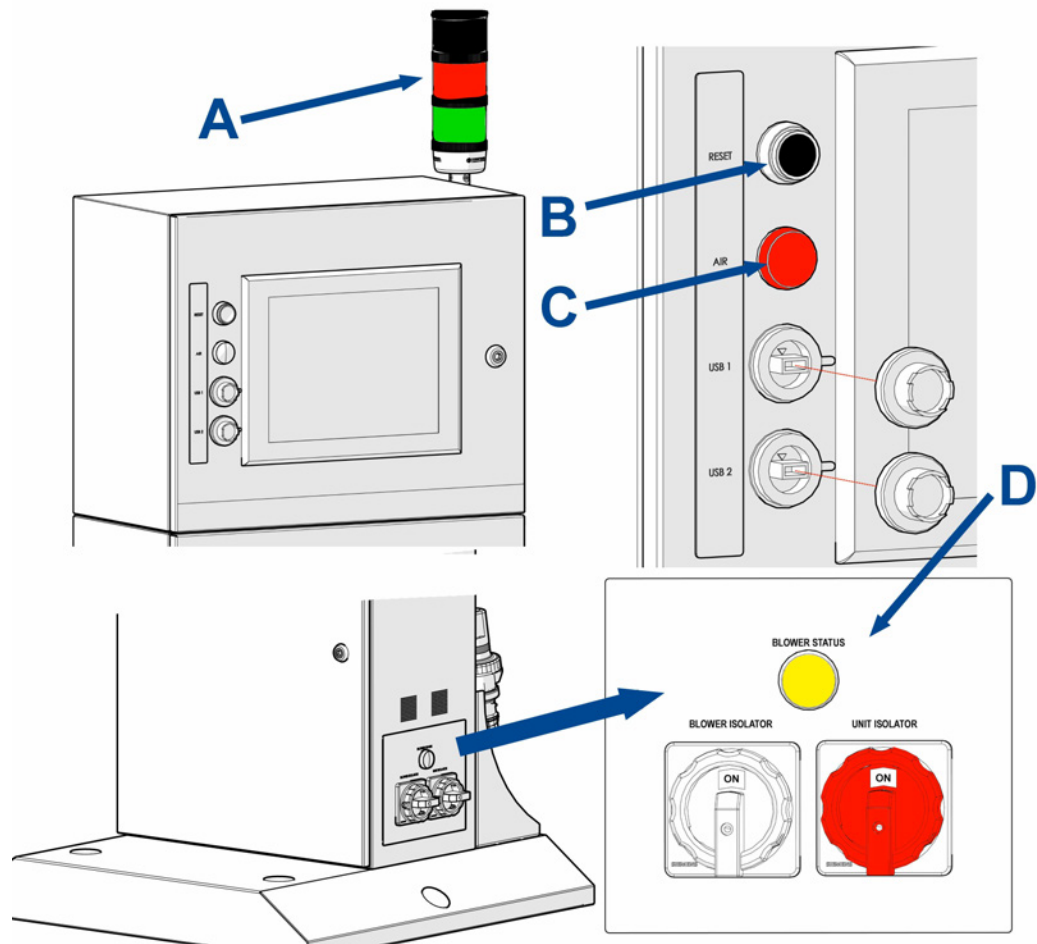

- A. **Alarm beacon:** Green for healthy; red for unhealthy/line stop, black audible buzzer for unhealthy/line stop.
- B. **Reset button** to clear latched alarms.
- C. **AIR status bulb.** Illuminates when blower or compressed air is off.
- D. **Blower status:** The bulb is on when power is supplied to the blower motor. If the power is interrupted, the bulb doesn't turn on, and the **AIR** status bulb on the enclosure door turns on.

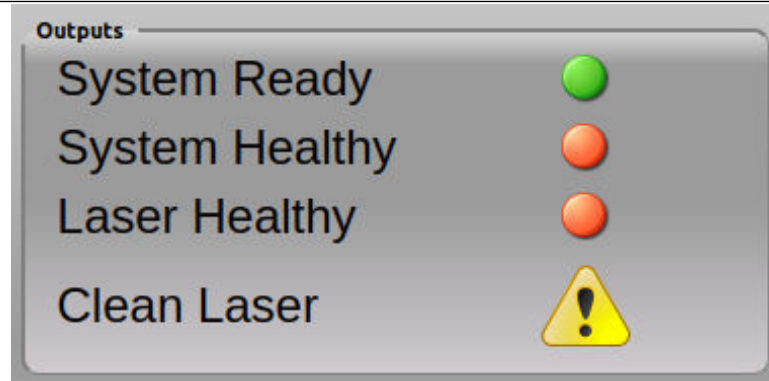

System Ready Shows when the system is ready for use. This is red during system start up.

System Healthy The system can become unhealthy if the gate in/out count is different or if there have been n consecutive rejects (the default value is five consecutive rejects). Press **Reset counters** on the HMI to clear the error.

Laser Healthy The laser becomes unhealthy if it is below the threshold value (see the red line in). Check the beam path for obstruction or clean the cell mirrors as described in . This error automatically clears when the pulse amplitude is above the threshold.

Maintenance: The yellow warning triangle appears if the laser pulse amplitude is below the warning threshold value. System performance is not affected, but you should consider activating the mirror purge or cleaning the cell mirrors soon. This error automatically clears when the pulse amplitude is above the warning threshold.

Too many Consecutive Rejects: If several packs are rejected in a row, this error is triggered. shows the error message generated. To reset this error, press the **Reset Alarms** button on the touch screen.

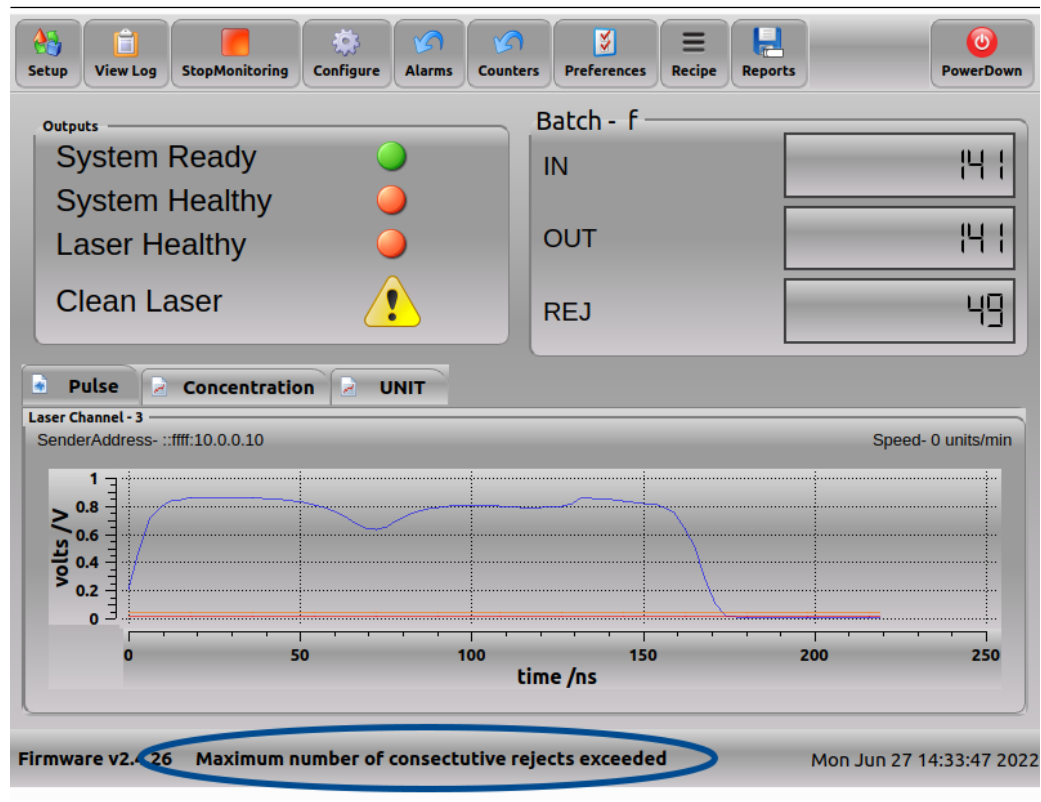

6.4 Status

The leak detector PLC control system provides a fault signal, allowing the customer to determine the action required.

The signal is provided by the normally open and normally closed contacts of a relay. The signal is sent to the STATUS connector shown in [Electrical, signal, compressed air in and sample gas connection details](#)

6.5 PLC configuration

The PLC settings directly control the analysis and rejection of defective product containers. The PLC screen has password protection in order to prevent unauthorized Only trained personnel should change the settings for the PLC. access. The credentials are provided to the relevant department during installation. Following any change to line speed, pack size, or pack spacing, qualified personnel should verify the system setup to ensure test packs are being detected correctly.

The system is designed to accommodate changes in pack size and line speed. There are five configurable parameters (A, B, E, F & H) highlighted in red in the following diagram.

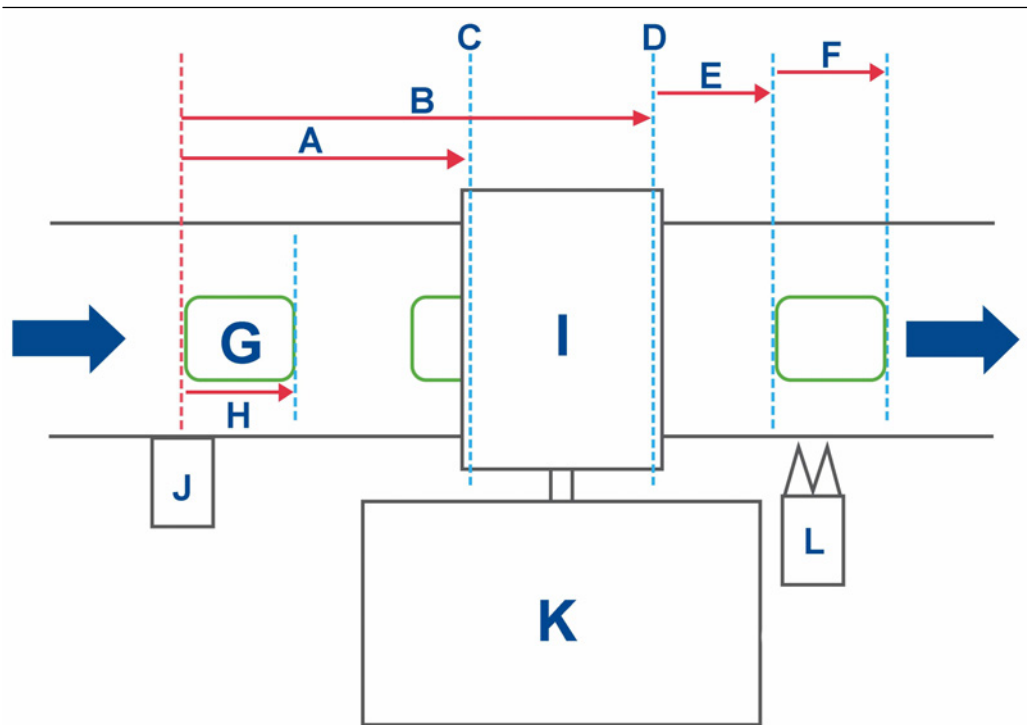

- A. Measurement start.
- B. Measurement finish.
- C. Sensor count in.
- D. Sensor count out.
- E. Reject delay.
- F. Reject duration.
- G. Single product pack (One Shot)
- H. Product pack length.
- I. Sample head.
- J. Input gate location.
- K. Leak detection control system.
- L. Reject mechanism location.

PLC Screen Options

Pack Length This is the length of the pack defined in msec (milliseconds). This method is used to prevent the input gate counting a pack twice. (e.g. for an uneven pack shape).

Range 0 - 2000 msec

Measurement Start This is the delay between the system input gate and the pack entering the sample head.

Range 0 - 9000 msec. (Start time = pack travel time between input gate first sample bar + time taken for gas sample to reach the leak detector)

Measurement End This is the delay between the system input gate and the pack exiting the sample head. This ensures the full pack length is inspected.

Range 0 - 10000 msec. (End time = time taken for the gas sample to reach the leak detector + pack travel time between first and second sample bars)

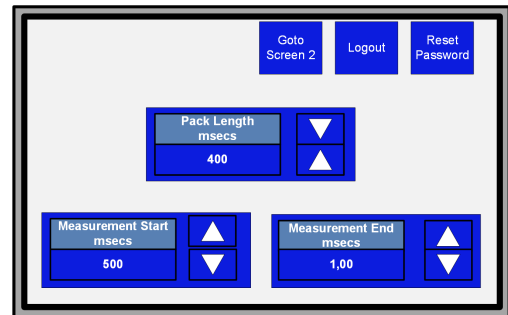

Reject Delay This is the delay between measurement end and the rejection point.

Range 0 - 60000 msec (1 minute)

Reject Duration The time the rejector will remain on for. This should be set long enough to ensure the pack is rejected but not long enough that the following pack is rejected in error.

Range 0 - 10000 msec

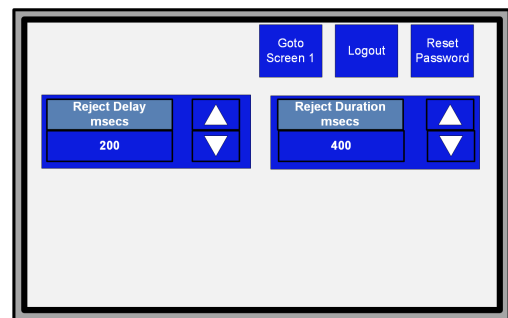

6.5.1 Setting the pack length

Procedure

1. The production line **MUST** be running steadily at the required production rate to ensure accurate measurements. If the line speed is changed the measurement will need to be repeated and reset.

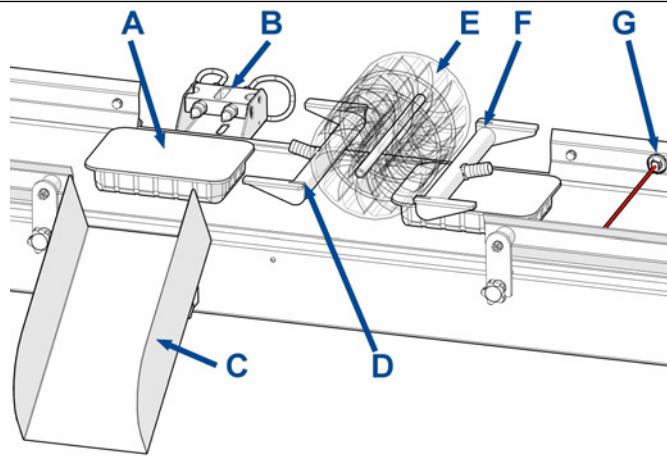

- A. Product pack.
- B. Reject mechanism.
- C. Reject chute / bin.
- D. Second sample measurement bar.
- E. Typical pack handling device.
- F. First sample measurement bar.
- G. Input gate.

2. Divide the production line speed in m/s (or ft/s) by the maximum pack length in m or (ft) to determine the time it would take for the pack to pass through the input gate in msec (milliseconds). One second = 1000 msec.

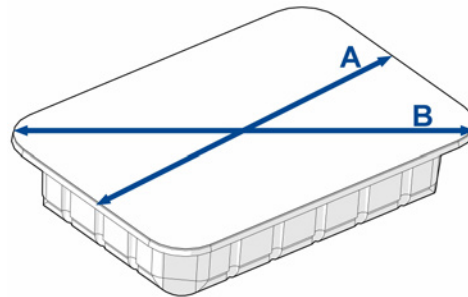

- A. Minimum pack length.
- B. Maximum pack length.

3. Alternatively, using a stopwatch or video determine the time taken for a pack to fully pass by the input gate. For fast moving product lines take the measurement over a larger number of packs and divide the time recorded by the number of packs

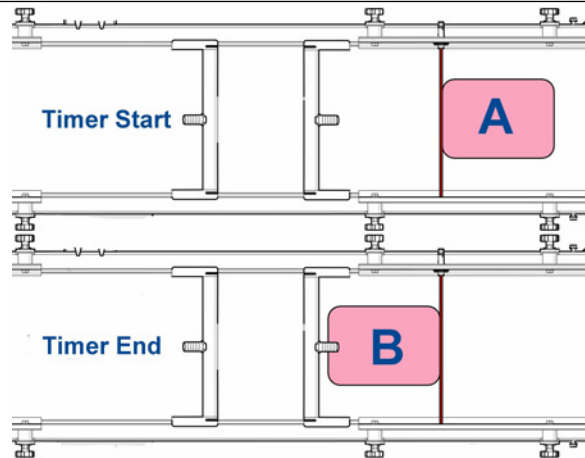

- A. Pack position when the timer starts.
- B. Pack position when the timer stops.

4. Repeat the measurement a number of times to ensure a consistent result.
5. Convert the time taken to msec (milliseconds). One second = 1000 msec.
6. Enter the calculated time taken in msec on the PLC screen to set the required Pack Length for the product being run.

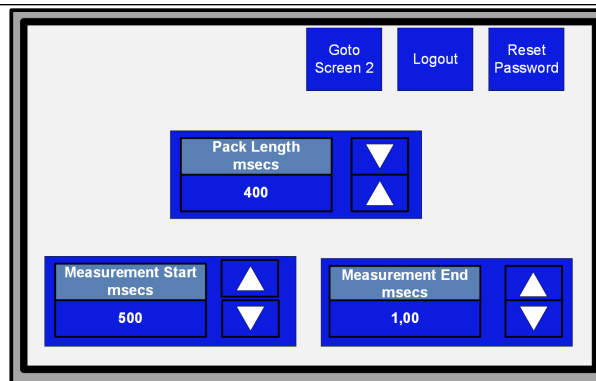

7. Run the production line and monitor to confirm the setup has been calculated / entered correctly. Adjust if required.

6.5.2 Setting the measurement start and end

The measurement start and end require more detailed configuration. Sufficient time **MUST** be taken to ensure that all steps in the procedure below have been completed.

Procedure

1. The production line **MUST** be running steadily at the required production rate to ensure accurate measurements. If the line speed is changed the measurement will need to be repeated and reset.

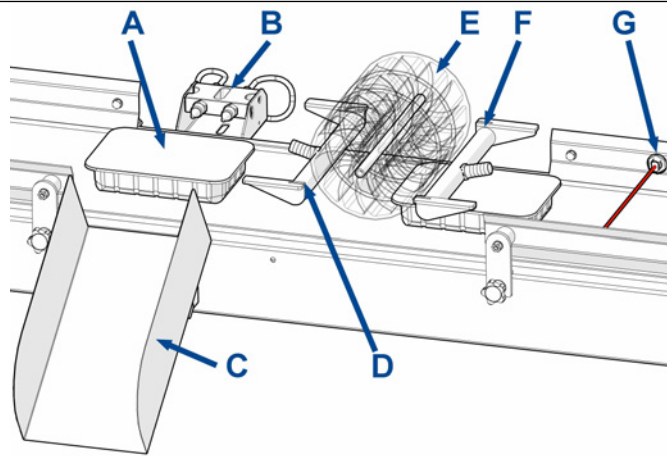

- A. Product pack.
- B. Reject mechanism.
- C. Reject chute / bin.
- D. Second sample measurement bar.
- E. Typical pack handling device.
- F. First sample measurement bar.
- G. Input gate.

2. Using a stopwatch or video determine the time taken for a pack to pass between the input gate and the first sample measurement bar. For fast moving product lines take the measurement over a larger sample number of packs and divide the time recorded by the number of packs.

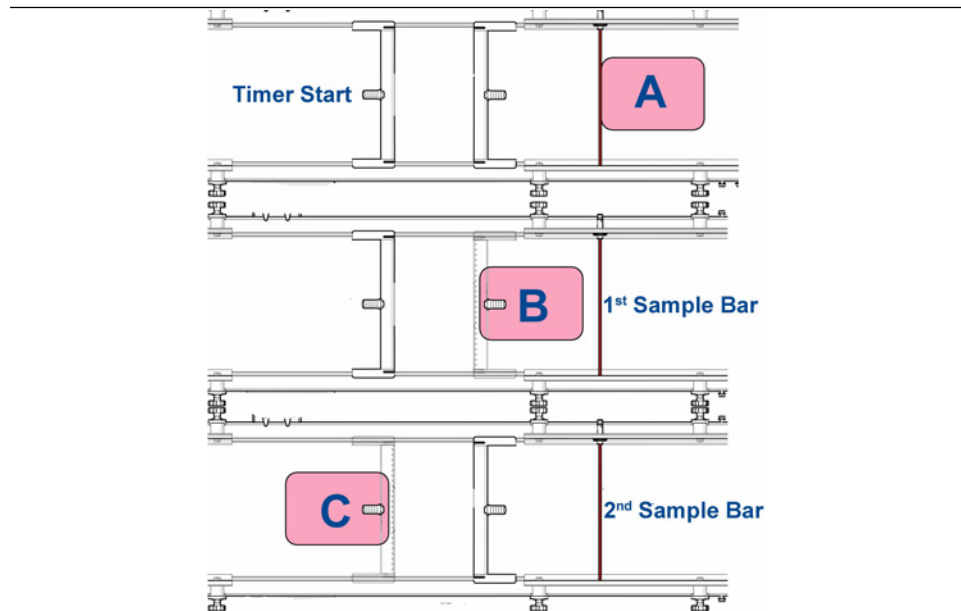

- A. Pack position when the timer starts.
- B. Pack position when the timer stops for the first sample measurement bar.
- C. Pack position when the timer stops for the second sample measurement bar.

3. Repeat the measurement a number of times to ensure consistent results.
4. Convert the time taken to msecs (milliseconds). One second = 1000 msecs.
5. Enter the time taken in msecs to set the required measurement start time.

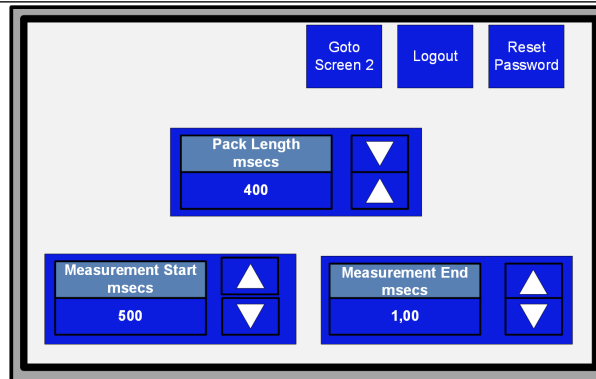

6. Repeat this process to measure the time taken for the pack to pass between the input gate and the second sample measurement bar. Add a further 500 msecs to the time taken and enter it as the initial measurement end time.
7. A test pack with a known leak situated at the far end of the pack will be sent along the product line to confirm the setup.
8. Leak detection is confirmed when a spike has been detected on the concentration screen as shown.

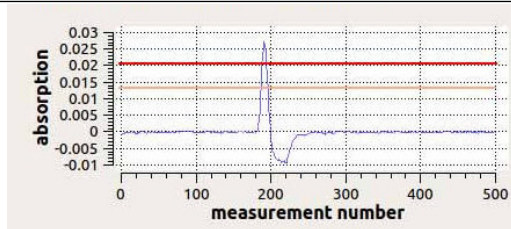

9. Select the tab marked **UNIT**. Confirm the location of the spike within the detection window. If a spike is not present, decrease the measurement start value by 100 msecs and increase the measurement end value by 100 msecs. (This adjustment is to account for the time taken for the sample to reach the analyzer in the leak detection unit.) Repeat the test until the spike is detected. **Always confirm the presence of a spike on the concentration screen before checking the unit tab.**

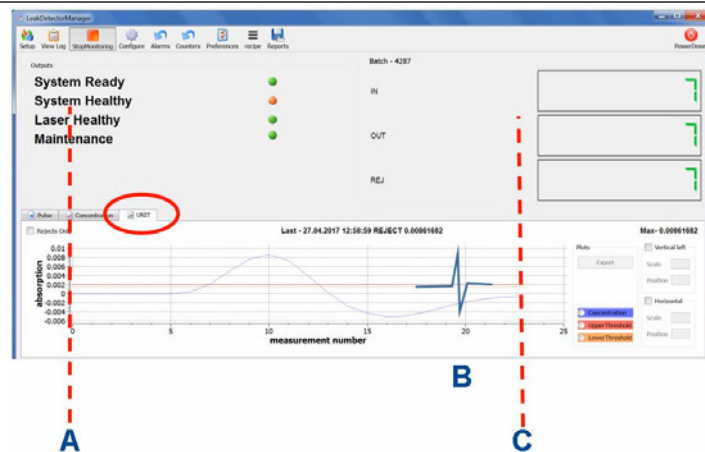

- A. Measurement start.
- B. Far end leak detected.
- C. Measurement end.

10. Retest a minimum of 10 times to confirm that the spikes are being detected for packs with a far end leak. Spikes will be detected consistently in the same region of the graph. **Always confirm the presence of a spike on the concentration screen before checking the unit tab**
11. Change the test pack being tested to a near end leaking pack to confirm the measurement start time.
12. Leak detection is confirmed when a spike has been detected on the concentration screen as shown.

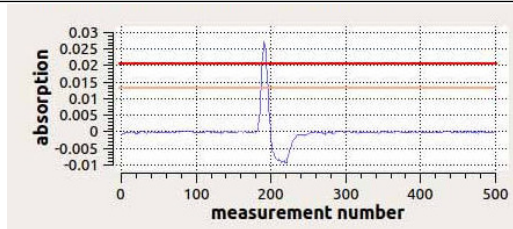

13. Select the tab marked **UNIT**. Confirm the location of the spike within the detection window. If a spike is not present, decrease the measurement start value by 10 msecs. Repeat the test until the spike is detected. **Always confirm the presence of a spike on the concentration screen before checking the unit tab.**

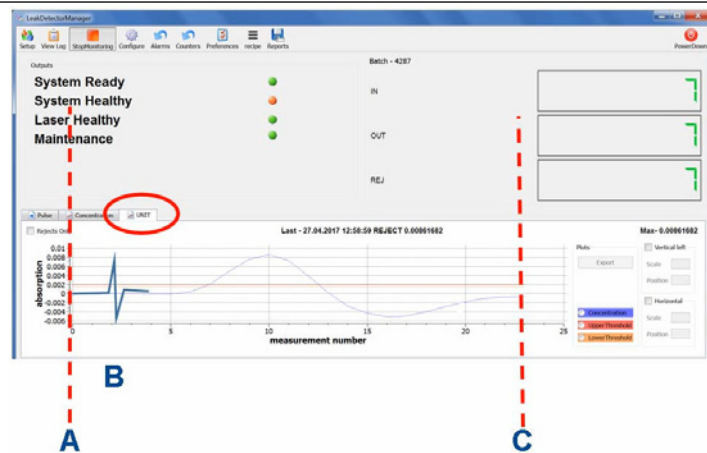

- A. Measurement start.
- B. Near end leak detected.
- C. Measurement end.

14. Retest a minimum of 10 times to confirm that the spikes are being detected for packs with a near end leak. Spikes will be detected consistently in the same region of the graph. **Always confirm the presence of a spike on the concentration screen before checking the unit tab**
15. The measurement window (measurement start – measurement end) is now set for this package type and product line speed.
16. If other package types and line speeds are used commonly then these should be configured separately. Record the settings for each pack and product line speed this will allow production runs for different pack sizes to be changed over quickly.
17. At the end of the above procedure leaks located anywhere on the pack length will appear on the unit tab, as shown.

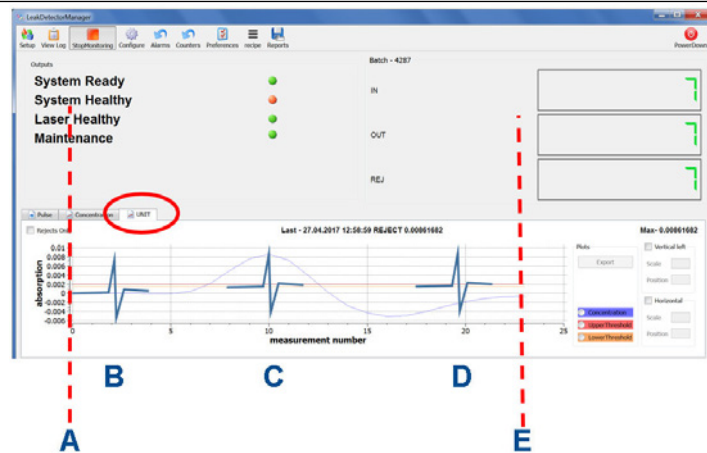

- A. Measurement start.
- B. Front leak detected.
- C. Middle leak detected.
- D. Back leak detected.
- E. Measurement end.

6.5.3 Setting the reject delay / duration

The reject delay/duration is configured after the measurement start / stop has been configured. window and ideally the reject mechanism should not be installed until this is done.

Procedure

1. The production line **MUST** be running steadily at the required production rate to ensure accurate measurements. If the line speed is changed the measurement will need to be repeated and reset.
2. Sample packs with a known leak will be required to trigger the reject mechanism.
3. Once the pack length and measurement start / stop settings have been configured set the initial reject delay to 10 msecs (milliseconds).
4. Set the reject duration msecs to the time obtained in [Setting the pack length](#).

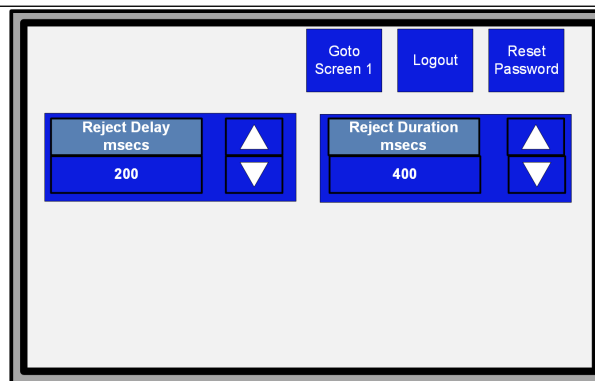

- Send through a leaking pack and confirm where on track it is positioned when the reject mechanism would fire. This is the minimum distance away that the rejection system must be installed.

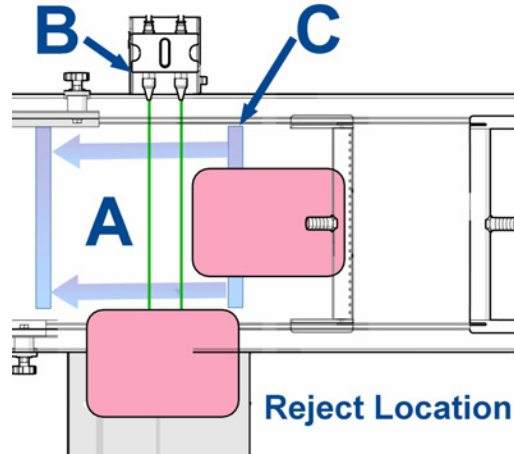

- Reject area
- Reject mechanism.
- Minimum reject location distance.

- Confirm with customer where the reject mechanism is to be installed on the production line and mark the position with tape.
- Using a stopwatch or video determine the time taken for the leading edge of the pack to reach the tape mark. For fast moving product lines take the measurement over a larger sample number of packs and divide the time recorded by the number of packs.
- Repeat the measurement a number of times to ensure consistent results.
- Convert the time taken to msec (milliseconds). One second = 1000 msec.
- Reset the reject delay time to the time taken in msec to reach the tape mark.



- Install the reject mechanism at the tape mark.
- Retest a minimum of 10 times to confirm that the packs are being rejected cleanly. If required, adjust the reject delay in 50 msec steps to fine tune the operation.

13. If the reject mechanism is still operating after the pack has been rejected. Reduce the reject duration 10 msecs at a time.
14. Retest a minimum of 10 times to confirm that the packs are still being rejected cleanly.

7 Maintaining the leak detector

There is no need for a customer to access components not covered in this document. For further assistance contact your local Emerson distribution partner for support.

7.1 Scheduled maintenance

The leak detection system is designed to run unattended.

- Daily** Visually inspect the leak detector, cabling, pipework and sample head where fitted for signs of damage.
Visually check the HMI display for any system alerts logged.
Confirm the enclosure doors are shut and locked
- Weekly** Including the daily checks
Complete the [Shut down procedure](#) before cleaning down the outside of the leak detector with a soft damp cloth. **Under no circumstance use any other cleaning materials or methods on the outside of the unit.**
Visually inspect the sample gas inlet filter, only if required clean or replace.
- As Required** Cleaning the cell mirrors.
Purging the analysis cell.

7.2 Purging the analysis cell

⚠ WARNING

HIGH PRESSURE AIR

Serious injury or death could occur.

The compressed air supply operate at pressures that can cause injury.

Cell mirrors are a precision optical device essential to the continued accurate operation of the leak detector. Cleaning the mirrors should only be done if purging the cell mirrors does not return the system laser pulse to normal operating levels, due to the increased risk to them being damaged. Purging the system to blast compressed air into analysis cell to drive out dust or debris is the option that should be tried first.

Using an 8mm AF hex allen key give a quarter turn to open the top enclosure door lock. **Under no circumstance should the lower enclosure door be opened at this time as mains power is connected.**

Note

Cables are connected to the inside of the door. Care must be taken when opening and closing the door to prevent damage.

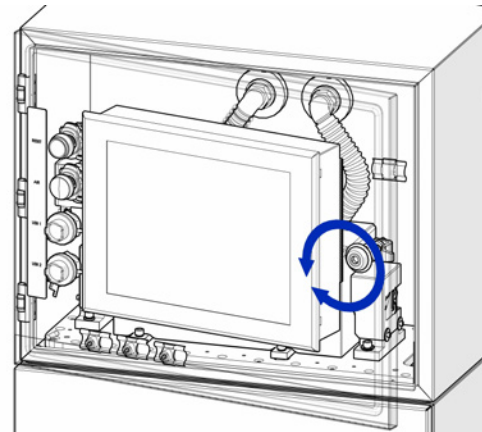

With the door open the purge button can be accessed. Press the button two or three times for a couple of seconds each to blast dry filtered compressed air into the analysis cell. Close and lock the door.

Note

If this does not solve the issue. Follow all the steps in [Cleaning the cell mirrors](#).

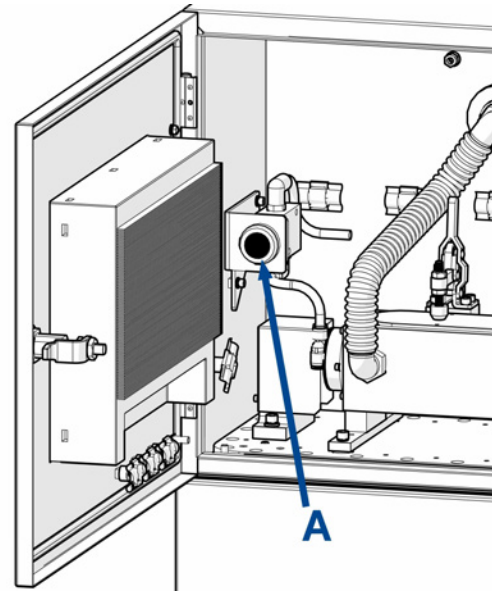

7.3 Cleaning the cell mirrors

⚠ CAUTION

LASER / OPTICAL PATH

Serious injury or death could occur.

Operators do not have access to the internal laser or electrics during normal operation.

Maintenance personnel must only access the internal laser or electrics after the analyzer has been turned off.

Opening the leak detection system and attempting to perform adjustments other than those specified in this manual may result in Class 3R optical radiation exposure. Do not look at the laser with any kind of magnifier or optical measuring device.

Cell mirrors are precision optical device essential to the continued accurate operation of the leak detector. Cleaning the mirrors should only be done if purging the cell mirrors does not the return system laser pulse to normal operating levels, due to the increased risk to them being damaged during this operation.

Mirrors should only be cleaned by trained, competent people using only the cleaning parts listed below:

- Optical grade lens cleaning tissues.
- Spectroscopic grade methanol or ethanol.

Preparation

Switch off the blower isolator.

Note

Leave the Unit Isolator switched on.

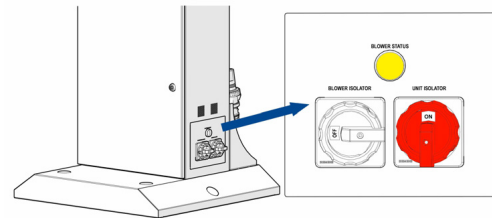

Using a 8mm AF hex allen key give a quarter turn to open the top enclosure door lock.

Under no circumstance should the lower enclosure door be opened at this time.

Note

Cables are connected to the inside of the door. Care must be taken when opening and closing the door to prevent damage.

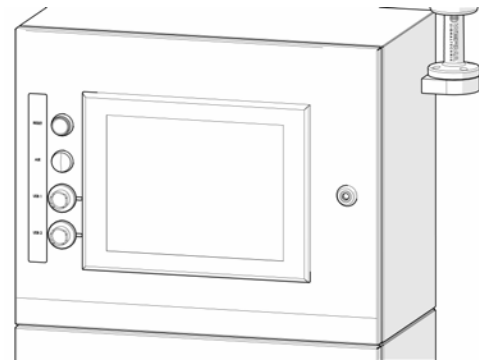

With the door open the analysis cell can be accessed.

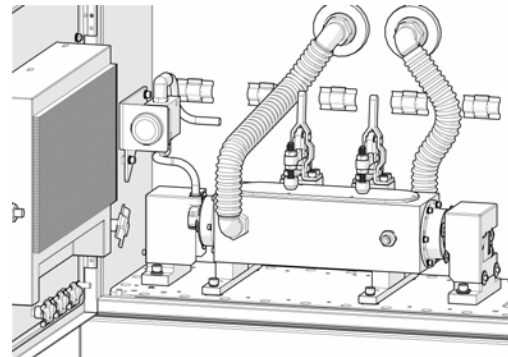

Preparation

Lift the clamp handles to release and open the toggle clamps.

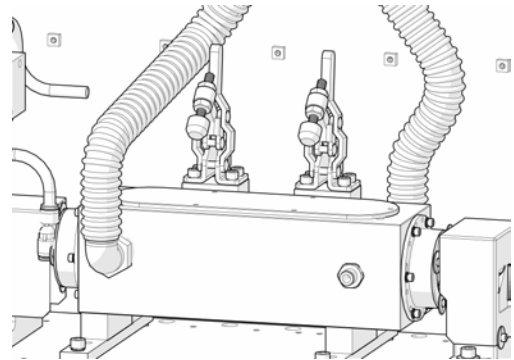

Remove the cell lid taking care not to damage the o-ring.

- A** Cell lid
- B** O-ring

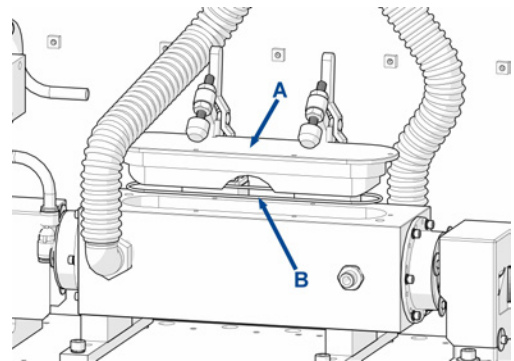

The two cell mirrors can be seen at opposite ends of the analysis cell as shown.

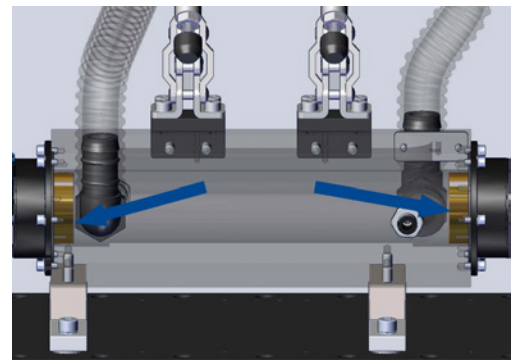

The cell mirror is recessed back into the ends of the analysis cell, making it difficult to see when cleaning.

Note

The cell mirror coating is delicate and highly reflective. Excessive force **WILL** permanently damage the mirror coating putting the leak detector out of operation.

ONLY trained operators should perform this task.

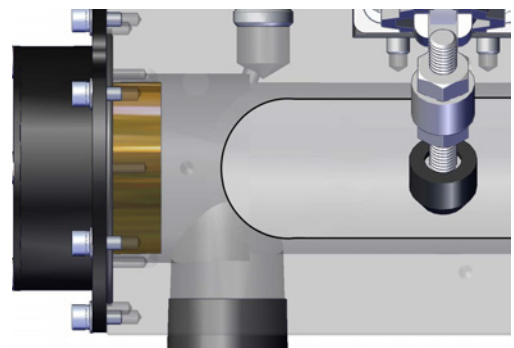

Mirror cleaning

Hands **MUST** be cleaned thoroughly before starting. If in doubt wear disposable gloves.
Fold a piece of lens tissue several times to produce an open soft loop of tissue as shown in method A or as a strip in method B.
Apply one or two drops of spectroscopic grade methanol or ethanol fluid to the front of the tissue as indicated by the arrow.

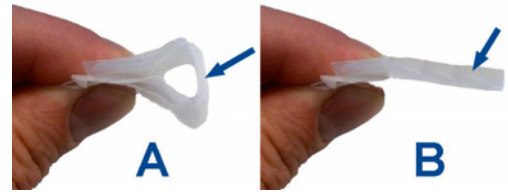

Do not apply any direct pressure compressing the tissue this will scratch the mirrors.



Wipe the wet tissue across the mirror in one continuous motion in the direction shown. **DO NOT apply pressure or repeat the process.**
The tissue should pass lightly over the mirror surface picking up any debris.

Note

Use 1 lens tissue for each mirror cleaned.

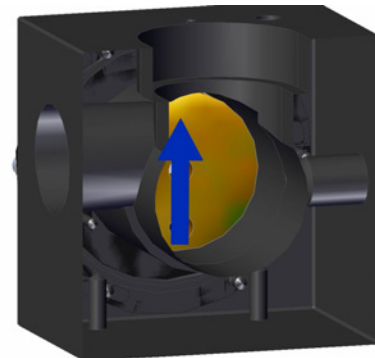

Mirror Cleaning Complete

Carefully refit the o-ring and cell lid to the analysis cell.

- A Cell lid
- B O-ring

Using the toggle clamps lock the cell lid in place.

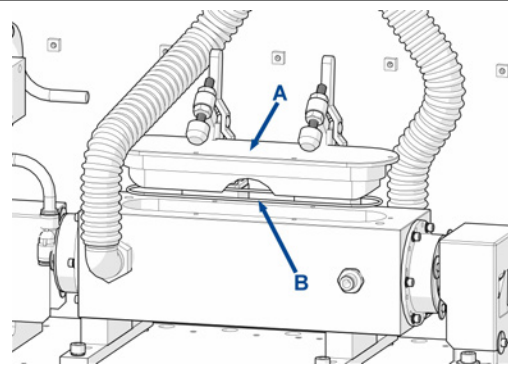

Mirror Cleaning Complete

Close and lock the top enclosure door using the hex allen key.

Note

Cables are connected to the inside of the door. Care must be taken when closing the door to prevent damage.

Follow the [Start-up procedure](#) to restart the leak detection system.

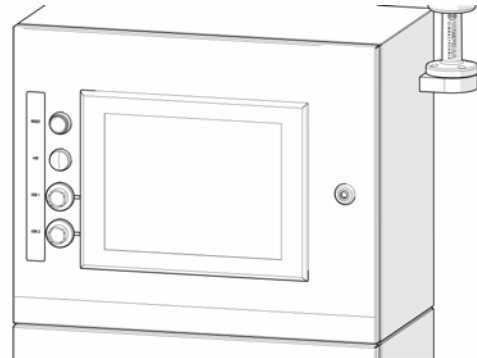

Reset any **Alarms** indicated on the display panel. Check the pulse amplitude on the display to ensure it is > 0.4 V.

Note

Contact cascade.support@emerson.com if there are any issues.

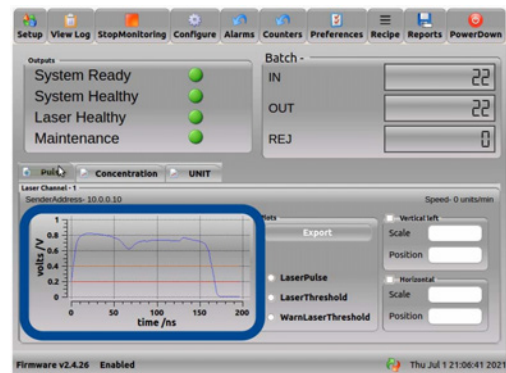

7.4 Replace the sample gas inlet filter

The sample gas filter is essential as it prevents dust and debris from reaching the analysis cell.

Switch of the blower isolator to stop the sample gas being drawn from the production line sample head.

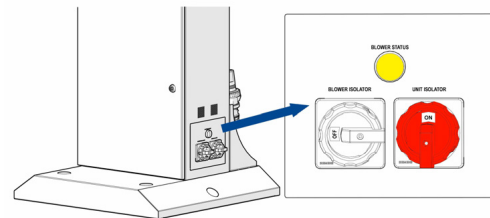

Locate the sample gas inlet filter connected to the rear panel.

- A Circlip retaining washer.
- B Filter housing
- C Replaceable filter module.
- D Sample gas inlet connection

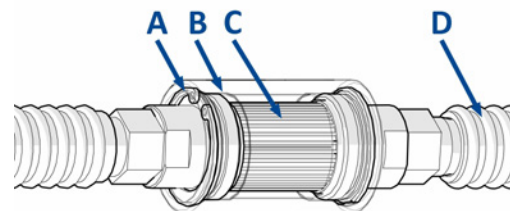

Carefully remove the retaining circlip washer.

Note

To prevent damage or injury use the correct circlip pliers for this task.

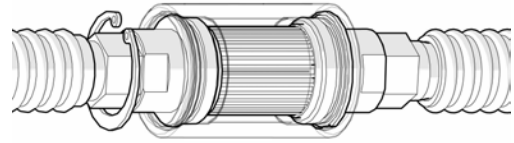

Remove the filter housing inlet connection, taking care not to damage the o-ring fitted at position A.

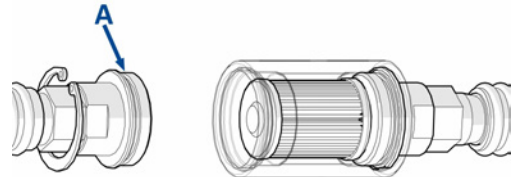

The replaceable filter element can now be changed or cleaned using an appropriate air line with clean dry filtered air.

Note

Filter replacement elements **MUST** be obtained from cascade.support@emerson.com or Emerson distribution partners to ensure the leak detector performance is not compromised.

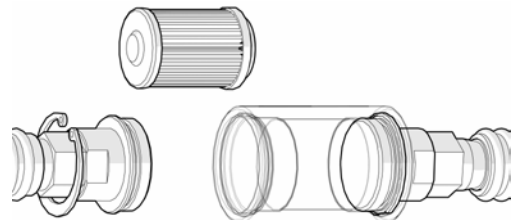

7.5 Replacing a fuse

Fuses are located on the electrical backplate located in the lower enclosure. **Due to the risk, only a competent person can perform this task.**

⚠ DANGER

ELECTRIC SHOCK

Serious injury or death will occur.

The leak detection system operates using mains voltage and must be switched off and the power cable removed before opening the analyzer.

Turn off the compressed air supply connected to the leak detector.

On the main display screen, select the **PowerDown** option indicated.

The onboard software will now start the shutdown process.

After a short delay the main display screen will switch off.



Switch off the blower and unit isolators.

Note

This is essential to ensure the unit is off before the lower enclosure door is opened.

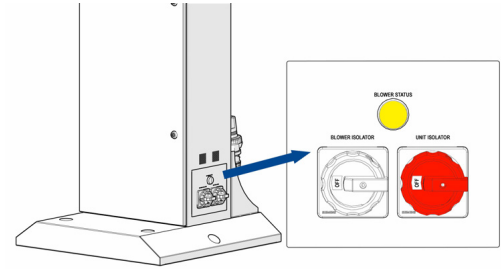

Only a competent person can open the
Using an 8mm AF hex allen key give a quarter
turn to open the lower enclosure door locks.

Note

Cables are connected to the inside of the door.
Care must be taken when opening and closing
the door to prevent damage.

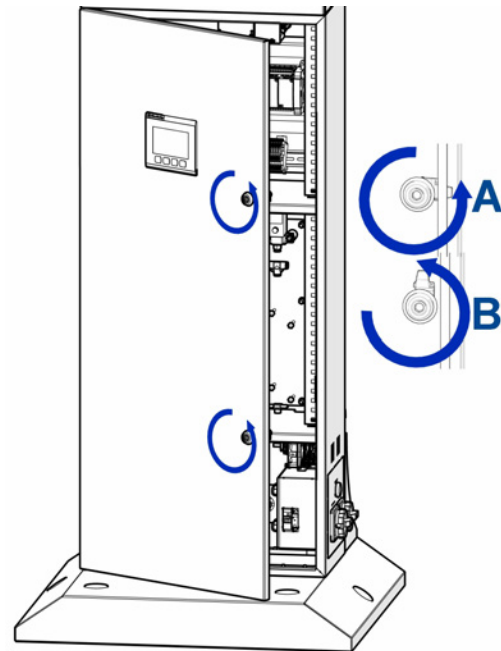

The fuses are located on the lower DIN rail fitted
to the electrical back plate.

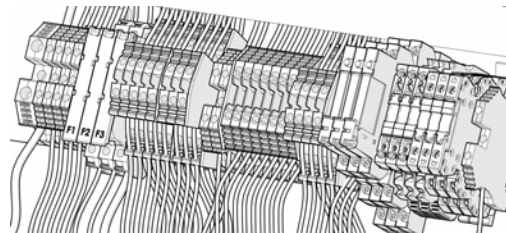

Locate the fuse required to be changed.

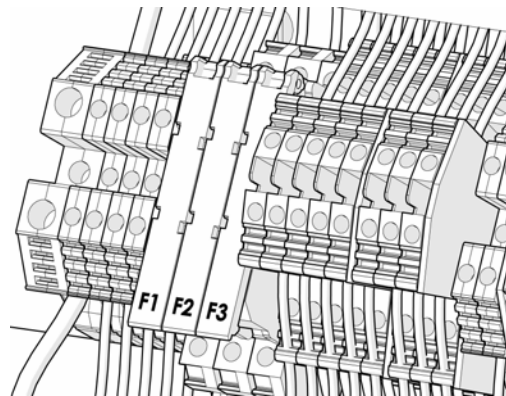

Using an ohmmeter confirm the circuit is off before proceeding.
Carefully open the hinged fuse cover as shown.

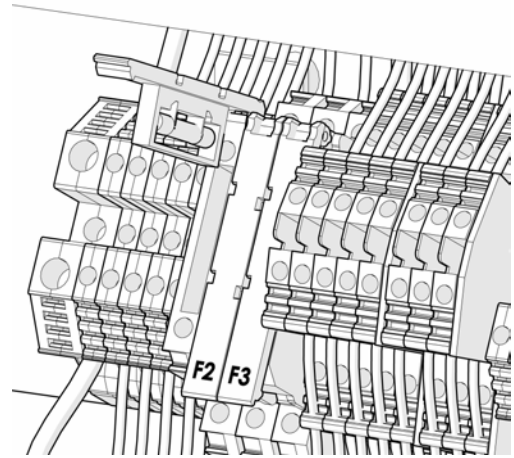

Remove the fuse and test using an ohmmeter.
If blown, replace the fuse.
If okay, refit and go to the [Troubleshooting and diagnostics](#) section.

Note

Only an approved fuse as specified below **MUST** be used.

- F1** 4 A (Eaton GMA-4-R)
- F2** 5 A (Eaton GMA-5-R)
- F3** 1 A (Eaton GMA-1-R)

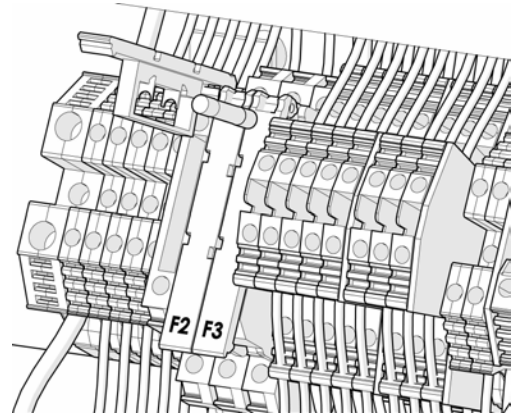

8 Troubleshooting and diagnostics

The leak detection system is designed to run unattended and to recover from system issues where possible. This section is designed to assist in the identification and solution of potential problems. If in doubt, contact cascade.support@emerson.com.

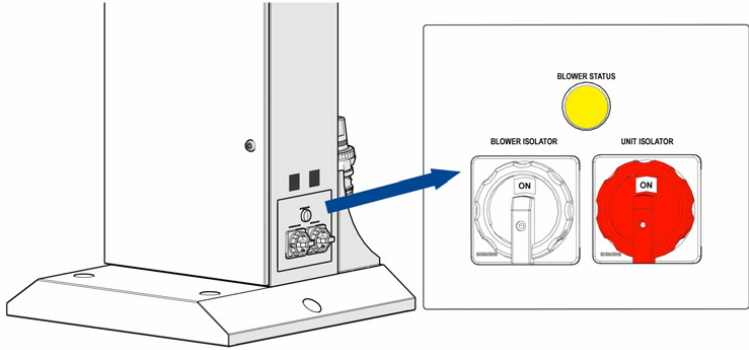
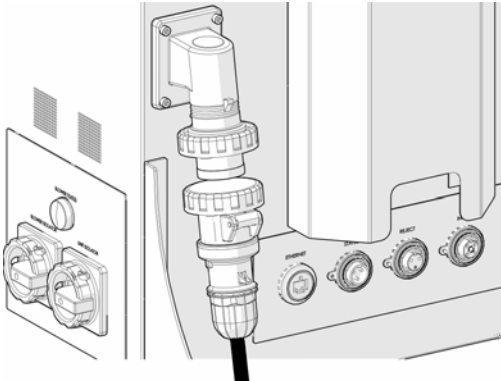
Fault symptom	Order of troubleshooting	Action or item to be replaced
HMI Display Screen not switching on.	Check the unit is switched on at the unit isolator. 	If Off switch On the isolator.
	Check the mains power plug is fully connected on the unit rear panel. 	<ul style="list-style-type: none"> • If loose or disconnected. • Switch off the unit isolator. • Fit the plug correctly and lock in place using the locking ring fitted. • Switch back on the unit isolator.
	Check the mains power cable connection to the customer circuit breaker or wall socket.	If Off switch On.
	Check the mains power cable connection to the customer circuit breaker or wall socket.	<ul style="list-style-type: none"> • If the circuit breaker has tripped. • Switch off the unit isolator and contact maintenance to investigate why it has tripped.

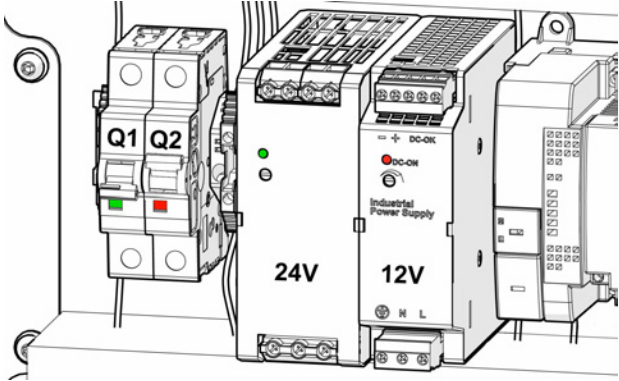
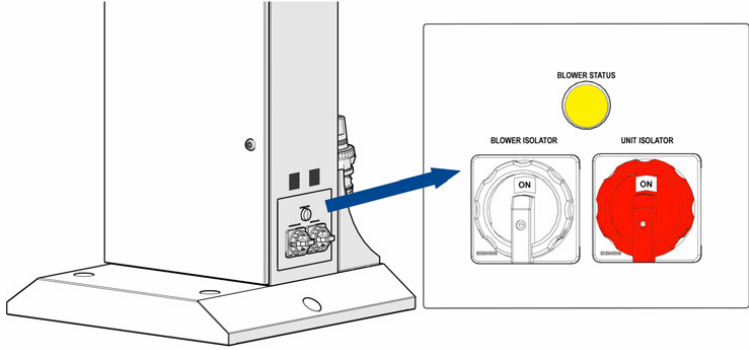
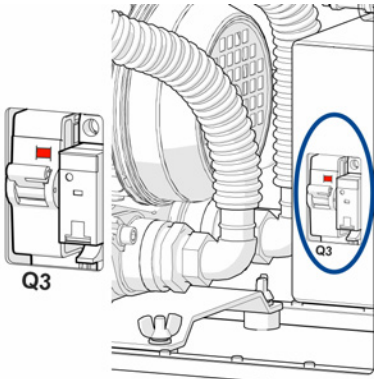
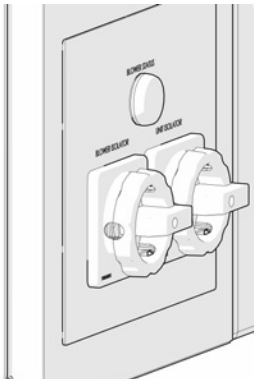
Fault symptom	Order of troubleshooting	Action or item to be replaced
	<p>Check the 12 and 24V Mini Circuit Breakers Q1/Q2 have not tripped.</p> 	<p>Reset if tripped.</p>
<p>Blower Motor is not switching on.</p>	<p>Check the unit is switched on at the Blower isolator fitted on the lower side panel.</p> 	<p>If Off switch On the isolator.</p>
	<p>Check the MCB fitted to the isolator distribution box has not tripped.</p> 	<ul style="list-style-type: none"> • Open the lower enclosure door. • If the circuit breaker has tripped. Switch off the blower isolator and contact maintenance to investigate why it has tripped. 

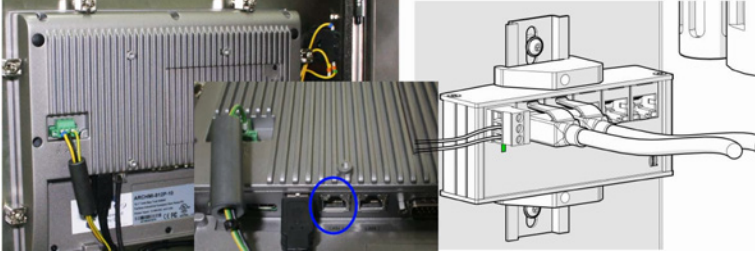
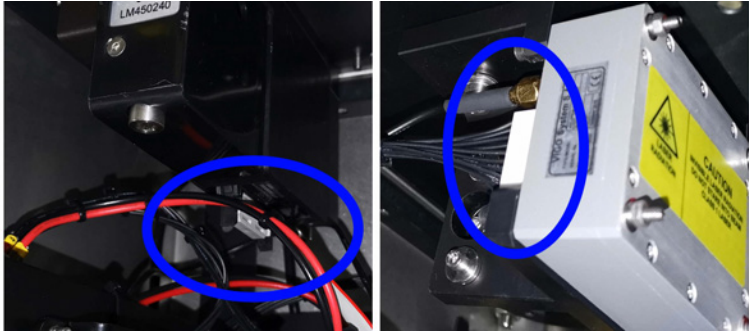
Fault symptom	Order of troubleshooting	Action or item to be replaced
<p>Laser pulse is not displayed or the concentration graph is not up dating.</p>	<p>Check network switch hub for a flashing LED.</p> 	<p>N/A</p>
	<p>Check UDP addresses match in <i>Configuration</i> screen and <i>Setup</i> screen.</p>	<p>Default values for the UDP addresses are 65501 and 65502.</p>
	<p>Check the laser and photodetector ribbon cables and SMA cable connections.</p> 	<p>Note The system must be switched off to prevent damage to lasers or photodetector during connection.</p> <ul style="list-style-type: none"> • Reconnect the cable connections if loose. • Trace the cables back to confirm the second end is also connected fully. • Restart the leak detector.
<p>Maintenance alarm on LDM.</p>	<p>If the pulse is below the LASER warning threshold, consider purging the cell with compressed air.</p> <p>Note The system will still be healthy.</p>	<p>Purge the cell.</p>
	<p>Consider cleaning the cell mirrors soon when pulse is below threshold.</p>	<p>Clean the mirrors.</p>
<p>Laser unhealthy.</p>	<p>If the pulse is below the laser threshold, clean the cell mirrors.</p>	<p>Clean the mirrors.</p>
	<p>Check the laser beam path for obstructions.</p>	<p>Clear any obstructions from the laser beam path.</p>

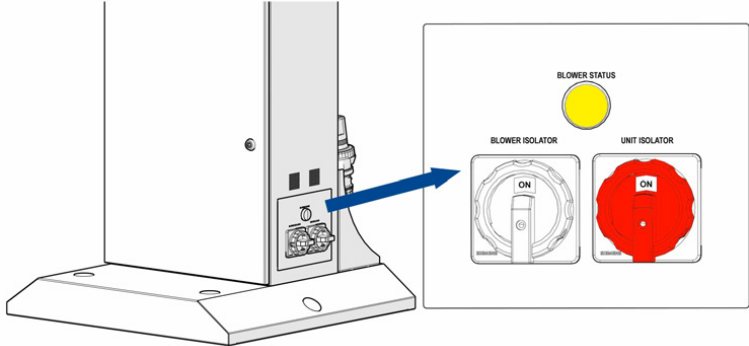
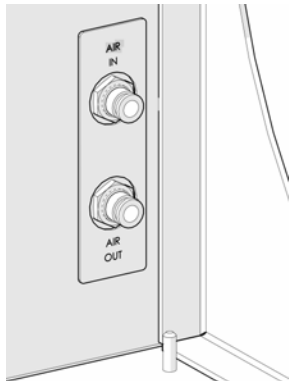
Fault symptom	Order of troubleshooting	Action or item to be replaced
System unhealthy.	If the pulse is below the laser threshold, clean the cell mirrors.	Clean the mirrors.
	Check the laser beam path for obstructions.	Clear any obstructions from the laser beam path.
	If the system has rejected n consecutive rejects, press the Reset alarms button on LDM.	Press the Reset button (see Status lamps / errors).
	If the IN/OUT count does not match, reset the counters.	Reset the counters.
AIR warning light illuminated.	Check the blower isolator is in the ON position and the blower status bulb is illuminated.	Switch the blower isolator ON.
	<p>Check the compressed air supply.</p> <ul style="list-style-type: none"> • Locate and turn off the customer air supply to the leak detector. • Examine the connections at the leak detector and the customer supply to ensure they are not damaged. • Check the air line is not pinched or kinked stopping air flow. • Turn back on the customer air supply. 	 

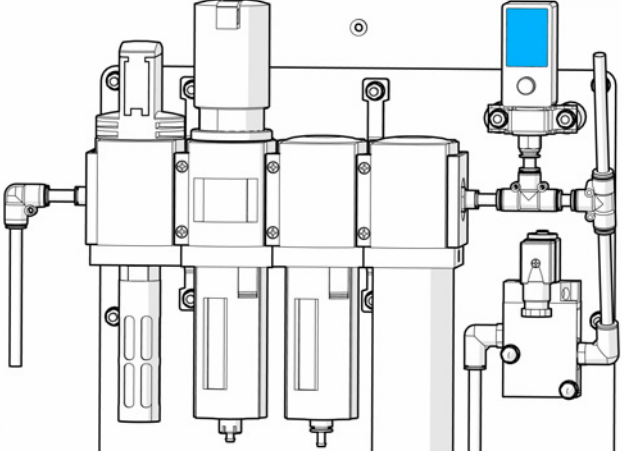
Fault symptom	Order of troubleshooting	Action or item to be replaced
	<p>Check air pressure supply is within the specified range for the pressure switch.</p>	<p>The pressure switch should be green confirming the supply pressure is set between 0.3 - 0.5 MPa. Adjust the pressure regulator if required.</p> 
<p>Traffic light is red and does not reset to green when the Reset button is pressed.</p>	<p>Check if the LDM dashboard is green.</p>	<p>Repeat the rows Laser unhealthy and System unhealthy above.</p>
	<p>Check if the AIR warning light is illuminated.</p>	<p>Repeat the row AIR warning light illuminated above.</p>
<p>System is not counting packs.</p>	<p>Check the INPUT gate cable is attached at both ends: control system and light gate.</p>	<p>Attach the cable (do not hot plug if loose).</p>
	<p>Check that the orange LED is flashing on the light gate when a pack enters the system.</p>	<p>Gate sensitivity can be adjusted using the dial on the light gate. It should flash orange when the beam is broken at a distance of approximately 20 to 200 mm.</p>

A Specification

Item	Measurement	Notes
Dimensions and Weights		
As Installed Dimensions	799 x 703 x 1907 mm (31.5 x 27.7 x 75.1 inch)	Depth x width x height (top of beacon)
As Installed Weight	119 kg (263 lb.)	N/A
Dimensions with transportation wheels	849 x 1010 x 1939 mm (33.4 x 39.8 x 76.4 inch)	Depth x width x height (top of beacon)
Weight with transportation wheels	TBA kg (TBA lb.)	N/A
Shipping container dimensions	925 x 1250 x 2000 mm (36.4 x 49.2 x 78.7 inch)	Depth x width x height
Gross weight including shipping container weight	160 kg (353 lb.)	N/A
Environment - for indoor use only		
Operating temperature range	-5 to 30 °C (23 to 86 °F)	Ambient installed operating temperature
Storage temperature range	-20 to 50 °C (-4 to 122 °F)	Ambient temperature when in storage / shipping.
Altitude	2000 m 6562 ft	N/A
Humidity range	10 to 95%	Relative humidity (non-condensing) at 35 °C (95 °F)
Ambient pollution degree	2	N/A
Laser Type		
Product laser classification	Class 1	BS EN 60825-1: 2014 safety of laser products. Equipment classification and requirements (IEC 60825-1 2014)
Production line services required		
System operating voltage	230 Vac ±10%, 60 Hz	Specify on order
	110 Vac ±10%, 50 Hz	
Overvoltage category	II	N/A
Maximum system power consumption	600 W	N/A
Factory compressed air supply	8 to 10 Bar 116 psi to 145 psi	Must be clean, dry, and oil free.
Factory compressed air filter.	0.1 µm	Inline filter
Sample line filter	5 µm	Inline filter

For more information: [Emerson.com](https://www.emerson.com)

©2022 Emerson. All rights reserved.

Emerson Terms and Conditions of Sale are available upon request. The Emerson logo is a trademark and service mark of Emerson Electric Co. Rosemount is a mark of one of the Emerson family of companies. All other marks are the property of their respective owners.

ROSEMOUNT™

